

THIS DOCUMENT CONTAINS PROPRIETARY INFORMATION WHICH IS THE PROPERTY OF QSC AUDIO PRODUCTS, THAT MAY NOT BE DISCLOSED, REPRODUCED OR USED WITHOUT EXPRESS WRITTEN CONSENT FROM QSC AUDIO PRODUCTS.

OP-AMP SUPPLIES

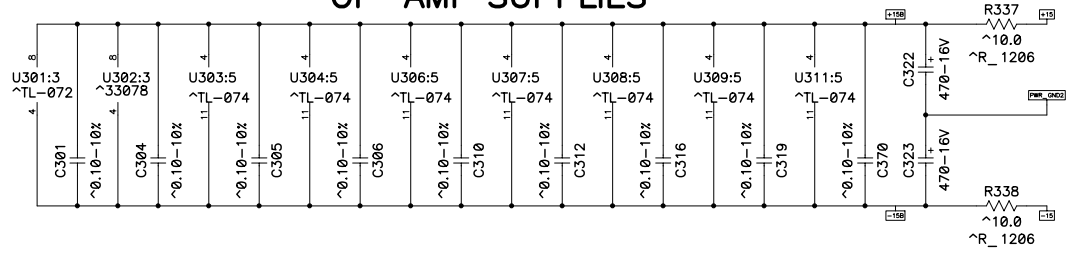

HIGH PERFORMANCE BALANCED INPUT
0.775V (+0dBu, 1Vp) FOR
FULL POWER OUTPUT AT 12 O'CLOCK
0.1% LINE INPUT
XLR-FEM

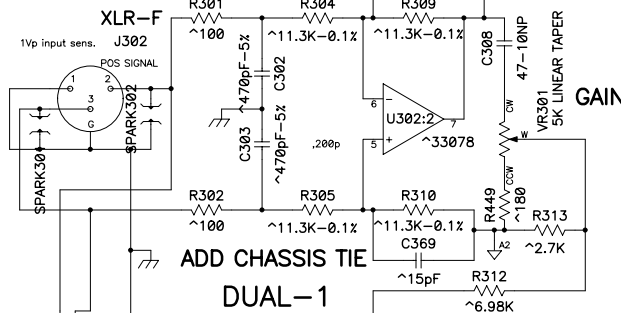

LINE OUTPUT
XLR-MALE
(USE VERT TYPE)

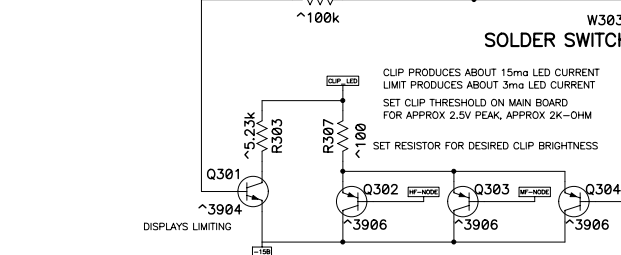
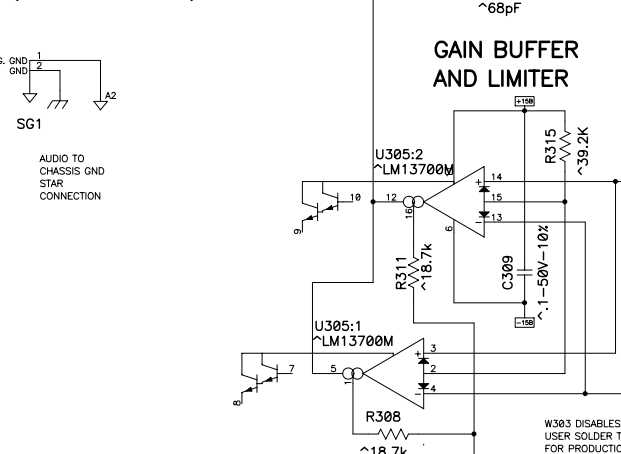

SWITCHABLE 4TH ORDER HP-100Hz UP=BYPASSED

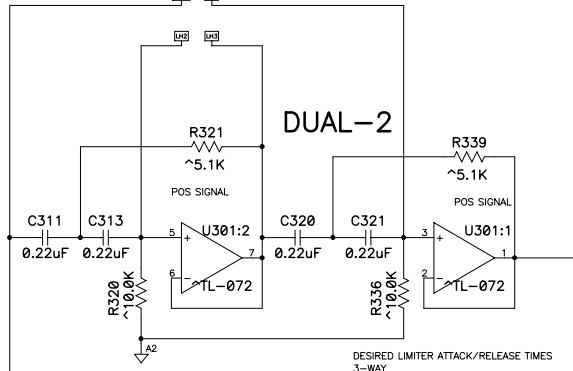

DESIRED LIMITER ATTACK/RELEASE TIMES
3-WAY
*LF ATTACK - 2.76S, RELEASE - 4.76S
*MF ATTACK - 232ms, RELEASE - 521ms
*HF ATTACK - 22ms, RELEASE - 32ms
2-WAY
*LF ATTACK - 3S, RELEASE - 4.7S
*HF ATTACK - 21ms, RELEASE 32ms
1% SUB
*ATTACK - 300ms, RELEASE - 475ms
1% SUB
*ATTACK - 300ms, RELEASE - 560ms

LIMITER CONTROL PROCESSING

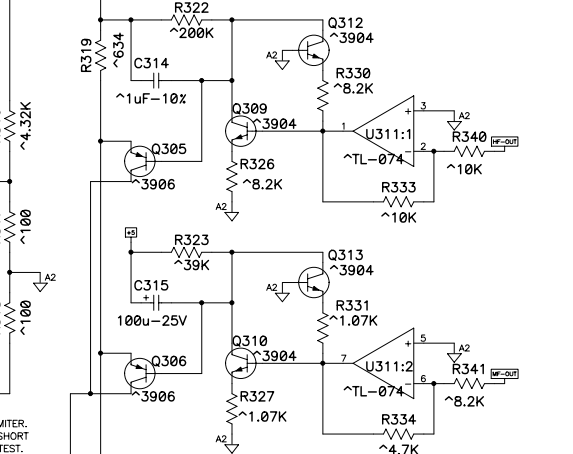

TO FRONT MOUNTED LED (SWITCHABLE) SIGNAL-PRESENCE LED DRIVER

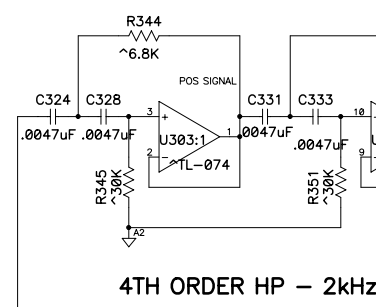
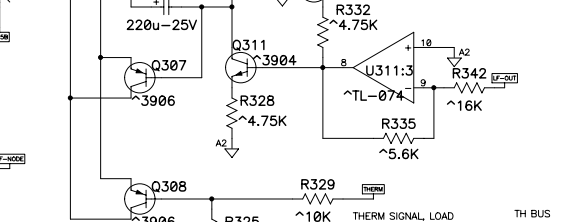

4TH ORDER HP - 2kHz QUAD-3

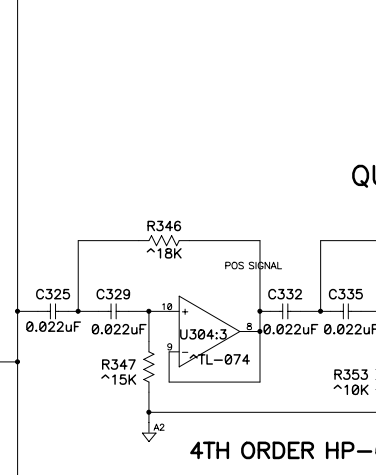

4TH ORDER HP - 600Hz QUAD-5

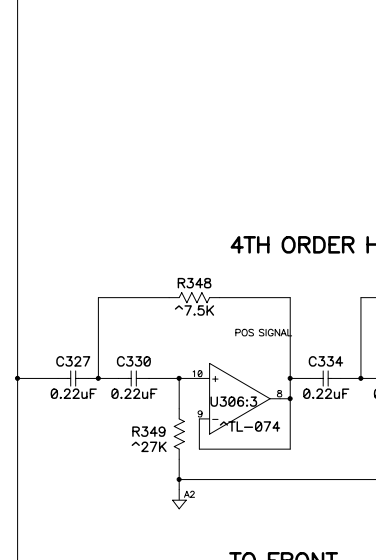

4TH ORDER HP - 40Hz QUAD-7

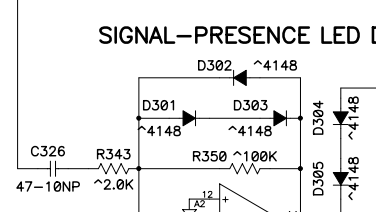

4TH ORDER LP - 2kHz QUAD-8

4TH ORDER LP, 600Hz

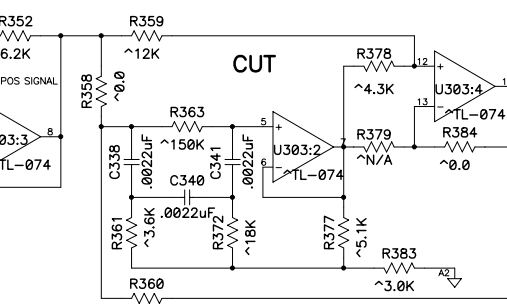

HIGH FREQ PROCESSING QUAD-4

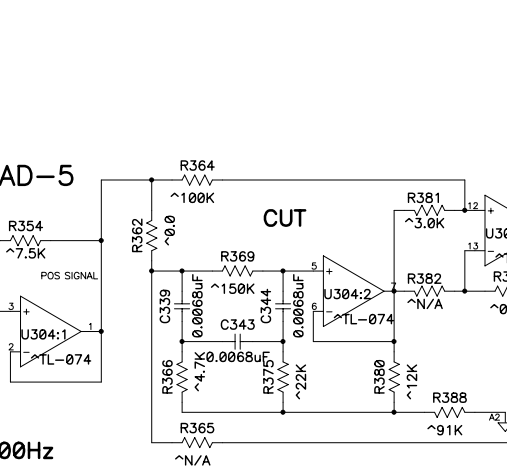

MID FREQ PROCESSING QUAD-6

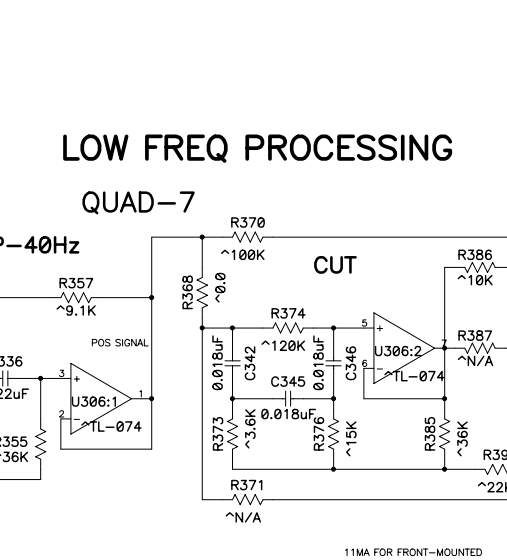

LOW FREQ PROCESSING QUAD-7

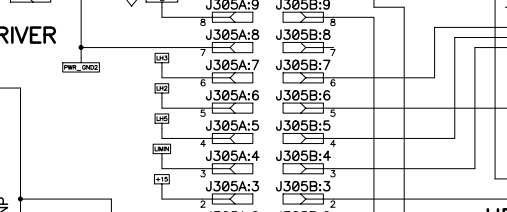

4TH ORDER LP - 600Hz QUAD-8

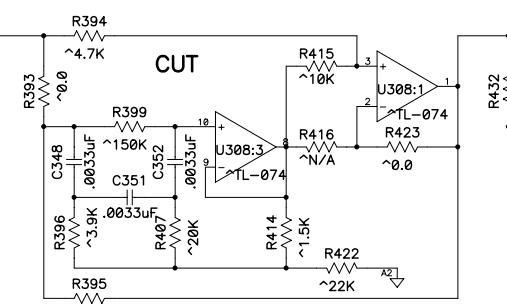

BOOST QUAD-4

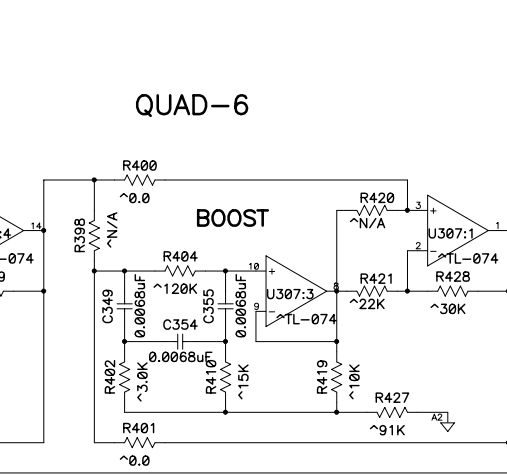

BOOST QUAD-6

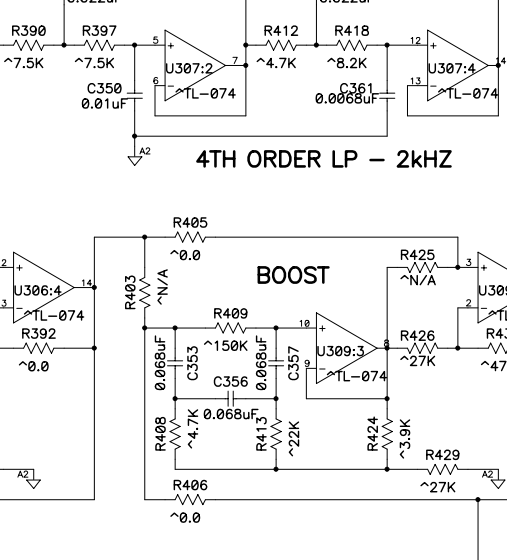

BOOST QUAD-8

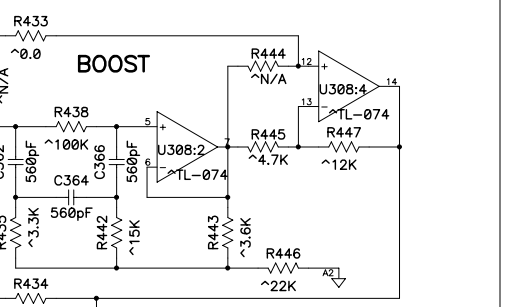

-2.5dB HF GAIN ADJUSTMENT

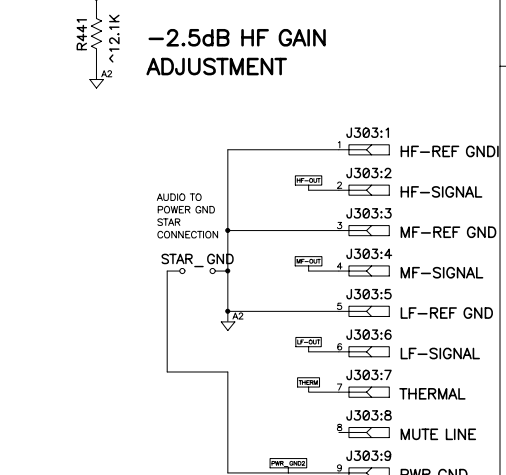

-1dB MF GAIN ADJUSTMENT

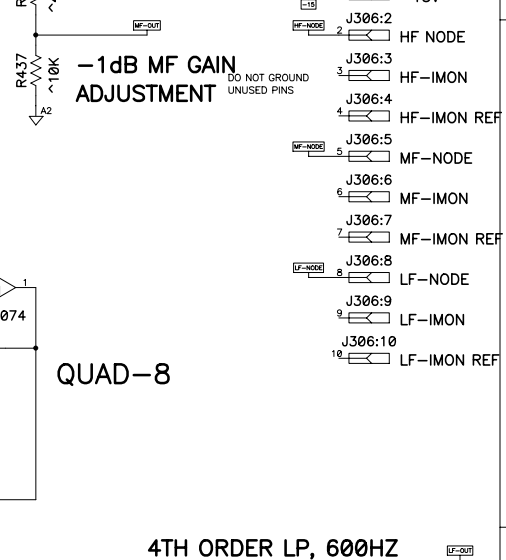

4TH ORDER LP, 600Hz

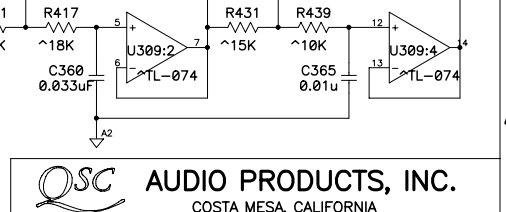

PANEL-PWR PANEL-SIG PANEL-CLIP-LIM

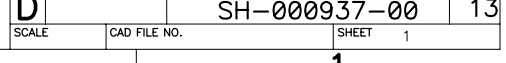

4TH ORDER LP, 600Hz

QSC AUDIO PRODUCTS, INC.
COSTA MESA, CALIFORNIA

HPR153F INPUT BOARD

DO NOT RENUMBER !! STARTS 301

SIZE FSCM NO. DWG NO. REV
D 13 SH-000937-00 13
SCALE CAD FILE NO. SHEET 1

SH-000937-00

REV 13

SHEET 1

THIS DOCUMENT CONTAINS PROPRIETARY INFORMATION WHICH IS THE PROPERTY OF QSC AUDIO PRODUCTS, THAT MAY NOT BE DISCLOSED, REPRODUCED OR USED WITHOUT EXPRESS WRITTEN CONSENT FROM QSC AUDIO PRODUCTS.

J1 AND J3B ARE CONNECTORS ON LEADS THAT MATE WITH J2 AND J3, RESPECTIVELY. J1 IS A COMBO OF TRANSFORMER AND RECTIFIER WIRES. J3B COMES FROM THE TRANSFORMER.

6-PIN MATE-N-LOK 2 X 3 PATTERN HAND-SOLDERED TO SOLDER-SIDE OF POWER PCB

RAIL CURRENT REQUIREMENTS:
18 1/2-87Z GRAMP SECTIONS AT 2MA = 28MA
5532 AT 10MA, PLUS DRIVE CURRENTS 18MA
= 40MA OR SO, AT APPROX 20V = 0.8W PER REGULATOR

REV10, 2005-08-19
PILOT REVISION
*R48 ~6.49K, WAS ~7.5K
*R124, R125 ~0.0, WAS ~33
CHANGE BIAS ADJUST NOTES
MOVED THERMAL LIMIT AND BIAS ADJUSTMENT TO COMPENSATE FOR THE RELOCATION OF U4

REV9, 2005-JULY-18
*ADD AUXILIARY SNUBBER FOR EMC
ADD C50 0805 ~0.1uF
ADD R128 ~10 SERIES W/ C50
*UPDATED AUXILIARY RECTIFIERS W/ SMT
D16, D17, D18, D19, D36, D37

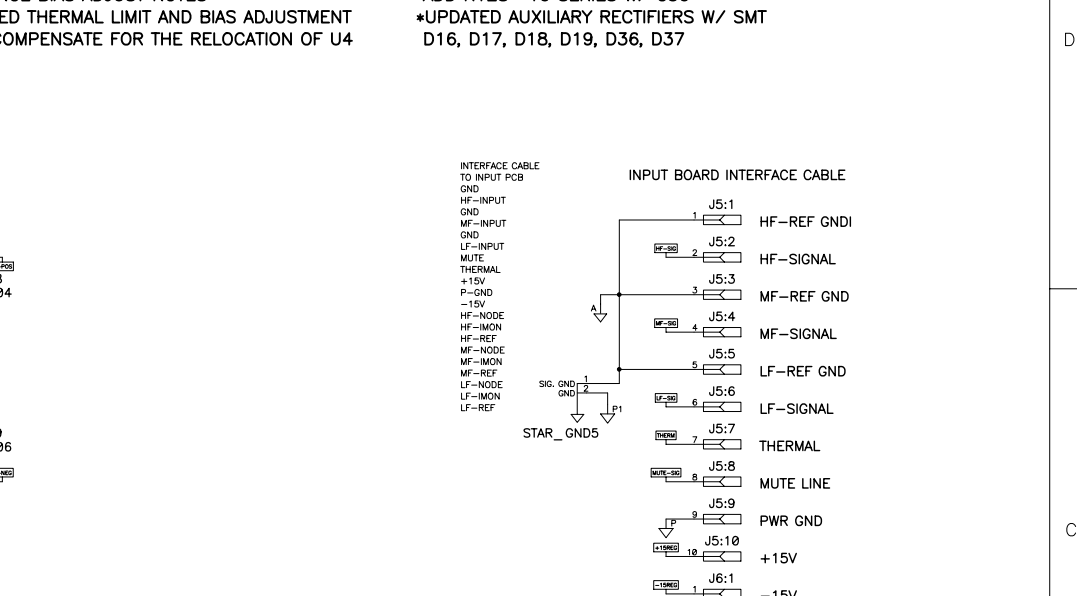
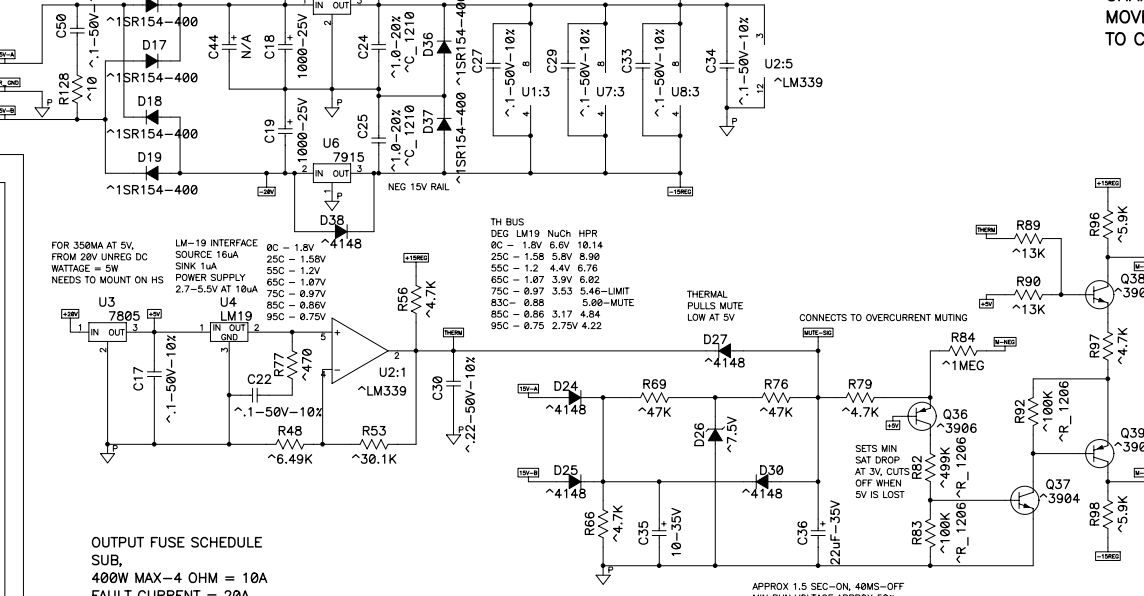
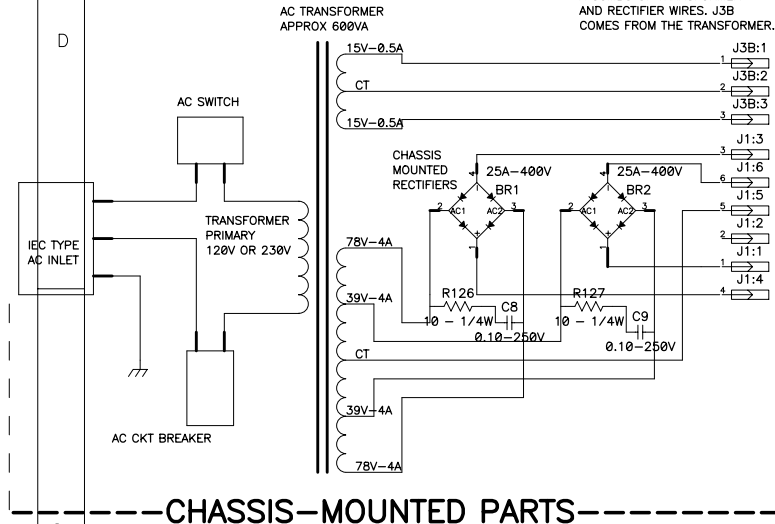

TRANSISTOR POWER-GAIN CALCULATIONS.
TARGET, 400W-8 OHMS = 80V, 10A NOM, 14A PK
RAILS 85V LACED AT 78V, 18V NOM, 125V HI-LINE
XIST PWR, 50V, 6R = 416W/4 = 104W PK
OUTPUT CURRENT, 14A PEAK, BETA = 78, IB = 0.2
--BASE CURRENT, APPROX. 150-400MA (200MA TYP)
--BASE SHUNT, 47 OHM 1.2V, 25MA
DRIVER CURRENT 168-1420MA
--DRIVER BASE, 1-0.4A, 1.5V PK
--DRIVER BASE RES, 1K, 1.9MA PK
CASCODE INPUT CURRENT, 6MA PEAK
--W = 78V-6MA-50 = 216MW MAX

LOW-FREQ AMP, CLASS B
OUTPUT BIAS APPROX 50mV

OUTPUT FUSE SCHEDULE
SUB,
400W MAX-4 OHM = 10A
FAULT CURRENT = 20A
2-WAY AND 3-WAY
200W MAX, LF, BR = 5A,
FAULT CURRENT = 10A
50W MAX, MF-HF BR = 2.5A
FAULT CURRENT = 5A

MID-FREQ AMP,
CLASS AB
OUTPUT BIAS
APPROX 100mV

HI-FREQ AMP,
CLASS AB
OUTPUT BIAS
APPROX 100mV

STAR GROUND
SHOULD BE AT
POWER SUPPLY
CENTER, BTWN
C14 & C15

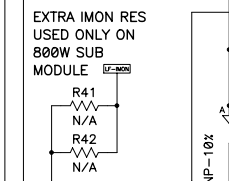

EXTRA IMON RES
USED ONLY ON
800W SUB
MODULE

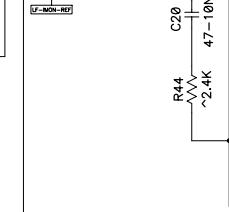

FOR 800W SUBWOOFER MODEL
IN MF-AMP SECTION,
INSTALL ONLY W1, W2, W3, W7, R69, R72, Q34, Q35
FOR 3-WAY USE, OMIT W3, W2, W3, W7, R69, R72

FOR 800W SUBWOOFER MODEL
IN HF AMP SECTION,
INSTALL ONLY W4, W5, W6, W8, R110, R113, Q51, Q52
FOR 3-WAY USE, OMIT W4, W5, W6, W8, R110, R113.

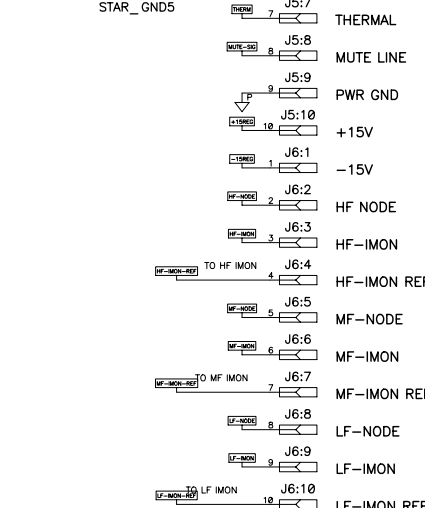
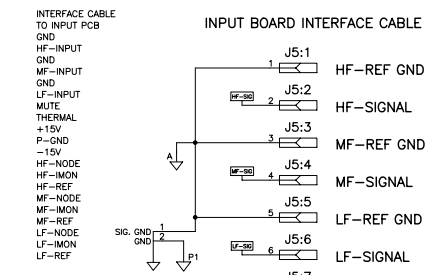

6-PIN MATE-N-LOK 2 X 3 PATTERN HAND-SOLDERED TO SOLDER-SIDE OF POWER PCB

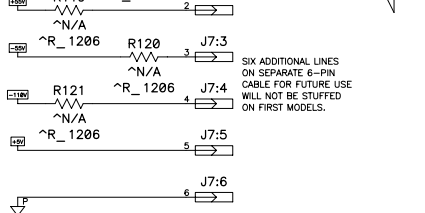
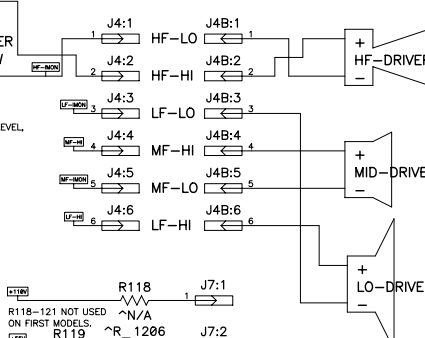

QSC AUDIO PRODUCTS, INC.
COSTA MESA, CALIFORNIA

DO NOT RENUMBER !! HPR153F 3-CH AMPLIFIER

SCALE CAD FILE NO. SHEET SH-000941-00 10

10 1 SH-000941-00

Part Number	Description	Qty	Ref Des
CA-005001-GP	5P, +0.25P, 100V, CTC, 0805, 0/30	1	C39
CA-015005-GP	15PF, 5 PCNT, 50V, CERAMIC, 0805,	2	C368, C369
CA-033003-GP	33PF, 5%, 50V, CC, 0805, 1.2X	2	C11, C12
CA-068003-GP	68PF, 5%, , CTC, 0805, 0/30	1	C307
CA-110005-GP	CC 50V 100PF 5% 0805 1.2	1	C47
CA-110007-GP	100P, 5%, 100V, CTC, 0805, 0/30	1	C49
CA-122005-GP	CC 50V 220PF 5% 0805	5	C31, C42, C45, C46, C6
CA-147006-GP	470PF 5% 50V CER NPO	2	C302, C303
CA-156002-GP	560P, 5%, 50V, CM, , RLT P5.0	3	C362, C364, C366
CA-222014-GP	2200P, 5%, 63V, CM, , RBT	3	C338, C340, C341
CA-222015-GP	2200P, 5%, 50V, CTC, 0805, 0/30	2	C26, C40
CA-233009-GP	3300P, 5%, 100V, CTC, 1206, 0/30	1	C4
CA-233010-GP	3300P, 5%, 63V, CM, , RBT, 7.5X	3	C348, C351, C352
CA-247005-GP	.0047UF, 5 PCNT, 50V, FILM, DIPPED,	4	C324, C328, C331, C333
CA-268002-GP	6800P, 5%, 63V, CM, , RBT	7	C339, C343, C344, C349, C354, C355, C361
CA-310010-GP	0.01U, 5%, 63V, CM, , RBT 7.5X	2	C350, C365
CA-318002-GP	0.018U, 5%, 63V, CM, , RBT	3	C342, C345, C346
CA-322011-GP	0.022U, 5%, 63V, CM, , RBT	6	C325, C329, C332, C335, C347, C359
CA-333001-GP	0.033UF, 5%, 63V, CM, , RB, 7.5	1	C360
CA-368006-GP	.068UF, 5 PCNT, 50V, FILM, ,	4	C353, C356, C357, C358
CA-410014-GP	0.1UF 10% 50V CER X7R 0805	21	C17, C22, C27, C29, C301, C304, C305, C306, C309, C310, C312, C316, C317, C319, C32, C33, C34, C370, C43, C50, C7
CA-410018-GP	CM 250V .1UF 5% RL	2	C8, C9
CA-410023-GP	0.1UF, 5%, 63V, CM, , RBT, 7.5X6	1	C363
CA-410024-GP	CC 200V 0.1U 5% 1210	2	C21, C38
CA-415006-GP	.15UF, 5 PCNT, 200V, CC, 1210,	1	C2
CA-422010-GP	0.22U, 10%, 50V, CC, 0805,	2	C10, C30
CA-422011-GP	0.22U, 5%, 63V, CM, , RBT, 7.5X	8	C311, C313, C320, C321, C327, C330, C334, C336
CA-510016-GP	1U, 10%, 25V, CC, 0805,	1	C314
CA-510017-GP	1UF, 20 PCNT, 50V, CC, SMT, 1210	2	C24, C25
CA-610009-GP	CE 35V 10UF 20% RL 5 X 11	1	C35
CA-622010-GP	22UF, 20%, 35V, CE, , RLT, 5x11	1	C36
CA-647006-GP	CE 16NP 47UF 20% RL	6	C1, C20, C308, C326, C337, C37
CA-710014-GP	100U, 20%, 25V, CE, , RLT, 6X11	1	C315
CA-722007-GP	220UF, 20 PCNT, 25V, CE, RL,	1	C318
CA-747009-GP	470UF, 20%, 16V, CE, , RLT	2	C322, C323
CA-810007-GP	1000UF, 20%, 25V, CE, , RLT	2	C18, C19
CA-868002-GP	6800UF, 20 PCNT, 63V, CE, RL,	4	C13, C14, C15, C16
CH-000173-GP	COVER, XFMR, STEEL, LARGE	1	
CH-000423-GP	PANEL-INPUT, BLACK 153, , HPR,	1	
CH-000425-GP	PANEL-LEFT (AC), BLACK, , HPR,	1	
CH-000489-GP	PLATE-SPRING STEEL, , , ,	5	
CH-000490-GP	HEATSINK, 381X189.2X38.1, , HPR,	1	
CO-000058-GP	XLR, CONNECTOR, 3PM, , ,	1	J301
CO-000204-GP	CONN XLR F VERT PLASTIC	1	J302
CO-000211-GP	AC INLET 250V 15A	1	
CO-000213-GP	CONN 2 PIN STRAIGHT WAFER	1	J304A
CO-000214-GP	CONN 3 PIN STRAIGHT WAFER	1	J3
CO-000281-GP	HDR 6.3MM CNTR 6P(2X3)MALE	2	J2, J4
CO-000349-GP	WIRE HOLDER, RIBBON CABLE, 10 POS, FEMALE,	3	J303, J305B, J306
CO-000350-GP	WIRE TRAP, RIBBON CABLE, 10 POS, FEMALE, RELEASEABLE	3	J305A, J5, J6
HW-000075-GP	FUSE HOLDER, , , , ,	3	F1, F2, F3
HW-000102-GP	BRASS POST, D6X10, , , ,	3	
HW-000103-GP	BRASS POST, D6X8, , , ,	4	
IC-000075-GP	IC VOLTAGE REG, +5, LM78L05, SMT,	1	U310
IC-000076-GP	IC LM339, SMD COMPARATORS, , ,	1	U2
IC-000077-GP	IC LM13700M, , , SMT,	1	U305
IC-000078-GP	IC LM19, THERMAL SENSOR, , TO-92,	1	U4
IC-000079-GP	IC MC33078, OP-AMP, , SMT,	4	U1, U302, U7, U8
IC-000377-GP	IC 7805, REGULATOR, 5V, ,	1	U3
IC-000378-GP	IC LM7915CT, REGULATOR, -15V, ,	1	U6
IC-000379-GP	IC LM7815CT, REGULATOR, 15V, ,	1	U5
IC-000380-GP	IC TL072, OPAMP, DUAL, SO-8,	1	U301
IC-000381-GP	IC TL074CD-SO14, OPAMP, QUAD, SO-14,	7	U303, U304, U306, U307, U308, U309, U311
LB-000530-GP	PC INLAY, WARNING LABEL, , ,	1	
MS-000070-GP	2.5A, FAST ACT 5X20, , ,	2	F2, F3
MS-000073-GP	FUSE, FAST, ACTING 5A, SMT, 1206,	2	F4, F5
MS-000292-GP	FUSE, 6.3A, 5 X 20MM, FAST,	1	F1
NW-000002-GP	SPRING WASHER, 3M, , , , , , , ,	4	
NW-000069-GP	SPRING WASHER, M4X1X7, BZ, ,	2	
NW-000070-GP	M3, NUT, , , , ,	7	
NW-000071-GP	M4, NUT, , BLACK, ,	2	
NW-000072-GP	NUT, HEX, M4, ,	1	
NW-000073-GP	FLAT WASHER, M4X0.8X9.7, , ,	4	
NW-040002-GP	SPRING WASHER M4 X 7	1	
NW-040003-GP	I/T WASHER M4X0.4X8, YZ	1	
PC-001534-00	PCB MAIN, HPR, ,	1	
PC-001535-00	PCB, INPUT, HPR, , FULL RANGE	1	
PL-000066-GP	EVA GASKET, 5X500, , , ,	3	
PL-000152-GP	CABLE TIE, ISA	4	
PL-000327-GP	PAD, XFMR, EPDM 40A, 1/8" THK, BLACK,	2	
PL-000391-GP	KNOB, GAIN, HPR SERIES, , ,	1	
PL-000454-GP	INSULATION SHEET IC, , , SILPAD 800, ,	5	
PL-000455-GP	LED HOLDER, LED3-11, , , , ,	3	LD301-1, LD302-1, LD303-1
PL-000456-GP	SPRINGSEAT, TRANSISTOR, HPR, NYLON, ,	5	
PL-000457-GP	SPACER, L=4.0, ELM 3, , ,	1	U4
PL-000458-GP	SPONGE CUSHION, , , , ,	2	
PT-110002-GP	TRIM, 100, 20 PCNT, 0.15W, , ,	3	VR1, VR2, VR3
PT-250003-GP	VR 5K, XVB12111NPNV25F, , , ,	1	VR301
QD-000201-GP	DIODE LL4148 SM	15	D10, D11, D12, D20, D24, D25, D27, D30, D301, D302, D303, D304, D305, D38, D8
QD-000204-GP	XISTOR NPN 60V 200MA 3904 SOT-23	23	Q11, Q16, Q2, Q24, Q25, Q28, Q3, Q301, Q309, Q310, Q311, Q312, Q313, Q314, Q315, Q33, Q37, Q38, Q41, Q42, Q45, Q50, Q6

Part Number	Description	Qty	Ref Des
QD-000205-GP	XISTOR PNP 40V 0.2A TR3906 SOT-23	20	Q1, Q10, Q17, Q19, Q23, Q29, Q302, Q303, Q304, Q305, Q306, Q307, Q308, Q32, Q36, Q39, Q40, Q46, Q49, Q7
QD-000206-GP	DIOD RECT FAST, IN4934 AT	12	D1, D2, D22, D23, D28, D29, D32, D33, D34, D35, D4, D5
QD-000208-GP	XISTOR PNP 230V 15A 2SA1943	4	Q12, Q14, Q34, Q51
QD-000209-GP	XISTOR NPN 230V 15A 2SC5200	4	Q13, Q15, Q35, Q52
QD-000227-GP	BRIDGE RECT 400V 25A	2	BR1, BR2
QD-000260-GP	MOSFET, N-CH, 60V, 52A, 52N06V	2	Q21, Q22
QD-000300-GP	LED SC, 2.9 X 5.4 XL 0.5 BL, , , , ,	1	LD302
QD-000301-GP	LED, 3MM, GREEN SP, , , ,	1	LD303
QD-000302-GP	LED SP, 2.9 X 5.4 XL 0.5 RED, , , , ,	1	LD301
QD-000303-GP	DIODE, BAV21WS 250V, , , , ,	5	D21, D3, D31, D6, D9
QD-000304-GP	DIODE, MUR810 RL 8A, , , , ,	2	D13, D15
QD-000305-GP	DZ 1/2W, 6.2VB RLZ6.2B, , , , SMT,	2	D14, D7
QD-000306-GP	DZ 1/2W, 7.5VB RLZ7.5B LL, , , , SMT,	1	D26
QD-000307-GP	SMD DIODE, ISR154-400, , , , ,	6	D16, D17, D18, D19, D36, D37
QD-000308-GP	TR MMBA42 NPN SMD, , , , , SOT-23,	4	Q20, Q27, Q44, Q5
QD-000309-GP	TR 2SA1837, 100-320 RL, , , , ,	3	Q26, Q4, Q43
QD-000310-GP	TR 2SC4793, 100-320-RL, , , , ,	3	Q31, Q48, Q9
QD-000311-GP	TR MMBA92 SOT 23 KEC, , , , ,	4	Q18, Q30, Q47, Q8
RE-01002-GP	0.1R, 5 PCNT, 2W, RMF, ATS METAL,	12	R115, R116, R117, R25, R26, R27, R28, R29, R30, R74, R75, R78
RE-47006-GP	RMF, 1W, 4R7, 5%, AT,	3	R49, R6, R88
RE-000003-GP	RMG 1/10W 0 OHM 5% 0805	17	R103, R124, R125, R358, R362, R368, R384, R389, R392, R393, R400, R401, R405, R406, R423, R433, R434
RE-001009-GP	10 1% 1/8W THK FLM 1206	2	R337, R338
RE-001012-GP	10OHM, 1/4W, 1%, AT, RMF,	2	R126, R127
RE-001013-GP	10, 1 PCNT, 1/10W, THICK FILM, 0805,	1	R128
RE-004753-GP	RMG 1/10W 47.5 OHM 1% 0805	13	R109, R110, R111, R112, R113, R21, R22, R23, R24, R67, R68, R71, R72
RE-010011-GP	100 1% 1/10W THK FLM 0805 100V	17	R103, R104, R107, R108, R14, R15, R19, R20, R301, R302, R307, R317, R318, R60, R61, R64, R65
RE-018001-GP	180R, 1 PCNT, 1/10W, RMG, 0805,	2	R449, R8
RE-020003-GP	200 1% 1/10W THK FLM 0805 100V	1	R93
RE-030006-GP	300 OHM, 1 PCNT, 1/10W, THICK FILM, 0805,	1	R51
RE-040200-GP	402R, 1 PCNT, 1/10W, RMG, 0805,	2	R436, R95
RE-047012-GP	470, 1 PCNT, 1/10W, THICK FILM, 0805,	1	R77
RE-063405-GP	634 OHMS 1% 1/10W 0805	1	R319
RE-091002-GP	910R, 1 PCNT, 1/10W, RMG, 0805,	14	R100, R101, R105, R106, R11, R12, R17, R18, R54, R57, R58, R62, R63, R9
RE-110702-GP	1.07K, 1 PCNT, 1/10W, RMG, 0805,	2	R327, R331
RE-115008-GP	1.5K, 1 PCNT, 1/10W, THK FLM, 0805, 100V	2	R414, R440
RE-120004-GP	RMG 1/10W 2K 1% 0805	1	R343
RE-122010-GP	2.2K 1% 1/10W THK FM 0805 100V	3	R102, R16, R59
RE-124001-GP	2.4K, 1 PCNT, 1/10W, RMG, 0805,	4	R2, R35, R44, R81
RE-127001-GP	2.7K, 1 PCNT, 1/10W, RMG, 0805,	1	R313
RE-130006-GP	3K, 1 PCNT, 1/10W, THICK FILM, 0805,	3	R381, R383, R402
RE-130103-GP	RMG 1/10W 3.01K 1% 0805	1	R33
RE-133008-GP	3.3K, 1 PCNT, 1/10W, THICK FILM, 0805,	1	R435
RE-136003-GP	3.6K, 1 PCNT, 1/10W, RMG, 0805,	3	R361, R373, R443
RE-139006-GP	3.9K, 1 PCNT, 1/10W, THICK FILM, 0805,	3	R396, R411, R424
RE-143001-GP	4.3K, 1 PCNT, 1/10W, RMG, 0805,	1	R378
RE-143202-GP	4.32K, 1 PCNT, 1/10W, RMG, 0805,	1	R316
RE-147002-GP	4.7K 1% 1/10W THK FLM 0805	11	R334, R366, R39, R394, R408, R412, R445, R56, R66, R79, R97
RE-147506-GP	4.75K, 1 PCNT, 1/10W, THICK FILM, 0805,	2	R328, R332
RE-151006-GP	5.1K, 1 PCNT, 1/10W, THICK FILM, 0805,	4	R321, R339, R377, R451
RE-152302-GP	5.23K, 1 PCNT, 1/10W, THICK FILM, 0805,	1	R303
RE-156004-GP	5.6K, 1 PCNT, 1/10W, THICK FILM, 0805,	1	R335
RE-159003-GP	5.9K 1% 1/10W THK FLM 0805	2	R96, R98
RE-162001-GP	6.2K, 1 PCNT, 1/10W, RMG, 0805,	1	R352
RE-164901-GP	6.49K, 1 PCNT, 1/10W, RMG, 0805,	1	R48
RE-168007-GP	6.8K, 1 PCNT, 1/10W, RMG, 0805,	1	R344
RE-169802-GP	6.98K, 1 PCNT, 1/10W, THK FLM, 0805, 100V	1	R312
RE-175004-GP	7.5K 1% 1/10W THK FM 0805 100V	4	R348, R354, R390, R397
RE-182007-GP	8.2K, 1 PCNT, 1/10W, THICK FILM, 0805,	4	R326, R330, R341, R418
RE-191001-GP	9.1K, 1 PCNT, 1/10W, RMG, 0805,	1	R357
RE-210007-GP	10K 1% 1/10W THK FLM 0805	20	R1, R122, R3, R320, R329, R333, R336, R340, R353, R386, R415, R419, R43, R437, R439, R45, R50, R7, R80, R85
RE-211305-GP	11.3K .1% 1/10W RMG 0805	4	R304, R305, R309, R310
RE-212003-GP	12K 1% 1/10W THK FLM 0805 100V	3	R359, R380, R447
RE-212004-GP	12K, 1 PCNT, 1/8W, THICK FILM, 1206,	1	R448
RE-212105-GP	12.1K, 1 PCNT, 1/10W, RMG, 0805,	1	R441
RE-213005-GP	13K, 1 PCNT, 1/10W, RMG, 0805,	3	R36, R89, R90
RE-215003-GP	15K, 1 PCNT, 1/10W, RMG, 0805,	5	R347, R376, R410, R431, R442
RE-216001-GP	16K, 1 PCNT, 1/10W, RMG, 0805,	1	R342
RE-218006-GP	18K, 1 PCNT, 1/10W, THICK FILM, 0805,	4	R346, R372, R417, R91
RE-218702-GP	18.7K, 1 PCNT, 1/10W, THICK FILM, 0805,	2	R308, R311
RE-220005-GP	RMG 1/10W 20K 1% 0805	3	R407, R46, R86
RE-220006-GP	20K, 1 PCNT, 1/10W, THICK FILM, 1206,	1	R38
RE-222001-GP	22K 1% 1/10W 0805	9	R32, R34, R37, R375, R391, R413, R421, R422, R446
RE-227001-GP	27K 1% 1/10W 0805	3	R349, R426, R429
RE-230006-GP	30K, 1 PCNT, 1/10W, THICK FILM, 0805,	4	R345, R351, R4, R428
RE-230104-GP	30.1K 1% 1/8W RMG 1206	4	R40, R47, R5, R87
RE-230105-GP	30.1K, 1 PCNT, 1/10W, THICK FILM, 0805,	1	R53
RE-236001-GP	36K, 1 PCNT, 1/10W, RMG, 0805,	2	R355, R385
RE-239003-GP	39K, 1 PCNT, 1/10W, MET FLM, 0805, 100V	1	R323
RE-239204-GP	39.2K, 1 PCNT, 1/10W, THICK FILM, 0805,	3	R315, R325, R356
RE-247006-GP	47K 1% 1/10W THK FLM 0805 100V	3	R430, R69, R76
RE-275005-GP	75K, 1 PCNT, 1/10W, RMG, ,	1	R314
RE-291001-GP	91K, 1 PCNT, 1/10W, RMG, 0805,	3	R367, R388, R427
RE-310007-GP	100K 1% 1/10W THK FLM 0805	5	R306, R350, R364, R370, R438
RE-310008-GP	100K 1% 1/8W THK FLM 1206	6	R10, R31, R52, R83, R92, R94
RE-312006-GP	120K 1% 1/10W RMG 0805	2	R374, R404
RE-315006-GP	150K, 1 PCNT, 1/10W, THICK FILM, 0805,	5	R324, R363, R369, R399, R409
RE-320006-GP	200K, 1 PCNT, 1/10W, THICK FILM, 0805,	1	R322
RE-349901-GP	499K 1% 1/8W THICK FILM 1206	1	R82
RE-410003-GP	1M 1% 1/10W RMG 0805	4	R13, R55, R84, R99
SC-000079-GP	SCREW, MACH, M4X19, , , BLACK, ZN	2	

Part Number	Description	Qty	Ref Des
SC-000080-GP	METAL SCREW, M4*14, TTP/B, . . .	16	
SC-000081-GP	T3X8MM, SELF TAPPING, . . .	2	
SC-000082-GP	SCREW, BIND, HEAD, M3.2 X 8, . B-TITE,	6	
SC-000083-GP	SCREW, BIND, HEAD, M3.5 X 16, . B-TITE,	10	
SC-000084-GP	SCREW, BIND, SERRATED HEAD, M4X25, B-TITE,	4	
SC-000085-GP	SELF SCREW, 3X8, WITH, SERRATED HEAD, . .	2	
SC-000086-GP	SCREW, M8X101.5, BZ, . . .	1	
SC-030002-GP	M3 B-TITE FLAT-CS	2	
SC-030004-GP	M3 X 8 BLK MACHINE	6	
SC-030008-GP	SCREW M3X6 BLK TAP	4	
SW-000088-GP	ROCKER POWER SWITCH	1	
SW-000093-GP	CIRCUIT BREAKER, 5 AMP, .	1	
SW-000119-GP	CIRCUIT BREAKER, 3A, 230V, HPR,	1	
SW-000122-GP	SWITCH, 1P2T, . .	1	SW302
SW-000123-GP	SWITCH, 2P2T, . .	1	SW301
WC-000188-GP	SLEEVE, PVC, 5MM ID, BLK	0	
WC-000410-GP	UL1672, AWG#18, BROWN,	0	
WC-000411-GP	UL1672, AWG#18, BLUE,	0	
WC-000412-GP	GRND WIRE, UL1015 #14,	1	
WC-000413-GP	WIRE-FLAT, 10P P1.5 #26,	3	J303, J305B, J306
WC-000423-GP	SHRINKAGE TUBE, ID=6MM, UL,	0	
XF-000293-GP	POWER TRANSFORMER, 120V, . . . , HPR SERIES, .	1	

Part Number	Description	Qty	Ref Des
CA-005001-GP	5P, +0.25P, 100V, CTC, 0805, 0/30	1	C39
CA-015005-GP	15PF, 5 PCNT, 50V, CERAMIC, 0805,	2	C368, C369
CA-033003-GP	33PF, 5%, 50V, CC, 0805, 1.2X	2	C11, C12
CA-068003-GP	68PF, 5%, , CTC, 0805, 0/30	1	C307
CA-110005-GP	CC 50V 100PF 5% 0805 1.2	1	C47
CA-110007-GP	100P, 5%, 100V, CTC, 0805, 0/30	1	C49
CA-122005-GP	CC 50V 220PF 5% 0805	5	C31, C42, C45, C46, C6
CA-147006-GP	470PF 5% 50V CER NPO	2	C302, C303
CA-156002-GP	560P, 5%, 50V, CM, , RLT P5.0	3	C362, C364, C366
CA-222014-GP	2200P, 5%, 63V, CM, , RBT	3	C338, C340, C341
CA-222015-GP	2200P, 5%, 50V, CTC, 0805, 0/30	2	C26, C40
CA-233009-GP	3300P, 5%, 100V, CTC, 1206, 0/30	1	C4
CA-233010-GP	3300P, 5%, 63V, CM, , RBT, 7.5X	3	C348, C351, C352
CA-247005-GP	.0047UF, 5 PCNT, 50V, FILM, DIPPED,	4	C324, C328, C331, C333
CA-268002-GP	6800P, 5%, 63V, CM, , RBT	7	C339, C343, C344, C349, C354, C355, C361
CA-310010-GP	0.01U, 5%, 63V, CM, , RBT 7.5X	2	C350, C365
CA-318002-GP	0.018U, 5%, 63V, CM, , RBT	3	C342, C345, C346
CA-322011-GP	0.022U, 5%, 63V, CM, , RBT	6	C325, C329, C332, C335, C347, C359
CA-333001-GP	0.033UF, 5%, 63V, CM, , RB, 7.5	1	C360
CA-368006-GP	.068UF, 5 PCNT, 50V, FILM, ,	4	C353, C356, C357, C358
CA-410014-GP	0.1UF 10% 50V CER X7R 0805	21	C17, C22, C27, C29, C301, C304, C305, C306, C309, C310, C312, C316, C317, C319, C32, C33, C34, C370, C43, C50, C7
CA-410018-GP	CM 250V .1UF 5% RL	2	C8, C9
CA-410023-GP	0.1UF, 5%, 63V, CM, , RBT, 7.5X6	1	C363
CA-410024-GP	CC 200V 0.1U 5% 1210	2	C21, C38
CA-415006-GP	.15UF, 5 PCNT, 200V, CC, 1210,	1	C2
CA-422010-GP	0.22U, 10%, 50V, CC, 0805,	2	C10, C30
CA-422011-GP	0.22U, 5%, 63V, CM, , RBT, 7.5X	8	C311, C313, C320, C321, C327, C330, C334, C336
CA-510016-GP	1U, 10%, 25V, CC, 0805,	1	C314
CA-510017-GP	1UF, 20 PCNT, 50V, CC, SMT, 1210	2	C24, C25
CA-610009-GP	CE 35V 10UF 20% RL 5 X 11	1	C35
CA-622010-GP	22UF, 20%, 35V, CE, , RLT, 5x11	1	C36
CA-647006-GP	CE 16NP 47UF 20% RL	6	C1, C20, C308, C326, C337, C37
CA-710014-GP	100U, 20%, 25V, CE, , RLT, 6X11	1	C315
CA-722007-GP	220UF, 20 PCNT, 25V, CE, RL,	1	C318
CA-747009-GP	470UF, 20%, 16V, CE, , RLT	2	C322, C323
CA-810007-GP	1000UF, 20%, 25V, CE, , RLT	2	C18, C19
CA-868002-GP	6800UF, 20 PCNT, 63V, CE, RL,	4	C13, C14, C15, C16
CH-000173-GP	COVER, XFMR, STEEL, LARGE	1	
CH-000423-GP	PANEL-INPUT, BLACK 153, , HPR,	1	
CH-000425-GP	PANEL-LEFT (AC), BLACK, , HPR,	1	
CH-000489-GP	PLATE-SPRING STEEL, , , ,	5	
CH-000490-GP	HEATSINK, 381X189.2X38.1, , HPR,	1	
CO-000058-GP	XLR, CONNECTOR, 3PM, , ,	1	J301
CO-000204-GP	CONN XLR F VERT PLASTIC	1	J302
CO-000211-GP	AC INLET 250V 15A	1	
CO-000213-GP	CONN 2 PIN STRAIGHT WAFER	1	J304A
CO-000214-GP	CONN 3 PIN STRAIGHT WAFER	1	J3
CO-000281-GP	HDR 6.3MM CNTR 6P(2X3)MALE	2	J2, J4
CO-000349-GP	WIRE HOLDER, RIBBON CABLE, 10 POS, FEMALE,	3	J303, J305B, J306
CO-000350-GP	WIRE TRAP, RIBBON CABLE, 10 POS, FEMALE, RELEASEABLE	3	J305A, J5, J6
HW-000075-GP	FUSE HOLDER, , , , ,	3	F1, F2, F3
HW-000102-GP	BRASS POST, D6X8, , , ,	3	
HW-000103-GP	BRASS POST, D6X8, , , ,	4	
IC-000075-GP	IC VOLTAGE REG, +5, LM78L05, SMT,	1	U310
IC-000076-GP	IC LM339, SMD COMPARATORS, , ,	1	U2
IC-000077-GP	IC LM13700M, , , SMT,	1	U305
IC-000078-GP	IC LM19, THERMAL SENSOR, , TO-92,	1	U4
IC-000079-GP	IC MC33078, OP-AMP, , SMT,	4	U1, U302, U7, U8
IC-000377-GP	IC 7805, REGULATOR, 5V, , ,	1	U3
IC-000378-GP	IC LM7915CT, REGULATOR, -15V, , ,	1	U6
IC-000379-GP	IC LM7815CT, REGULATOR, 15V, , ,	1	U5
IC-000380-GP	IC TL072, OPAMP, DUAL, SO-8,	1	U301
IC-000381-GP	IC TL074CD-SO14, OPAMP, QUAD, SO-14,	7	U303, U304, U306, U307, U308, U309, U311
LB-000530-GP	PC INLAY, WARNING LABEL, , ,	1	
MS-000070-GP	2.5A, FAST ACT 5X20, , , ,	2	F2, F3
MS-000073-GP	FUSE, FAST, ACTING 5A, SMT, 1206,	2	F4, F5
MS-000292-GP	FUSE, 6.3A, 5 X 20MM, FAST,	1	F1
NW-000002-GP	SPRING WASHER, 3M, , , , , , ,	4	
NW-000069-GP	SPRING WASHER, M4X1X7, BZ, , ,	2	
NW-000070-GP	M3, NUT, , , , ,	7	
NW-000071-GP	M4, NUT, , BLACK, , ,	2	
NW-000072-GP	NUT, HEX, M4, , ,	1	
NW-000073-GP	FLAT WASHER, M4X0.8X9.7, , , ,	4	
NW-040002-GP	SPRING WASHER M4 X 7	1	
NW-040003-GP	I/T WASHER M4X0.4X8, YZ	1	
PC-001534-00	PCB MAIN, HPR, , ,	1	
PC-001535-00	PCB, INPUT, HPR, , FULL RANGE	1	
PL-000066-GP	EVA GASKET, 5X500, , , ,	3	
PL-000152-GP	CABLE TIE, ISA	4	
PL-000327-GP	PAD, XFMR, EPDM 40A, 1/8" THK, BLACK,	2	
PL-000391-GP	KNOB, GAIN, HPR SERIES, , ,	1	
PL-000454-GP	INSULATION SHEET IC, , , SILPAD 800, ,	5	
PL-000455-GP	LED HOLDER, LED3-11, , , , ,	3	LD301-1, LD302-1, LD303-1
PL-000456-GP	SPRINGSEAT, TRANSISTOR, HPR, NYLON, ,	5	
PL-000457-GP	SPACER, L=4.0, ELM 3, , , ,	1	U4
PL-000458-GP	SPONGE CUSHION, , , , , ,	2	
PT-110002-GP	TRIM, 100, 20 PCNT, 0.15W, , ,	3	VR1, VR2, VR3
PT-250003-GP	VR 5K, XVB12111YNPVB25F, , , ,	1	VR301

Part Number	Description	Qty	Ref Des
QD-000201-GP	DIODE LL4148 SM	15	D10, D11, D12, D20, D24, D25, D27, D30, D301, D302, D303, D304, D305, D38, D8
QD-000204-GP	XISTOR NPN 60V 200MA 3904 SOT-23	23	Q11, Q16, Q2, Q24, Q25, Q28, Q3, Q301, Q309, Q310, Q311, Q312, Q313, Q314, Q315, Q33, Q37, Q38, Q41, Q42, Q45, Q50, Q6
QD-000205-GP	XISTOR PNP 40V 0.2A TR3906 SOT-23	20	Q1, Q10, Q17, Q19, Q23, Q29, Q302, Q303, Q304, Q305, Q306, Q307, Q308, Q32, Q36, Q39, Q40, Q46, Q49, Q7
QD-000206-GP	DIOD RECT FAST, IN4934 AT	12	D1, D2, D22, D23, D28, D29, D32, D33, D34, D35, D4, D5
QD-000208-GP	XISTOR PNP 230V 15A 2SA1943	4	Q12, Q14, Q34, Q51
QD-000209-GP	XISTOR NPN 230V 15A 2SC5200	4	Q13, Q15, Q35, Q52
QD-000227-GP	BRIDGE RECT 400V 25A	2	BR1, BR2
QD-000260-GP	MOSFET, N-CH, 60V, 52A, 52N06V	2	Q21, Q22
QD-000300-GP	LED SC, 2.9 X 5.4 XL 0.5 BL, , , , ,	1	LD302
QD-000301-GP	LED, 3MM, GREEN SP, , , ,	1	LD303
QD-000302-GP	LED SP, 2.9 X 5.4 XL 0.5 RED, , , , ,	1	LD301
QD-000303-GP	DIODE, BAV21WS 250V, , , , ,	5	D21, D3, D31, D6, D9
QD-000304-GP	DIODE, MUR810 RL 8A, , , , ,	2	D13, D15
QD-000305-GP	DZ 1/2W, 6.2VB RLZ6.2B, , , , SMT,	2	D14, D7
QD-000306-GP	DZ 1/2W, 7.5VB RLZ7.5B LL, , , , SMT,	1	D26
QD-000307-GP	SMD DIODE, ISR154-400, , , , ,	6	D16, D17, D18, D19, D36, D37
QD-000308-GP	TR MMBTA42 NPN SMD, , , , , SOT-23,	4	Q20, Q27, Q44, Q5
QD-000309-GP	TR 2SA1837, 100-320 RL, , , , ,	3	Q26, Q4, Q43
QD-000310-GP	TR 2SC4793, 100-320-RL, , , , ,	3	Q31, Q48, Q9
QD-000311-GP	TR MMBTA92 SOT 23 KEC, , , , ,	4	Q18, Q30, Q47, Q8
RE-01002-GP	0.1R, 5 PCNT, 2W, RMF, ATS METAL,	12	R115, R116, R117, R25, R26, R27, R28, R29, R30, R74, R75, R78
RE-47006-GP	RMF, 1W, 4R7, 5%, AT,	3	R49, R6, R88
RE-000003-GP	RMG 1/10W 0 OHM 5% 0805	17	R123, R124, R125, R358, R362, R368, R384, R389, R392, R393, R400, R401, R405, R406, R423, R433, R434
RE-001009-GP	10 1% 1/8W THK FLM 1206	2	R337, R338
RE-001012-GP	100HM, 1/4W, 1%, AT, RMF,	2	R126, R127
RE-001013-GP	10, 1 PCNT, 1/10W, THICK FILM, 0805,	1	R128
RE-004753-GP	RMG 1/10W 47.5 OHM 1% 0805	13	R109, R110, R111, R112, R113, R21, R22, R23, R24, R67, R68, R71, R72
RE-010011-GP	100 1% 1/10W THK FLM 0805 100V	17	R103, R104, R107, R108, R14, R15, R19, R20, R301, R302, R307, R317, R318, R60, R61, R64, R65
RE-018001-GP	180R, 1 PCNT, 1/10W, RMG, 0805,	2	R449, R8
RE-020003-GP	200 1% 1/10W THK FLM 0805 100V	1	R93
RE-030006-GP	300 OHM, 1 PCNT, 1/10W, THICK FILM, 0805,	1	R51
RE-040200-GP	402R, 1 PCNT, 1/10W, RMG, 0805,	2	R436, R95
RE-047012-GP	470, 1 PCNT, 1/10W, THICK FILM, 0805,	1	R77
RE-063405-GP	634 OHMS 1% 1/10W 0805	1	R319
RE-091002-GP	910R, 1 PCNT, 1/10W, RMG, 0805,	14	R100, R101, R105, R106, R11, R12, R17, R18, R54, R57, R58, R62, R63, R9
RE-110702-GP	1.07K, 1 PCNT, 1/10W, RMG, 0805,	2	R327, R331
RE-115008-GP	1.5K, 1 PCNT, 1/10W, THK FLM, 0805, 100V	2	R414, R440
RE-120004-GP	RMG 1/10W 2K 1% 0805	1	R343
RE-122010-GP	2.2K 1% 1/10W THK FM 0805 100V	3	R102, R16, R59
RE-124001-GP	2.4K, 1 PCNT, 1/10W, RMG, 0805,	4	R2, R35, R44, R81
RE-127001-GP	2.7K, 1 PCNT, 1/10W, RMG, 0805,	1	R313
RE-130006-GP	3K, 1 PCNT, 1/10W, THICK FILM, 0805,	3	R381, R383, R402
RE-130103-GP	RMG 1/10W 3.01K 1% 0805	1	R33
RE-133008-GP	3.3K, 1 PCNT, 1/10W, THICK FILM, 0805,	1	R435
RE-136003-GP	3.6K, 1 PCNT, 1/10W, RMG, 0805,	3	R361, R373, R443
RE-139006-GP	3.9K, 1 PCNT, 1/10W, THICK FILM, 0805,	3	R396, R411, R424
RE-143001-GP	4.3K, 1 PCNT, 1/10W, RMG, 0805,	1	R378
RE-143202-GP	4.32K, 1 PCNT, 1/10W, RMG, 0805,	1	R316
RE-147002-GP	4.7K 1% 1/10W THK FLM 0805	11	R334, R366, R39, R394, R408, R412, R445, R56, R66, R79, R97
RE-147506-GP	4.75K, 1 PCNT, 1/10W, THICK FILM, 0805,	2	R328, R332
RE-151006-GP	5.1K, 1 PCNT, 1/10W, THICK FILM, 0805,	4	R321, R339, R377, R451
RE-152302-GP	5.23K, 1 PCNT, 1/10W, THICK FILM, 0805,	1	R303
RE-156004-GP	5.6K, 1 PCNT, 1/10W, THICK FILM, 0805,	1	R335
RE-159003-GP	5.9K 1% 1/10W THK FLM 0805	2	R96, R98
RE-162001-GP	6.2K, 1 PCNT, 1/10W, RMG, 0805,	1	R352
RE-164901-GP	6.49K, 1 PCNT, 1/10W, RMG, 0805,	1	R48
RE-168007-GP	6.8K, 1 PCNT, 1/10W, RMG, 0805,	1	R344
RE-169802-GP	6.98K, 1 PCNT, 1/10W, THK FLM, 0805, 100V	1	R312
RE-175004-GP	7.5K 1% 1/10W THK FM 0805 100V	4	R348, R354, R390, R397
RE-182007-GP	8.2K, 1 PCNT, 1/10W, THICK FILM, 0805,	4	R326, R330, R341, R418
RE-191001-GP	9.1K, 1 PCNT, 1/10W, RMG, 0805,	1	R357
RE-210007-GP	10K 1% 1/10W THK FLM 0805	20	R1, R122, R3, R320, R329, R333, R336, R340, R353, R386, R415, R419, R43, R437, R439, R45, R50, R7, R80, R85
RE-211305-GP	11.3K .1% 1/10W RMG 0805	4	R304, R305, R309, R310
RE-212003-GP	12K 1% 1/10W THK FLM 0805 100V	3	R359, R380, R447
RE-212004-GP	12K, 1 PCNT, 1/8W, THICK FILM, 1206,	1	R448
RE-212105-GP	12.1K, 1 PCNT, 1/10W, RMG, 0805,	1	R441
RE-213005-GP	13K, 1 PCNT, 1/10W, RMG, 0805,	3	R36, R89, R90
RE-215003-GP	15K, 1 PCNT, 1/10W, RMG, 0805,	5	R347, R376, R410, R431, R442
RE-216001-GP	16K, 1 PCNT, 1/10W, RMG, 0805,	1	R342
RE-218006-GP	18K, 1 PCNT, 1/10W, THICK FILM, 0805,	4	R346, R372, R417, R91
RE-218702-GP	18.7K, 1 PCNT, 1/10W, THICK FILM, 0805,	2	R308, R311
RE-220005-GP	RMG 1/10W 20K 1% 0805	3	R407, R46, R86
RE-220006-GP	20K, 1 PCNT, 1/10W, THICK FILM, 1206,	1	R38
RE-222001-GP	22K 1% 1/10W 0805	9	R32, R34, R37, R375, R391, R413, R421, R422, R446
RE-227001-GP	27K 1% 1/10W 0805	3	R349, R426, R429
RE-230006-GP	30K, 1 PCNT, 1/10W, THICK FILM, 0805,	4	R345, R351, R4, R428
RE-230104-GP	30.1K 1% 1/8W RMG 1206	4	R40, R47, R5, R87
RE-230105-GP	30.1K, 1 PCNT, 1/10W, THICK FILM, 0805,	1	R53
RE-236001-GP	36K, 1 PCNT, 1/10W, RMG, 0805,	2	R355, R385
RE-239003-GP	39K, 1 PCNT, 1/10W, MET FLM, 0805, 100V	1	R323
RE-239204-GP	39.2K, 1 PCNT, 1/10W, THICK FILM, 0805,	3	R315, R325, R356
RE-247006-GP	47K 1% 1/10W THK FLM 0805 100V	3	R430, R69, R76
RE-275005-GP	75K, 1 PCNT, 1/10W, RMG, ,	1	R314
RE-291001-GP	91K, 1 PCNT, 1/10W, RMG, 0805,	3	R367, R388, R427
RE-310007-GP	100K 1% 1/10W THK FLM 0805	5	R306, R350, R364, R370, R438
RE-310008-GP	100K 1% 1/8W THK FLM 1206	6	R10, R31, R52, R83, R92, R94
RE-312006-GP	120K 1% 1/10W RMG 0805	2	R374, R404
RE-315006-GP	150K, 1 PCNT, 1/10W, THICK FILM, 0805,	5	R324, R363, R369, R399, R409

Part Number	Description	Qty	Ref Des
RE-320006-GP	200K, 1 PCNT, 1/10W, THICK FILM, 0805,	1	R322
RE-349901-GP	499K 1% 1/8W THICK FILM 1206	1	R82
RE-410003-GP	1M 1% 1/10W RMG 0805	4	R13, R55, R84, R99
SC-000079-GP	SCREW, MACH, M4X19, , , BLACK, ZN	2	
SC-000080-GP	METAL SCREW, M4*14, TTP/B, , ,	20	
SC-000081-GP	T3X8MM, SELF TAPPING, , , ,	2	
SC-000082-GP	SCREW, BIND, HEAD, M3.2 X 8, , B-TITE,	6	
SC-000083-GP	SCREW, BIND, HEAD, M3.5 X 16, , B-TITE,	10	
SC-000084-GP	SCREW, BIND, SERRATED HEAD, M4X25, B-TITE,	4	
SC-000085-GP	SELF SCREW, 3X8, WITH, SERRATED HEAD, , ,	2	
SC-000086-GP	SCREW, M8X101.5, BZ, , , ,	1	
SC-030002-GP	M3 B-TITE FLAT-CS	2	
SC-030004-GP	M3 X 8 BLK MACHINE	6	
SC-030008-GP	SCREW M3X6 BLK TAP	4	
SW-000088-GP	ROCKER POWER SWITCH	1	
SW-000119-GP	CIRCUIT BREAKER, 3A, 230V, HPR,	1	
SW-000122-GP	SWITCH, 1P2T, , ,	1	SW302
SW-000123-GP	SWITCH, 2P2T, , ,	1	SW301
WC-000188-GP	SLEEVE, PVC, 5MM ID, BLK	0	
WC-000410-GP	UL1672, AWG#18, BROWN, , , , ,	0	
WC-000411-GP	UL1672, AWG#18, BLUE, , , , ,	0	
WC-000412-GP	GRND WIRE, UL1015 #14, , , , ,	1	
WC-000413-GP	WIRE-FLAT, 10P P1.5 #26, , , , ,	3	J303, J305B, J306
WC-000423-GP	SHRINKAGE TUBE, ID=6MM, UL, , , , ,	0	
XF-000294-GP	POWER TRANSFORMER, 230V, , , , HPR SERIES, ,	1	