

QUAD 44

Control Unit

INSTRUCTION BOOK

IMPORTANT

PLEASE READ THE INSTRUCTION BOOK CAREFULLY
BEFORE ATTEMPTING TO MAKE ANY CONNECTIONS TO
THE QUAD 44.

CONTENTS

Page Number

Preamble

Accessory Packing 2

Service 2

Guarantee 2

Introduction 3

Installation 3

Connections 4

A.C. Input and Outputs 4

Fuse 5

Output to Power Amplifier 5

Input Modules: Disc 6

 Moving Coil Disc 8

 Tape Replay and Record 8

 Radio and Aux. 12

 Changing Input Modules 13

Operation 14

Controls 14

Operating Summary 14

Circuit Diagrams 14

The Acoustical Manufacturing Co. Ltd.,
HUNTINGDON,
Cambs.
PE18 7DB.

Telephone No.: Huntingdon (0480) 52561
Telex: 32348 QUAD G

Quad is a registered trade mark

Accessory Pack Contents

- 1 × AC connector (export models AC lead).
- 1 × control unit to power amplifier AC lead 2 metres.
- 1 × 4 pin/4 pin Din signal lead 2 metres.
- 2 × 5 pin Din plugs.
- 2 × AC outlet connectors.

Service

If servicing is required the pre-amplifier should be returned to the supplier, to the distributor for the country of purchase or to the Acoustical Manufacturing Co. Ltd. A brief note should be enclosed giving your name and address plus the reason for returning it.

IMPORTANT

THE CARDBOARD CARTON AND EXPANDED POLYSTYRENE PACK SHOULD BE RETAINED IN CASE THE UNIT HAS TO BE RETURNED TO THE MANUFACTURER OR DISTRIBUTOR FOR SERVICE.

Guarantee

This pre-amplifier is guaranteed against any defect in material and workmanship for a period of twelve months from the date of purchase.

Within this period we undertake to supply replacement parts free of charge provided that failure was not occasioned by misuse, accident or negligence. Labour and carriage costs are not covered unless by local agreement.

Within the U.K. the guarantee offered with this equipment does not limit the consumer's existing statutory rights.

INTRODUCTION

The Quad 44 control unit accepts the outputs from a variety of sources, pickup, tape recorder, radio tuner, and amplifies the selected source up to amplifier input level.

At the same time the Quad 44 provides the listener with the means to compensate for certain effects of the listening environment and programme balance. The results obtained from almost any programme material can be improved by intelligent use of the Tilt, Bass and Filter controls.

The Quad 44 retains all the beneficial characteristics of its predecessors, the Quad 33 and Quad 22, while incorporating a number of significant and worthwhile improvements in both performance and ergonomics.

INSTALLATION

The Quad 44 is designed to be used either free standing or installed in a cabinet. While not unduly sensitive to induced hum from stray fields, the complete system should be assembled before a final installation is made, to ensure that there are no unforeseen difficulties of operation or wiring up.

Hum is usually due to external connections, such as pickup wiring, double earthing, mains cable lying close to the pickup leads etc, in which case the hum level will increase as the Volume control is advanced.

If the hum level remains constant irrespective of Volume control setting, then the source is probably internal, or may be due to a stray external field such as from a mains transformer close to the control unit.

When the Quad 44 is to be mounted in a cabinet or a panel you will require an aperture 312mm × 89mm as shown in Fig. 1. The cover is removed from the Quad 44, the unit passed through the aperture from the front so that its lugs locate in the aperture, and the cover replaced from the rear, thus gripping the cabinet panel between the Quad 44 front casting and its cover. The securing screws should be inserted finger tight and then given one further halfturn to lock the unit firmly in position.

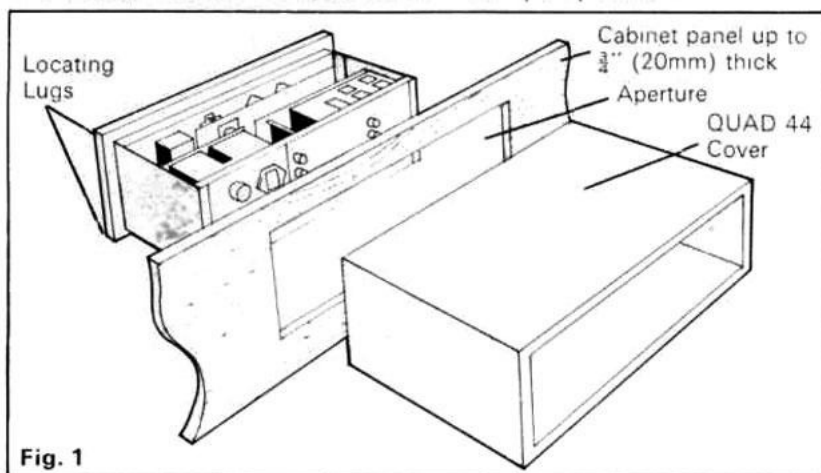

CONNECTIONS

A.C. Input and Outputs

The Quad 44 is double insulated, dual voltage, and complies with all relevant international safety standards. Mains input is via a standard three pin Euro plug and socket, supplied with the unit, which should be wired in accordance with the internationally agreed code, Green/Yellow earth, Brown live and Blue neutral.

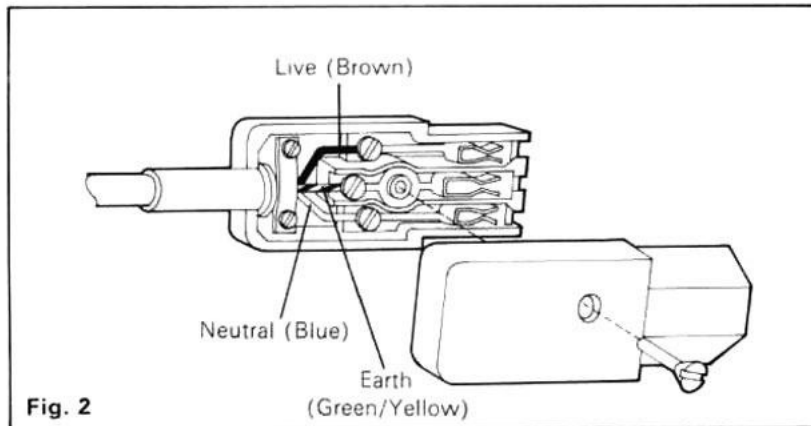

The Quad 44 is suitable for use on 100–120/200–240V 50/60Hz supplies selected by a switch on the power supply box at the back of the unit. Mains voltage of 10% above and below the indicated ranges will not affect the specified performance.



Three switched A.C. outlets are provided to power ancillary equipment such as the power amplifier, radio tuner, turntable etc. The A.C. outlets are three pin, with the earth (ground) connected directly to the incoming mains earth. When connecting double insulated and other equipment using two conductor mains cable, the earth pin on the plug may be ignored.

The Quad 44 is supplied with a power cord for use with the Quad 405 and two additional plugs.

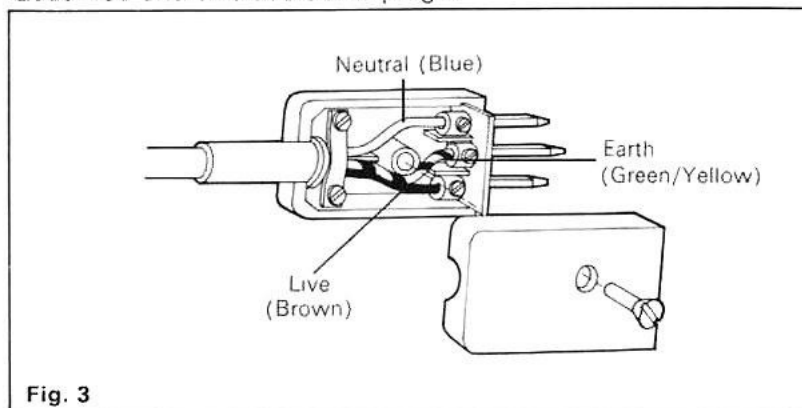

Fig. 3

The maximum total steady current drawn from these outlets should not exceed 4 amps.

This is sufficient to power a Quad 405 amplifier, Quad FM tuner, and turntable, tape recorder or electrostatic loudspeakers. It is recommended that power amplifiers with outputs greater than 150 watts per channel and fitted with on/off switches be powered directly from a wall socket and not from the A.C. outlets on the back of the control unit.

IMPORTANT

BEFORE CONNECTING THE A.C. SUPPLY CHECK TO BE ABSOLUTELY SURE THAT THE CORRECT VOLTAGE SETTING HAS BEEN CHOSEN.

Fuse

The primary of the mains transformer is fitted with a 100mA fuse to protect the Quad 44 in the event of a component failure.

Output to Power Amplifier

The Quad 44 is equipped with two outputs, via a 4 pin Din socket at 0.5V rms, suitable for the Quad 303, Quad 405 and other similar amplifiers, and via phono sockets at up to 5V rms for amplifiers with input sensitivities of .775V and above. Both outputs may be used simultaneously. A 4 pin Din signal lead is supplied to interconnect the Quad 44 and Quad power amplifier.

INPUTS

Disc

Input to the Disc pre-amplifier is via a 5 pin Din socket or phono sockets.

The standard Disc module offers three input sensitivities each with two alternative loads, either $47k\Omega$ resistance only or $47k\Omega$ in parallel with $180pF$, selected by a switch bank located under the transparent flap on the top cover.

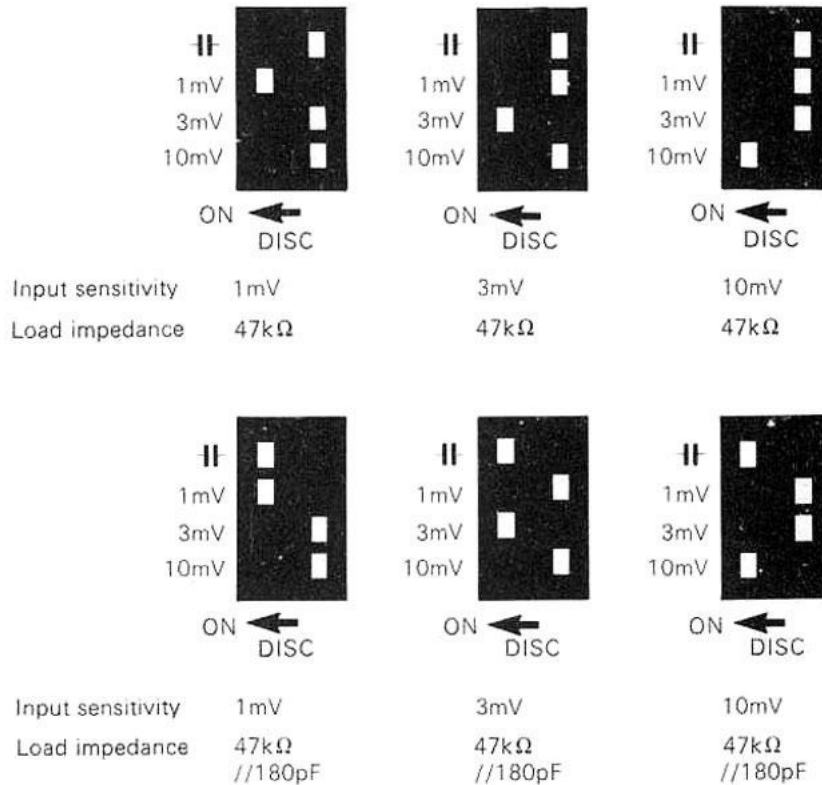

The output of your pickup cartridge is specified in mV at a given velocity, normally 5cms/second, together with a recommended load.

To obtain the correct sensitivity of the Disc input simply select the switch position which corresponds closest to the specified output of the cartridge. Where the recommended load is in excess of $150pF$ switch in the extra capacitance. Remember

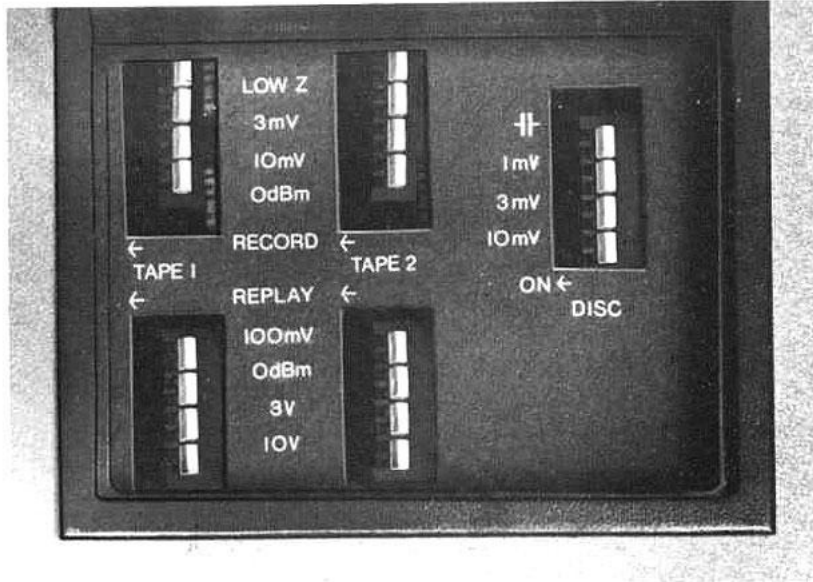

Switch bank

that the capacity of the pickup lead (normally between 75pF and 150pF depending on the make) must be added to that of the pre-amplifier to obtain the actual load presented to the cartridge. For example, for a cartridge with a quoted output of 3.5mV and recommended load of 47k Ω and 250–350pF select the switches as shown

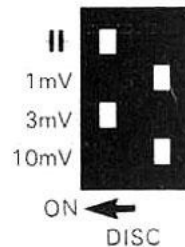

Input sensitivity 3mV

Load impedance 47k Ω //180pF

This setting is correct for the large majority of existing high quality moving magnet cartridges. Errors of ± 50 pF in capacitor matching are not critical.

In exceptional cases where the recommended load is in excess of 350pF capacitors C300 and C303 may be changed to a higher value.

To avoid hum in pickup installations, the pickup arm should be connected to the turntable chassis, when this is equipped with a three core mains cable, and earthed in the switched A.C. outlet on the rear of the Quad 44. Refer to the section on A.C. Outputs page 4. When the turntable is equipped with a two core mains cable the pickup arm should be bonded to the signal earth. On turntables which are supplied complete with arm, this will already have been done and the pickup may be connected to the Din or phono sockets as appropriate.

Where a separate arm is used, it may be necessary to connect the arm earth lead to the shell of the Din plug, or one of the two phono plugs, or to the screen of the pickup lead. In case of difficulty consult your dealer.

Moving Coil Disc

An alternative Disc input module, which can be used in place of the standard Disc module, or any other input module, offers 20dB greater input sensitivity for use with low output moving coil cartridges, and can be obtained from your dealer. Refer to page 13. 'Changing Input Modules'

Tape

Two identical Tape modules are supplied as standard, with connections via a 5 pin Din socket.

Each 5 pin Din socket carries both the record and replay signals as shown.

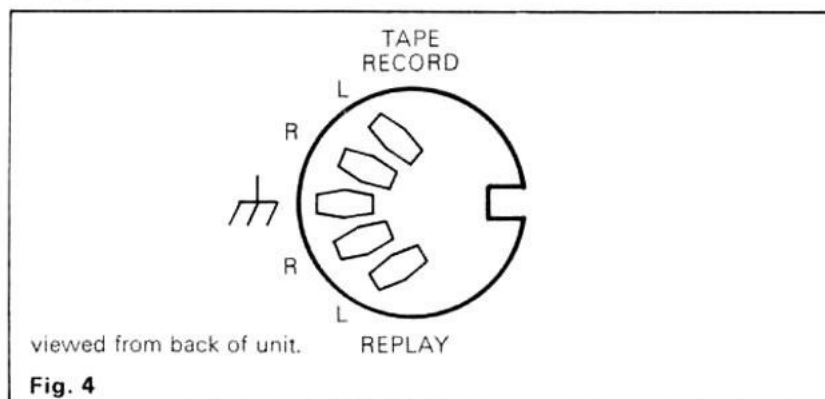

Each Tape module has five input replay sensitivities and four record output levels selected by switches in exactly the same manner as for the Disc input and is suitable for use with all commercially available tape machines, both cassette and reel to reel.

Record

The record outlet of the Quad 44 has two source impedance settings, Low Z suitable for all tape recorder inputs except those which are Din compatible, and High Z ($30k\Omega$) for Din compatible inputs. Note that not all tape recorder inputs with Din sockets are Din compatible. Din compatible inputs can be recognised easily since the Din specification requires from 0.1mV to 1mV of input signal per $k\Omega$ of input impedance. Thus a tape machine with a Din input of specified impedance of $2k\Omega$ and a nominal sensitivity of 0.2mV is Din compatible and you would select

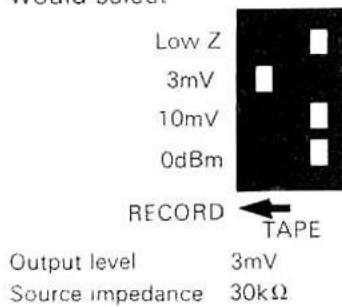

For all high impedance inputs (i.e. 50k or greater), whether equipped with phono sockets or Din plugs, select the Low Z position and the appropriate output level. Four output levels are available and selected as follows

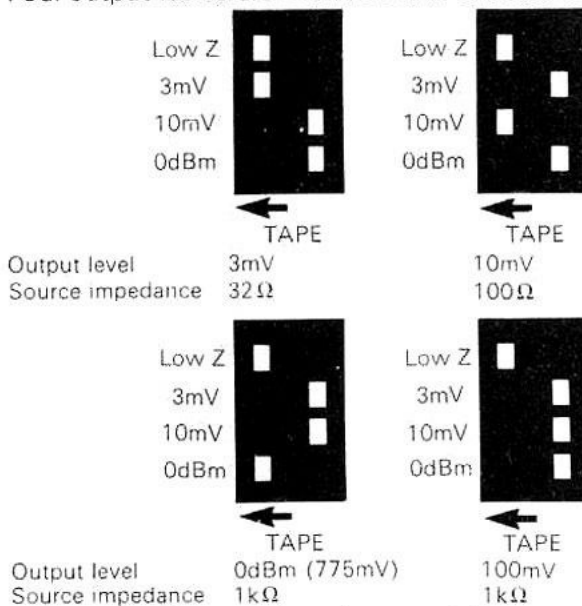

Low Z is shown selected as would be the case with all but Din compatible inputs. The 0dBm (775mV) switch also acts as a $\times 8$ multiplier when used with either of the other two output level switches, so that selecting 3mV and 0dBm provides 24mV output, 10mV and 0dBm provides 80mV.

Replay

Five replay sensitivity settings are available as follows –

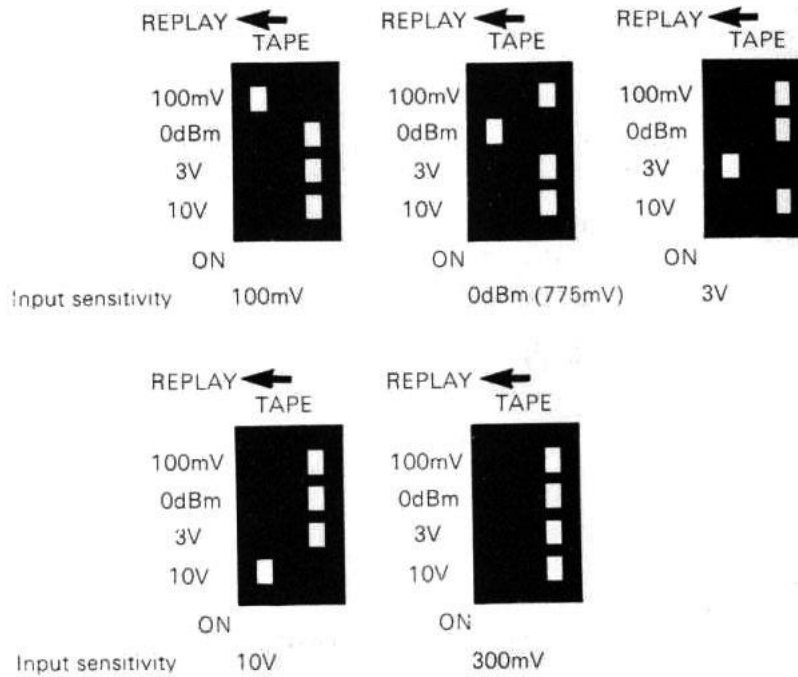

No impedance matching problems occur on replay.

Setting Record and Replay Levels

To find the appropriate settings consult the specification of the tape machine in question. The relevant sections are input sensitivity and output level. Choose the appropriate input and output and select the record and replay settings which are closest to their quoted levels.

In the absence of exact figures for the tape recorder the correct settings may be found by experiment, being those settings which provide good recording and replay levels with reasonable settings of any record level and volume controls involved.

For example

TAPE RECORDER

QUAD 44

**Recording
Inputs**

Sensitivity Impedance

Din ·2mV 2kΩ

or

Line 60mV 100kΩ

**Replay
Outlets**

Din 420mV

or

Line ·775V

Record

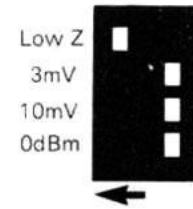
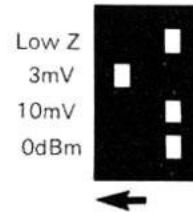

Replay

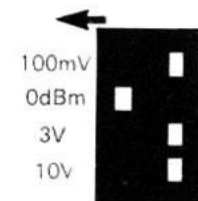
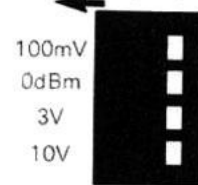

Tape Recording

Recordings can be made from either or both Tape outputs simply by setting the relevant tape machines to record. Monitoring facilities are provided for each Tape module simply by pressing the appropriate red pushbutton marked M.

To revert to the input signal, press the appropriate input button, indicated by the illuminated green LED.

Dubbing from Tape 1 to Tape 2 or vice versa is straightforward. To dub from Tape 1 to Tape 2, set the first tape recorder (cassette or open reel) to replay, press Tape 1, and set the second tape recorder to record. Pressing M2 will monitor the signal recorded on the second tape machine.

Simply reverse the procedure to dub from Tape 2 to Tape 1.

One or other of the Tape input/outputs can also be used for connecting an equaliser or noise reduction unit into the system. The Tape record outputs are unaffected by any of the controls. It is also possible to record from Disc or Radio on to one tape machine and at the same time to listen to a different programme from a second tape machine. Simply press Disc (or Radio) and set the first tape machine to Record. Set the second tape machine to Replay and press the Monitor button for Tape 2. Pressing Monitor for Tape 1 enables you to check that all is well with your recording, and pressing Monitor for Tape 2 returns you to the programme to which you were listening. Do not press either Tape 1 or Tape 2 buttons as this will interrupt the recording. The reverse also applies so that you can record on Tape 2 and listen to Tape 1.

Any suitable source fed into either of the tape inputs may be used in this way, and if a different input module, for example Disc is used in place of one of the Tape input modules then a signal fed into it can be listened to when the Monitor button is pressed without interrupting the recording from another source.

Radio and Auxiliary

The Radio and Auxiliary inputs are identical and use 5 pin Din Sockets. Load impedance at $1\text{M}\Omega$ is high, and as well as accepting the output from any radio tuner, can be used as the input for a ceramic cartridge, for a microphone pre-amplifier, or a P.C.M. laser disc player.

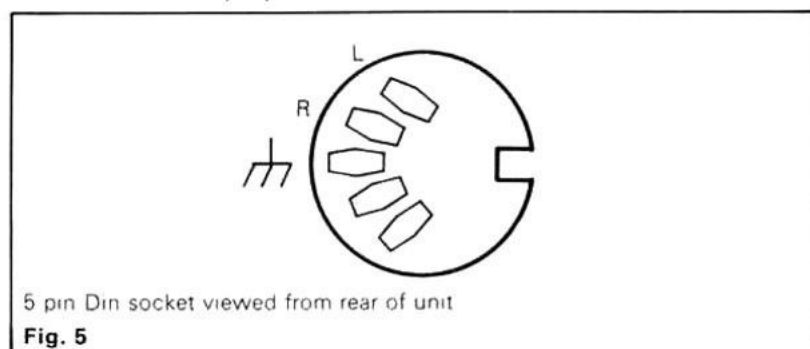

Changing Input Modules

Any of the input modules can be quite simply replaced by any other. Removing the cover of the control unit gives access to the two screws which hold each input module in place. Remove the appropriate screws and the module can be withdrawn.

When replacing the module take great care to ensure that each of the gold plated pins on the motherboard is properly located in its appropriate contact on the input board. This operation is easier if the switch cover is removed. The switch cover is held in place by a small black peg.

The Quad 44 control unit is highly versatile and can have any combination of inputs required. For example, a third (and fourth and fifth) Tape module could be added in place of the Auxiliary input etc, with the facility to dub from any machine to either or both of the other two (three or four), or five Disc input modules could be used to provide a handy comparator.

Servicing is greatly simplified, and the Quad 44 is ideally suited to take advantage of any future developments in programme source.

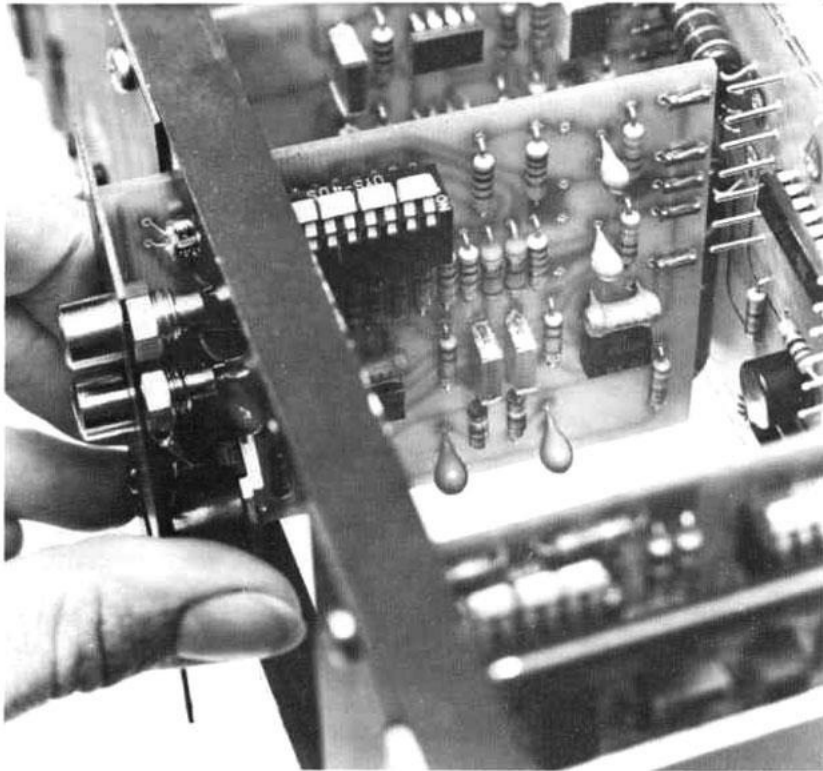

Replacing a module

OPERATION

The Quad 44 is switched on by pressing the button to the right of and below the Volume control.

The Quad 44 automatically selects the Radio input when switched on, irrespective of the last input in use.

The desired input is selected by pressing the appropriate pushbutton. A green LED indicates the input selected. To change from one input to another simply press the button for the new input required. Switching is entirely electronic and totally silent, so it is not necessary to reduce the volume while changing from one input to another, and since the inputs are totally isolated it is not necessary to switch off the programme source when not in use.

Volume Control

The Volume control is of the detent type, accurately balanced between channels and with a law carefully designed to give the listener maximum control at normal listening levels when the input sensitivity has been correctly matched to the programme source. The Volume control knob positions are numbered to provide a convenient reference. The numbers are not related to the attenuation of the control.

The correct setting of the Volume control is largely determined by the perspective of the recording or broadcast.

TONE CONTROLS

The results obtained from any programme depend upon the aggregate effect of the listening room, the recording environment together with corrections applied by the recording engineer, and characteristics, minimal with first class equipment, of the various elements of the reproducing chain. It is not difficult to understand that it is extremely unlikely that the arbitrary combination of these variables which occurs when listening at home will yield the closest approach to the original sound, and indeed it is only necessary to play a good recording on first class equipment in a number of different rooms to realise just how much variation there can be.

Environmental effects are delayed in time with respect to the original sound so that only certain types of error are correctable by frequency response shaping.

Traditional Bass and Treble controls have very limited use and are more suitable for correcting transducer failings than acoustic problems. The graphic equaliser is exceedingly versatile but with high built-in redundancy because problems amenable to correction are confined to clearly defined parts of the musical spectrum.

The tone controls on the Quad 44 are designed to enable the listener to obtain the closest approach to the original sound with the assumption that only first class pickups and loudspeakers will be used. The operation of each of the controls is described in some detail below.

Tilt, Bass and Filter

With the Filter switch in the Cancel position, the Tilt and Bass controls are bypassed to give a level response and as a ready reference point to enable the listener to check that the corrections which have been applied with the Tilt, Bass and Filter controls give a genuine improvement. A small red LED gives visual confirmation when the Cancel position is selected. These controls have been designed so that, used intelligently, the listener can improve the results from all but the very best programmes. The controls are carefully calibrated and marked so that once a suitable setting has been found for a particular record or recording, it is readily repeatable. For the Tilt, Bass or Filter controls to function the Filter switch must be in either the 10k, 7k or 5k position.

Tilt Control

The Tilt control operates exactly as its name implies and produces a very gradual change in level across the musical spectrum without changing the overall subjective level. When set for $+1 -1$ there will be a gradual fall of 2dB from bass to treble with a maximum rate of change in the centre of not more than $\frac{1}{2}$ dB per octave. This absence of sudden change means that there will be no 'colouration' added to the sound. The sound will remain entirely natural but with a slight added warmth. Such a setting will be used if the recording and/or the listening room are slightly too analytical or overbright.

Conversely if both the recording environment and the listening room have reverberation falling with frequency (rather lush sounding) then $-1 +1$ (or even $-2 +2$) would be used to restore detail. In using this control the extreme bass and extreme treble should not unduly influence judgement because these are separately adjustable.

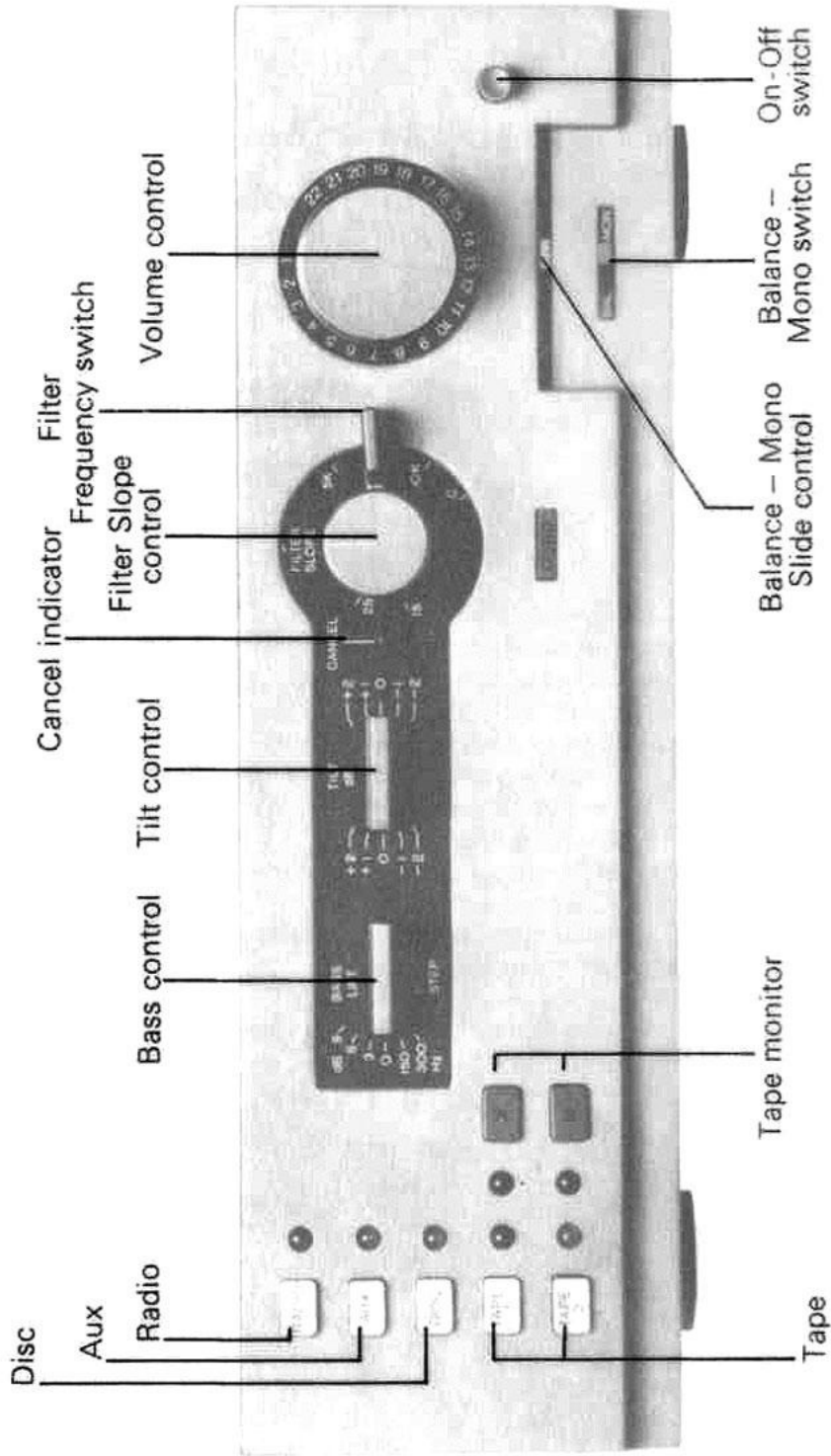

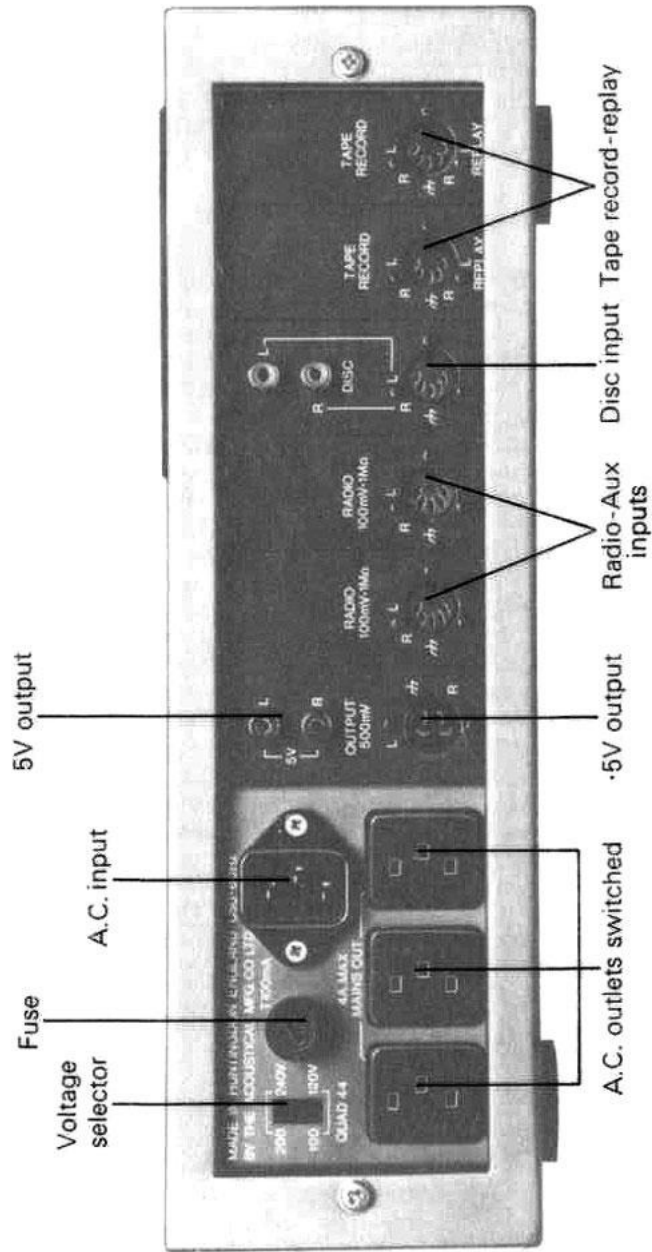

Bass Lift and Step

In the Lift position the Bass control acts as a smooth progressive boost for use with small loudspeakers of necessarily limited bass response.

In the Step mode the control acts as a step filter, producing a 5dB drop in output centred on either 150Hz or 300Hz. This will be found to be extremely useful in removing the characteristic 'honk' caused by the excitation of the room's eigentones by the loudspeakers, particularly when they have to be placed in or near a corner.

Filter

The Filter consists of two concentric controls, a switch which selects the frequency at which the filter operates, with a Cancel position which bypasses all controls except Volume and Balance to give a level response, and the Slope control which alters the rate at which the filter attenuates frequencies above the selected operating point.

Three filter frequencies are available, 5kHz, 7kHz and 10kHz, and the Slope control varies the rate of attenuation of this filter from 0dB to 25dB per octave.

For example, with the 7k position selected and the Slope control turned to 10, the output level of the Quad 44 will be 10dB down at 14kHz.

With most recordings distortion rises rapidly with increasing frequency, and at very high frequencies can have a magnitude equal to or greater than the music. The Filter affects the extreme harmonic range only and is designed to remove unwanted distortion without altering the music content of the programme. The effect of the Tilt, Bass and Filter can readily be understood from the accompanying graphs on Pages 23, 24 and 25 and the listener is encouraged to experiment with the controls using a familiar recording to become fully conversant with their scope.

Balance-Mono

The Balance-Mono control combines the functions of balance, left-right speaker switching, stereo/mono switching, and enables the input from one channel to be played through both loudspeakers.

With the switch in the Balance position, the output of the control unit is stereo (assuming a stereo input) and the control operates to adjust the balance between the two channels. It should require no alteration after initial adjustment unless the position of the loudspeakers is changed, or very rarely, when a particular recording or broadcast is misbalanced. With the Slide control fully over to either side the output from the other loudspeaker is reduced to zero.

With the switch in the Mono position, and the Slide control in the centre, the left and right inputs are added giving a monaural output from both loudspeakers. As the Slide control is moved to the right the output of the Quad 44 contains progressively more right channel information and less left until with the control in its far right position the output of both loudspeakers is right channel input only. Moving the Slide control to the left produces the converse.

Headphones

The high level output of the Quad 44 can be used to drive headphones with impedance of 600Ω or greater. Electrostatic or low impedance moving coil headphones should be connected to the speaker output of the power amplifier according to the manufacturers' instructions.

Operating Summary

Switch on the Control unit, which will also switch on the units connected to the A.C. outlets.

Check that the Balance-Mono switch is in the balance position with the Slide control central.

Press the required input button.

Adjust the Volume control to give the required output level.

Switch the Filter to 10k leaving the slope at 0 and apply bass corrections if necessary.

The Tilt and Filter controls can then be used according to the requirements of the particular programme and listening room.

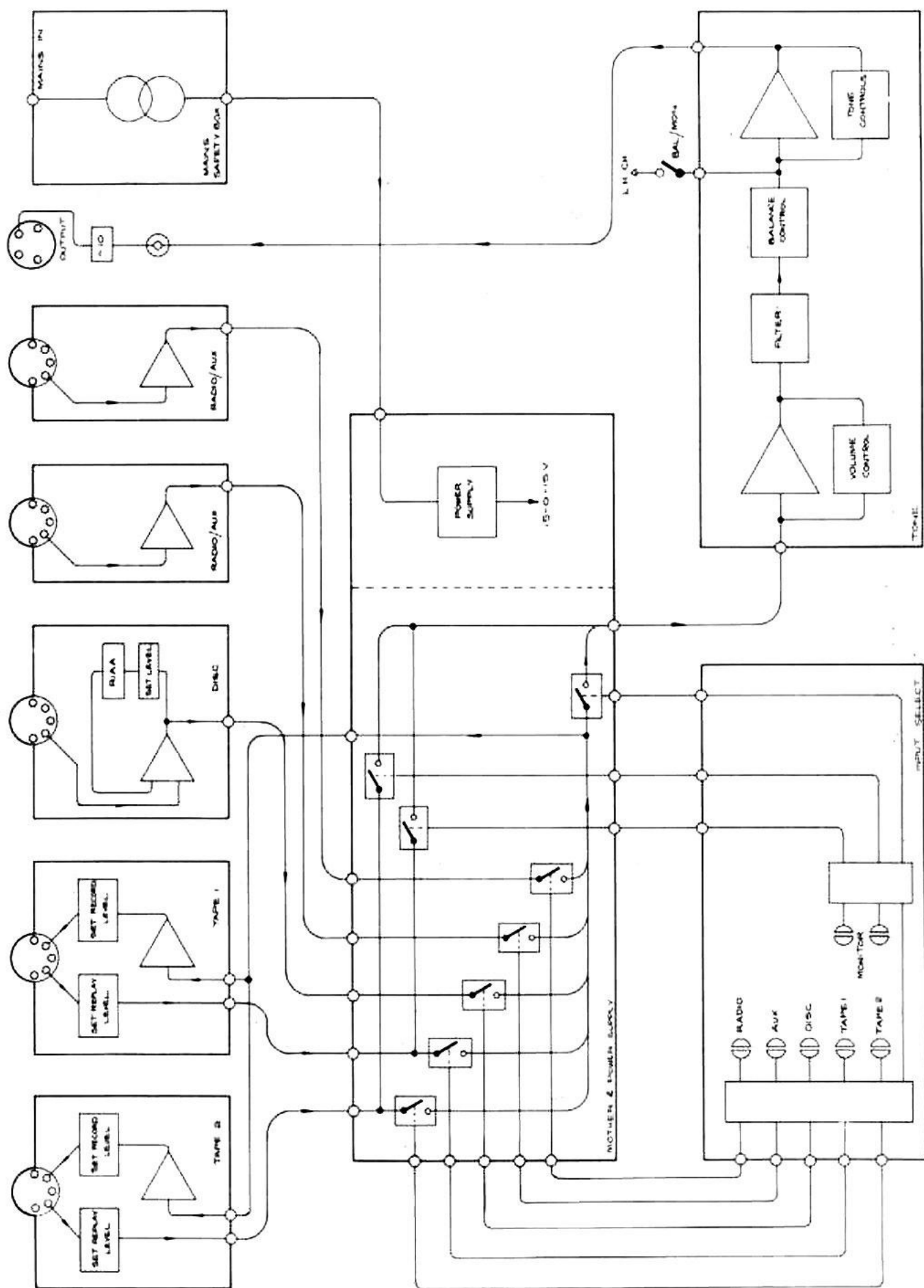

QUAD 44 BLOCK DIAGRAM

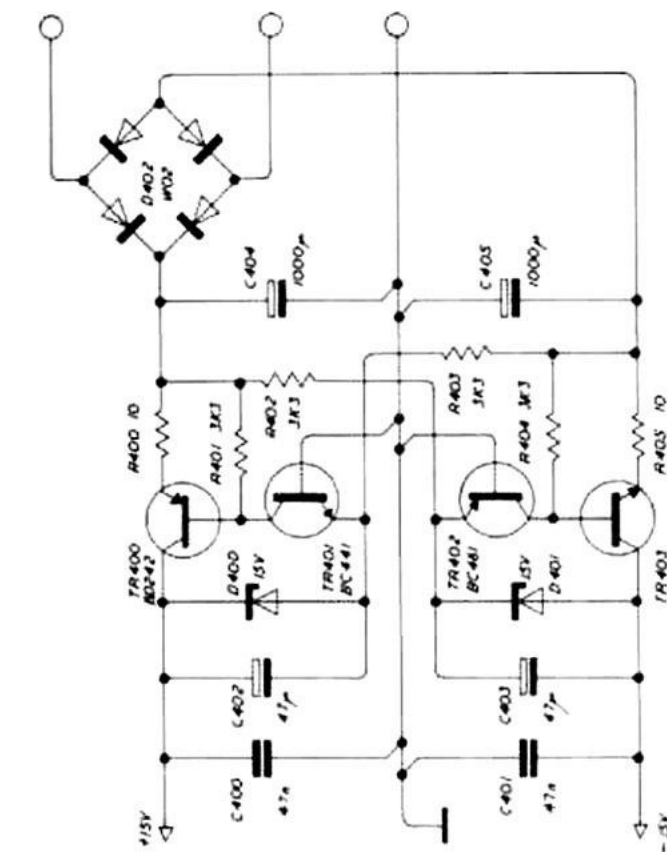
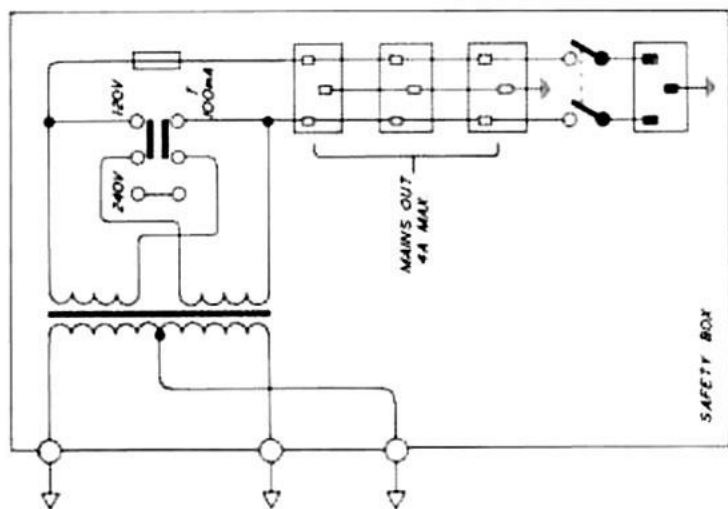

QUAD 44 MOTHER BOARD

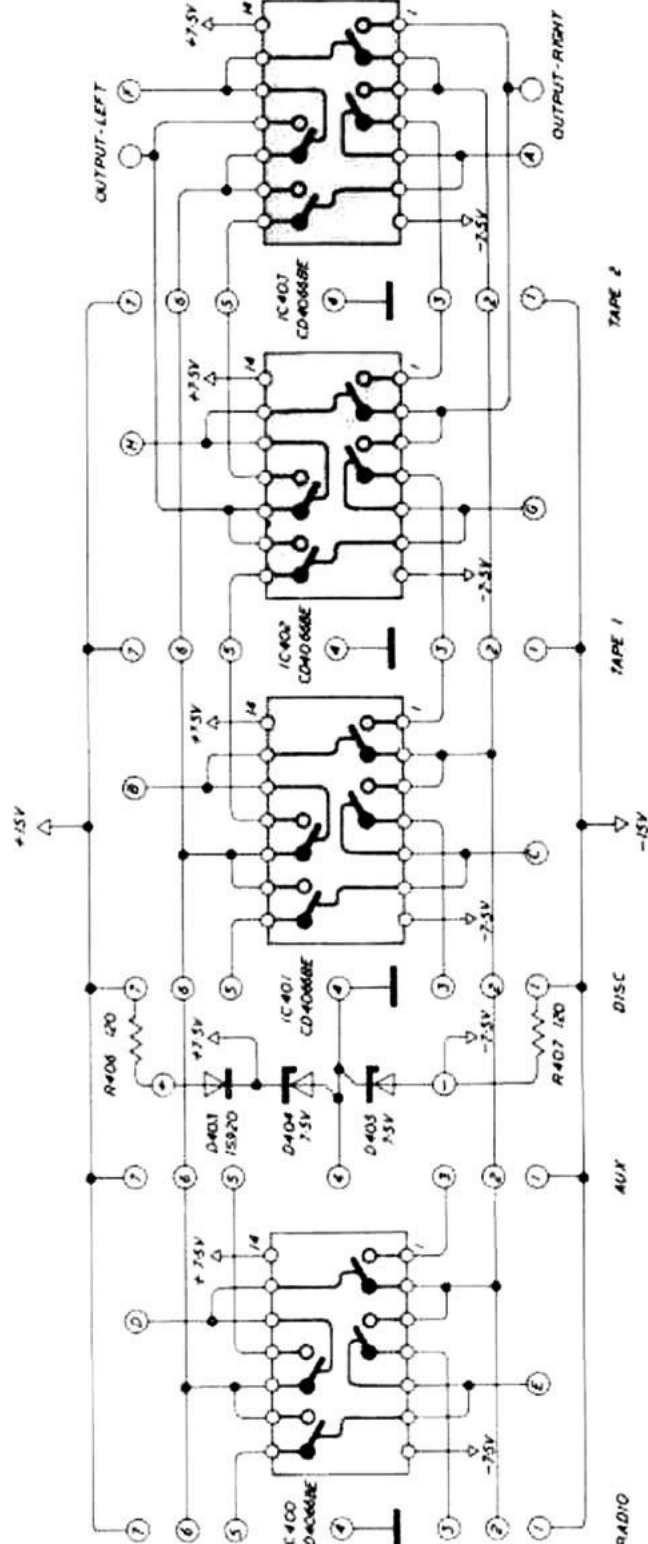

M12436

QTY	REF NO	STOCK NO	DESCRIPTION
4	IC400 IC401 IC402 IC403		INTEGRATED CIRCUIT CD4068RE
1	TR400		TRANSISTOR 80242
1	TR401		TRANSISTOR 8C441
1	TR402		TRANSISTOR 8C461
1	TR403		TRANSISTOR 80241
2	D400 D401		ZENER DIODE BZY88C 15V
2	D404 D405		ZENER DIODE BZY88C 7.5V
1	D403		DIODE 15920
1	D402		RECTIFIER W02
4	R401 R402 R403 R404	244/D	RESISTOR 3K3 ± 5%
2	R400 R405	320/B	RESISTOR 10 ± 5%
2	R406 R407	300/C	RESISTOR 120 ± 5%
2	C400 C401	500/I	CAPACITOR 47 n
2	C402 C403	480/A	CAPACITOR 47µ 10V
2	C404 C405	450/C	CAPACITOR 1000µ 25V
1			PRINTED BOARD TO DRG M12436

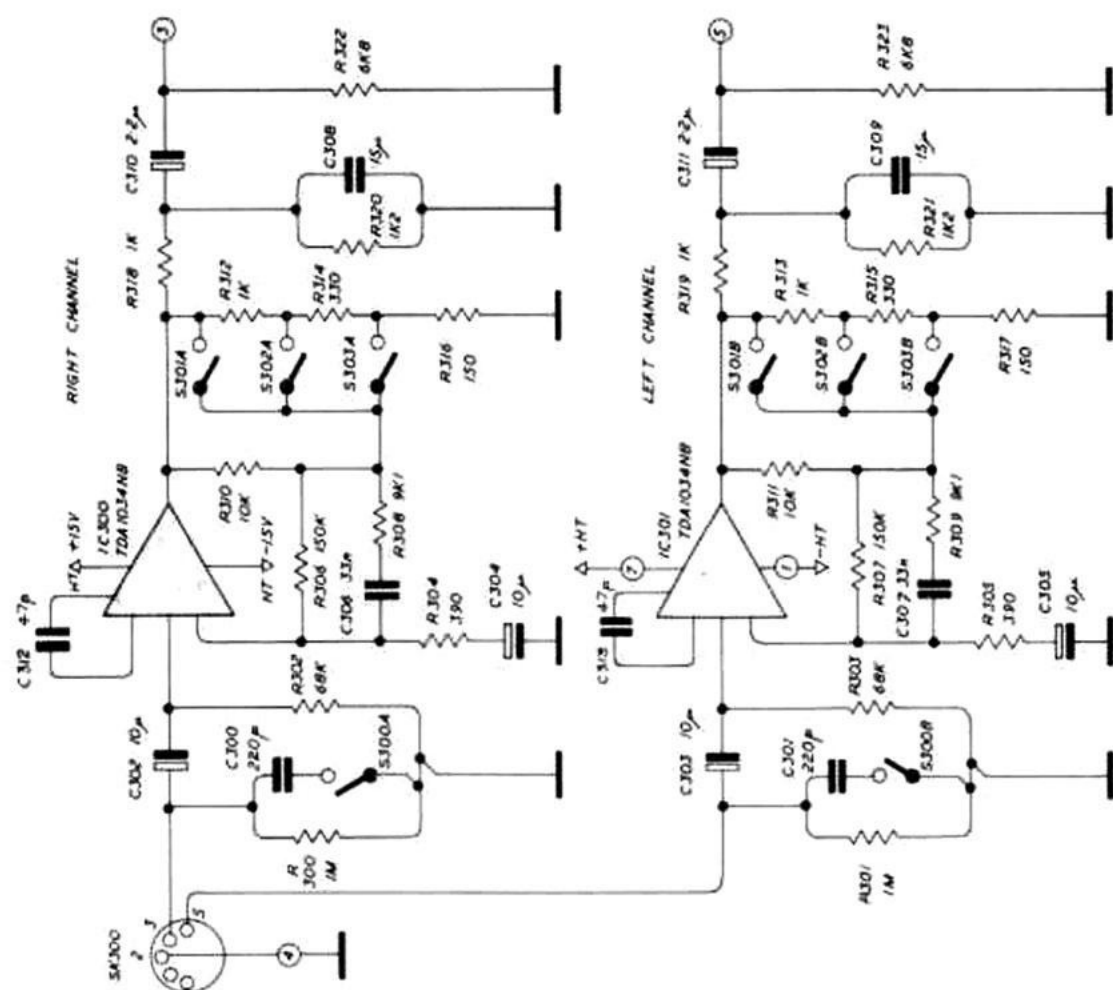

QTY	REF NO	STOCK NO	DESCRIPTION
2	IC300, IC301	165/C	INTEGRATED CIRCUIT TDA1034NB
2	R300, R301	205/C	RESISTOR 1M ±5%
2	R302, R303	205/C	RESISTOR 68K ±5%
2	R304, R305	215/B	RESISTOR 390 ±2%
2	R306, R307	193/C	RESISTOR 150K ±2%
2	R308, R309	231/A	RESISTOR 9K1 ±2%
2	R310, R311	230/G	RESISTOR 10K ±5%
4	R312, R313 R318, R319	258/G	RESISTOR 1K ±2%
2	R314, R315	280/E	RESISTOR 330 ±2%
2	R316, R317	295/C	RESISTOR 150 ±2%
2	R320, R321	257/C	RESISTOR 1K2 ±2%
2	R322, R323	235/E	RESISTOR 6K8 ±2%
2	C300, C301	526/B	CAPACITOR 220 p
4	C302, C303 C304, C305	474/C	CAPACITOR 0.1 μ 16V
2	C306, C307	502/B	CAPACITOR 33 p
2	C308, C309	494/H	CAPACITOR 15 μ ±5%
2	C310, C311	483/B	CAPACITOR 2.2 μ 16V
2	C312, C313	534/C	CAPACITOR 47 p
1	S300	672/B	5 PIN DIN SOCKET
1	S300-S303		DIL SWITCH DYS-405
5	J1, J2, J3, J4, J5		BOARD SOCKET
1			PRINTED BOARD TO DRG MI2515

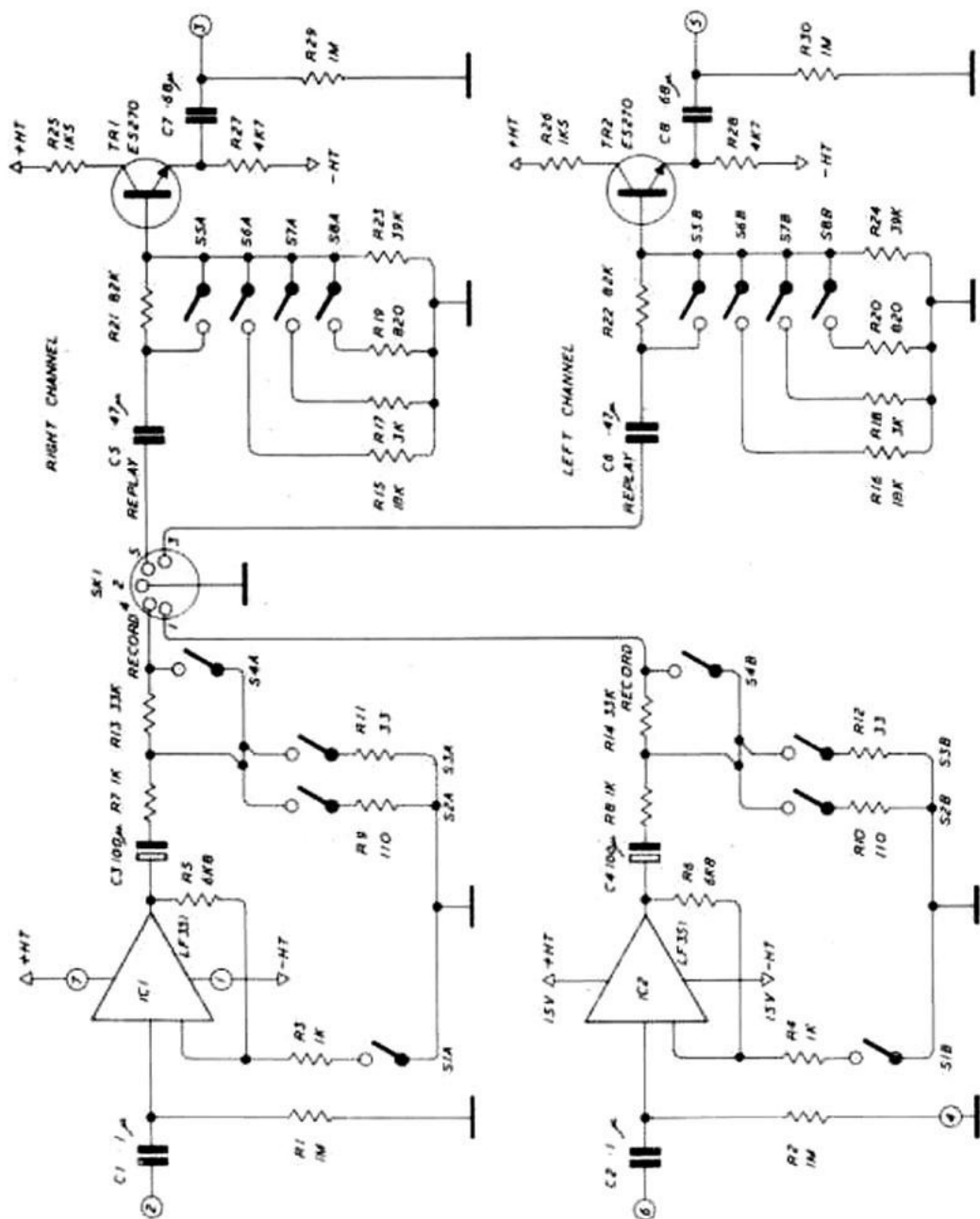

QUAD 44 TAPE INPUT/OUTPUT

QTY	REF NO	STOCK NO	DESCRIPTION
2	TR1, TR2		TRANSISTOR ES270
2	IC1, IC2		INTEGRATED CIRCUIT LF351
2	S1 — SB		DIL SWITCH DYS-40S
4	R1, R2, R29, R30	16S/C	RESISTOR 1M ±5%
4	R3, R4, R7, R8	250/E	RESISTOR 1K ±3%
2	R5, R6	235/D	RESISTOR 4K8 ±5%
2	R9, R10	30/JA	RESISTOR 110 ±3%
2	R11, R12	3-4/B	RESISTOR 33 ±5%
2	R13, R14	209/E	RESISTOR 33K ±5%
2	R15, R16	220/C	RESISTOR 18K ±5%
2	R17, R18	245/A	RESISTOR 3K ±5%
2	R19, R20	280/C	RESISTOR 820 ±5%
2	R21, R22	203/C	RESISTOR 82K ±5%
2	R23, R24	208/M	RESISTOR 39K ±5%
2	R25, R26	255/H	RESISTOR 1K5 ±5%
2	R27, R28	240/H	RESISTOR 4K7 ±5%
2	C1, C2	495/I	CAPACITOR 1μ 100V
2	C3, C4	455/B	CAPACITOR 100μ 3V
2	C5, C6	492/B	CAPACITOR 47μ 100V
2	C7, C8	488/C	CAPACITOR 68μ 100V
1	SK1	672/B	5 PIN DIN SOCKET
1			PRINTED BOARD TO DRG M12946
7	1 — 7		BOARD SOCKET AMP R1863-4

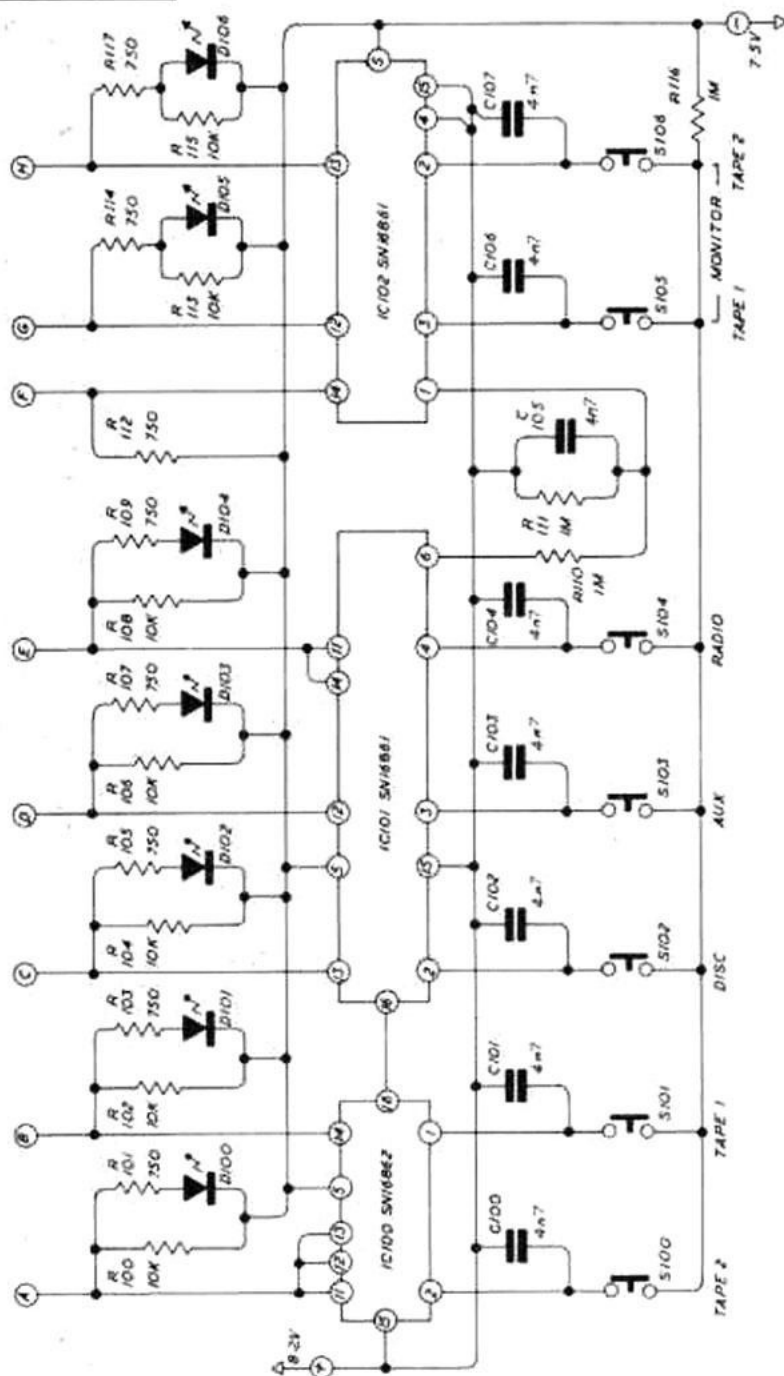
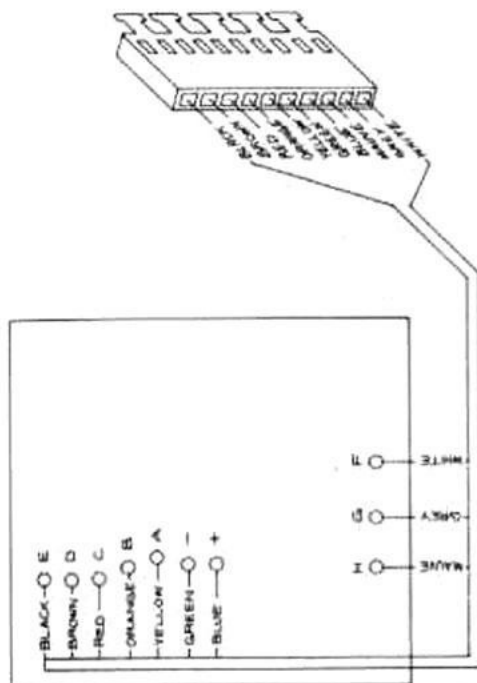

QTY	REF No	STOCK No	DESCRIPTION
7	R100, R102 R104, R106, R108 R113 R115	2310/G	RESISTOR 10K ± 5%
8	R101, R103, R105 R107, R109, R112 R114 R117	2502/F	RESISTOR 250 ± 5%
3	R110, R111, R116	165/C	RESISTOR 1M ± 3%
8	C100 - C107	512/B	CAPACITOR 4n7
5	D100 - D104		LED GREEN
2	D105 D106		LED RED
7	S100 - S106		SWITCH D6
1	IC100		INTEGRATED CIRCUIT SN1862
2	IC101 IC102		INTEGRATED CIRCUIT SN1861
1			PRINTED WIRING MASTER DRG MI2428

QUAD 44 INPUT SELECTOR

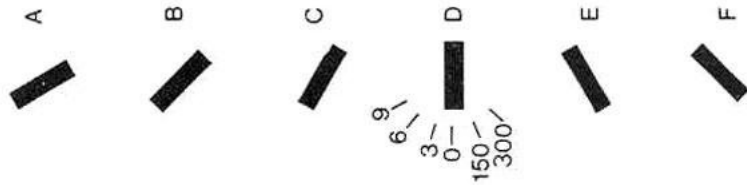
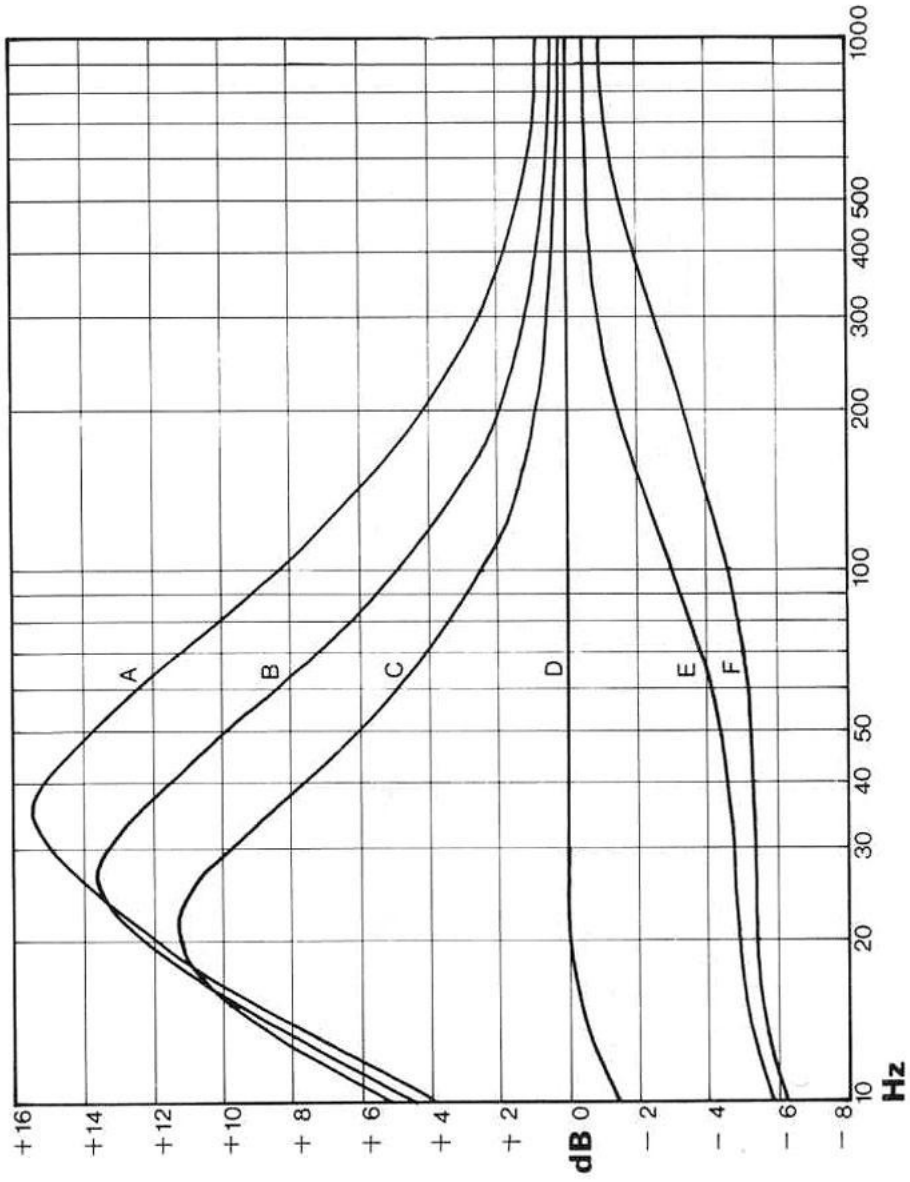

BASS CONTROL. LIFT & STEP

TILT CONTROL

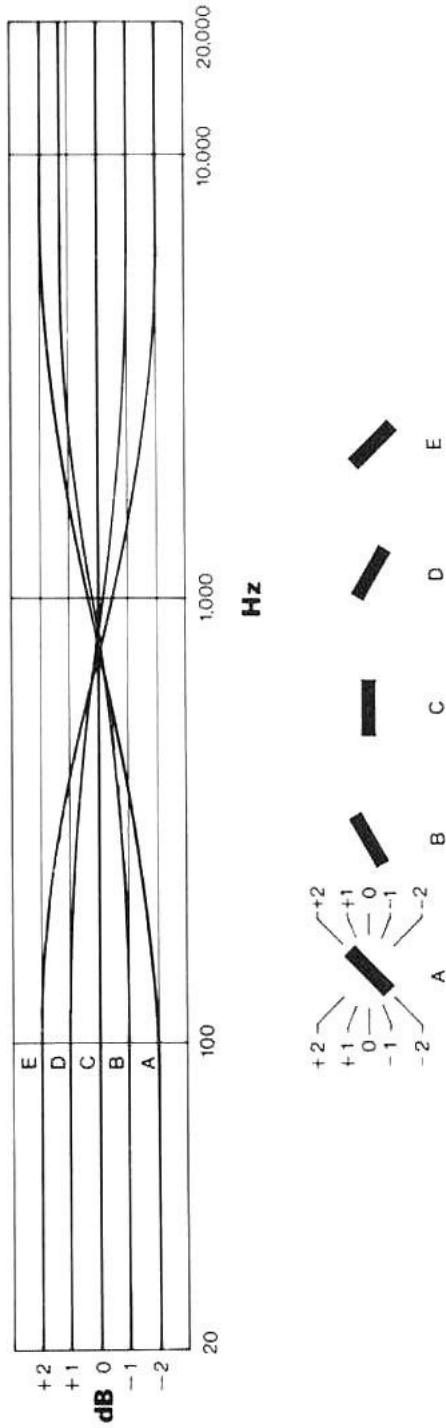

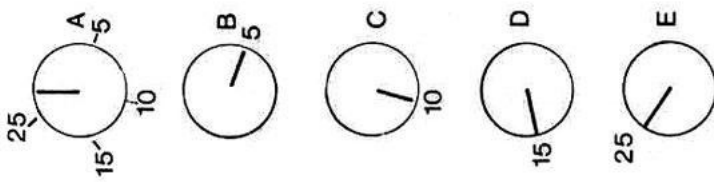
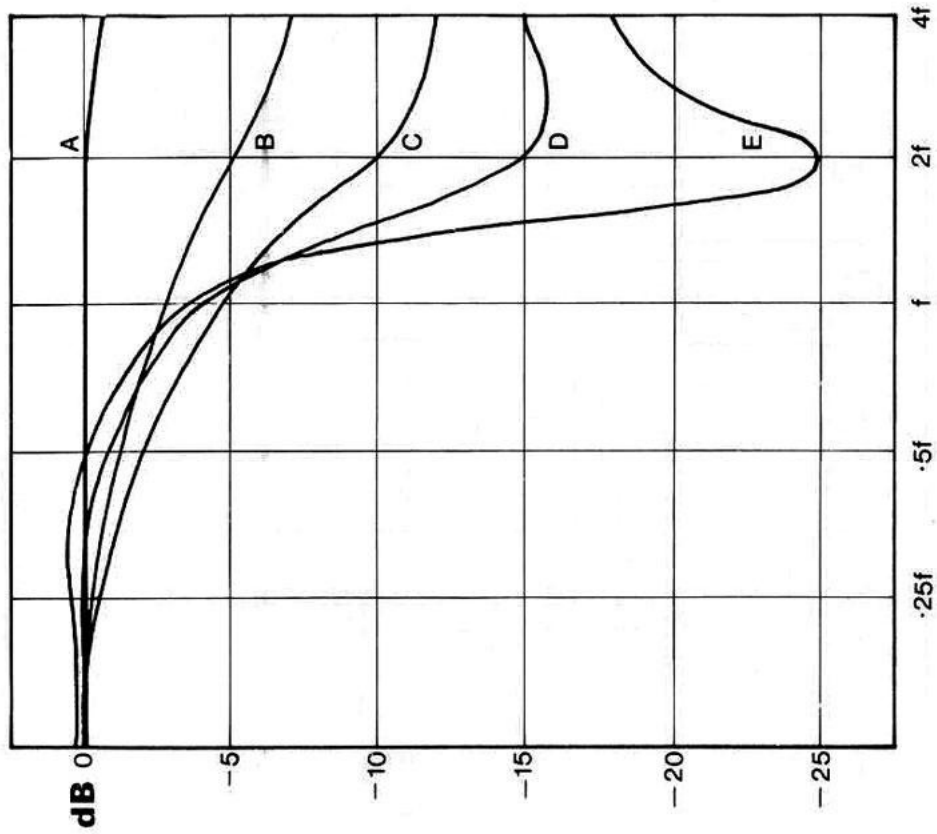

FILTER SLOPE

QUAD 44

CONTROL UNIT SPECIFICATION

NOTE: Figures refer to 5V output for convenience. All voltages quoted are rms.

Distortion Worst case, any input, -05%
Typically, any input, -02%
both at 30–10,000Hz

Residual Noise 'A' weighting. Volume control set minimum -104dB

Frequency Response Any input except Disc +0 dB 30–20,000Hz
Any output -1 dB 30–20,000Hz
Disc ± 5 dB IEC 98-4 30–20,000Hz

Tilt & Bass see curves.

Filters see curves.

Interchannel Balance ± 5 dB with volume control varied from maximum to -60dB

Crosstalk Replay/record typically better than 70dB
Interchannel better than 50dB
Both 30–10,000Hz

Power Input 100–130 or 200–250V 50–60Hz.

Weight 4 Kg.

Dimensions Width 321 mm
Height 103 mm
Depth 207 mm

OUTPUTS

To	Output Level	Source Impedance
Tape Recorder	3mV	32 Ω
	10mV	100 Ω
	24mV	32 Ω
	100mV	1k
	0dBm (775mV)	1k
		} or 33k
Power Amplifier	0-5V	1k
	5V	75 Ω

INPUTS

Source	Input Sensitivity for full Output	Maximum Input	Load Impedance	Signal to Noise 'A' weighted Input loaded
Disc	1mV	35mV	47k Ω	-63dB
	3mV	100mV	or	-72dB
	10mV	300mV	47k Ω /180pF	-82dB
Radio and Aux.	100mV	5V	1M Ω	-86dB
Tape Replay	100mV	5V	39k Ω	-86dB
	300mV	15V	121k Ω	
	0dBm (775mV)	40V	94k Ω	
	3V	100V	85k Ω	
	10V	100V	82k Ω	