



# QUAD

## SERVICE MANUAL

### MODEL QUAD 99 PRE-AMPLIFIER

QUAD 99 PRE-AMPLIFIER

#### 1. SPECIFICATIONS

<b>Aux. &amp; Tape Inputs</b>	
Sensitivity	100,300 or 775mV
Signal to Noise Ratio	>97dB(A) ref 775mV
Distortion	<0.002%
<b>Phono Inputs MM(MC)</b>	
Sensitivity	1,3 or 7.75mV (100,300 or 775uV)
Signal to Noise Ratio	78dB(A) ref 7.75mV (775uV)
Distortion	<0.05% (0.01%)
<b>Pre Amp Output</b>	
Level	775mV (3.3 volts maximum)
Source Impedance	100 Ohms
<b>AMPBUS Output</b>	
Level	2 volts (8 volts maximum)
Source Impedance	20 Ohms
<b>Tape Output</b>	
Level	100,300,775mV (10 volts maximum)
Source Impedance	330 Ohms
All inputs except MM & MC	10Hz to 20kHz    +0dB/-0.3dB
	3Hz to 56kHz    +0dB/-3dB
MM & MC inputs	20Hz to 20kHz    +/-0.5dB
	7Hz to 53kHz    +0.5dB/-3dB
<b>Dimensions</b>	70mm × 321mm × 310mm(H × W × D)
<b>Weight</b>	4.42kgs

The following abbreviations are used:

**RIAA**    Recording Industry Association of America

**MM**      Moving magnet cartridge

**MC**      Moving coil cartridge

## 2. ASSEMBLY SKETCH

QUAD 99 PRE-AMPLIFIER

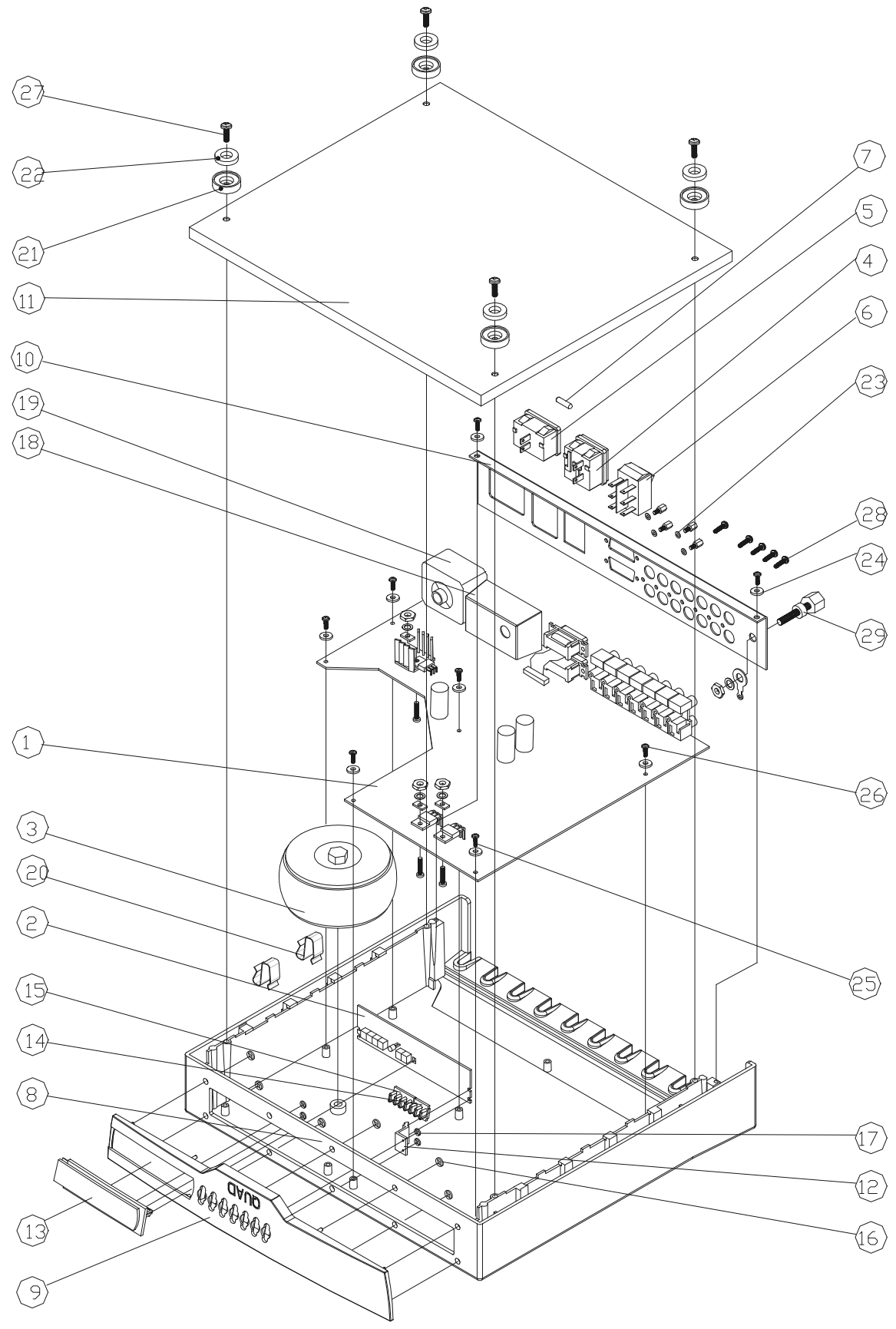

### 3. ASSEMBLY PARTS LIST

QUAD 99 PRE-AMPLIFIER

R/P	P/N	PART NAME	DESCRIPTION	QUA
1	088-1118001000	AMPLIFIER P.C.B		1
2	088-1118003500	DISPLAY P.C.B		1
3	022-2000802060	TRANSFORMER		1
4	044-1800000000	SOCKET		1
5	044-1500000000	SOCKET		1
6	041-2191000000	SWITCH		1
7	031-4200504121	FUSE		1
8	302-1115000001	TOP COVER		1
9	300-1178000001	FRONT PANEL		1
10	301-1118000001	REAR PANEL		1
11	303-1115000001	BOTTOM COVER		1
12	205-1117000001	PCB SUPPORT		1
13	273-1116000001	F/PANEL WINDOW		1
14	211-1176000001	3 BUTTON PAD		1
15	211-1177000001	4 BUTTON PAD		1
16	384-0850211100	CLAW RING	8.5*2.1	8
17	384-0630161100	CLAW RING	6.3*1.6	4
18	278-1175000120	POWER BOX		1
19	391-1178000001	SOCKET BUSH	AM-FIECB/PRE	1
20	318-1175000001	IC CLIP		2
21	226-0180450511	FOOT		4
22	231-2016006300	SELF-ADHESIVE FOOT		4
23	521-3005060500A	WASHER	M3*5*0.6Cu	11
24	521-4009060300A	WASHER	M4*9*0.6Zn	2
25	537-2501060801A	SCREW	MP(+)2.5*6 BZn D	2
26	533-3001060301A	SCREW	MT(+)3*6 Zn D	5
27	536-4001060301A	SCREW	MT(+)4*6 Zn D	6
28	526-3012090811A	SCREW	SB(+)3*9 DC H BZn	5
29	046-3100000000	TEAMINAL		1

# 4. SCHEMATIC DIAGRAM

## QUAD 99 PRE-AMPLIFIER

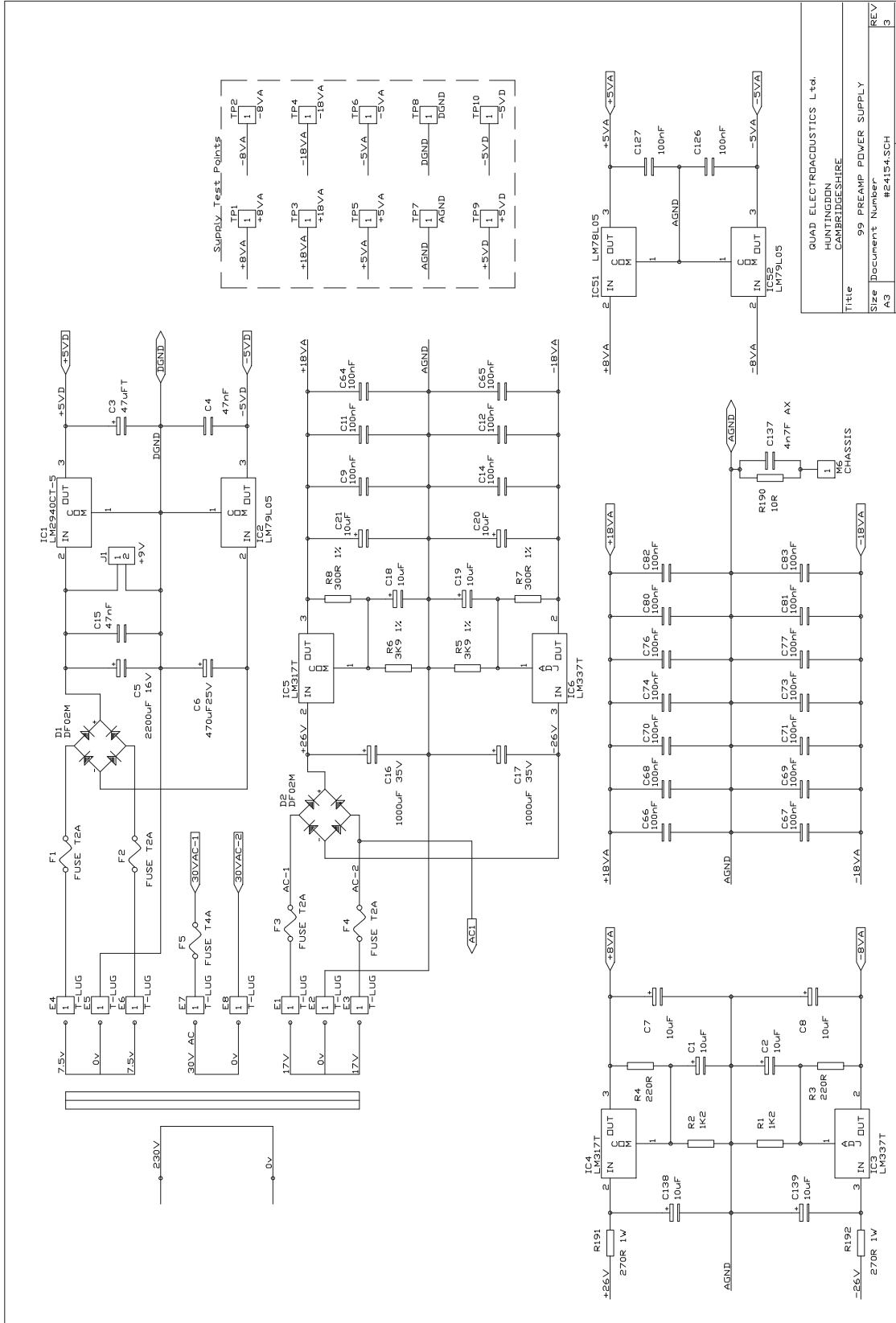

Title	QUAD ELECTROACOUSTICS Ltd. HUNTINGDON CAMBRIDGESHIRE
Size	99 PREAMP POWER SUPPLY
Document Number	#24154-SCH
REV	3
Date	August 24, 2004
Sheet	2 of 9

# 4. SCHEMATIC DIAGRAM

## QUAD 99 PRE-AMPLIFIER

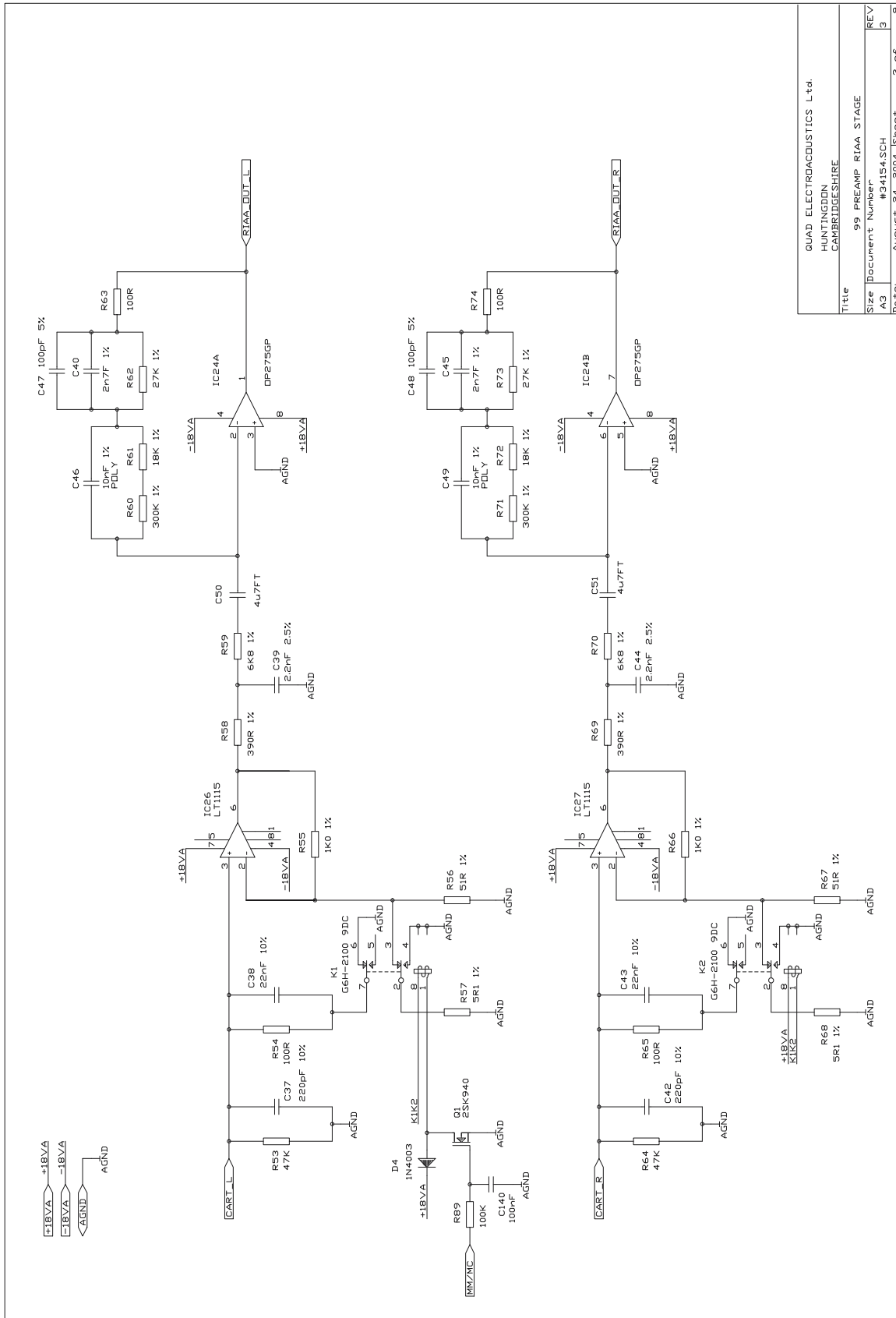

QUAD ELECTROACOUSTICS L.td.	
HUNTINGDON CAMBRIDGESHIRE	
Title	99 PREAMP R1AA STAGE
Size	Document Number
A3	#24154 SCH
Date	August 24, 2004 Street 3 of 3

# 4. SCHEMATIC DIAGRAM

**QUAD 99 PRE-AMPLIFIER**

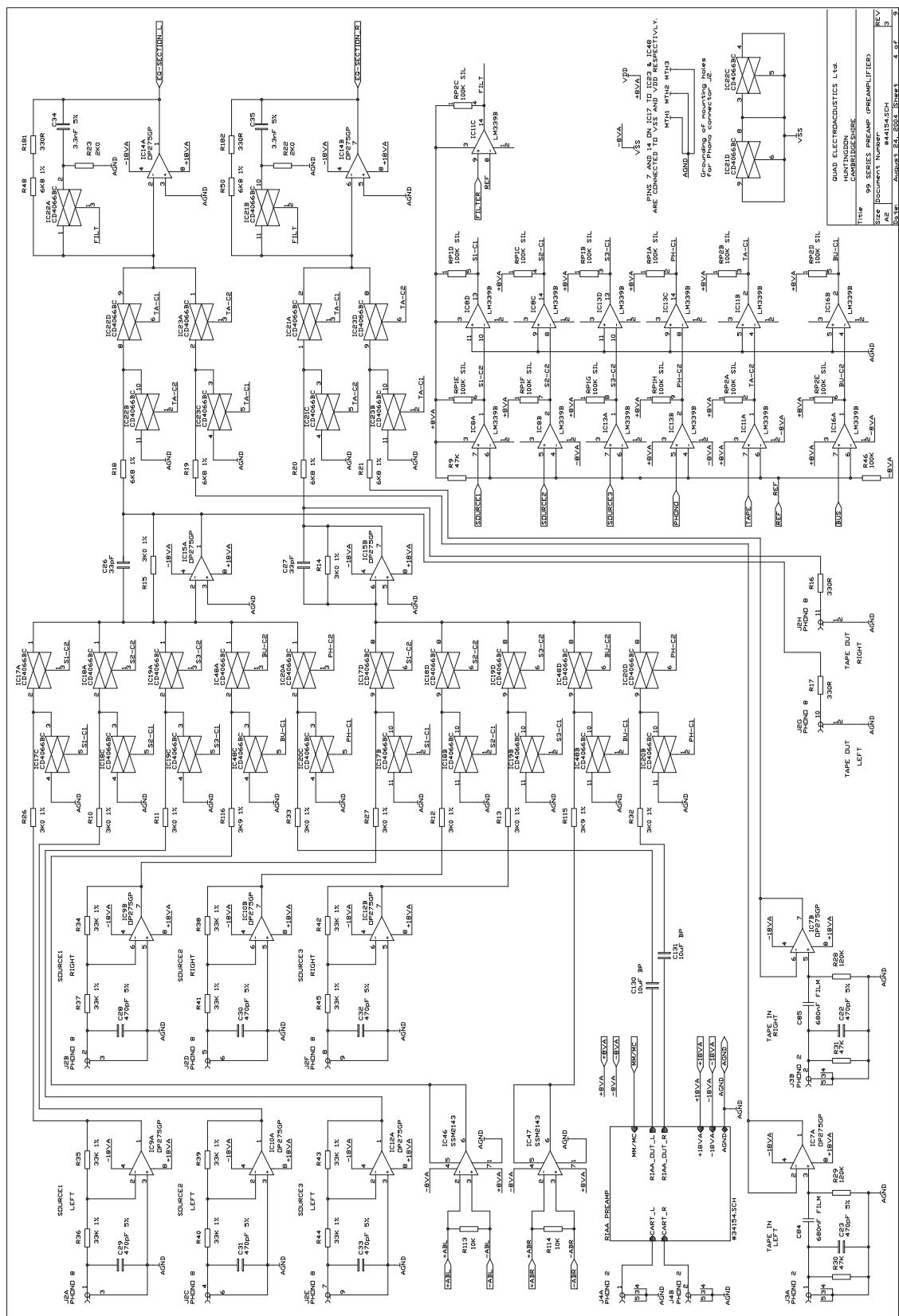



# 4. SCHEMATIC DIAGRAM

## QUAD 99 PRE-AMPLIFIER

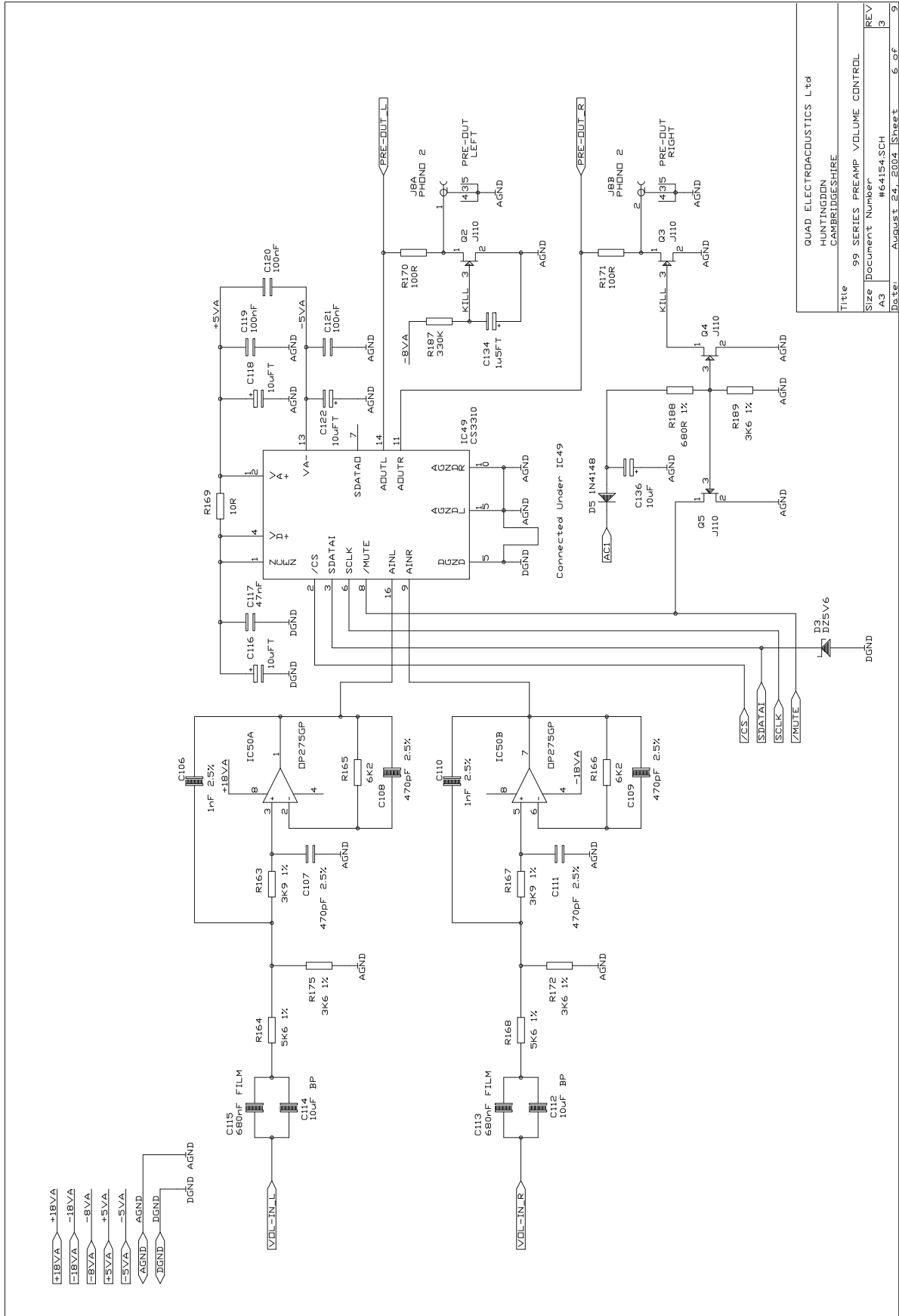

QUAD ELECTROACOUSTICS Ltd	
HUNTINGDON CAMBRIDGESHIRE	
Title	99 SERIES PREAMP VOLUME CONTROL
Size	Document Number #64154.SCH
REV	3
Date	August 23, 2003 Sheet 6 of 9



# 4. SCHEMATIC DIAGRAM

## QUAD 99 PRE-AMPLIFIER

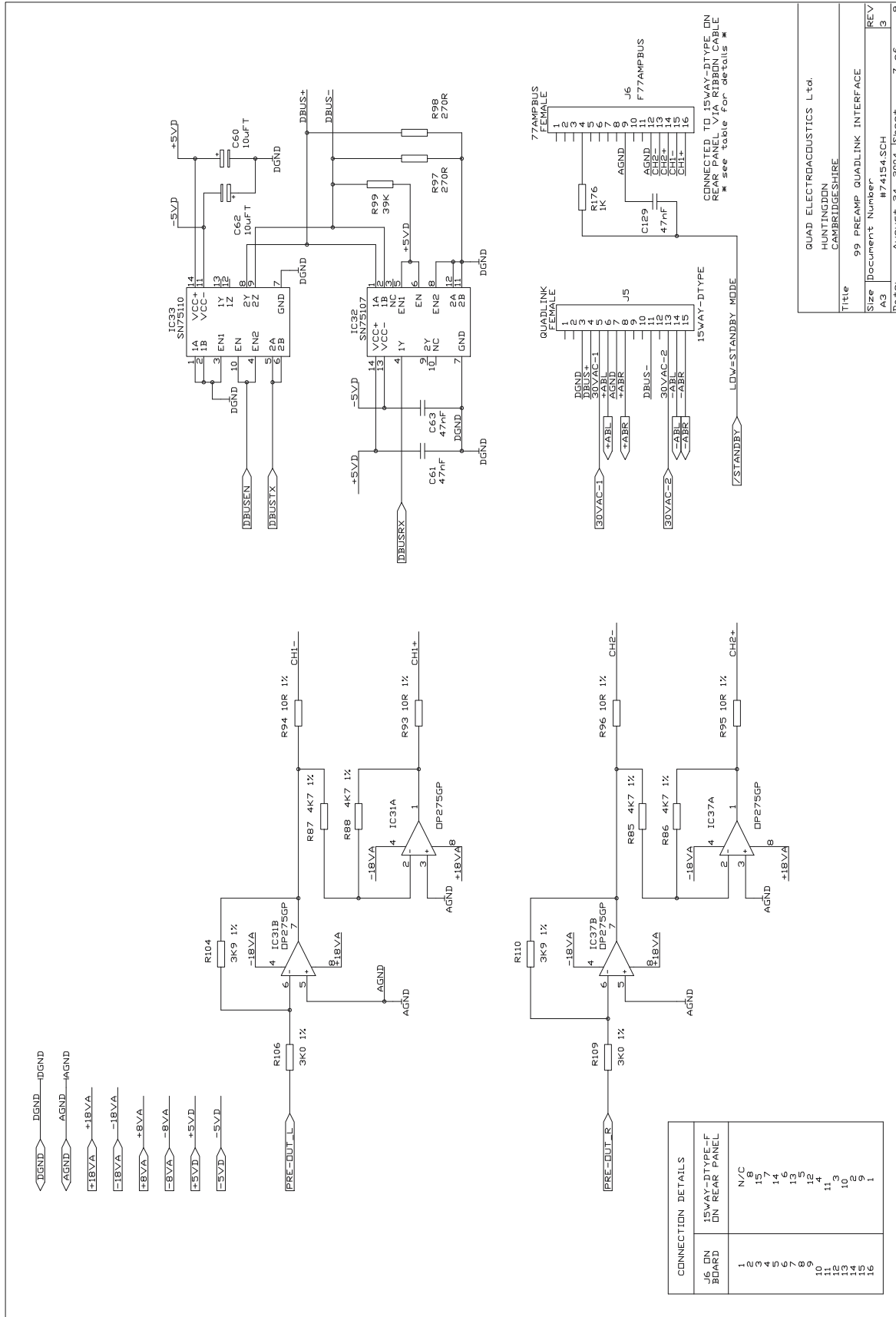

# 4. SCHEMATIC DIAGRAM

## QUAD 99 PRE-AMPLIFIER

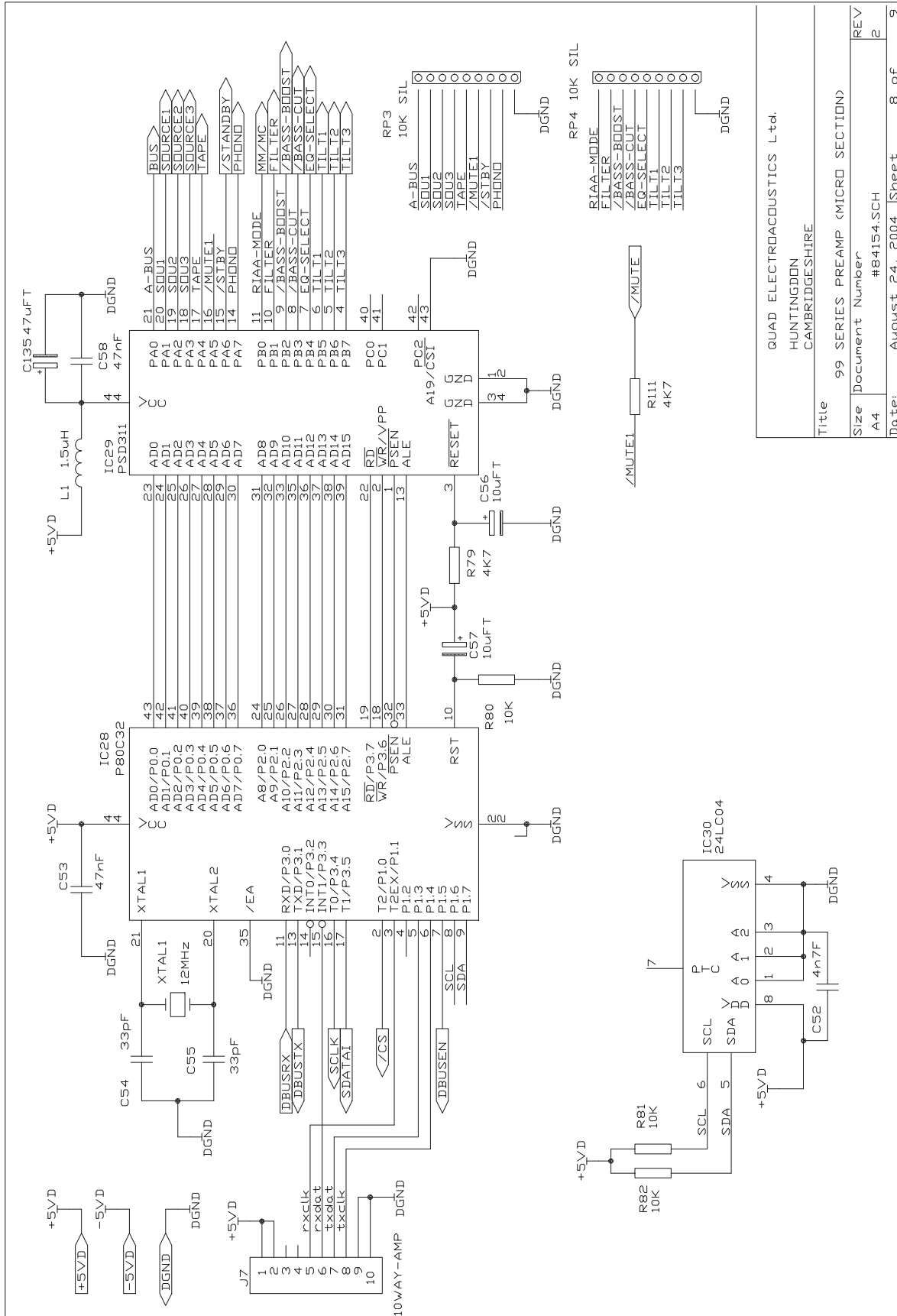

QUAD ELECTROACOUSTICS Ltd.	
HUNTINGDON CAMBRIDGESHIRE	
Title	99 SERIES PREAMP (MICRO SECTION)
Size	A4
Document Number	#84154.SCH
Date:	August 24, 2004
Sheet	8 of 9
REV	2

QUAD 99 PRE-AMPLIFIER

# 4. SCHEMATIC DIAGRAM

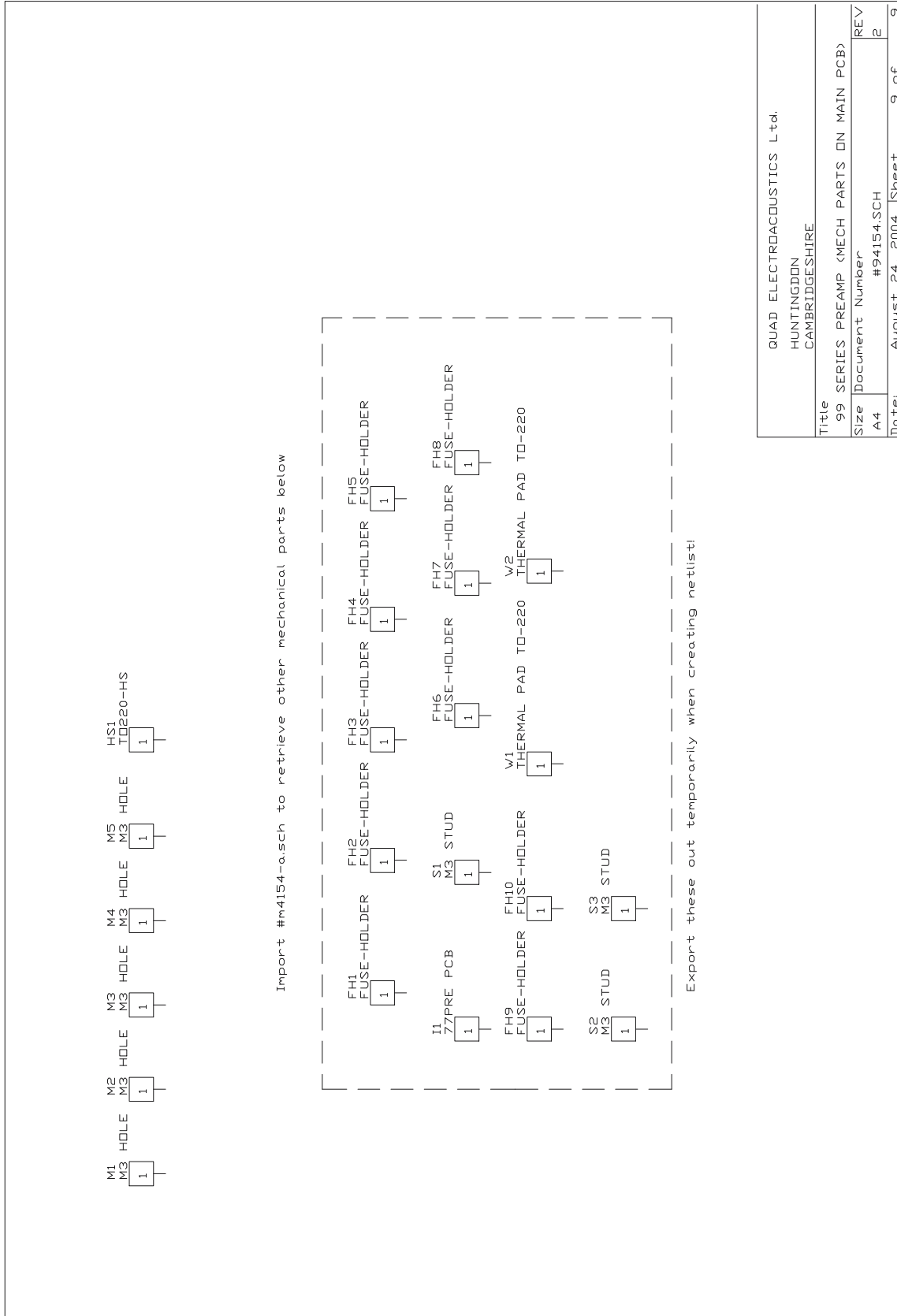

# 4. SCHEMATIC DIAGRAM

## QUAD 99 PRE-AMPLIFIER

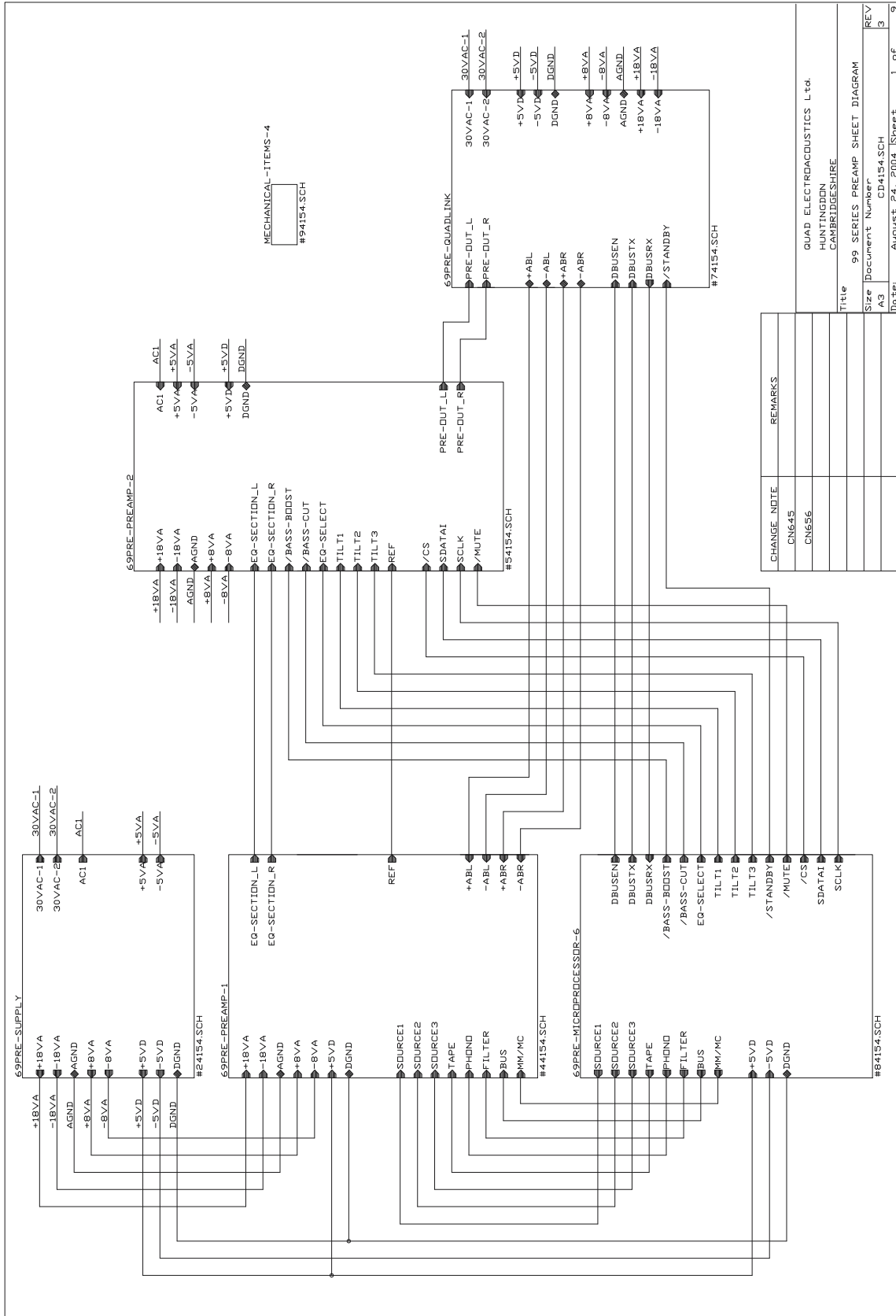

CHANGE NOTE	REMARKS
CN645	
CN656	

QUAD ELECTROACOUSTICS LTD.	
HUNTINGDON	
CAMBRIDGESHIRE	
Title	99 SERIES PREAMP SHEET DIAGRAM
Size	Document Number
A3	CD4154.SCH
REV	3
Date	August 24, 2004
Sheet	1 of 9

# 4. SCHEMATIC DIAGRAM

## QUAD 99 PRE-AMPLIFIER

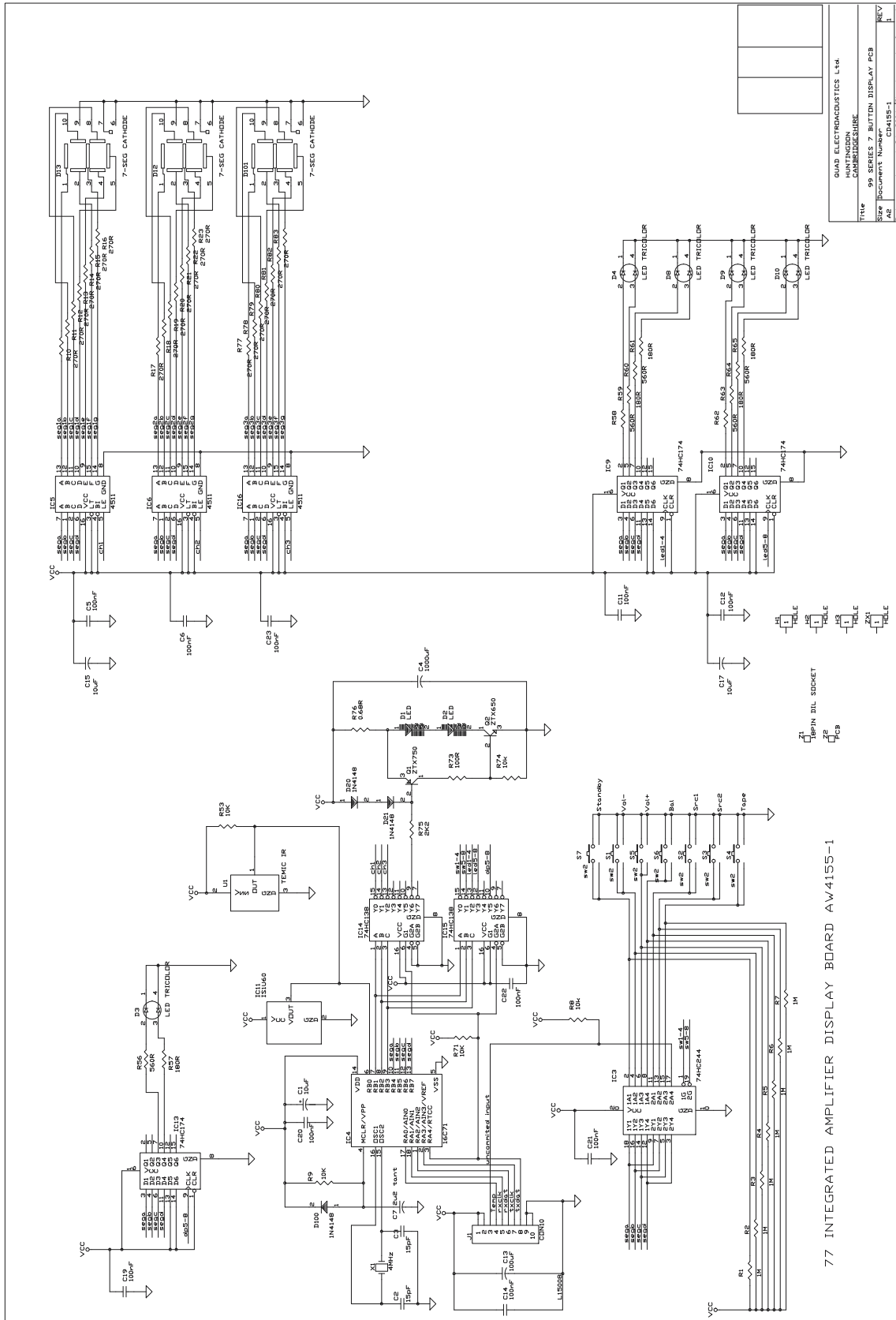

77 INTEGRATED AMPLIFIER DISPLAY BOARD AW4155-1

QUAD ELECTRODYNAMICS, L.A.  
 HUNTINGTON  
 CALIFORNIA  
 99 SERIES 7 BUTTON DISPLAY PCB  
 Part Document Number: AW 4155-1  
 Rev: August 82, Rev. 3/83

## 5. ELECTRONIC PARTS LIST

QUAD 99 PRE-AMPLIFIER

R/P	P/N	PART NAME	DESCRIPTION	REF/N
1	053-1118001610	P.C.B		PCB1
2	001-5109205010	RESISTOR	5R1 1/4W1%	R57,68
3	001-1000306050	RESISTOR	10ohm1/2W J	R169,190
4	001-1000205010	RESISTOR	12ohm1/4W 1%	R93~96
5	001-5100205010	RESISTOR	51R1/4W1%	R56,67
6	001-1001205010	RESISTOR	100ohm1/4W F	R54,63,65,74,170,171
7	001-2201205010	RESISTOR	220ohm1/4W F	R3,4
8	001-2701205010	RESISTOR	270ohm1/4W F	R97,98
9	001-2701307050	RESISTOR	270ohm1W J	R191,192
10	001-3001205010	RESISTOR	300ohm1/4W F	R7,8
11	001-3301205010	RESISTOR	330ohm1/4W F	R16,17,181,182
12	001-3901205010	RESISTOR	390ohm1/4W F	R58,69
13	001-6801205010	RESISTOR	680ohm1/4W F	R188
14	001-9101205010	RESISTOR	910R1/4W1%	R122~127,141~146
15	001-1002205010	RESISTOR	1K1/4W F	R55,66,176
16	001-1202205010	RESISTOR	1.2K1/4W F	R1,2
17	001-1302205010	RESISTOR	1K3 1/4W F	R120,121,138,139
18	001-2002205010	RESISTOR	2K 1/4W F	R22,23
19	001-3002205010	RESISTOR	3K1/4W F	R10~15,R26,27,32,33,106,109
20	001-3602205010	RESISTOR	3K6 1/4W1%	R172,175,189
21	001-3902205010	RESISTOR	3.9K1/4W F	R5,6,115,116,163,167
22	001-4702205010	RESISTOR	4.7K 1/4W F	R85~88,79,111
23	001-5602205010	RESISTOR	5.6K-1/4W-F	R148,160,164,168
24	001-6202205010	RESISTOR	6K2 1/4W1%	R165,166
25	001-6802205010	RESISTOR	6.8K1/4W F	R18~21,48,50,59,70,104,110,117,130,134,135
26	001-8202205010	RESISTOR	8.2K1/4W F	R147,149,151,159,161,162,183~186
27	001-1003205010	RESISTOR	10K1/4W F	R80~82,113,114
28	001-1103205010	RESISTOR	11K1/4W F	R150,152~158
29	001-1203205010	RESISTOR	12K1/4W F	R119,128,132,137

## 5. ELECTRONIC PARTS LIST

QUAD 99 PRE-AMPLIFIER

30	001-1303205010	RESISTOR	13K1/4W1%	R118,129,133,136
31	001-1803205010	RESISTOR	18K1/4W F	R61,72
32	001-2703205010	RESISTOR	27K1/4W F	R62,73
33	001-3303205010	RESISTOR	33K1/4W F	R34~45
34	001-3903205010	RESISTOR	39K1/4W F	R99
35	001-4703205010	RESISTOR	47K 1/4W F	R9,30,31,53,64,179
36	001-1004205010	RESISTOR	100K1/4W F	R46,89,180
37	001-1204205010	RESISTOR	120K1/4W F	R28,29
38	001-3004205010	RESISTOR	300K1/4W1%	R60,71
39	001-3304205010	RESISTOR	330K1/4W F	R187
40	001-1005205010	RESISTOR	1M1/4W F	R131,140
41	003-1004092202	RESISTORS	RA1/8W9A100K2%	RP1,2,5
42	003-1003092202	RESISTORS	RA1/8W9A10K G	RP3,4
43	008-3300010008	CAPACITOR	33pF100V2%	C26,27,54,55
44	008-6800010008	CAPACITOR	68pF100V2%	C90,101
45	013-1010310507	CAPACITOR	100pF 100V 5%	C47,48
46	013-2210220507	CAPACITOR	220pF 63V 10%	C37,42
47	016-2710802201	CAPACITOR	270pF63V5%	C132,133
48	016-4710832201	CAPACITOR	470PF 63V 2.5%	C107,108,109,111
49	016-4710802201	CAPACITOR	470pF 63V 5%	C22,23,28~33
50	016-1020832201	CAPACITOR	1nF63V2.5%	C106,110
51	016-2220832201	CAPACITOR	2.2nF63V2.5%	C39,44
52	016-2720852201	CAPACITOR	2.7nF63V1%	C40,45
53	016-3320802201	CAPACITOR	3.3nF63V5%	C34,35
54	009-4721008110	CAPACITOR	4.7nF 100V20%	C52
55	009-4721008000	CAPACITOR	4.7nF 100V20%	C137
56	014-1030211028	CAPACITOR	10uF63V10%	C86,88,99,102
57	014-2230211028	CAPACITOR	22nF63V10%	C38,43,92,96
58	014-3330200028	CAPACITOR	33nF63V5%	C87,89,100,103
59	014-4740211028	CAPACITOR	470nF63V10%	
60	009-4731009110	CAPACITOR	47nF100V-20%+80%	C4,15,53,58,61,63,117,129

## 5. ELECTRONIC PARTS LIST

QUAD 99 PRE-AMPLIFIER

61	013-1030200506	CAPACITOR	PS 10nF63V1%	C46,49
62	014-1040211028	CAPACITOR	100uF63V10%	C9,11,12,14,64~71,73,74,76,77,80~83,91,95,119,120,126,127,140,121
63	014-2240211028	CAPACITOR	220nF63V10%	C93,94
64	014-6840211028	CAPACITOR	680nF63V10%	C84,85,113,115
65	014-1050200028	CAPACITOR	1uF63V5%	C104,106
66	011-1552502220	CAPACITOR	1.5uF25V20%	C134
67	011-4751002220	CAPACITOR	4.7uF10V20%	C50,51
68	006-1004051163	CAPACITOR	SM10u50V20%	C1,2,7,8,18~21,136,138,139
69	006-1004051162	CAPACITOR	10UF/50V	C112,114,130,131
70	011-1060632220	CAPACITOR	10uF6V3 20%	C56,57,60,62,116,118,122
71	011-4760632220	CAPACITOR	47uF6V3 20%	C3,135
72	006-4714101743	CAPACITOR	25V470u20%	C6
73	006-1024132053	CAPACITOR	1000uF35V20%	C16,17
74	006-2224132033	CAPACITOR	SM2200i F16V20%	C5
75	067-1104148000	DIODE	1N4148	D5
76	067-2204003000	DIODE	1N4003	D4
77	034-3442000108	BRIDGE DIODES	DF02M	D1,2
78	067-3305232000	DIODE	5.6V1/2W 1N5232	D3
79	018-0500940115	AUDION	2SK940 TO-92	Q1
80	018-2800110115	S.M.TRANSISTORS	J110 TO-92	Q2~5
81	017-2030000000	IC	MC14066BCP	IC17~23,42,43,48,53
82	017-1420000000	IC	CS3310-KP DIP	IC49
83	017-1200000000	IC	SSM2143P DIP	IC46,47
84	017-0340000000	IC	0P275GP	IC7,9,10,12,14,15,24,31,37,40,41,44,50
85	017-1750000000	IC	LT1115CN8	IC26,27
86	017-1270000000	IC	LM78L05	IC51
87	017-1510000000	IC	LM79L05	IC2,52



## 5. ELECTRONIC PARTS LIST

QUAD 99 PRE-AMPLIFIER

88	017-1760000000	IC	LM2940CT-5	IC1
89	017-2010000000	IC	MC14051BCP	IC38,39
90	017-1380000000	IC	LM317T(1.5A) TO-220	IC4,5
91	017-1390000000	IC	LM337T(1.5A) TO-220	IC3,6
92	017-0460000000	IC	LM339N	IC8,11,13,16,45
93	017-1770000000	IC	24LC04B/P DIP-8	IC30
94	017-1800000000	IC	P80C32 PLCC-44	IC28
95	017-1780000000	IC	SN75107BN DIP-14	IC32
96	017-1790000000	IC	SN75110AN DIP-14	IC33
97	017-2540000000	IC	311-B-15J AM-IC PSD/311	IC29
98	026-1594102072	COIL	AL1745-1R5K	L1
99	024-1090101015	RELAYS	G6H-2-100 9VDC	K1,2
100	051-3500000000	SOCKET	YKC21-3152(GOLD)	J2
101	051-4100000000	SOCKET	YKC21-3172(GOLD)	J3,4,8
102	813-0030000000	I/O SOCKET	5DAX15PNTD 15WAY	J5
103	055-2216040528	WIRE	16WAY RIBBON	J6
104	055-2310070566	WIRES	10WAY RIBBON	J7
105	059-1200001111	CRYSTAL	HC-49U 12.0M	XTAL1
106	058-4432000000	SOCKET	H2071Z01	SK1,2
107	031-4200507121	FUSE	50T020H	F1~4
108	031-4200512121	FUSE	50T040H	F5
109	050-0100070211	FUSES HOLDER	FUC-2	F1~5
110	086-1500000000	TERMINAL	H2071Z01	E1~8
1	088-1118003500	DIPLAY P.C.B		
2	053-1118001635	P.C.B		
3	002-1003033050	RESISTOR	10K1/8W J1206	R63~77,90,99,100
4	002-2701033050	RESISTOR	270ohm1/8W J1206	R1~3,20~48
5	002-3901033050	RESISTOR	390ohm1/8W J1206	R51~55,86
6	002-5601033050	RESISTOR	560ohm1/8W J	R14,16,19,49,104
7	002-1801033050	RESISTOR	180ohm1/8W J	R15,17,18,50,105
8	002-1002033050	RESISTOR	1K1/8W J1206	R91,92
9	002-1004033050	RESISTOR	100K1/8W J1206	R56~62

## 5. ELECTRONIC PARTS LIST

---

QUAD 99 PRE-AMPLIFIER

10	007-1004073010	CAPACITOR	100nF6.3V20%1206	C5,9~19,24
11	010-1060632010	CAPACITOR	10uF6.3V20%3216L(S)	C1,20~22
12	010-2250632010	CAPACITOR	2.2uF6.3V20%3216L(S)	C4
13	007-2200073060	CAPACITOR	22pF50V20%	C2,3
14	067-2204148110	DIODE	DL4148	D22
15	017-1990000000	IC	74HC138DS016 4*10	IC2
16	017-2000000000	IC	74HC165DS016 4*10	U3
17	017-2690000000	IC	74HC574S016 6.3*13	U4~11
18	810-0010000000	LED	EL-11-22SRUGC/TR8	D8~11
19	011-1070632220	CAPACITOR	100uF63V10%	C7
20	017-2430000000	IC	16C711-04/P	IC1
21	059-4000001113	CRYSTAL	HC49S 4MHZ	X1
22	018-3200653115	S.M.TRANSISTORS	ZTX653 TO-92	Q2,3
23	811-0010000000	DIODE	SB-2181CG	D8~11,24
24	058-1811000000	IC HOLDER	IC HOLDER	IC1
25	812-0010000000	CONNECTOR	1-215079-0	J1
26	017-2020000000	IC	TFMS5380	U1

---