

CUBE-60D

Issued by RJA

CAUTIONARY NOTES	2	
SPECIFICATIONS.....	2	
LOCATION OF CONTROLS	4	
LOCATION OF CONTROLS PARTS LIST	5	
EXPLODED VIEW(CABINET).....	6	
EXPLODED VIEW(CHASSIS).....	8	
PARTS LIST.....	10	
CHECKING THE VERSION NUMBER.....	14	
TEST MODE.....	14	
NOTE WHEN EXCHANGING AC CORD	16	
BLOCK DIAGRAM/WIRING DIAGRAM	18	
CIRCUIT BOARD(MAIN BOARD DIGITAL)	20	
CIRCUIT DIAGRAM(PANEL BOARD)	22	
		CIRCUIT DIAGRAM(MAIN BOARD DIGITAL PANEL BOARD)
		24
		CIRCUIT DIAGRAM(MAIN BOARD ANALOG)
		26
		CIRCUIT DIAGRAM(MAIN BOARD POWER SUPPLY)
		28



Copyright © 2004 ROLAND CORPORATION

All rights reserved. No part of this publication may be reproduced in any form without the written permission of ROLAND CORPORATION.

Roland

17058254E0

Printed in Japan (0500) (TP)

CAUTIONARY NOTES

PART LIST

Due to one or more of the following reasons, parts with parts code ***** cannot be supplied as service parts.

- Part supplied only as a component in a complete assembly
- Copyright does not permit the part to be supplied
- Part is sold commercially

SPECIFICATIONS

Rated Power Output

60 W

Nominal Input Level (1 kHz)

INPUT: -10 dBu/1 M

* 0dBu"0.775Vrms

Speaker

30 cm (12 inches)

Controls

POWER Switch, SELECT Switch

<JC CLEAN Channel>

BRIGHT Switch, VOLUME Knob

<LEAD Channel>

TYPE Switch (ACOUSTIC, BLACK PANEL, BRIT COMBO, TWEED, CLASSIC STACK, METAL STACK, R-FIER STACK, DYNA AMP), GAIN Knob, VOLUME Knob

<EQUALIZER>

BASS Knob, MIDDLE Knob, TREBLE Knob

<PRESENCE>

PRESENCE Knob

<EFX>

EFX Knob (CHORUS, FLANGER, PHASER, TREMOLO)

<DELAY/REVERB>

DELAY/REVERB Knob

Indicators

JC CLEAN Channel, LEAD Channel, EFX, DELAY/REVERB, POWER

Connectors

INPUT Jack (1/4" phone type)

RECORDING OUT/PHONES Jack (Stereo 1/4" phone type)

FOOT SW Jack (CH SELECT, EFX, DELAY/REVERB) (1/4" phone type)

EXT SPEAKER Jack (1/4" phone type)

LINE OUT Jack (1/4" phone type)

TUNER OUT Jack (1/4" phone type)

Power Supply

AC 117 V, AC 230 V, AC 240 V (50/60 Hz)

AC 220 V (60 Hz)

Power Consumption

60 W

Dimensions

410 (W) x 275 (D) x 440 (H) mm

16-3/16 (W) x 10-7/8 (D) x 17-3/8 (H) inches

Weight

14.5 kg / 32 lbs

Accessory

Owner's Manual ENGLISH" (#SD000453)

JAPANESE" (#SD000452)

Option

Foot Switch FS-5U (BOSS)

* *In the interest of product improvement, the specifications and/or appearance of this unit are subject to change without prior notice.*

LOCATION OF CONTROLS

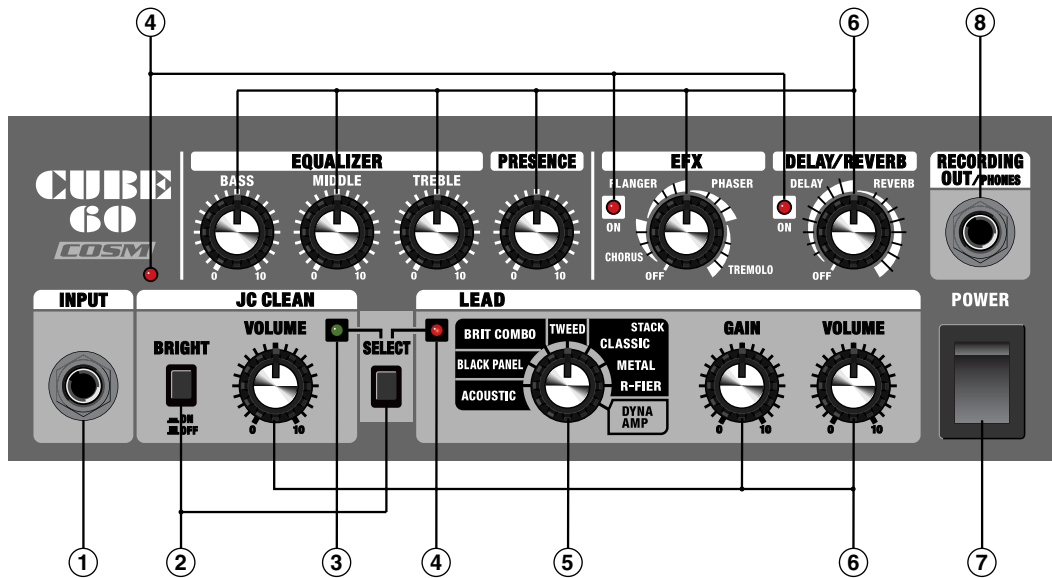
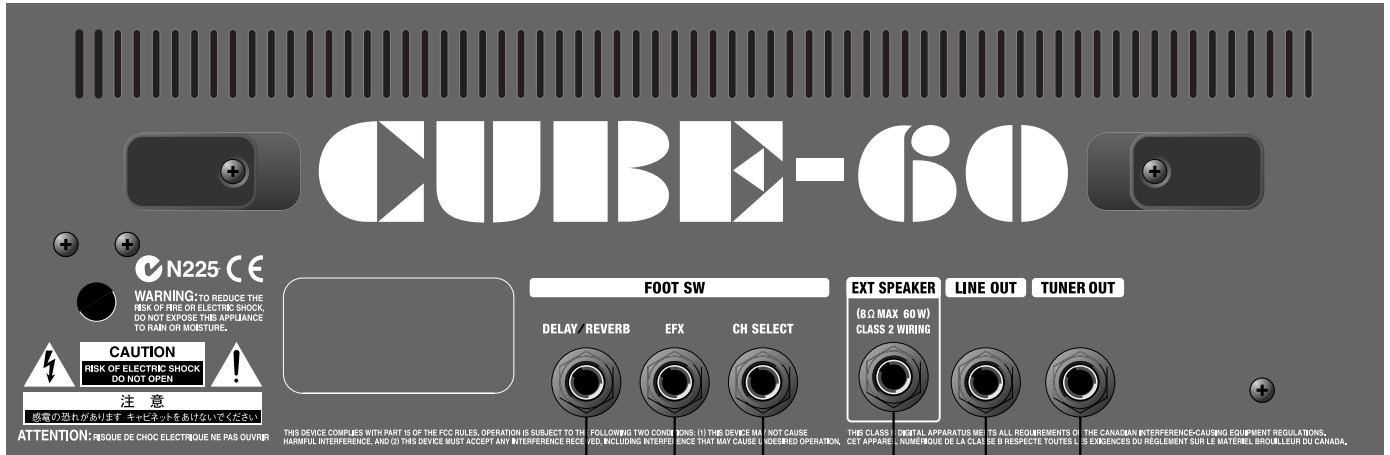

LOCATION OF CONTROLS PARTS LIST

No	PART CODE	CATEGORY	PART NAME	DESCRIPTION	Q'TY
1	13449146	JACK,EXT TERMINAL	6.5MM JACK	YKB21-5012 (W/SW)	1
	SD000042	SCREWS	JACK NUT		1
2	SD000099	SWITCH	PUSH SWITCH	ESB64619	2
	SD000082	KNOB,BUTTON	PUSH BUTTON		2
3	SD000044	DIODE	LED GREEN		1
4	SD000045	DIODE	LED RED		4
5	SD000488	SWITCH	ROTARY SWITCH	SR1712-0108-15F0A-N9-N	1
	17048631	SCREWS	VR ACCESSORY WASHER M9		1
	17048630	SCREWS	VR ACCESSORY NUT M9		1
	SD000043	KNOB,BUTTON	KNOB		1
	SD000483	MISCELLANEOUS	SW KNOB HIMERON	87-YP5-228-01M	1
6	SD000487	POTENTIOMETER	ROTARY POTENTIOMETER	RK09L1140C1T 10KB	9
	17048631	SCREWS	VR ACCESSORY WASHER M9		9
	17048630	SCREWS	VR ACCESSORY NUT M9		9
	SD000043	KNOB,BUTTON	KNOB		9
7	01786012	SWITCH	SEESAW SWITCH	JW-M11RKK	1
	01786045	MISCELLANEOUS	SW HOLDER	AT-217K	1
8	13449252	JACK,EXT TERMINAL	6.5MM JACK	YKB21-5006 (STEREO W/SW)	4
	SD000042	SCREWS	JACK NUT		4
9	SD000495	JACK,EXT TERMINAL	JACK	S2 BNB PC-P KINKED	1
	SD000485	SCREWS	JACK WASHER	S2 BNB	1
	SD000484	SCREWS	JACK NUT	S2 BNB	1
10	13449145	JACK,EXT TERMINAL	6.5MM JACK	YKB21-5010	2
	SD000042	SCREWS	JACK NUT		2

EXPLODED VIEW(CABINET)

[PARTS]

No	PART CODE	CATEGORY	PART NAME	DESCRIPTION	QTY
1	SD000467	CASING	CABINET ASSY		1
NOTE: *CABINET ASSY includes the following parts (2,4,5,7-9,12,14)					
2	HAEW00067	CASING	POAT TUBE		2
4	SD000066	CASING	TRIM		1
5	SD000459	CASING	CORNER PROTECTOR		4
7	SD000461	CASING	HANDLE RUBBER		1
8	SD000462	CASING	HANDLE PLATE		1
9	SD000463	CASING	HANDLE HOLDER		2
12	SD000078	CASING	RUBBER FOOT		4
14	SD000466	MISCELLANEOUS	ACOUSTICAL SPONGE	400X400X15T WHITE	1
3	SD000458	SPEAKER, BUZZER	SPEAKER 12" (8OHM)	WP900RP135-00F	1
6	SD000460	CASING	GRILLE		1
10	SD000017	CASING	BADGE		1
11	SD000464	MISCELLANEOUS	HIMERON W/ADH	6 X 50 X 0.5T	3
15	SD000465	MISCELLANEOUS	EVA PACKING W/ADH	60 X 5 X 1T	4

[SCREW]

No	PART CODE	PART NAME	DESCRIPTION	QTY
a	SD000068	SCREW 4X25	TRUSS TAPITITE A1 BZC	8
b	SD000432	SCREW 3X16	TRUSS TAPITITE A1 BZC	29
c	40010145	SCREW M4X25	TRUSS FE BZC	8
d	SD000019	SCREW 4X25	BINDING MACHINE BZC	8
e	SD000048	SCREW 5X35	OVALHEAD MACHINE BZC	4
f	40230778	SCREW 3X8	OVAL MACHINE BZC	2
g	40011689	SPEED NUT M3	F-TYPE	2
h	SD000370	PLATE WASHER	4.2X10X0.5T FEBC	4
i	SD000430	PLANE WASHER	D11 D4.1 T1 BLACK	4
j	*****			4

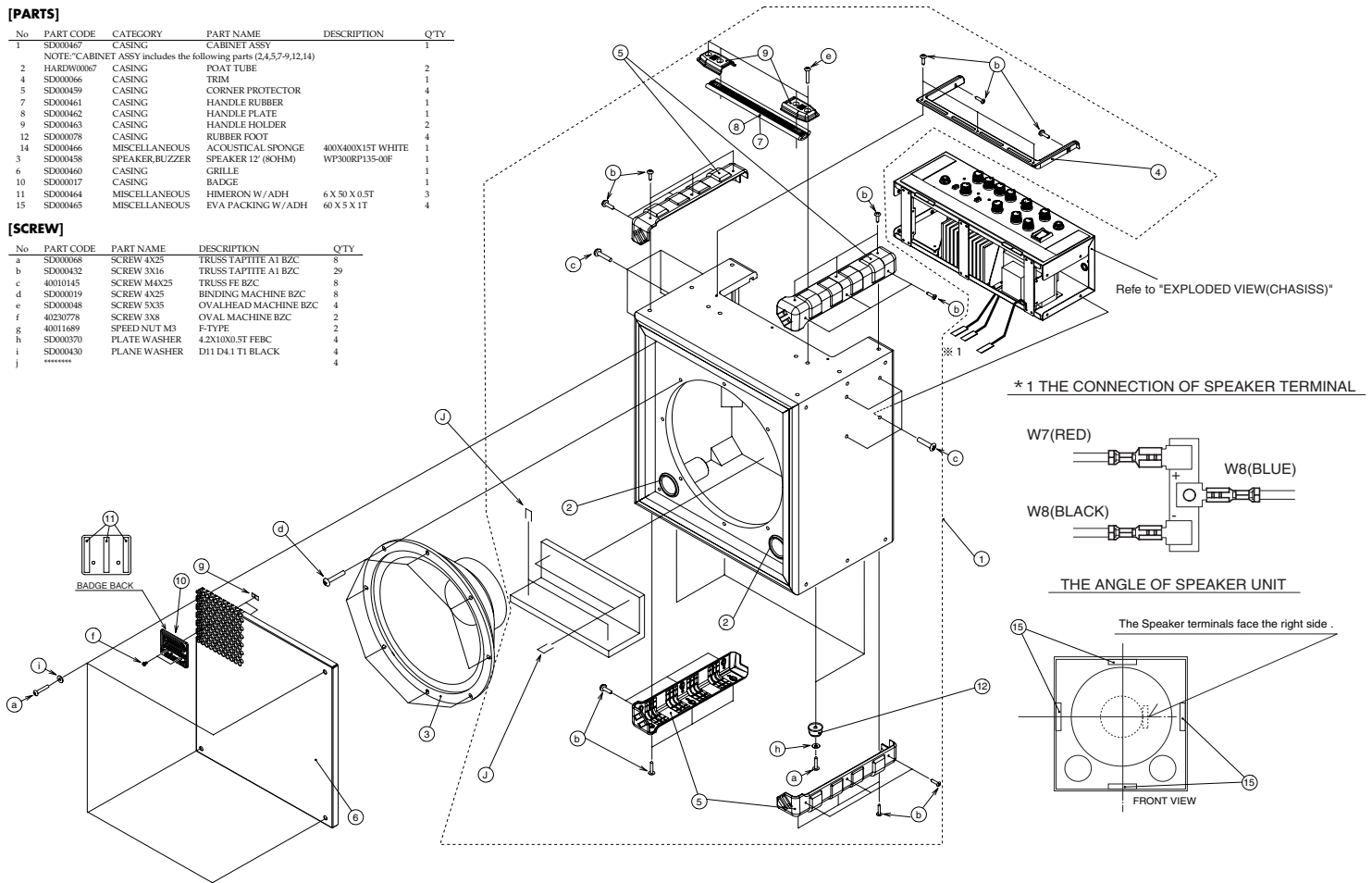

EXPLODED VIEW(CHASSIS)

[PARTS]

No	PART CODE	CATEGORY	PART NAME	DESCRIPTION	QTY
1	SD000469	TRANSFORMER	TRANSFORMER 230V/240V	ST-11785	1
1	SD000468	TRANSFORMER	TRANSFORMER 100V/117V	ST-11784	1
2	SD000012	AC CORD ASSY (Installed)	AC CORD	SP-023 230V	1
2	SD000014	AC CORD ASSY (Installed)	AC CORD	SP-301 117V	1
2	SD000015	AC CORD ASSY (Installed)	AC CORD	SP-302B 240V	1
2	SD000016	AC CORD ASSY (Installed)	AC CORD	SP-60 230VE	1
2	SD000095	AC CORD ASSY (Installed)	AC CORD	SP-18E 100V	1
3	SD000470	CHASSIS	CHASSIS		1
4	SD000471	CHASSIS	STAY		3
5	01786012	SWITCH	SEESAW SWITCH	JW-M11RKK	1
6	01786045	MISCELLANEOUS	SW HOLDER	AT-217K	1
7	SD000472	MISCELLANEOUS	HEATSINK		1
8	SD000473	MISCELLANEOUS	HEATSINK HOLDER		1
9	SD000043	KNOB,BUTTON	KNOB		10
10	SD000082	KNOB,BUTTON	PUSH BUTTON		2
11	22360705	CHASSIS	CORD HOOK		2
12	12369410RT	MISCELLANEOUS	AC CORD HOLDER	1702B	2
13	SD000483	MISCELLANEOUS	SW KNOB HIMERON	87-YPS-228-01M	1
14	SD000042	SCREWS	JACK NUT		7
15	SD000084	SCREWS	JACK NUT	52 BNB	1
16	SD000266	MISCELLANEOUS	AC CORD BAND (BLACK)		1
17	SD000475	MISCELLANEOUS	HIMERON	95 X 80 X 0.5T	1
18	SD000477	MISCELLANEOUS	PU SPONGE W / ADH	360 X 25 X 4T	1
19	SD000478	MISCELLANEOUS	PU SPONGE W / ADH	90 X 25 X 4T	2
21	SD000480	MISCELLANEOUS	EVA PACKING W/ADH	113 X 10 X 1T	2
22	SD000476	MISCELLANEOUS	HIMERON W/ADH	21 X 3 X 0.35T	2
23	SD000485	SCREWS	JACK WASHER	52 BNB	1
24	SD000481	MISCELLANEOUS	EVA PACKING W/ADH	100 X 30 X 1T	3
25	SD000482	MISCELLANEOUS	EVA PACKING W/ADH	100 X 13 X 1T	2
26	SD000474	WIRING, CABLE	WIRING W11	(1P BLUE)	1
27	SD000399	PWB ASSY	MAIN PCB ASSY		1
NOTE: Replacement MAIN PCB ASSY includes the followings parts.					
28	*****	PWB ASSY	DV BORD		1
29	*****	PWB ASSY	PHO BORD		1
30	*****	PWB ASSY	PS BORD		1
31	*****	PWB ASSY	AMP BORD		1
32	SD000408	PWB ASSY	PANEL ASSY		1

[SCREW]

No	PART CODE	PART NAME	DESCRIPTION	QTY
a	40011423	SCREW M3X6	PAN SEMS FECCM	5
b	40012867	SCREW M3X8	PAN MACHINE W/SW+FW ZC	19
c	40013078	SCREW M3X10	PAN MACHINE W/SW FE ZC	1
d	40237101	SCREW M3X8	PAN MACHINE W/SW+FW FE BZC	9
e	40013012	SCREW M4X10	PAN W SEMS FE BZC	4
f	40010301	SCREW M3X20	BINDING MACHINE BZC	2
g	40011756	FLANGE HEX NUT M3	ZC	2
h	40011767	FLANGE HEX NUT M4	FE ZC	1
i	22150501	STAND OFF	M3 L10C	3
j	17048630	VR ACCESSORY NUT M9		10
k	40011889	EXTERNAL TOOTH WASHER M4	FECCM	1
l	40011878	M3 EXTERNAL TOOTH WASHER	FECCM	1
m	17048631	VR ACCESSORY WASHER M9		10
n	SD000103	SCREW M4X25	PAN MACHINE W/SW BZC	2
o	40011889	EXTERNAL TOOTH WASHER M4	FECCM	1
p	40011767	FLANGE HEX NUT M4	FE ZC	1

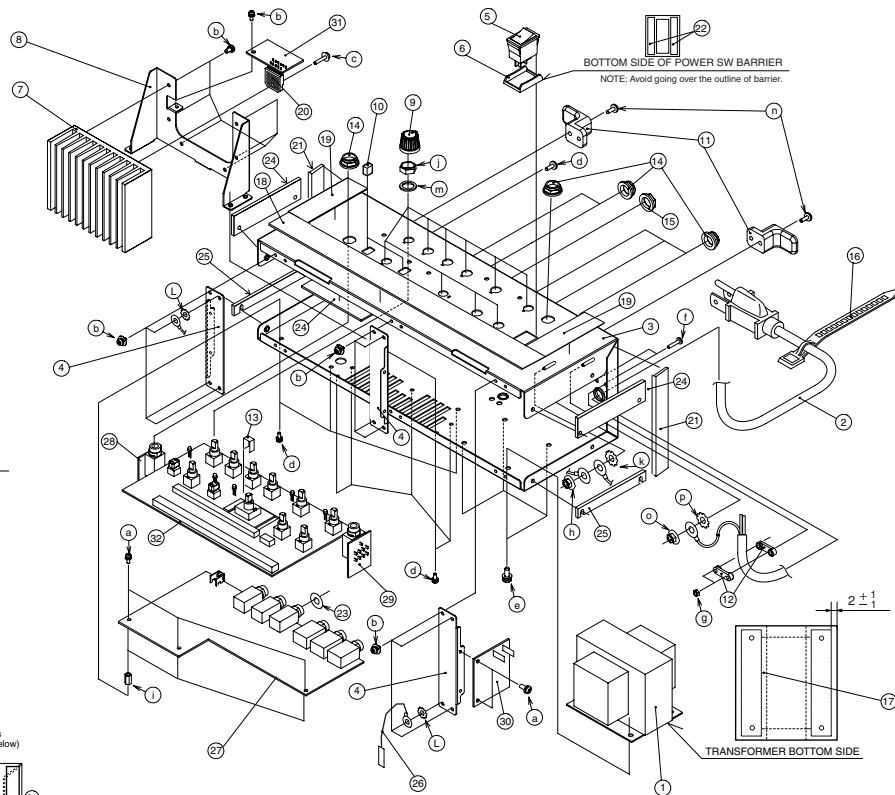

POSITIONING OF CUSHIONS ON CHASSIS(measuring scale)

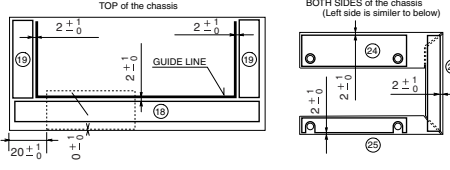

PARTS LIST

SAFETY PRECAUTIONS:
The parts marked Δ have safety-related characteristics. Use only listed parts for replacement.

Due to one or more of the following reasons, parts with parts code ***** cannot be supplied as service parts.

- Part supplied only as a component in a complete assembly
- Copyright does not permit the part to be supplied
- Part is sold commercially

NOTE: The parts marked # are new. (initial parts) The description "Q'TY" means a necessary number of the parts per one product.

on P=PANEL PCB, on M=MAIN BOARD.

CASING					QTY
	SD000017	BADGE			1
#	SD000460	GRILLE			1
#	SD000467	CABINET ASSY			1
	NOTE:Spare parts for CABINET ASSY includes the following parts .				
#	SD000459	CORNER PROTECTOR			4
#	SD000463	HANDLE HOLDER			2
#	SD000462	HANDLE PLATE			1
#	SD000461	HANDLE RUBBER			1
	HARDW00067	PORT TUBE			2
	SD000078	RUBBER FOOT			4
	SD000066	TRIM			1
CHASSIS					
#	SD000470	CHASSIS			1
	22360705	CORD HOOK			2
#	SD000471	STAY			3
KNOB,BUTTON					
	SD000043	KNOB			10
	SD000082	PUSH BUTTON			2
SWITCH					
#	SD000488	ROTARY SWITCH	SR1712-0108-15F0A-N9-N	RSW1 on P	1
	Δ 01786012	SEESAW SWITCH	JW-M11RKK		1
	SD000099	PUSH SWITCH	ESB64619	PSW1,PSW2 on P	2
JACK,EXT TERMINAL					
	13449146	6.5MM JACK	YKB21-5012 (W/SW)	JK1 on M	1
	13449145	6.5MM JACK	YKB21-5010	JK4,JK5 on M	2
	13449252	6.5MM JACK	YKB21-5006 (STEREO W/SW)	JK2,JK7,JK8,JK9 on M	4
#	Δ SD000495	JACK	S2 BNB PC-P KINKED	JK6 on M	1
SPEAKER,BUZZER					
#	Δ SD000458	WP300RP135-00F	SPEAKER 12' (80HM)		1
PWB ASSY					
#	SD000399	MAIN PCB ASSY	FOR 100/117V		1
	NOTE:Spare parts for MAIN PCB ASSY includes the following parts.				
	*****	MAIN BOARD ASSY			1
	*****	PS-1 BOARD			1
	*****	IN BOARD			1
	*****	AMP BOARD			1
	*****	PHO BOARD			1
	*****				1
	SD000110	FUSE	5ST 2A 250V	FUSE 1 (100/117V)	1
	NOTE: Replacement MAIN PCB ASSY is for 100V/117V version exclusive use.				
	MAIN PCB ASSY for 100V/117V version differs from 230V/240V version in FUSE system only.				
	When using PCB (230V/240V) version, be sure to make the following modifications.				
	1. Replace fuse (FUSE 1 on PS1 BOARD) to specific one. (P/No. F2559109 5ST 800mA/250V)				
	2. Please change into the check marking "100/117V T2AL 250V" from "230/240V T800mA 250V" on PS1 BOARD.				
	Please refer to TABLE A.				

Table A

100V/117V	T2AL 250V	→	100V/117V	T2AL 250V
230V/240V	T800mA 250V		230V/240V	T800mA 250V

PWB ASSY

1

SD000408 PANEL PCB ASSY

IC

	△	F5209151	LM3886TF	IC(POWER AMP IC)	IC6 on M	1
#	△	SD000493	NJM78M12DLA	IC (V RGL)	IC15 on M	1
#	△	SD000494	NJM79M12DLA	IC (V RGL)	IC16 on M	1
#		03015923	S-80130ANMC	IC (RESET)	IC3 on M	1
	△	01678512	UPC2933T-T2	IC (REGULATOR)	IC9 on M	1
		15289154	UPC4072G2-E1	IC (JFET OP)	IC10 on M	1
		02565501	TC220CCA0AF-B01(MR3)	IC (DSP)	IC2 on M	1
		01340789	BU9480F	IC (D/A CONVERTER)	IC5 on M	1
#		03567234	UPD780034AGK-B17-9ET	IC (CPU)	IC1 on M	1
		15169596	TC74HC4051AP	IC (CMOS)	IC7 on P	1
		15189261	M5218AFP-600E	IC (BIPOLAR OP AMP)	IC13,IC14 on M	2
		00346445	NJM2100M(TE3)	IC (BIPOLAR OP AMP)	IC12 on M	1
		01125012	NJM4556AM	IC (BIPOLAR OP AMP)	IC17 on M	1
		02451434	AK4552VT	IC (AD/DA)	IC4 on M	1
		02678945	BU2090	IC	IC8 on P	1

TRANSISTOR

		15119144	2SA1048-GR(TPE4)	TRANSISTOR	Q5 on M	1
		15309104	2SA1586-GR(TE85R)	TRANSISTOR	Q8,Q9,Q23 on M	3
		15129179	2SC2458-GR(TPE4)	TRANSISTOR	Cp6 on M	1
		15319107	2SC4116-GR(TE85R)	TRANSISTOR	Q10,Q11,Q19,Q20,Q24,Q25 on M	6
		15329536	RN1442-A(TE85L)	TRANSISTOR	Q12,Q14,Q16,Q17 on M	4
		15329103T0	2SK880-GR(TE85R)	FET	Q21,Q22 on M	2

DIODE

	△	15019505	RD36EB2	ZENER DIODE		
#	△	15019689	RD4.3E B2	ZENER DIODE		
		01019534	1SS355 TE-17	SWITCHING DIODE	D5,D6,D7,D10,D11 on M	5
		SD000045	LED RED		LED1,LED2,LED3,LED6 on P	4
		SD000044	LED GREEN		LED5 on P	1
	△	SD000239	1N4007G 1A 1000V P=10MM	DIODE		
		02457445	1SS367	DIODE	D8,D9 on M	2
	△	F5039116	FL402 BRIDGE	DIODE	BD1 on M	1
	△	15019654	RD16EB2-T1	DIODE		
	△	SD000120	AM152	BRIDGE DIODE	BD2 on M	1
		15339120T0	1SS302(TE85R)	ARRAY DIODE	DA1,DA2,DA3,DA4,DA5,DA8 on M	6

RESISTOR

		00344278	EXBV8V102JV	RESISTOR ARRAY	RA3,RA4 on M	2
		15409113	EXBV8V103JV	RESISTOR ARRAY	RA1,RA2 on M	2
	△	C0000044	0.1 OHM 2W	METAL OXIDE RESISTOR	R17 on M	1
#	△	SD000510	120 2W	METAL OXIDE RESISTOR	R141 on M	1
	△	C0000042	27 OHM 1/2W	METAL OXIDE RESISTOR	R18 on M	1
		C0000004	82 OHM 1/2W	CARBON RESISTOR	R146,R147 on M	2
		13749791T0	SR25TRE 561 J	CARBON RESISTOR	R38,R69 on M	2

POTENTIOMETER

#		SD000487	RK09L1140C1T 10KB	ROTARY POTENTIOMETER	VR1-9 on P	9
---	--	----------	-------------------	----------------------	------------	---

CAPACITOR

		00239523	AMZV0050J183 0200	POLYEST. CAPACITOR	C3 on M	1
		00239601	AMZV050J104 200 0.1UF 50V	POLYEST. CAPACITOR	C16,C18,C45 on M	3
	△	SD000246	EC8472MH 4700P/250V	LINE CAPACITOR (SEC)	C152,C140 on M	2
	△	SD000247	PY17FY472ML0 4700P/250V	LINE CAPACITOR (PRI)	C151 on M	1
#	△	SD000509	1000UF/35V 105DO	ELECTROLYTIC CAPACITOR	C153,C142 on M	2
#	△	SD000507	100UF/25V 105DO	ELECTROLYTIC CAPACITOR	C30,C33,C68,C70,C112,C146,C149 on M	7
#	△	SD000505	10UF/50V 105DO	ELECTROLYTIC CAPACITOR	C136,C11 on M	2
#	△	SD000504	1UF/50V 105DO	ELECTROLYTIC CAPACITOR	C44,C65,C137,C74,C75,C195,C197 on M	7
#	△	SD000508	220UF/25V 105DO	ELECTROLYTIC CAPACITOR	C145,C156 on M	2
#	△	SD000506	47UF/50V 105DO	ELECTROLYTIC CAPACITOR	C138,C2 on M	2
	△	SD000352	3300UF/50V	ELECTORIC CAPACITOR	C141,C139 on M	2

CRYSTAL,RESONATOR

		02673278	CX-49G 11.2896MHZ	CRYSTAL	X2 on M	1
		02673267	CX-49G 5MHZ	CRYSTAL	X1 on M	1

FUSE,FUSE HOLDER

	△	F2559307	RADIAL TYPE	MRT 100MA/250V	FUSE6 on M	1
	△	F2559305	RADIAL TYPE	MRT 2 A	FUSE2,FUSE3 on M	2
#	△	SD000503	FUSE(RADIAL TYPE)	MRT315MAL/250V	FUSE4,FUSE5 on M	2
	△	SD000251	FUSE HOLDER	FC-201	for FUSE1 on M	2
	△	F2559504	FUSE 5ST 2A/250V		FUSE1 on M	1

CONNECTOR

		13369570	B2B-PH-K-S (2P)	CONNECTOR	CN5 on M	1
		03014001	B5B-PH-K-S JST(PB FREE)	CONNECTOR	CN6 on M	1
	△	13369981	B5P-VH 7A /250V	CONNECTOR	CN13 on M	1
		03014023	B9B-PH-K-S JST(PB FREE)	CONNECTOR	CN8 on M	1

WIRING, CABLE

#		SD000490	WIRING W4	(9P WHITE)	CN9 on M	1
#		SD000498	WIRING W3	(5P)	CN14 to CN15 on M	1
#		SD000491	WIRING W5	(5P WHITE)	CN7 on M	1
#		SD000492	WIRING W6	(3P WHITE)	WP13 to WP14 on M	1
#		SD000496	WIRING W1	(2P)	CN4	1
#		SD000502	WIRING W10	(1P)	WP7,WP10,WP11	3
#	△	SD000501	WIRING W9	(1P)	WP1,WP2	2
#	△	SD000499	WIRING W7	(1P RED)	SP1	1
#	△	SD000474	WIRING W11	(1P BLUE)	CHASSIS TO SPEAKER	1
#	△	SD000500	WIRING W8	(1P BLACK)	SP2	1
#		SD000497	WIRING W2	(12P)	WP15 to WP16	1

TRANSFORMER

#	△	SD000469	ST-11785	TRANSFORMER 230V/240V		1
#	△	SD000468	ST-11784	TRANSFORMER 100V/117V		1

AC CORD ASSY (Installed)

	△	SD000012	SP-023 230V	AC CORD		1
	△	SD000095	SP-18E 100V	AC CORD		1
	△	SD000014	SP-301 117V	AC CORD		1
	△	SD000015	SP-502B 240V	AC CORD		1
	△	SD000016	SP-60 230VE	AC CORD		1

SCREWS

		40011756	FLANGE HEX NUT M3	ZC	for AC CORD BUSH 1702B	2
		SD000432	SCREW 3X16	TRUSS TAPTITE A1 BZC	for TRIM, CORNER	29
		SD000068	SCREW 4X25	TRUSS TAPTITE A1 BZC	for GRILLE, RUBBER FOOT	8
		40010145	SCREW M4X25	TRUSS FE BZC	for CHASSIS	8
#		SD000484	JACK NUT	S2 BNB	for JK6 (EXT SP)	1
#		SD000485	JACK WASHER	S2 BNB	for JK6 (EXT SP)	1
		40013012	SCREW M4X10	PAN W SEMS FE BZC	for TRANSFORMER	4
		40011423	SCREW M3X6	PAN SEMS FECM	for PCB	5
		SD000103	SCREW M4X25	PAN PACHINE W/SW BZC	for AC CORD HOOK	2
		40012867	SCREW M3X8	PAN MACHINE W/SW+PW ZC	for STAY, HEATSINK	19
		40237101	SCREW M3X8	PAN MACHINE W/SW+PW FE BZC	for STAND OFF, HEATSINK HOLDER, TERMINAL	9
		40013078	SCREW M3X10	PAN MACHINE W/SW FE ZC	for POWER IC	1
		SD000048	SCREW 5X35	OVALHEAD MACHINE BZC	for HANDLE	4
		40230778	SCREW 3X8	OVAL MACHINE BZC	for LOGO BADGE	2
		22150501	STAND OFF	M3 L10C	for PCB	3
		40011889	EXTERNAL TOOTH WASHER M4	FECM	for Wiring GND to CHASSIS	1
		40011878	M3 EXTERNAL TOOTH WASHER	FECM	for Wiring GND to STAY	1
		40011767	FLANGE HEX NUT M4	FE ZC	for Wiring GND	2
		40011689	SPEED NUT M3	F-TYPE	for LOGO BADGE	2
		SD000430	PLANE WASHER	D11 D4.1 T1 BLACK	for GRILLE	4
		SD000019	SCREW 4X25	BINDING MACHINE BZC	for SPEAKER	8
		40010301	SCREW M3X20	BINDING MACHINE BZC	for AC CORD BUSH 1702B	2
		SD000370	PLATE WASHER	4.2X10X0.5T FEBC	for RUBBER FOOT	4
		SD000042	JACK NUT			7
		17048630	VR ACCESSORY NUT M9		for VOLUME, ROTARY SWITCH	10
		17048631	VR ACCESSORY WASHER M9		for VOLUME, ROTARY SWITCH	10

PACKING

		SD000264	EAN CAP	PAD		8
#		SD000457	BOTTOM PAD	CARDBOARD		1
#		SD000456	TOP PAD	CARDBOARD		1
#		SD000455	PACKING CASE			1

MISCELLANEOUS

#	SD000489	LED HOLDER	LH-5-7	for LED	5
	F3459105	TERMINAL	JH-8M3	TER3	1
	01786045	SW HOLDER	AT-217K		1
#	△	SD000475	HIMERON	95 X 80 X 0.5T	for TRANSFORMER
#	△	SD000478	PU SPONGE W / ADH	90 X 25 X 4T	for CHASSIS TOP
#	△	SD000483	SW KNOB HIMERON	87-YP5-228-01M	for ROTARY SWITCH
#	△	SD000465	EVA PACKING W/ADH	60 X 5 X 1T	4
#	△	SD000464	HIMERON W/ADH	6 X 50 X 0.5T	for LOGO BADGE
#	△	SD000466	ACOUSTICAL SPONGE	400X400X15T WHITE	1
#	△	SD000477	PU SPONGE W / ADH	360 X 25 X 4T	for CHASSIS TOP
	△	SD000252	AC TERMINAL	352-TX119	TER1,TER2
#	△	SD000476	HIMERON W/ADH	21 X 3 X 0.35T	2
	△	12369410RT	AC CORD HOLDER	1702B	2
#	△	SD000479	PU SPONGE W / ADH	160 X 10 X 11T	for PANEL BOARD
#	△	SD000482	EVA PACKING W/ADH	113 X 13 X 1T	2
#	△	SD000480	EVA PACKING W/ADH	113 X 10 X 1T	2
#	△	SD000481	EVA PACKING W/ADH	100 X 30 X 1T	3
	△	SD000266	AC CORD BAND (BLACK)		1
#	△	SD000472	HEATSINK		1
#	△	SD000473	HEATSINK HOLDER		1

ACCESSORIES (Standard)

#	SD000452	OWNER'S MANUAL	JAPANESE		1
#	SD000453	OWNER'S MANUAL	ENGLISH		1

CHECKING THE VERSION NUMBER

1. Set up the CUBE-60 as described below.

[Connections]

Connect an FS-5U foot switch to each of the three FOOT SW jacks (CH SELECT, EFX, DELAY/REVERB).

Set the FS-5U polarity switches to the jack side. Do not connect anything to any of the other jacks.

[Panel Settings]

- POWER SW: OFF
- BRIGHT SW: OFF
- SELECT SW: OFF
- LEAD AMP TYPE SW: ACOUSTIC
- All VRs: Minimum



The version number will not be displayed unless the connections and panel settings are correct.

2. Press down on the foot switch FS-5U connected to the DELAY/REVERB jack while turning on the power.
3. While continuing to press the FS-5U connected to the DELAY/REVERB jack, press the FS-5U connected to the EFX jack and the FS-5U connected to the CH SELECT jack, in that order, within four seconds. After all the LEDs turn on, they begin to flash.
4. Press the FS-5U connected to the DELAY/REVERB jack again. This switches the CUBE-60 to version display status. Check the version according to which of the POWER LED, the SELECT LED (green), and the SELECT LED (red), are lit or off.

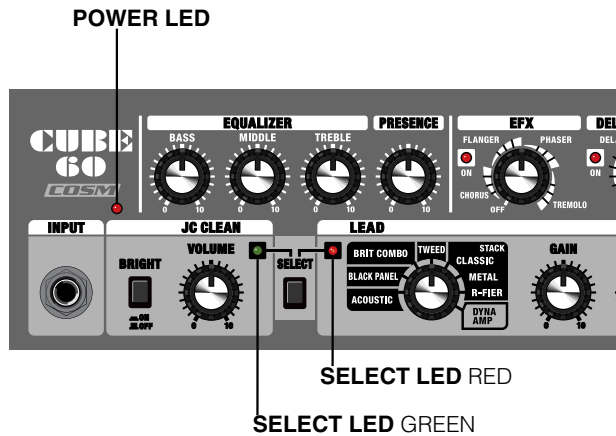

LED	1.00	1.01	1.02	1.03	1.04	1.05	1.06
POWER	o	x	o	x	o	x	o
SELECT(Green)	x	o	o	x	x	o	o
SELECT(Red)	x	x	x	o	o	o	o

o: Lit
x: Off



If the EFX LED or DELAY/REVERB LED are lit at this time, the CPU or DSP self-diagnosis is failure(NG).

The version is still indicated even when this occurs.

5. Turn off the power.

TEST MODE

Required Equipment

- 1 pair of headphones
- 3 BOSS FS-5U foot switches (sold separately)
- 3 foot switch connector cables (phone-phone)

Entering Test Mode

1. Set up the CUBE-60 as described below.

[Connections]

- Connect an FS-5U foot switch to each of the three FOOT SW jacks (CH SELECT, EFX, DELAY/REVERB).
- Set the FS-5U polarity switches to the jack side.
- Do not connect anything to any of the other jacks.

[Panel Settings]

- POWER SW: OFF
- BRIGHT SW: OFF
- SELECT SW: OFF
- LEAD AMP TYPE SW: ACOUSTIC
- All VRs: Minimum



The CUBE-60 will not enter Test mode unless the connections and panel settings are correct.

2. Press down on the foot switch FS-5U connected to the DELAY/REVERB jack while turning on the power.
3. While continuing to press the FS-5U connected to the DELAY/REVERB jack, press the FS-5U connected to the EFX jack and the FS-5U connected to the CH SELECT jack, in that order, within four seconds. After all the LEDs turn on, they begin to flash.

The LEDs are used in confirming whether tests have passed or failed, so confirm here that all LEDs are capable of working properly.

Quitting Test Mode

Turn off the power to exit Test mode.

Skipping

Tests cannot be skipped in Test mode.

Test Items

1. Version Display/CPU and DSP Test (determined automatically)
2. Volume Test
3. Switch Test

Test Details

1. Version Display/CPU and DSP Test (determined automatically)

Press the FS-5U connected to the DELAY/REVERB jack.

The version is indicated by on/off status of the POWER LED, the SELECT LED (green), and the SELECT LED (red).

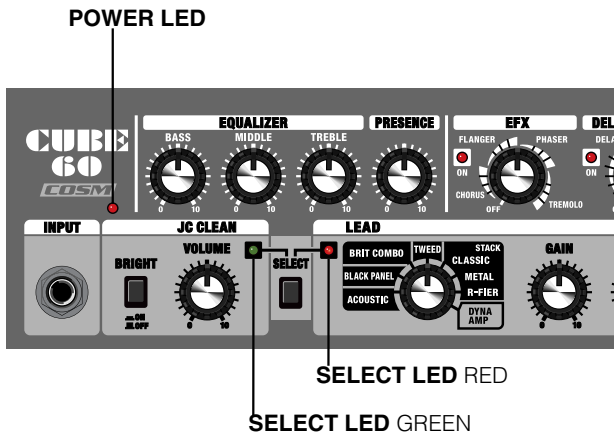

LED	1.00	1.01	1.02	1.03	1.04	1.05	1.06
POWER	o	x	o	x	o	x	o
SELECT(Green)	x	o	o	x	x	o	o
SELECT(Red)	x	x	x	o	o	o	o

o: Lit

x: Off

EFX LED lit: CPU NG (failure)

DELAY/REVERB LED lit: DSP NG (failure)

If there is a failure in any of these tests, the procedure does not advance to the next test.

2. Volume Test



When a volume knob is adjusted, the DSP automatically starts the oscillator tone, so if speaker is left connected, the sound is then output from the speaker. The volume changes according to the knob position until reading is completed.

* We recommend connecting headphones to the headphone jack to prevent sounds from being output from the CUBE-60's speaker.

Press the FS-5U connected to the DELAY/REVERB jack.

All LEDs go out.

Confirm the results of the volume test as described below.

The reading of each volume is detected at four positions (in four ranges).

Check confirmation of the detected volume with the SELECT (green) and SELECT (red) LEDs.

Knob Position	SELECT(Green)	SELECT(Red)
(1) "0" or "OFF"	x	x
(2) Left Half	o	x
(3) Right Half	o	o
(4) "10" or Max.	x	x

o: Lit

x: Off

Rotate the volume knob slowly from the (1) to (4) positions. Confirm that the SELECT (red) LED lights when the knob is at center position.

Reading of the volume is completed with the detection of (4).

The test proceeds in the following sequence.

JC CLEAN VOLUME -> BASS -> MIDDLE -> TREBLE -> PRESENCE -> EFX -> DELAY/REVERB -> LEAD VOLUME -> LEAD GAIN

If a mistake is made in the testing sequence, the operation at that point is disregarded, and only the volume adjustment knob targeted in the test is detected.

If any volume level (1)-(4) for any knob is not detected, the procedure does not advance to the next test. The tone stops after testing of the last volume knob.

3. Switch Test



If there is a failure in any of these tests, the procedure does not advance to the next test.

1. BRIGHT Switch Test

Press the BRIGHT switch. If the test results in OK (pass), the POWER LED lights.

2. SELECT Switch Test

Press the SELECT switch. If the test results in OK, the SELECT (green) LED lights.

3. RECORDING OUT /PHONES Jack Switch Test

Plug the headphones into the RECORDING OUT /PHONES jack. If the test results in OK, the SELECT (red) LED lights.

4. DELAY/REVERB Jack Switch Test

Unplug the cable connected to the FS-5U from the DELAY/REVERB jack. If the test results in OK, the SELECT (red) LED goes off.

5. EFX Jack Switch Test

Unplug the cable connected to the FS-5U from the EFX jack. If the test results in OK, the SELECT (green) LED goes off.

6. CH SELECT Jack Switch Test

Unplug the cable connected to the FS-5U from the CH SELECT jack. If the test results in OK, the POWER LED goes off.

After this, the SELECT (green) and SELECT (red) LEDs flash for 1.5 seconds, then the SELECT (green) LED remains lit.

7. AMP TYPE Switch Test

Slowly adjust the switch in the following sequence, and confirm the lighting status of the SELECT (green) and SELECT (red) LEDs.

TYPE	SELECT (Green)	SELECT (Red)
ACOUSTIC	o	x
BLACK PANEL	x	o
BRIT COMBO	o	x
TWEED	x	o
CLASSIC STACK	o	x
METAL STACK	x	o
R-FIER STACK	o	x
DYNA AMP	x	o

o: Lit

x: Off

This completes testing.

Turn the power off.

WHEN EXCHANGING AC CORD

Please note the following cautions when exchanging the AC cord.

Cautions

Before soldering and terminal, wind the wire 1.5 times around the terminal (refer to Fig. 1).

Fig. 1

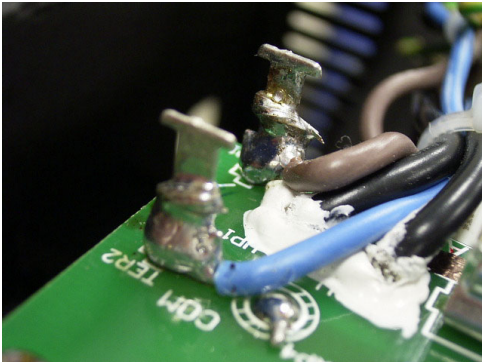

When removing the AC cord from the board, be sure not to leave any wiring debris on the terminals.

Ensure a minimum of 6 mm between electrodes (including portion with winding). (Refer to fig2)

Fig. 2

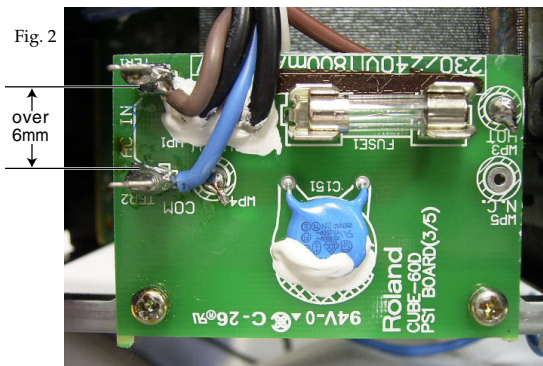

BLOCK DIAGRAM/WIRING DIAGRAM

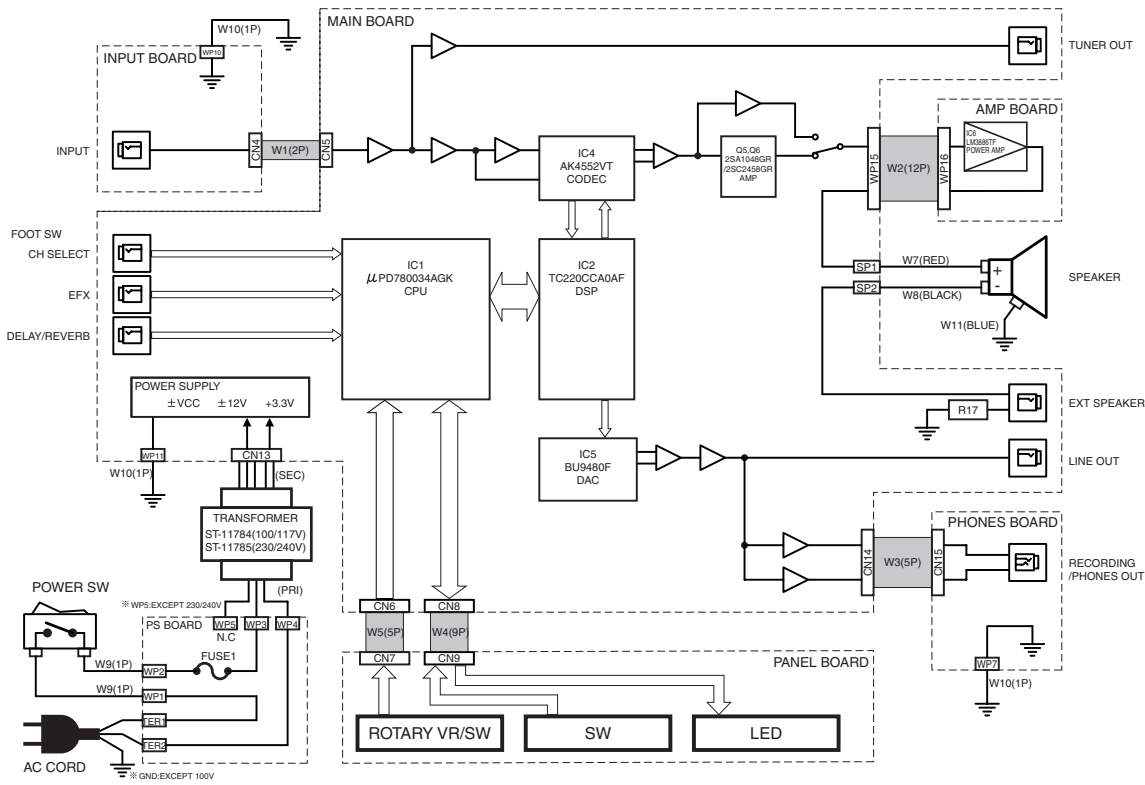

PART CODE	PART NAME	DESCRIPTION
SD000496	WIRING W1	(2P)
SD000497	WIRING W2	(12P)
SD000498	WIRING W3	(5P)
SD000499	WIRING W4	(9P WHITE)
SD000491	WIRING W5	(5P WHITE)
SD000492	WIRING W6	(3P WHITE)
SD000499	WIRING W7	(1P RED)
SD000500	WIRING W8	(1P BLACK)
SD000501	WIRING W9	(1P)
SD000502	WIRING W10	(1P)
SD000474	WIRING W11	(1P BLUE)

CIRCUIT BOARD(MAIN BOARD DIGITAL)

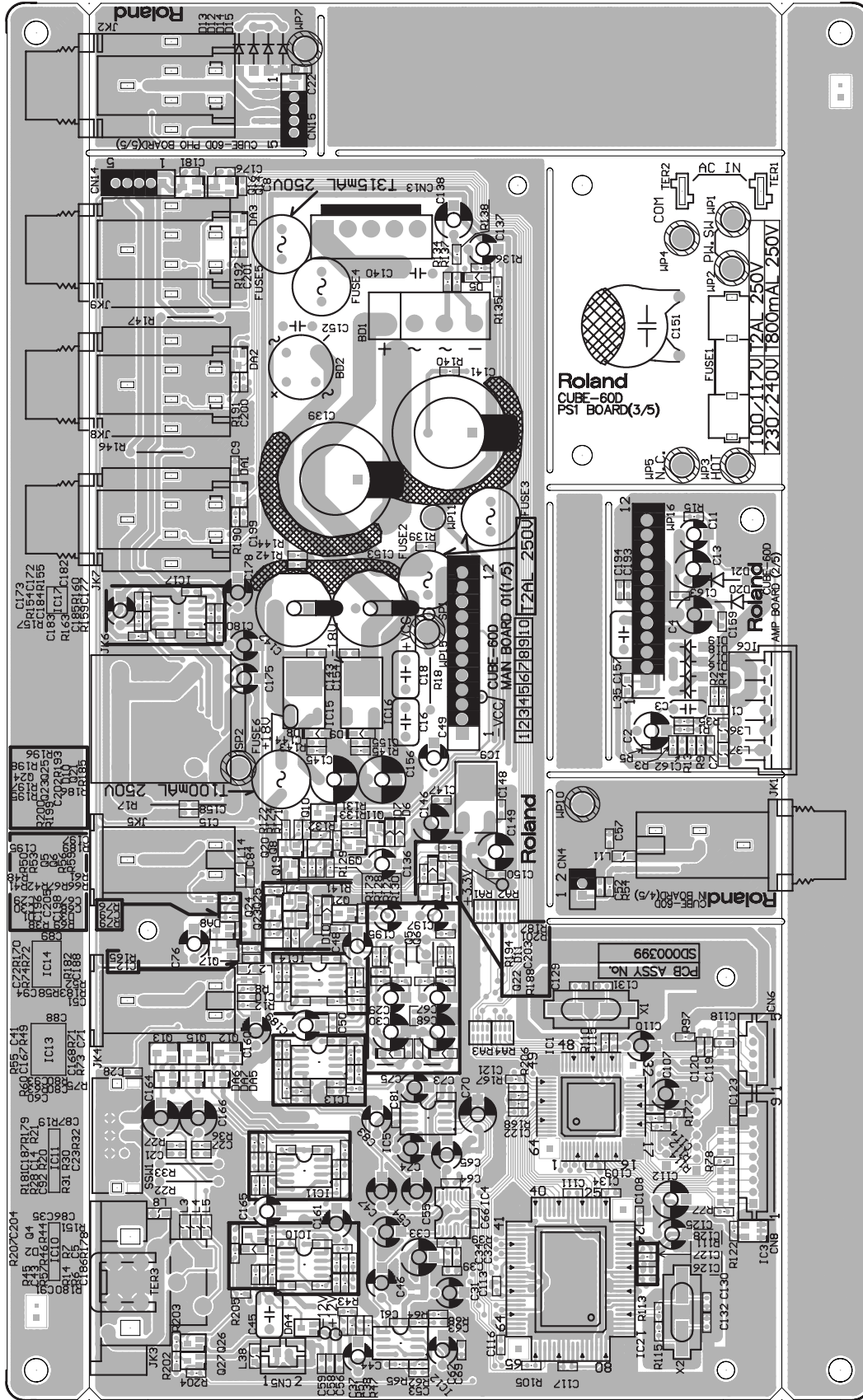

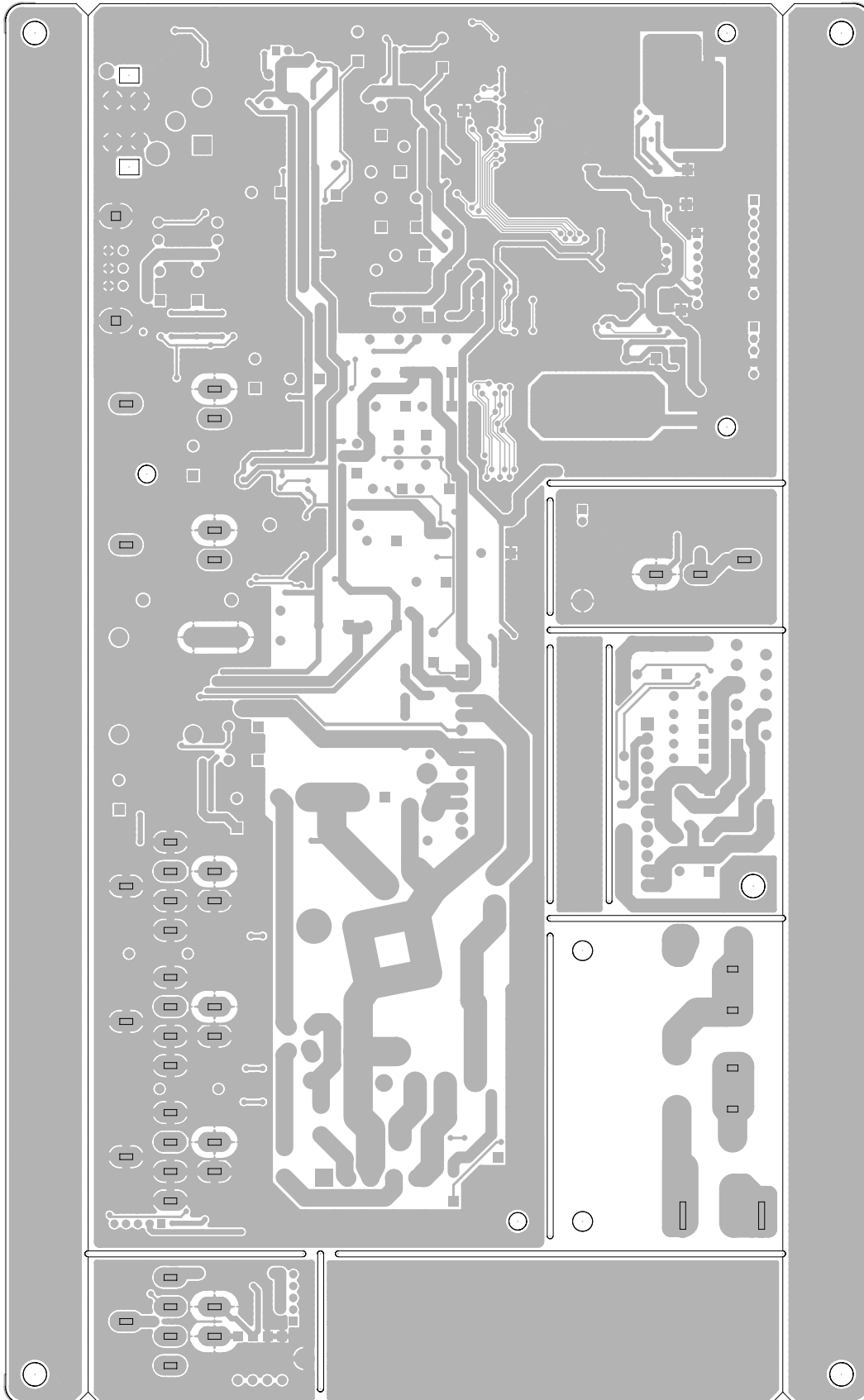

CIRCUIT DIAGRAM(PANEL BOARD)

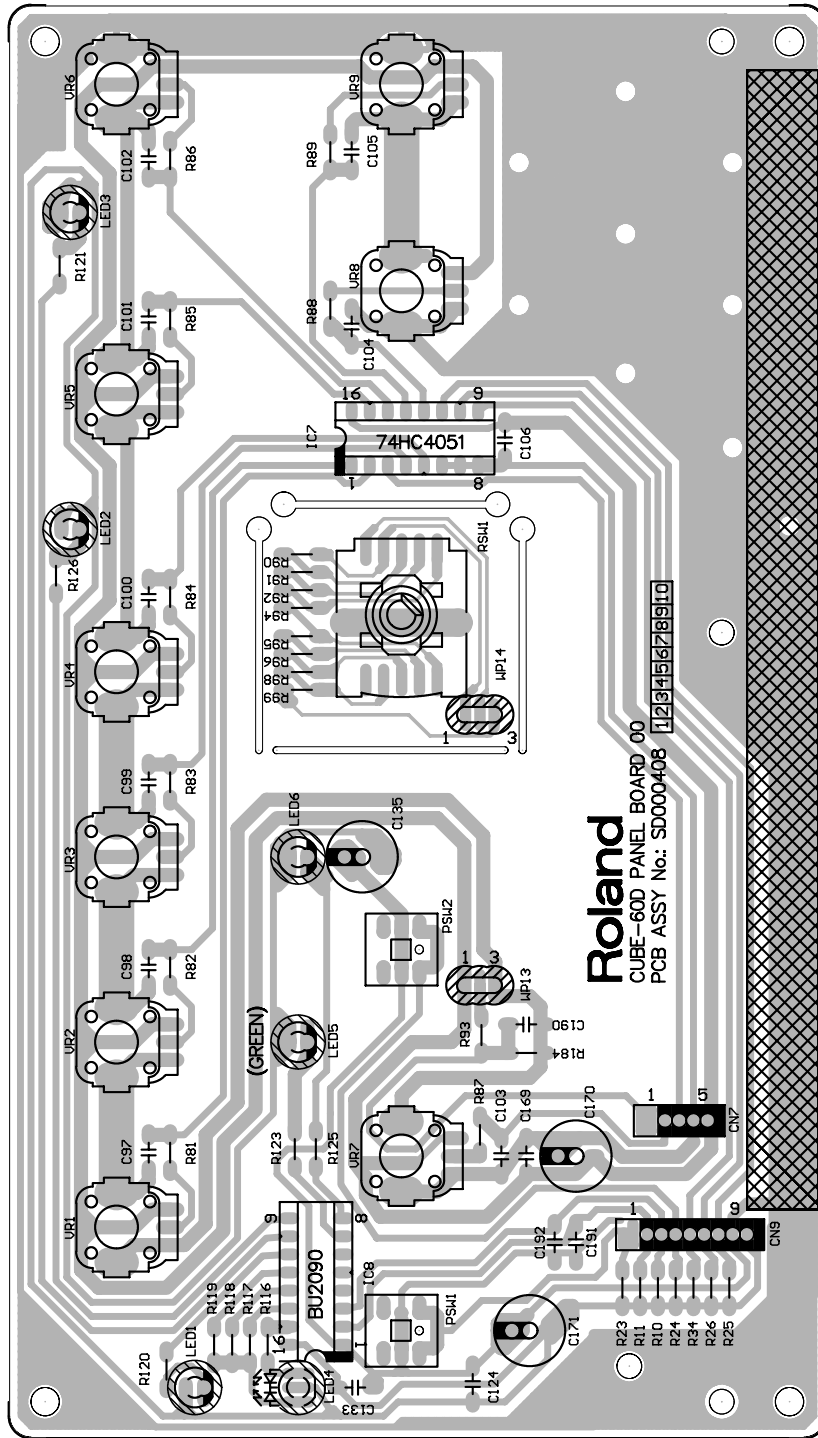

CIRCUIT DIAGRAM(MAIN BOARD DIGITAL)

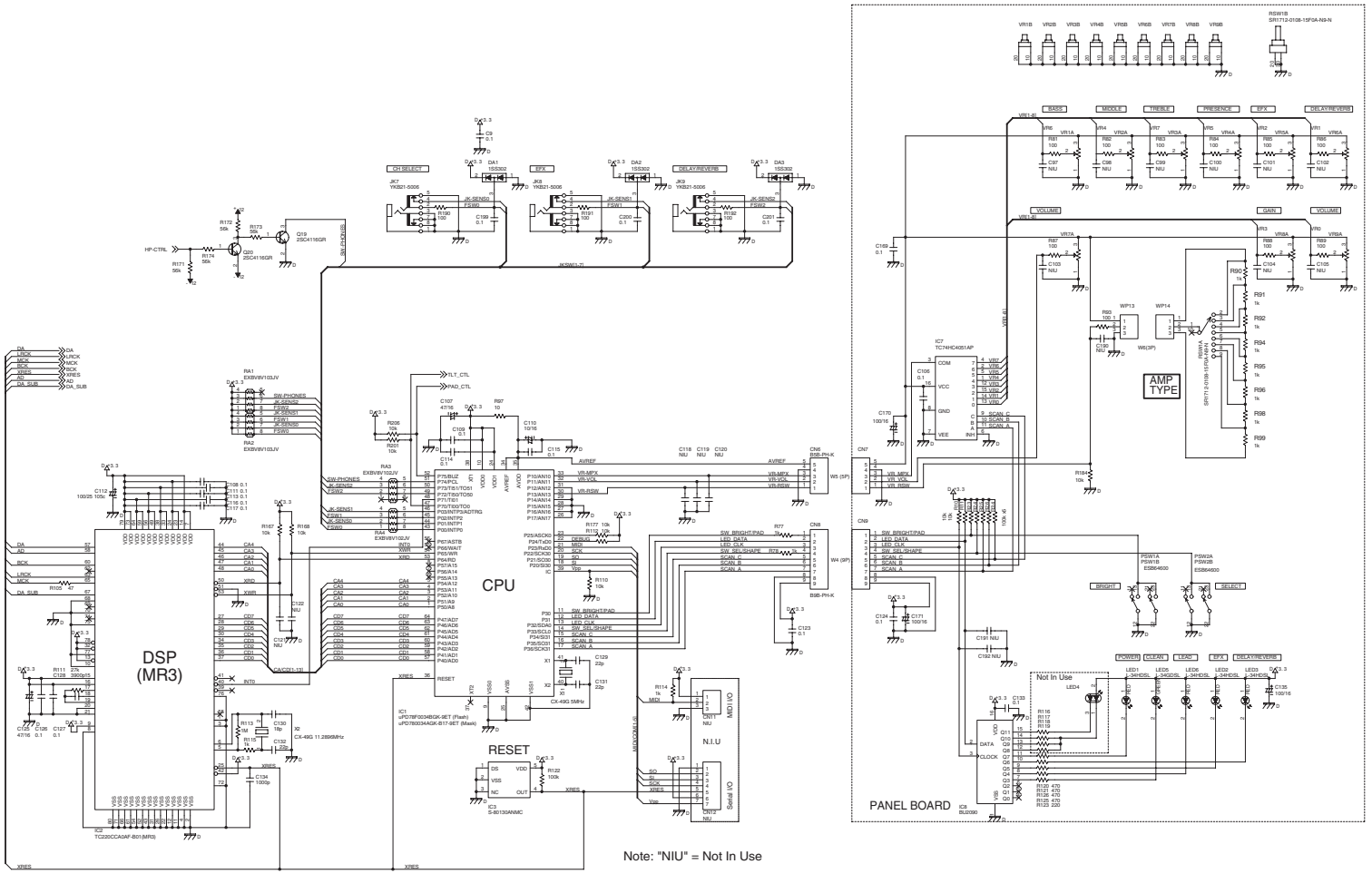

CIRCUIT DIAGRAM(MAIN BOARD ANALOG)

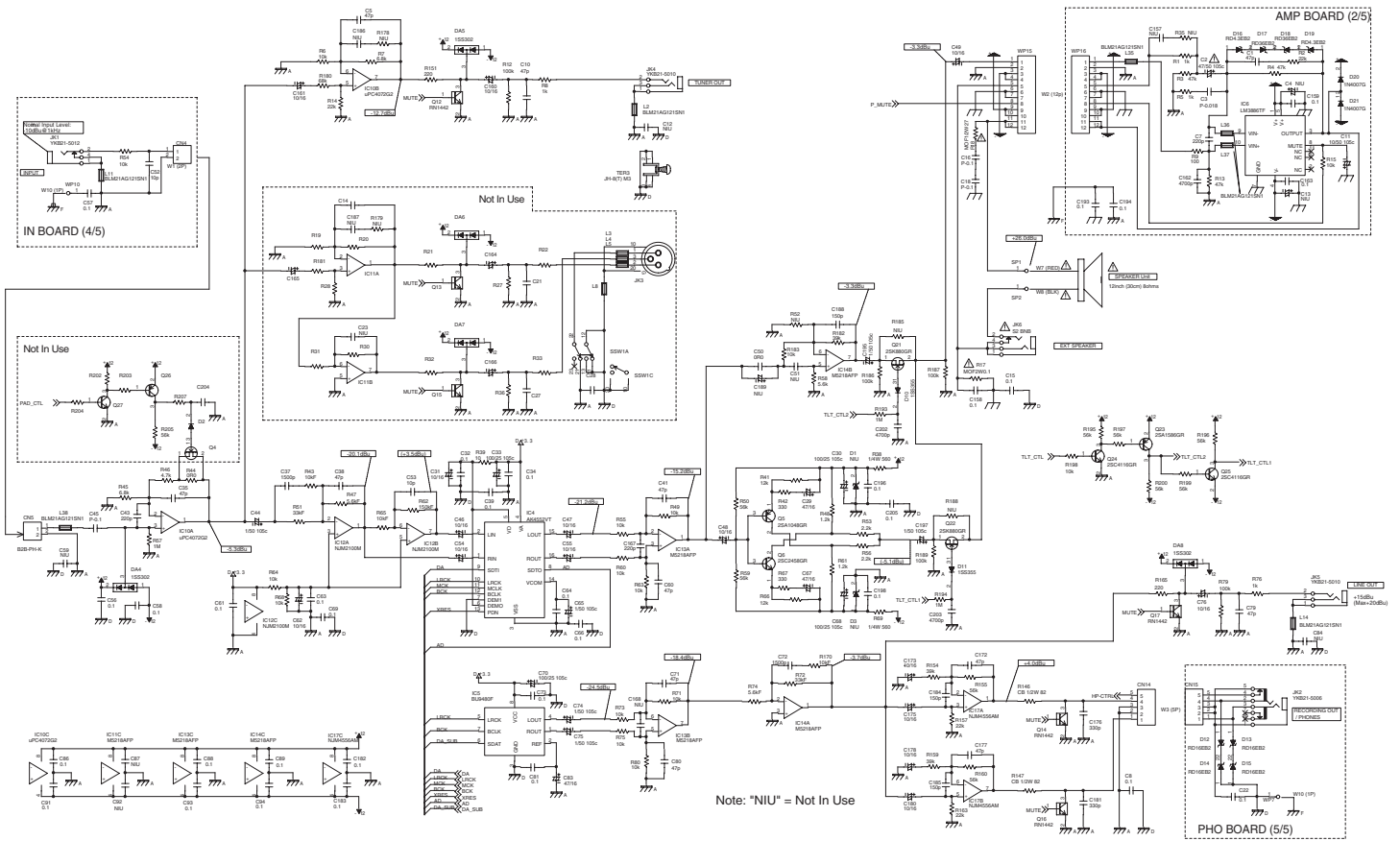

CIRCUIT DIAGRAM(MAIN BOARD POWER SUPPLY)

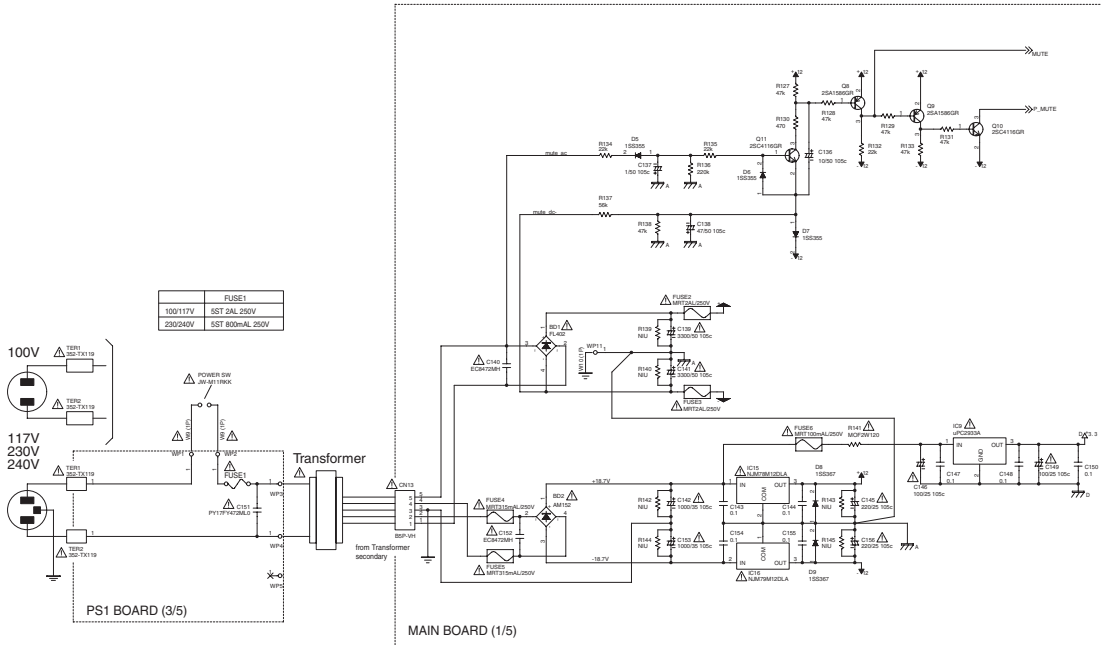

Note: *NIU* = Not In Use

