

**RANGE**

CH 2 ME605

|   |
|---|
| 1 |
| 2 |
| 3 |
| 4 |

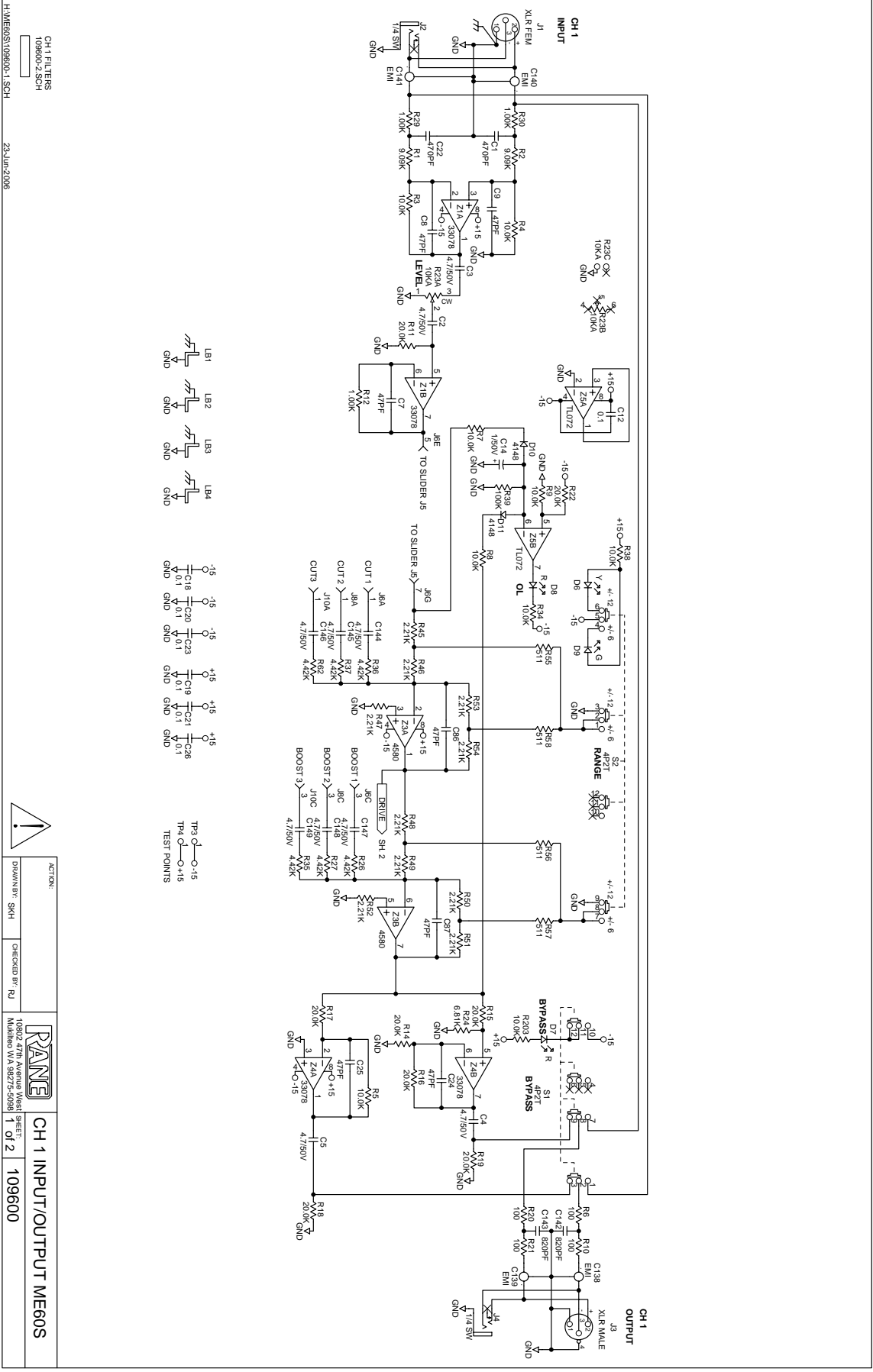



CH 1 FILTERS  
109600.2.SCH

23 JUN 2008



|         |               |                |
|---------|---------------|----------------|
| ACTION: | DRAWN BY: SKH | CHECKED BY: RJ |
|---------|---------------|----------------|



10802 4TH AVENUE WASH SHEET  
NUMBER 174 582 9 508 1 01 2 109600

CH 1 INPUT/OUTPUT ME605

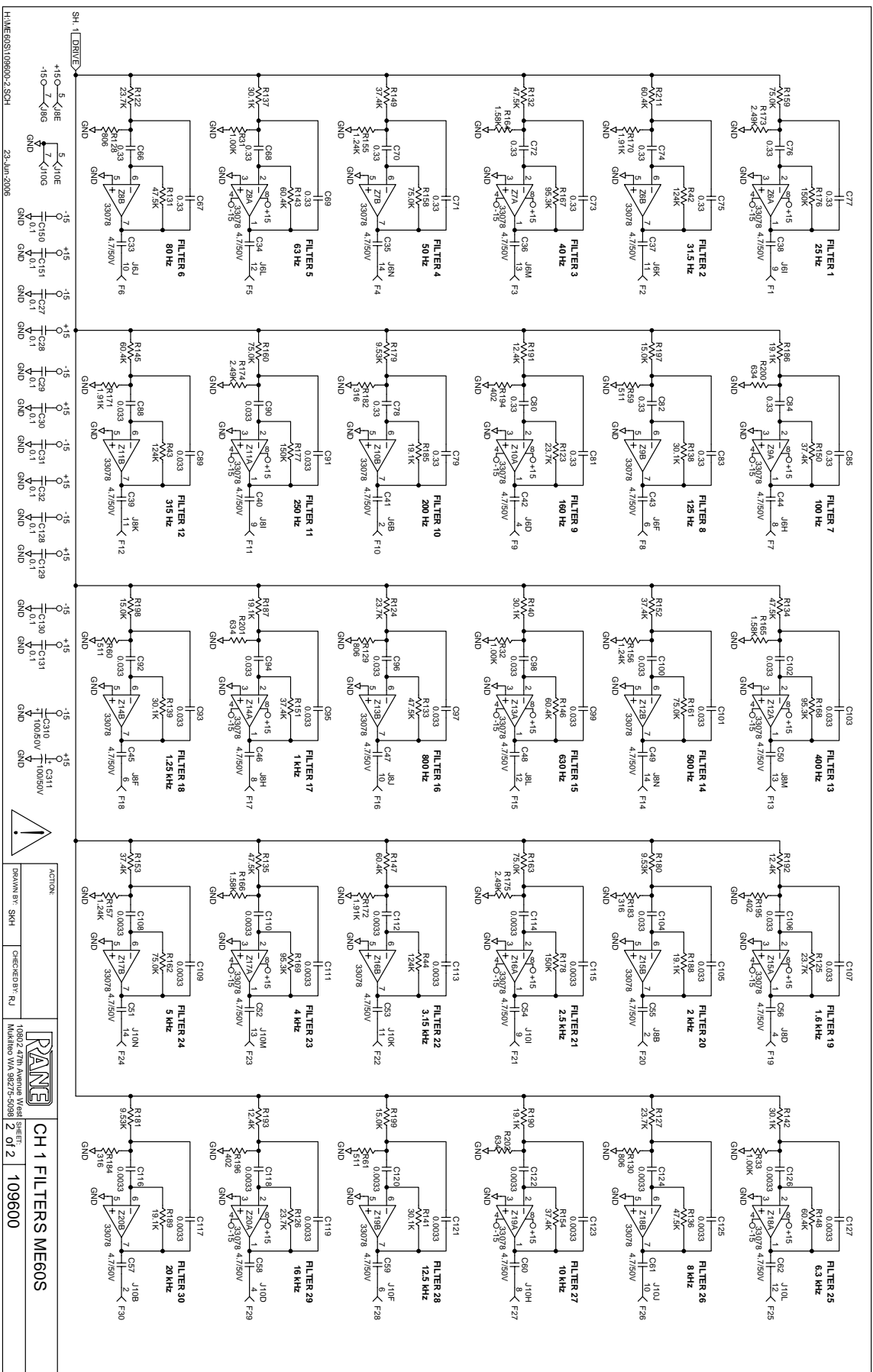

H:\MERCOS\1096002\SCH1 23-Jun-2008

ACTION:  
DRAWN BY: SKH  
CHECKED BY: RJ

10962Z 4TH AVIATION YEARS SHEET  
MEMPHIS VA 5812/25088  
2 01 2 109600

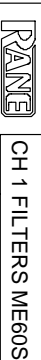

CH 1 FILTERS MEGOS

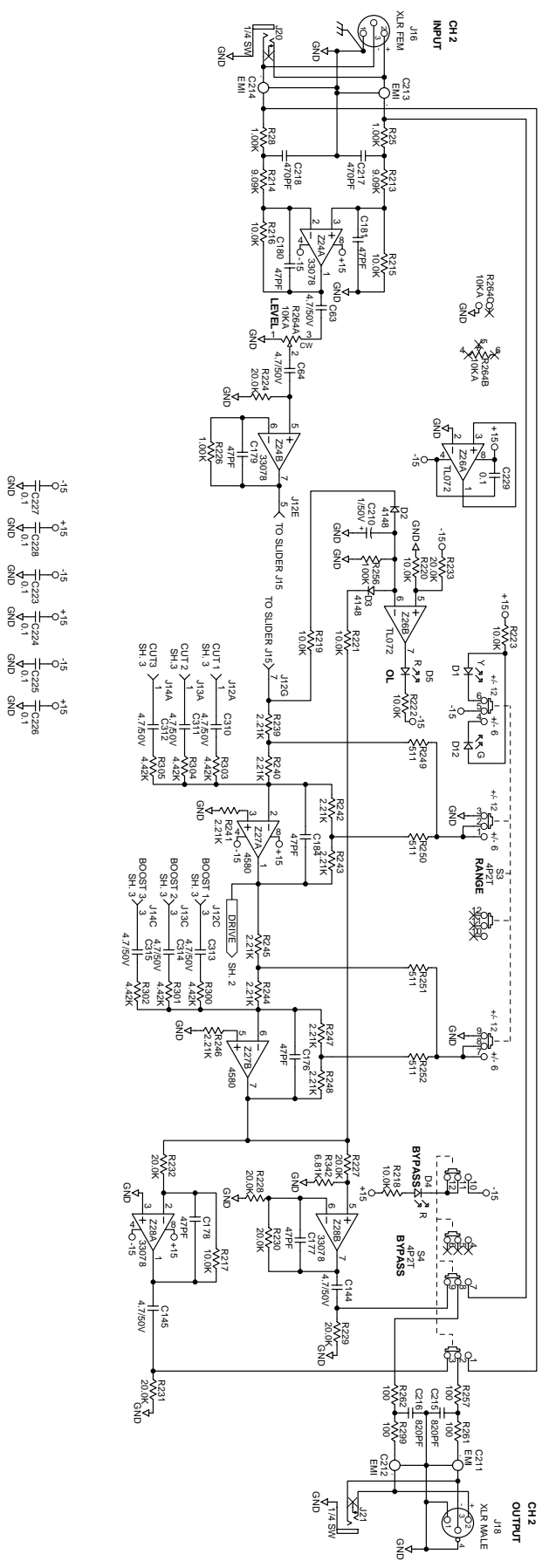

|   |                     |                      |   |                                       |
|---|---------------------|----------------------|---|---------------------------------------|
| <p>ACTIVE DELETED R226 C06<br/>                 Z27 WAS 30078 R219 WAS HOOKED<br/>                 TO J12 21JUN06 SMH</p> | <p>DRAWN BY SMH</p> | <p>CHECKED BY RJ</p> | <p>11802 47th Avenue West<br/>                 MARIETTA GA 30067-5081</p> | <p><b>CH 2 INPUT/OUTPUT ME60S</b></p> |
| <p>  </p>                              |                     |                      | <p><b>RANE</b></p>  | <p>SHEET 1 OF 3</p>                   |
| <p>109601-1</p>   |                     |                      | <p>109601-1</p>   | <p>109601</p>                         |

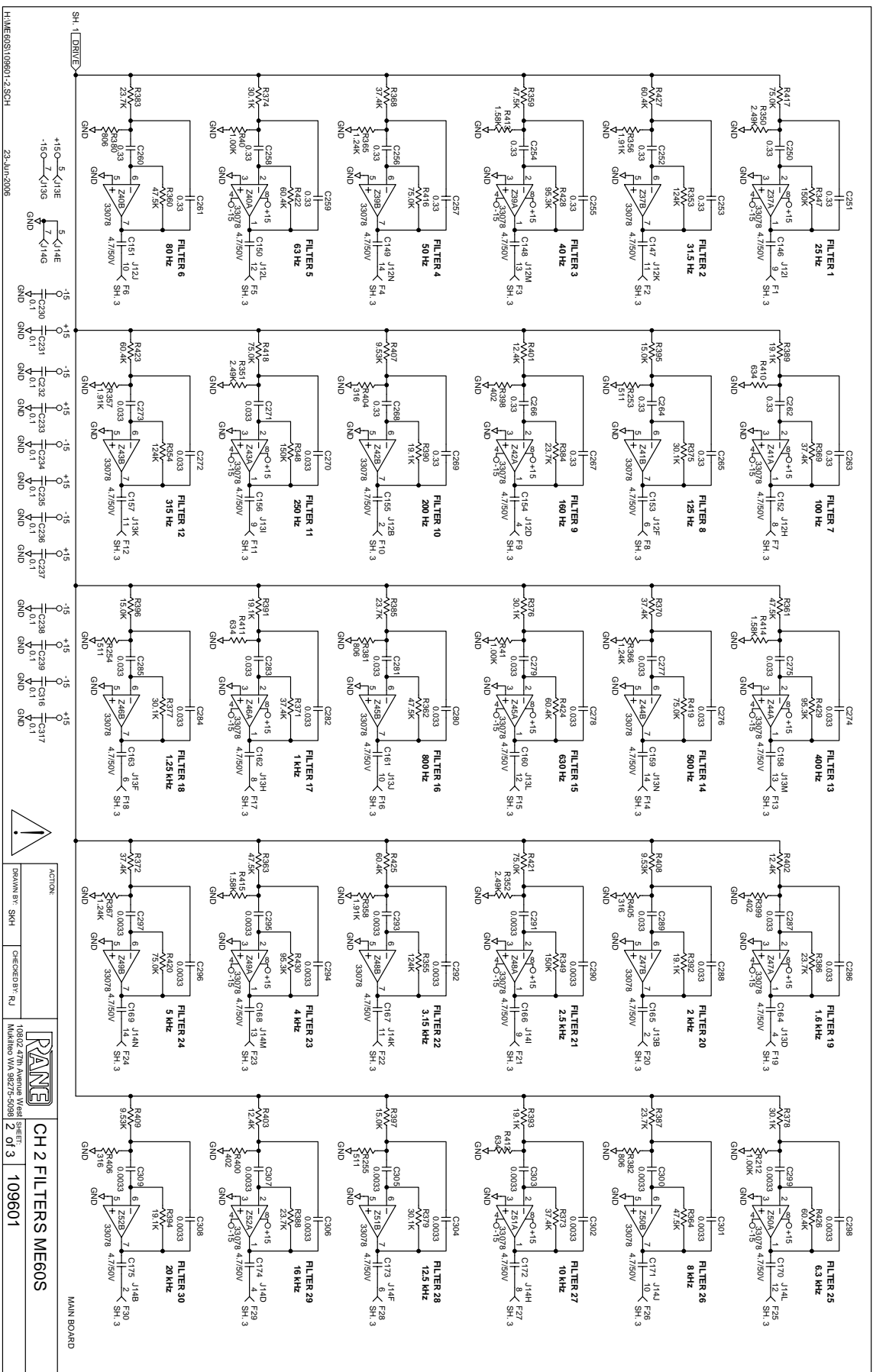

HWME60S109601-2-SCH 23-Jun-2008



ACTION:  
 DRAWN BY: SKH  
 CHECKED BY: RJ

**PARTEC**  
 10850 ZETA AVENUE  
 SUITE 100  
 MANASSAS, VA 20108-2908

**CH 2 FILTERS MEGOS**

2 of 3 109601

MAIN BOARD





