

Rane Corp. (425)355-6000  
 102866 DES FRT/REAR/AUX MM 8z  
 ACTION: ADDED C84, C85 AND R85 RJJ 11MAY99

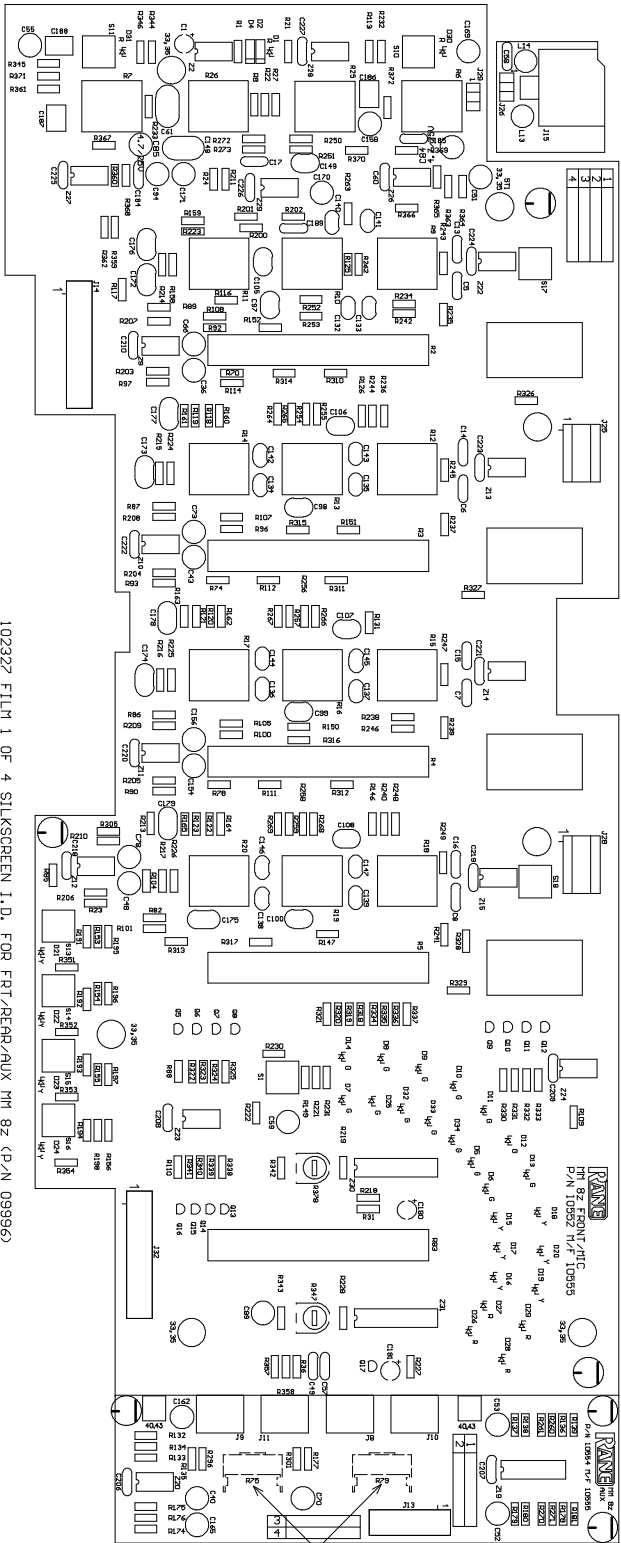

102327 FILM 1 OF 4 SILKSCREEN I.D. FOR FRT/REAR/AUX MM 8z (P/N 09996)

\*\*\*NOTICE\*\*\*  
 C84 & R85  
 REAR SIDE  
 CIRCUIT SIDE

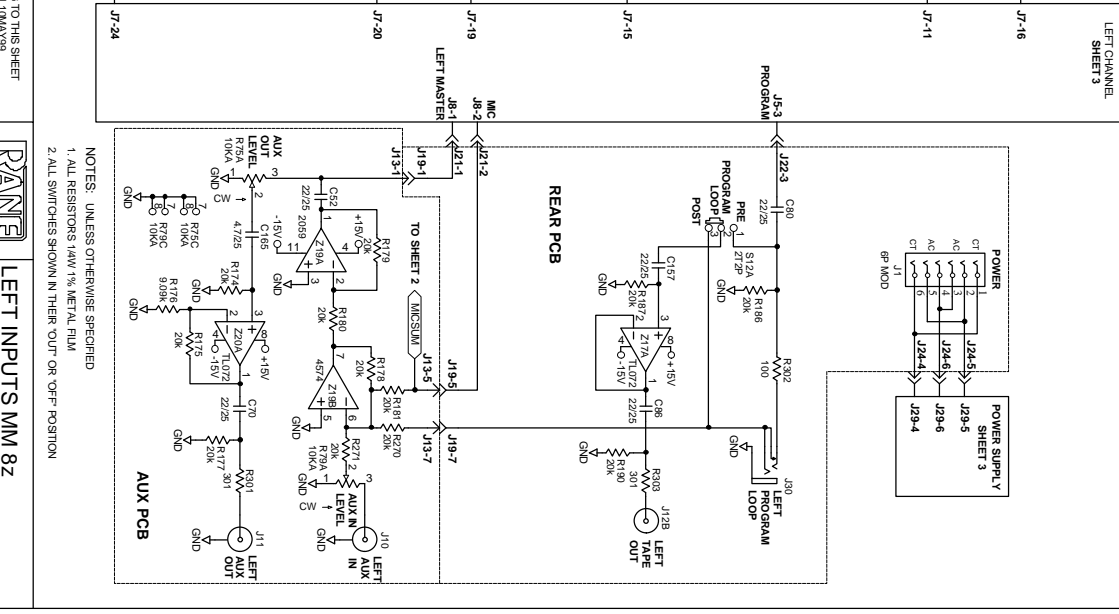
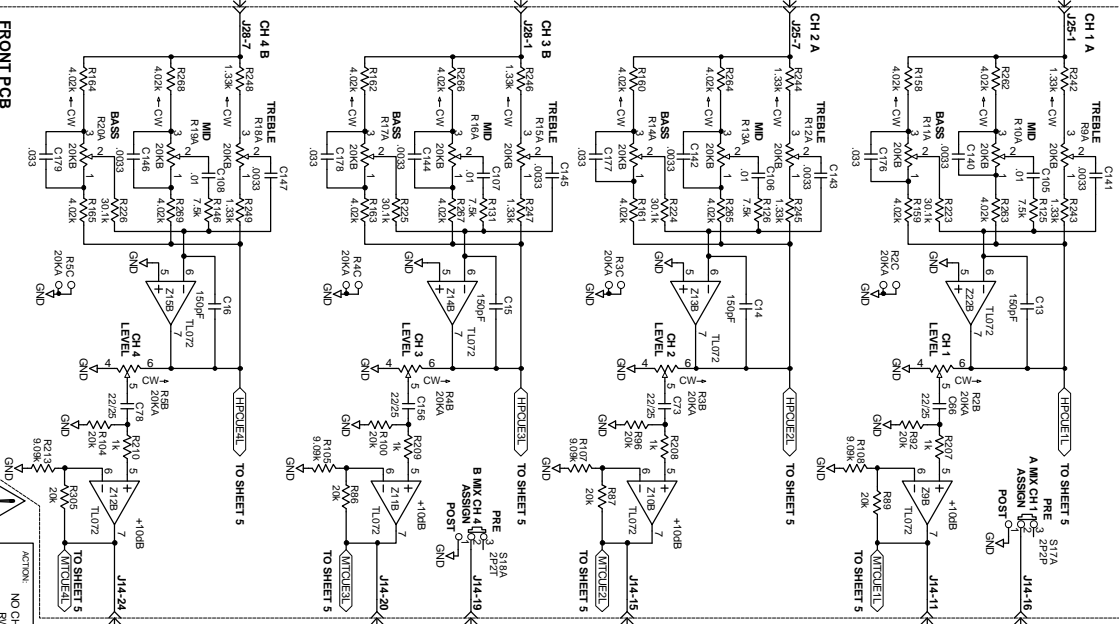
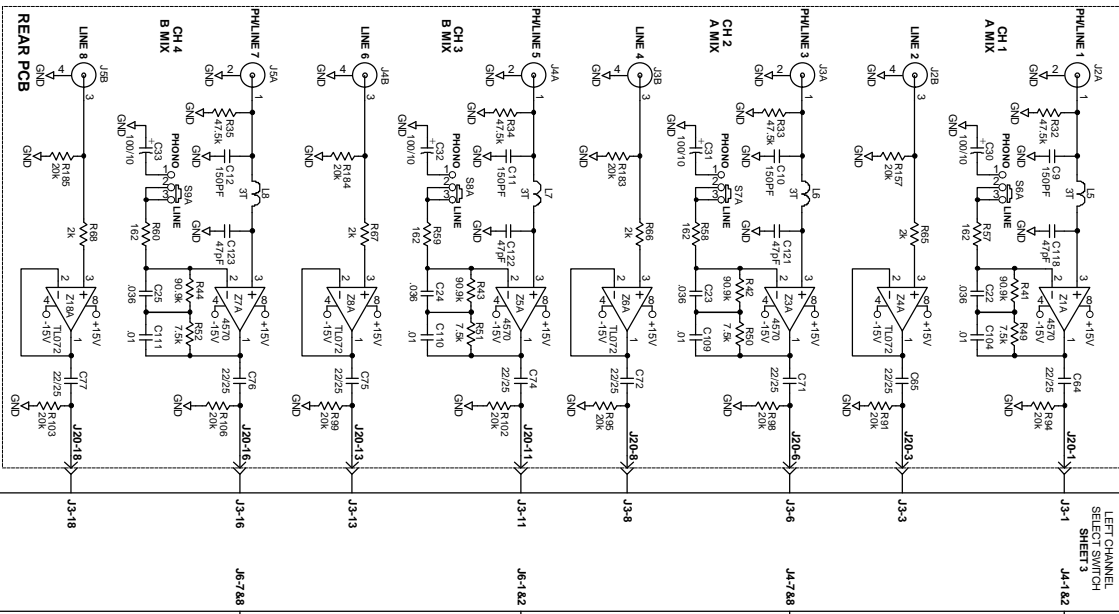

NOTES: UNLESS OTHERWISE SPECIFIED  
 1. ALL RESISTORS HAVE 1% METAL FILM  
 2. ALL SWITCHES SHOWN IN THEIR 'OUT' OR 'OFF' POSITION

NO CHG TO THIS SHEET  
 ACTION: REV: 10/04/99  
 DRAWN BY: SHH  
 CHECKED BY: RJ

102870\_1.SCH  
 SHEET 1 OF 5  
 102870

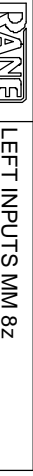

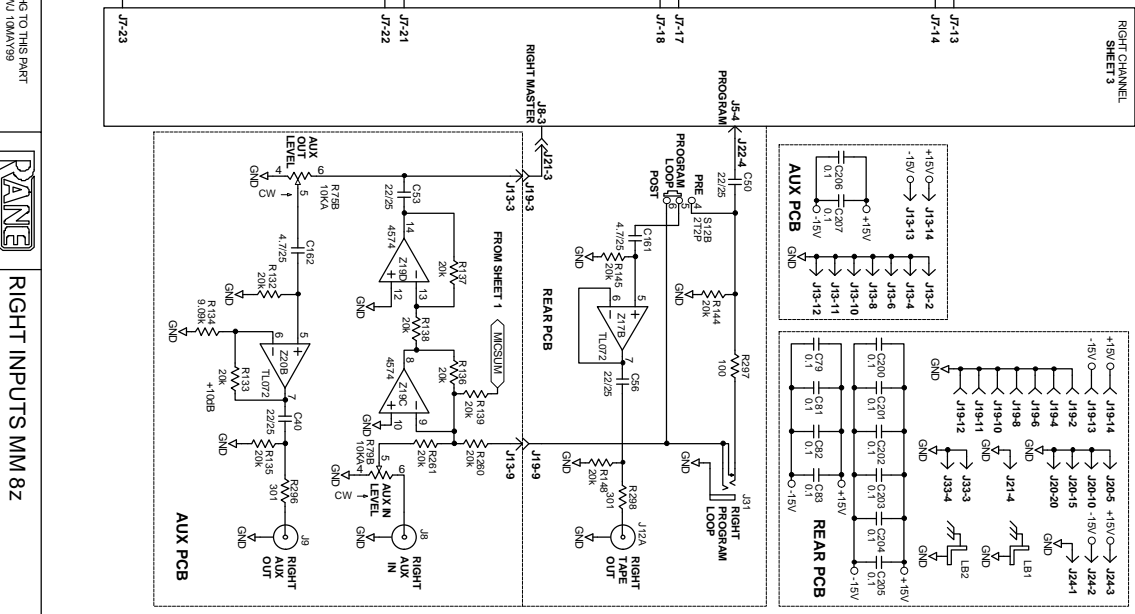
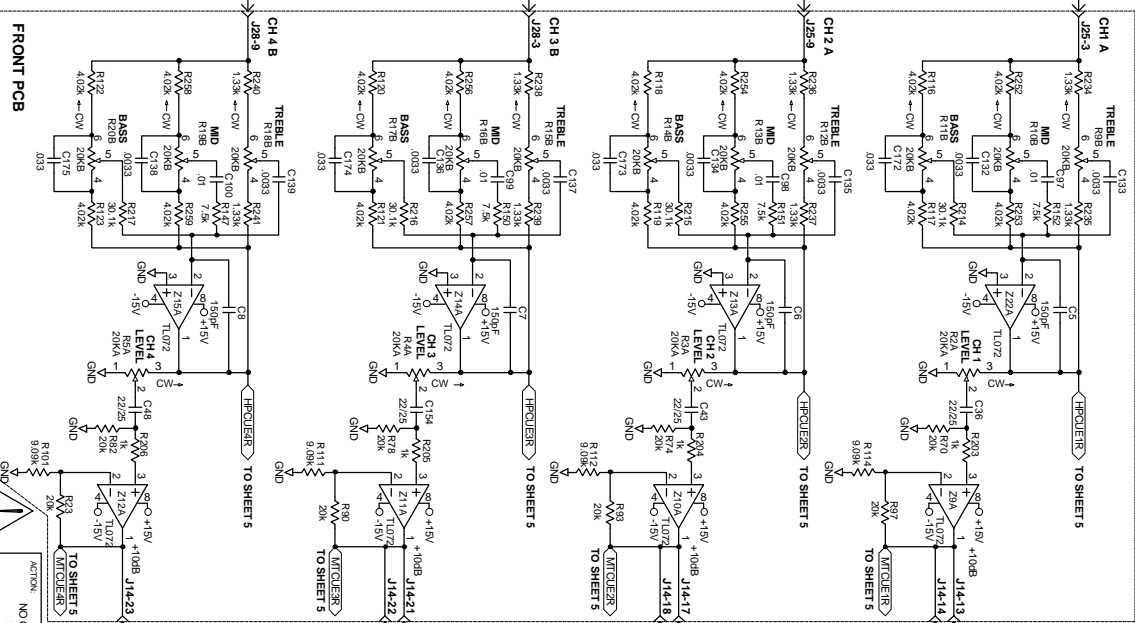
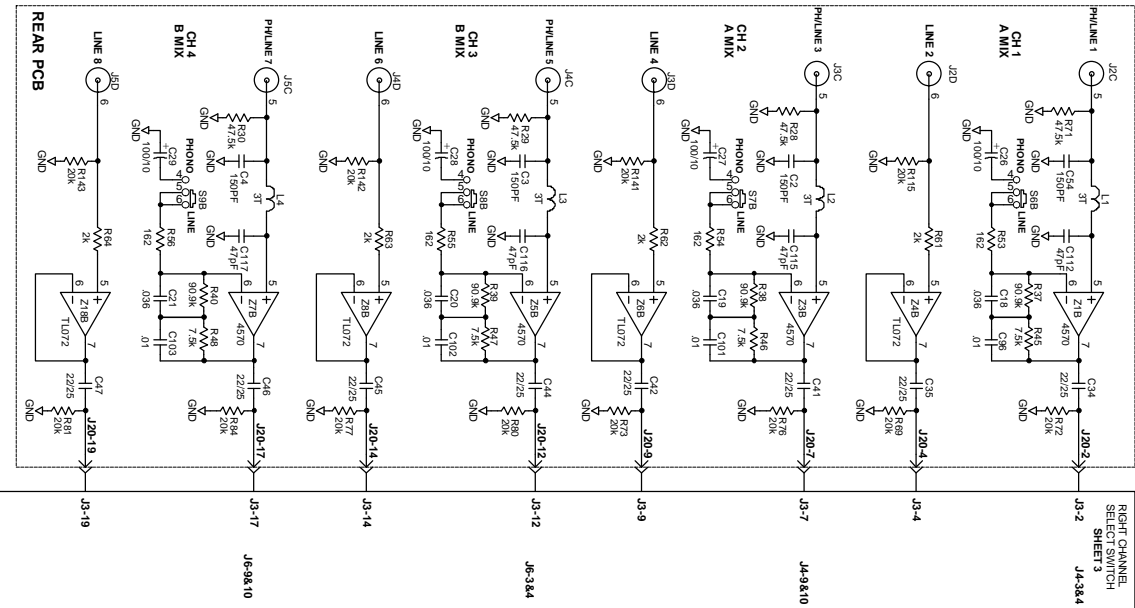

NO CHG TO THIS PART  
DRAWN BY: SKH  
CHECKED BY: RJ



RIGHT INPUTS MM 8Z  
2 of 5  
102870

1000 4th Street  
Makenna, VA 28675-5088

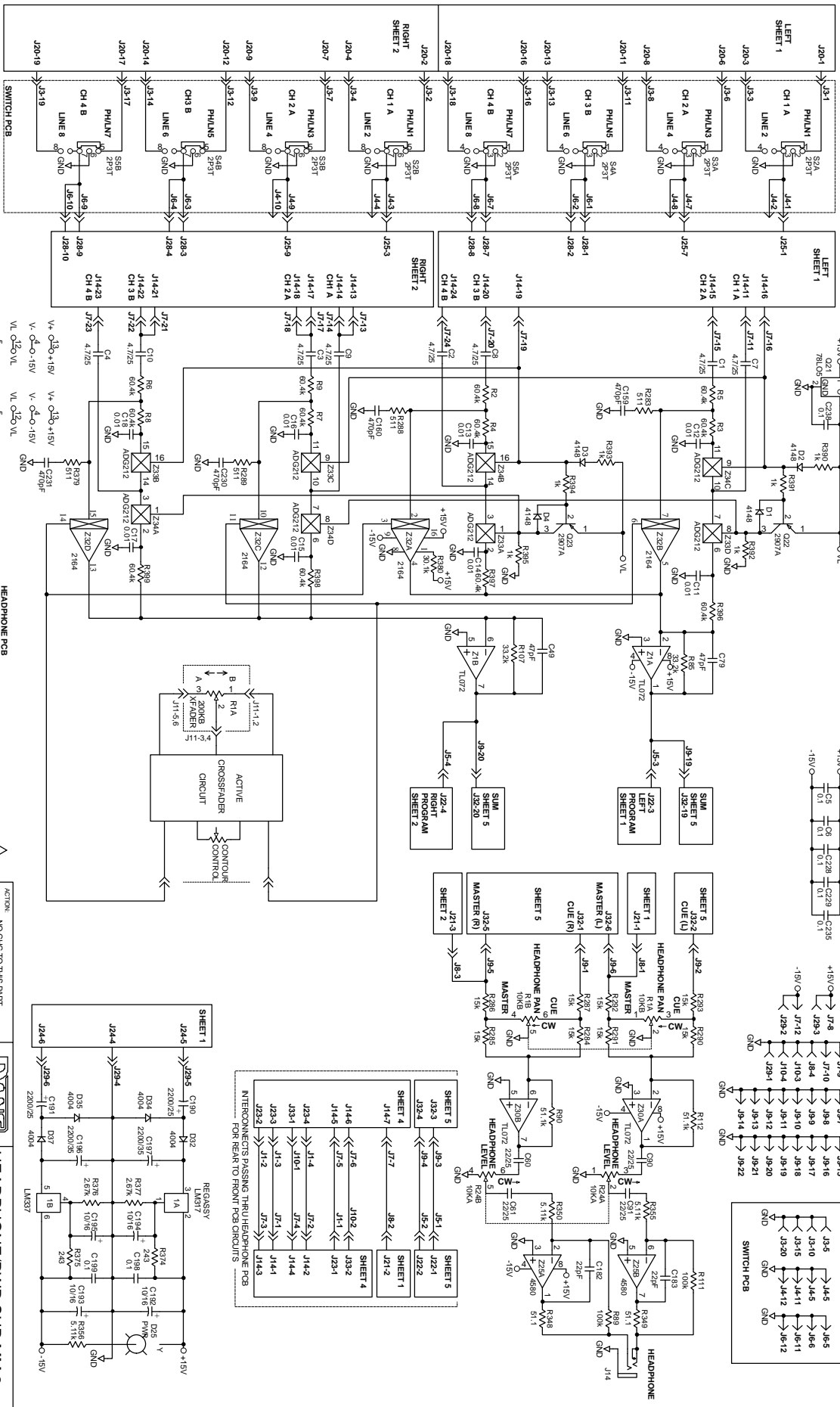

**ACTIVE CROSSFADE CONTROL**

NO CHG TO THIS PART  
DRAWN BY: SKH  
CHECKED BY: RJ

**REGASSY**  
LM317

**HEADPHONE/PWR SUP MM 8Z**  
SHEET 3 OF 5  
102870

DATE: 22/01/99  
MATERIALS: 1000000000  
MARKING: V/A 98275-5088





