

### Caractéristiques générales et particularités.

Superhétérodyne à sept lampes, une valve et un indicateur d'accord par œil magique. Le récepteur fonctionne sur alternatif de 110 à 240 volts et reçoit les trois gammes suivantes :

- O.C. — 18 à 6 MHz.
- P.O. — 1720 à 550 kHz.
- G.O. — 400 à 150 kHz.

La première lampe est une amplifiatrice H.F., penthode 6K7.

Le changement de fréquence se fait à l'aide de deux lampes : oscillatrice séparée 6J7 et modulatrice 6L7. A remarquer le montage un peu spécial de l'oscillateur. Pour les gammes O.C. et P.O. l'oscillateur est monté en *electron-coupled*; pour la gamme G.O., l'enroulement de réaction est inséré dans le circuit

plaque. En somme, la 6J7 fonctionne en triode pour les gammes P.O. et O.C., et en penthode pour la gamme G.O.

Les bobinages sont complètement séparés pour chaque gamme, aussi bien pour l'oscillateur que pour les éléments d'accord et de liaison H.F. D'autre part, des court-circuits sont prévus pour les bobinages hors service. Ainsi, pour la réception des O.C., les enroulements P.O. sont court-circuités, tandis que pour la réception des P.O., les G.O. sont court-circuités.

L'amplificatrice M.F. est encore une 6K7, et les deux transformateurs M.F. sont à sélectivité fixe.

La détection se fait à l'aide d'une double-diode 6H6, dont l'un des éléments est utilisé pour obtenir la polarisation de repos des lampes 6K7 et 6L7, dont les cathodes sont

réunies à la masse, et aussi pour obtenir les tensions d'antifading. Le montage de la diode antifading est le suivant : la plaque est réunie à la masse par une résistance de charge de valeur élevée, et la résistance de charge de détection. La cathode, par contre, est reliée à un point à faible potentiel négatif par rapport à la masse, ce point étant pris sur un pont de deux résistances inséré entre le point milieu de l'enroulement H.T. et la masse. Ainsi, en absence de signal, la diode « débite » et la ligne antifading transmet aux grilles des lampes commandées une tension négative égale à la polarisation négative appliquée à la cathode, c'est-à-dire environ — 3 volts. Lorsqu'un signal arrive, il développe le long de la résistance de charge de détection, une chute de tension négative par rapport à la masse. Lorsque

cette chute de tension dépasse — 3 volts, le potentiel de la ligne antifading varie et transmet ces variations aux grilles commandées.

La tension pour la grille de l'indicateur visuel est prise sur un pont de deux fois 2,2 M $\Omega$ , monté en parallèle sur la résistance de charge de détection.

Le potentiomètre de commande de volume est à prise intermédiaire (correction de tonalité). Dans la liaison entre la préamplificatrice 6F5 et la lampe finale 6F6, nous voyons deux condensateurs en série (10.000 em et 1.120 em). Celui de 1.120 em est court-circuité en P.O. et G.O.

Le pick-up comporte un filtre spécial pour atténuer le bruit d'aiguille et corriger la tonalité.

Les transformateurs M.F. sont accordés sur 460 kHz.

## CATHODE-RAY ALIGNMENT

## Equipment

A standard source of the specified alignment frequencies is required. Such a source should consist of an RCA Full Range Oscillator, Stock No. 9595. Output indication should be by means of an RCA Stock No. 9545 Cathode-Ray Oscillograph. An RCA Stock No. 9558 Frequency Modulator will be needed to sweep the generated signal and synchronize it with the Oscillograph in order to make possible the visual representation of the resonant characteristic of the circuit being tuned on the cathode-ray fluorescent screen.

## I-F Trimmer Adjustments

The four trimmers of the two i-f transformers are located as shown by Figure 5. Each must be aligned to a basic frequency of 460 kc. The last transformer must be aligned firstly and the first transformer aligned secondly. For such a process, it is necessary to feed the output of the Full-Range Oscillator to the stages in their order of alignment, adjusting the trimmers of each transformer and observing the effect at the second detector output on the Cathode-Ray Oscillograph. The proper point of connection of the Oscillograph is with its vertical "high" input terminal attached to the junction of R-7, R8 and R9 as illustrated in Figure 5, and with the "0" or ground terminal to the chassis. The "Ext. Sync." terminals of the Oscillograph should be connected to the Frequency Modulator as shown by Figure 4. A .001 mfd. capacitor installed in series with the Oscillator "Ant." lead will prevent the voltages of the stage under alignment from becoming upset. The vertical "A" amplifier should be "C.N." for the ensuing adjustments and the gain control kept at its maximum position. For each adjustment, the Oscillator output need be regulated so that the image obtained on the Oscillograph screen will be of sufficient size as to be accurately observable. Proceed further as follows:

- (a) Place the receiver, Oscillograph and test Oscillator in operation. Set the receiver range switch to Band "A" and tune the station selector to a point where no interference will be picked up, shorting the antenna and ground terminals if necessary. Set the Oscillograph horizontal "B" amplifier to "Timing" and control its gain so that the luminescent spot sweeps a straight line trace completely across the screen. Place the timing control to "Int." Adjust the intensity and focusing controls of the Oscillograph to produce the correct size and strength of the spot.
- (b) Attach the output of the test Oscillator between the control grid cap of the RCA-6L7 i-f tube and chassis ground as shown typically by Figure 4. Tune the Oscillator to 460 kc. and set its modulation switch to "On". Regulate its output until the signal produces a wave pattern on the Oscillograph screen, adjusting the Oscillograph controls to give the desired number of cycles. Cause the image to stand still on the screen by manipulation of the frequency and synchronizing controls. Then carefully tune the two trimmers C-29 and C-30 of the second i-f transformer to produce maximum amplitude (vertical deflection) of the oscillographic image. Under this condition the transformer will be sharply resonated to 460 kc.
- (c) The Frequency Modulator should then be placed in operation and interconnected with the Full-Range Oscillator by means of the special shielded patch cord. Figure 4 shows the proper arrangement. Set the Frequency Modulator sweep range switch to its "Lo" position and turn the Oscillator modulation switch to "Off". Change the timing control of the Oscillograph to "Ext." and place the range switch to its No. 2 position. Then carefully shift the tuning of the Oscillator so as to increase its frequency, until two distinct and similar waves appear on the Oscillograph screen and become exactly coincident at their highest points. These curves will be found to occur at an Oscillator setting of approximately 740 kc. They will be identical in

shape but appearing in reversed positions. Adjust the frequency control of the Oscillograph in order to cause the waves to conform with the above requirements and to make them remain motionless on the screen. This will require a setting of approximately  $\frac{1}{2}$  clockwise rotation of the frequency control. The trimmers C-29 and C-30 should then be re-adjusted so that the two curves move together and become exactly coincident throughout their lengths, maintaining the maximum amplitude at which this condition can be brought about.

- (d) Leaving the equipment connected and adjusted as in (c), change the Oscillator output to the control-grid cap of the RCA-6L7 first-detector tube. Then adjust the first i-f transformer trimmers C-24 and C-25 so that the forward and reverse waves appearing on the Oscillograph coincide throughout their lengths and have maximum amplitude. The shape of the composite wave obtained from this operation is a true representation of the overall tuning characteristic of the i-f system. Each trimmer of the entire group should then be checked to assure that it is in correct alignment as indicated by the degree of coincidence and relative amplitude of the image on the Oscillograph screen.

## R-F Trimmer Adjustments

Locations of the various antenna, detector and oscillator coil trimmers are shown by Figure 5. The test Oscillator should be removed from connection with the i-f system and its output connected to the antenna-ground terminals of the receiver. No changes are to be made in the connections of the Oscillograph at the second detector. During the following adjustments, the Oscillator output should be regulated as often as is necessary to keep the oscillographic image as low as is practically observable. Adherence to such a procedure will obviate the broadness of tuning that would result from a.v.c. action on a stronger signal. Proceed with the adjustments as follows:

## Calibration

Set the receiver range switch to Band A and rotate the station selector until the tuning condenser plates are in *full mesh* (maximum capacitance). Then move the main dial pointer until it points exactly to the *horizontal* line at the low frequency end of the Band A scale.

## Band A

- (a) With the receiver range switch in its Band A position, tune the station selector until the dial pointer is at a reading of 1,720 kc. Adjust the test Oscillator to 1,720 kc. (modulation "On" and Frequency Modulator disconnected) and increase its output to produce a registration on the Oscillograph. Carefully align the oscillator, detector, and antenna trimmers C-20, C-10 and C-3 respectively, so that each brings about maximum amplitude of output as shown by the wave on the Oscillograph. It will be necessary to have the timing control of the Oscillograph on "Int." for this operation. After each trimmer has been peaked, the Oscillograph timing control should be set to "Ext." and the Frequency Modulator placed into operation with its connections to the Oscillator and Oscillograph made in accordance with Figure 4. Turn the modulation switch of the Oscillator to "Off" and retune the Oscillator (increase frequency) until the forward and reverse waves show on the Oscillograph and become coincident at their highest points. Adjust the trimmers C-20, C-10 and C-3 again, setting each to the point which produces the best coincidence and maximum amplitude of the wave images.
- (b) Remove the Frequency Modulator cable from the Oscillator and shift the signal frequency to 600 kc. Place the modulation switch to "On". Tune the receiver to pick up this signal, disregarding the dial reading at which it is best received. Then insert the Frequency Modulator plug and retune the Oscillator (modula-

tion "Off") until the two similar forward and reverse waves appear on the screen. For this adjustment, it is advisable to shift the Oscillator to its 200-400 kc. range and use the third harmonic of the generated signal in order to obtain the desired range of sweep. The oscillator series trimmer C-19 should then be adjusted to produce maximum amplitude of the images. No rocking will be necessary on the station selector inasmuch as the signal frequency is being "wobbled" by the Frequency Modulator to produce the same effect.

After completing this adjustment, the trimmer C-20 should be realigned as in (a) to correct for any change brought about by the adjustment of C-19.

## Band X

- (a) Disconnect the Frequency Modulator and tune the test Oscillator to a frequency of 400 kc. (Modulation "On"). Place the receiver range switch to its Band X position and tune the station selector until the dial pointer reads exactly 400 kc. Adjust the Oscillograph timing control to "Int." Then align each of the trimmers C-18, C-9 and C-2 to the point producing maximum output on the Oscillograph. Place the Frequency Modulator in operation and attach it to the test Oscillator by means of the shielded cable. Change the Oscillograph timing to "Ext." Increase the frequency of the Oscillator (Modulation "Off") until the two forward and reverse waves appear and become coincident at their highest point, approximately at 462 kc. These waves may be made to remain stationary on the screen by manipulation of the Oscillograph range switch (No. 2 position) and frequency control (mid-position). Readjust the three trimmers C-18, C-9 and C-2 to give maximum amplitude and complete coincidence of the waves.
- (b) Change the test Oscillator so that it delivers a signal of 150 kc. with the Frequency Modulator disconnected. Tune this signal on the receiver, which should be set to the Band X setting, disregarding the dial reading at which the signal is best received. Then interconnect the Frequency Modulator with the Oscillator and retune the latter to the point at which the two similar waves appear on the screen. Adjust the trimmer C-47 for maximum amplitude of the wave images. Rocking of the tuning condenser will not be necessary for this operation as such is duplicated by the Frequency Modulator. Repeat the alignment of C-18 as in (a) to correct for any error brought about by the adjustment of C-47.

## Band C

- (a) Turn the range switch of the receiver to its Band C position and tune the station selector until the dial pointer reads 18,000 kc. Set the test Oscillator to 18,000 kc. (modulation "On" and Frequency Modulator disconnected) and regulate its output to the level required for convenient observation. Adjust the trimmer C-16 to the point producing maximum output as indicated on the Oscillograph. Check for the presence of the proper "image" signal by tuning the receiver to 17,080 kc. The 18,000 kc. signal of the Oscillator will be received at this point if the adjustment of C-16 has been properly made using the position of least capacitance which gives maximum receiver output. It may be necessary to increase the output of the Oscillator in order to get an indication of the "image". No adjustments should be made during this check.
- (b) Return the receiver tuning to 18,000 kc., realign C-16 if necessary, and then adjust the detector and antenna trimmers, C-8 and C-1, for maximum signal output as evidenced by the oscillographic image. No further adjustments are to be made on this band.

## OUTPUT INDICATOR ALIGNMENT

To align the receiver by means of an output indicator other than a Cathode-Ray Oscillograph will require the use of a standard test Oscillator such as that recommended above for the source of signals and means of indication for the output. The RCA Neon Output Indicator, Stock No. 4317 will be found very satisfactory for such use. It should be connected across the voice coil circuit of the loudspeaker or across the output transformer primary.

## I-F Alignment

Connect the test Oscillator to the control-grid cap of the i-f tube. Advance the volume control of the receiver to its full-on position. Tune the test Oscillator to 460 kc. and align the trimmers C-29 and C-30 to give maximum receiver output. Regulate the Oscillator output during this adjustment so that the output indication is as small as can be conveniently observed. After completing the adjustments of these trimmers, reconnect the Oscillator so that it will feed into the control-grid circuit of the RCA-6L7 first-detector. Then tune the first i-f transformer trimmers C-24 and C-25 for maximum receiver output.

## R-F Alignment

After completing the i-f adjustments, it is advisable to correct the line-up of the circuits ahead of the first detector. The test Oscillator should be connected to the antenna-ground terminals of the receiver and the manual volume control kept at its maximum position. For each adjustment the Oscillator output should be maintained as low as possible in order to avoid broadness of tuning which would result from a.v.c. action on a stronger signal. Band A should be aligned by supplying a 1,720 kc. signal to the receiver, tuning the station selector to a dial reading of 1,720 and adjusting the trimmers C-20, C-10 and C-3 to produce maximum receiver output. The Oscillator should then be shifted to 600 kc. and the receiver tuned to resonate this signal, disregarding the reading at which it is best received. Trimmer C-19 must then be adjusted, simultaneously while rocking the station selector backward and forward through the signal until the maximum output results from the combined operations. C-20 should be rechecked to assure that its adjustment has not changed because of the trimming of C-19. Band X must be aligned at 400 kc. and 150 kc. Tune the test Oscillator to 400 kc. and turn the receiver dial to the same reading. Adjust trimmers C-18, C-9 and C-2 for maximum (peak) receiver output. Then shift the Oscillator to 150 kc. and tune the receiver to pick up this signal, disregarding the dial reading at which it is best received. Adjust trimmer C-47, simultaneously rocking the tuning condenser backward and forward through the signal, until maximum receiver output results from the combined operations. Repeat the alignment of C-18 as above to correct for any change which may have been caused by the adjustment of C-47. Change the receiver so that it is operative and the dial reads 18,000 kc. on the "C" Band. Tune the test Oscillator to 18,000 kc. Then adjust the oscillator trimmer C-16 to produce maximum (peak) output. Two positions of this trimmer will be found which conform with this requirement. The one of least capacitance is correct. Check for the presence of "image" response at 17,080 kc. by shifting the receiver tuning. If it is received at such a point, the trimmer C-16 has been correctly adjusted to the right peak. No adjustments are to be made during this check. Tune the receiver back to the 18,000 kc. dial marking, readjust C-16 if necessary, and then tune the detector and antenna capacitors C-1 and C-8 for maximum receiver output. No further adjustments are necessary.

## CENTERING ARMATURE

Refer to Figure 10 showing the pickup inner structure. The armature is shown in its proper relation to the magnet pole pieces, i. e., exactly centered. Whenever this centering adjustment has been disturbed, the screws A, B, and C should be loosened and the armature clamp adjusted to the point where the vertical axis of the armature is at right angles to the horizontal axis of the pole pieces, and centered between them. This centering operation may be facilitated by inserting a small rod or nail into the armature needle hole, using it as a lever to test the angular movement of the armature. The limitation of the

movement in each direction will be caused by the armature striking the pole pieces. The proper adjustment is obtained when there is equal angular displacement of the armature and adjustment rod or nail to each side of the vertical axis of the magnet and coil assembly. The screws A and B should then be secured, observing care not to disturb the adjustment of the armature clamp. Then place the pickup in a vise and secure the centering spring-clamp by means of the screw C, allowing the centering spring to remain in the position at which the armature is exactly centered between the pole pieces. With a little practice, the correct adjustment of the armature may be readily obtained. The air gap between the pole pieces and the armature should be kept free from dust, filings, and other such foreign materials which would obstruct the movement of the pickup armature.

## DAMPING BLOCK

The viscoloid block which is attached to the back end of the armature shank serves as a mechanical filter to eliminate undesirable resonances and to cause the frequency response to be uniform. Should it be necessary to replace this damping block, it may be done by removing screw D and the cover support bracket from the mechanism and taking off the old viscoloid block. The surface of the armature which is in contact with the viscoloid should be thoroughly cleaned with fine emery cloth. Then insert the new block so that it occupies the same position as it did originally. Make certain that the block is in correct vertical alignment with the armature. The hole in the new viscoloid block is somewhat smaller than the diameter of the armature in order to permit a snug fit. With the viscoloid aligned on the armature, screw D and the cover support bracket should then be replaced. Heat should be applied to the armature (viscoloid side) so that the viscoloid block will fuse at the point of contact and become rigidly attached to the armature. A special-tip soldering iron constructed as shown in Figure 11 will be found very useful in performing this operation. The iron should be applied only long enough to slightly melt the block and cause a small bulge on both sides.

## REPLACING COIL

Whenever there is defective operation due to an open or shorted pickup coil, this coil should be replaced. The method of replacement will be obvious upon inspection of the pickup assembly and by study of the cut-a-way illustrations. Make sure that the new coil is properly centered with the hole in the support strip and glued securely in that position. It is important to readjust the armature as previously explained after reassembly of the mechanism. Only rosin core solder should be used for soldering the coil leads in the pickup. This same type of solder should be used when necessary for soldering the centering spring to the armature.

## MAGNETIZING

Loss of magnetization will not usually occur when the pickup has received normal care due to the fact that the magnet and pole pieces are one unit and the magnetic circuit remains closed at all times. When the pickup has been mishandled, subjected to a strong a-c field, jolted, or dropped, there may be an appreciable loss of magnetic strength, in which case it will be necessary to remagnetize the entire structure. This should be done by first removing the cover and then placing the pickup assembly on the poles of a standard pickup magnetizer such as the RCA Stock No. 9549 Pickup Magnetizer and charging the pickup in accordance with the instructions accompanying the magnetizer. It is recommended that the pickup be magnetized while the armature assembly is in place. This will necessitate that one of the poles of the magnetizer be rotated 180 degrees. This will provide proper clearance for the armature clamp assembly. It is preferable to check the polarity of the pickup magnet and to remagnetize it so that the same polarity is maintained.

## General Description

The RCA Victor Model D 9-19 combination radio receiver and manual phonograph provides excellent entertainment from either broadcast reception or record reproduction. It consists of a nine-tube, three-band radio receiver, and a manual phonograph, combined in the one cabinet. The high level of sound energy obtainable from the output of this instrument is capably handled by a new sensitive, twelve-inch, electrodynamic loudspeaker. Outstanding features of this instrument are as follows:

### Magic Brain

The radio receiver includes the "Magic Brain" unit for maximum all-around efficiency. This unit is a scientifically correct co-ordination of all the parts for the r-f, oscillator, and first detector functions of a Superheterodyne Receiver. Such design of the important head end, or "Magic Brain" unit, gives greater efficiency in the short-wave ranges as all lead lengths are kept as short as possible, and all sockets and other parts are located for best possible operation.

### Magic Eye

A cathode-ray tube whose fluorescent screen has the appearance of a human eye is used for visually indicating when the receiver is accurately tuned to the incoming signal. This tube is of new design. It contains two groups of elements; one group operates as an amplifier and the other group operates as a cathode-ray tube.

The cathode-ray section consists of a conically shaped luminescent screen, a cathode, and a control electrode. The detected signal from the receiver is applied through the amplifier section of the tuning tube to the control electrode of the cathode-ray section. This control electrode, in turn, affects the electron stream emitted by the cathode in such a manner as to cause a triangular shadow on the luminescent screen. The size of the shadow caused by the control electrode is determined by the strength of the incoming signal, so that a change-of-tuning is readily exhibited on the cathode-ray screen, and therefore tuning to exact resonance can be definitely obtained.

### RCA All-Metal Tubes

The new metal tubes are used in the radio receiver for amplifying and detecting purposes. These tubes make possible a greater range of stable amplification not previously attainable with corresponding glass types. Their metal envelopes form a perfect electrostatic and electromagnetic shield, precluding the former necessity for elaborate shielding by means of cans. The metal tubes are especially adaptable to the modern, extended-range receivers because of their efficient shielding and their favorable internal characteristics.

### Phonograph Mechanism

An improved manually operated phonograph mechanism is used in this model. The 12-inch turntable will accommodate either the 10-inch or the 12-inch phonograph records. The turntable rotates at a speed of 78 r.p.m. A speed regulator is provided for accurate adjustment of this speed. The instrument may be purchased with any one of three ratings as specified under Electrical Specifications. *It is important that a machine of any particular rating be operated at the frequency and voltage for which it is rated.*

Attempts to operate at ratings other than specified for the particular instrument may result in damage to both the phonograph motor and the radio receiver. An automatic switch is provided to turn "off" the phonograph motor at the completion of record play when the eccentric-type inside groove record is used.

### Colorband Dial

An open face airplane-type of dial is used. Each scale has a band of color adjacent to its graduations and three short strips of corresponding colors at the lower part of the dial for index purposes. An index pointer, which moves as the band switch is rotated, points to one of these colors to identify the band in use. The drive mechanism is variable, there being either a 50-to-1 or 10-to-1 ratio available between the tuning knob and condenser drive shaft. The new shock-proof condenser mounting reduces microphonic tendencies to a minimum.

## CIRCUIT FEATURES

The circuit is based upon the Superheterodyne principle. The three ranges of tuning are covered by three sets of coils. A single r-f stage provides the desired selectivity and gain ahead of the hexode first-detector tube. The oscillator stage operates separately from the first detector. A single stage i-f system is employed. Its basic frequency is 460 kc. Diode detection is performed by a double diode RCA-6H6 Radiotron. Automatic volume control is provided by this same tube. The audio system consists of two stages, the driver, an RCA-6F5, and the output, an RCA-6F6. High voltages for plate, screen, and bias supplies are obtained from an RCA-5Z full-wave rectifier through an efficient filter. The field of the loudspeaker acts as a reactor in the filter circuit. Further details of the circuit are as follows:

### Oscillator

The oscillator circuit has extreme stability of frequency and good uniformity of output over the tuning ranges. These qualities assure that the tuning of the receiver will not drift as the line voltage varies. The action of the circuit is such that when the cathode emission tends to change with line voltage or because of other reasons, the variation of voltage drop in the plate and screen resistor restores the operating characteristics of the tube to normal and thus maintains constancy of the generated signal.

### First Detector

This stage has unusually good high frequency mixing efficiency. The tube used, an RCA-6L7, is a new hexode type. The signal is supplied to the first control-grid and the oscillator voltage is fed in on a second control-grid, a screen-grid separating the two. The arrangement of the grids prevents degenerative difficulties, particularly at the higher frequencies. The second grid is direct-connected to the cathode of the oscillator and has no d-c bias.

### Compensated Volume Control

The variation in response of the human ear with different degrees of volume is compensated for by a resistor and condenser network in the manual volume control circuit. The volume control itself is an acoustically tapered potentiometer which provides equal changes of sound intensity for the listener per degree of rotation.

### Range Switch

The band-change switch has several functions. It exchanges the antenna, detector, and oscillator coils in order to select the range desired. At the same time, it shorts out the unused coils so as to eliminate their absorptive effects. It also varies the fidelity by shorting a coupling condenser in the audio system to provide the desired reproduction for short-wave as well as long-wave reception.

### Tone Control

Provision is included for variable reduction of high frequencies. This consists of a resistor and condenser combination across the primary winding of the output transformer, the resistor being the variable element. As it is decreased, the high-frequency response limit is lowered.

### Power System

The power transformer has its primary winding capacitively shielded from its secondary windings to eliminate transfer of line disturbances into the receiver and to stop any tendency for the circuit to radiate into the line. Rectification is performed in the usual manner by a full-wave tube.

### Detection and A.V.C.

The modulated signal as obtained from the output of the i-f system is detected by an RCA-6H6 twin diode tube. The audio frequency secured by this process is passed on to the a-f system for amplification and final reproduction. The d-c voltage which results from detection of the signal is used for automatic volume control. This voltage, which develops across resistor R-8, is applied as automatic control-grid bias to the r-f, first-detector, and i-f tubes through suitable resistance-capacitance filter circuits. The second diode of the RCA-6H6 is used to supply residual bias for these controlled tubes under conditions of little or no signal. This diode, under such conditions, draws current, which flows through R-9 and R-8, thereby maintaining the desired minimum operating bias on such tubes. On application of signal energy above a certain level, however, the auxiliary bias diode ceases to draw current and the a.v.c. diode takes over the biasing function.

## SERVICE DATA

The various diagrams of this booklet contain such information as will be needed for servicing the receiver. The ratings of all resistors, capacitors, coils, etc., are indicated adjacent to the symbols signifying these parts on the diagrams. The coils, reactors, and transformer windings are rated in terms of their d-c resistances only. Ratings of less than one ohm are generally omitted. Identification titles such as R-3, L-2, C-1, etc., are provided for reference between the illustrations and replacement parts.

### Alignment Procedure

The extensive frequency range of this receiver necessitates a more or less involved method of alignment. However, if the following directions are carefully applied, the normal performance of the instrument will be obtained.

Correct performance of the receiver can only be obtained when the trimmer adjustments have been made by a skilled service man with the use of adequate and reliable test equipment. Such apparatus as

may be required for this particular instrument is illustrated and described on a separate page of this booklet.

Two methods of alignment are applicable. One utilizes a Cathode-Ray Oscillograph as a means of output indication and the other follows former procedure where a glow type indicator or meter is used. The oscillographic method is much to be preferred, since greater accuracy is possible from the type of indication afforded. There are no approximations necessary as with the meter or aural method, but each adjustment can be made with excellent precision. Both methods are hereinafter outlined so that alignment operations may be made according to the equipment available.

It is wise to determine the necessity for alignment as well as the direction of misalignment before making adjustments. The RCA Tuning Wand is an instrument designed particularly for such a purpose.

The Tuning Wand consists of a bakelite rod having a small brass cylinder at one end and a core of finely divided iron at the other. It may be inserted into a tuned coil while a signal of the normal resonant frequency is being supplied to such coil to obtain an indication of the tuning. Holes are provided at the top of the r-f shield cans for entrance of the Wand. The presence of either end of the Wand will cause a change in tuning which will be indicated at the receiver output as an increase or decrease in signal level. If there is a decrease of output when either end is inserted, the tuning is correct and will require no adjustment. However, should there be an increase of output due to the iron core and decrease with the brass cylinder, an increase in inductance or capacitance is indicated as necessary to bring the circuit into line. The trimmer involved should therefore be increased accordingly. If the brass cylinder end causes an increase in output while the iron end causes a decrease, reduction of inductance will be necessary to place the circuit in alignment. This is equivalent to decreasing the trimmer concerned. The following tabulation gives the various changes and the adjustments required:

WAND	SIGNAL	TRIMMER
{ Brass	Decrease	None
{ Iron	Decrease	None
{ Brass	Increase	Decrease
{ Iron	Decrease	Decrease
{ Brass	Decrease	Increase
{ Iron	Increase	Increase

### Radiotron Socket Voltages

The voltage values indicated from the Radiotron socket contacts to chassis on Figure 5 will serve to assist in the location of causes for faulty operation. Each value as specified should hold within  $\pm 20\%$  when the receiver is normally operative at its rated supply voltage. Variations in excess of this limit will usually be indicative of trouble in the basic circuits. The voltages given are actual operating values and do not allow for inaccuracies which may be caused by the loading effect of a voltmeter's internal resistance. This resistance should be duly considered for all readings. The amount of circuit resistance shunting the meter during measurement will determine the accuracy to be obtained, the error increasing as the meter resistance becomes comparable to or less than the circuit resistance. For the majority of readings, a meter having an internal resistance of 1,000-ohms-per-volt will be satisfactory when the range used for each reading is chosen as high as possible consistent with good readability.

RCA MFG. CO., INC.

MODEL D9-19  
 Socket, Trimmers  
 Voltage, Pickup  
 Loudspeaker

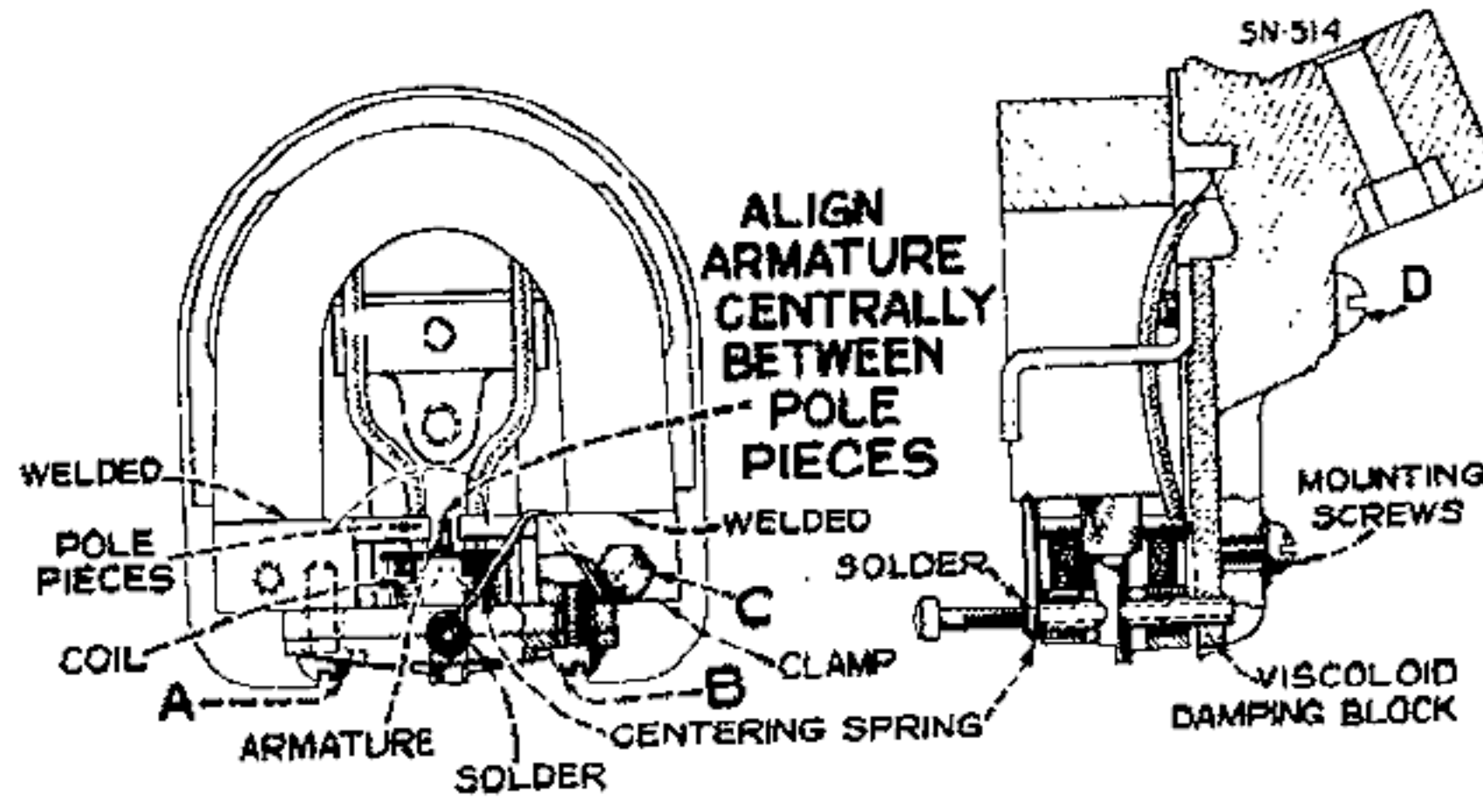

Figure 10—Details of Pickup

RADIOTRON COMPLEMENT

- (1) RCA-6K7.....Radio-Frequency Amplifier
- (2) RCA-6L7.....First Detector
- (3) RCA-6J7.....Heterodyne Oscillator
- (4) RCA-6K7.....Intermediate Amplifier
- (5) RCA-6H6.....Second Detector and A.V.C.
- (6) RCA-6F5.....Audio Amplifier
- (7) RCA-6F6.....Power Output Amplifier
- (8) RCA-5Z3.....Full Wave Rectifier
- (9) RCA-6E5.....Tuning Indicator

For Fig. 4 Alignment Apparatus Connections, see Model 9T & 9K2, Fig. 4

Figure 5—Radiotron Socket Voltages

-No signal being received  
 Measured at 115 volts, 60 cycle supply—

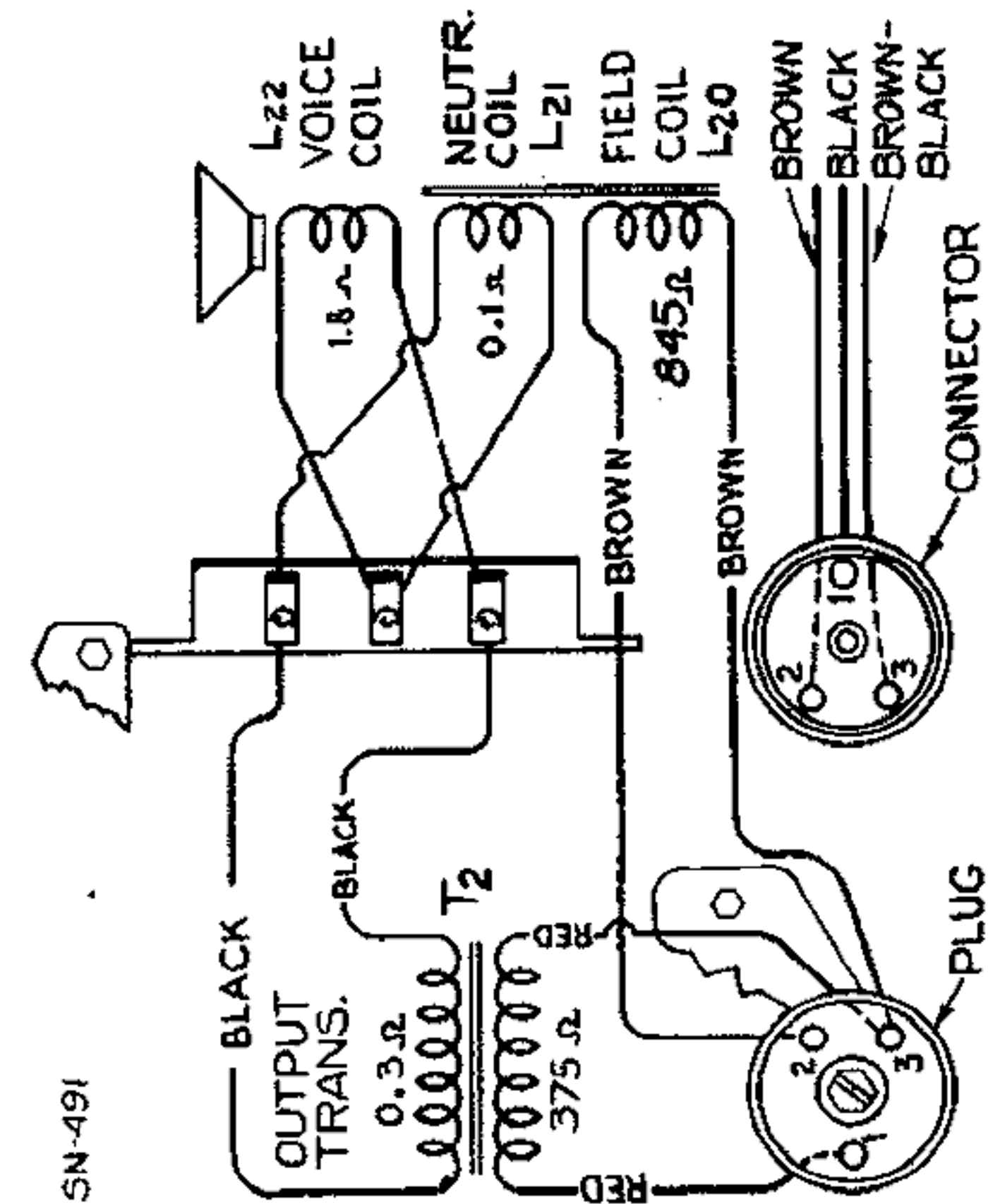
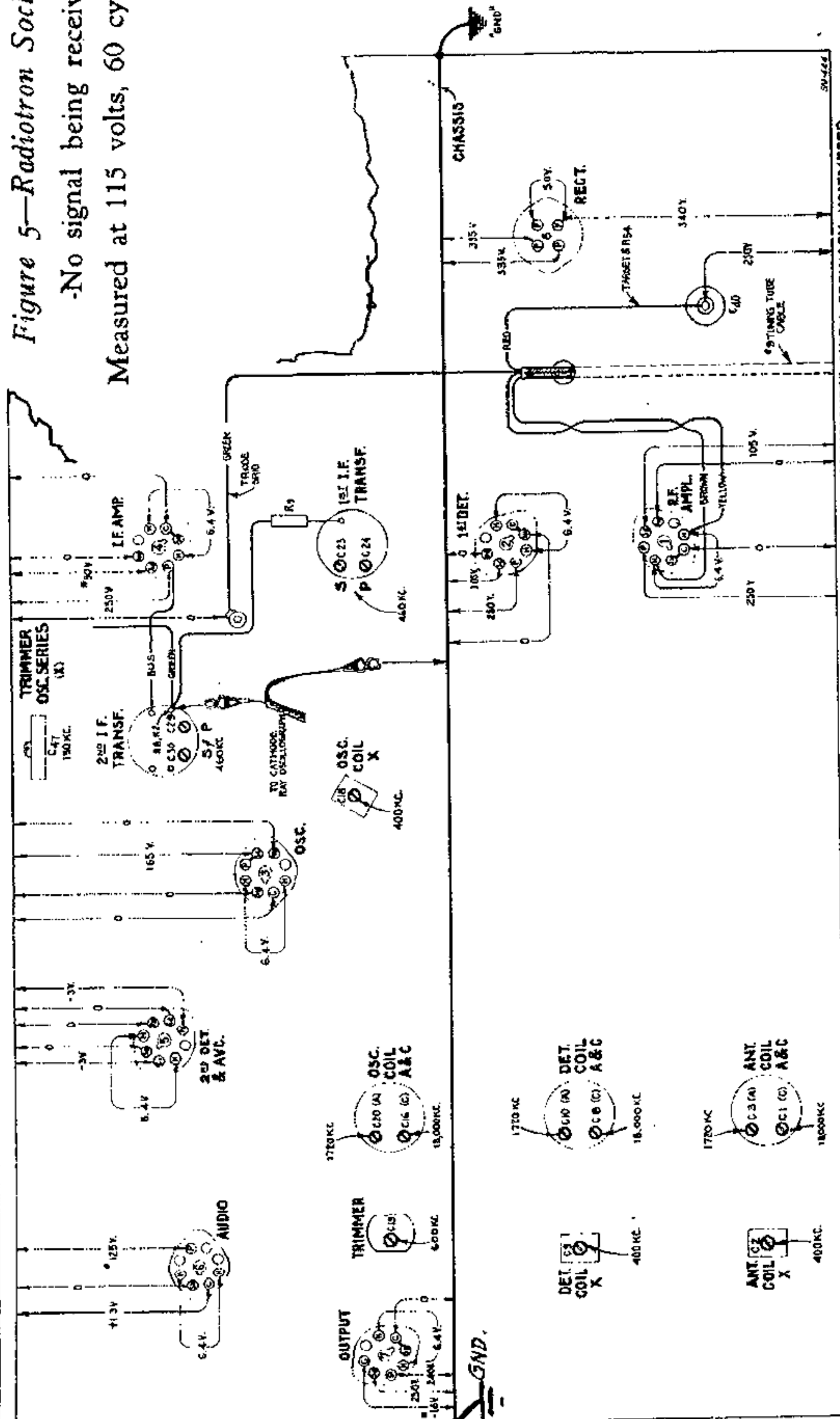

Figure 6—Loudspeaker Wiring

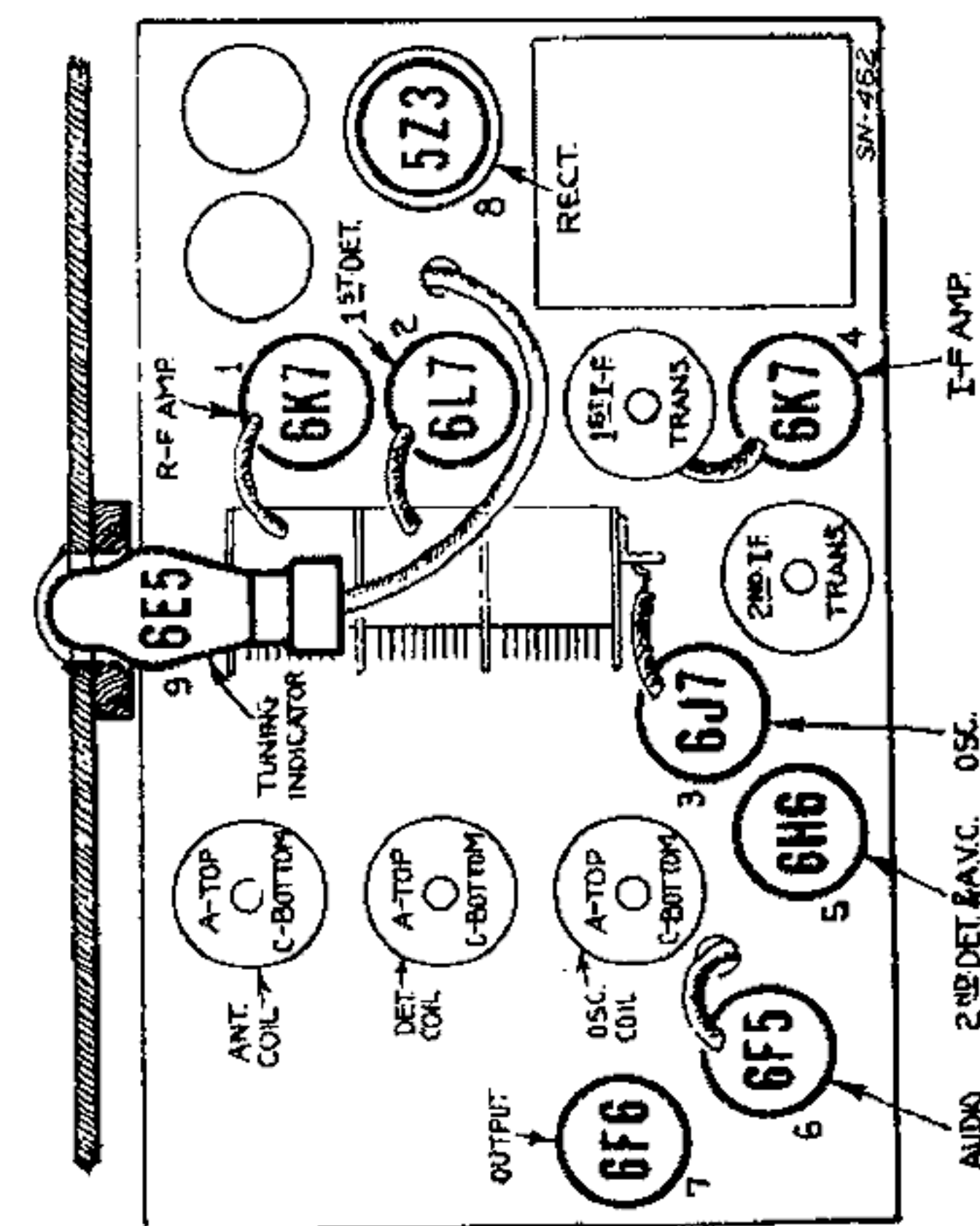
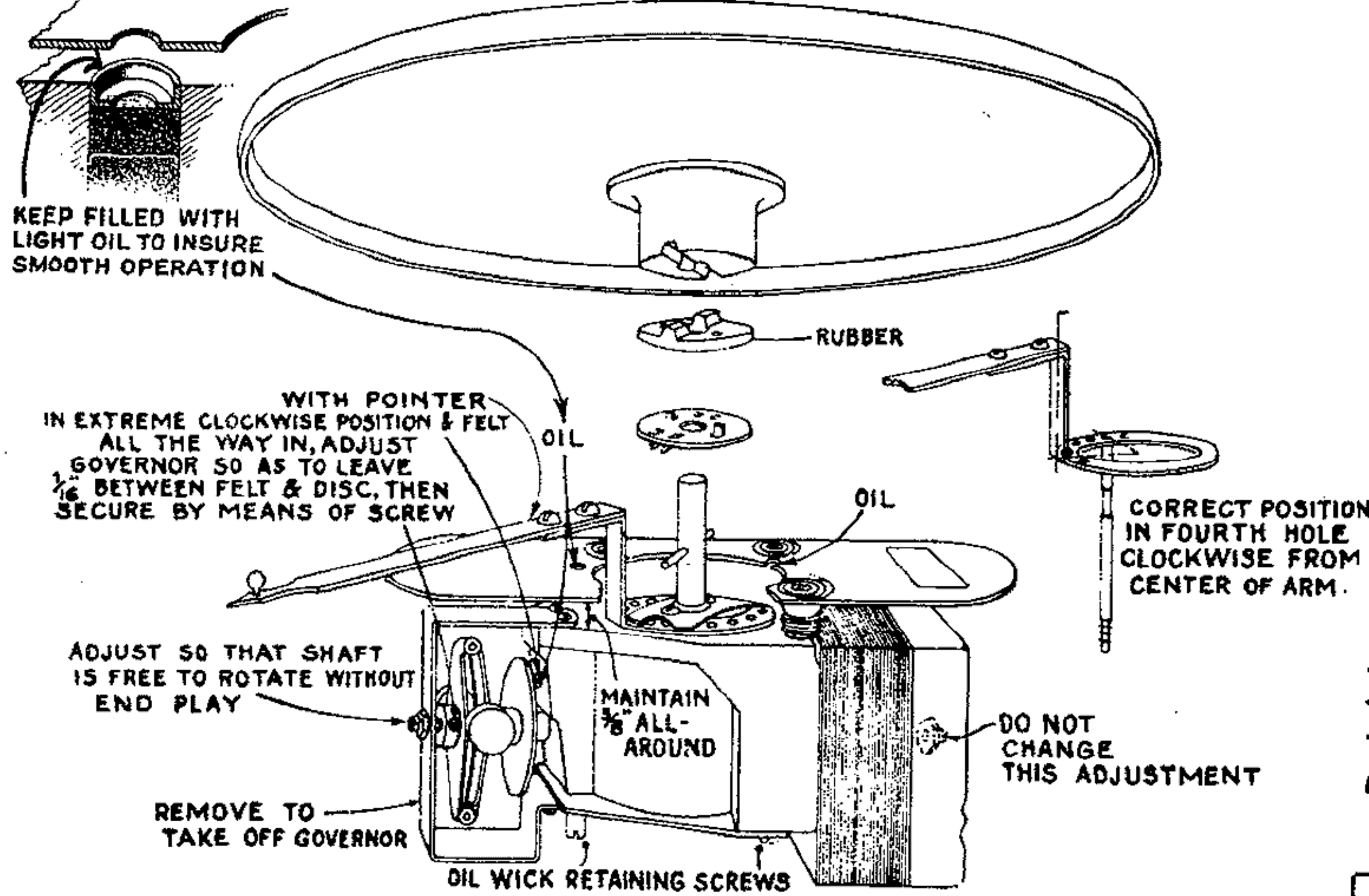

Figure 7—Radiotron and Coil Locations

MODEL D9-19  
Assembly Wiring

RCA MFG. CO., INC.

Motor Details



**Dial Adjustment**

Figure 10 illustrates the relations of the various parts of the dial mechanism when it is in its A — Broadcast position and the range switch is likewise turned to its Band A setting. In re-assembling the dial after repairs, see that the gears are meshed in accordance with the diagram, at the same time noting that the lever which is attached to the range-switch shaft is in the position as shown.

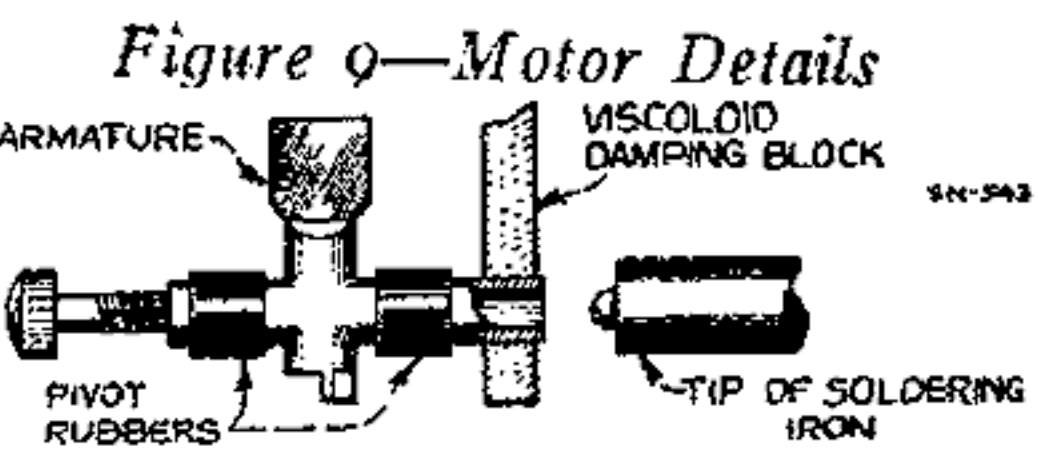

Figure 9—Motor Details  
Figure 11—Special Soldering-Iron Tip

**MOTOR BOARD**

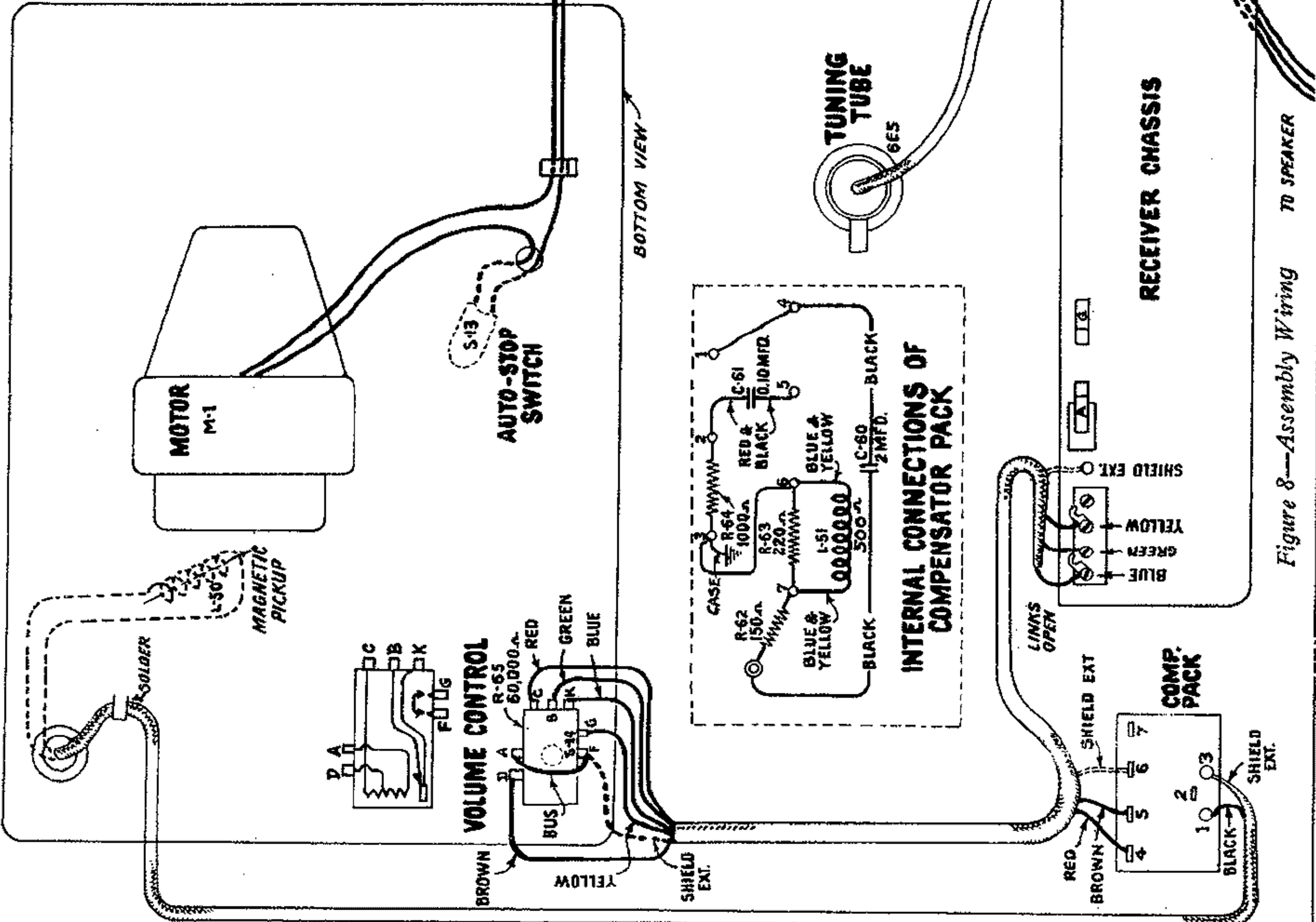

Figure 8—Assembly Wiring

## REPLACEMENT PARTS

Insist on genuine factory tested parts, which are readily identified and may be purchased from authorized dealers

Stock No.	DESCRIPTION	List Price	Stock No.	DESCRIPTION	List Price	Stock No.	DESCRIPTION	List Price	Stock No.	DESCRIPTION	List Price
<b>RECEIVER ASSEMBLIES</b>											
11698	Board—Three-terminal phonograph terminal board	\$0.22	11172	Resistor—470,000 Ohm—Carbon type— $\frac{1}{4}$ Watt—(R14)—Package of 5	1.00	4596	Escutcheon—Speed regulator escutcheon plate	.36	8060	Bracket—Output transformer mounting bracket	.14
4427	Bracket—Volume control or high-frequency tone control mounting bracket	.18	11151	Resistor—22 Megohms—Carbon type— $\frac{1}{4}$ Watt—(R9, R60, R67)—Package of 5	1.00	4597	Screw—Motor mounting screw assembly—comprising four screws, four lockwashers, four spacers, and four nuts	.22	11257	Clamp—Cone center suspension clamping nut and screw assembly—Package of 5	2.00
5237	Bushing—Variable tuning condenser mounting bushing assembly—Package of 3	.43	5249	Shield—Antenna, detector, or oscillator coil shield	.20	11696	Turntable—Complete	2.48	11254	Coil—Field coil (L20)	2.00
11350	Cap—Contact cap—Package of 5	.20	5250	Shield—I.F. transformer shield	.22	11695	Volume Control—Phonograph volume control (R65, S14)	1.60	11233	Coil—Hum neutralizing coil (L21)	.30
11223	Capacitor—Adjustable capacitor (C19)	.46	11273	Shield—Rectifier Radiotron shield	.25				11258	Cone—Reproducer cone (L22)—Package of 5	3.85
11256	Capacitor—Adjustable capacitor (C-47)	.48	11222	Socket—Dial lamp socket	.18				5118	Connector—Three-contact male connector for reproducer	.25
11292	Capacitor—22 MMfd. (C7)	.24	4794	Socket—Four-contact rectifier Radiotron socket	.15				5119	Connector—Three-contact female connector plug for reproducer cable	.25
11321	Capacitor—33 MMfd. (C33)	.26	11313	Socket—Five-contact Radiotron socket	.18	3994	Cover—Eccentric automatic switch cover and screw	.26	9619	Reproducer—Complete	6.05
11289	Capacitor—50 MMfd. (C11)	.26	11198	Socket—Seven-contact Radiotron socket	.15	10174	Springs—Automatic brake springs—comprising one each of four springs—Package of 2	.50	11253	Transformer—Output transformer (T2)	1.56
11291	Capacitor—115 MMfd. (C21)	.24	11236	Switch—Band switch (S1, S2, S3, S4, S5, S6, S7, S8, S9, S10, S11)	2.44	6896	Switch—Eccentric automatic brake and switch assembly—less switch cover	2.50	11230	Washer—"Binder's board" "C" washers—Used to hold field coil assembly	.18
5116	Capacitor—175 MMfd. (C35)	.18	11133	Switch—Power switch (S12)	.62	3322	Switch—Eccentric automatic switch only—less cover (S13)	.75			
11290	Capacitor—400 MMfd. (C46)	.25	5238	Terminal—Antenna terminal clip assembly	.14				<b>MISCELLANEOUS ASSEMBLIES</b>		
11269	Capacitor—800 MMfd. (C46)	.30	11238	Tone Control—High-frequency tone control (R20)	.96				11191	Bracket—Tuning tube mounting bracket—less clamp	.12
4409	Capacitor—120 MMfd. (C38)	.35	11216	Transformer—First intermediate frequency transformer (L16, L17, C24, C25)	2.15				11192	Clamp—Tuning tube mounting clamp—less bracket	.12
11287	Capacitor—4500 MMfd. (C15)	.30	11239	Transformer—Second intermediate frequency transformer (L18, L19, C29, C30, C31, R7, R8)	2.72				11694	Compensator—Phonograph input compensator pack—comprising one 150-ohm, one 220-ohm, and one 1000-ohm resistor, one 0.1 Mfd. and one 2 Mfd. capacitor, and one 0.25 H reactor—(R62, R63, R64, C60, C61, L51)	3.80
4858	Capacitor—.005 Mfd. (C34)	.20	11242	Transformer—Power transformer—105-125 Volts—25-60 Cycles	6.52	11705	Arm—Pickup arm complete—less escutcheon and pickup unit	4.50			
4838	Capacitor—.005 Mfd. (C44)	.20	11243	Transformer—Power transformer—100-130, 140-160, 195-250 Volts—40-60 Cycles—(T1)	4.64	11707	Armature—Pickup armature	.28	11337	Escutcheon—Station selector escutcheon	.70
4624	Capacitor—.01 Mfd. (C32)	.54	11237	Volume control (R11)	1.20	6346	Back—Pickup housing back	.45	11276	Escutcheon—Radiotron tuning tube escutcheon	.40
4856	Capacitor—.01 Mfd. (C37, C49, C50*)	.25				11708	Cover—Pickup back cover	.18	11246	Foot—Chassis mounting foot and bracket assembly—Package of 2	.76
5196	Capacitor—.035 Mfd. (C43)	.18	<b>DRIVE ASSEMBLIES</b>			11709	Cover—Pickup front cover	.15	6614	Glass—Station selector dial glass	.30
4886	Capacitor—.05 Mfd. (C50*)	.20	4362	Arm—Band indicator operating arm	.28	3321	Damper—Pickup damper—Package of 5	.65	11346	Knob—Station selector knob—Package of 5	.75
4836	Capacitor—.05 Mfd. (C4, C13, C26)	.30	10194	Ball—Steel ball—Package of 20	.25	11708	Escutcheon—Pickup arm escutcheon	.46	11347	Knob—Phonograph volume control, radio volume control, tone control, power switch or range switch knob—Package of 5	.75
4885	Capacitor—.01 Mfd. (C6, C12, C27)	.28	4422	Clutch—Tuning condenser drive clutch assembly—comprising drive shaft, balls, ring, spring and washers—assembled	1.00	3337	Pickup Unit—Complete (L50)	4.80	4678	Ring—Retaining ring for station selector dial glass—Package of 5	.34
5170	Capacitor—.025 Mfd. (C23, C28, C36)	.25	11252	Dial—Dial scale	.60	11549	Rod—Eccentric automatic brake trip rod—Package of 5	.40	11210	Screw—Chassis mounting screw assembly—Package of 4	.28
11248	Capacitor—4 Mfd. (C41)	1.06	11252	Drive—Variable tuning condenser drive assembly	1.88	11547	Screw—Pickup mounting screw assembly—comprising one screw, one lockwasher and one nut—Package of 10	.40	11348	Screw—No. 8-32-7/16" set-screw for knob—Stock No. 11346—Package of 10	.32
11240	Capacitor—10 Mfd. (C39)	1.08	4520	Indicator—Station selector indicator pointer	.18				3391	Spring—Motor board mounting spring assembly—comprising one bolt, one "C" washer, two cup washers, one bottom spring, one lockwasher, and one cap nut	.50
5212	Capacitor—18 Mfd. (C40)	1.16	11226	Indicator—Band indicator pointer assembly—comprising indicator pointer, arm, link and stud	.20				11349	Spring—Retaining spring for knob—Stock No. 11347—Package of 5	.15
11272	Clamp—Antenna cable clamp—Located near antenna terminal	.10	3993	Screw—No. 6-32-5/32" square set-screw for band indicator operating arm—Package of 10	.25						
4748	Clamp—Capacitor mounting clamp assembly—for Stock No. 11248	.15	4669	Screw—No. 8-32-5/32" set-screw for variable condenser drive assembly—Package of 10	.25						
5215	Coil—Antenna coil (A and C Bands)—(L1, L2, L5, L6, C1, C3)	2.32	4377	Spring—Band indicator operating arm spring—Package of 5	.25						
11325	Coil—Antenna coil (X Band)—(L3, L4, C2)	1.56	4378	Stud—Band indicator operating arm stud and nut assembly—Package of 5	.25						
5216	Coil—Detector coil (A and C Bands)—(L7, L8, L11, L12, C8, C10)	2.34									
11326	Coil—Detector coil (X Band)—(L9, L10, C9)	1.60	<b>MOTOR ASSEMBLIES</b>								
5217	Coil—Oscillator coil (A and C Bands)—(L13, L15, C16, C20)	2.20	11703	Governor—Governor complete for phonograph motor—Stock No. 11701 or No. 11702	3.05						
11327	Coil—Oscillator coil (X Band)—(L14, L23, C18)	1.44	11701	Motor—Phonograph turntable motor—110 Volts—50 to 60 Cycles—(M1)	21.20						
11214	Condenser—Three-gang variable tuning condenser (C5, C14, C22)	4.20	11702	Motor—Phonograph turntable motor—110 Volts—25 Cycles	33.35						
11697	Cover—Phonograph terminal board cover	.12									
4340	Lamp—Dial lamp—Package of 5	.60	<b>MOTOR BOARD ASSEMBLIES</b>								
8041	Plate—R.F. or I.F. coil shield locking plate—Package of 2	.12	4594	Box—Used needle box (cup)	.30						
11244	Resistor—Voltage divider resistor, comprising one 7500-ohm and one 9200-ohm sections (R18, R19)	1.08	7084	Cover—Turntable cover	.40						
11245	Resistor—Voltage divider resistor, comprising one 148-ohm, one 32-ohm, and one 110-ohm section (R15, R16, R17)	.62	11704	Damper—Turntable rubber damper and damper plate							
5112	Resistor—1000 Ohm—Carbon type— $\frac{1}{4}$ Watt—(R2)—Package of 5	1.00									
5114	Resistor—15,000 Ohm—Carbon type—1 Watt—(R5)	.22									
11300	Resistor—33,000 Ohm—Carbon type— $\frac{1}{10}$ Watt—(R4)—Package of 5	.75									
11322	Resistor—39,000 Ohm—Carbon type— $\frac{1}{4}$ Watt—(R10)—Package of 5	1.00									
5029	Resistor—56,000 Ohm—Carbon type— $\frac{1}{4}$ Watt—(R13)—Package of 5	1.00									
3118	Resistor—100,000 Ohm—Carbon type— $\frac{1}{4}$ Watt—(R1, R3, R6)—Package of 5	1.00									
11323	Resistor—270,000 Ohm—Carbon type— $\frac{1}{4}$ Watt—(R12)—Package of 5	1.00									

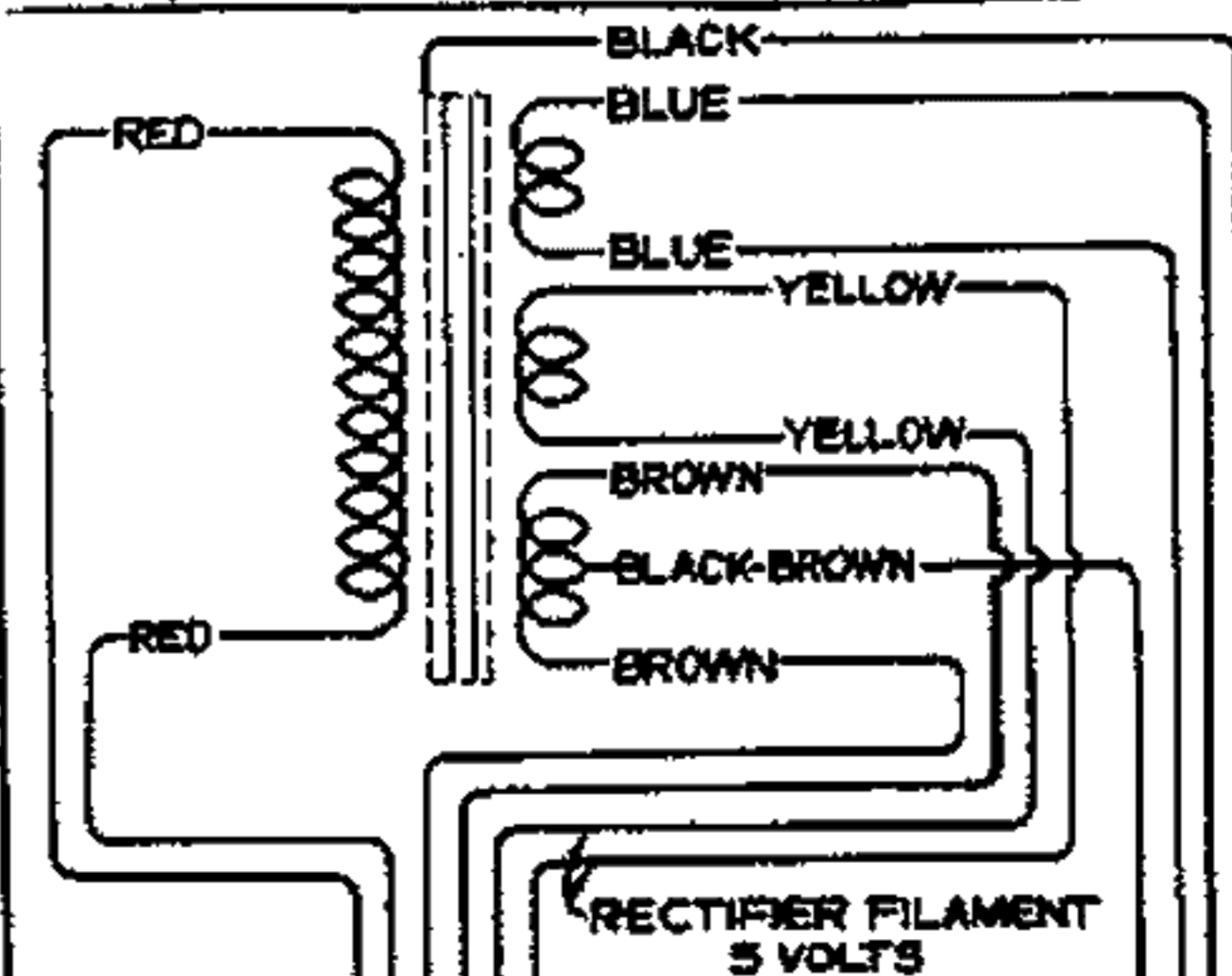

Figure 7—Standard Power Transformer Connections  
Pri. Res. = 5.42 ohms total  
Sec. Res. = 470 ohms total

RCA MFG. CO., INC.

MODEL D9-19  
Parts List

MODEL D9-19  
Chassis Wiring

RCA MFG. CO., INC.

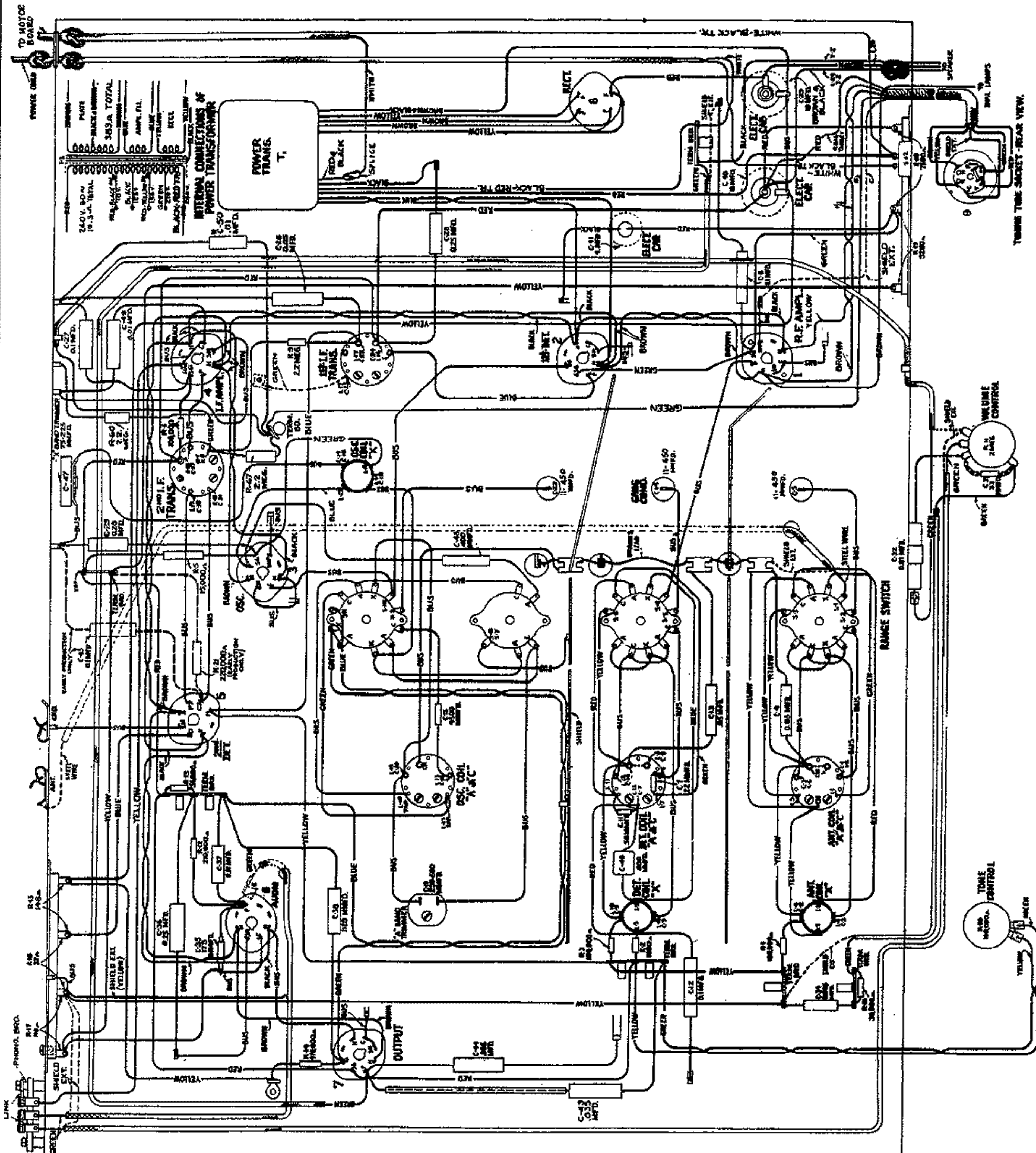

**LOUDSPEAKER**  
Type .....12-inch Electrodynamc  
Voice Coil Impedance.....2 1/4 Ohms at 400 Cycles

**POWER OUTPUT RATINGS**  
Undistorted ..... 2 Watts  
Maximum ..... 4 1/2 Watts

**PHONOGRAPH**  
Type .....Manual  
Turntable Speed.....(Adjustable) 78 R.P.M.

Type of Pickup Improved High-Impedance Magnetic  
Pickup Impedance.....2,800 Ohms at 1,000 Cycles