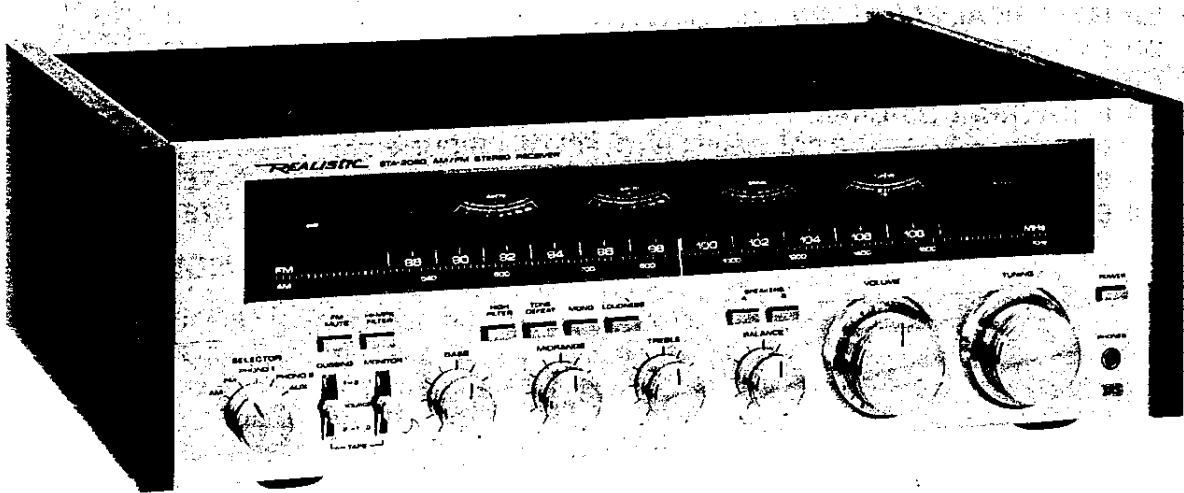


REALISTIC[®]

Service Manual

31-3000

STA-2080
AM/FM STEREO RECEIVER
Catalog Number: 31-3000



CUSTOM MANUFACTURED FOR RADIO SHACK  A DIVISION OF TANDY CORPORATION

CONTENTS

	Page
1) ELECTRICAL PERFORMANCE SPECIFICATIONS	3 - 5
2) DISASSEMBLY INSTRUCTIONS	6 - 7
3) BLOCK DIAGRAM	8
4) DIAL STRINGING DIAGRAM	9
5) LEVEL DIAGRAM	9
6) OPERATION CHECK FOR CIRCUITS	10 - 18
7) ALIGNMENT INSTRUCTIONS	19 - 23
8) BRIEF DESCRIPTION OF PROTECTOR CIRCUITS	24 - 25
9) TROUBLESHOOTING	26 - 30
10) IC & TRANSISTOR LEAD IDENTIFICATION	31
11) IF & TUNER P.C.B. (TOP & BOTTOM VIEWS)	32 - 33
12) PRE AMP P.C.B. (TOP & BOTTOM VIEWS)	34
13) TONE CONTROL P.C.B. (TOP & BOTTOM VIEWS)	35
14) MAIN AMP P.C.B. (LEFT) (TOP & BOTTOM VIEWS)	36
15) MAIN AMP P.C.B. (RIGHT) (TOP & BOTTOM VIEWS)	37
16) PROTECTOR P.C.B. (TOP & BOTTOM VIEWS)	38
17) TAPE P.C.B. (TOP & BOTTOM VIEWS)	38
18) FUSE P.C.B. (TOP & BOTTOM VIEWS)	38
19) POWER SUPPLY P.C.B. (TOP & BOTTOM VIEWS)	39
20) SWITCH P.C.B. (TOP & BOTTOM VIEWS)	40
21) POWER TRANSISTOR P.C.B. (LEFT & RIGHT) (TOP & BOTTOM VIEWS)	40
22) LED P.C.B. (TOP & BOTTOM VIEWS)	40
23) ELECTRICAL PARTS LIST	41 - 48
24) EXPLODED VIEW PARTS LIST	49 - 52
25) MISCELLANEOUS PARTS LIST	52
26) IC INTERNAL DIAGRAM	53 - 57
27) VOLTAGE CHART FOR PRE AMP & PROTECTOR CIRCUITS	58
28) SCHEMATIC DIAGRAM	SEPARATE SHEET
29) EXPLODED VIEW	SEPARATE SHEET

1) ELECTRICAL PERFORMANCE SPECIFICATIONS

AM SECTION

- Notes:** 1. Output readings are taken across a non-reactive 47K load termination.
 2. Output is measured at TAPE OUT terminals.
 3. The Generator output shall terminate in an IRE loop and pointing towards rear of the receiver.
 4. Standard modulation: 400 Hz, 30% modulation.

	UNIT	NOMINAL	LIMIT
Frequency Coverage	(kHz)	515-1650	520-1620
IF	(kHz)	455	--
Antenna Sensitivity for S/N 20 dB at 600 kHz, 1000 kHz and 1400 kHz	(μ V/m)	200	400
S/N Ratio at 5 mV/m Input	(dB)	45	40
Selectivity at S/N 6 dB Sens. (1000 kHz \pm 10 kHz)	(dB)	35	25
AGC Distortion at 1000 kHz, 100 mV/m, 80% modulation	(%)	1.8	5.0
IF Rejection at 600 kHz	(dB)	56	48
Image Rejection Ratio at 1400 kHz	(dB)	60	52
Bandwidth at 6 dB down, 1000 kHz	(kHz)	6.0	4.5-8.0
Distortion at 30% mod. 5 mV/m Input	(%)	1.0	3.0
Tape Out Level at 30%, 5 mV/m Input	(mV)	200	200 \pm 2.5 dB
Audio Fidelity at 5 mV/m Input (1 kHz = 0 dB) -6 dB Point	(Hz)	40-2.8 K	50-2.5 K
Whistle Modulation of 2nd and 3rd Harmonic at 1 mV and 5 mV Input	(%)	3.0	10
Calibration at 600 kHz	(kHz)	--	\pm 25
at 1400 kHz	(kHz)	--	\pm 50
Spurious Response at 1000 kHz referred to 20 dB S/N Input	(dB)	60	40
AGC Figure of Merit at 1000 kHz	(dB)	48	40

The oscillator shall not drift more than 10 kHz starting at 25°C and through range up to 50°C at 1000 kHz.

The set shall operation in satisfactory manner through a temperature range from 0°C through plus 45°C.

Overload: With a radiated signal of 1 V/m, the signal shall be tunable without distortion or breakup.

FM SECTION

- Notes:** 1. Output readings are taken across a non-reactive 47K load termination.
 2. Output is measured at TAPE OUT terminals.
 3. The signal voltage in this specification is the voltage appearing across the tuner input terminals (IHF).
 4. Standard Modulation: 1000 Hz 75 kHz deviation.

	UNIT	NOMINAL	LIMIT
Frequency Coverage (UL, C.S.A.)	(MHz)	86.5-109	88-108
*(European, Australian)	(MHz)	87.5-109	87.5 \pm 0.2-108
IF	(MHz)	10.7	--
IHF Sensitivity at 90, 98 and 106 MHz	(μ V)	1.7	2.8
	(dBf)	9.7	14.2
S/N 50 dB Quieting Sensitivity at 90, 98 and 106 MHz (UL, C.S.A.)	(μ V)	3.0	4.5
	(dBf)	14.7	18.3
(European, Australian)	(μ V)	3.5	5.0

	UNIT	NOMINAL	LIMIT
-3 dB Limiting Sensitivity at 98 MHz	(μ V)	1.5	2.0
IF Rejection Ratio at 90 MHz	(dB)	95	80
Image Rejection Ratio at 106 MHz	(dB)	80	70
Spurious Response	(dB)	90	75
Capture Ratio	(dB)	1.5	2.5
ACA at +400 kHz 50 μ V Input	(dB)	75	60
FM Mono Distortion, 75 kHz deviation	(%)	0.2	0.5
Calibration Accuracy at 90, 98 and 106 MHz	(kHz)	---	± 300
AFC Holding Range at 98 MHz	(kHz)	± 250	± 330
AM Suppression (FM 75 kHz dev. AM 30% mod.)	(dB)	55	48
Maximum signal handling Capacity	(mV)	200	100
Tape Out Level 1 mV, 75 kHz dev.	(mV)	640	640 ± 2 dB
Muting Sensitivity	(μ V)	2.5	2-6
S/N Ratio at 1 mV Input (98 MHz)	(dB)	70	65
Frequency Response at 10 kHz			
(UL, C.S.A.)	(dB)	-13.66	-13.66 ± 2 dB
(European, Australian)	(dB)	-10.37	-10.37 ± 2 dB

Temperature range for satisfactory operation is 0°C to 45°C.

All sets must meet the requirements of the Radiation Regulations (FCC, FTZ).

*European models must not be able to tune below 87.5 MHz.

FM MPX SECTION

- Notes: 1. Output readings are taken across a non-reactive 47K load termination.
2. Output is measured at TAPE OUT terminals.
3. The signal voltage in this specification is the voltage appearing across the tuner input terminals.
4. Standard modulation: Main carrier (L + R) ----- 33.75 kHz dev. (45%)
Sub carrier (L - R) ----- 33.75 kHz dev. (45%)
Pilot (19 kHz) --- 6 kHz dev. (8%)
Modulation Frequency --- 1000 Hz

	UNIT	NOMINAL	LIMIT
Stereo Indicator Sensitivity	(μ V)	2.5	2 - 6
Stereo Separation at 1 mV Input at 100 Hz	(dB)	35	30
at 1 kHz	(dB)	48	33
at 10 kHz	(dB)	33	28
Stereo Distortion at 1 mV Input	(%)	0.3	0.7
Sub-Carrier Rejection Ratio	(dB)	60	54
SCA Rejection Ratio	(dB)	60	54
Stereo Tape Out Level	(mV)	580	580 ± 2 dB
FM MPX Filter (Separation at 10 kHz)	(dB)	10	10 ± 2.5

AUDIO SECTION

	UNIT	NOMINAL	LIMIT
Input Impedance PHONO Mag.	(k Ω)	50	---
AUX	(k Ω)	100	---
TAPE IN 1	(k Ω)	100	---
TAPE IN 2	(k Ω)	100	---
Output Power THD 0.03%, Both Channels Driven at 1 kHz, 8 ohms	(W)	87	83
Power Bandwidth THD 0.03%, Both Channels Driven at 8 ohms from 20 Hz to 20 kHz	(W)	85	80

	UNIT	NOMINAL	LIMIT
Audio Distortion at Rated Power (80W) from 20 Hz to 20 kHz 8 ohms, Both Channels Driven (UL, C.S.A.)	(%)	0.03	0.08
Audio Distortion at Rated Power (60W) from 20 Hz to 20 kHz, 8 ohms, One Channel Driven (European, Australian)	(%)	0.06	0.08
Sensitivity for Rated Power at 8 ohms (75 W)			
PHONO 1 & 2 Mag.	(mV)	2.2	3.5
AUX	(mV)	160	160 ± 2 dB
TAPE IN 1 & 2	(mV)	160	160 ± 2 dB
Frequency Response at AUX 5W ± 2dB	(Hz)	15 — 25K	20 — 20 K
BASS Action at 100 Hz	(dB)	± 10	± 10 ± 2 dB
MIDRANGE Action at 1.5 kHz	(dB)	± 6	± 6 ± 2 dB
TREBLE Action at 10 kHz	(dB)	± 10	± 10 ± 2 dB
S/N Ratio (Input Shorted)			
PHONO 1 & 2 Mag.	(dB)	70	60
AUX, TAPE IN 1 & 2	(dB)	75	65
Hum and Noise at Minimum Volume	(mV)	0.8	1.5
Hum and Noise at Maximum Volume (AUX) (4.7 k Ω terminated)	(mV)	15	35
Cross Talk at 1 kHz, AUX position (Input 4.7 k Ω terminated)	(dB)	60	50
Loudness Control			
Bass Compensation at 100 Hz, —30 dB Volume	(dB)	+6	+6 ± 2 dB
Treble Compensation at 10 kHz, —30 dB Volume	(dB)	+4.5	+4.5 ± 2 dB
Level Difference of each channel	(dB)	0	1.5
High Filter Effect at 10 kHz	(dB)	—6	—6 ± 2 dB
PHONO Mag. Equalizer Response at 20 Hz	(dB)	RIAA	RIAA ± 1.5 dB
at 20 kHz	(dB)	RIAA	RIAA ± 1.5 dB
PHONO Overload at 1 kHz, 0.5% THD	(mV)	200	150
Tape Out Level (47 k Ω terminated)			
PHONO 1 & 2 Mag. (2.2 mV Input)	(mV)	140	140 ± 2 dB
AUX (160 mV Input)	(mV)	140	140 ± 2 dB
TAPE IN 1 & 2 (160 mV Input)	(mV)	140	140 ± 2 dB
TAPE Out Level for DIN Jack (3.3 k Ω terminated)			
AM — 400 Hz, 30% modulation 5 mV Input	(mV)	3.3	3.3 ± 2.5 dB
FM — 1000 Hz, 22.5 kHz dev. 1 mV Input	(mV)	3.3	3.3 ± 2.5 dB
PHONO Mag. — 3.3 mV Input	(mV)	3.3	3.3 ± 2.5 dB
AUX — 250 mV Input	(mV)	3.3	3.3 ± 2.5 dB
S/N Ratio			
PHONO 1 Mag.	(dB)	90	84
PHONO 2 Mag. (10 mV Input, "A" weighted) (Rated Power, Input Shorted)	(dB)	90	84
IM Distortion at Rated Power (80W)	(%)	0.04	---
Music Power at 0.08% THD, 1 kHz, 8 ohms (European and Australian models only)	(W)	130	110

- Notes:**
- The supply voltage is 120 volts AC, 60 Hz (UL, C.S.A.), (220/240 volts AC, 50 Hz for European and 240 volts AC, 50 Hz for Australian models) from a regulated power supply.
 - The power source must be insulated from other equipment, connected antenna or output.
 - The room temperature is 25 degrees C.
 - Nominal Specs represent the design specs; all units should be able to approximate these — some will exceed and some may drop slightly below these specs.
Limit Specs represent the absolute worst condition which still might be considered acceptable: in no case should a unit perform to less than within any Limit Spec.

2) DISASSEMBLY INSTRUCTIONS

1. Remove the Top Cover (Metal plate) as follows:

Remove three screws from the upper Back Panel as shown in Figure A. Then slide the Top Cover out toward rear of the unit.

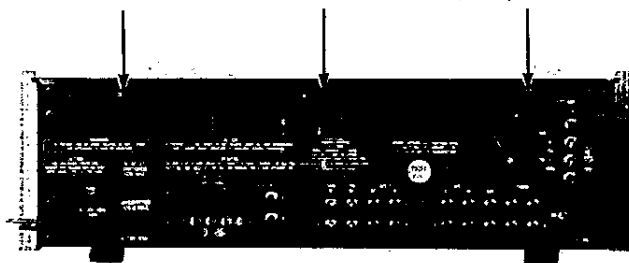


Figure A

2. Remove the Bottom Cover (Metal plate) as follows:

Turn the Receiver upside down and remove nine screws from the bottom board as shown in Figure B.

Lift the Bottom Cover off.

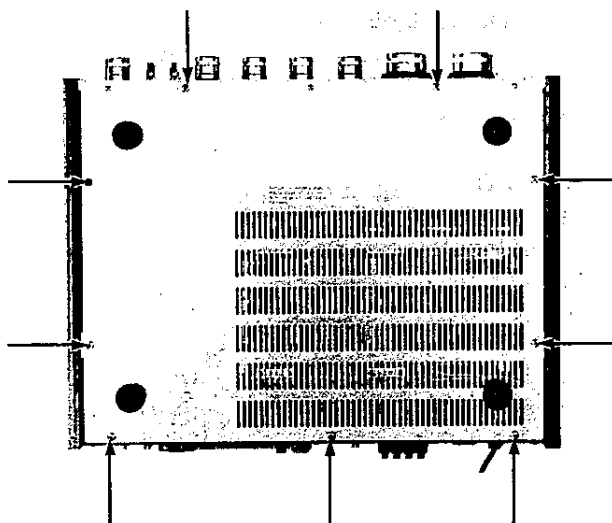


Figure B

3. Remove the wooden sides from the Cabinet as follows:

Remove four screws from each side of the Cabinet as shown in Figure C. Be careful not to loosen the screw inserts when the screws are removed.



Figure C

4. To remove the Front Panel (Aluminium Panel):

- a) Remove the Top Cover, Bottom Cover and wooden sides from the Cabinet as described in 1, 2 and 3.
- b) Remove knobs which can be pulled off easily.
- c) Remove four screws from the Front Panel — two screws from the left side and two screws from the right side as shown in Figure D1 & D2.
- d) Remove three screws from bottom of the Front Panel (Figure D3).

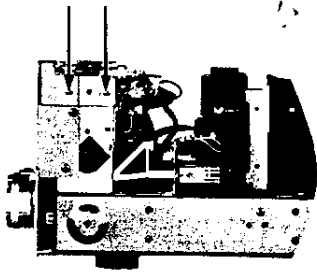


Figure D1

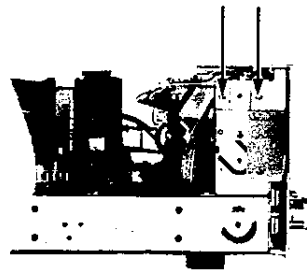


Figure D2

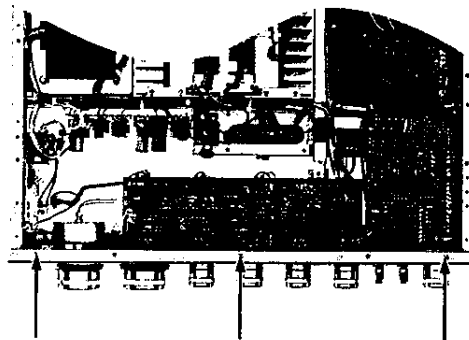


Figure D3

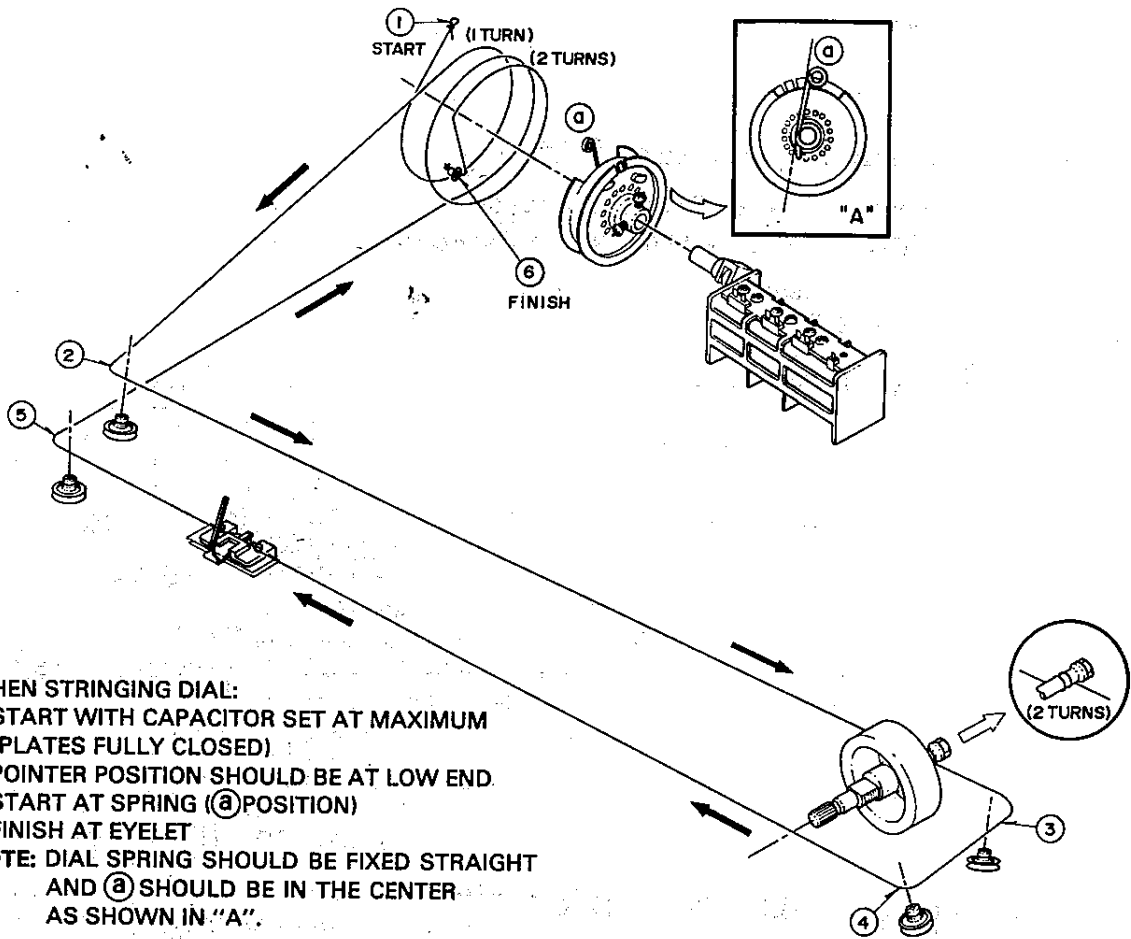
5. To remove Rear Panel from Chassis:

Remove six screws from the Rear Panel (Figure E).

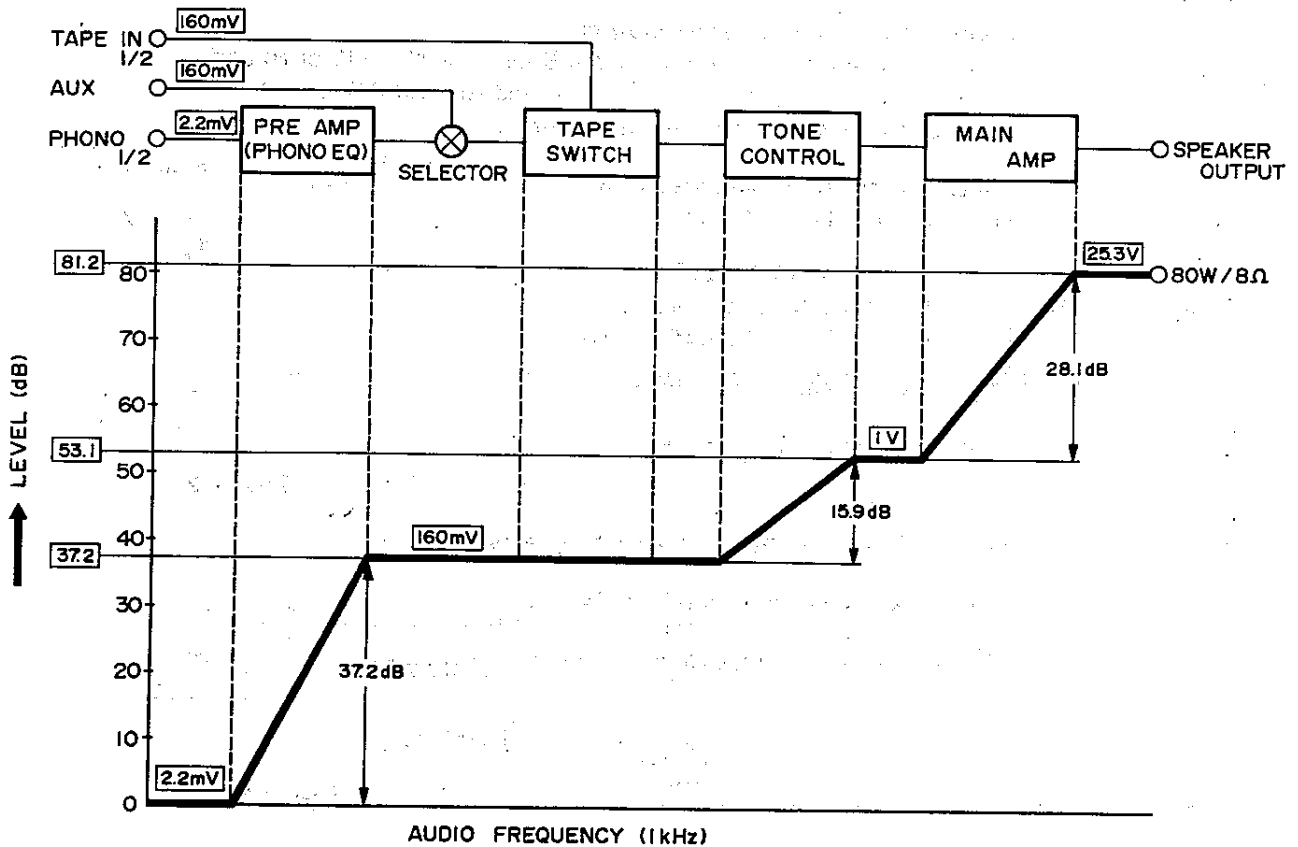


Figure E

4) DIAL STRINGING DIAGRAM

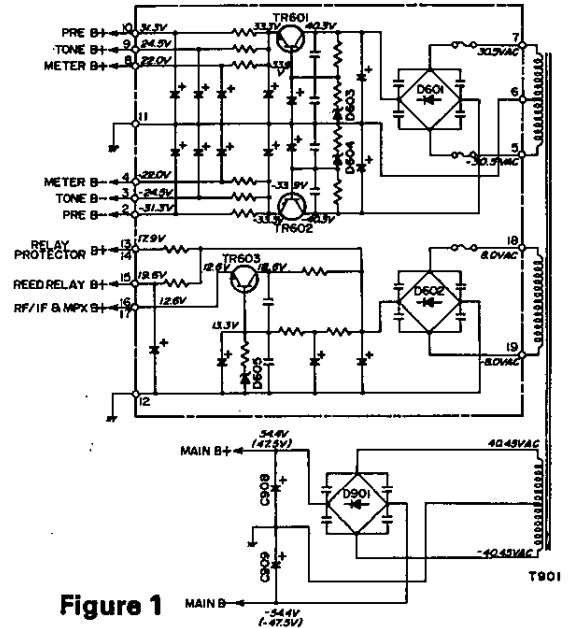
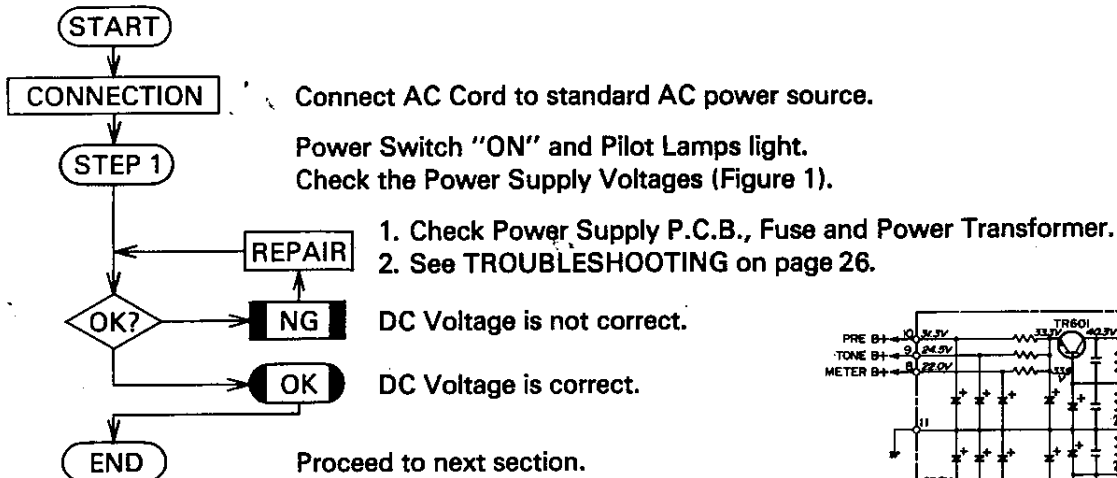


5) LEVEL DIAGRAM



6) OPERATION CHECK FOR CIRCUITS

1) POWER SUPPLY OPERATION CHECK



2) AUDIO SECTION OPERATION CHECK

(1) MAIN AMP. OPERATION CHECK

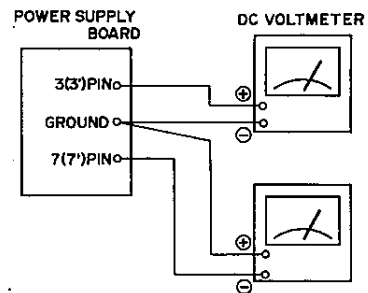
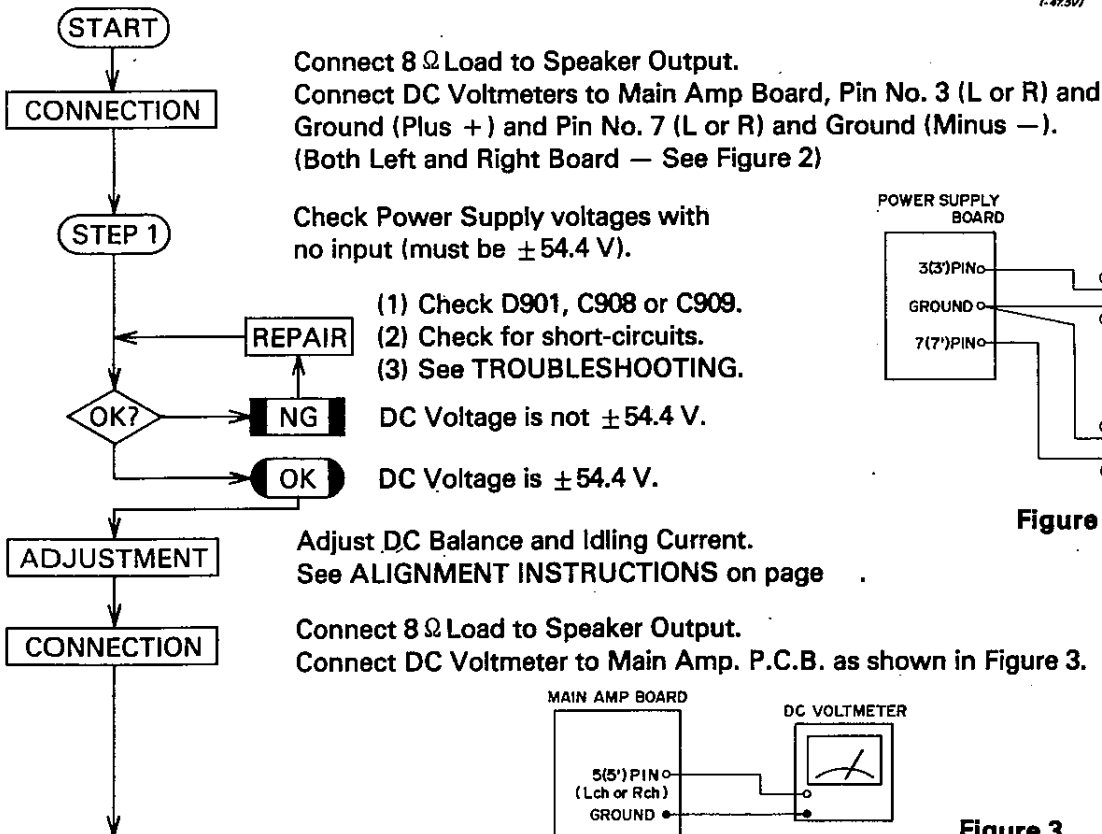


Figure 2

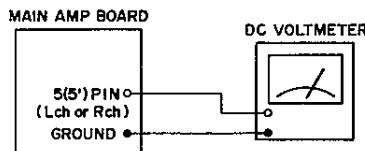
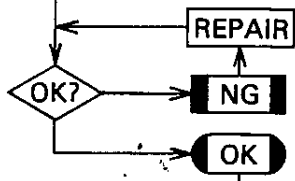


Figure 3

STEP 2

Check for Balance of DC Voltage at L and R channel output terminals (within ± 50 mV).



CONNECTION

Connect 8Ω Load to Speaker Output.
Connect DC Voltmeter to Main Amp. P.C.B. as shown in Figure 4.

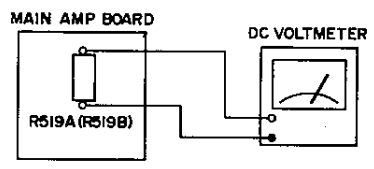
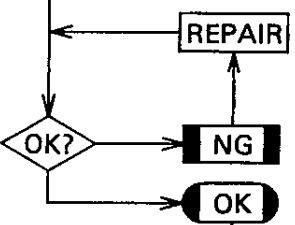


Figure 4

STEP 3

Check the Idling current of Main Amp:
Check the DC Voltage across Emitter Resistor R509A (L ch) and R509B (R ch); should be $10 \text{ mV} \pm 2 \text{ mV}$.
(ADJUST: VR501A (L ch) and VR501B (R ch))



- (1) Readjust VR501A and VR501B.
- (2) Check the Bias circuit of D503A (L ch) and/or D503B (R ch)
- (3) Check TR505A (L ch) and TR505B (R ch).
- (4) Check TR504A, 506A (L ch) and TR504B, 506B (R ch).
- (5) Check for short-circuits on Main P.C.B.

CONNECTION

Connect 8Ω Load to Speaker Output.
Connect Audio Osc. to Main Amp. Input, Pin No. 1 (Left) and/or 1' (Right). See Figure 5.

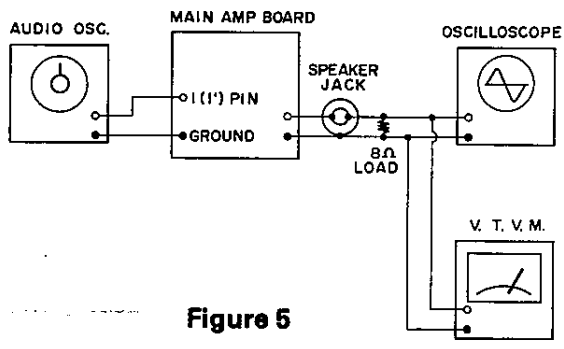
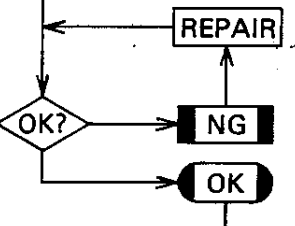


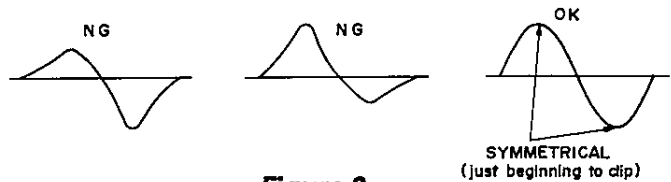
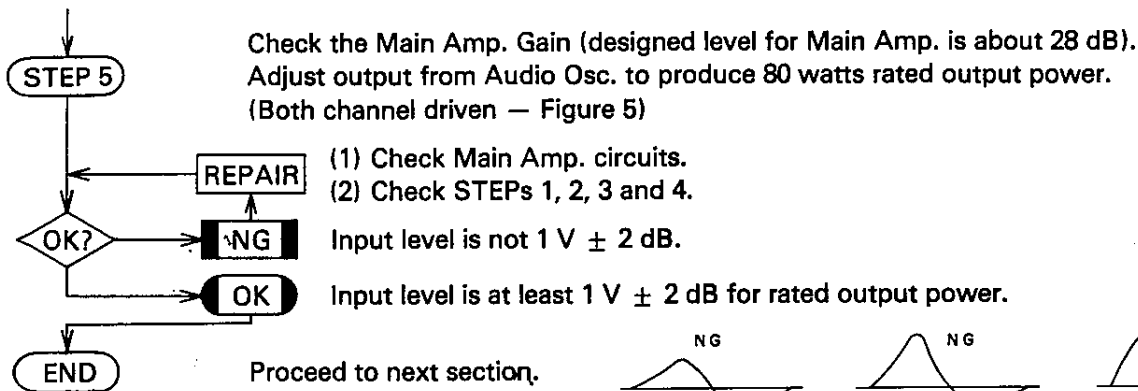
Figure 5

STEP 4

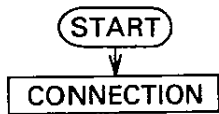
Check for symmetrical clipping of Output Signal wave shape.
Adjust output from Audio Osc. to produce clipping in the output waveform (should be about $1 \text{ V} - 1.1 \text{ V}$).



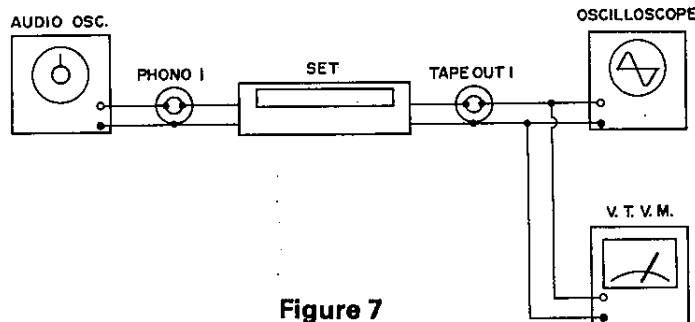
- (1) Check TR505A, 507A, 508A, 509A, 510A (L ch) and TR505B, 507B, 508B, 509B, 510B (R ch).
- (2) Check STEP 2 and STEP 3.
- (3) Check Main Amp. circuits.



(2) PRE AMP. OPERATION CHECK

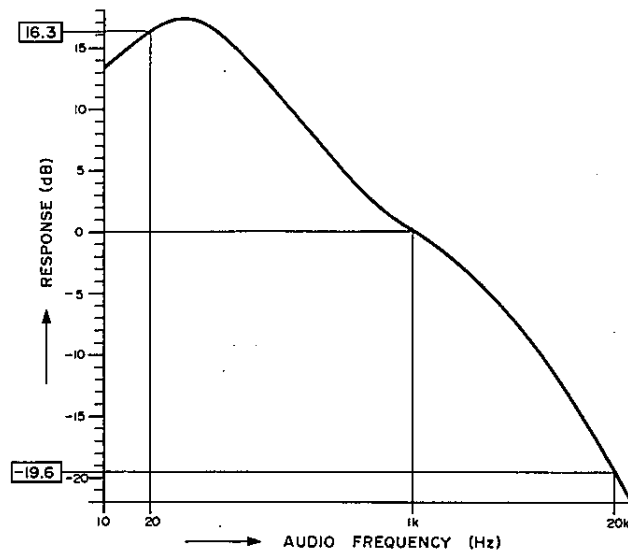


Set SELECTOR Switch to PHONO 1.
Connect Audio Osc. to PHONO 1 Input.
Connect Oscilloscope and V.T.V.M. to TAPE OUT 1 Jack. (See Figure 7)

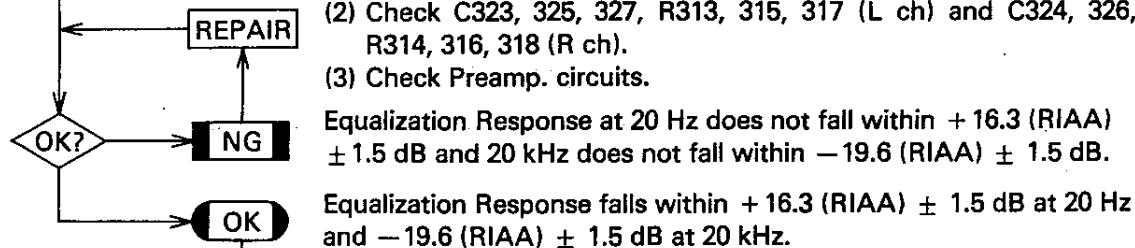


STEP 1

Check the PHONO Equalization Response. (See Figure 8, RIAA Curve.)

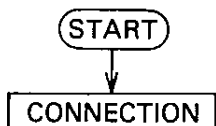


- (1) Check TR301, 303, 305, 307 (L ch) and TR302, 304, 306, 308 (R ch).
- (2) Check C323, 325, 327, R313, 315, 317 (L ch) and C324, 326, 328, R314, 316, 318 (R ch).
- (3) Check Preamp. circuits.



END Proceed to next section.

(3) TONE CONTROL OPERATION CHECK



Set SELECTOR Switch to AUX position.
 Connect Audio Osc. to AUX input jack.
 Connect Oscilloscope and V.T.V.M. to Speaker Jack on Set.
 Speaker Impedance = 8 ohms (OUTPUT: about 5 watts)
 TAPE DUBBING: SOURCE, TAPE MONITOR: SOURCE, MODE
 Switch: Stereo, LOUDNESS: Off. (See Figure 9)

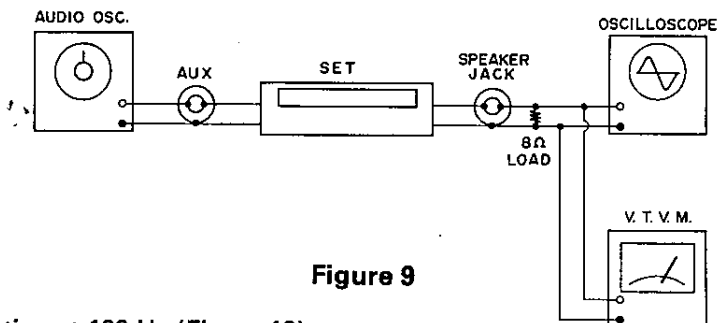


Figure 9

STEP 1

Check BASS Action at 100 Hz (Figure 10)

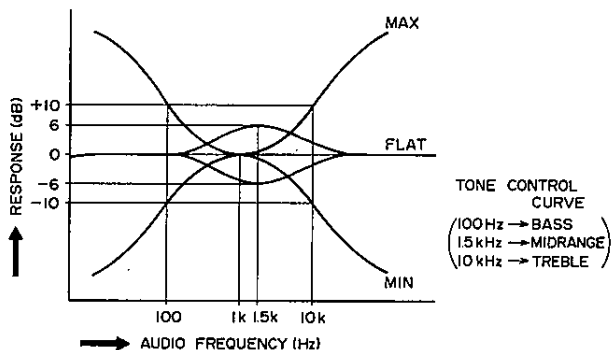
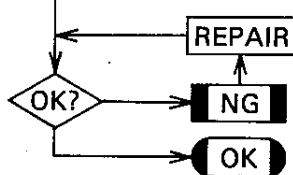


Figure 10



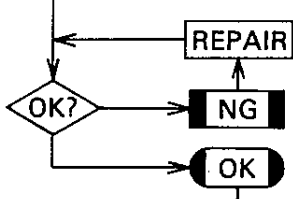
Check Bass Control circuit on TONE CONTROL P.C.B. and see TROUBLESHOOTING.

Frequency Response does not fall within $\pm 10 \pm 2$ dB.

Frequency Response falls within $\pm 10 \pm 2$ dB.

STEP 2

Check TREBLE Action at 10 kHz. (Figure 10)



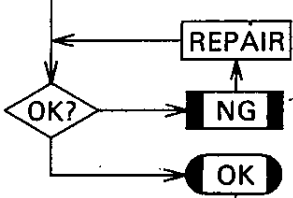
Check Treble Control circuits on TONE CONTROL P.C.B. and see TROUBLESHOOTING.

Frequency Response does not fall within $\pm 10 \pm 2$ dB.

Frequency Response falls within $\pm 10 \pm 2$ dB.

STEP 3

Check MIDRANGE at 1.5 kHz. (Figure 10)



Check Midrange control circuit on TONE CONTROL P.C.B.

Frequency Response does not fall within $\pm 6 \pm 2$ dB.

Frequency Response falls within $\pm 6 \pm 2$ dB.

STEP 4

Check LOUDNESS compensation at -30 dB Volume position from rated power. (Figure 11)

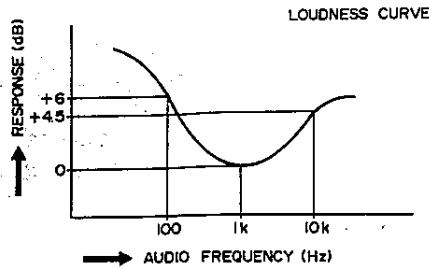
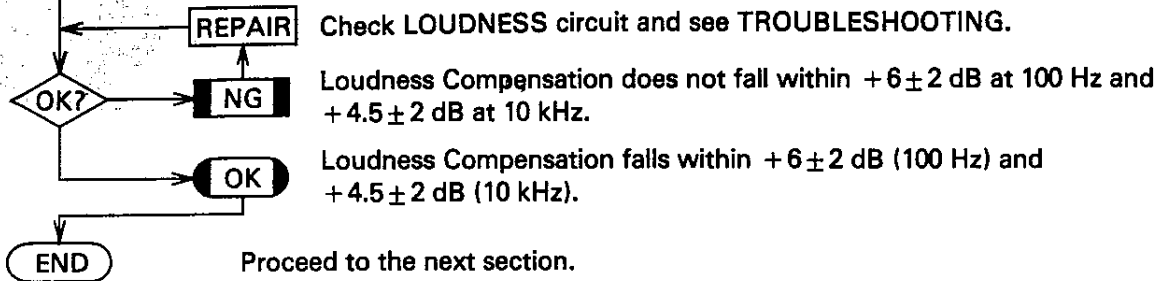


Figure 11



(4) PROTECTOR CIRCUITS OPERATION CHECK

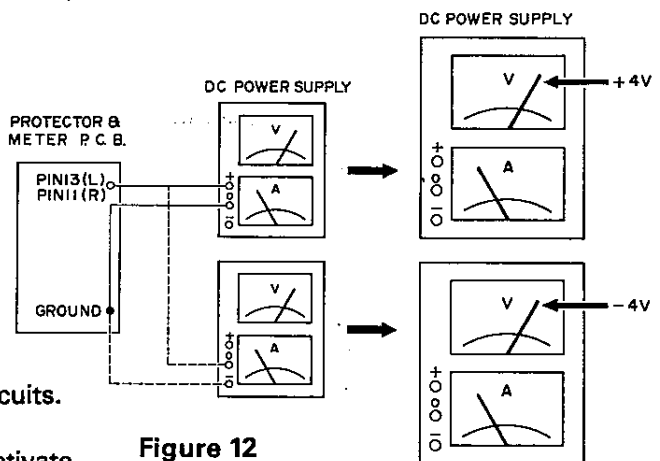
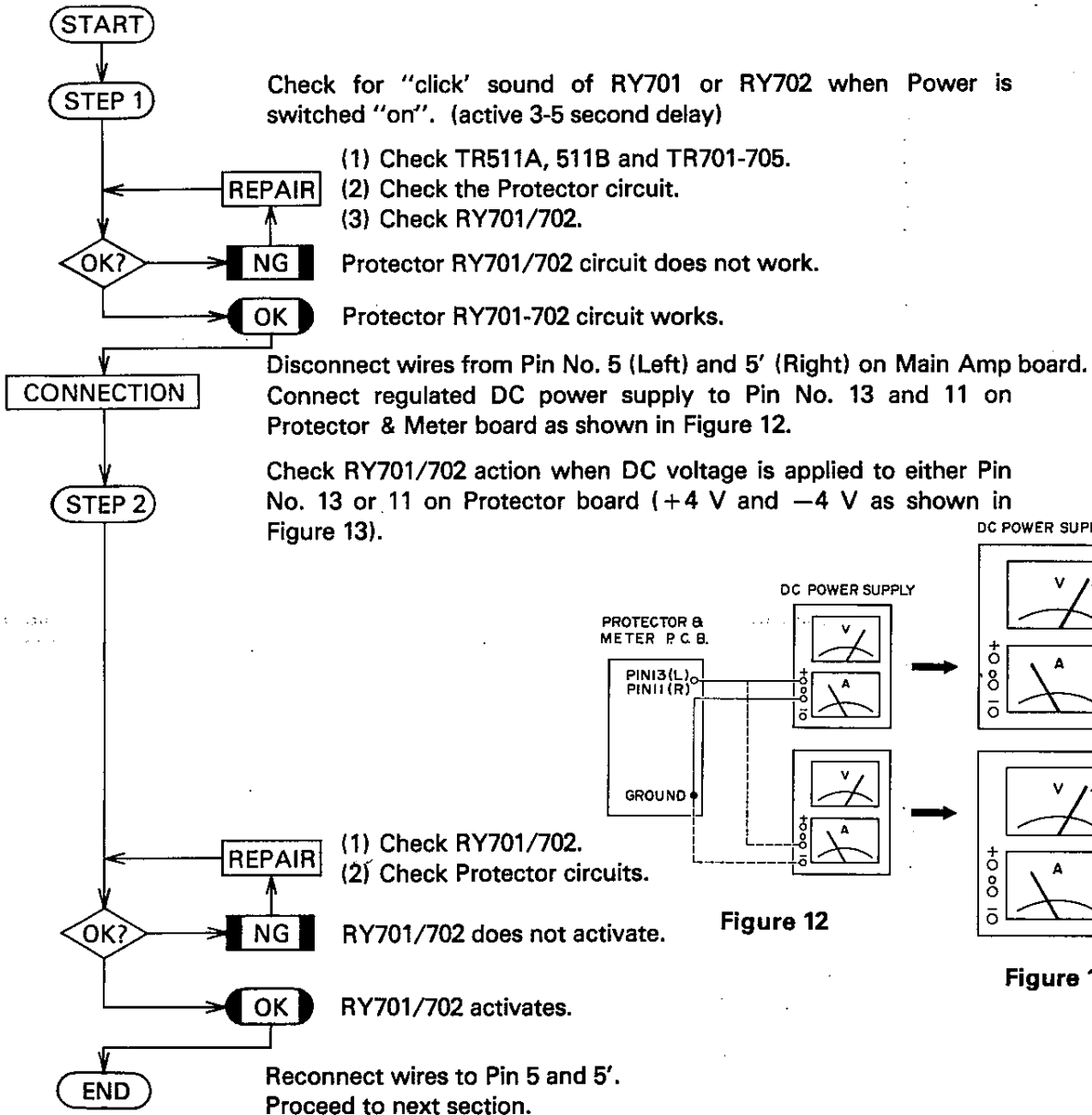
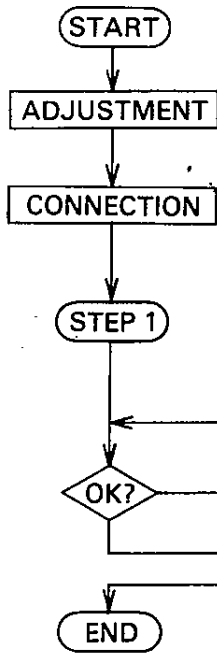


Figure 12

Figure 13

(5) WATTS METER OPERATION CHECK



Adjust VR701 (L ch) and VR702 (R ch).
(See ALIGNMENT INSTRUCTIONS on page 19.)

Connect Audio Osc. (1 kHz) to AUX Input Jack.
Connect Oscilloscope and V.T.V.M. to Speaker terminals.
(Output level: 100 watts, no load as shown in Figure 14)

Check Watts Meter pointers (L ch and R ch) per following procedure:
Check Watts Meter pointers as 1 watt and 100 watts (L ch and R ch) when output levels are set to 2.8 V and 28.3 V on V.T.V.M. (no load).

Readjust VR701 and 702.
See TROUBLESHOOTING.

Watt Meter pointers do not indicate correctly.

Watt Meter pointers indicate correctly.

Proceed to next section.

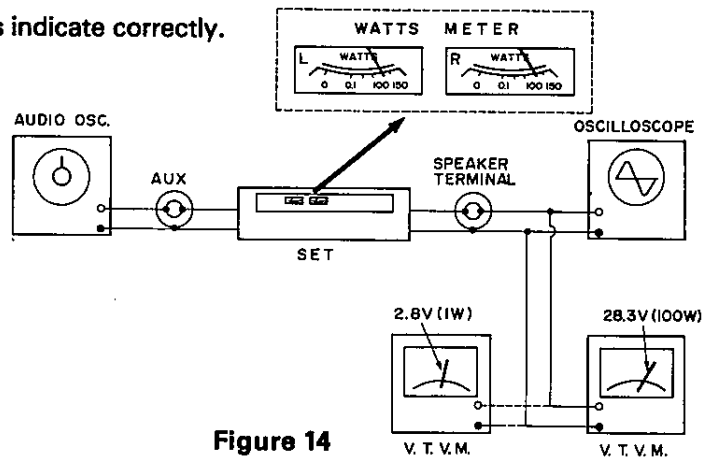
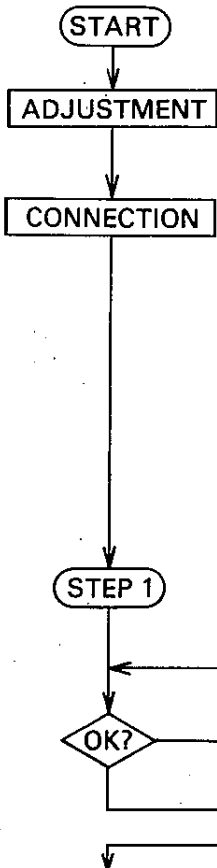


Figure 14

3) RF AND IF OPERATION CHECK

(1) AM OPERATION CHECK



Adjust for AM IF/RF Alignment (See AM ALIGNMENT Section on page 20).

Set SELECTOR Switch to AM position. Connect standard loop antenna to AM SG and radiate signal into AM Ferrite Antenna L902.
Connect Oscilloscope, Distortion Meter and V.T.V.M. to TAPE OUT 1 jack on Set.
AM SG: 400 Hz, 30% modulation.

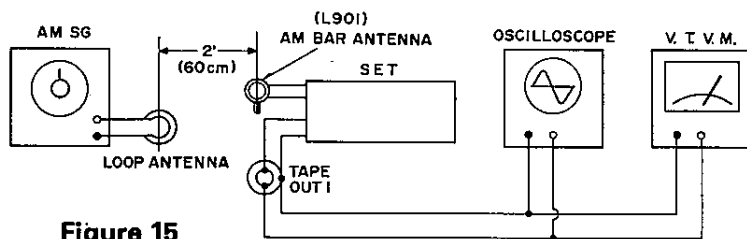


Figure 15

Check AM coverage: that the lowest dial pointer setting is under 520 kHz and highest position is over 1620 kHz.

Readjust AM coverage (See page 20 for AM Alignment).

Coverage is less than 520 kHz — 1620 kHz.

Coverage is at least 520 kHz — 1620 kHz.

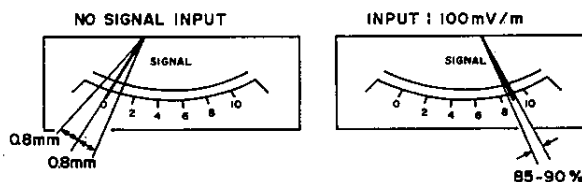
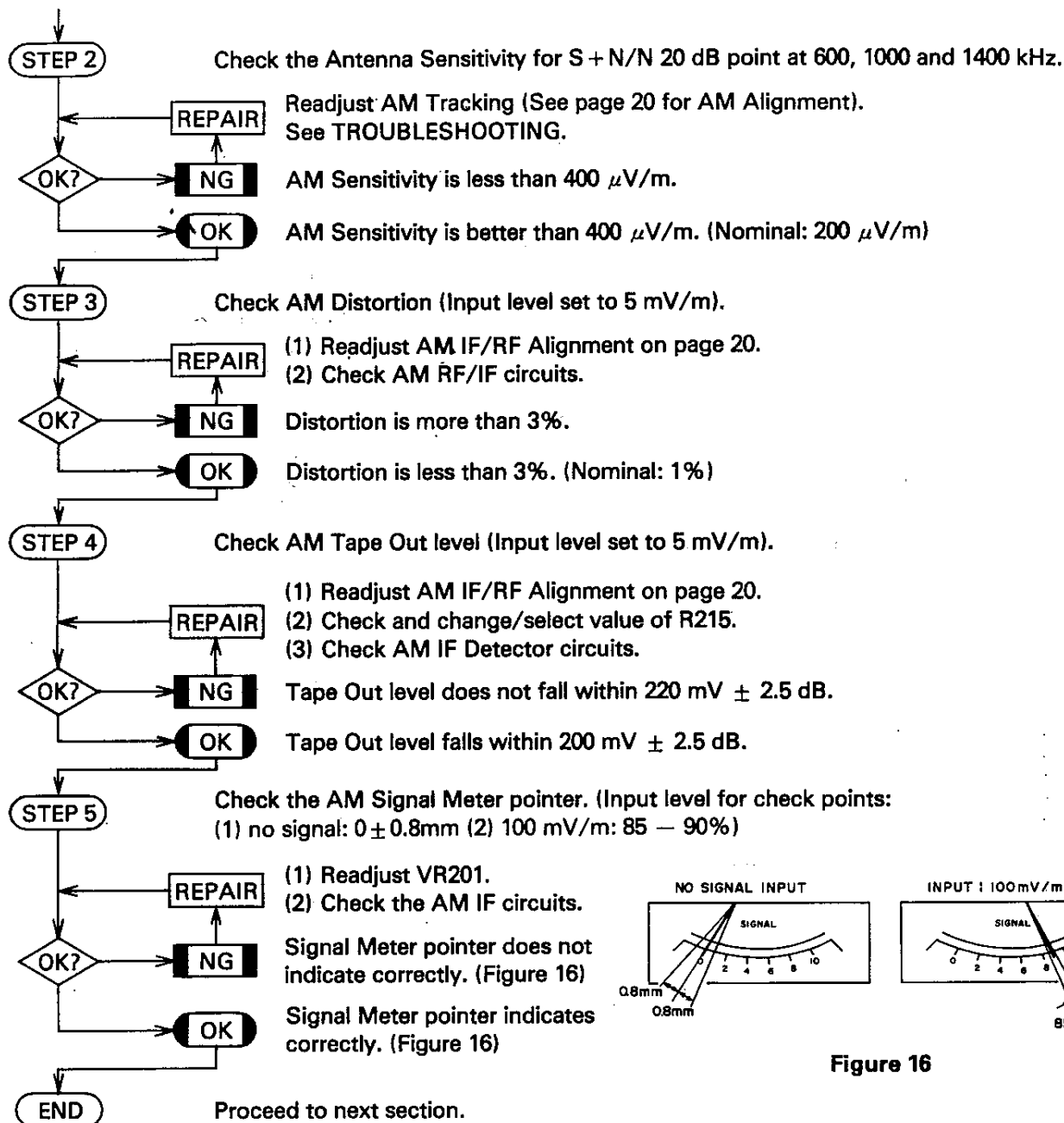


Figure 16

(2) FM RF/IF OPERATION CHECK

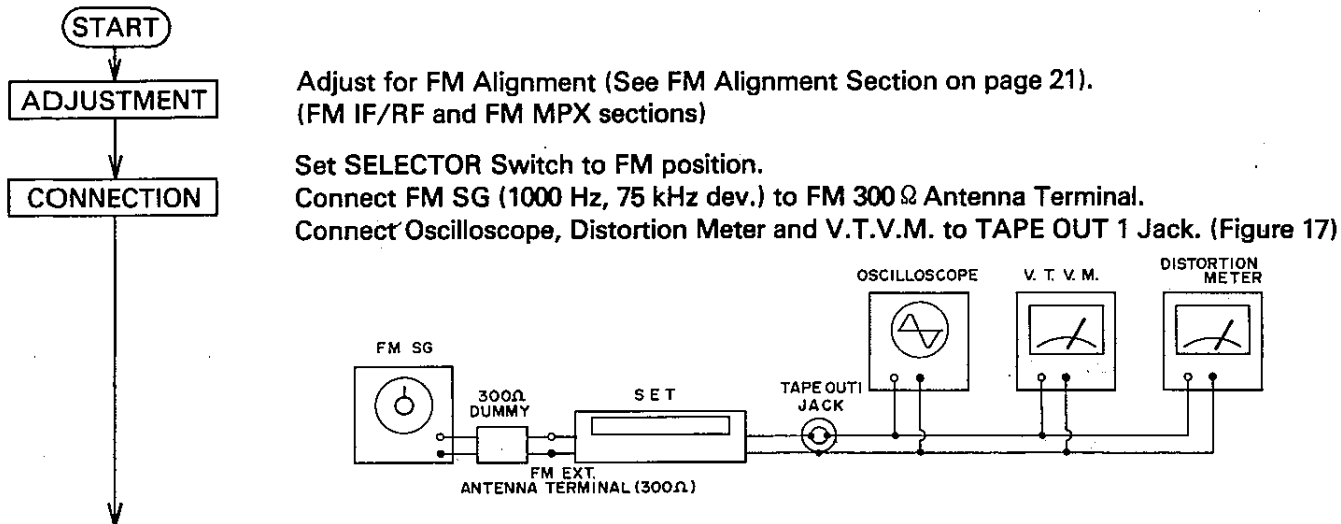
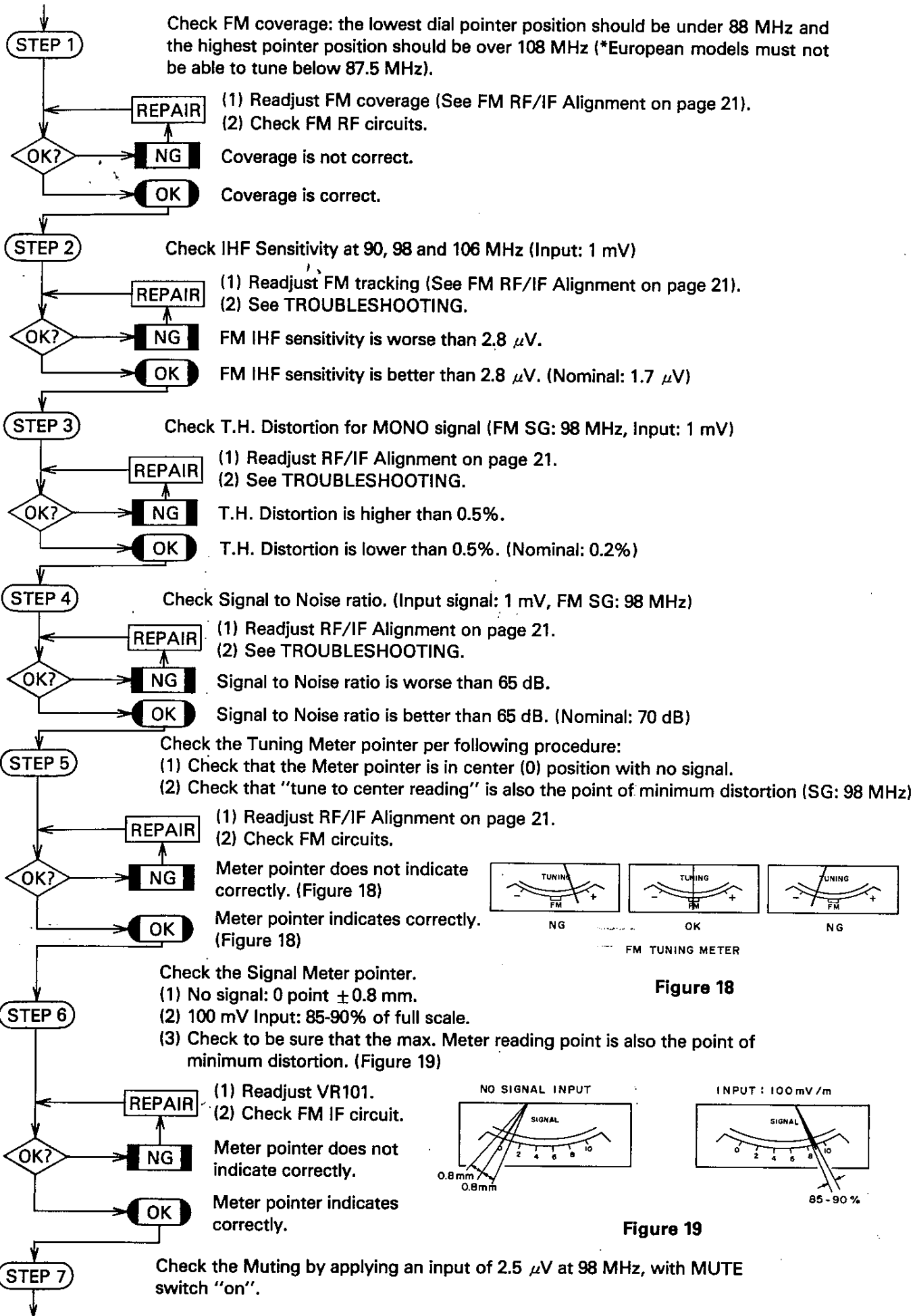


Figure 17



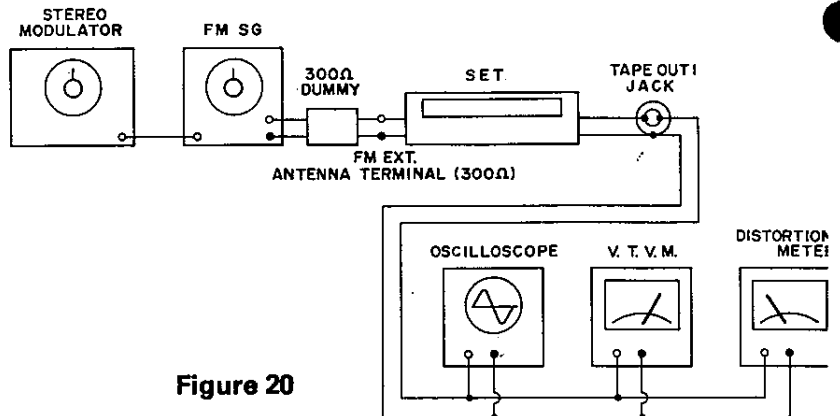
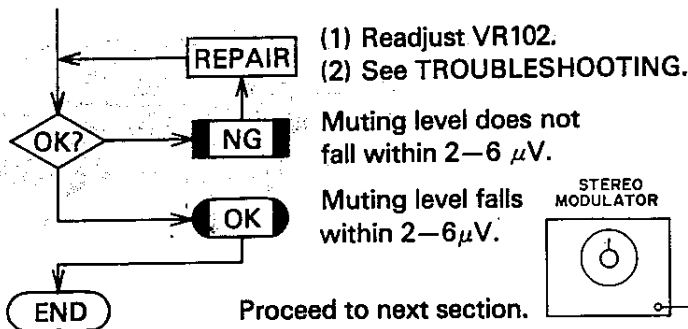
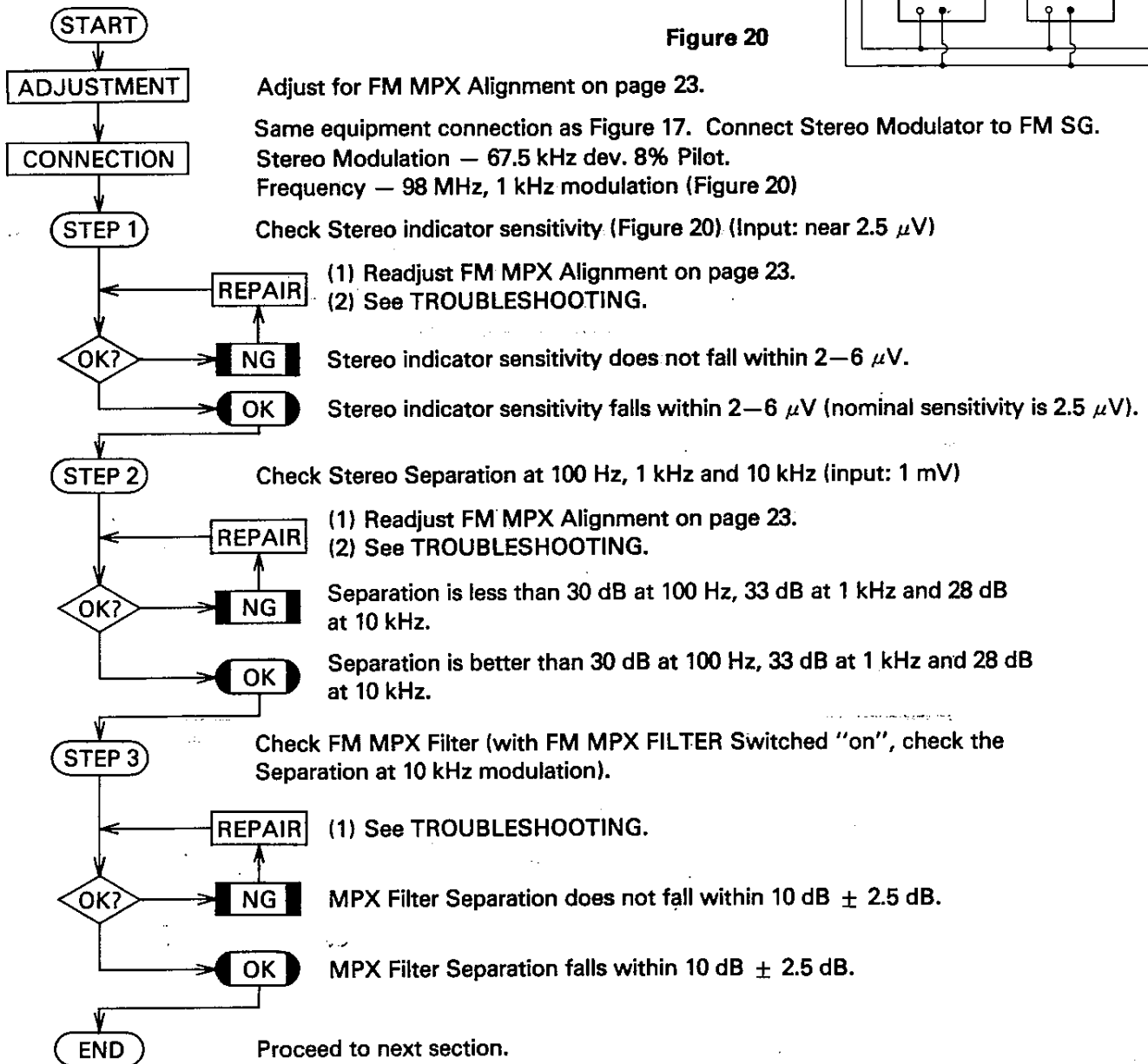


Figure 20

(3) FM MPX OPERATION CHECK



7) ALIGNMENT INSTRUCTIONS

AUDIO CIRCUIT ADJUSTMENT/CHECK

EQUIPMENT REQUIRED

1. DC Voltmeter
2. Audio Oscillator
3. Oscilloscope
4. AC Voltmeter

Notes:

- Maintain voltage at 120 volts AC, 60 Hz (UL, C.S.A.)
(Use 220/240 volts AC, 50 Hz for European & 240 volts AC, 50 Hz for Australian models).
- Set SELECTOR Switch to AUX.
- Set MODE Switch to STEREO.
- See P.C.B. illustration for alignment points/adjustments.

For location of connection points and trimmer resistors, see P.C.B. view.

MAIN AMP ADJUSTMENT

STEP	ADJUSTMENT	EQUIPMENT	CONNECTION	AUDIO FRE.	LEVEL	ADJUSTMENT
1	Check Balance by measuring DC voltage across OUTPUT TERMINAL of L and R channel.	DC Volt Meter	See Fig. 21.	No signal	DC voltage should be less than 50 mV.	—
2	Idling current adjustment	DC Volt Meter	See Fig. 22.	No signal	Adjust voltage across Emitter resistors R519A (L ch) and R519B (R ch) to 10 mV (8 ohm load)	VR501A (L ch) VR501B (R ch) See Fig. 23

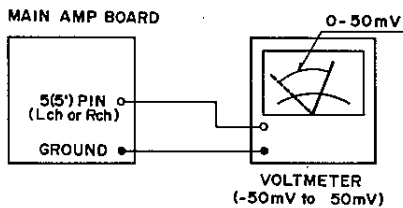


Figure 21

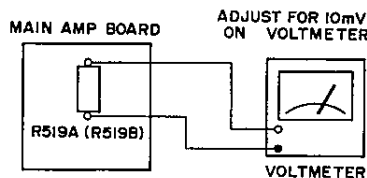


Figure 22

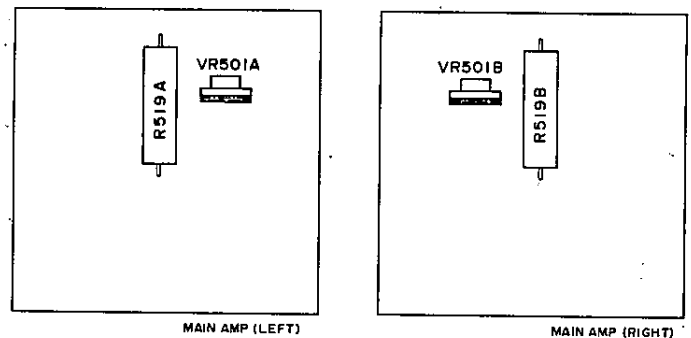


Figure 23

For location of connection points and trimmer resistors, see P.C.B. view.

WATT METER ADJUSTMENT

STEP	ADJUSTMENT	EQUIPMENT	CONNECTION	AUDIO FREQ.	SETTING	LEVEL	ADJUSTMENT
1	WATT Meters level adjustment	Audio Osc. V.T.V.M. Oscilloscope	See Fig. 24	1000 Hz	VOLUME: Max. BASS MID., TRE- BLE, BAL- ANCE: center	Adjust input to AUX to get output level of 28.3 V (100W) (no load.)	VR701 (L ch) VR702 (R ch) so the WATT Meters indicate 100 W.

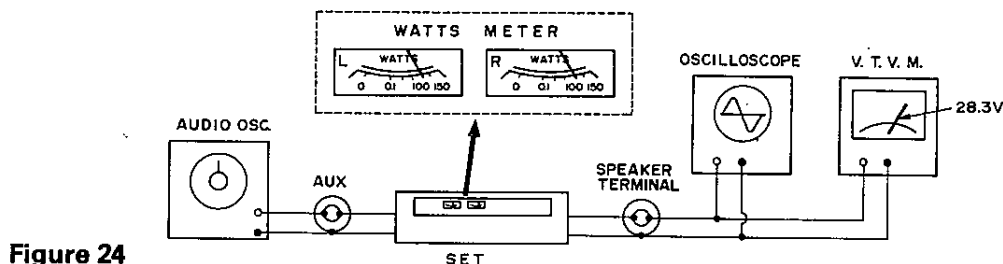


Figure 24

AM IF & RF ALIGNMENT

EQUIPMENT REQUIRED

1. AM Signal Generator
2. AC Voltmeter
3. Oscilloscope
4. Standard Loop Antenna

- Notes**
- Signal generator output should be no higher than necessary to obtain an output reading.
 - Maintain voltage at 120 volts AC, 60 Hz (UL, C.S.A.)
(Use 220/240 volts AC, 50 Hz for European & 240 volts AC, 50 Hz for Australian models)
 - Set SELECTOR Switch to AM.
 - Set BASS, MID., TREBLE and BALANCE to Center.
 - See P.C.B. illustrations for alignment points/adjustments.

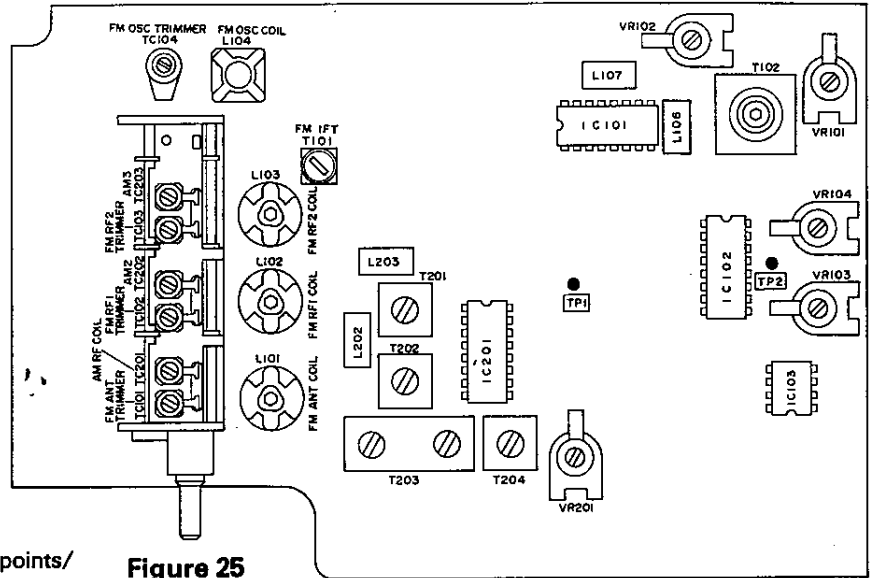


Figure 25

STEP	GENERATOR COUPLING	GENERATOR FREQUENCY	DIAL SETTING	INDICATOR	ADJUSTMENT	REMARKS
1	Connect standard loop antenna to Signal Generator and radiate signal into the AM Ferrite antenna. See Fig. 26.	455 kHz (400 Hz, 30% Mod.)	Point of non-interference (near 600 kHz)	AC Voltmeter to TAPE OUT 1 Jack	T203 (Both sections) T204	Adjust for maximum reading on meter. Refer to Fig. 25 & 26.
2	Same as STEP 1	515 kHz (400 Hz, 30% Mod.)	Tuning Gang fully closed.	Same as STEP 1	T201	Adjust for maximum reading on meter. Refer to Fig. 25 & 26.
3	Same as STEP 1	1650 kHz (400 Hz, 30% Mod.)	Tuning Gang fully opened.	Same as STEP 1	TC202 (AM 2)	Adjust for maximum reading on meter. Refer to Fig. 25 & 26.
4	Repeat STEPs 2 & 3 until no further change is noticed.					
5	Same as STEP 1	600 kHz (400 Hz, 30% Mod.)	600 kHz	Same as STEP 1	L901 (AM ANT coil) T202 (AM RF Coil)	Adjust for maximum reading on meter. Refer to Fig. 25 & 26.
6	Same as STEP 1	1400 kHz (400 Hz, 30% Mod.)	1400 kHz	Same as STEP 1	T201 (AM 1) T203 (AM 3)	Adjust for maximum reading on meter. Refer to Fig. 25 & 26.
7	Repeat STEPs 5 & 6 until no further change is noticed.					
8	Same as STEP 1	1000 kHz (400 kHz, 30% Mod.), Output level to 100 mV/m	1000 kHz	Meter on set	VR201	Adjust so the Meter Pointer on Receiver is between 85% and 90% on meter. Refer to Fig. 25 & 26.

AM ALIGNMENT SET-UP

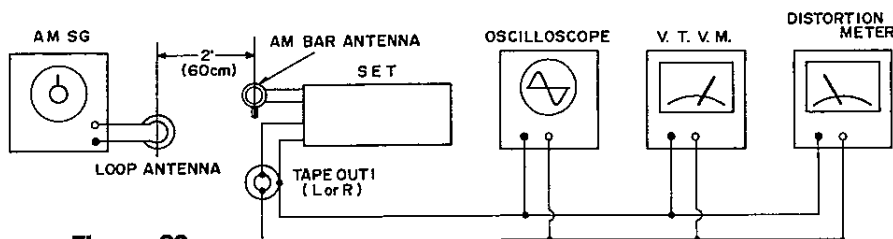


Figure 26

FM RF & IF ALIGNMENT

EQUIPMENT REQUIRED

1. FM Signal Generator
2. AC Voltmeter
3. Oscilloscope
4. Distortion Meter

- Notes:**
- Signal Generator output should be no higher than necessary to obtain an output reading.
 - Maintain Line voltage at 120 volts AC, 60 Hz (UL, C.S.A.) (Use 220/240 volts AC, 50 Hz for European & 240 volts AC, 50 Hz for Australian models.)
 - Set SELECTOR Switch to FM.
 - Set MODE Switch to Stereo.
 - Refer to P.C.B. illustrations for test points/adjustments.

STEP	GENERATOR COUPLING	GENERATOR FREQUENCY	DIAL SETTING	INDICATOR	ADJUSTMENT	REMARKS
1	Signal Generator to FM Antenna Terminal thru FM Dummy Antenna (300 ohm)	98 MHz (1 kHz, 75 kHz dev.) Input: no input (unit off)	Near to 98 MHz	Tuning Meter	T102 (Primary)	Adjust for Center Point on TUNING Meter. Refer to Fig. 27, 28 and 29.
2	Same as STEP 1	98 MHz (1 kHz, 75 kHz dev.) Input: 1 mV	Same as STEP 1	AC Voltmeter Scope and Distortion Meter to TAPE OUT 1 Jack (L or R)	T102 (Secondary)	Adjust for minimum Distortion (about 0.1%) Refer to Fig. 27, 28 and 29.
3	Repeat STEPs 1 and 2 until no further improvement is noticed.					
4	Same as STEP 1	90 MHz (1 kHz, 75 kHz dev.) Input: about 2 — 3 μ V	90 MHz	Same as STEP 2	L101 (FM Antenna Coil) L102, L103 (FM 1st & 2nd RF Coil) L104 (FM OSC. Coil)	Adjust for maximum reading on meter. Refer to Fig. 25 and 29.
5	Same as STEP 1	106 MHz (1 kHz, 75 kHz dev.) Input: about 2 — 3 μ V	106 MHz	Same as STEP 2	TC101 (FM Antenna Trimmer) TC102, TC103 (FM 1st & 2nd RF Trimmer) TC104 (FM OSC Trimmer)	Adjust for maximum reading on meter. Refer to Fig. 25 and 29.
6	Repeat STEPs 4 and 5 until no further improvement is noticed.					
7	Same as STEP 1	98 MHz (1 kHz, 75 kHz dev.) Input: 2 - 3 μ V	98 MHz	Same as STEP 2	T101 (FM IFT) (IF & TUNER P.C.B.)	Adjust for maximum reading on meter. Refer to Fig. 25 and 29.

STEP	GENERATOR COUPLING	GENERATOR FREQUENCY	DIAL SETTING	INDICATOR	ADJUSTMENT	REMARKS
8	Repeat STEP 7 until no further improvement is obtained. Go back and check STEPs 1 and 2 and realign if necessary.					
9	Same as STEP 1	98 MHz (1 kHz, 75 kHz dev.) Input: 2.5 μ V	98 MHz	Same as STEP 2	VR101	"MUTE" switched "ON" and adjust VR102 for no signal output.
10	Same as STEP 1	98 MHz (1 kHz, 75 kHz dev.) Input: 100 mV	98 MHz	SIGNAL Meter	VR102	Adjust so the Meter Pointer on Receiver is 90-95% of full scale.
11	Same as STEP 1	98 MHz (1 kHz, 75 kHz dev.) Input: 100 mV	98 MHz	TUNING, SIGNAL Meter.	—	With "tune to center" for TUNING and maximum on Signal Meter, Distortion Meter should indicate minimum.

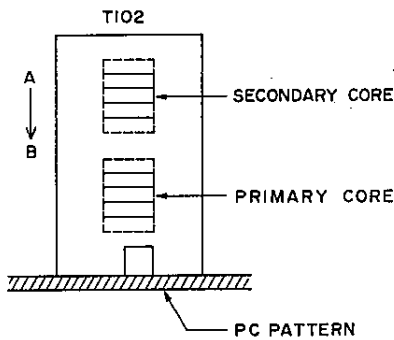
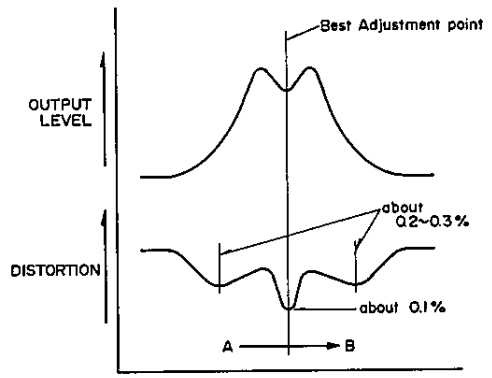


Figure 27



CORE TURNING DIRECTION
(CLOCKWISE / DOWNWARDS)
(T102) (From "A" to "B" on Figure 27)

Figure 28

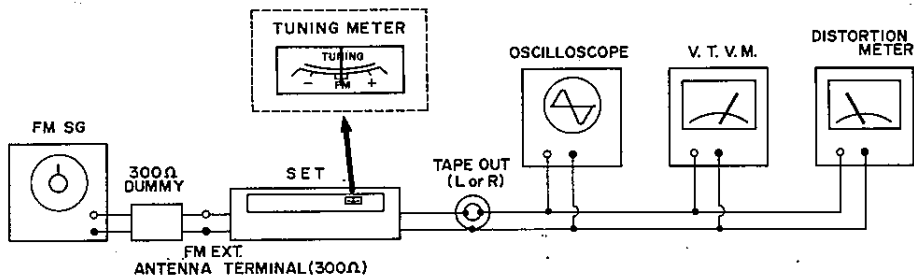


Figure 29

FM STEREO ALIGNMENT

EQUIPMENT REQUIRED

1. Stereo Modulator: Connect Stereo Modulator to EXT. Mod. terminal FM Signal Generator. Modulation level of 19 kHz Pilot Signal 8% (6 kHz dev.)
2. FM Signal Generator: Output Level 1 mV
Frequency Approximately 98 MHz
Deviation 67.5 kHz, 90% modulation composite signal
3. Audio Generator
4. AC Voltmeter
5. Oscilloscope
6. Distortion Meter
7. Frequency Counter

Notes:

- See P.C.B. illustration for alignment/test points.
- Set SELECTOR switch to FM, MODE switch to STEREO and MUTE switch to "off" position.

MULTIPLEX & SEPARATION ALIGNMENT

STEP	SIGNAL GENERATOR COUPLING	STEREO MODULATION	INDICATOR	ADJUSTMENT	REMARKS
1	Connect to FM Antenna terminal thru FM dummy antenna (300 ohm)	Mono. 1 kHz (1000 Hz, No Mod.) Input: 1 mV	Counter connected to TP2 of IF & MPX Board (Pin 12 of IC102)	VR104	Adjust for 19 kHz \pm 50 Hz on Counter. Refer to Fig. 30.
2	Same as above	Composite MPX Signal 1 kHz on Left channel ONLY	AC Voltmeter connector for TAPE OUT 1 Jack of Right channel	VR103 (Separation)	Adjust for minimum reading on Meter. Refer to Fig. 31.
3	Same as above	Composite MPX Signal 1 kHz on Right channel ONLY	AC Voltmeter connector for TAPE OUT 1 Jack of Left channel	Same as above	Same as above
4	Repeat STEPS 2 and 3 until AC Voltmeter reading is at least -33 dB re-same channel output. (ie. 33 dB separation)				
5	Same as STEP 1	Composite MPX Signal 1 kHz	AC Voltmeter connected to TAPE OUT 1 Jack	—	With 2-6 μ V antenna input signal, Stereo indicator lamp should come on.
6	Same as STEP 1	Composite MPX Signal 1 kHz	Distortion Meter Connected to TAPE OUT 1 Jack	—	With 1 mV antenna input signal, Stereo Distortion should be less than 0.7%.

FM STEREO ALIGNMENT SET-UP

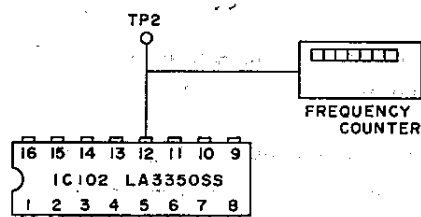


Figure 30

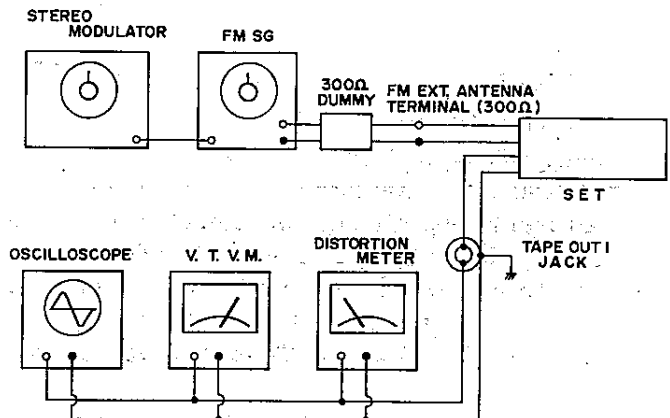


Figure 31

8) BRIEF DESCRIPTION OF PROTECTOR CIRCUITS

(1) PROTECTIVE CIRCUIT IN CASE OF SHORTED OUTPUT TERMINALS

If speaker terminals are shorted (or load impedance of one channel is less than 4 ohms), excessively high current flows from emitter to collector of TR510A (TR510B) and a high voltage appears across R520A (R520B). TR511A (TR511B) will turn on and this high voltage goes to gate of SCR701 after being rectified by D506A (506B). When the voltage between cathode and gate increases to about 0.7 V, SCR701 will turn on. TR702 and TR703 will then turn on, and TR704 and TR705 will turn off.

Relay RY701 and RY702 will shut off output to the speaker terminals and output will drop to zero. Thus Main Amp. and Speaker will be protected. Turn the Receiver off to reset the protective circuit. Wait approximately 5 seconds. When the problem is corrected, turn the Receiver on again. (See Figure 32)

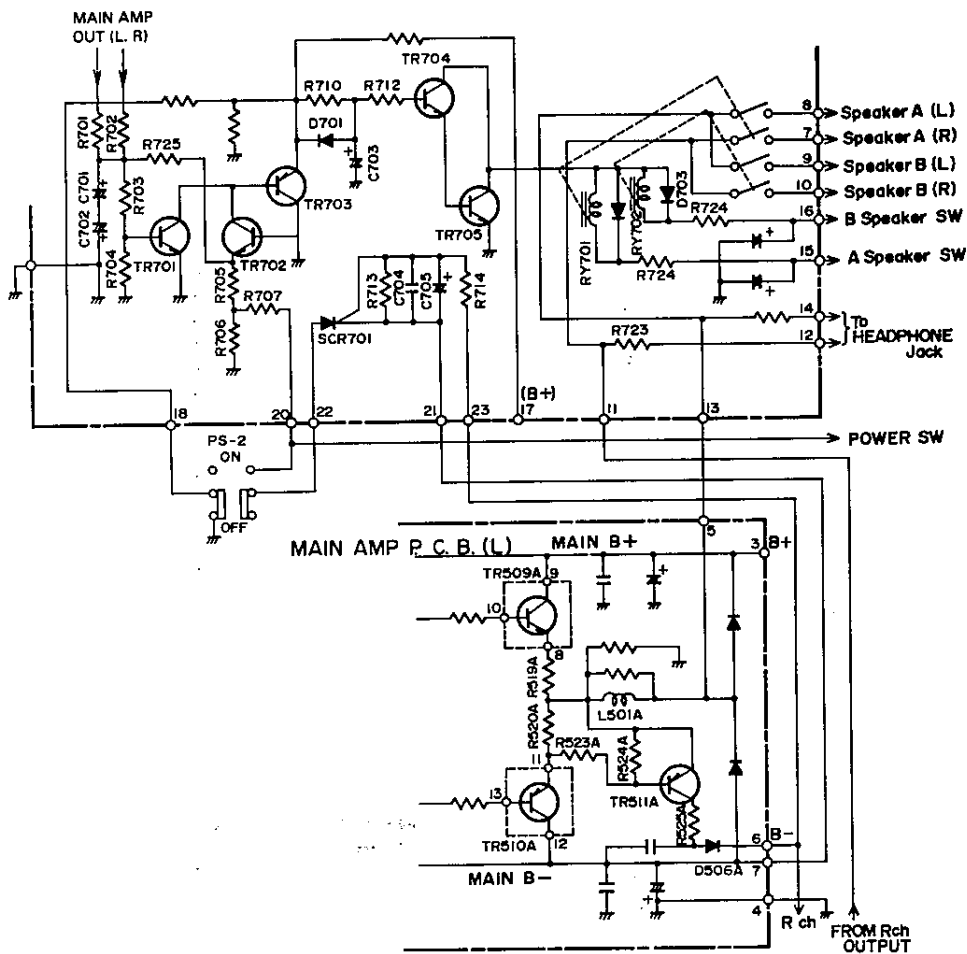


Figure 32

(2) MAIN AMP PROTECTIVE CIRCUIT

If center voltage of Main Amp goes to ± 3.5 V (normal condition within ± 50 mV), TR701 or TR702 and TR703 will turn on and TR704 and TR705 will turn off. If this should occur, Relay RY701 and RY702 will shut off output to the speaker terminals and output will drop to zero, protecting Main Amp and Speaker. (See Figure 32)

NOTE: To prevent AC voltages from upsetting these circuits, capacitors C701 and C702 have been incorporated. If AC voltage is applied to the base of TR701, it will be grounded through C701 and C702; thus, TR701 is immune to AC voltages.

9) TROUBLESHOOTING

SYMPTOM	CAUSE/REMEDY
1) No output	<ol style="list-style-type: none"> 1. Faulty AC power cord *Replace the cord. 2. Defective POWER switch *Replace the switch. 3. Broken wire in the Power Transformer *Replace the Transformer. 4. Blown Primary Fuse *Replace the Fuse. 5. Defective D901 or diodes, transistors on Power Supply board (TR601-603) *Replace the defective part(s).
2) Dial Lamp does not light for SELECTOR. (AM, FM, PHONO 1, PHONO 2 or AUX)	<ol style="list-style-type: none"> 1. Defective Lamp *Replace the Lamp. 2. Open Power Transformer tertiary winding *Replace the Transformer. 3. Blown Fuse in tertiary winding (2.5 A) F902 *Replace the fuse.
3) Dial Lamp lights but no Speaker output.	<ol style="list-style-type: none"> 1. Defective capacitor C908 or C909 *Replace the defective capacitor(s). 2. Defective Rectifier D901 *Replace the defective Rectifier. 3. Defect in the Power Transformer secondary winding *Replace the Power Transformer. 4. Defective RY701 or RY702 on Protector Board *Replace the part(s).
4) Blows Fuse.	<ol style="list-style-type: none"> 1. Defective Rectifier D901 *Replace the Rectifier. 2. Short circuit in the rectifier circuit *Remove the short. 3. Short circuit in Power Transistor Circuitry TR506A-511A or TR506B-TR511B *Repair circuit and/or replace the defective Transistor. 4. Defective RY701, 702 or Transistors on Protector board *Replace the part(s).
5) "A" Speakers do not work.	<ol style="list-style-type: none"> 1. Speaker switch A defective *Replace the switch.
6) "B" Speakers do not work.	<ol style="list-style-type: none"> 1. Speaker switch B defective *Replace the switch.
7) No output one channel with VOLUME at maximum and BALANCE at center, when a test signal is applied to the terminal of non-operating channel of the BALANCE control (VR403/VR404)	<ol style="list-style-type: none"> 1. Defective Transistor TR403-411, 501A-511A or TR501B-511B *Replace the defective Transistor(s). 2. Defective resistor or capacitor in TONE, MAIN AMP or PROTECTOR circuit *Replace the defective part(s).
8) No output when a test signal is applied to the input terminals except PHONO 1 or 2.	<ol style="list-style-type: none"> 1. Defective MONO-Stereo or TAPE switch *Replace or repair the switch. 2. Defective Selector switch *Replace the switch.

SYMPTOM	CAUSE/REMEDY
9) No output when a test signal is applied to the PHONO 1 input terminals.	1. Defective transistor, resistor or capacitor in PRE AMP circuit *Replace the part(s). 2. Defective MONO-Stereo or TAPE switch *Replace or repair the switch. 3. Defective Selector switch *Replace the Selector switch.
10) No output when a test signal is applied to the PHONO 2 input terminals.	1. Defective transistor, resistor or capacitor in PRE AMP circuit *Rplace the part(s). 2. Defective MONO-Stereo or TAPE switch *Replace or repair the switch. 3. Defective Selector switch *Replace the Selector switch.
11) No output when a test signal is applied to the desired input.	1. Defective transistors or diodes on Power Supply board *Replace the defective part(s). 2. Defective transistor, resistor or capacitor on Tone Control board *Replace the defective part(s). 3. Defective transistor, capacitor or resistor on Main Amp board *Replace the defective part(s).
12) DC not balanced within ± 50 mV at output of L/R channel.	1. Defective TR501A, 502A, 503A or TR501B, 502B, 503B. *Replace the defective transistor(s).
13) Speaker works normally but Head-phone does not work.	1. Defective R715 (Left) or R716 (Right) *Change it. 2. Headphone plug does not mate with jack *Replace the plug.
14) All the inputs work normally except "AUX" input.	1. Poor contact in "AUX" input jack *Repair or replace it. 2. Poor contact in Selector switch *Repair or replace the switch.
15) "PHONO 1" input not operative.	1. Poor contact in "PHONO 1" input jack *Repair or replace it. 2. Faulty Selector switch *Repair or replace it. 3. Faulty PHONO Level switch *Replace the switch.
16) "PHONO 2" input not operative.	1. Poor contact in "PHONO 2" input jack *Repair or replace it. 2. Faulty Selector switch *Repair or replace it.
17) "TAPE OUT 1" inoperative.	1. Poor contact in "TAPE OUT 1" output jack *Repair or replace the jack.
18) "TAPE IN 1" inoperative.	1. Poor contact in "TAPE IN 1" input jack *Repair or replace the jack.

SYMPTOM	CAUSE/REMEDY
19) "TAPE OUT 2" inoperative.	1. Poor contact in "TAPE OUT 2" output jack *Repair or replace the jack.
20) "TAPE IN 2" inoperative.	1. Poor contact in "TAPE IN 2" input jack *Repair or replace the jack.
21) No AM or FM (Tuner B+ voltage is not 12.6 V.)	1. Broken tertiary winding in the Power Transformer *Replace the Transformer. 2. Defective Diode D602 *Change the Diode. 3. Faulty capacitor C625-C629 *Change the defective capacitor(s). 4. Defective resistor R611-R614 *Replace the resistor(s). 5. Zener Diode D605 defective *Replace the Diode. 6. Short-circuit in Tuner B+ circuit *Repair the short. 7. Poor contact in Selector switch *Repair or replace it. 8. Defective Transistor TR603 *Replace the Transistor.
22) No FM	1. Poor contact in Selector switch *Repair or replace it. 2. IC, Transistor, Diode, resistor, capacitor, Inductor or IFT of FM IF board or FM Front End defective *Replace the defective part(s). 3. Faulty FM Antenna lead-in/circuitry *Replace or repair the Antenna lead-in/circuitry.
23) No AM	1. Poor contact in Selector switch *Repair or replace switch. 2. IC, Transistor, Diode, IFT, resistor or capacitor of AM IF defective *Replace the defective part(s). 3. Bar-Antenna coil defective *Repair or replace it.
24) Poor FM sensitivity.	1. Defective TR101-103 or 104-106 *Replace the defective Transistor(s). 2. Defective IC101 or 102 *Replace the defective IC(s). 3. Defective ceramic filter CF101, 102 or 103 *Replace the defective ceramic filter(s). 4. Defective L101-L104 or T101 *Replace the defective coil(s).
25) Poor FM distortion.	1. Defective T101, 102 *Replace the defective detector coil. 2. Defective ceramic filter CF101, 102, 103 *Replace the defective filter(s). 3. Defective IC IC101, 102 *Replace the defective IC(s). 4. Defective L106, 107 *Change the defective part(s).
26) Poor AM sensitivity.	1. Defective L901, T201, 202, 203, 204 *Replace the defective part(s). 2. Defective IC201 *Replace the defective IC.

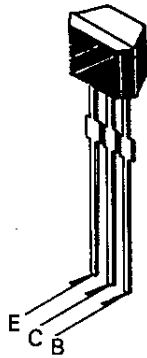
SYMPTOM	CAUSE/REMEDY
27) No FM MPX Separation	1. Improper adjustment *Readjust VR103 and VR104 2. IC205 of MPX board defective *Replace the IC. 3. VR103, 104 (Trimmer resistor) defective *Replace the Trimmer resistor(s). 4. Defective Transistor TR109 *Replace the defective Transistor
28) No STEREO light or FM Stereo does not work.	1. Defective STEREO indicator lamp *Replace the lamp. 2. Defective IC102 of MPX board *Change the defective IC. 3. Defective Transistor TR109 *Replace the Transistor. 4. VR103, 104 defective *Replace the defective Trimmer resistor(s).
29) "LOUDNESS" has no effect.	1. Defective "LOUDNESS" switch *Replace the switch. 2. Defective C801, 803, R801 or C802, 804, R802 *Replace the defective part(s).
30) "Stereo-MONO" not effective.	1. Defective Stereo-MONO "MODE" switch *Repair or replace the switch.
31) "FM MUTE" not effective.	1. Defective MUTE switch *Repair or replace the switch. 2. Defective Transistor TR309, 310, 311, 312 *Replace the defective Transistor(s). 3. Defective Trimmer resistor VR102 *Replace the Trimmer resistor. 4. Defective part(s) on MUTING board *Replace the part(s).
32) "HI MPX FILTER" not effective.	1. Defective HI MPX FILTER switch *Repair or replace the switch. 2. Defective C144 or R185 *Replace the defective part(s).
33) "TAPE DUBBING 1-2" does not operate.	1. Defective TAPE DUBBING switch *Replace it.
34) "TAPE DUBBING 2-1" does not operate.	1. Defective TAPE DUBBING switch *Replace it.
35) "TAPE MONITOR 1" does not operate.	1. Defective TAPE MONITOR switch *Replace it.
36) "TAPE MONITOR 2" does not operate.	1. Defective TAPE MONITOR switch *Replace it.

SYMPTOM	CAUSE/REMEDY
37) "BASS" has no effect.	1. VR409 (100K ohm control) defective *Replace it. 2. Defective R433, 435, 437, 439, C425, 427 or R434, 436, 438, 440, C426, 428 *Replace the defective part(s).
38) "MIDRANGE" has no effect.	1. VR407 (200K ohm control) defective *Replace it. 2. Defective R449, 451, 453, 455, 457, C435, 437 or R450, 452, 454, 456, 458, C436, 438 *Replace it the defective parts.
39) "TREBLE" has no effect.	1. Faulty VR405 (100K ohm control) *Replace it. 2. Defective R427, 429, 431, 433, C419, 421, or R428, 430, 432, 434, C420, 422 *Replace the defective part(s).
40) "TONE DEFEAT" has no effect.	1. Defective "TONE DEFEAT" switch *Replace the switch. 2. Defective R441, 442, 443, 444 *Replace the defective part(s).
41) WATTs Meter does not work.	1. Defective WATT Meter L or/and R *Repair or replace the Meter. 2. Defective Diode, capacitor or resistor of Meter circuit *Replace the defective part(s). 3. Defective Trimmer resistor VR701 or 702 *Replace the defective Trimmer resistor.
42) PROTECTOR circuit does not work.	1. Defective resistor or capacitor in PROTECTOR circuit *Replace the defective part(s). 2. Defective Diode D506A, 506B, 701 *Replace the defective Diode(s). 3. Defective Transistor TR511A, 511B, 701, 702, 703, 704, 705 *Replace the defective Transistor(s). 4. Defective RY701 or 702 *Replace the defective part(s).
43) "SIGNAL" Meter not functioning.	1. Defective SIGNAL Meter *Replace it. 2. In case of FM reception, D102, 103, 106-108, TR107, 108, VR101 defective *Replace the defective part(s). 3. In case of AM reception, VR201 defective *Replace the defective part.
44) "TUNING" Meter not functioning.	1. Defective TUNING Meter *Replace it. 2. Defective R151 or C140 *Replace the defective part(s).
45) "HIGH FILTER" has no effect.	1. Defective "HIGH FILTER" switch *Replace the switch. 2. Defective C805 or C806 *Replace the defective part(s).

10) IC & TRANSISTOR LEAD IDENTIFICATION



03P-1M



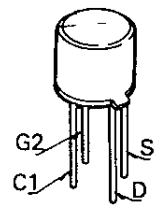
2SC 2786
2SC 2787



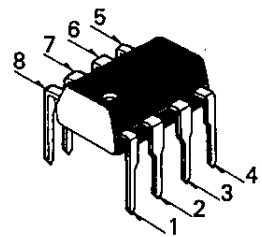
2SC 945A
2SC 1674
2SC 1222
2SC 1675
2SA 733A
2SA 750
2SA 992



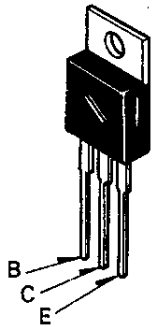
2SD 571
2SC 1941
2SA 916



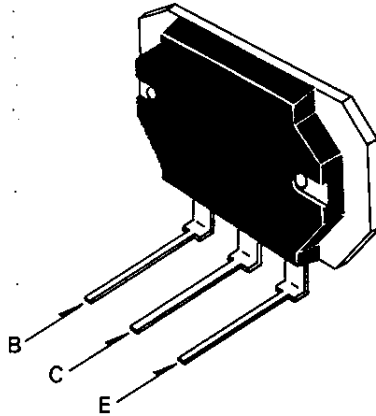
3SK45



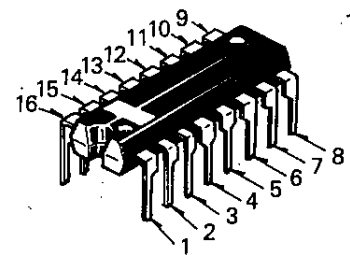
NJM-4558



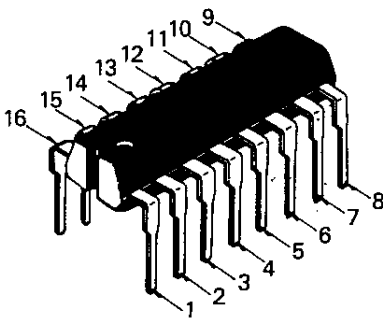
2SA 985
2SB 511
2SC 2275
2SD 325
2SD 330



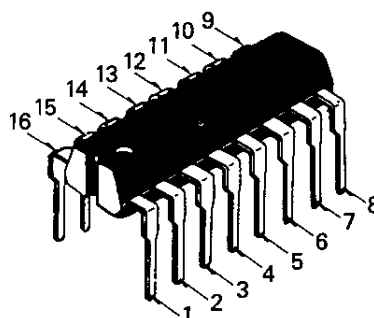
2SB 705
2SD 745



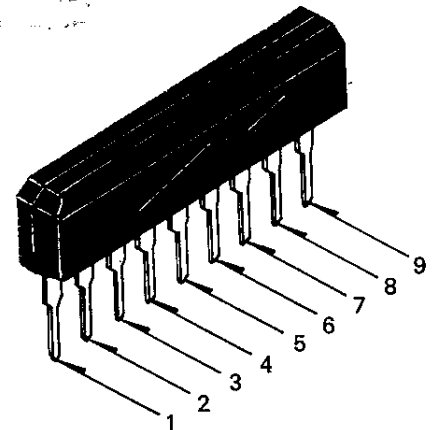
HA 1197



LA1231N



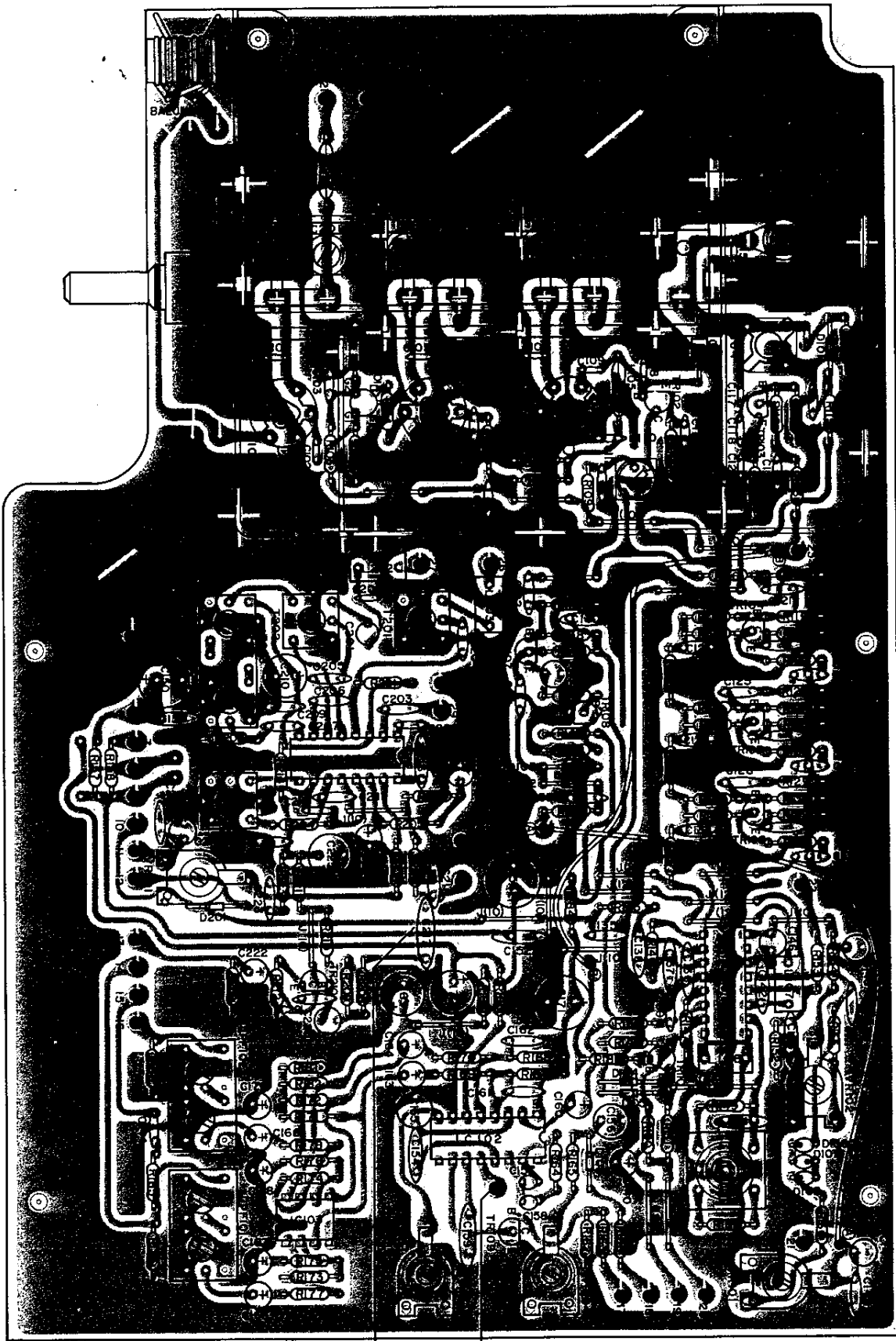
LA 3350



TA 7318P

11) IF & TUNER P.C.B. (TOP & BOTTOM VIEWS)

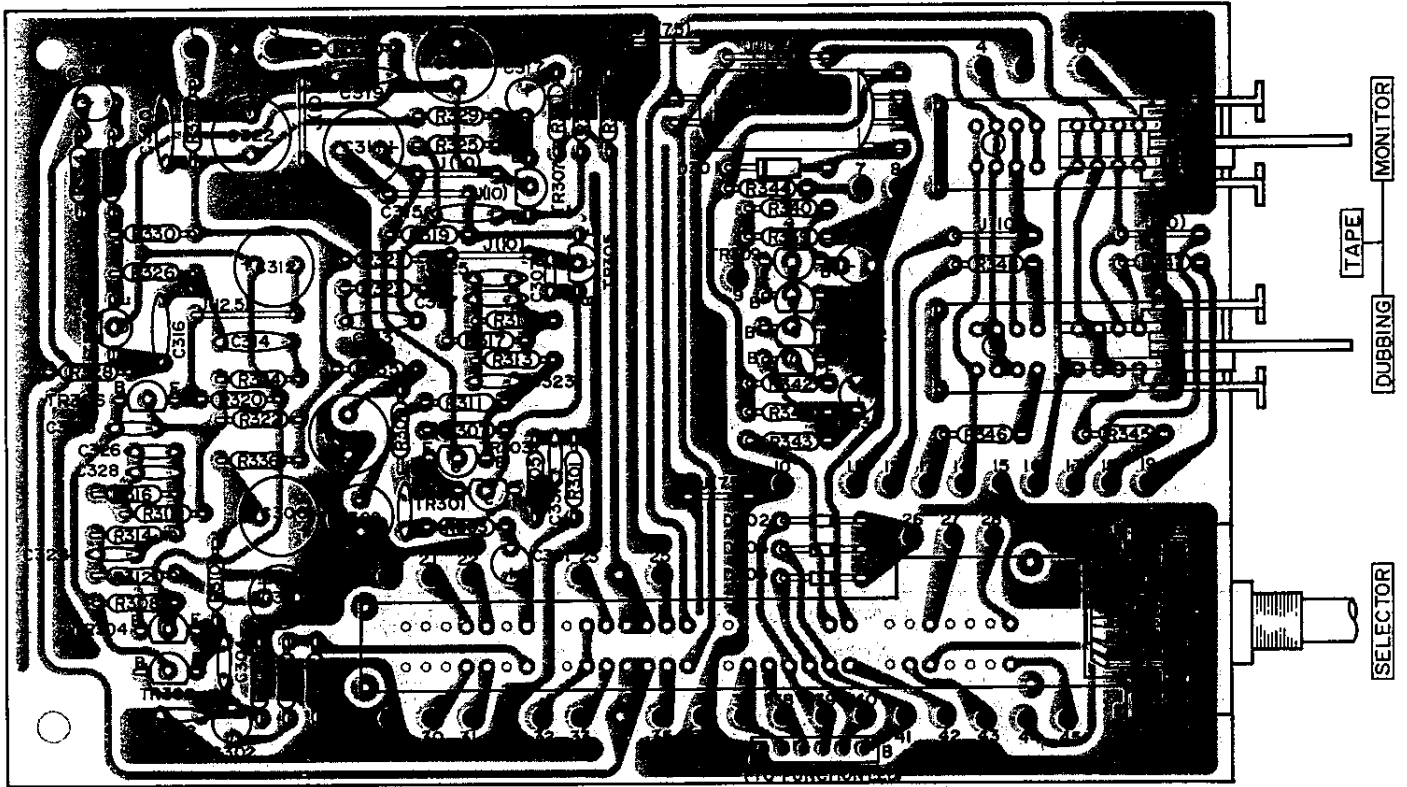
TOP VIEW



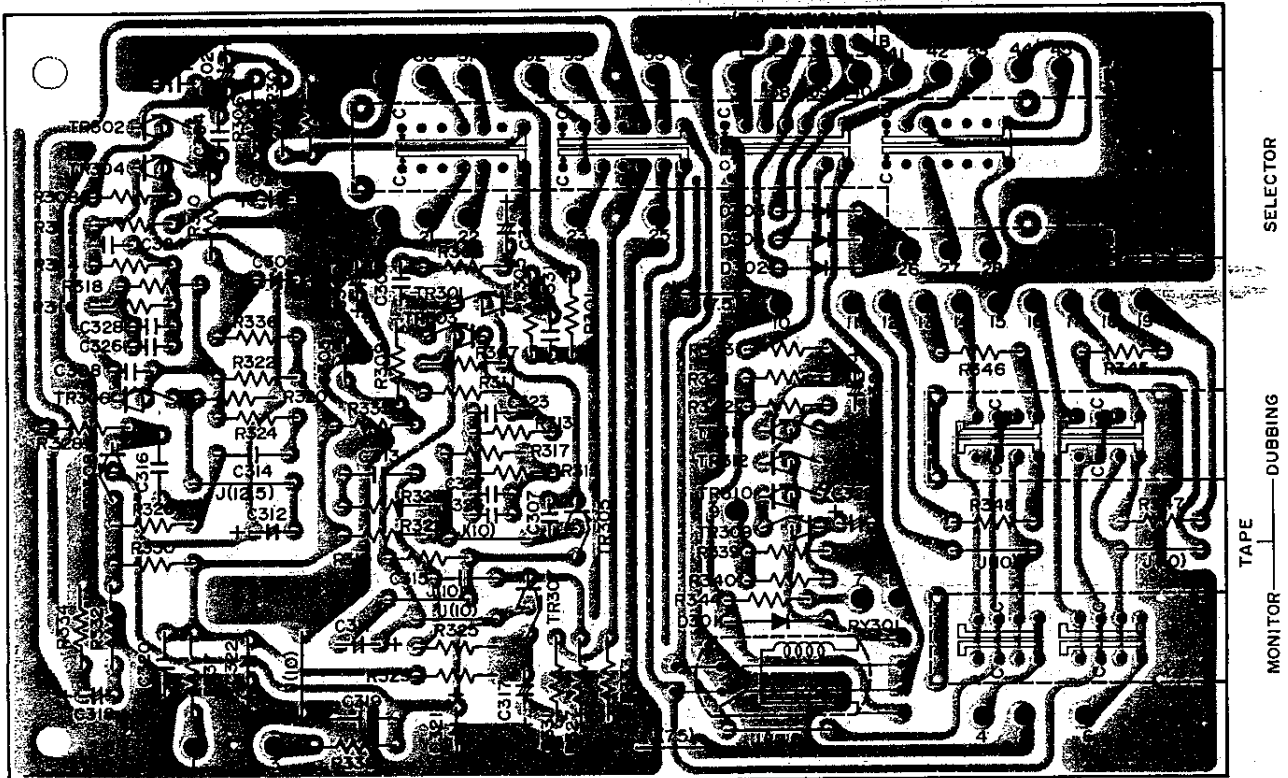
TP1
TP2

12) PRE AMP P.C.B. (TOP & BOTTOM VIEWS)

TOP VIEW

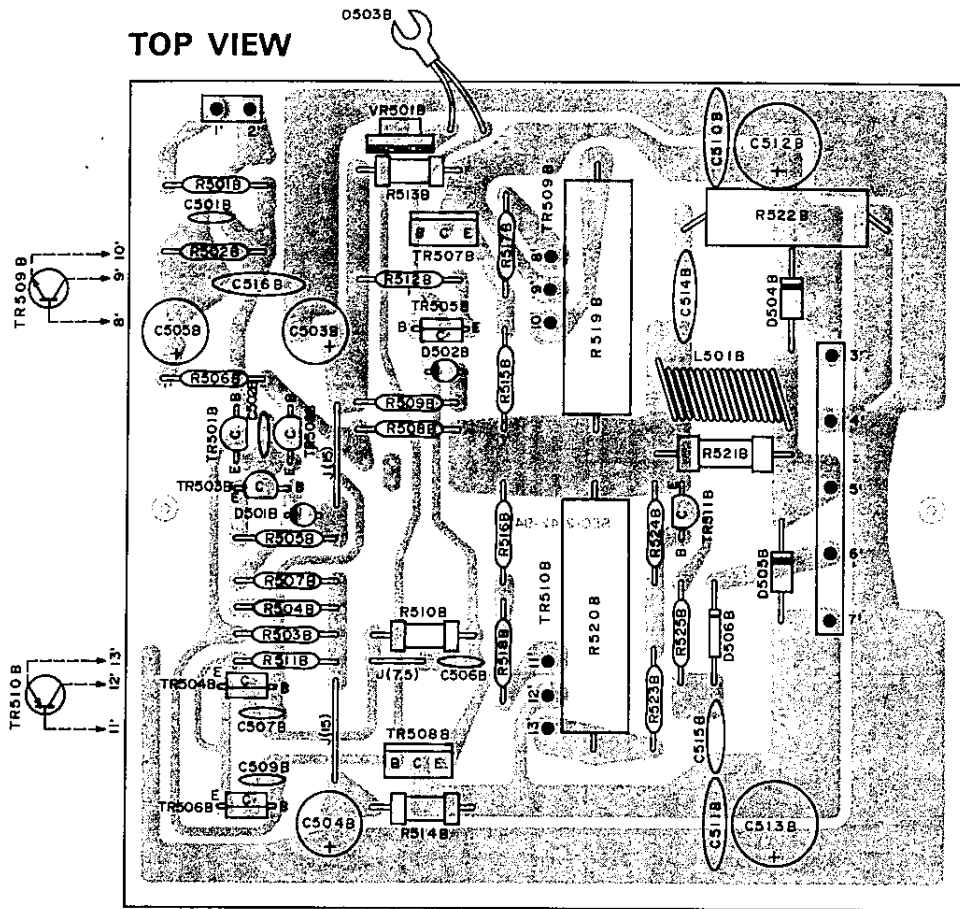


BOTTOM VIEW

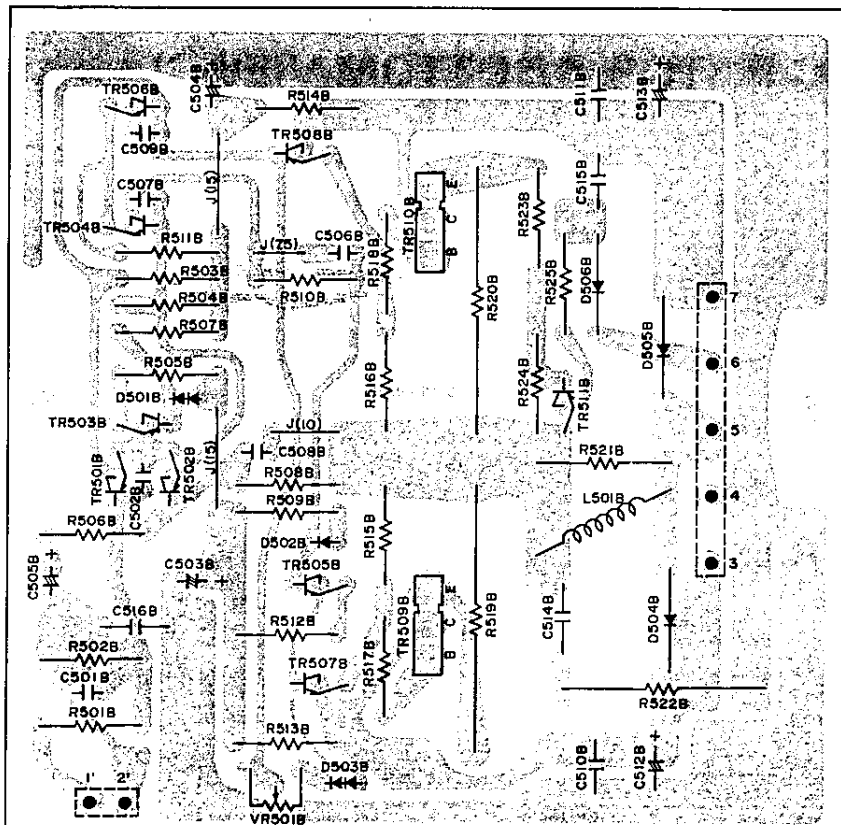


15) MAIN AMP P.C.B. (RIGHT) (TOP & BOTTOM VIEWS)

TOP VIEW

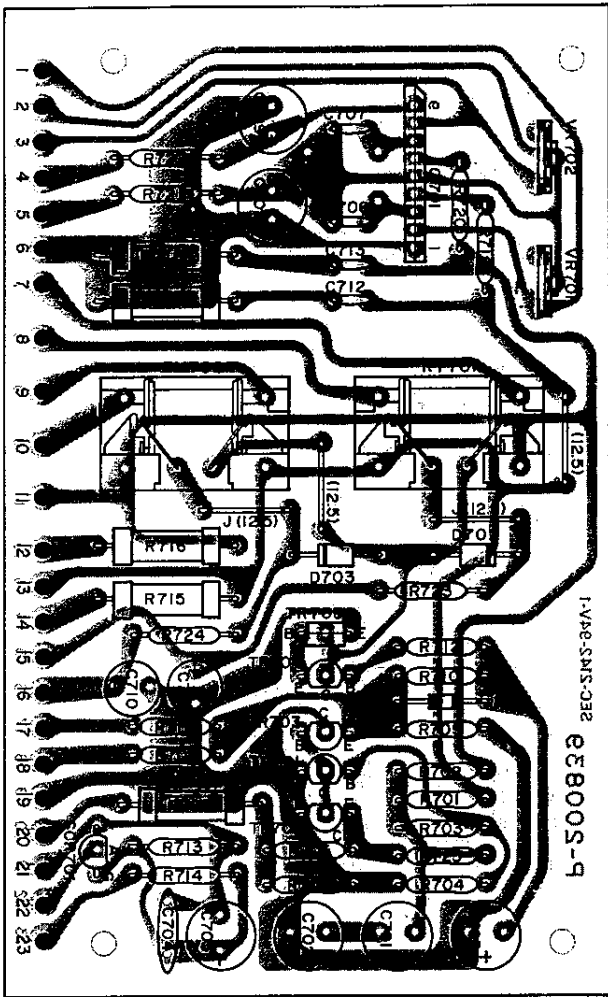


BOTTOM VIEW

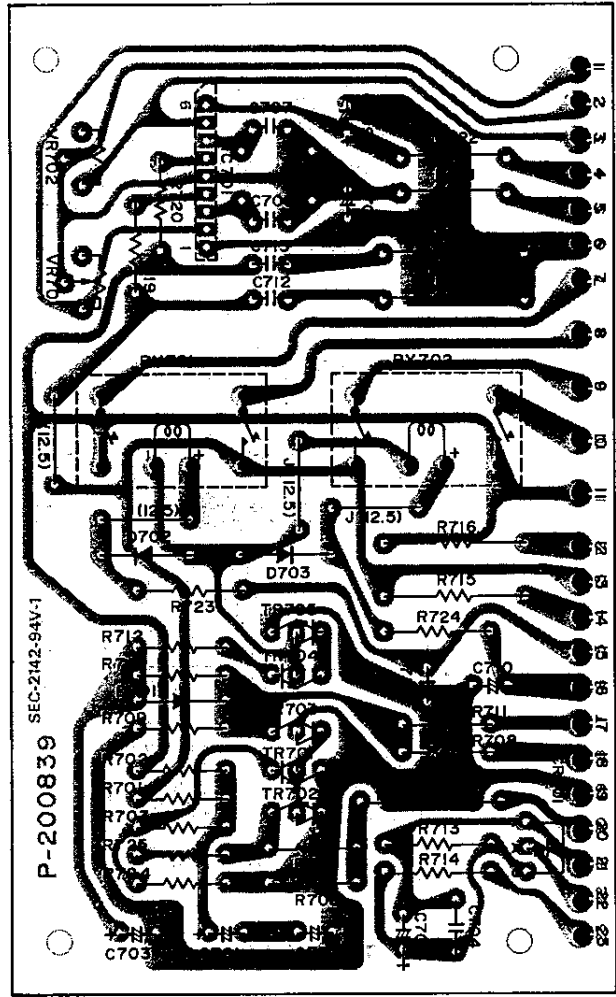


16) PROTECTOR P.C.B. (TOP & BOTTOM VIEWS)

TOP VIEW

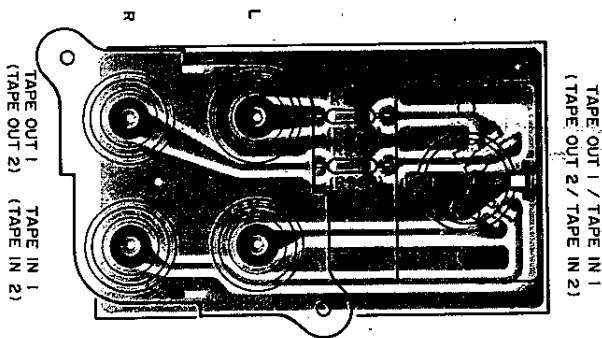


BOTTOM VIEW

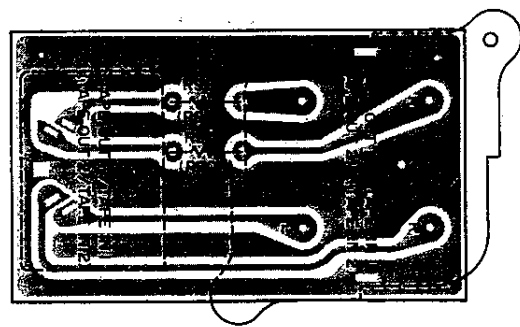


17) TAPE P.C.B. (TOP & BOTTOM VIEWS)

TOP VIEW

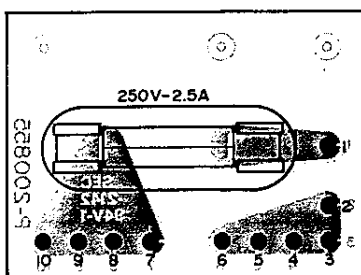


BOTTOM VIEW

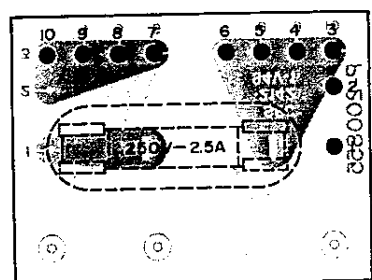


18) FUSE P.C.B. (TOP & BOTTOM VIEWS)

TOP VIEW

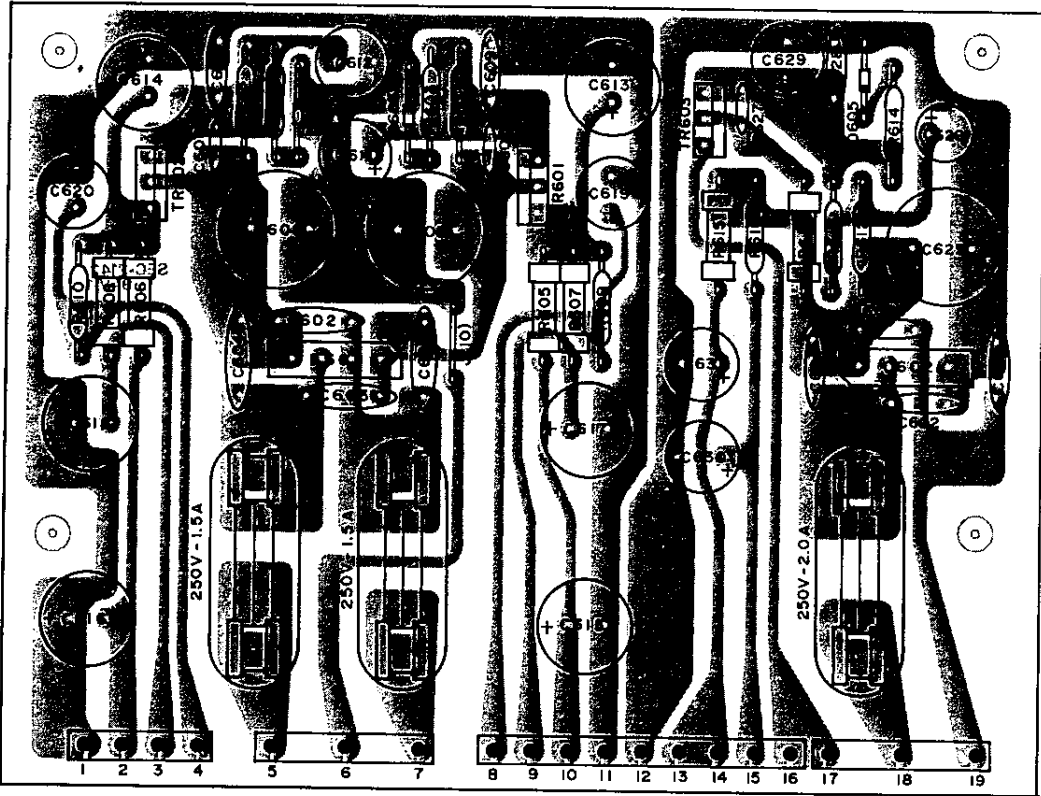


BOTTOM VIEW

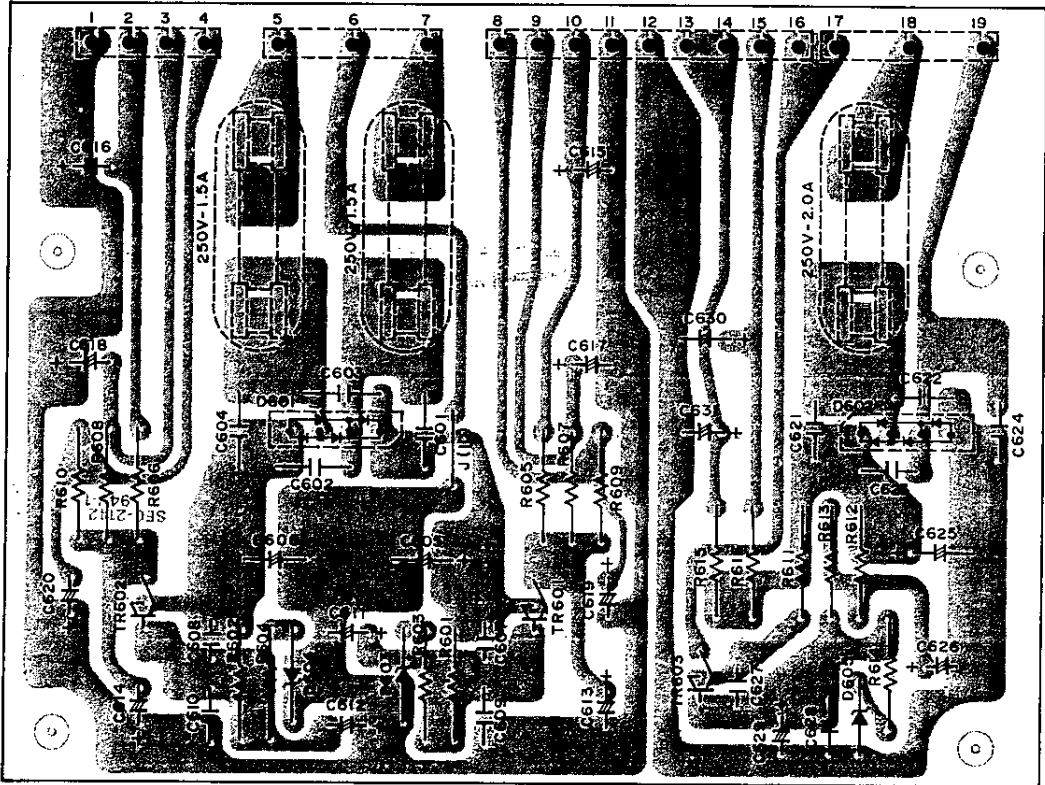


19) POWER SUPPLY P.C.B. (TOP & BOTTOM VIEWS)

TOP VIEW



BOTTOM VIEW



23) ELECTRICAL PARTS LIST

CAPACITORS						Ref. No.	Value (F)	Voltage (V)	Tolerance (%)	Material	R/S Part No.
C101	10p (NPO)	50	±0.5pF	Ceramic	CF-1141	C155	680p	50	±5	Polystyrene	
C102	47p	50	±5	Ceramic		C156	1500p	50	±5	Polystyrene	
C103	0.0047μ	50	±10	Ceramic		C157	0.22μ	25/35	±20	Tantalum	
C104	0.022μ	25	+80/-20	Ceramic		C158	0.47μ	25/35	±20	Tantalum	
C105	15p (NPO)	50	±5	Ceramic	CF-1188	C159	0.1μ	50	±10	Mylar	
C106	0.0047μ	50	±10	Ceramic		C160	10μ	16	+50/-10	Electrolytic	
C107	15p (NPO)	50	±5	Ceramic	CF-1188	C161	0.022μ	50	±10	Mylar	
C108	7p (NPO)	50	±0.5pF	Ceramic	CF-1115		(UL, C.S.A.)				
C109	7p (NPO)	50	±0.5pF	Ceramic	CF-1115	C161	0.015μ	50	±10	Mylar	
C110	100p	50	±5	Ceramic			(Australian, European)				
C111	0.022μ	25	±5	Ceramic		C162	0.022μ	50	±10	Mylar	
C112	0.022μ	25	±5	Ceramic			(UL, C.S.A.)				
C113	0.022μ	25	±5	Ceramic		C162	0.015	50	±10	Mylar	
C114	5p (NPO)	50	±0.25pF	Ceramic	CF-1099		(Australian, European)				
C115	15p (N330)	50	±5	Ceramic		C163	0.47μ	50	+75/-10	Electrolytic	
C116	0.47p	500	±10	G-Capacitor		C164	0.47μ	50	+75/-10	Electrolytic	
C117	10p (NPO)	50	±0.5pF	Ceramic	CF-1893	C165	3.3μ	50	+75/-10	Electrolytic	
C118	33p (NPO)	50	±5	Ceramic		C166	3.3μ	50	+75/-10	Electrolytic	
C119	0.022μ	25	+80/-20	Ceramic		C167	1μ	50	+75/-10	Electrolytic	
C120	10p (NPO)	50	±0.5pF	Ceramic	CF-1141	C168	1μ	50	+75/-10	Electrolytic	
C121	0.01μ	25	+80/-20	Ceramic		C169	100μ	16	+50/-10	Electrolytic	
C122	0.01μ	25	+80/-20	Ceramic		C170	47μ	10	+50/-10	Electrolytic	
C123	0.047μ	25	+80/-20	Ceramic		C171	470μ	16	+50/-10	Electrolytic	
C124	0.022μ	25	+80/-20	Ceramic		C172	100μ	16	+50/-10	Electrolytic	
C125	0.01μ	25	+80/-20	Ceramic							
C126	0.022μ	25	+80/-20	Ceramic		C201	340p	50	±5	Polystyrene	
C127	0.047μ	25	+80/-20	Ceramic		C202	12p (NPO)	50	±5	Ceramic	CF-1180
C128	0.01μ	25	+80/-20	Ceramic		C203	0.01μ	25	+80/-20	Ceramic	
C129	0.022μ	25	+80/-20	Ceramic		C204	0.01μ	25	+80/-20	Ceramic	
C130	0.047μ	25	+80/-20	Ceramic		C205	0.01μ	25	+80/-20	Ceramic	
C131	0.01μ	25	+80/-20	Ceramic		C206	0.01μ	25	+80/-20	Ceramic	
C132	1μ	50	+75/-10	Electrolytic		C207	0.01μ	25	+80/-20	Ceramic	
C133	0.022μ	25	+80/-20	Ceramic		C208	0.001μ	50	±10	Ceramic	
C134	0.047μ	25	+80/-20	Ceramic		C209	0.022μ	25	+80/-20	Ceramic	
C135	0.022μ	25	+80/-20	Ceramic		C210	100μ	16	+50/-10	Electrolytic	
C136	0.047μ	25	+80/-20	Ceramic		C211	0.01μ	25	+80/-20	Ceramic	
C137	0.047μ	25	+80/-20	Ceramic		C212	0.001μ	50	±10	Ceramic	
C138	0.047μ	25	+80/-20	Ceramic		C213	0.047μ	25	+80/-20	Ceramic	
C139	33p	50	±5	Ceramic		C214	4.7μ	25	+50/-10	Electrolytic	
C140	1μ	50	+75/-10	Electrolytic		C215	3.3μ	50	+75/-10	Electrolytic	
C141	0.047μ	25	+80/-20	Ceramic		C216	0.033μ	50	±10	Mylar	
C142	0.047μ	25	+80/-20	Ceramic		C217	0.15μ	50	±10	Mylar	
C143	0.047μ	25	+80/-20	Ceramic		C218	4.7μ	25	+50/-10	Electrolytic	
C144	0.0047μ	50	+80/-20	Ceramic		C219	0.022μ	25	+80/-20	Ceramic	
C145	1μ	50	+75/-10	Electrolytic		C220	0.47μ	50	+75/-10	Electrolytic	
C146	1μ	50	+75/-10	Electrolytic		C221	220p	50	±5	Ceramic	
C147	0.022μ	25	+80/-20	Ceramic		C222	0.47μ	50	+75/-10	Electrolytic	
C148	0.022μ	25	+80/-20	Ceramic		C223	0.022μ	25	+80/-20	Ceramic	
C149	4.7μ	25	+50/-10	Electrolytic		C224	0.022μ	25	+80/-20	Ceramic	
C150	220μ	16	+50/-10	Electrolytic		C225	100μ	16	+50/-10	Electrolytic	
C151	0.047μ	25	+80/-20	Ceramic							
C152	0.047μ	25	+80/-20	Ceramic		C301	2.2μ	35	±20	Tantalum	
C153	220μ	16	+50/-10	Electrolytic		C302	2.2μ	35	±20	Tantalum	
C154	0.047μ	50	±10	Mylar		C303	100p	50	±5	Ceramic	
						C304	100p	50	±5	Ceramic	

Ref. No.	Value (F)	Voltage (V)	Tolerance (%)	Material	R/S Part No.	Ref. No.	Value (F)	Voltage (V)	Tolerance (%)	Material	R/S Part No.
C305	47 μ	25	+50/-10	Electrolytic		C429	2.2 μ	50	+75/-10	Electrolytic	
C306	47 μ	25	+50/-10	Electrolytic		C430	2.2 μ	50	+75/-10	Electrolytic	
C307	47p	50	\pm 5	Ceramic		C431	100p	50	\pm 5	Ceramic	
C308	47p	50	\pm 5	Ceramic		C432	100p	50	\pm 5	Ceramic	
C309	100 μ	16	+50/-10	Electrolytic		C433	4.7 μ	25	+50/-10	Electrolytic	
C310	100 μ	16	+50/-10	Electrolytic		C434	4.7 μ	25	+50/-10	Electrolytic	
C311	100 μ	25	+50/-10	Electrolytic		C435	0.0033 μ	50	\pm 10	Mylar	
C312	100 μ	25	+50/-10	Electrolytic		C436	0.0033 μ	50	\pm 10	Mylar	
C313	0.15 μ	50	\pm 5	Mylar		C437	0.0027 μ	50	\pm 10	Mylar	
C314	0.15 μ	50	\pm 5	Mylar		C438	0.0027 μ	50	\pm 10	Mylar	
C315	0.082 μ	50	\pm 5	Mylar		C439	2.2 μ	25	+75/-10	Electrolytic	
C316	0.082 μ	50	\pm 5	Mylar			(non-polar)				
C317	0.68 μ	35	\pm 10	Electrolytic		C440	2.2 μ	25	+75/-10	Electrolytic	
C318	0.68 μ	50	\pm 10	Electrolytic			(non-polar)				
C319	0.04 μ	50	+80/-20	Ceramic		C441	0.47 μ	50	+75/-10	Electrolytic	
C320	0.04 μ	50	+80/-20	Ceramic		C442	0.47 μ	50	+75/-10	Electrolytic	
C321	100 μ	35	+50/-10	Electrolytic		C443	15p	50	\pm 5	Ceramic	
C322	100 μ	35	+50/-10	Electrolytic		C444	15p	50	\pm 5	Ceramic	
C323	0.0022 μ	50	\pm 5	Mylar		C445	100p	50	\pm 5	Ceramic	
C324	0.0022 μ	50	\pm 5	Mylar		C446	100p	50	\pm 5	Ceramic	
C325	0.0047 μ	50	\pm 5	Mylar		C447	470 μ	25	+50/-10	Electrolytic	
C326	0.0047 μ	50	\pm 5	Mylar		C448	470 μ	25	+50/-10	Electrolytic	
C327	0.0027 μ	50	\pm 5	Mylar		C449	2.2 μ	25	+75/-10	Electrolytic	
C328	0.0027 μ	50	\pm 5	Mylar			(non-polar)				
C329	0.1 μ	25	\pm 20	Aluminum		C450	2.2 μ	25	+75/-10	Electrolytic	
C330	33 μ	16	+50/-10	Electrolytic			(non-polar)				
C331	150p	50	\pm 5	Ceramic		C451	2.2 μ	50	+75/-10	Electrolytic	
C332	150p	50	\pm 5	Ceramic		C452	2.2 μ	50	+75/-10	Electrolytic	
C401	1 μ	50	+75/-10	Electrolytic		C453	220 μ	25	+50/-10	Electrolytic	
C402	1 μ	50	+75/-10	Electrolytic		C454	220 μ	25	+50/-10	Electrolytic	
C403	100p	50	\pm 5	Ceramic		C501AB	180p	50	\pm 5	Ceramic	
C404	100p	50	\pm 5	Ceramic		C502AB	33p	50	\pm 5	Ceramic	
C405	3.3 μ	25	+75/-10	Electrolytic		C503AB	47 μ	63	+50/-10	Electrolytic	
C406	3.3 μ	25	+75/-10	Electrolytic		C504AB	47 μ	63	+50/-10	Electrolytic	
C407	2.2 μ	50	+75/-10	Electrolytic		C505AB	47 μ	25	+50/-10	Electrolytic	
C408	2.2 μ	50	+75/-10	Electrolytic		C506AB	0.015 μ	50	\pm 10	Mylar	
C409	22p	50	\pm 5	Ceramic		C507AB	330p	50	\pm 5	Ceramic	
C410	22p	50	\pm 5	Ceramic		C508AB	Not Used				
C411	4.7 μ	25	+50/-10	Electrolytic		C509AB	36p	50	\pm 5	Ceramic	
C412	4.7 μ	25	+50/-10	Electrolytic		C510AB	0.047 μ	100	+80/-20	Ceramic	
C413	47p	50	\pm 5	Ceramic		C511AB	0.047 μ	100	+80/-20	Ceramic	
C414	47p	50	\pm 5	Ceramic		C512AB	100 μ	63	+50/-10	Electrolytic	
C415	6p	50	\pm 0.25p	Ceramic		C513AB	100 μ	63	+50/-10	Electrolytic	
C416	6p	50	\pm 0.25p	Ceramic		C514AB	0.1 μ	100	\pm 10	Mylar	
C417	4.7 μ	25	+50/-10	Electrolytic		C515AB	0.04 μ	50	+80/-20	Ceramic	
C418	4.7 μ	25	+50/-10	Electrolytic		C516AB	0.1 μ	50	\pm 10	Mylar	
C419	0.0033 μ	50	\pm 10	Mylar		C601	0.047 μ	100	+80/-20	Ceramic	
C420	0.0033 μ	50	\pm 10	Mylar		C602	0.047 μ	100	+80/-20	Ceramic	
C421	0.018 μ	50	\pm 10	Mylar		C603	0.047 μ	100	+80/-20	Ceramic	
C422	0.018 μ	50	\pm 10	Mylar		C604	0.047 μ	100	+80/-20	Ceramic	
C423	100 μ	25	+50/-10	Electrolytic		C605	470 μ	50	+50/-10	Electrolytic	
C424	100 μ	25	+50/-10	Electrolytic		C606	470 μ	50	+50/-10	Electrolytic	
C425	0.015 μ	50	\pm 10	Mylar		C607	100p	50	\pm 5	Ceramic	
C426	0.015 μ	50	\pm 10	Mylar		C608	100p	50	\pm 5	Ceramic	
C427	0.1 μ	50	\pm 10	Mylar		C609	0.04 μ	50	+80/-20	Ceramic	
C428	0.1 μ	50	\pm 10	Mylar		C610	0.04 μ	50	+80/-20	Ceramic	
						C611	100 μ	35	+50/-10	Electrolytic	

Ref. No.	Value (F)	Voltage (V)	Tolerance (%)	Material	R/S Part No.
C612	100 μ	35	+50/-10	Electrolytic	
C613	220 μ	35	+50/-10	Electrolytic	
C614	220 μ	35	+50/-10	Electrolytic	
C615	220 μ	35	+50/-10	Electrolytic	
C616	220 μ	35	+50/-10	Electrolytic	
C617	220 μ	35	+50/-10	Electrolytic	
C618	220 μ	35	+50/-10	Electrolytic	
C619	100 μ	25	+50/-10	Electrolytic	
C620	100 μ	25	+50/-10	Electrolytic	
C621	0.04 μ	50	+80/-20	Ceramic	
C622	0.04 μ	50	+80/-20	Ceramic	
C623	0.04 μ	50	+80/-20	Ceramic	
C624	0.04 μ	50	+80/-20	Ceramic	
C625	1000 μ	25	+50/-10	Electrolytic	
C626	47 μ	25	+50/-10	Electrolytic	
C627	100p	50	\pm 5	Ceramic	
C628	0.04 μ	50	+80/-20	Ceramic	
C629	220 μ	25	+50/-10	Electrolytic	
C630	100 μ	25	+50/-10	Electrolytic	
C701	220 μ	25	+50/-10	Electrolytic	
C702	220 μ	25	+50/-10	Electrolytic	
C703	220 μ	16	+50/-10	Electrolytic	
C704	0.04 μ	50	+80/-20	Ceramic	
C705	220 μ	25	+50/-10	Electrolytic	
C706	0.0015 μ	50	\pm 10	Mylar	
C707	0.0015 μ	50	\pm 10	Mylar	
C708	47 μ	25	+50/-10	Electrolytic	
C709	47 μ	25	+50/-10	Electrolytic	
C710	0.47 μ	50	+75/-10	Electrolytic	
C711	0.47 μ	50	+75/-10	Electrolytic	
C712	0.001 μ	100	\pm 10	Mylar	
C713	0.001 μ	100	\pm 10	Mylar	
C801	0.22 μ	35	\pm 10	Tantalum	
C802	0.22 μ	35	\pm 10	Tantalum	
C803	330p	50	\pm 5	Polystyrene	
C804	330p	50	\pm 5	Polystyrene	
C805	0.0068 μ	50	\pm 10	Mylar	
C806	0.0068 μ	50	\pm 10	Mylar	
C901	0.01 μ	50	+80/-20	Ceramic	
C902	0.01 μ	50	+80/-20	Ceramic	
C903	0.01 μ	50	+80/-20	Ceramic	
C904	0.01 μ	50	+80/-20	Ceramic	
C905	0.01 μ	50	+80/-20	Ceramic	
C906	0.01 μ	50	+80/-20	Ceramic	
C907	0.01 μ	50	+80/-20	Ceramic	
C908	15000 μ	63	+50/-10	Electrolytic	CF-7303
C909	15000 μ	63	+50/-10	Electrolytic	CF-7303
C910	0.047 μ	150	+80/-20	Ceramic	
C911	0.047 μ	150	+80/-20	Ceramic	
C912	0.047 μ	150	+80/-20	Ceramic	
C913	0.047 μ	150	+80/-20	Ceramic	
C914	0.01 μ	125	+80/-20	Ceramic	
C914	0.01 μ	125	+80/-20	Ceramic	(UK535 type or LB type)(UL) (MY type) (C.S.A.)
C914	0.01 μ	250	+80/-20	Ceramic	(RME271M type) (European, Australian)
C915	0.01 μ	250	+80/-20	Ceramic	(RME271M Type) (European, Australian)

CERAMIC FILTERS			
Ref. No.	Description	R/S Part No.	Mfr's Part No.
CF101	FM Ceramic Filter SFE 10.7 MA-8-M	CA-7536	P-140030
CF102	FM Ceramic Filter SFE 10.7 MA-8-M	CA-7536	P-140030
CF103	FM Ceramic Filter SFE 10.7 MA-8-M	CA-7536	P-140030

COILS & TRANSFORMERS			
Ref. No.	Description	R/S Part No.	Mfr's Part No.
L101	FM Antenna Coil	CA-0608	P-110109
L102	FM RF 1 Coil	CA-5103	P-110110
L103	FM RF 2 Coil	CA-5104	P-110111
L104	FM OSC Coil	CA-5028	P-120086
L105	Micro Inductor 2.2 μ H \pm 10%	CA-5072	P-350034
L106	Micro Inductor 18 μ H \pm 10%	C-0709	P-360022
L107	Micro Inductor 2.2 μ H \pm 10%	CA-7873	P-360021
L201	Micro Inductor 2.2 μ H \pm 10%	CA-5072	P-360034
L202	Micro Inductor 2.2 μ H \pm 10%	CA-7873	P-360021
L203	Micro Inductor 2.2 μ H \pm 10%	CA-7873	P-360021
L501A	Choke Coil 2 μ H	CB-2298	P-370009
L501B	Choke Coil 2 μ H	CA-7987	P-370032
L901	AM Antenna Coil 260 μ H	CA-5108	P-110108
L902	Balun Coil 35 Ω : 300 Ω	CA-5074	P-110102
T101	FM IFT 7F-007	CA-7970	P-140007
T102	FM IFT 3F-033	VA-7951	P-140033
T201	AM RF Coil OR-092	CA-5105	P-340092
T202	AM OSC Coil OC-091	CA-5106	P-120091
T203	AM IFT with Ceramic Filter OA-023	C-0575	P-130023
T204	AM IFT OA-048	CA-7882	P-130048
T901	Power Transformer (UL)		P-100748
T901	Power Transformer (C.S.A.)		P-100826
T901	Power Transformer (European, Australian)		P-100749

DIODES			
Ref. No.	Description	R/S Part No.	Manufacturer
D101	ITT-410	DX-0307	ITT
D102	ITT-73N	DX-1008	ITT
D103	ITT-73N	DX-1008	ITT
D104	ITT-73N	DX-1008	ITT
D105	ITT-73N	DX-1008	ITT
D106	VD-1221	DX-0517	NEC
D107	VD-1221	DX-0517	NEC
D108	VD-1221	DX-0517	NEC
D109	ITT-73N	DX-1008	ITT

Ref. No.	Description	R/S Part No.	Manufacturer	Ref. No.	Description	R/S Part No.	Mfr's Part No.		
D201	ITT-73N	DX-1008	ITT	F901	Fuse 7A/125V (UL, C.S.A.) or Fuse 7A/125V (UL, C.S.A.)	HF-1124	P-250101		
D301	SR1K-2 or 10E-1	DX-0475	UNIZON INTER-RECTIFIER	F901	Fuse 3.15A/250V (European, Australian)		P-250119 P-250094		
D302	ITT-73N	DX-1008	ITT	F902	Fuse 2.5A/250V	HF-0021	P-250008		
D303	ITT-73N	DX-1008	ITT	INTEGRATED CIRCUITS (IC'S)					
D304	ITT-73N	DX-1008	ITT	Ref. No.	Description	R/S Part No.	Manufacturer		
D501AB	VD-1221	DX-0517	NEC	IC101	LA-1231 NS	MX-3963	SANYO		
D502AB	VD-1121	DX-0513	NEC	IC102	LA-3350 SS	MX-3768	SANYO		
D503AB	MV-11Y	DX-1226	OHIZUMI	IC103	NJM-4558 DX	MX-3966	JRC		
D504AB	SR1K-2 or 10E-1	DX-0475	UNIZON INTER-RECTIFIER	IC201	HA-1197	MX-3467	HITACHI		
D505AB	SR1K-2 or 10E-1	DX-0475	UNIZON INTER-RECTIFIER	IC701	TA-7318P (2)	MX-4448	TOSHIBA		
D506AB	1N-60P	DX-0162	HITACHI	LAMPS					
D601	SVB 10-200	DX-1115	UNIZON	Ref. No.	Description	R/S Part No.	Mfr's Part No.		
D602	SVB 10-200	DX-1115	UNIZON	DL1	Dial Lamp 8V 300 mA		P-240141		
D603	RD-33E-B4	DX-1409	NEC	DL2	Dial Lamp 8V 300 mA		P-240141		
D604	RD-33E-B4	DX-1409	NEC	ML1	Meter Lamp 8V 300mA		P-240128 or P-240135		
D605	RD-13E-B3	DX-1408	NEC	ML2	Signal Lamp 8V 300mA		P-240129 or P-240136		
D701	ITT-73N	DX-1008	ITT	ML3	Watt Lamp (R) 8V 300mA		P-240130 or P-240137		
D702	SR1K-2 or 10E-1	DX-0475	UNIZON INTER-RECTIFIER	ML4	Watt Lamp (L) 8V 300mA		P-240131 or P-240138		
D703	SR1K-2 or 10E-1	DX-0475	UNIZON INTER-RECTIFIER	FILTERS					
D801	SLP 151B (LED)	L-1185	SANYO	Ref. No.	Description	R/S Part No.	Mfr's Part No.		
D802	SLP 151B (LED)	L-1185	SANYO	LPF101	Low Pass Filter (19 kHz/38 kHz)	CB-0159	P-510012		
D803	SLP 151B (LED)	L-1185	SANYO	LPF102	Low Pass Filter (19 kHz/38 kHz)	CB-0159	P-510012		
D804	SLP 151B (LED)	L-1185	SANYO	FUSES					
D805	SLP 151B (LED)	L-1185	SANYO	Ref. No.	Description	R/S Part No.	Mfr's Part No.		
D901	S15VB-20		SHINDENGEN	F601	Fuse 1.5A/250V	HF-0004	P-250007		
D902	SLP 151B (LED)	L-1185	SANYO	F602	Fuse 1.5A/250V	HF-0004	P-250007		
				F603	Fuse 2A/250V	HF-0043	P-250079		
				RESISTORS					
				Ref. No.	Value (ohm)	Wattage (W)	Tolerance (%)	Material	R/S Part No.
				R101	100K	¼	±5	Carbon	NEE-0371
				R102	82K	¼	±5	Carbon	NEE-0360
				R103	100K	¼	±5	Carbon	NEE-0371
				R104	22	¼	±5	Carbon	NEE-0078
				R105	47	¼	±5	Carbon	NEE-0099
				R106	22K	¼	±5	Carbon	NEE-0311
				R107	4.7K	¼	±5	Carbon	NEE-0247
				C108	1K	¼	±5	Carbon	NEE-0196
				C109	100	¼	±5	Carbon	NEE-0132
				C110	150K	¼	±5	Carbon	NEE-0384
				R111	10K	¼	±5	Carbon	NEE-0281
				R112	12K	¼	±5	Carbon	NEE-0288

Ref. No.	Value (ohm)	Wattage (W)	Tolerance (%)	Material	R/S Part No.	Ref. No.	Value (ohm)	Wattage (W)	Tolerance (%)	Material	R/S Part No.
R113	100	¼	±5	Carbon	NEE-0132	R171	100K	¼	±5	Carbon	NEE-0371
R114	2.2K	¼	±5	Carbon	NEE-0216	R172	100K	¼	±5	Carbon	NEE-0371
R115	470K	¼	±5	Carbon	NEE-0423	R173	100K	¼	±5	Carbon	NEE-0371
R116	100	¼	±5	Carbon	NEE-0132	R174	100K	¼	±5	Carbon	NEE-0371
R117	330	¼	±5	Carbon	NEE-0159	R175	15K	¼	±5	Carbon	NEE-0297
R118	10K	¼	±5	Carbon	NEE-0281	R176	15K	¼	±5	Carbon	NEE-0297
R119	3.9K	¼	±5	Carbon	NEE-0237	R177	2.2K	¼	±5	Carbon	NEE-0216
R120	1K	¼	±5	Carbon	NEE-0196	R178	2.2K	¼	±5	Carbon	NEE-0216
R221	180	¼	±5	Carbon	NEE-0144	R179	2.2K	¼	±5	Carbon	NEE-0216
R122	180	¼	±5	Carbon	NEE-0144	R180	2.2K	¼	±5	Carbon	NEE-0216
R123	330	¼	±5	Carbon	NEE-0159	R181	10K	¼	±5	Carbon	NEE-0281
R124	2.2K	¼	±5	Carbon	NEE-0216	R182	10K	¼	±5	Carbon	NEE-0281
R125	10K	¼	±5	Carbon	NEE-0281	R183	100	¼	±5	Carbon	NEE-0132
R126	1K	¼	±5	Carbon	NEE-0196	R184	270	¼	±5	Carbon	NEE-0155
R127	180	¼	±5	Carbon	NEE-0144	R185	220	¼	±5	Carbon	NEE-0149
R128	180	¼	±5	Carbon	NEE-0144	R186	100K	¼	±5	Carbon	NEE-0371
R129	330	¼	±5	Carbon	NEE-0159	R201	1.8K	¼	±5	Carbon	NEE-0210
R130	2.2K	¼	±5	Carbon	NEE-0216	R202	5.6K	¼	±5	Carbon	NEE-0257
R131	10K	¼	±5	Carbon	NEE-0281	R203	10K	¼	±5	Carbon	NEE-0281
R132	1K	¼	±5	Carbon	NEE-0196	R204	330	¼	±5	Carbon	NEE-0159
R133	180	¼	±5	Carbon	NEE-0144	R205	10K	¼	±5	Carbon	NEE-0281
R134	180	¼	±5	Carbon	NEE-0144	R206	100	¼	±5	Carbon	NEE-0132
R135	100	¼	±5	Carbon	NEE-0132	R207	1K	¼	±5	Carbon	NEE-0196
R136	100	¼	±5	Carbon	NEE-0132	R208	10K	¼	±5	Carbon	NEE-0281
R137	100	¼	±5	Carbon	NEE-0132	R209	4.7K	¼	±5	Carbon	NEE-0247
R138	47K	¼	±5	Carbon	NEE-0340	R210	1.5M	¼	±5	Carbon	NEE-0450
R139	10K	¼	±5	Carbon	NEE-0281	R211	5.6K	¼	±5	Carbon	NEE-0257
R140	4.7K	¼	±5	Carbon	NEE-0247	R212	820	¼	±5	Carbon	NEE-0187
R141	1.5K	¼	±5	Carbon	NEE-0206	R213	22	¼	±5	Carbon	NEE-0078
R142	10K	¼	±5	Carbon	NEE-0281	R214	150	¼	±5	Carbon	NEE-0142
R143	39K	¼	±5	Carbon	NEE-0330	R215	39K	¼	±5	Carbon	NEE-0330
R144	100K	¼	±5	Carbon	NEE-0371	R301	56K	¼	±5	Carbon	NEE-0345
R145	100K	¼	±5	Carbon	NEE-0371	R302	56K	¼	±5	Carbon	NEE-0345
R146	330	¼	±5	Carbon	NEE-0159	R303	470	¼	±5	Carbon	NEE-0169
R147	56K	¼	±5	Carbon	NEE-0345	R304	470	¼	±5	Carbon	NEE-0169
R148	47K	¼	±5	Carbon	NEE-0340	R305	390K	¼	±5	Carbon	NEE-0414
R149	5.6K	¼	±5	Carbon	NEE-0257	R306	390K	¼	±5	Carbon	NEE-0414
R150	1K	¼	±5	Carbon	NEE-0196	R307	22K	¼	±5	Carbon	NEE-0311
R151	8.2K	¼	±5	Carbon	NEE-0271	R308	22K	¼	±5	Carbon	NEE-0311
R152	47K	¼	±5	Carbon	NEE-0340	R309	100K	¼	±5	Carbon	NEE-0371
R153	2.2K	¼	±5	Carbon	NEE-0216	R310	100K	¼	±5	Carbon	NEE-0371
R154	10K	¼	±5	Carbon	NEE-0281	R311	560	¼	±5	Carbon	NEE-0176
R155	4.7K	¼	±5	Carbon	NEE-0247	R312	560	¼	±5	Carbon	NEE-0176
R156	10K	¼	±5	Carbon	NEE-0281	R313	33K	¼	±5	Carbon	NEE-0324
R157	22	¼	±5	Carbon	NEE-0078	R314	33K	¼	±5	Carbon	NEE-0324
R158	10K	¼	±5	Carbon	NEE-0281	R315	390K	¼	±5	Carbon	NEE-0414
R159	3.3K	¼	±5	Carbon	NEE-0230	R316	390K	¼	±5	Carbon	NEE-0414
R160	1K	¼	±5	Carbon	NEE-0196	R317	560	¼	±5	Carbon	NEE-0176
R161	1.8K	¼	±5	Carbon	NEE-0210	R318	560	¼	±5	Carbon	NEE-0176
R162	39K	¼	±5	Carbon	NEE-0330	R319	270	¼	±5	Carbon	NEE-0155
R163	47K	¼	±5	Carbon	NEE-0340	R320	270	¼	±5	Carbon	NEE-0155
R164	1K	¼	±5	Carbon	NEE-0196	R321	10K	¼	±5	Carbon	NEE-0281
R165	8.2K	¼	±5	Carbon	NEE-0271	R322	10K	¼	±5	Carbon	NEE-0281
R166	10K	¼	±5	Carbon	NEE-0281	R323	1K	¼	±5	Carbon	NEE-0196
R167	3.3K	¼	±5	Carbon	NEE-0230	R324	1K	¼	±5	Carbon	NEE-0196
R168	3.3K	¼	±5	Carbon	NEE-0230						
R169	1K	¼	±5	Carbon	NEE-0196						
R170	1K	¼	±5	Carbon	NEE-0196						

Ref. No.	Value (ohm)	Wattage (W)	Tolerance (%)	Material	R/S Part No.	Ref. No.	Value (ohm)	Wattage (W)	Tolerance (%)	Material	R/S Part No.
R325	56K	¼	±5	Carbon	NEE-0345	R434	1.2K	¼	±5	Carbon	NEE-0199
R326	56K	¼	±5	Carbon	NEE-0345	R435	22K	¼	±5	Carbon	NEE-0311
R327	220K	¼	±5	Carbon	NEE-0396	R436	22K	¼	±5	Carbon	NEE-0311
R328	220K	¼	±5	Carbon	NEE-0396	R437	39K	¼	±5	Carbon	NEE-0330
R329	4.7K	¼	±5	Carbon	NEE-0247	R438	39K	¼	±5	Carbon	NEE-0330
R330	4.7K	¼	±5	Carbon	NEE-0247	R439	2.7K	¼	±5	Carbon	NEE-0224
R331	100	¼	±5	Carbon	NEE-0132	R440	2.7K	¼	±5	Carbon	NEE-0224
R332	100	¼	±5	Carbon	NEE-0132	R441	39K	¼	±5	Carbon	NEE-0330
R333	47K	¼	±5	Carbon	NEE-0340	R442	39K	¼	±5	Carbon	NEE-0330
R334	47K	¼	±5	Carbon	NEE-0340	R443	5.6K	¼	±5	Carbon	NEE-0257
R335	15K	¼	±5	Carbon	NEE-0297	R444	5.6K	¼	±5	Carbon	NEE-0257
R336	15K	¼	±5	Carbon	NEE-0297	R445	220K	¼	±5	Carbon	NEE-0396
R337	100	¼	±5	Carbon	NEE-0132	R446	220K	¼	±5	Carbon	NEE-0396
R338	100	¼	±5	Carbon	NEE-0132	R447	4.7K	¼	±5	Carbon	NEE-0247
R339	100K	¼	±5	Carbon	NEE-0371	R448	4.7K	¼	±5	Carbon	NEE-0247
R340	39K	¼	±5	Carbon	NEE-0330	R449	15K	¼	±5	Carbon	NEE-0297
R341	390K	¼	±5	Carbon	NEE-0414	R450	15K	¼	±5	Carbon	NEE-0297
R342	39K	¼	±5	Carbon	NEE-0330	R451	100K	¼	±5	Carbon	NEE-0371
R343	100	¼	±5	Carbon	NEE-0132	R452	100K	¼	±5	Carbon	NEE-0371
R344	100	¼	±5	Carbon	NEE-0132	R453	22K	¼	±5	Carbon	NEE-0311
R345	4.7K	¼	±5	Carbon	NEE-0247	R454	22K	¼	±5	Carbon	NEE-0311
R346	4.7K	¼	±5	Carbon	NEE-0247	R455	680K	¼	±5	Carbon	NEE-0433
R347	4.7K	¼	±5	Carbon	NEE-0247	R456	680K	¼	±5	Carbon	NEE-0433
R348	4.7K	¼	±5	Carbon	NEE-0247	R457	15K	¼	±5	Carbon	NEE-0297
						R458	15K	¼	±5	Carbon	NEE-0297
R401	220K	¼	±5	Carbon	NEE-0396	R459	100K	¼	±5	Carbon	NEE-0371
R402	220K	¼	±5	Carbon	NEE-0396	R460	100K	¼	±5	Carbon	NEE-0371
R403	100K	¼	±5	Carbon	NEE-0371	R461	6.8K	¼	±5	Carbon	NEE-0262
R404	100K	¼	±5	Carbon	NEE-0371	R462	6.8K	¼	±5	Carbon	NEE-0262
R405	4.7K	¼	±5	Carbon	NEE-0247	R463	4.7M	¼	±5	Carbon	
R406	4.7K	¼	±5	Carbon	NEE-0247	R464	4.7M	¼	±5	Carbon	
R407	1K	¼	±5	Carbon	NEE-0196	R465	1K	¼	±5	Carbon	NEE-0196
R408	1K	¼	±5	Carbon	NEE-0196	R466	1K	¼	±5	Carbon	NEE-0196
R409	2.2K	¼	±5	Carbon	NEE-0216	R467	4.7K	¼	±5	Carbon	NEE-0247
R410	2.2K	¼	±5	Carbon	NEE-0216	R468	4.7K	¼	±5	Carbon	NEE-0247
R411	56K	¼	±5	Carbon	NEE-0345	R469	470K	¼	±5	Carbon	NEE-0423
R412	56K	¼	±5	Carbon	NEE-0345	R470	470K	¼	±5	Carbon	NEE-0423
R413	100K	¼	±5	Carbon	NEE-0371	R471	150	½	±5	Carbon	NEF-0142
R414	100K	¼	±5	Carbon	NEE-0371	R472	150	½	±5	Carbon	NEF-0142
R415	100K	¼	±5	Carbon	NEE-0371	R473	470	¼	±5	Carbon	NEE-0169
R416	100K	¼	±5	Carbon	NEE-0371	R474	470	¼	±5	Carbon	NEE-0169
R417	100K	¼	±5	Carbon	NEE-0371	R501AB	2.2K	½	±5	Carbon	NEF-0216
R418	100K	¼	±5	Carbon	NEE-0371	R502AB	47K	½	±5	Carbon	NEF-0340
R419	1M	¼	±5	Carbon	NEE-0445	R503AB	2.7K	½	±5	Carbon	NEF-0224
R420	1M	¼	±5	Carbon	NEE-0445	R504AB	2.7K	½	±5	Carbon	NEF-0224
R421	10K	¼	±5	Carbon	NEE-0281	R505AB	330	½	±5	Carbon	NEF-0159
R422	10K	¼	±5	Carbon	NEE-0281	R506AB	1.8K	½	±5	Carbon	NEF-0210
R423	1.8K	¼	±5	Carbon	NEE-0210	R507AB	56K	½	±5	Carbon	NEF-0345
R424	1.8K	¼	±5	Carbon	NEE-0210	R508AB	47K	½	±5	Carbon	NEF-0340
R425	1K	¼	±5	Carbon	NEE-0196	R509AB	68	½	±5	Carbon	NEF-0111
R426	1K	¼	±5	Carbon	NEE-0196	R510AB	6.8K	1	±5	Metal Oxide	NEG-0262
R427	4.7K	¼	±5	Carbon	NEE-0247	R511AB	100	½	±5	Carbon	NEF-0132
R428	4.7K	¼	±5	Carbon	NEE-0247						
R429	330K	¼	±5	Carbon	NEE-0410						
R430	330K	¼	±5	Carbon	NEE-0410	R511AB	100	1	±5	Metal Oxide	NEG-0132
R431	680	¼	±5	Carbon	NEE-0183						
R432	680	¼	±5	Carbon	NEE-0183						
R433	1.2K	¼	±5	Carbon	NEE-0199	R512AB	68	½	±5	Carbon	NEF-0111
						R513AB	100	1	±5	Metal Oxide	NEG-0132
						R514AB	100	1	±5	Metal Oxide	NEG-0132

Ref. No.	Value (ohm)	Wattage (W)	Tolerance (%)	Material	R/S Part No.	Ref. No.	Value (ohm)	Wattage (W)	Tolerance (%)	Material	R/S Part No.
R515AB	100	1/2	±5	Carbon	NEF-0132	R718	4.7	2	±5	Metal Oxide	NEH-0047
R515AB	100	1	±5	Metal Oxide	NEG-0132	R719	27K	1/4	±5	Carbon	NEE-0316
R516AB	100	1/2	±5	Carbon	NEG-0132	R720	27K	1/4	±5	Carbon	NEE-0316
R516AB	100	1	±5	Metal Oxide	NEF-0132	R721	820	1/2	±5	Carbon	NEF-0187
R517AB	4.7	1/2	±5	Carbon	NEF-0047	R722	820	1/2	±5	Carbon	NEF-0187
R517AB	4.7	1	±5	Metal Oxide	NEG-0047	R723	120	1/2	±5	Carbon	NEF-0136
R518AB	4.7	1/2	±5	Carbon	NEF-0047	R724	120	1/2	±5	Carbon	NEF-0136
R518AB	4.7	1	±5	Metal Oxide	NEG-0047	R725	6.8K	1/4	±5	Carbon	NEE-0262
R519AB	0.5	7	±5	Cement		R801	3.9K	1/4	±5	Carbon	NEE-0237
R520AB	0.5	7	±5	Cement		R802	3.9K	1/4	±5	Carbon	NEE-0237
R521AB	4.7	2	±5	Metal Oxide	NEH-0047	R803	1.8K	1/4	±5	Carbon	NEE-0210
R522AB	10	3	±5	Metal Oxide	NEJ-0063	R901	220K	1/4	±5	Carbon	NEE-0396
R523AB	8.2K	1/2	±5	Carbon	NEF-0271	R902	220K	1/4	±5	Carbon	NEE-0396
R524AB	1K	1/2	±5	Carbon	NEF-0196	R903	220K	1/4	±5	Carbon	NEE-0396
R525AB	1K	1/2	±5	Carbon	NEF-0196	R904	220K	1/4	±5	Carbon	NEE-0396
R601	1.5K	1/2	±5	Carbon	NEF-0206	R905	2.2M	1/2	±5	Carbon	NEF-0454
R602	1.5K	1/2	±5	Carbon	NEF-0206	RELAYS					
R603	100	1/2	±5	Carbon	NEF-0132						
R604	100	1/2	±5	Carbon	NEF-0132	Ref. No.	Description			R/S Part No.	Mfr's Part No.
R605	120	1	±5	Metal Oxide	NEG-0136	RY301	Reed Relay L-23 (M)			R-8116	P-290022
R606	120	1	±5	Metal Oxide	NEG-0136	RY701	Relay G2Z 12V			R-8115	P-290035
R607	150	1	±5	Metal Oxide	NEG-0142	RY702	Relay G2Z 12V			R-8115	P-290035
R608	150	1	±5	Metal Oxide	NEG-0142	SILICON CONTROLLED RECTIFIER					
R609	680	1/2	±5	Carbon	NEF-0183						
R610	680	1/2	±5	Carbon	NEF-0183	Ref. No.	Description	R/S Part No.	Manufacturer		
R611	22	1	±5	Metal Oxide	NEG-0078	SCR701	03P-1M	DX-1407	NEC		
R612	820	1/2	±5	Carbon	NEF-0187	SWITCHES					
R613	820	1/2	±5	Carbon	NEF-0187						
R614	100	1/2	±5	Carbon	NEF-0132	Ref. No.	Description			R/S Part No.	Mfr's Part No.
R615	18	1	±5	Metal Oxide		Ss-1-Ss8	SELECTOR Switch			S-1424	P-180462
R616	470	1/2	±5	Carbon	NEF-0169		TAPE MONITOR Switch			S-1423	P-180461
R701	18K	1/4	±5	Carbon	NEE-0303		TAPE DUBBING Switch			S-1423	P-180461
R702	18K	1/4	±5	Carbon	NEE-0303		Push Switch (HIGH FILTER/ TONE DEFEAT/MONO/ LOUDNESS)			S-7498	P-180463
R703	3.3K	1/4	±5	Carbon	NEE-0230		Push Switch				P-180457
R704	6.8K	1/4	±5	Carbon	NEE-0262		(FM MUTE/HI-MPX FILTER)				P-180457
R705	10K	1/4	±5	Carbon	NEE-0281	Ps1	Push Switch (SPEAKERS A/B)				P-180464
R706	330	1/4	±5	Carbon	NEE-0159	Ps2	POWER Switch (UL, C.S.A.) with Push Switch				P-180464
R707	2.2K	2	±5	Metal Oxide	NEH-0216	Ps1-Ps3	Push Switch (UL, C.S.A.) with Power Switch				P-180467
R708	1	1/4	±5	Carbon	NEE-0010		POWER Switch (European, Australian)				P-180439
R709	1K	1/4	±5	Carbon	NEE-0196						
R710	8.2K	1/4	±5	Carbon	NEE-0271						
R711	10K	1/4	±5	Carbon	NEE-0281						
R712	27K	1/4	±5	Carbon	NEE-0316						
R713	1K	1/2	±5	Carbon	NEF-0196						
R714	820	1/2	±5	Carbon	NEF-0187						
R715	560	2	±5	Metal Oxide	NEH-0176						
R716	560	2	±5	Metal Oxide	NEH-0176						
R717	4.7	2	±5	Metal Oxide	NEH-0047						

TRANSISTORS			THERMAL PROTECTORS			
Ref. No.	Type No.	Manufacturer	Ref. No.	Description	R/S Part No.	Mfr's Part No.
TR101	3SK45B	HITACHI		THERMAL PROTECTOR (95° C) (UL)		P-290033
TR102	2SC1674 (L, K) or 2SC2786(L)	NEC		THERMAL PROTECTOR (95° C)		P-290018
TR103	2SC1674 (L, K) or 2SC2786(L)	NEC		(C.S.A., European, Australian)		P-290019
TR104	2SC1675 (L, K) or 2SC2787 (L)	NEC		THERMAL PROTECTOR(90° C)(C.S.A.)		
TR105	2SC1675 (L, K) or 2SC2787 (L)	NEC				
TR106	2SC1675 (L, K) or 2SC2787 (L)	NEC				
TR107	2SC1675 (L, K) or 2SC2787 (L)	NEC				
TR108	2SC945A (P)	NEC				
TR109	2SC945A (P)	NEC				
TR110	2SA733A (P)	NEC				
TR201	2SC945A (P)	NEC				
TR301	2SC1222 (1) (E, U)	NEC				
TR302	2SC1222 (1) (E, U)	NEC				
TR303	2SC1222 (1) (E, U)	NEC				
TR304	2SC1222 (1) (E, U)	NEC				
TR305	2SA750 (1) (E, U)	NEC				
TR306	2SA750 (1) (E, U)	NEC				
TR307	2SC1222 (1) (E, U)	NEC				
TR308	2SC1222 (1) (E, U)	NEC				
TR309	2SC945A (P)	NEC				
TR310	2SC945A (P)	NEC				
TR311	2SC945A (P)	NEC				
TR312	2SC945A (P)	NEC				
TR401	2SC1222 (E, U)	NEC				
TR402	2SC1222 (E, U)	NEC				
TR403	2SA750 (E, U)	NEC				
TR404	2SA750 (E, U)	NEC				
TR405	2SA750 (E, U)	NEC				
TR406	2SA750 (E, U)	NEC				
TR407	2SC1222 (E, U)	NEC				
TR408	2SC1222 (E, U)	NEC				
TR409	2SC1222 (E, U)	NEC				
TR410	2SC1222 (E, U)	NEC				
TR411	2SC1222 (U)	NEC				
TR412	2SC1222 (U)	NEC				
TR501AB	2SA992 (E)	NEC				
TR502AB	2SA992 (E)	NEC				
TR503AB	2SA992 (E)	NEC				
TR504AB	2SC1941 (AK, AL1)	NEC				
TR505AB	2SA916 (AK, AL1)	NEC				
TR506AB	2SC1941 (AK, AL1)	NEC				
TR507AB	2SC2275 (Q)	NEC				
TR508AB	2SA985 (Q)	NEC				
TR509AB	2SD745 (2) (R, Q)	NEC				
TR510AB	2SB705 (2) (R, Q)	NEC				
TR511AB	2SA992 (E)	NEC				
TR601	2SD325 (D, E)	SANYO				
TR602	2SB511 (D, E)	SANYO				
TR603	2SD330 (D, E)	SANYO				
TR701	2SC945A (P)	NEC				
TR702	2SC945A (P)	NEC				
TR703	2SA733A (P)	NEC				
TR704	2SC945A (P)	NEC				
TR705	2SD571 (L, K)	NEC				

VARIABLE CAPACITORS			
Ref. No.	Description	R/S Part No.	Mfr's Part No.
VC101-104/ VC201-203 TC104	Tuning Gang (FM: 4 gang, AM: 3 gang) (Includes TC101-103, TC201-203) Trimmer 1ZW10 x 32	C-4721 C-0943	P-150048 P-160016

VARIABLE RESISTORS			
Ref. No.	Description	R/S Part No.	Mfr's Part No.
VR101	Trimmer 22K ohm B	P-6604	P-170372 or P-170440
VR102	Trimmer 47K ohm B	P-6651	P-170373 or P-170442
VR103	Trimmer 1K ohm B	P-6579	P-170367 or P-1700433
VR104	Trimmer 4.7K ohm B	P-6550	P-170370 or P-170437
VR201	Trimmer 1K ohm B	P-6579	P-170367 or P-170433
VR401/402	Potentiometer VOLUME	P-7107	P-171305
VR403/404	Potentiometer BALANCE	P-3119	P-170504
VR405/406	Potentiometer TREBLE	P-4033	P-170505
VR407/408	Potentiometer MIDRANGE	P-5014	P-171304
VR409/410	Potentiometer BASS	P-4033	P-170505
VR501AB	Trimmer 220 ohm B	P-6621	P-171035
VR701/702	Trimmer 100 ohm B	P-6622	P-171033

24) EXPLODED VIEW PARTS LIST

Ref. No.	Description	R/S Part No.	Mfr's Part No.
1.	Front Chassis		P-400288
2	Pre Amp Assembly P.C.B.	X-2195	U-14130
3	Tone Control Assembly P.C.B.	X-8527	U-14131
4	Tuning Shaft	D-3293	P-420361
5	Headphone Jack	J-0919	P-190125
6	Sub-Pulley Holder (A)		P-412185
7	Sub-Pulley Holder (B)		P-412186
8	Sub-Pulley Holder (C)		P-412187
9	Sub-Pulley Holder (Mid)	D-0385	P-610471
10	FM MUTE/Hi-MPX FILTER Switch	S-7499	P-180457
10	SPEAKERS A/B Switch	S-7499	P-180457
11	Switch Assembly P.C.B.	X-8524	U-23164
12	Pointer Rail		P-412191
13	Blind		P-412192
14	Pointer Assembly	D-1322	P-450095
	Consisting of Pointer		P-450095
	Pointer Base		P-610630
	Pointer Sheet		P-480249
15	Dial Plate	D-1323	P-710195
16	Dial Side (L)	D-1324	P-610742
17	Dial Side (R)	D-1325	P-610778
18	Dial Scale (UL, C.S.A.)	D-1326	P-640258
18	Dial Scale (European, Australian)		P-640261
19	Chassis Holder (L)		P-412173
20	Chassis Holder (R)		P-412174
21	Lamp Holder		P-260012
22	Dial Lamp	F-1013	P-240141
23	WATTS Meter (L)	M-0458	P-230097
24	WATTS Meter (R)	M-0459	P-230098
25	Signal Meter	M-0460	P-230099
26	Tuning Meter	M-0461	P-230100
27	Meter Lamp Case	HB-9977	P-610756
28	Tuning Meter Lamp	L-1186	P-240128 or P-240135
29	Signal Meter Lamp	L-1187	P-240129 or P-240136
30	WATT Meter Lamp (R)	L-1188	P-240130 or P-240137
31	WATT Meter Lamp (L)	L-1198	P-240131 or P-240138
32	Plate Spring	RB-6826	P-412278
33	LED Assembly P.C.B.		U-23165
34	Side Chassis		P-400289
35	Chassis Joint		P-412298
36	Center Chassis		P-400290
37	Main Amp Chassis (UL, C.S.A., European)		P-412179
37	Main Amp Chassis (Australian)		P-412198
38	Cushion Seal for Top Cover (A)	HB-7686	P-480146
39	Cushion Seal for Top Cover (B)	HB-7687	P-480147
40	Transformer Holder (A)	RT-2495	P-411903
41	Power Transformer (UL)	TA-0824	P-100748
41	Power Transformer (C.S.A.)		P-100826
41	Power Transformer (European, Australian)		P-100749
42	Bottom Plate (UL, Australian, European)		P-412178
42	Bottom Plate (C.S.A.)		P-412374
43	Thermal Protector (95° C) (UL)		P-290033

Ref. No.	Description	R/S Part No.	Mfr's Part No.
43	Thermal Protector (95° C) (C.S.A. European, Australian)	HB-6880	P-290018
44	Protector Spring	RB-6570	P-411701
45	Heat Sink Holder	HB-9091	P-411902
46	Spacer for Bottom (C)		P-660221
47	Power Switch (UL, C.S.A.)	S-7500	P-180464
47	Power Switch (European, Australian)		P-180349
48	Push Switch (UL, C.S.A.)	S-7501	P-180467
49	Switch Holder (A) (UL, C.S.A.)		P-412222
49	Switch Holder (European, Australian)		P-412194
50	Joint (A) (UL, C.S.A.)		P-610766
50	Joint (European, Australian)		P-610744
51	Line Pass Capacitor (UK535 type or LB type) (UL)		
51	Line Pass Capacitor (MY type) (C.S.A.)		
51	Line Pass Capacitor (RME 271M type) (European, Australian)		
52	Capacitor Cover (UL)	HB-6379	P-610466
52	Capacitor Cover (C.S.A.)		P-610670
52	Capacitor Cover (European)		P-610467
53	Capacitor Holder		P-412193
54	Electrolytic Capacitor		P-220061
55	Spacer for Top (D)		P-660222
56	Rectifier	DX-1117	
57	Transformer Label	HB-7680	P-810047
58	Ground Lug		P-320284
58	Ground Lug (Australian)		P-320152
59	Fuse Assembly P.C.B.		P-200855
60	Consisting of Fuse		P-250008
61	Fuse Holder	F-1013	P-260017
62	Tuner & IF Assembly P.C.B.	X-8523	U-12053
63	P.C.B. Holder (E)		P-412181
64	P.C.B. Holder (F)		P-412180
65	P.C.B. Holder (G)		P-412299
66	Dial Pulley	D-0411	P-610623
67	Dial Spring	RB-6486	P-440156
68	Eyelet		
69	Dial Cord		
70	C-S type Stop Ring		
71	Back Panel (UL)	Z-5646	P-412195
71	Back Panel (C.S.A.)		P-412199
71	Back Panel (European)		P-412200
71	Back Panel (Australian)		P-412201
72	Panel Bracket		P-410938
73	AM Bar Antenna		P-110108
74	Antenna Cushion	HB-9979	P-680207
75	Antenna Terminal	J-4563	P-320218
76	6P RCA Pin Jack for PHONO & AUX	J-0970	P-320151
77	4P RCA Pin Jack for Pre Out & Main In	J-0969	P-320137
78	2P RCA Pin Jack for Speaker	J-6835	P-300347
79	Joint Pin	HB-7828	P-190120
80	4P RCA Pin Jack for TAPE	J-6836	P-320359
81	5P Pin Jack	J-6837	P-320346
82	Tape P.C.B.		P-200850
83	Ground Screw	HD-1305	P-420284
84	4P Push Terminal	J-4604	P-320257
85	AC Outlet (UL, European, Australian)	J-1100	P-190157 or P-190098

Ref. No.	Description	R/S Part No.	Mfr's Part No.
85	AC Outlet (C.S.A.)		P-190157 or P-190324
86	Number Plate (UL)	HB-6879	P-730184
87	Fuse Holder (UL)	F-1017	P-260011
87	Fuse Holder (C.S.A.)		P-260013
87	Fuse Holder (European, Australian)		P-260015
88	AC Cord (UL, C.S.A.)	W-1000	P-310115
88	AC Cord (Australian)		P-310041
88	AC Cord (European)		P-310091
89	AC Cord Strain Relief (UL, C.S.A., European)	HB-0705	P-480010
89	AC Cord Strain Relief (Australian)		P-480165
90	Insulation for Front Chassis (A)		P-480313
91	Insulation for Center Chassis (B)		P-480314
92	Front Panel (UL, C.S.A., Australian) (Use for Serial No. 1 - 11480) (Use after Serial No. 11481)	Z-5680	P-700470 P-700489
92	Front Panel (European) (Use for Serial No. 1 - 590) (Use after Serial No. 591)		P-700471 P-700490
93	Panel Window		P-640259
94	Knob Base for Tuning (A)		P-610739
95	Knob Base for Volume (B)		P-610740
96	Knob Guide		P-610741
97	Switch Cover for Lever		P-610416
98	Side Board (L)	Z-5647	P-630131
99	Side Board (R)	Z-5648	P-630132
100	Cabinet Bracket		P-411048
101	Screw Cover	HB-5105	P-610397
102	Top Cover	Z-5649	P-412177
103	Panel Holder (L)		P-412183
104	Panel Holder (R)		P-412184
105	Tuning Knob (457)	K-4228	P-650457
106	Volume Knob (458)	K-4229	P-650458
107	Tone & Selector Knob (459)	K-4230	P-650459
108	Lever Switch Knob (201)	K-2300	P-650201
109	Push Knob (478)	K-4231	P-650478
110	Foot	F-0205	P-610428
111	Main Amp Assembly P.C.B.	Z-8525	U-16107
112	Heat Sink		P-412176
113	Main Amp P.C.B. Holder (C)		P-412197
114	Main Amp P.C.B. Holder (D)		P-412182
115	Power Supply Assembly P.C.B.	X-8522	U-17082
117	Power Supply P.C.B. Bracket (A)		P-411893
118	Power Supply P.C.B. Bracket (B)		P-411894
116	Protector Assembly P.C.B.	X-8526	U-23163
117	Protector P.C.B. Bracket (A)		P-411893
118	Protector P.C.B. Bracket (B)		P-411894
119	Blind Sheet		P-660126
120	Blind Sheet for Lever Switch		P-660167
121	Cushion (Black)		P-680262
122	Cushion (Black) for Tone P.C.B.		P-680269

HARDWARE	
Ref. No.	Description
S1	Tapping Screw 3 x 6BT-2
S2	Sems-A Screw 3 x 6P+3SW
S3	Stop Screw 3 x 9 x 3P
S4	Stop Screw 3 x 12 x 4P
S5	F-Lock Screw 3 x 6P-FL
S6	Tapping Screw 3 x 8PT-2
S7	Tapping Screw 4 x 8BT-3-DEL
S8	Tapping Screw 3 x 10-2
S9	Tapping Screw 4 x 16BT-2
S10	Toothed Tapping Screw (Black) 3 x 6 BT-2
S11	F-Lock Screw (Black) 3 x 6P-F
S12	Tapping Screw (Black) 3 x 8PT-PLAX
S13	Wood Screw 3.1 x 10PW
S14	Tapping Screw (Black) 4 x 20BT-3-DEL
S15	Tapping Screw (Black) 3 x 8BT-2
S16	Tapping Screw 3 x 8RFT-3-DEL
S17	Tapping Screw 3 x 18BT-3-DEL
S18	Triple Screw 3 x 16P
S19	Tapping Screw 3 x 8PT-PLAX
S20	Triple Screw 3 x 4P
S21	Tapping Screw 4 x 16BT-3-DEL
S22	Tapping Screw 3 x 8BT-3-DEL
W1	Outer Toothed Washer 3W
W2	Washer 3W
W3	Washer (Black) 5W
N1	Frage Nut 4N-F
R1	Blind Rivet (YB-320) (Black)

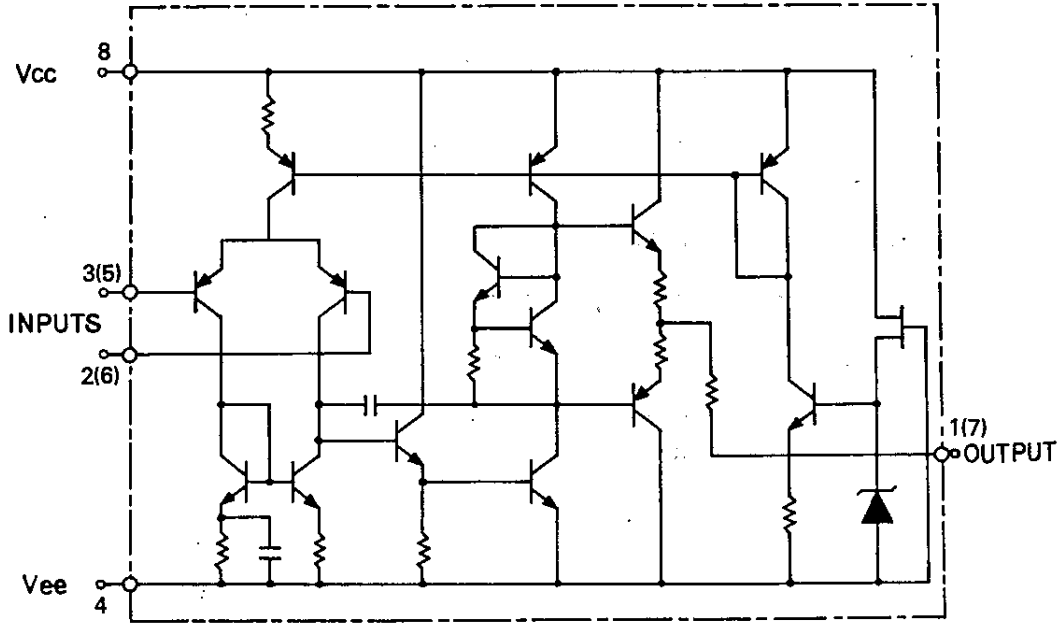
25) MISCELLANEOUS PARTS LIST

Description	R/S Part No.	Mfr's Part No.	Description	R/S Part No.	Mfr's Part No.
Solderless Terminal	H-3305	P-320006	[Main Amp Assembly P.C.B.]		
Solderless Terminal (UL, C.S.A.)			2P Pin Terminal (I type) (Male)		P-320271
Thermal Protector (90°)(C.S.A.)		P-290019	2P Connector (I type) (Female)		P-190216
Switch Cover (Australian)		P-480145	5P Pin Terminal (I type) (Male)		P-320280
Ground Bar	HB-7822	P-411433	5P Connector (I type) (Female)		P-190204
AC Outlet Cover (European)		P-411205	3P Pin Terminal (I type) (Male)		P-320272
Outlet Cover Label (European)		P-810503	3P Connector (I type) (Female)		P-190196
Plate Spring (C.S.A.)		P-440207	[Power Supply Assembly P.C.B.]		
Block Terminal (Australian)		P-320251	3P Pin Terminal (L type)		P-320349
Inner Toothed Washer (Australian)			4P Pin Terminal (L type)		P-320080
Net		P-660210	9P Pin Terminal (L type)		P-320236
Fuse Caution Label (UL, Australian, European)	HB-7046	P-810308	[Protector Assembly P.C.B.]		
Fuse Caution Label (C.S.A.)		P-810584	5P Pin Terminal (L type)		P-320177
LED Base	HB-9976	P-610743	6P Pin Terminal (L type)		P-320163
Eyelet			[Tuner & IF Assembly P.C.B.]		
Sheet (A) for Dial Scale (Use after Serial No. 8001)		P-660228	Shield Case (A)		P-412188
Meter Tape		P-690347	Shield Case (B)		P-412199
			Shield Plate		P-411296
			Shield Plate (B)		P-412274

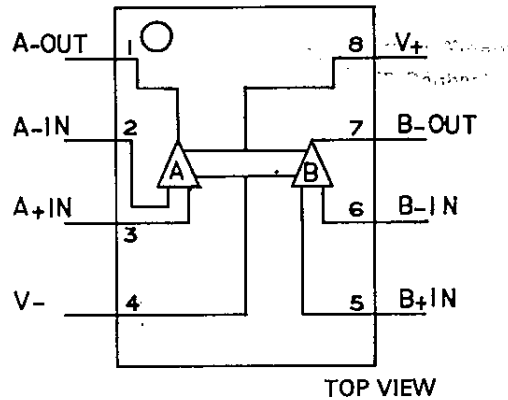
26) IC INTERNAL DIAGRAM

NJM-4558DX

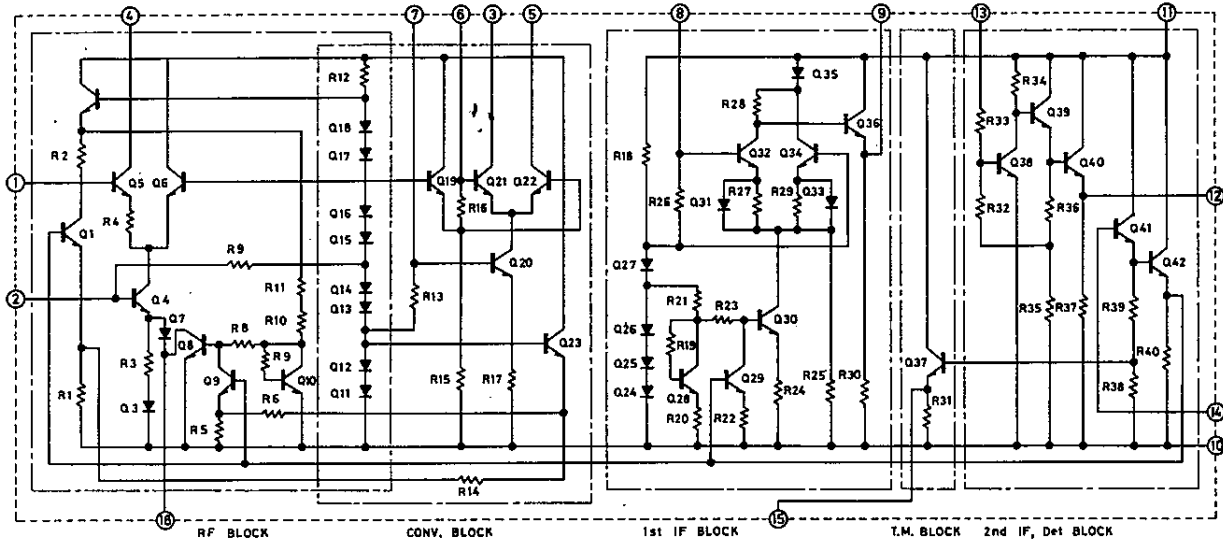
SCHEMATIC DIAGRAM



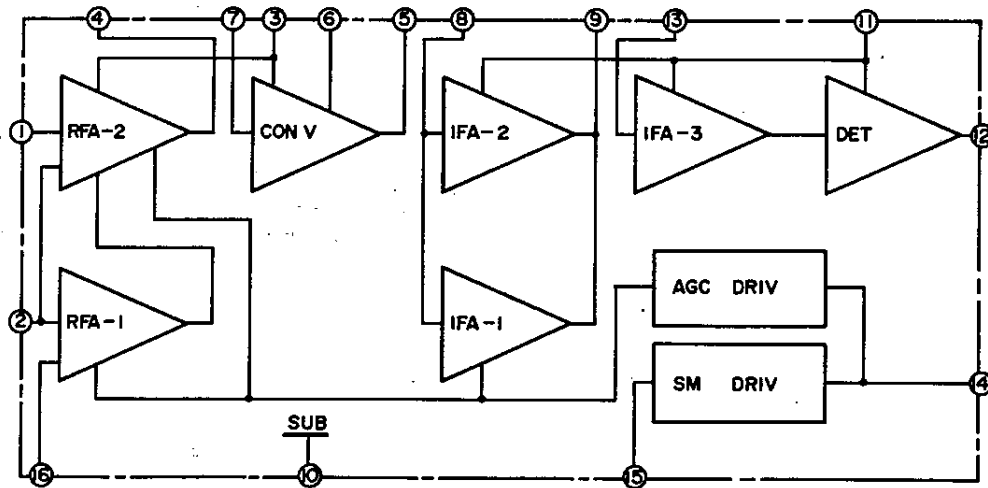
BLOCK DIAGRAM



SCHEMATIC DIAGRAM

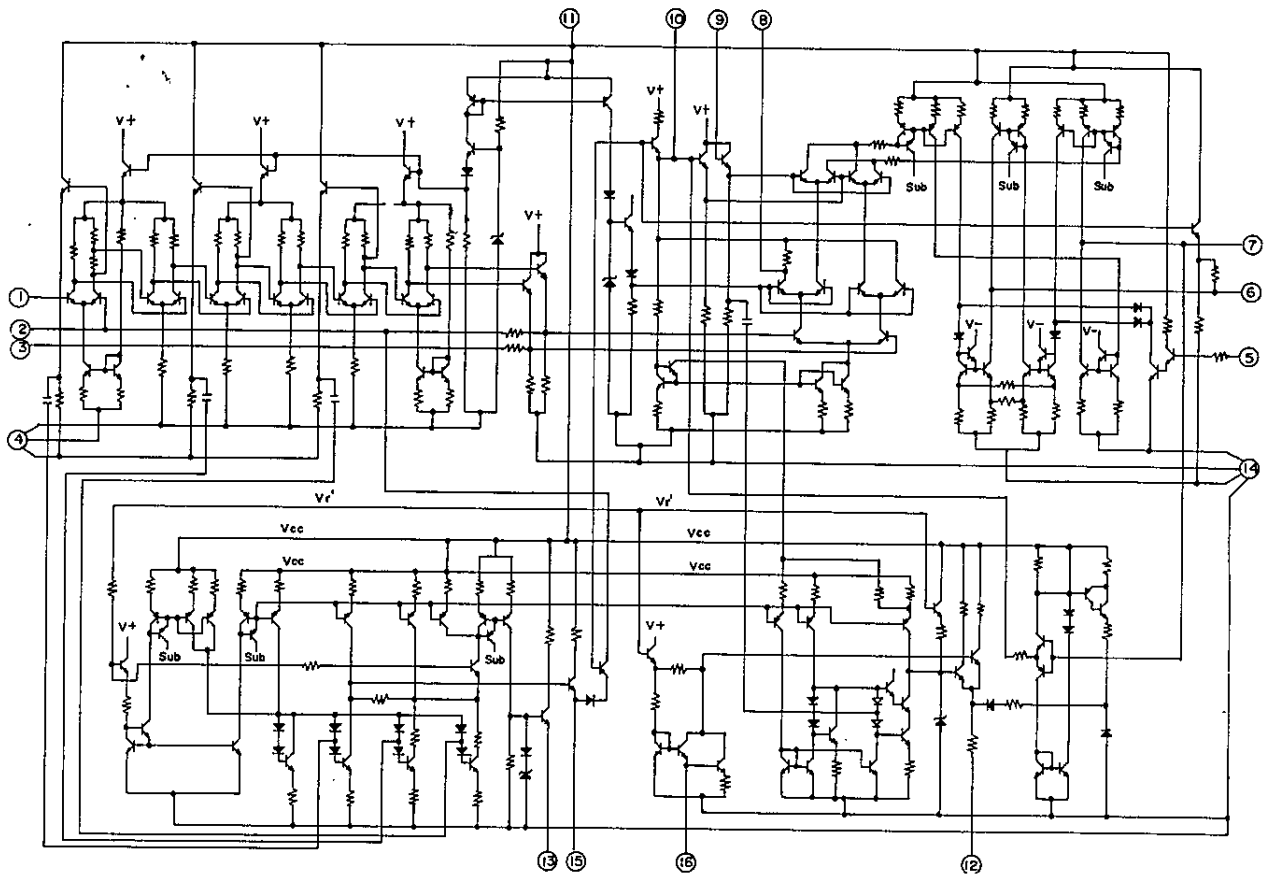


BLOCK DIAGRAM



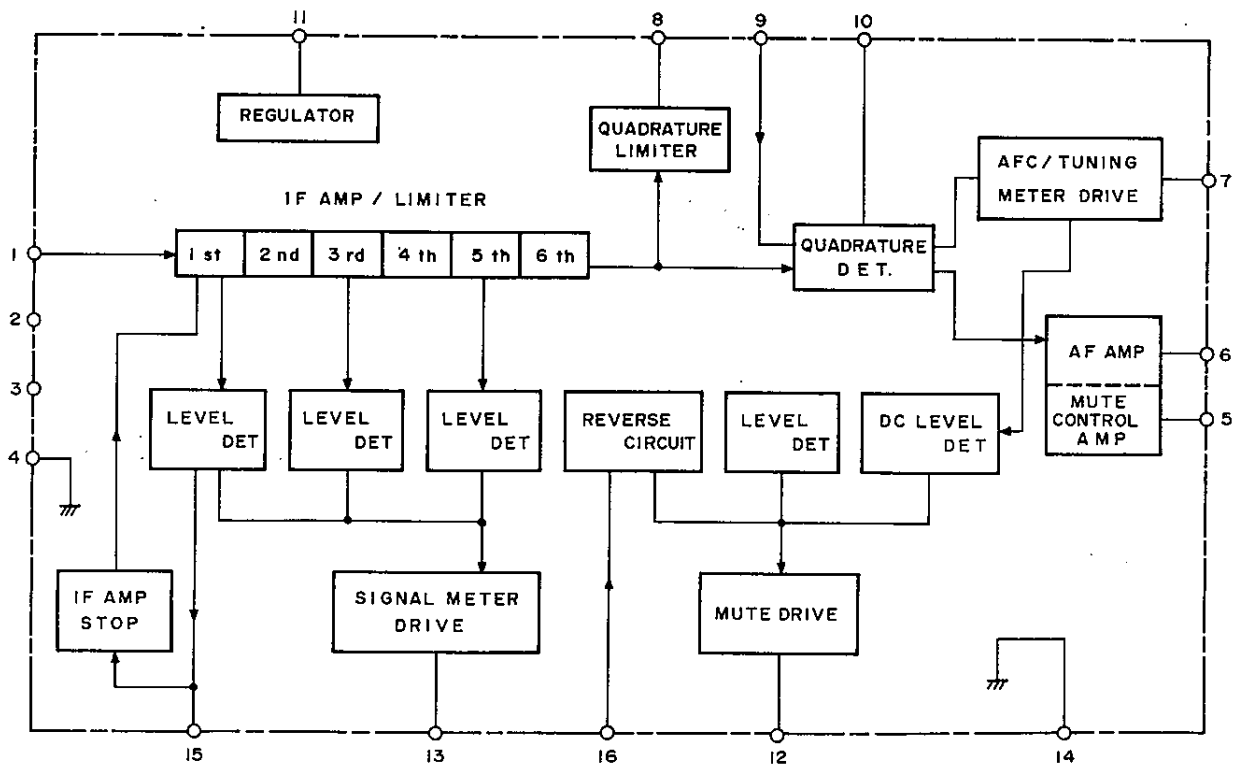
LA-1231

SCHMATIC DIAGRAM

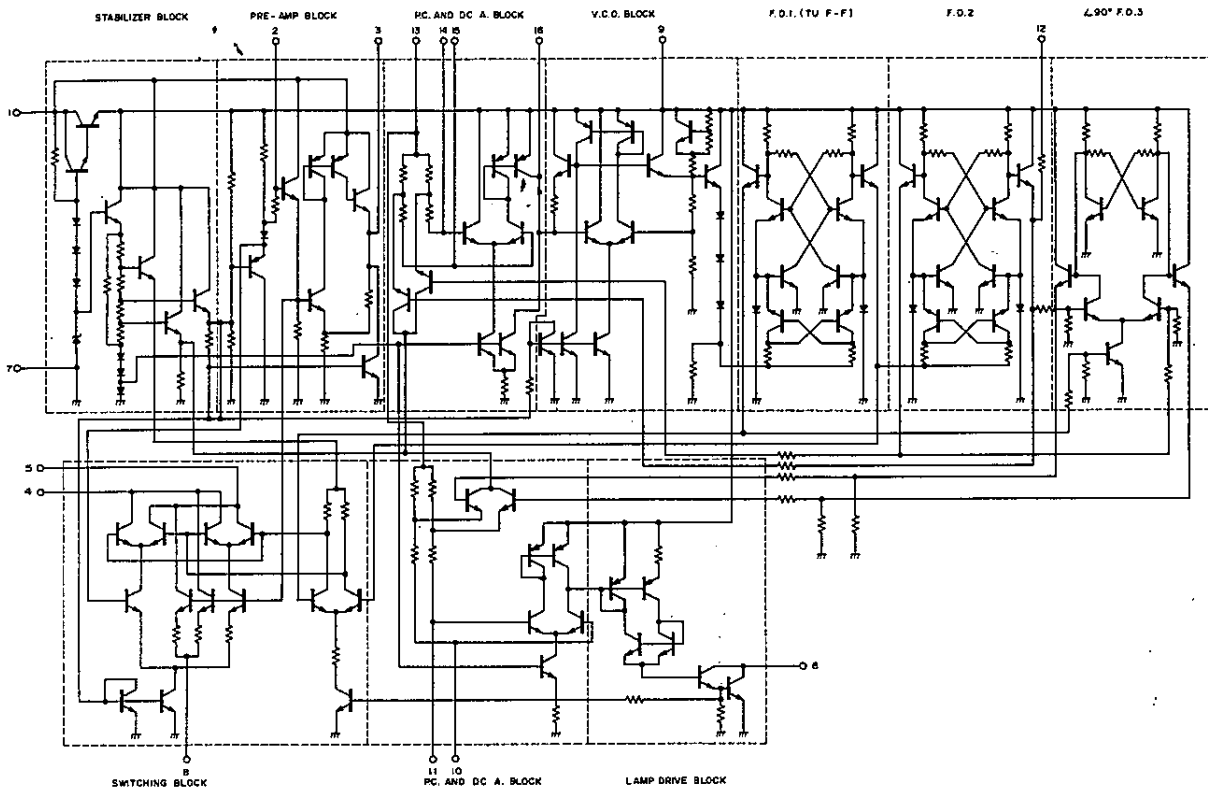


LA-1231N

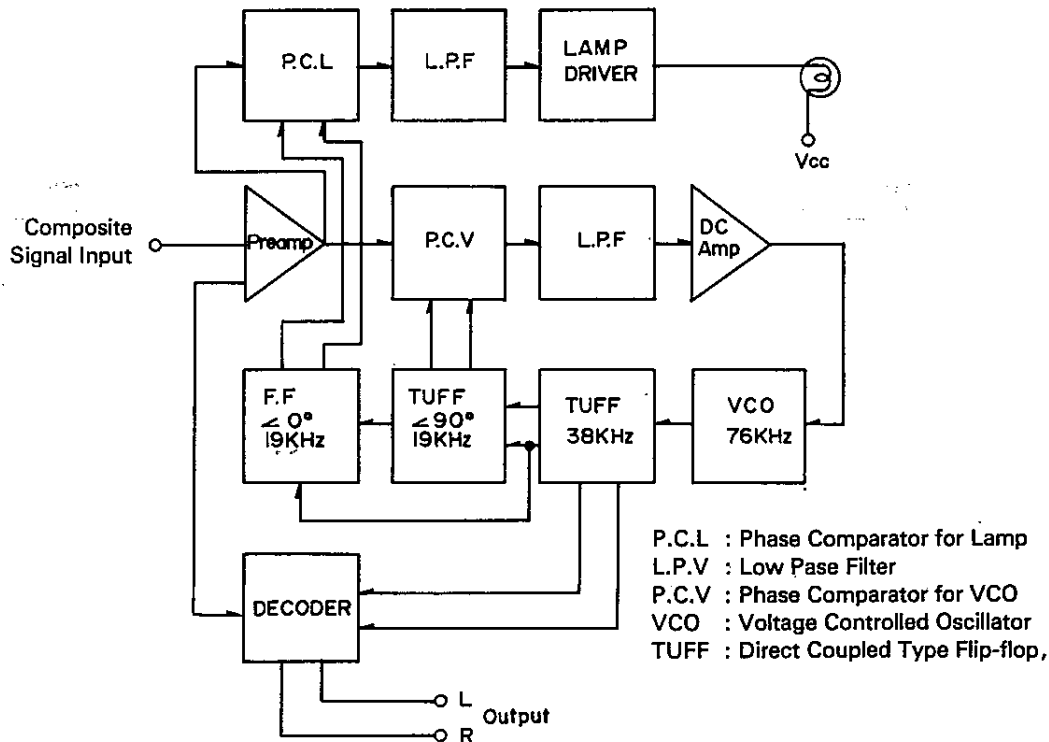
BLOCK DIAGRAM



SCHMATIC DIAGRAM

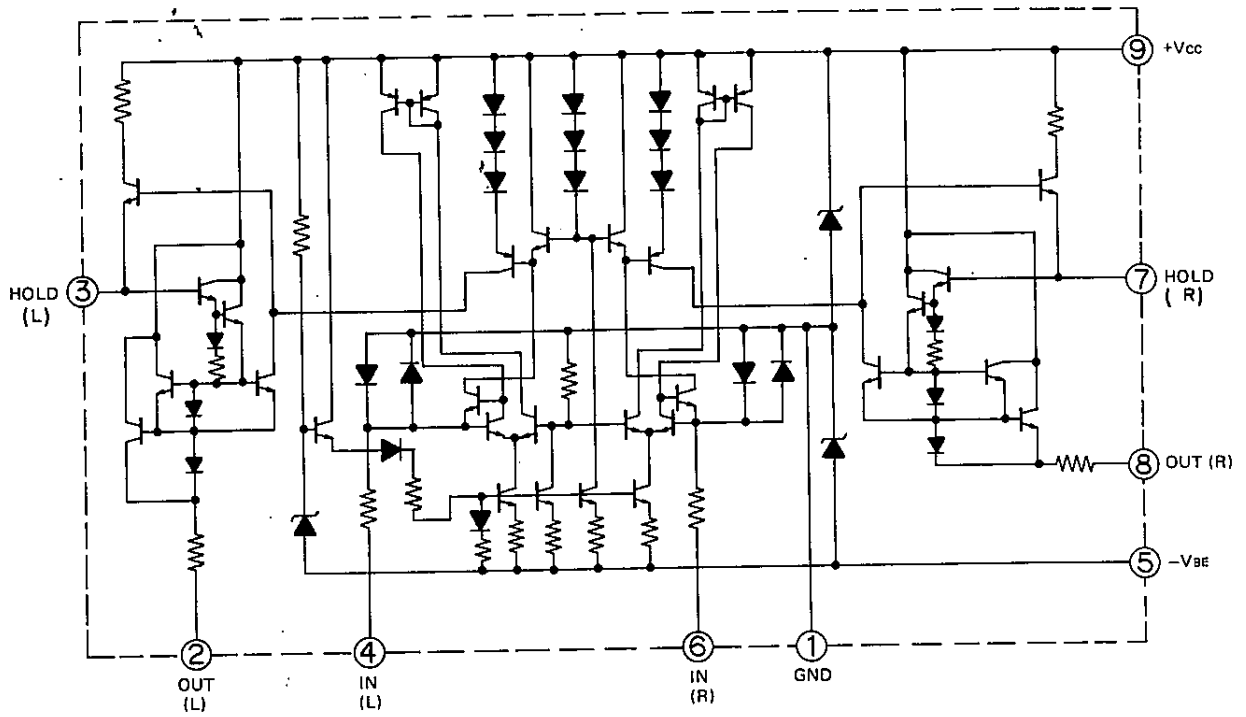


BLOCK DIAGRAM

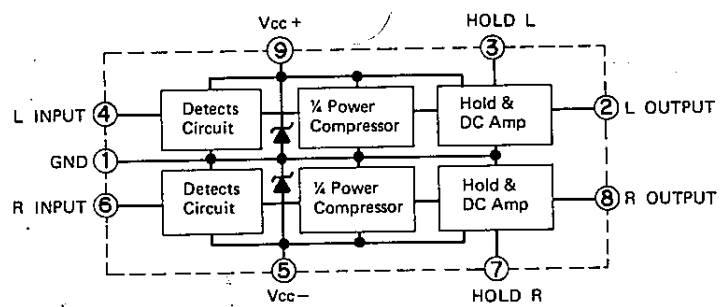


TA-7318P

SCHMATIC DIAGRAM



BLOCK DIAGRAM



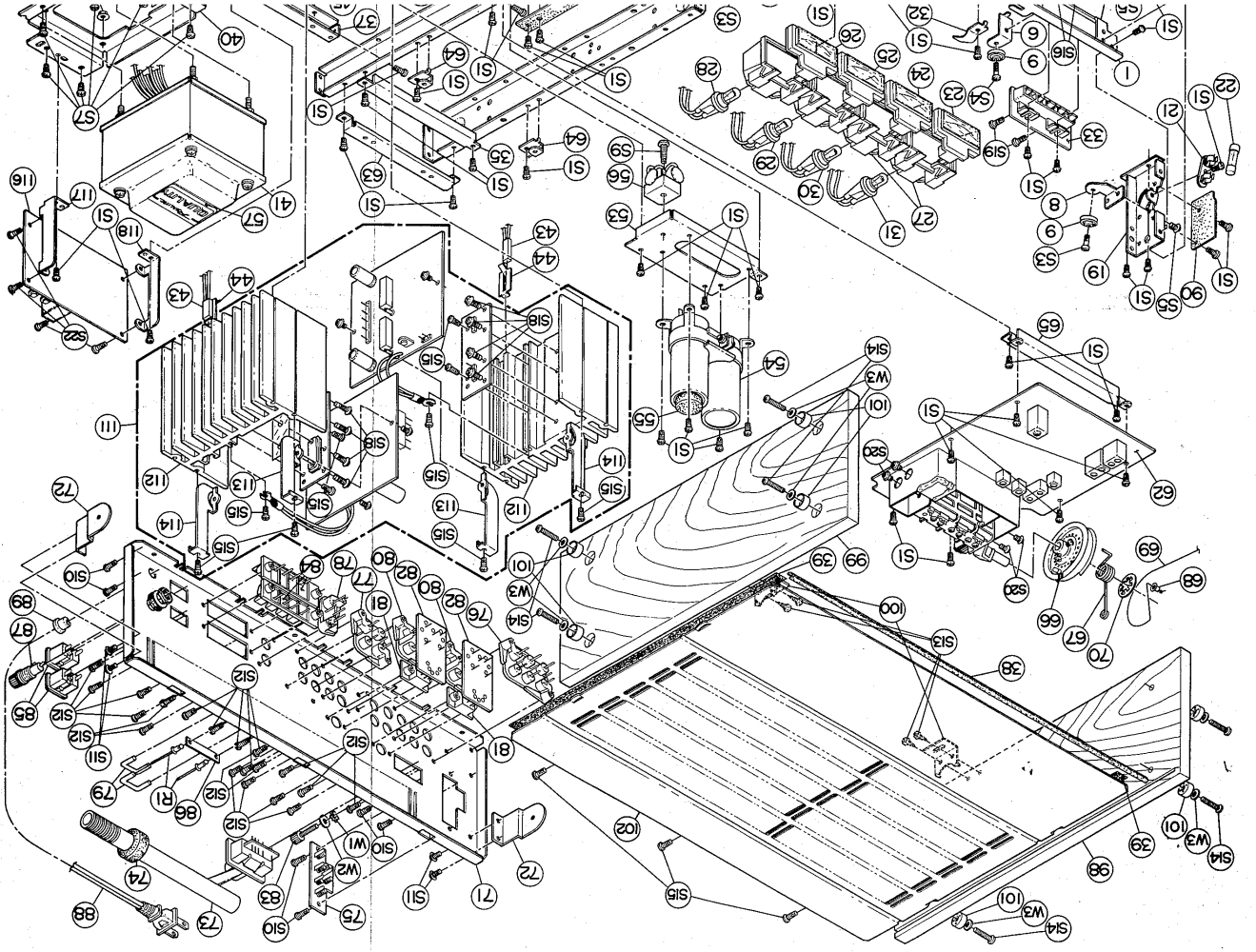
27) VOLTAGE CHART FOR PRE AMP & PROTECTOR CIRCUITS

MUTING CIRCUIT						
Ref. No.		AUDIO MUTING OFF (V)	RELAY ON (V)	AUDIO MUTING ON (V)	FM MUTING ON (V)	FM MUTING OFF (V)
TR309	E	0.032	0.029	0.063	0.7	0.41
	C	20.2	18.3	0.135	0.7	19.8
	B	-1m	-3m	-3m	1.25	0.69
TR310	E	0	0	0	0	0
	C	20.2	18.3	0.135	0.7	19.8
	B	0.032	0.029	0.063	0.7	8.41
TR311	E	0	0	0		
	C	0.039	0.37	0.737		
	B	0.012	0.608	1m		
TR312	E	0	0	0		
	C	20.2	18.3	0.135		
	B	39m	37m	0.737		

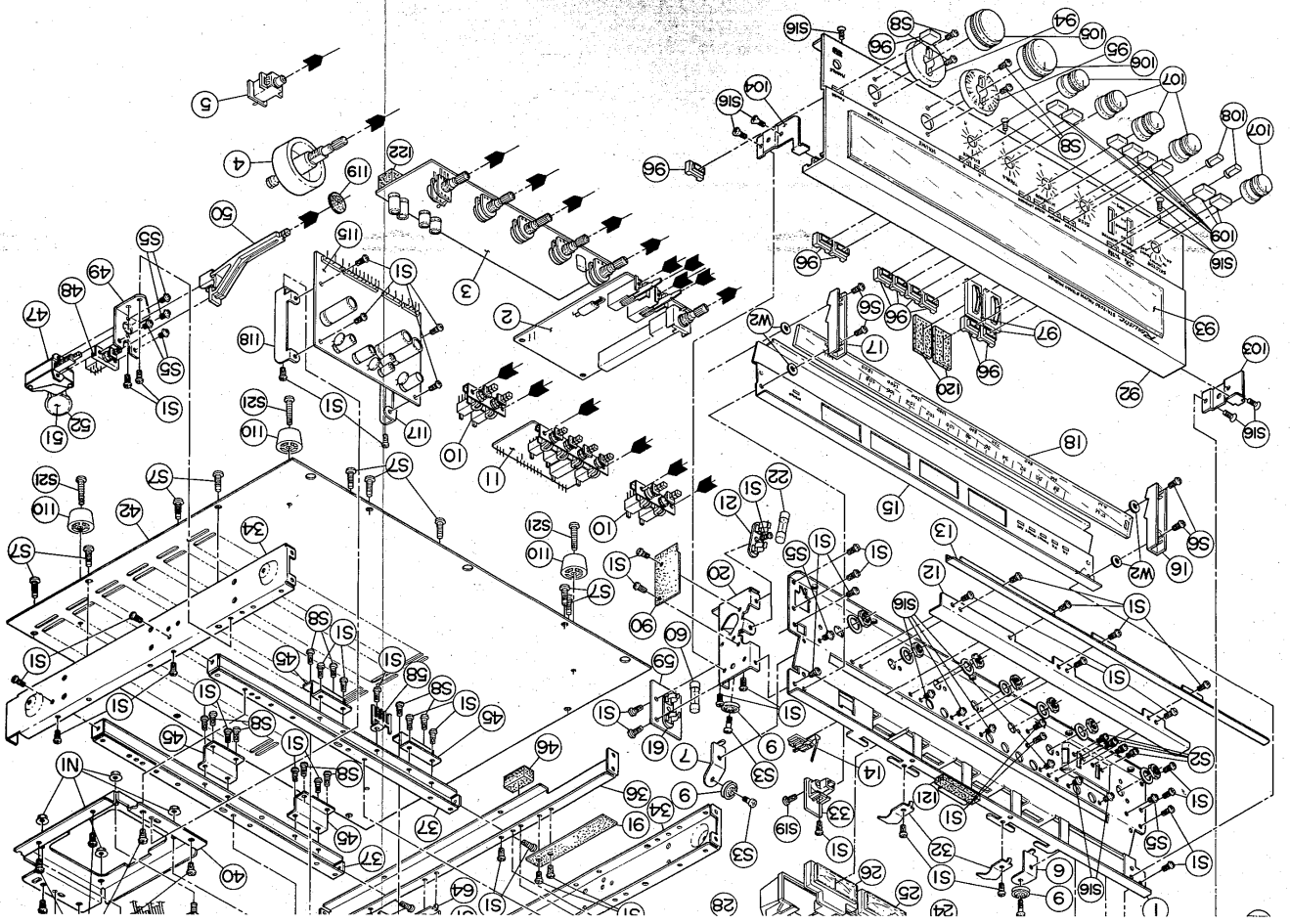
WATTS METER CIRCUIT								
Ref. No.		WATTS Meter Pointer Position						
		0W (V)	0.1W (V)	1.0W (V)	10.0W (V)	20W (V)	50W (V)	80W (V)
IC701	1	0	0	0	0	0	0	0
	2	-8.31	-8.18	-8.13	-8.04	-8.01	-7.96	-7.92
	3	-1.44	-1.30	-1.28	-1.21	-1.18	-1.11	-0.89
	4	-0.06	-0.06	-0.05	-0.03	-0.02	-0.04	0.11
	5	-8.31	-8.25	-8.21	-8.17	-8.15	-8.13	-8.11
	6	-0.06	-0.06	-0.05	-0.03	-0.02	-0.003	0.10
	7	-1.21	-1.18	-1.16	-1.14	-1.11	-1.01	-0.75
	8	-8.30	-8.18	-8.12	-8.04	-8.01	-7.95	-7.92
	9	8.33	8.28	8.24	8.20	8.18	8.15	8.13

Ref. No.		FM 98 MHz 1 mV Input	
		MONO (V)	STEREO (V)
TR109	E	0	0
	C	10m	2.17
	B	0.63	0.46

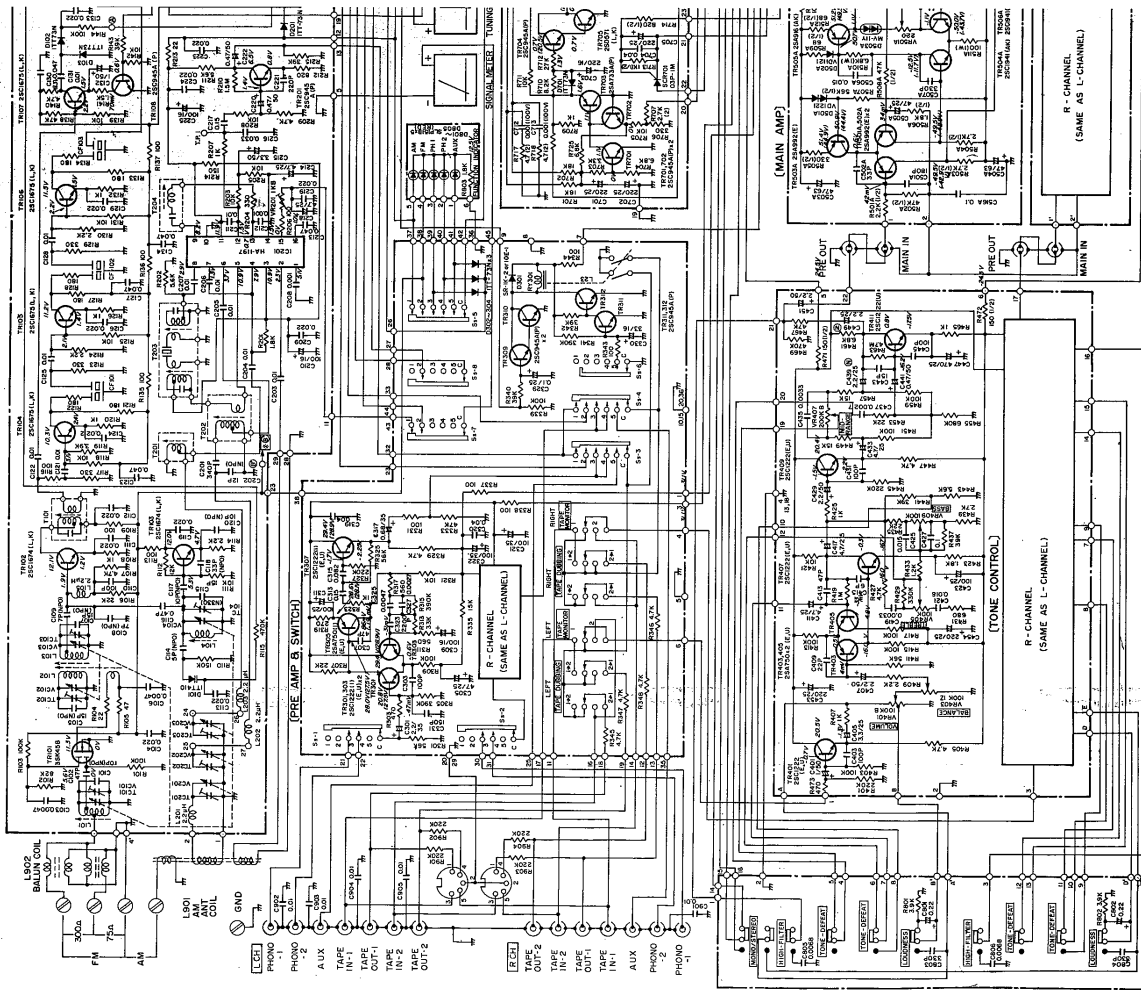
29) EXPLODED



EXPLODED VIEW

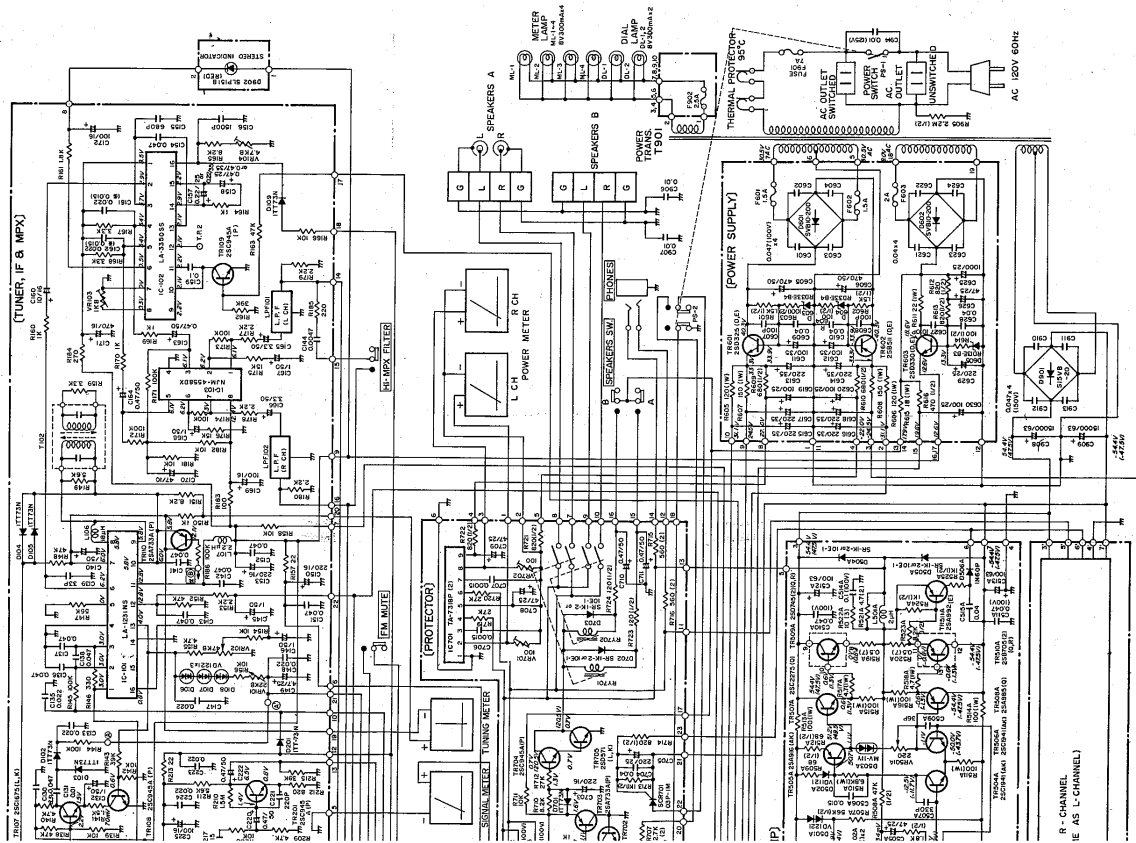
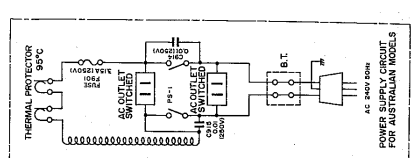
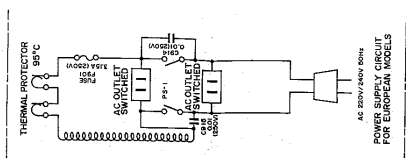
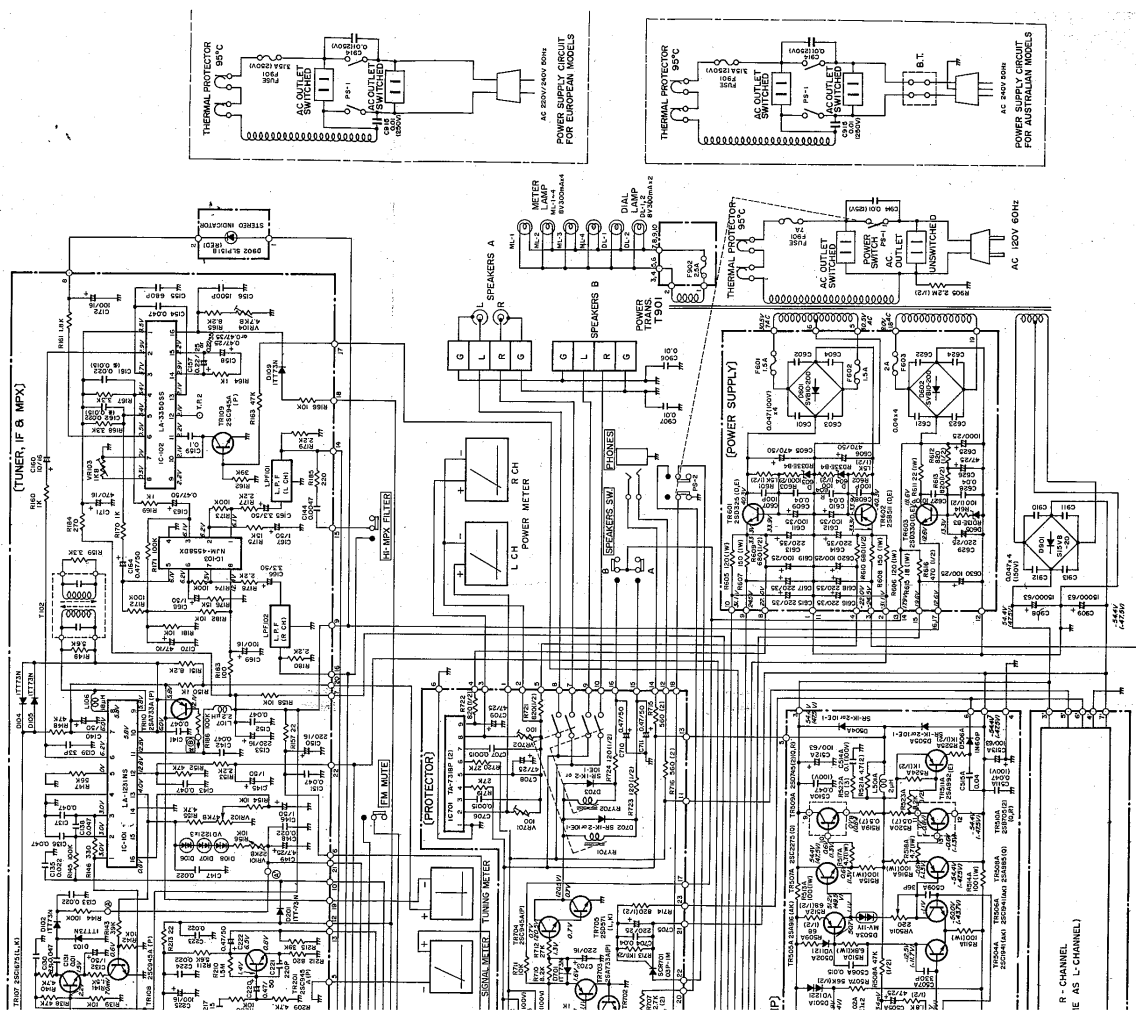


28) SCHEMATIC DI/



- NOTE:
- (1) SS-6 SELECTOR SWITCH 1-AM, 2-FM, 3-PHONO 1, 4-PHONO 2, 5-AUX.
 - (2) PS-1 - PS-2 POWER SWITCH.
 - (3) ALL CAPACITANCE VALUES ARE INDICATED IN "μF" (P = 10⁶ μF).
 - (4) ALL RESISTANCE VALUES ARE INDICATED IN "Ω" (K = 10³ Ω, M = 10⁶ Ω).
 - (5) THE PARENTHESES VALUES ON AUDIO CIRCUITS ARE INDICATED IN "WATT".
 - (6) VALUES IN FM IF STAGE ARE FOR EUROPEAN AND AUSTRALIAN MODELS.
 - (7) VOLTMETER OVER 100ΩV WITH RECEIVER DETUNE IN DIGITAL MODELS.
 - (8) VOLTAGE ON AUDIO STAGE ARE MEASURED UNDER TWO CONDITIONS:
WITH NO INPUT AND 80 WATTS/Ω (1.1 kHz) OUTPUT POWER (INSIDE PARENTHESES).

WIRING DIAGRAM



R-CHANNEL
IE AS L-CHANNEL