

REALISTIC[®]

Service Manual

31-4016

QTA-770

CD-4-SQ FOUR CHANNEL STEREOMAX RECEIVER

Catalog Number : 31-4016

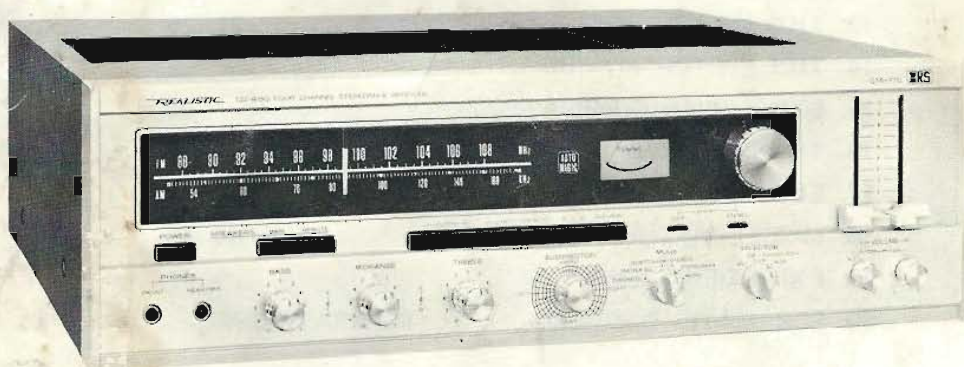

CUSTOM MANUFACTURED FOR RADIO SHACK  A TANDY CORPORATION COMPANY

CONTENTS

	PAGE
1. SPECIFICATIONS	3-5
2. BLOCK DIAGRAM	6
3. DISASSEMBLY INSTRUCTIONS	7
4. DIAL STRINGING DIAGRAM	7
5. CHASSIS LAYOUT	8&9
6. ALIGNMENT PROCEDURES	10-14
7. LEVEL DIAGRAM	15
8. ALIGNMENT POINTS	16
9. TROUBLE SHOOTING	17-22
10. 0019 TUNER BOARD	23-24
11. 0021 TONE AMP BOARD	25
12. 6037 MAIN AMP BOARD	26
13. 7100 CD-4 DEMODULATOR BOARD	27&28
14. 7101 SWITCH BOARD	29
15. 8024 POWER SUPPLY BOARD	30
16. TRANSISTOR & IC LEAD IDENTIFICATION	31
17. ELECTRICAL PARTS LIST	32-43
18. MISCELLANEOUS PARTS LIST	44-45
19. EXPLODED VIEW	47
20. SCHEMATIC DIAGRAM	SEPARATE SHEET

SPECIFICATIONS

	NOMINAL	LIMIT	UNIT
FM SECTION			
1. TUNING RANGE *European models must not be able to tune below 87.5 MHz	*87.5-108.5	88-108	MHz
2. DIAL CALIBRATION ACCURACY 90 & 106 MHz		±260	kHz
98 MHz		±350	kHz
3. USABLE SENSITIVITY (Noise & Distortion -30 dB)	1.9	3.0	μV
4. IMAGE REJECTION (at 106 MHz)	75	60	dB
5. IF REJECTION (at 90 MHz)	100	80	dB
6. LIMITER SENSITIVITY (at -3 dB below maximum audio)	1.5	2.0	μV
7. THD at 98 MHz 1 mV at 400 Hz, 100% MOD	0.5	1	%
8. IF BANDWIDTH 6 dB down		±150	kHz
9. SIGNAL-TO-NOISE RATIO (100% MOD, 1 mV Input)	65	60	dB
10. CAPTURE RATIO (1 mV Input)	1.5	3.5	dB
11. ALTERNATE CHANNEL SELECTIVITY (100 μV Input)	75	60	dB
12. DE-EMPHASIS (at 50-10000 Hz)	±1.5	±2	dB
13. DISCRIMINATOR BANDWIDTH (Peak-to-Peak)	400	300	kHz
14. OUTPUT VOLTAGE Mono	1.4	1.4±2 dB	V
(400 Hz, 100% MOD) Stereo	1.3	1.3±2 dB	V
15. MUTING THRESHOLD	5	3-16	μV
16. OVERLOAD (THD at 98 MHz 100% MOD) (100 mV Input)	1	1.5	%
17. SPURIOUS RESPONSE at 98 MHz (Antenna Input 3 μV, ½IF, 103.35 MHz, at 300 ohm ANTENNA TERMINAL)	80	70	dB
18. SIGNAL STRENGTH METER SENSITIVITY SCALE 2 – SCALE 3	20	12-50	μV
19. AFC HOLDING RANGE (With 1 mV Signal)	±1000	±800	kHz
FM MPX SECTION			
1. STEREO SEPARATION 100 Hz	30	22	dB
(L+R: 45%, L-R: 45% mod., 1 kHz	35	26	dB
1 mV Input) 10 kHz	20	15	dB
2. THD at 98 MHz (1 mV at 1 kHz 100% MOD)	0.8	1.5	%
3. AUTOMATIC STEREO THRESHOLD	10	3-16	μV
4. RESIDUAL 19 kHz & 38 kHz (at 98 MHz 1 mV Input)	50	40	dB
5. SUPPRESSION OF SCA INTERFERENCE (at 98 MHz 1 mV Input)		40	dB

		NOMINAL	LIMIT	UNIT
AM SECTION				
1. TUNING RANGE		525-1650	535-1605	kHz
2. DIAL CALIBRATION ACCURACY	600 kHz		±15	kHz
	1000 kHz		±30	kHz
	1400 kHz		±40	kHz
3. USABLE SENSITIVITY 400 Hz 30% MOD.				
(Noise & Distortion: -20 dB)	Radiated	250	500	μV/in
	Direct	25	50	μV
4. IMAGE REJECTION (at 1400 kHz)		65	50	dB
5. IF REJECTION (at 600 kHz)		60	50	dB
6. AGC FIGURE OF MERIT FROM		45	40	dB
100 mV/m at 1000 kHz				
7. THD 400 Hz 30% MOD at 1000 kHz		1.5	2.5	%
(5 mV/m Input)				
8. BANDWIDTH 6 dB DOWN			4-8	kHz
(at 1000 kHz with antenna input of 5 mV/m)				
9. OUTPUT VOLTAGE				
(400 Hz 30% MOD 5 mV/m input)		300	200	mV
10. AUDIO RESPONSE at 2 kHz				
(at 1000 kHz)			-3	dB
11. SELECTIVITY	200 μV/m	25	20	dB
12. AM Beat	5 mV/m	3	10	%
AUDIO SECTION				
1. RMS OUTPUT POWER (1% THD, 20 Hz - 20 kHz)				
BTL (STEREO MAX)	8 ohm	70	60	W/Channel
4 CHANNEL DRIVEN	8 ohm	28	25	W/Channel
"	4 ohm	30	26	W/Channel
"	4 ohm 1 kHz	33	30	W/Channel
2. IM DISTORTION at 20 W	(70/7 kHz 4/1)	0.3	1	%
3. FREQUENCY RESPONSE				
(AUX 1 W 8 ohm load)	+1.5 dB - 4 dB	20-50,000	20-20,000	Hz
4. INPUT SENSITIVITY (for 25 W)				
PHONO (MAG):	LOW =	0.8	0.8±0.2	mV
(Max BALANCE)	HIGH =	1.6	1.6±0.3	mV
AUX:		230	230±30	mV
TAPE MONITOR:		230	230±30	mV
5. INPUT IMPEDANCE				
PHONO (MAG):		100K		ohms
AUX:		70K		ohms
TAPE MONITOR:		70K		ohms
6. PHONO INPUT EQUALIZATION 30 - 15,000 Hz			RIAA ±2	dB
7. PHONO AMP OVER LOAD CAPABILITY				
(at 1% THD)		15 mV	12 mV	mV
(PHONO level at LOW and max BALANCE)				
8. TONE CONTROL				
BASS	100 Hz	±8	±8+2	dB
TREBLE	10 kHz	±10	±10±2	dB
MIDRANGE	1.5 kHz	±6	±6 ±2	dB
9. HIGH FILTER	10 kHz	-6	-6+2	dB
10. LOW FILTER	70 Hz	12	12 ±2	dB

	NOMINAL	LIMIT	UNIT
11. LOUDNESS COMPENSATION (-30 dB)			
50 Hz	12	12 ±2	dB
100 Hz	9	9 ± 2	dB
10 kHz	5	5 ± 2	dB
12. CHANNEL SEPARATION (AUX input, 8 ohm 10 V Out) 1,000.Hz	45	40	dB
13. SIGNAL TO NOISE RATIO (PHONO level at LOW and max BALANCE)			
PHONO INPUT:	60	40	dB
AUX INPUT:	75	60	dB
14. RESIDUAL NOISE	0.8	2	mV
15. LOAD IMPEDANCE		4-16	ohms
16. POWER SOURCE		110-130	V
17. HARMONIC DISTORTION (at 20 W)			
60 Hz AC			
100 Hz	0.06	0.3	%
1 kHz	0.06	0.3	%
10 kHz	0.1	0.5	%
18. CD-4 SEPARATION F-R	21	17	dB

DISASSEMBLY INSTRUCTIONS

- 1) Removing the chassis from Wooden Cabinet (Figure A).
Remove the six screws (#97 & #91) from the both sides of Wooden Cabinet and Cabinet bottom,
- 2) Removing the Front Panel.
 - a) Remove the knobs from BASS, MIDRANGE, TREBLE, AUDIOROTOR, MODE, SELECTOR, BALANCE, VOLUME and TUNING controls.
 - b) Remove six screws (#17) from both sides and bottom of Front Panel and remove panel.

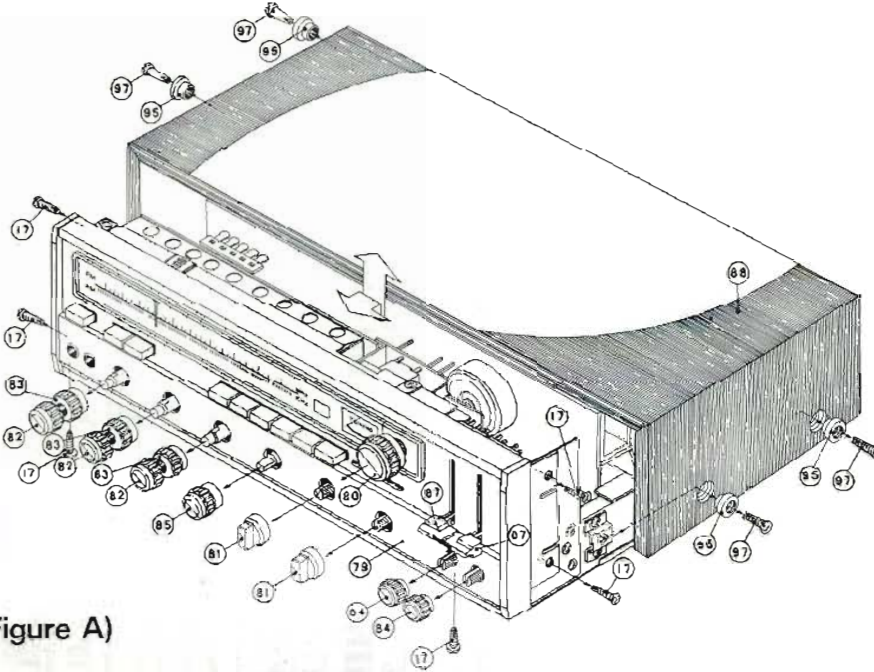

(Figure A)

DIAL STRINGING DIAGRAM

Note: Tuning Capacitor should be fully closed.

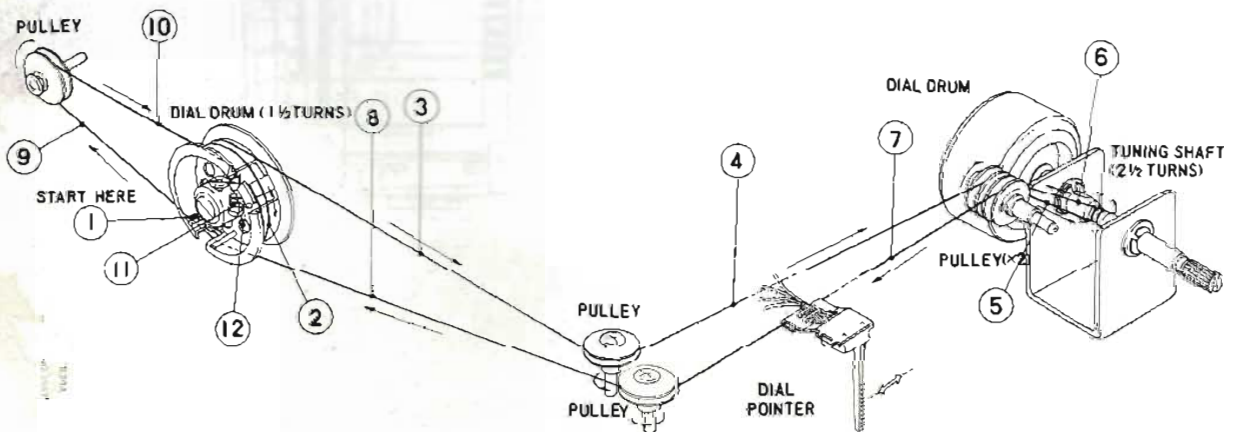

CHASSIS LAYOUT (TOP VIEW)

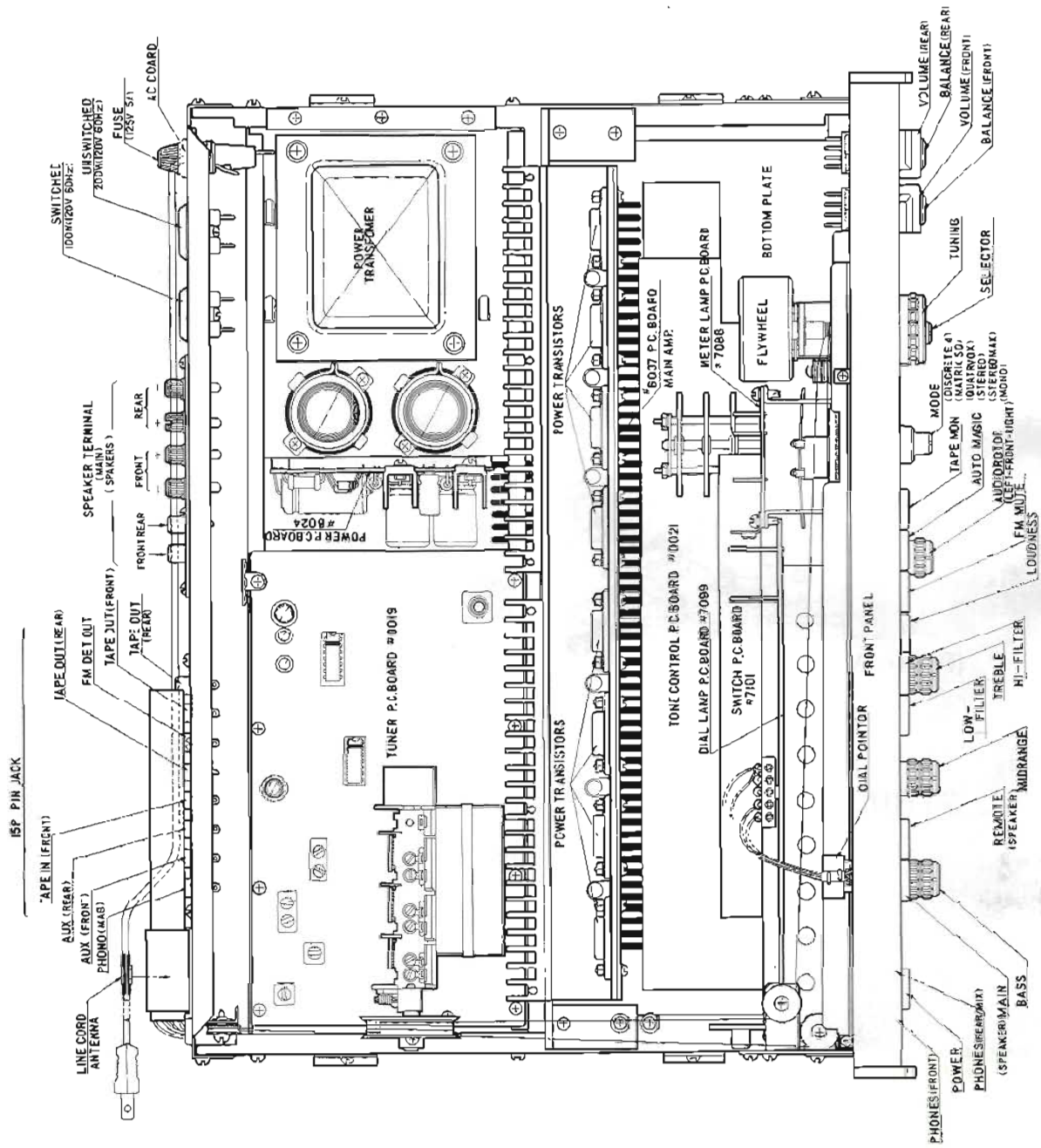

CHASSIS LAYOUT (BOTTOM VIEW)

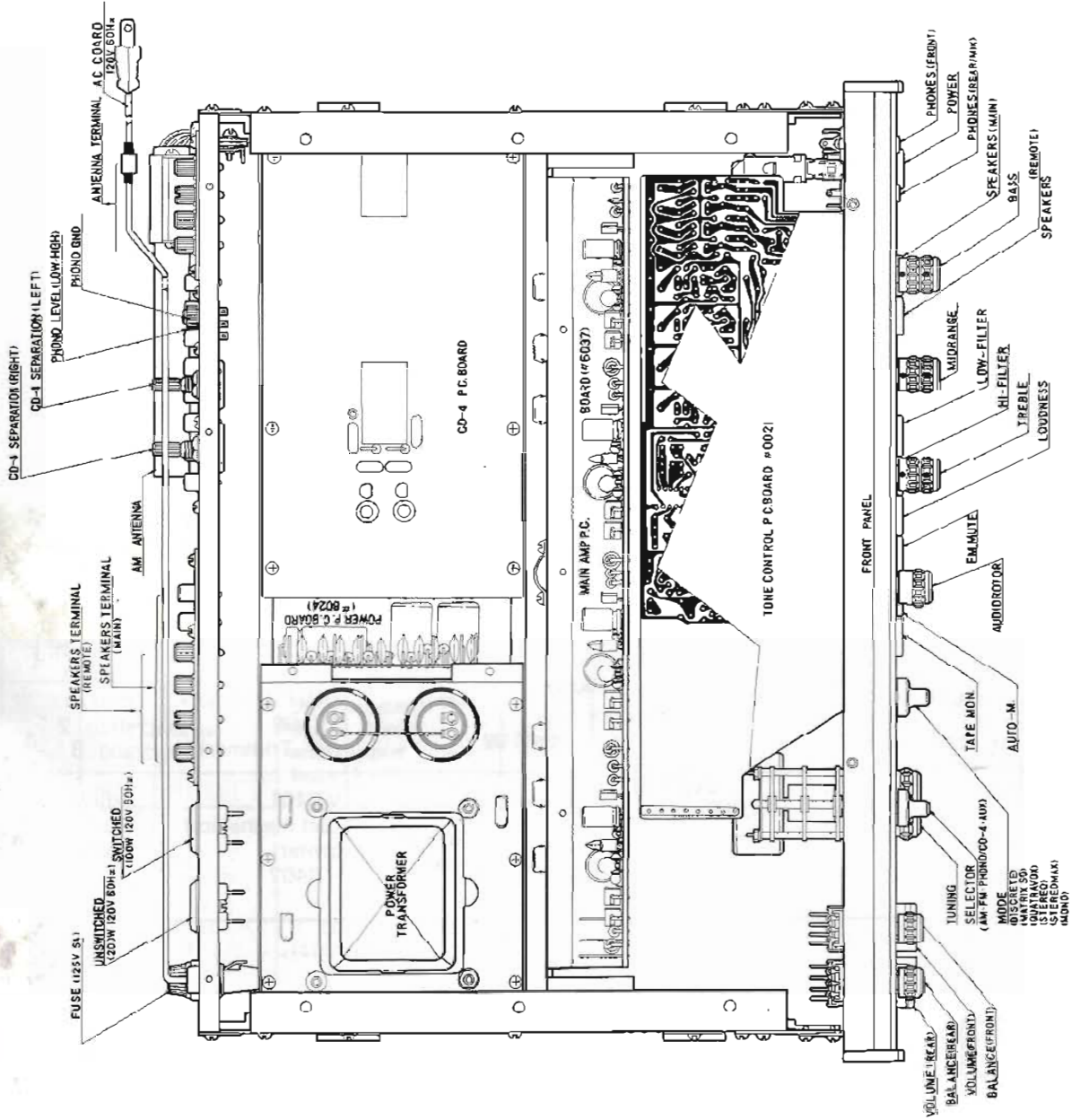

ALIGNMENT PROCEDURE

Do not attempt alignment unless the following equipment is available.

- | | | |
|------------------------|---------------------------|---|
| 1. AM Signal Generator | 5. Stereo Modulator | 9. DC Voltmeter |
| 2. Oscilloscope | 6. Distortion Meter | 10. Frequency Counter |
| 3. AC Voltmeter | 7. Audio Signal Generator | 11. Turntable with CD-4 PHONO cartridge |
| 4. FM Signal Generator | 8. CD-4 Signal Generator | |

AM IF & RF ALIGNMENT

Note: Remove line cord antenna from FM external antenna terminal during alignment.

Output level of signal generator should be no higher than necessary to obtain an output reading. Set SELECTOR switch S1 to AM. Signal Generator: 30% Mod.

STEP	SIGNAL GENERATOR COUPLING	SIGNAL GENERATOR FREQUENCY	RECEIVER DIAL SETTING	INDICATOR	ADJUSTMENT (Refer to Fig.5)	REMARK
1	Refer Fig. 1	455 kHz (400 Hz Mod.)	Point of interference. (on/about 600 kHz)	AC Voltmeter to TAPE OUT jack.(FRONT)	T401 (1st IFT) Both Sections T402 (2nd IFT) Both Sections	Adjust for maximum reading
2	Same as step 1	600 kHz (400 Hz Mod.)	600 kHz	Same as step 1	L401 (RF Coil) L402 (OSC Coil) L451 (Ant. Coil)	Adjust for maximum reading
3	Same as step 1	1400 kHz (400 Hz Mod.)	1400 kHz	Same as step 1	TC107 (OSC Trimmer) TC105 (ANT Trimmer) TC106 (RF Trimmer)	Adjust for maximum reading. Repeat steps 2 and 3
4	Same as step 1	1000 kHz (400 Hz Mod) Output level: 5mV/m	100 kHz	Same as step 1	VR401 (Set mechanical center) VR402	Adjust for 220 mV reading on AC Voltmeter

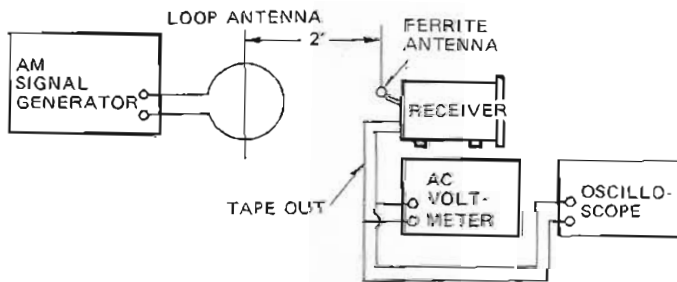
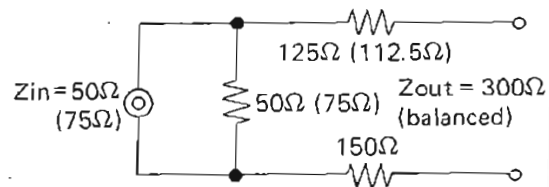

Fig. 1 AM ALIGNMENT CONNECTION



Connect FM Dummy Antenna to 300Ω antenna terminal of Receiver.

Fig. 2 FM DUMMY ANTENNA

FM RF AND IF ALIGNMENT

Note: Be sure to disconnect FM line cord antenna during alignment.

Signal generator output level should be no higher than necessary to obtain an output reading. Set Selector switch to FM. Signal Generator deviation: 75 kHz						
STEP	SIGNAL GENERATOR COUPLING	SIGNAL GENERATOR FREQUENCY	RECEIVER DIAL SETTING	INDICATOR	ADJUSTMENT (Refer to Fig.5)	REMARKS
1	Connect to FM Antenna Terminal through FM Dummy antenna (Fig. 2)	90 MHz (400 Hz, Mod)	90 MHz	AC Voltmeter connected to TAPE OUT jack (FRONT L or R)	L105 (FM OSC Coil) L101 (FM AN I Coil) L102, L103 (FM RF Coil)	Adjust for maximum reading on AC Volt meter
2	Same as step 1	106 MHz (400 Hz, Mod)	106 MHz	Same as step 1	TC104 (FM OSC Trimmer) TC101 (FM ANT Trimmer) TC102, TC103 (FM RF Trimmer)	Adjust for maximum reading
Repeat steps 1 & 2 until no further improvement is possible.						
3	Same as step 1	90 MHz (400 Hz, Mod)	90 MHz	Same as step 1	T101 (FM IFT)	Adjust for maximum reading
4	Same as step 1	Same as step 3	90 MHz	DC Voltmeter connected between BASE of TR301 and ground	T201 TOP (Discriminator)	Adjust for OV on DC Voltmeter
5	Same as step 1	Same as step 1 Signal Generator output level: 1 mV	90 MHz	Distortion Meter connected to TAPE OUT jack	T201 Bottom	Adjust for minimum distortion
6	Same as step 1	98 MHz (400 Hz, Mod)	98 MHz	DC Voltmeter connected to IC302 #5 PIN (Muting Level)	VR302	Adjust to the point where this voltage drops from about 9 volts down to 0.5V with SG output level of 3 ~ 16 μ V
7	Same as step 1	Same as step 6 Signal Generator output level: 1.0V	98 MHz	TUNING Meter	VR201	Adjust for full scale (not out of scale) on TUNING Meter

Note: European models must not be able to tune below 87.5 MHz.

MPX ALIGNMENT CONNECTION

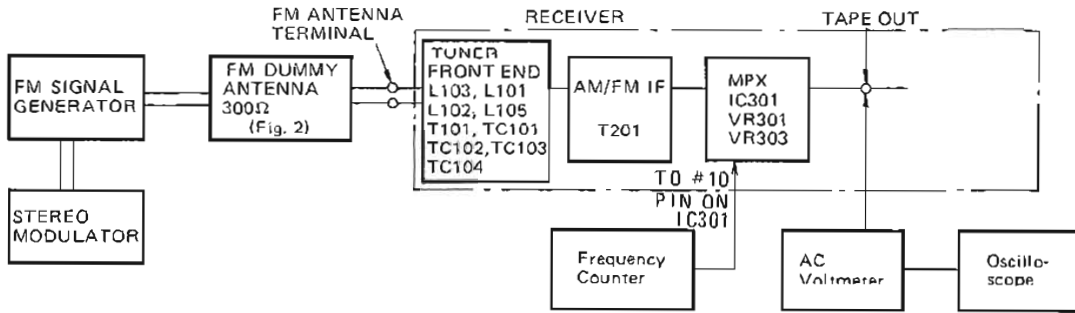

Fig. 3 MPX ALIGNMENT CONNECTION

Set SELECTOR Switch to FM tune for 98 MHz on band.
 Connect test equipment (Fig. 3).
 Signal Generator output level: 1000 μ V Deviation: 75 kHz at 100% modulation of composite signal.
 Connect FM Signal Generator to FM Antenna Terminal through FM Dummy Antenna (300 Ω).

STEP	19 kHz (PILOT SIGNAL) MODULATION Level	SIGNAL GENERATOR	OUTPUT INDICATOR	ADJUST- MENT (Refer to Fig. 5)	ADJUST FOR	NOTE
		Freq. Set to	Connected to			
1	3 ~ 4%	Stereo Modulator (Sub Signal)	Frequency counter con- nect to #10 PIN on IC301	VR303	19 kHz	
2	8%	Composite 1 kHz L channel	AC Voltmeter to TAPE OUT jack of R and L channel	VR301	R channel OUTPUT Minimum	AC Voltmeter reading should be at least 30 dB below reading at L channel
3	8%	Composite 1 kHz R channel	AC Voltmeter to TAPE OUT jack of L and R channel	VR301	L channel OUTPUT Minimum	Same as step 2. (See note)

NOTE: If you did not obtain 30 dB separation reading in step 3, readjust VR301 until you obtain 30 dB readings for both steps 2 and 3.

MAIN AMPLIFIER ALIGNMENT

INDICATOR	ADJUSTMENT	REMARKS
DC Voltmeter	VR601a, b, c, d	Adjust for 0.005V – 0.015V across R620a, b, c, d with NO SIGNAL

CD-4 DEMODULATOR ALIGNMENT

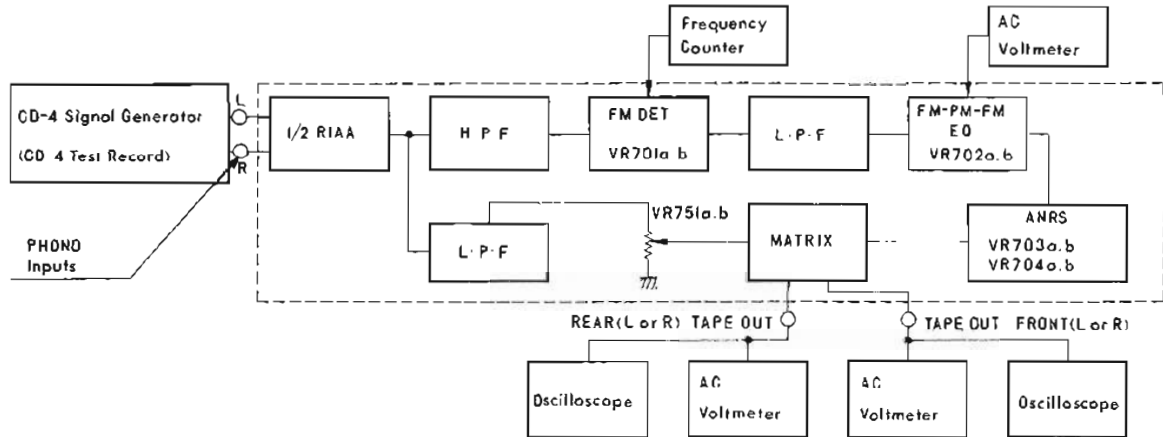

Fig. 4 DEMODULATOR ALIGNMENT CONNECTION

Set SELECTOR switch to PHONO/CD-4 and MODE switch to DISCRETE 4.
 Signal Generator output should be connected to both L and R channels (Fig. 4).
 Sub-channel output of CD-4 Signal Generator should be -52 dB (2.5 mV).
 Main channel : OFF

STEP	SIGNAL GENERATOR Freq. Set to	OUTPUT INDICATOR	ADJUST- MENT (Refer to Fig. 5)	ADJUST for	NOTE
1	Short Phono Inputs (L and R channels)	Frequency Counter connect to # 4 PIN on IC701a (b)	VR701a (b)	30 kHz	
2	1 kHz Mod., 1.3 kHz Deviation	Connect AC Volt- meter to center terminal of VR702a (b)	VR702a (b)	-12 dB (240 mV)	
3	400 Hz Mod., 0.3 kHz Deviation	Connect AC Volt- meter to TAPE OUT jacks (LEFT or RIGHT)	VR703a (b)	-31 dB (27.5 mV)	
4	10 kHz Mod., 1.68 kHz Deviation	"	VR704a (b)	-36 dB (15.5 mV)	
5	1 kHz Mod., 1.3 kHz Deviation Main channel: ON, ANRS Encoder: ON, FM-PM-FM PRE- EMPHASIS: ON	AC Voltmeter: connect to TAPE OUT jacks LEFT FRONT and LEFT REAR (RIGHT FRONT and RIGHT REAR)	VR751a (b)	Minimum LEFT REAR (RIGHT FRONT REAR)	AC Voltmeter reading should be at least 17 dB below reading at LEFT FRONT (RIGHT FRONT) channel

**ALTERNATE ALIGNMENT PROCEDURE
(Using CD-4 Test/Alignment Record)**

Set SELECTOR switch to PHONO/CD-4 and MODE switch to DISCRETE 4.
PHONO Input should be connected to both L and R channels (Refer to Fig. 4).

STEP	INPUT SIGNAL	OUTPUT INDICATOR	ADJUSTMENT (Refer to Fig. 5)	ADJUST FOR
1	Shorted PHONO inputs	Connect Frequency Counter to #4 Pin on IC701a (b)	VR701a (b)	30 kHz
2	CD-4 Test Record RG1256 Band 8	Connect AC Voltmeter to Emitter on TR706a(b)	VR702a (b)	-17 dB (140 mV)
3	Connect Audio Signal Generator to Center terminal of VR702a,b. Signal Generator set to 600 Hz and adjust output level of -27 dB (44 mV) at TR706 emitter	Connect AC Voltmeter to TAPE OUT jacks (Left or Right)	VR703a (b)	-31 dB (27.5 mV)
4	Same as Step 3 except for the frequency set to 10 kHz	Same as Step 3	VR704a (b)	-32 dB (24.5 mV)
5	CD-4 Test Record RG1256 Band 1 (or Band 3)	Connect AC Voltmeter to TAPE OUT jacks LF and LR (or RF and RR)	VR751a (b)	Minimum reading on AC Voltmeter at LEFT REAR (RIGHT REAR) Note: AC Voltmeter reading should be at least about 15 dB below reading

LEVEL DIAGRAM

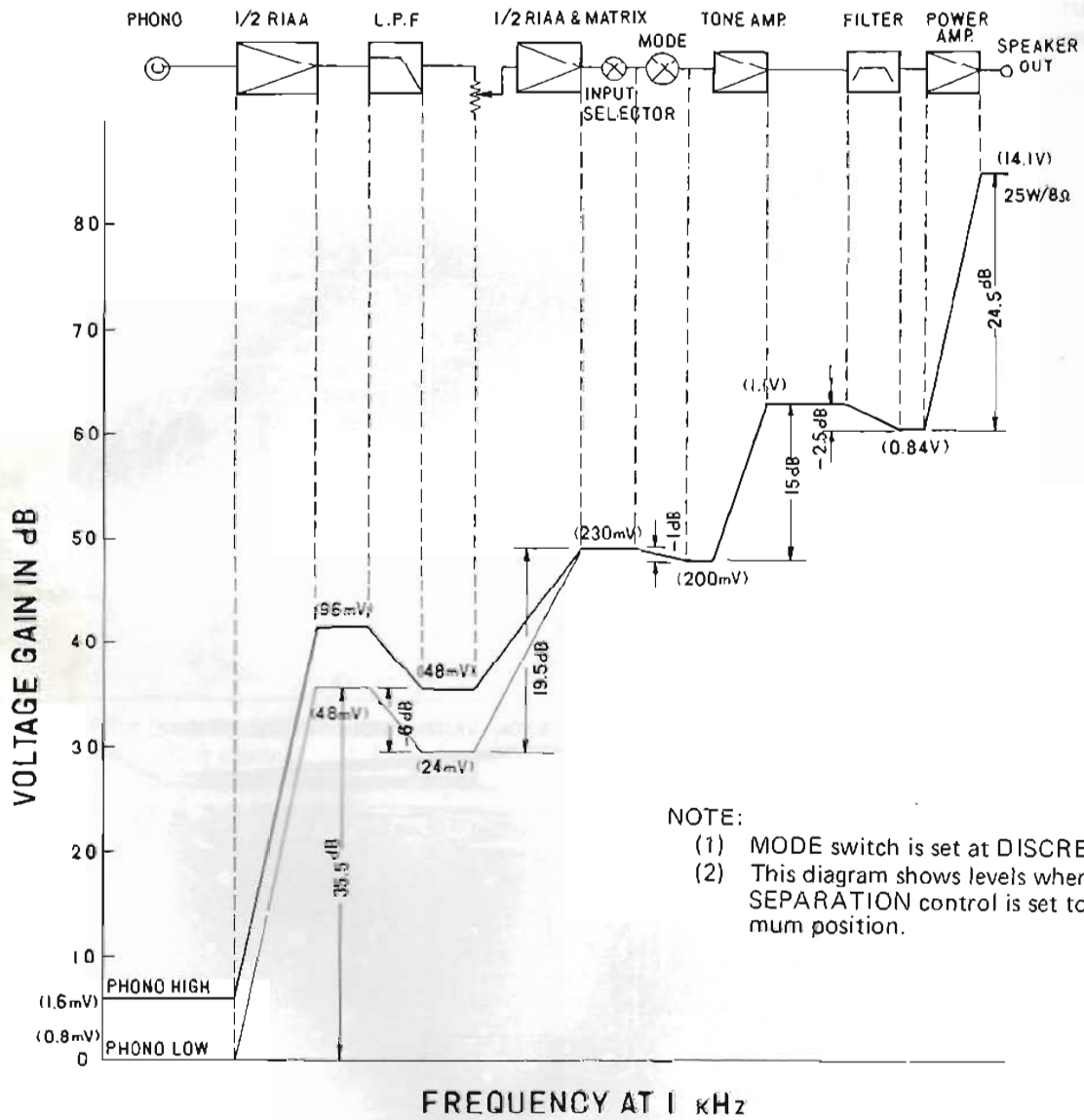
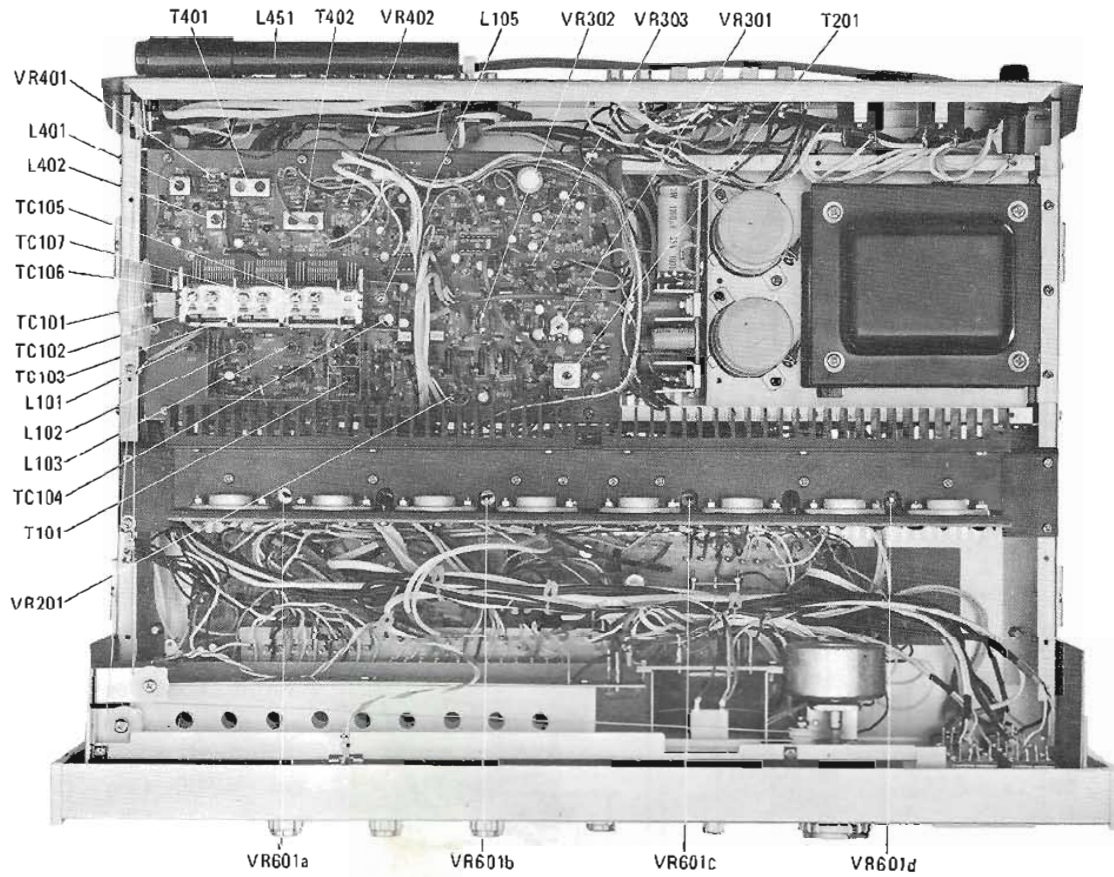
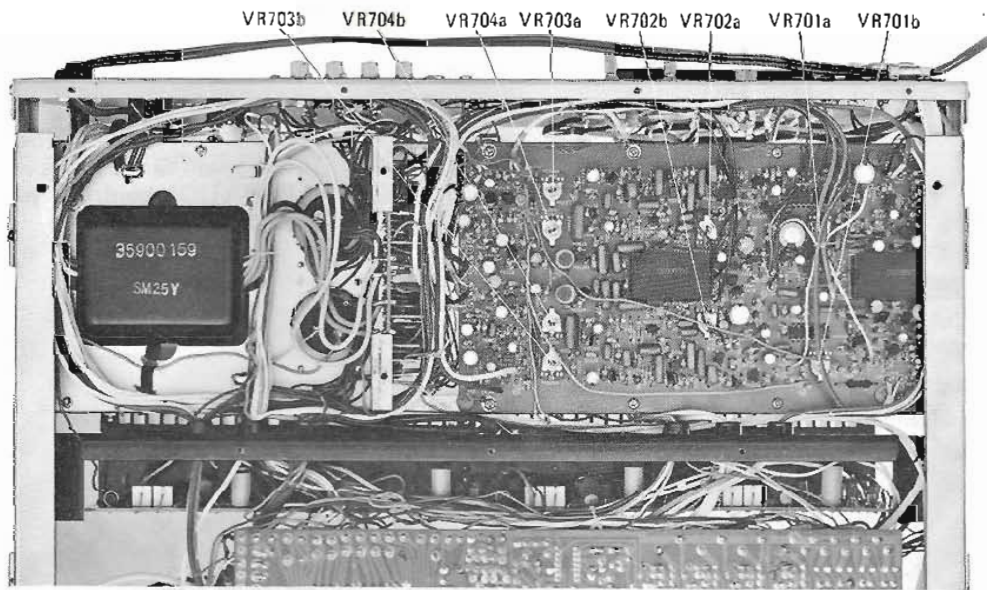

FIG. 5 ALIGNMENT POINTS



(TOP VIEW)



(BOTTOM VIEW)

TROUBLE SHOOTING

Symptom	Cause and Remedy
1) Receiver not operative: Pilot lamp does not light.	A) Faulty AC power cord. *Replace the cord. B) Defect in the power switch S12. *Replace the switch. C) Open winding in the power transformer. *Replace the transformer. D) Blown Power fuse. *Replace the fuse. E) Defective thermal protector S14. *Replace the thermal protector.
2) Fuse blows when power is turned ON.	A) Power transformer defective. *Replace the transformer. B) Short in the primary or secondary circuitry of the transformer circuitry. *Repair or replace the transformer. C) Shorted rectifier diode D806-D809. *Replace the diode. D) Short circuit in the rectifier circuit. *Repair the short. E) Shorted power transistor TR607a, b, c, d or TR608a, b, c, d or circuitry. *Replace the defective transistor and check circuit.
3) Pilot lamp does not light.	A) Defective lamp. *Replace the lamp. B) Disconnection in the transformer tertiary winding. *Replace the transformer. C) Shorted diode D810-D813. *Replace the diode.
4) Pilot lamp lights but no sound from either channel.	A) Resistor R805, R808 or R920 open. *Replace resistor. B) Capacitor C801, C802, C803, C804, C805 or C914 shorted/defective. *Replace the defective capacitor. C) Diode D801, D802, C803, D804 or D805 shorted. *Replace the diode. D) Open in secondary winding of the power transformer. *Replace the transformer. E) Transistor TR801, TR802 open. *Replace the transistor. F) Transistor TR801 shorted/open. *Replace the transistor.
5) MAIN speakers do not work.	A) Speaker switch S10 defective. *Replace the switch.
6) REMOTE speakers do not work.	A) Speaker switch S11 defective. *Replace the switch.

Symptom	Cause and Remedy
7) One channel does not work with "VOLUME" at maximum and "BALANCE" at center when a test signal is applied to the center terminal of VOLUME control VR951 of the dead channel.	<p>A) Defect in TR901, TR902 or TR903 circuitry. *Locate and correct the defect.</p> <p>B) Defect in TR603, TR604, TR605, TR601, TR602, TR606, TR607 or TR608 circuitry. *Locate and correct the defect.</p> <p>C) Interruption in copper foil of the printed circuit board 6037 or 0021. *Repair or replace it.</p> <p>D) Short in speaker output terminal. *Repair it.</p> <p>E) Open resistor R601, R605–R607, R609–R611, R613–R621, R901–R907, R917 or R918. *Replace the defective resistor.</p>
8) Same as 7 above but channel operates when test signal is applied as 7.	<p>A) Open resistor R701. *Replace the resistor.</p> <p>B) Defective selector switch S1. *Repair or replace it.</p> <p>C) Defective VOLUME VR951. *Replace the control.</p>
9) Speaker works normally but headphones do not work.	<p>A) Headphone jack defective. *Replace the jack.</p> <p>B) Open R651a (Front Left), R651d (Front Right), R651c (Rear Left), R651b (Rear Right). *Replace the resistor.</p>
10) All the inputs work normally except "AUX4" input.	<p>A) Poor contact in "AUX4" input jack. *Repair or replace the jack.</p> <p>B) Poor contact in selector switch S1. *Repair or replace the switch.</p>
11) PHONO input does not function.	<p>A) Poor contact in PHONO input jack. *Repair or replace the jack.</p> <p>B) Faulty selector switch S1. *Repair or replace the switch.</p> <p>C) Defective transistor TR701, TR702, TR711 or TR712. *Replace the transistor.</p>
12) TAPE OUT does not function.	<p>A) Defective contact in TAPE OUT output jack. *Repair or replace the jack.</p> <p>B) Resistor R701, R703–R711, R754–R756, R759–R765 open.</p> <p>C) Capacitor C701–C707, C737–C742 open/shorted. *Replace the defective capacitor.</p>
13) FM does not operate.	<p>A) Defective diode D801. *Replace the diode.</p> <p>B) Transistor TR802 damaged (OPEN). *Replace the transistor.</p> <p>C) Defective resistor R805, R808. *Replace the resistor.</p> <p>D) Short – circuit in TUNER B + circuit. *Repair the short.</p>

Symptom	Cause and Remedy
	<p>E) Poor contact in selector switch S1. *Repair or replace the switch.</p> <p>F) Resistor R303 defective. *Replace the resistor.</p> <p>G) Capacitor C301 defective. *Replace the capacitor.</p> <p>H) Defective transistor TR201, TR202 or IC IC201, IC202, IC203, IC204. *Replace the defective transistor or IC.</p> <p>I) Defective IFT T201. *Replace the IFT.</p> <p>J) Defective resistor R204, R205, R208, R210, R212, R215, R219, R220 or R301. *Replace the defective resistor.</p> <p>K) Defective capacitor C201, C212, C215. *Replace the defective capacitor.</p> <p>L) Defective transistor TR101, TR102, TR103 or coil L101, L105 of tuner board 0019. *Replace the defective component.</p> <p>M) Faulty lead-in. *Repair or replace the lead in.</p>
14) Multiplex separation not sufficient.	<p>A) Improper adjustment. *Readjust T201, VR301 and VR303. (Refer to MPX ALIGNMENT on page 11)</p> <p>B) TR301, TR302, TR303, TR304, TR305, TR306, IC301 or IC302 of TUNER Board 0019 defective. *Replace the defective component.</p> <p>C) Variable resistor VR301, VR302 or VR303 defective. *Replace the defective variable resistor.</p>
15) Stereo indicator lamp does not light.	<p>A) Defective indicator lamp PL8. *Replace the lamp.</p> <p>B) Improper adjustment of VR302 and VR303 or TUNER Board 0019. *Make readjustment. (Refer to MPX ALIGNMENT on Page 11)</p> <p>C) Defective IC IC301 or transistor TR308. *Replace the defective component.</p> <p>D) Defective diode D810, D811, D812 or D813. *Replace the defective diode.</p> <p>E) Capacitor C804 or C805 defective. *Replace the defective capacitor.</p>
16) FM volume not sufficient.	<p>A) If volume of both L and R channels not enough: Front End defective, or faulty transistor TR202, IFT T201 or diode D207, D208 of TUNER B Board 0019 or faulty C303, IC301 or IC302 of TUNER Board 0019. *Locate and replace the defective component.</p> <p>B) If sound of one channel not enough: Defective L302 (Board 0019) in case of R Channel, or defective L301 (Board 0019) in case of L channel. *Replace the defective coil.</p>

Symptom	Cause and Remedy
17) AM does not operate.	<p>A) Damaged transistor either TR401, TR402, TR403 or TR404 on TUNER Board 0019. *Replace the damaged transistor.</p> <p>B) Defective L401, L402, T401 or T402 of TUNER Board 0019. *Replace the defective component.</p> <p>C) Defective diode D401 or D402 of TUNER Board 0019. *Replace the defective diode.</p> <p>D) One of resistors of TUNER Board 0019 defective. *Replace the defective resistor.</p> <p>E) One of capacitors of TUNER Board 0019 defective. *Replace the defective capacitor.</p> <p>F) Selector switch S1 defective. *Repair or replace the switch.</p> <p>G) Defective Tuning Gang. *Replace Tuning Gang.</p> <p>H) Damaged AM bar antenna. *Repair or replace bar antenna.</p>
18) LOUDNESS has no effect.	<p>A) Defective LOUDNESS switch S7. *Replace the switch.</p> <p>B) Defective C701, C702, R702. *Replace defective component.</p> <p>C) Defective VOLUME control VR951. *Replace.</p>
19) STEREO-MONO not effective.	<p>A) Defective MODE switch S2. *Replace the switch.</p>
20) TAPE MON not effective.	<p>A) Defective TAPE MONITOR switch S4. *Replace the switch.</p> <p>B) Poor contact in TAPE MON input jacks. *Repair or replace jack.</p>
21) BASS Control has no effect.	<p>A) VR903 defective. *Replace.</p> <p>B) Defective C909, C910, R914, R915, R916 on TONE AMP Board 0021. *Replace the defective component.</p>
22) TREBLE Control has no effect.	<p>A) VR901 defective. *Replace.</p> <p>B) Defective C906, R908, R909 or R910 on TONE AMP Board 0021. *Replace the defective component.</p>
23) MID RANGE Control has no effect.	<p>A) VR902 defective. *Replace.</p> <p>B) Defective C907, C908, R911, R912 or R913 on TONE AMP Board 0021. *Replace the defective component.</p>

Symptom	Cause and Remedy
24) Excessive noise with PHONO (MAG) input.	A) Faulty TR701, TR702, TR706, TR711-TR714. *Replace the faulty transistor. B) Faulty R701-R706, C701-C705, C707 or C737. *Replace the faulty component.
25) Noisy VOLUME control.	A) Defective VR951. *Rcplace. B) Defective capacitor C901, C742, C747 or C748. *Replace the defective capacitor.
26) SIGNAL STRENGTH meter not functioning.	A) Defective meter. *Replace the meter. B) In case of FM reception, R213, VR201, C220 or C223 defective. *Replace the defective component. C) In case of AM reception, resistor R422, R423 or TR404 defective. *Replace the defective component.
27) AUTO-MAGIC AFC has no effect when AUTO-M switch is ON. (Green light behind the tuning meter does not go out when the tuning control is touched.)	A) Transistor TR701, TR702, TR703 TR704, TR705 or TR706 defective. *Replace the defective transistor. B) Resistor R701-R717 defective. *Replace the defective resistor. C) Diode D701 or D702 defective. *Replace the defective diode. D) Capacitor C701-C705 defective. *Replace the defective capacitor. F) Defective switch S5. *Replace the switch. F) Defective meter lamp PL6. *Replace the lamp.
28) Green light does not light when the tuning control is released.	A) Defective transistor TR703 (short) TR704 (open), TR705 (open). *Replace the defective transistor. B) Defective resistor R708-R717. *Replace the defective resistor. C) Defective meter lamp PL6. *Replace the lamp.
29) QUATRAVOX not effective.	A) Defective transistor TR701c, d. *Replace the defective transistor. B) Defective resistor R709c-R716c. *Replace the defective resistor. C) Defective capacitor C709c-C712c, C709d, C710d. *Replace the defective capacitor. D) Defective MODE switch S2. *Replace the switch.
30) LOW FILTER has no effect.	A) Defective switch S8. *Replace the switch. B) Defective capacitor C703e, f, g, h. *Replace the capacitor.

Symptom	Cause and Remedy
31) HIGH FILTER has no effect.	<p>A) Defective switch S9. *Replace the switch.</p> <p>B) Defective resistor R704e, f, g, h or capacitor C904e, f, g, h. *Replace the defective component.</p>
32) AUDIOROTOR has no effect.	<p>A) Defective switch S3. *Replace the switch.</p>
33) STEREO MAX does not work.	<p>A) Defective MODE switch S2. *Replace the switch.</p> <p>B) Defective transistor TR702c, d. *Replace the defective transistor.</p> <p>C) Defective resistor R718c—R722c, R718d—R722d. *Replace the defective resistor.</p> <p>D) Defective capacitor C713c, d or C714c, d. *Replace the defective capacitor.</p>
34) SQ MATRIX DECODER does not work.	<p>A) Defective MODE switch S2. *Replace the switch.</p> <p>B) Defective IC, capacitor or resistor on P.C. Board 0021. *Replace defective component.</p>
35) CD-4 Indicator Lamp does not light.	<p>A) Defective switch S1 or S2. *Replace the defective switch.</p> <p>B) Defective transistor TR703a, TR706, TR715, TR717—TR721. *Replace the defective transistor.</p> <p>C) Defective diode D701, D702, D703. *Replace the defective diode.</p> <p>D) Resistor R712a—R716a, R782—R798 or R753 open. *Replace the defective resistor.</p> <p>E) Capacitor C708a, C709a, C752—C757 short. *Replace the defective capacitor.</p>
36) CD-4 DEMODULATOR does not work. (Poor separation of Front to Back)	<p>A) Defective IC701a, b, TR703a, b—TR710a, b, TR713a, b, TR714a, b. *Replace the defective component.</p> <p>B) Defective diode D704a, b—D707a, b. *Replace the defective diode.</p> <p>C) Defective Low Pass Filter LP702. *Replace.</p> <p>D) One of resistors or capacitors on CD-4 DEMODULATOR BOARD 7100 defective. *Replace the defective component.</p> <p>E) VR701a, b—VR704a, b defective. *Replace the defective one.</p> <p>F) Defective choke coil L701a, b. *Replace the defective coil.</p>

0019 TUNER BOARD (TOP VIEW)

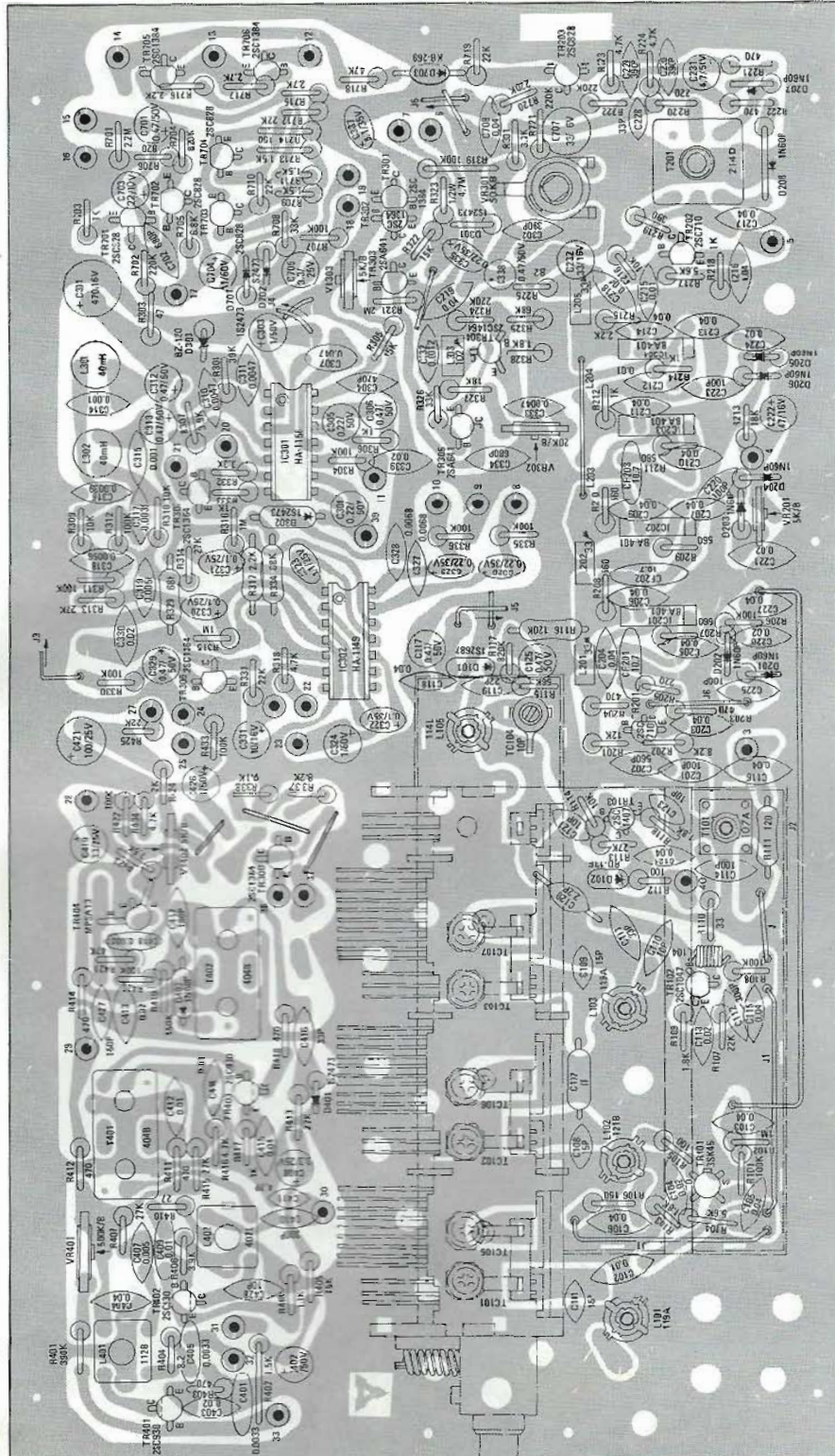

0019 TUNER BOARD (BOTTOM VIEW)

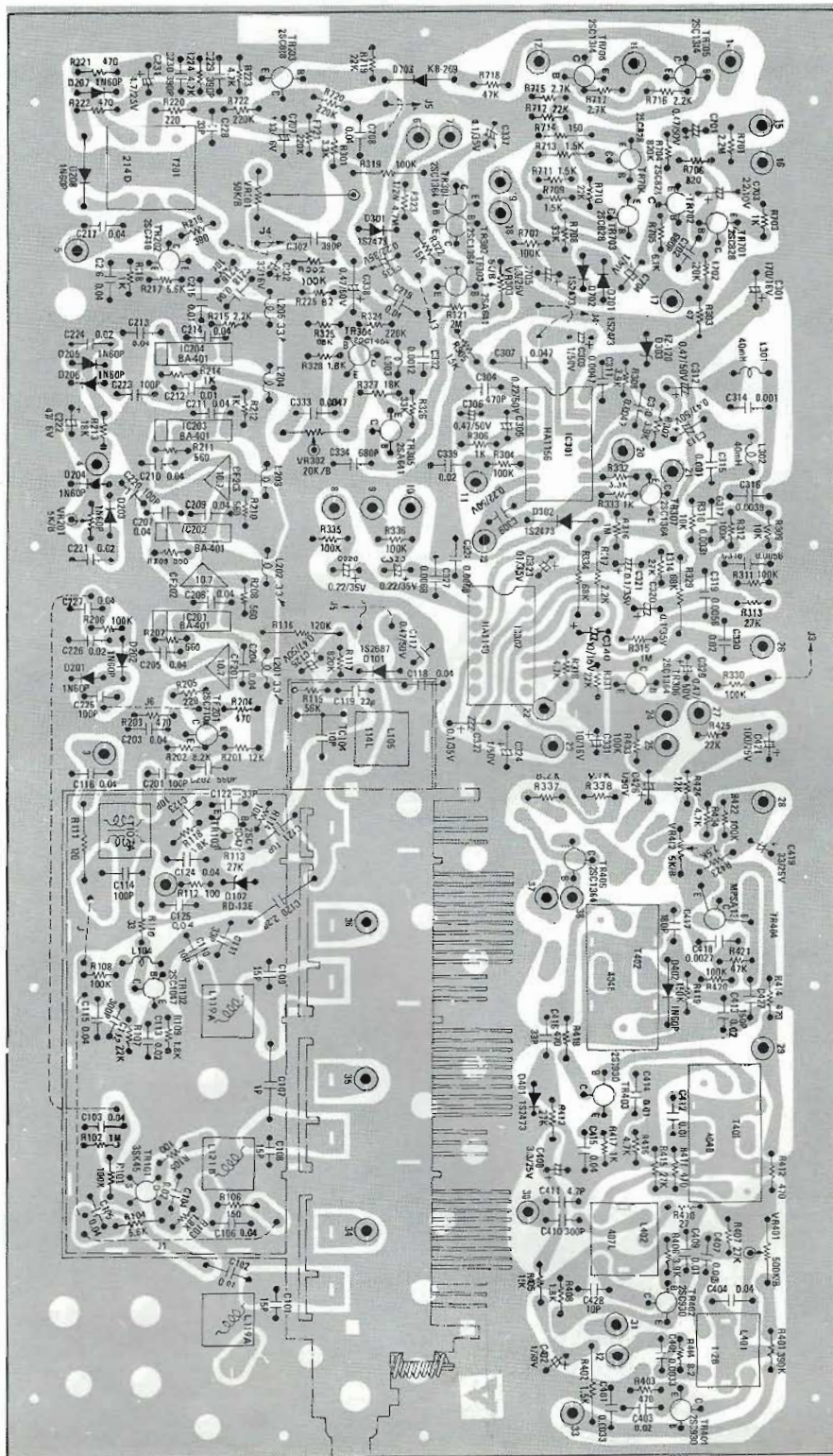

6037 MAIN AMP

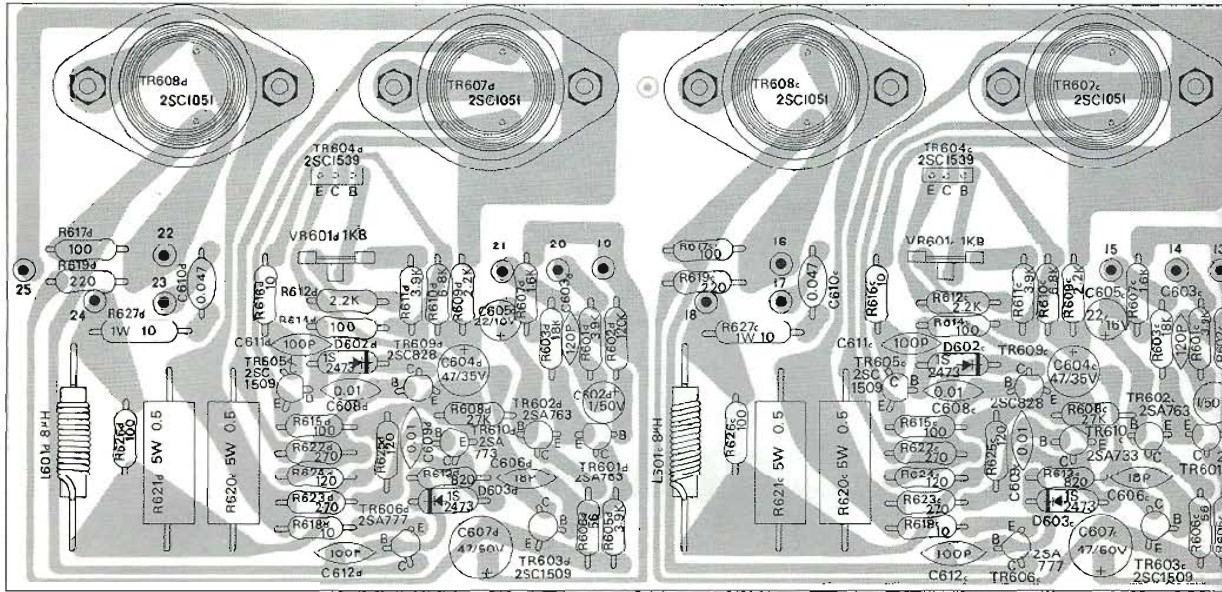

6037 MAIN AMP BO

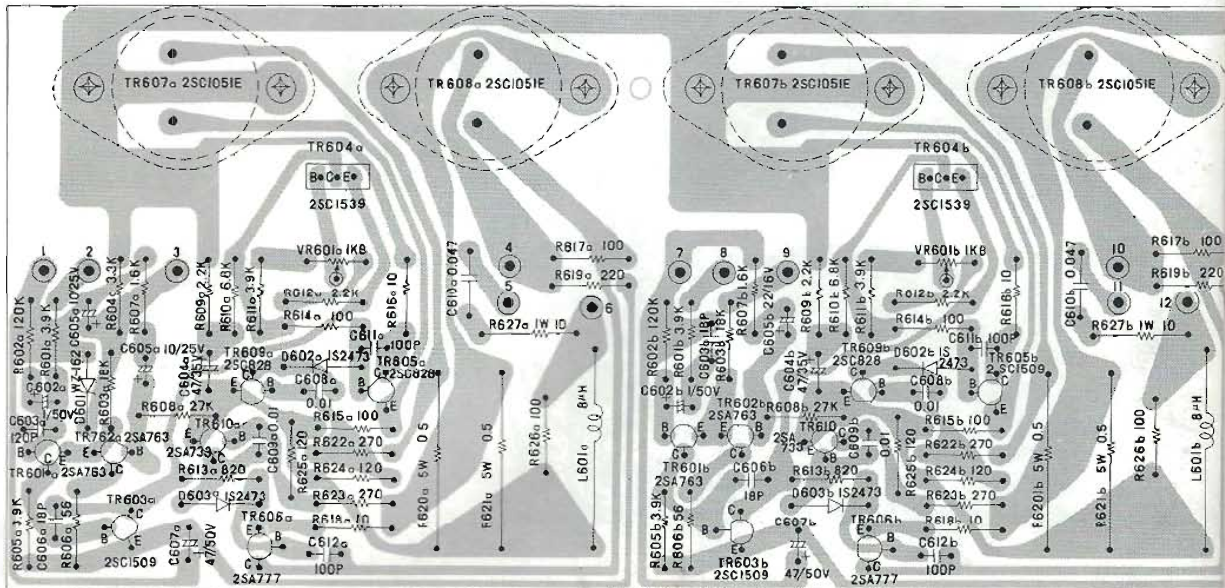

BOARD (TOP VIEW)

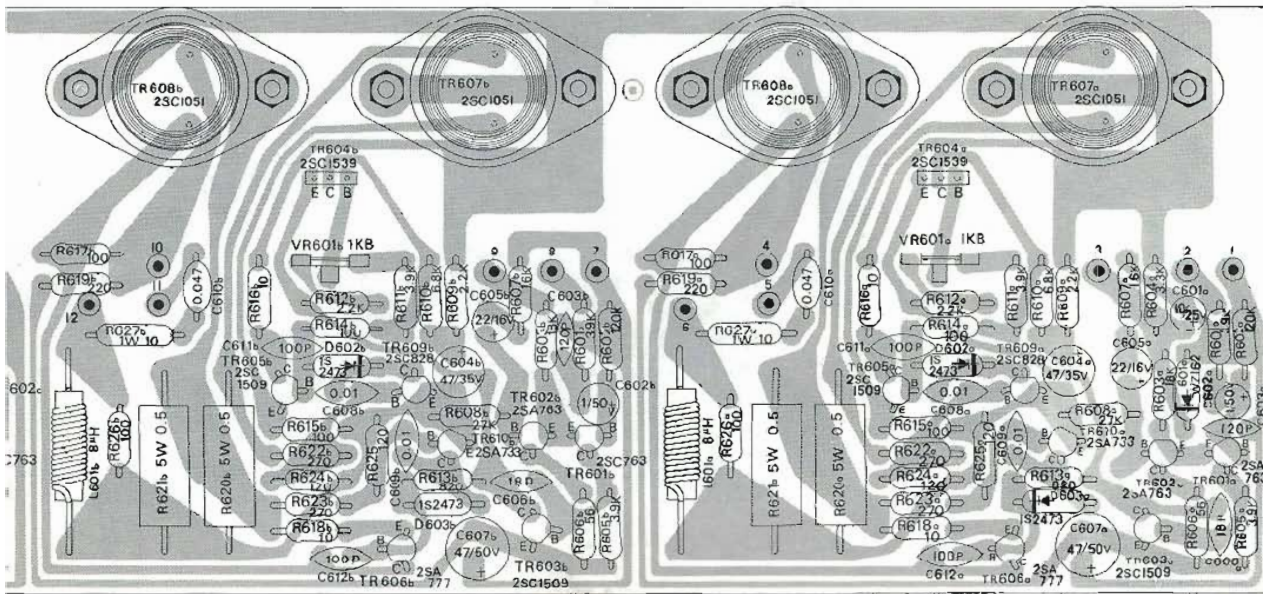

BOARD (BOTTOM VIEW)

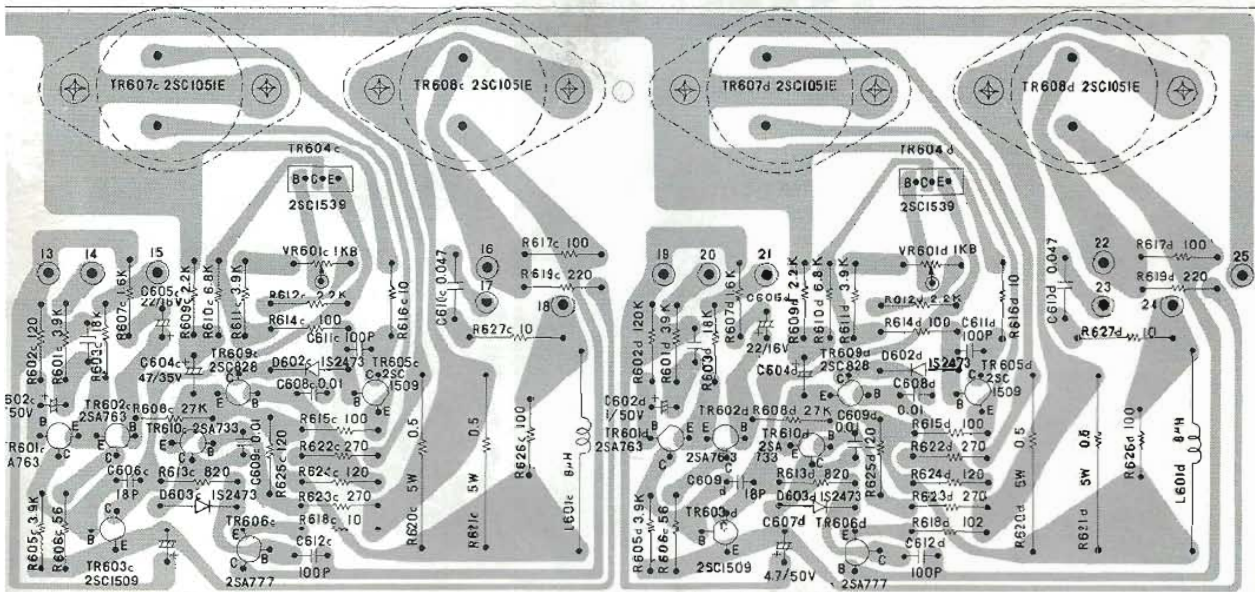

7100 CD-4 DEMODULATOR BOARD (TOP VIEW)

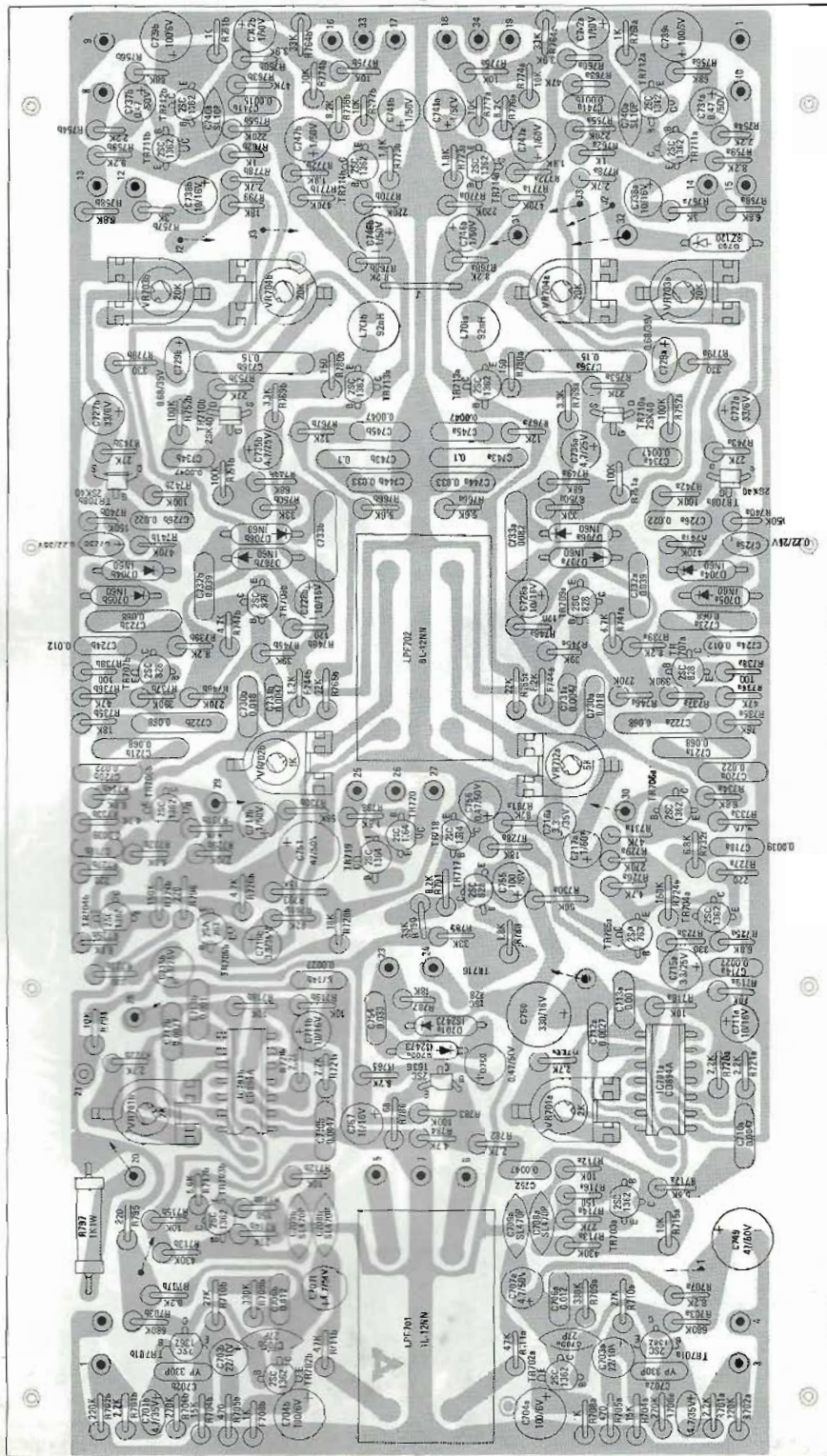

7100 CD-4 DEMODULATOR BOARD (BOTTOM VIEW)

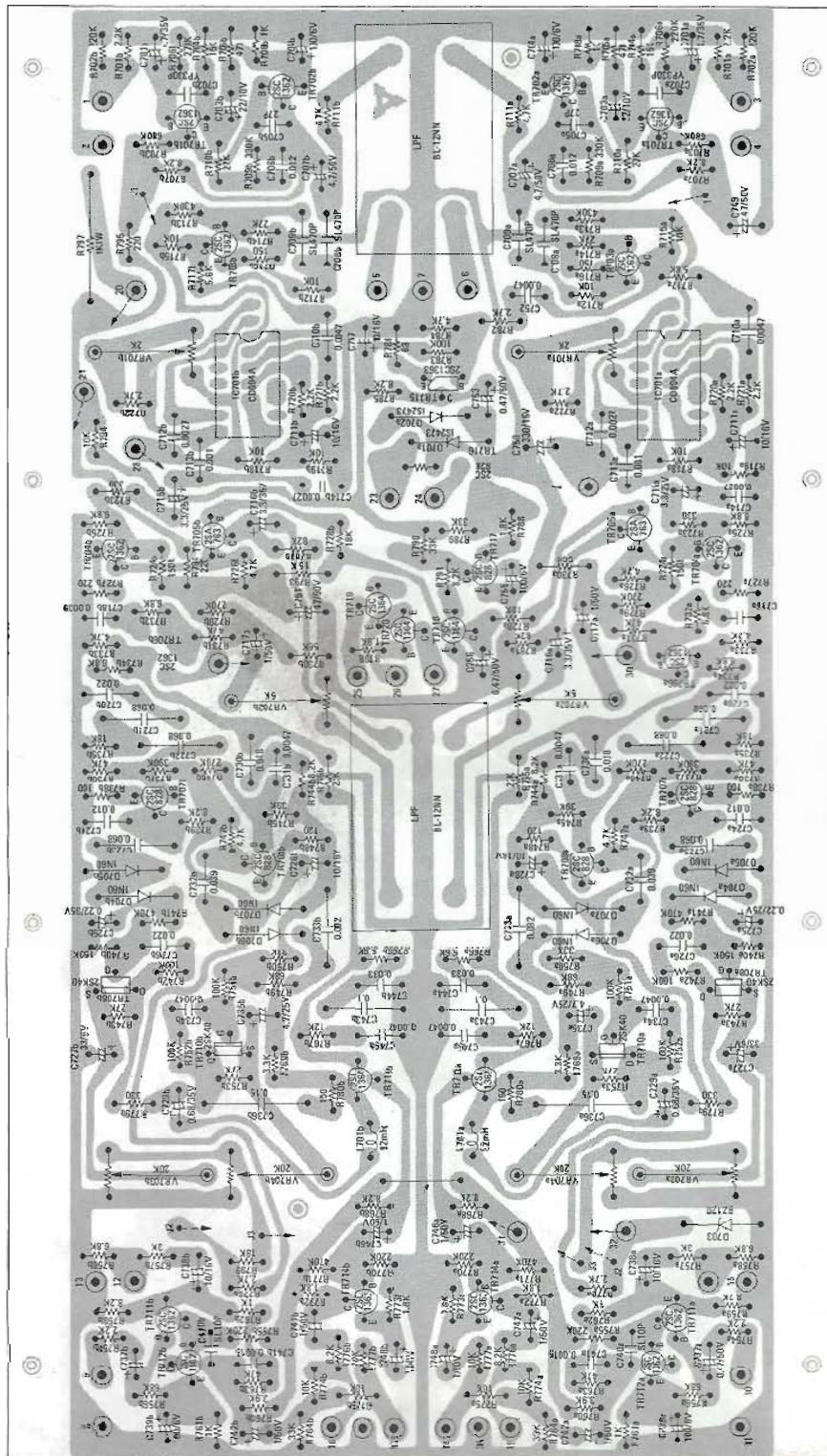

7101 SWITCH BOARD

(TOP VIEW)

(BOTTOM VIEW)

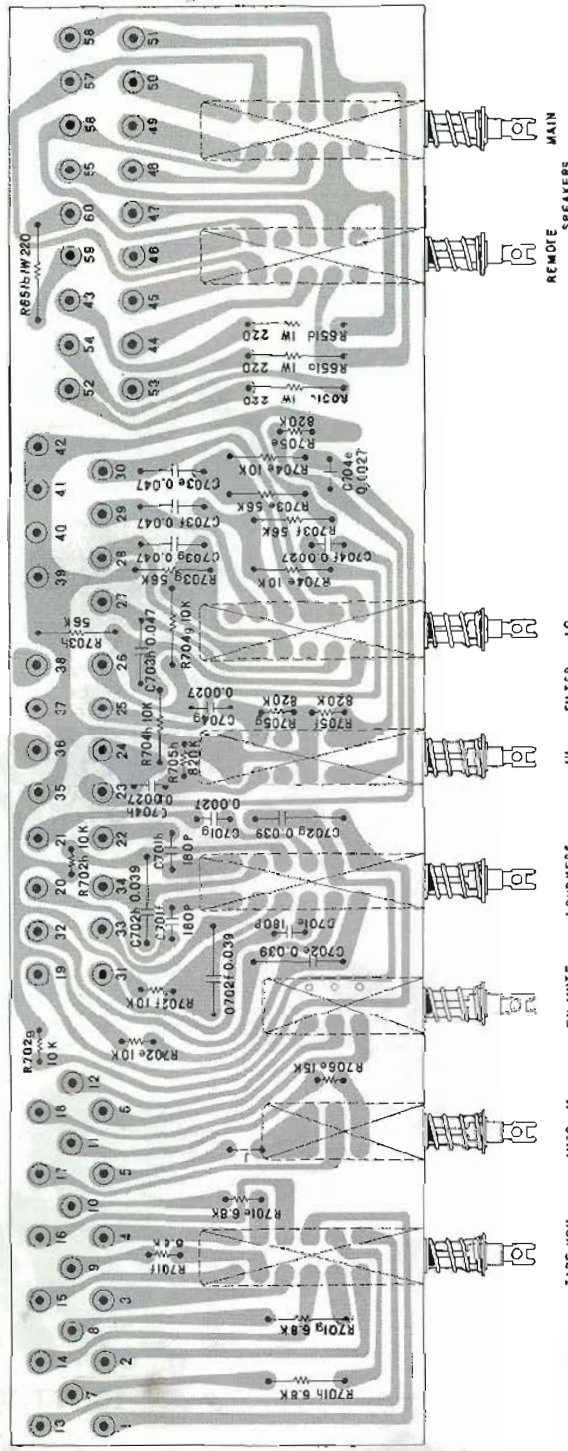
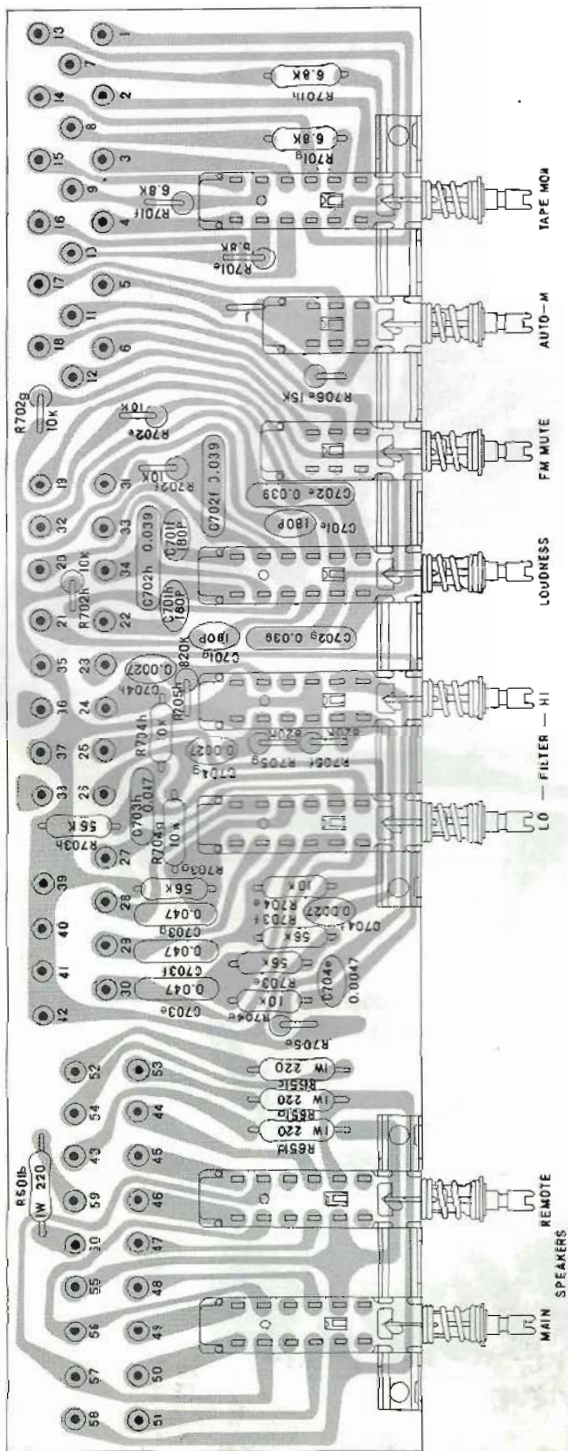

8024 POWER SUPPLY BOARD

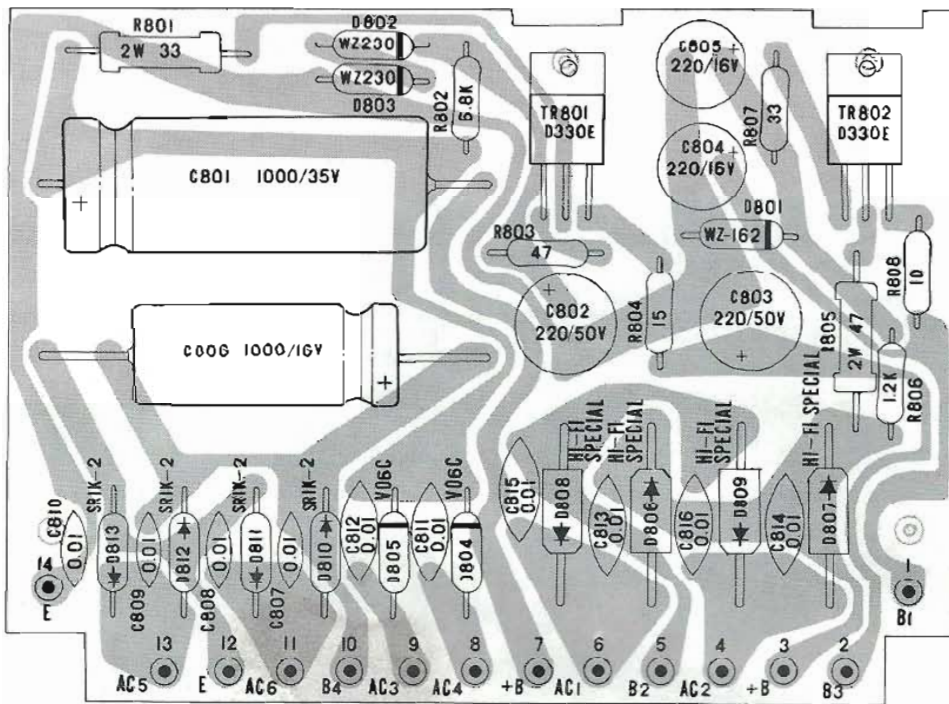

(TOP VIEW)

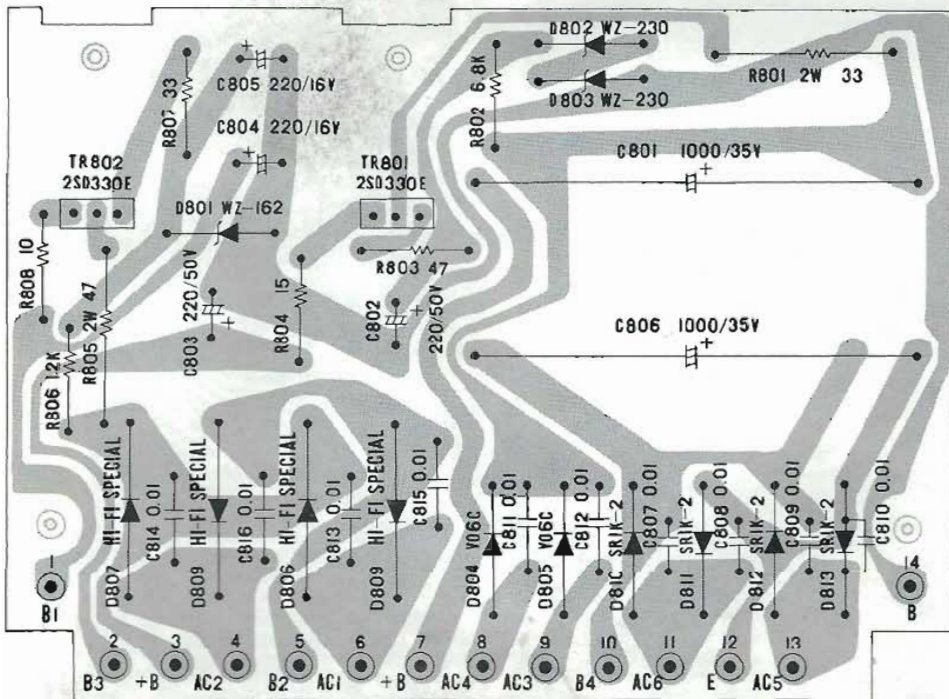

(BOTTOM VIEW)

TRANSISTOR & IC LEAD IDENTIFICATION

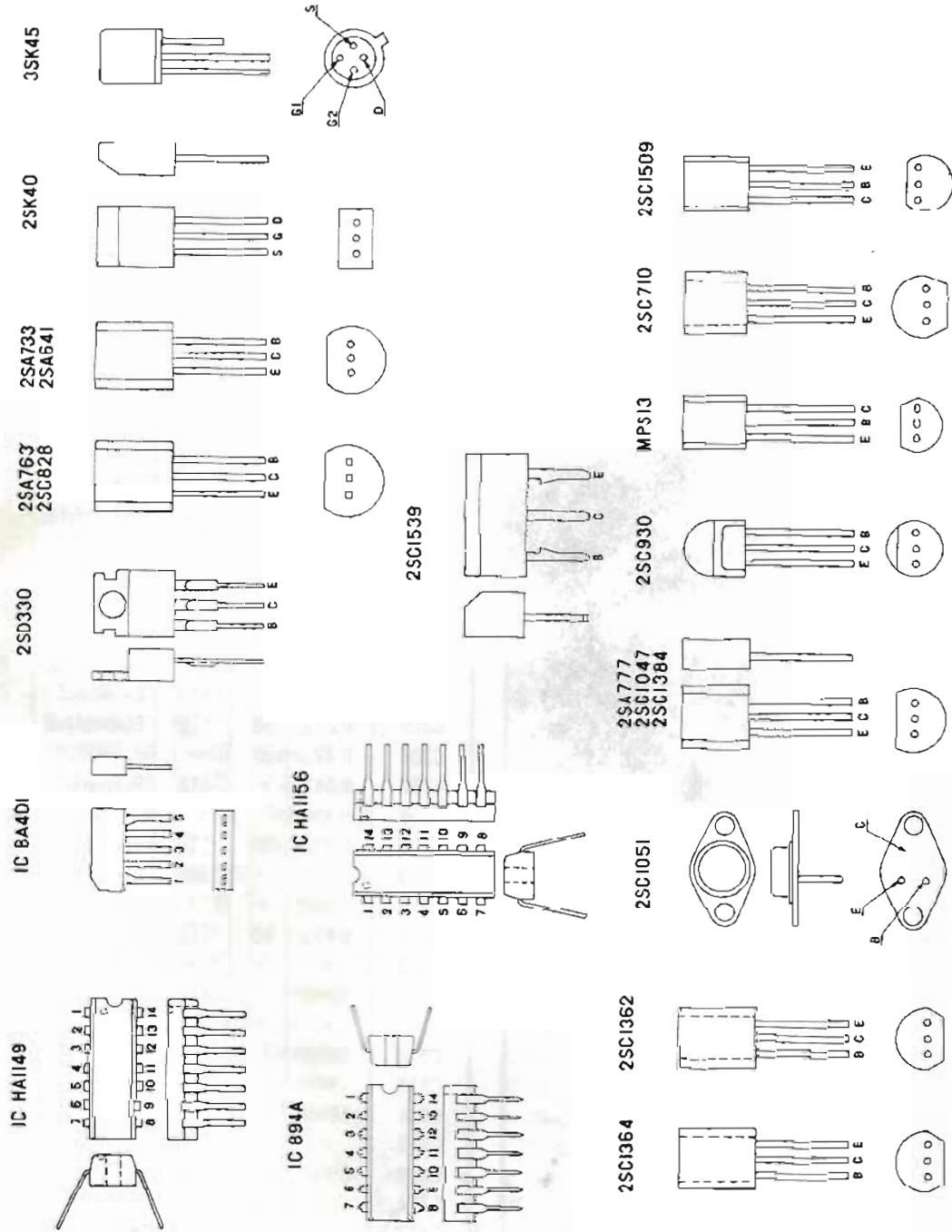

ELECTRICAL PARTS LIST

CAPACITORS					
Ref. No.	Description				R/S Part No.
	Value (F)	Voltage	Tolerance (%)	Material	
C101	15P	50	±10	Ceramic	
C102	0.01μ	25	+80 -30	"	
C103	0.04μ	"	"	"	
C104	0.02μ	"	"	"	
C105	0.04μ	"	"	"	
C106	0.04μ	"	"	"	
C107	1P	50	±10	"	
C108	15P	"	"	"	
C109	"	"	"	"	
C110	10P	"	±1PF	"	
C111	33P	"	"	"	
C112	300P	"	±10	"	
C113	0.02μ	25	+80 -30	"	
C114	100P	50	±10	"	
C115	0.04μ	25	+80 -30	"	
C116	"	"	"	"	
C117	0.47μ	50	+100 -10	Electrolytic	
C118	0.04μ	25	+80 -30	Ceramic	
C119	22P	50	±10	"	
C120	2.2P	50	±1PF	"	
C121	10P	50	±1PF	"	
C122	33P	"	±10	"	
C123	10P	"	±1PF	"	
C124	0.04μ	25	+80 -30	"	
C125	0.47μ	50	+75 -10	Electrolytic	
C126	0.04μ	25	+80 -30	Ceramic	
C127	"	"	"	"	
C201	100P	50	±10	"	
C202	560P	"	"	"	
C203	0.04μ	25	+80 -30	"	
C204	0.04μ	25	"	"	
C205	"	"	"	"	
C206	"	"	"	"	
C207	"	"	"	"	
C208	Not Used				
C209	0.04μ	25	+80 -30	Ceramic	
C210	"	"	"	"	
C211	"	"	"	"	
C212	0.01μ	"	"	"	
C213	0.04μ	"	"	"	
C214	0.04μ	25	+80 -30	"	

Ref. No.	Description				R/S Part No.
	Value (F)	Voltage	Tolerance (%)	Material	
C215	0.01μ	25	+80 -30	Ceramic	
C216	0.04μ	"	"	"	
C217	"	"	"	"	
C218	"	"	"	"	
C219	"	"	"	"	
C220	100P	50	±10	"	
C221	0.02μ	25	+80 -30	"	
C222	47μ	6	+100 -10	Electrolytic	
C223	100P	50	±10	Ceramic	
C224	0.02μ	25	+80 -30	"	
C225	100P	50	±10	"	
C226	0.02μ	25	+80 -30	"	
C227	0.04μ	"	"	"	
C228	33P	50	±10	"	
C229	390P	50	±10	"	
C230	"	"	"	"	
C231	4.7μ	25	+75 -10	Electrolytic	
C232	33μ	16	+100 -10	"	
C233	0.04μ	25	+80 -30	Ceramic	
C301	470μ	16	+100 -10	Electrolytic	
C302	390P	50	±10	Ceramic	
C303	1μ	"	+75 -10	Electrolytic	
C304	470P	"	±10	Ceramic	
C305	0.22μ	50	+100 -10	Electrolytic	
C306	0.47μ	50	"	"	
C307	0.047μ	"	±10	Polyester	
C308	Not Used				
C309	0.22μ	50	+100 -10	Electrolytic	
C310	4700P	"	±10	Ceramic	
C311	4700P	"	"	"	
C312	0.47μ	50	+75 -10	Electrolytic	
C313	"	"	"	"	
C314	1000P	"	±10	Ceramic	
C315	"	"	"	"	
C316	3900P	"	"	"	
C317	"	"	"	"	
C318	5600P	"	"	"	
C319	"	"	"	"	
C320	0.1μ	35	±20	Tantalum	
C321	"	"	"	"	
C322	"	"	"	"	

Ref. No.	Description				R/S Part No.
	Value (F)	Voltage	Tolerance (%)	Material	
C323	0.1 μ	35	± 20	Tantalum	
C324	1 μ	50	$\begin{smallmatrix} +75 \\ -10 \end{smallmatrix}$	Electrolytic	
C325	0.22 μ	35	± 20	Tantalum	
C326	"	"	"	"	
C327	6800P	50	± 10	Ceramic	
C328	"	"	"	"	
C329	0.47 μ	50	$\begin{smallmatrix} +75 \\ -10 \end{smallmatrix}$	Electrolytic	
C330	0.02 μ	25	$\begin{smallmatrix} +80 \\ -30 \end{smallmatrix}$	Ceramic	
C331	10 μ	16	$\begin{smallmatrix} +50 \\ -10 \end{smallmatrix}$	Electrolytic	
C332	1000P	50	± 10	Ceramic	
C333	4700P	"	"	"	
C334	680P	"	"	"	
C335	0.22 μ	35	± 20	Tantalum	
C336	Not Used				
C337	0.1 μ	35	± 20	Tantalum	
C338	0.17 μ	50	$\begin{smallmatrix} +75 \\ -10 \end{smallmatrix}$	Electrolytic	
C339	0.02 μ	25	$\begin{smallmatrix} +80 \\ -30 \end{smallmatrix}$	Ceramic	
C340	10 μ	16	$\begin{smallmatrix} +50 \\ -10 \end{smallmatrix}$	Electrolytic	
C341	1 μ	50	$\begin{smallmatrix} +75 \\ -10 \end{smallmatrix}$	"	
C351	0.01 μ	25	$\begin{smallmatrix} +80 \\ -30 \end{smallmatrix}$	Ceramic	
C410	3300P	50	± 10	Polyester	
C402	1 μ	"	$\begin{smallmatrix} +75 \\ -10 \end{smallmatrix}$	Electrolytic	
C403	0.02 μ	25	$\begin{smallmatrix} +80 \\ -30 \end{smallmatrix}$	Ceramic	
C404	0.04 μ	"	"	"	
C405	3300P	50	± 10	Polyester	
C406	Not Used				
C407	5000P	50	± 10	Ceramic	
C408	3.3 μ	25	$\begin{smallmatrix} +75 \\ -10 \end{smallmatrix}$	Electrolytic	
C409	0.01 μ	50	± 10	Polyester	
C410	300P	"	"	Ceramic	
C411	4.7P	"	$\pm 0.5PF$	"	
C412	0.01 μ	25	$\begin{smallmatrix} +80 \\ -30 \end{smallmatrix}$	"	
C413	0.02 μ	"	"	"	
C414	0.01 μ	"	"	"	
C415	0.04 μ	"	"	"	
C416	33P	50	± 10	"	
C417	180P	50	± 10	Ceramic	
C418	2700P	"	"	Polyester	
C419	3.3 μ	25	"	Electrolytic	
C420	Not Used				
C421	100 μ	25	$\begin{smallmatrix} +50 \\ -10 \end{smallmatrix}$	Electrolytic	

Ref. No.	Description				R/S Part No.
	Value (F)	Voltage	Tolerance (%)	Material	
C422	Not Used				
C423	"				
C424	"				
C425	"				
C426	1 μ	50	$\begin{smallmatrix} +75 \\ -10 \end{smallmatrix}$	Electrolytic	
C427	150P	"	± 10	Ceramic	
C428	10P	"	"	"	
C551a,b	2200P	"	"	"	
C601	10 μ	25	$\begin{smallmatrix} +50 \\ -10 \end{smallmatrix}$	Electrolytic	
C602a,b,c,d	1 μ	50	$\begin{smallmatrix} +75 \\ -10 \end{smallmatrix}$	"	
C603a,b,c,d	120P	"	± 10	Ceramic	
C604a,b,c,d	47 μ	35	$\begin{smallmatrix} +50 \\ -10 \end{smallmatrix}$	Electrolytic	
C605a,b,c,d	22 μ	16	"	"	
C606a,b,c,d	18P	50	± 10	Ceramic	
C607a,b,c,d	47 μ	"	$\begin{smallmatrix} +50 \\ -10 \end{smallmatrix}$	Electrolytic	
C608a,b,c,d	0.01 μ	"	± 10	Ceramic	
C609a,b,c,d	"	"	"	"	
C610a,b,c,d	0.047 μ	"	"	Polyester	
C611a,b,c,d	100P	"	"	Ceramic	
C612a,b,c,d	"	"	"	"	
C651	0.04 μ	"	"	"	
C701	0.47 μ	50	$\begin{smallmatrix} +75 \\ -10 \end{smallmatrix}$	Electrolytic	
C701a,b	4.7 μ	35	± 20	Tantalum	
C701c,d	0.1 μ	"	"	"	
C701e,f,g,h	180P	50	± 10	Ceramic	
C702	680P	"	"	"	
C702a,b	330P	"	"	"	
C702c,d	8200P	50	± 10	Polyester	
C702e,f,g,h	0.039 μ	"	"	"	
C703	10 μ	16	$\begin{smallmatrix} +50 \\ -10 \end{smallmatrix}$	Electrolytic	
C703a,b	22 μ	10	"	"	
C703c,d	0.039 μ	50	± 10	Polyester	
C703e,f,g,h	0.047 μ	"	"	"	
C704	1 μ	"	$\begin{smallmatrix} +75 \\ -10 \end{smallmatrix}$	Electrolytic	
C704a,b	100 μ	6	$\begin{smallmatrix} +50 \\ -10 \end{smallmatrix}$	"	
C704c,d	0.056 μ	50	± 10	Polyester	
C704e,f,g,h	2700P	"	"	"	
C705	3.3 μ	25	$\begin{smallmatrix} +75 \\ -10 \end{smallmatrix}$	Electrolytic	
C705a,b	27P	50	± 10	Ceramic	
C705c,d	0.22 μ	35	± 20	Tantalum	
C706a,b	0.012 μ	50	± 10	Polyester	

Ref. No.	Description				R/S Part No.
	Value (F)	Voltage	Tolerance (%)	Material	
C706c,d	1 μ	50	+75 -10	Electrolytic	
C707	33 μ	6	+50 -10	"	
C707a,b	4.7 μ	50	"	"	
C707c,d	1 μ	"	"	"	
C708	0.04 μ	"	+80 -30	"	
C708a,b	470P	"	± 10	Ceramic	
C708c	220 μ	35	+50 -10	Electrolytic	
C709a,b	470P	50	± 10	Ceramic	
C709c,d	1 μ	"	+75 -10	Electrolytic	
C710a,b	4700P	"	± 10	Polyester	
C710c,d	"	"	+75 -10	Electrolytic	
C711a,b	10 μ	16	+50 -10	"	
C711c	2200P	50	± 10	Polyester	
C712a,b	2700P	"	"	"	
C712c	47 μ	16	+50 -10	Electrolytic	
C713a,b	1000P	50	± 10	Polyester	
C713c,d	1 μ	"	+75 -10	Electrolytic	
C714a,b	2700P	"	± 10	Polyester	
C714c,d	1 μ	"	+75 -10	Electrolytic	
C715a,b	3.3 μ	25	"	"	
C716a,b	3.3 μ	35	"	"	
C717a,b	1 μ	50	"	"	
C718a,b	3900P	"	± 10	Polyester	
C719a,b	Not Used				
C720a,b	0.022 μ	50	+10	Polyester	
C721a,b	0.068 μ	"	"	"	
C722a,b	"	"	"	"	
C723a,b	"	"	"	"	
C724a,b	0.012 μ	"	"	"	
C725a,b	0.22 μ	35	± 20	Tantalum	
C726a,b	0.022 μ	50	± 10	Polyester	
C727a,b	33 μ	6	+50 -10	Electrolytic	
C728a,b	10 μ	16	"	"	
C729a,b	0.68 μ	35	± 20	Tantalum	
C730a,b	0.018 μ	50	± 10	Polyester	
C731a,b	4700P	"	"	"	
C732a,b	0.039 μ	"	"	"	
C733a,b	0.082 μ	"	"	"	
C734a,h	4700P	"	"	"	
C735a,b	4.7 μ	25	+75 -10	Electrolytic	
C736a,b	0.15 μ	50	± 10	Polyester	

Ref. No.	Description				R/S Part No.
	Value (F)	Voltage	Tolerance (%)	Material	
C737a,b	0.47 μ	50	+75 -10	Electrolytic	
C738a,b	10 μ	16	+50 -10	"	
C739a,b	100 μ	6	"	"	
C740a,b	10P	50	± 10	Ceramic	
C741a,b	1500P	"	"	Polyester	
C742a,b	4.7 μ	35	+75 -10	Electrolytic	
C743a,b	0.1 μ	50	± 10	Polyester	
C744a,b	0.033 μ	"	"	"	
C745a,b	4700P	"	"	"	
C746a,b	1 μ	"	+75 -10	Electrolytic	
C747a,b	4.7 μ	35	"	"	
C748a,b	"	"	"	"	
C749	47 μ	50	+50 -10	"	
C750	330 μ	16	"	Electrolytic	
C751	47 μ	50	"	"	
C752	4700P	"	± 10	Polyester	
C753	0.47 μ	"	+75 -10	Electrolytic	
C754	0.033 μ	"	± 10	Polyester	
C755	100 μ	6	+50 -10	Electrolytic	
C756	0.47 μ	50	+75 -10	"	
C757	10 μ	16	+50 -10	"	
C758	0.01 μ	25	+80 -30	Ceramic	
C759a,b	"	"	"	"	
C760a,b	"	"	"	"	
C761a,b	"	"	"	"	
C762	41 μ	50	+50 -10	Electrolytic	
C763	1000 μ	16	"	"	
C764a,b	0.47 μ	50	+75 -10	"	
C765a,b	"	"	"	"	
C766	0.01 μ	50	± 10	Ceramic	
C801	1000 μ	35	"	"	
C802	220 μ	50	"	"	
C803	"	"	"	"	
C804	16 μ	"	"	"	
C805	"	"	"	"	
C806	2,200 μ	10	"	"	
C807	0.01 μ	50	± 10	Ceramic	
C808	"	"	"	"	
C809	"	"	"	"	
C810	"	"	"	"	
C811	"	500	"	"	

Ref. No.	Description				/RS Part No.
	Value (F)	Voltage	Tolerance (%)	Material	
C812	0.01 μ	500	± 10	Ceramic	
C813	"	"	"	"	
C814	"	"	"	"	
C815	"	"	"	"	
C816	"	"	"	"	
C851	8000 μ	50	± 50 -10	Electrolytic	
C852	"	"	"	"	
C853	4700P	250 AC	± 20	Polyester	
C854	"	"	"	"	
C901a,b,c,d	0.47 μ	50	$+75$ -10	Electrolytic	
C902a,b,c,d	100P	"	± 10	Ceramic	
C903a,b,c,d	330P	"	"	"	
C904a,b,c,d	1 μ	"	$+75$ -10	Electrolytic	
C905a,b,c,d	180P	"	± 10	Ceramic	
C906a,b,c,d	1500P	50	"	Polyester	
C907a,b,c,d	5600P	"	"	"	
C908a,b,c,d	"	"	"	"	
C909a,b,c,d	0.039 μ	"	"	"	
C910a,b,c,d	"	"	"	"	
C911a,b,c,d	1 μ	"	$+75$ -10	Electrolytic	
C912a,b,c,d	33P	"	± 10	Ceramic	
C913a,b,c,d	4.7 μ	35	$+75$ -10	Electrolytic	
C914	100 μ	50	$+50$ -10	"	

CERAMIC FILTERS

Ref. No.	Description	R/S Part No.	Part No.
CF-201	SFE 10.7MA 8	C-0546	35300012
CF-202	"	"	"
CF-203	"	"	"

DIODES				
Ref. No.	Type No.	R/S Part No.	Part No.	Manufacturer
D101	1S2687		30600560	JRC
D102	RD-13		30600331	NEC
D201	1N60P		30600011	UNISON
D202	"		"	"
D203	"		"	"
D204	"		"	"
D205	"		"	"
D206	"		"	"
D207	"		"	"
D208	"		"	"
D209	"		"	"
D301	1S2473		30600410	Toyo Electronics
D302	"		"	"
D303	BZ-120		30600440	JRC
D401	1S2473		30600410	Toyo Electronics
D402	1N60P		30600011	UNISON
D601	WZ-162		30600320	JRC
D602a,b,c,d	1S2473		30600410	Toyo Electronics
D603a,b,c,d	"		"	"
D701	1S2473		30600410	Toyo Electronic
D703	KB-269		30600490	UNISON
D701a	1S2473		30600410	Toyo Electronics
D702a	"		"	"
D703a	BZ-120		30600440	JRC
D704a,b	1N60		30600010	UNISON
D705a,b	"		"	"
D706a,b	"		"	"
D707a,b	"		"	"
D801	WZ-162		30600320	JRC
D802	WZ-230		30600600	"
D803	"		"	"
D804	VO6C		30600030	Hitachi
D805	VO6C		30600030	Hitachi
D806	HIFI SPECIAL		30600520	General Instrument of Taiwan
D807	"		"	"
D808	"		"	"
D809	"		"	"
D810	SR1K-2		30600540	"
D811	"		"	"
D812	"		"	"
D813	"		"	"

INTEGRATED CIRCUITS						
Ref. No.	Type No.	R/S Part No.	Part No.	Manufacturer	Type No.	Manufacturer
IC201	BA-401		30900230	Toyo Electronics	TA7060	Toshiba
IC202	"		"	"	"	"
IC203	"		"	"	"	"
IC204	"		"	"	"	"
IC301	HA-1156		30900260	Hitachi	SN76115	Texas
IC302	HA-1149		30900270	"	"	"
IC701	MC1312P		30900190	Motorola	"	"
IC701a,b	CD894A		30900280	Signetics	"	"

LAMPS

Ref. No.	Description	R/S Part No.	Mfr's Part No.
PL1	8V, 250mA	L-0503	37008019
PL2	"	"	"
PL3	"	"	"
PL4	"	"	"
PL5	"	"	"
PL6	"	"	"
PL7	"	"	"
PL8	6V, 65mA (Dial Pointer)	D-1141	25034001
PL9	6V, 65mA (Dial Pointer)	"	"
PL10	8V, 30mA	L-0349	37008001
PL11	8V, 30mA	"	37008001

PRINTED CIRCUIT BOARDS

Ref. No.	Description	R/S Part No.	Mfr's Part No.
0019	TUNER	X-4867	96001920
0021	SQ & TONE CONTROL	X-4869	96002120
6037	MAIN AMP	X-2128	96603710
7088	AUTOMATIC LAMP		96708820
7099	DIAL LAMP		96709910
7100	CD-4 DEMODULATOR	X-4868	96710010
7101	SWITCH	X-5010	96710120
8024	POWER SUPPLY	X-4870	96802410

RESISTORS

Ref. No.	Description				R/S Part No.
	Value (ohm)	Wattage	Tolerance (%)	Material	
R101	100K	1/4	±5	Carbon	
R102	1M	"	"	"	
R103	1.8K	"	"	"	
R104	5.6K	"	"	"	
R105	100	"	"	"	
R106	150	"	"	"	
R107	22K	"	"	"	
R108	100K	"	"	"	
R109	1.8K	"	"	"	
R110	33	"	"	"	
R111	120	"	"	"	
R112	100	"	"	"	
R113	27K	"	"	"	
R114	10K	"	"	"	
R115	56K	"	"	"	
R116	120K	"	"	"	
R117	820K	"	"	"	
R118	1.8K	"	"	"	
R201	12K	"	"	"	
R202	8.2K	"	"	"	
R203	470	"	"	"	
R204	"	"	"	"	
R205	220	"	"	"	
R206	100K	"	"	"	
R207	560	"	"	"	
R208	"	"	"	"	
R209	"	"	"	"	
R210	"	"	"	"	
R211	"	"	"	"	
R212	1K	"	"	"	
R213	18K	"	"	"	
R214	1K	"	"	"	
R215	2.2K	"	"	"	
R216	10K	"	"	"	
R217	5.6K	"	"	"	
R218	1K	"	"	"	
R219	390	"	"	"	
R220	220	"	"	"	
R221	470	"	"	"	
R222	"	"	"	"	
R223	4.7K	"	"	"	
R224	"	"	"	"	
R225	82	"	"	"	

Ref. No.	Description				R/S Part No.
	Value (ohm)	Watt-age	Tolerance (%)	Material	
R226	22K	1/4	±5	Carbon	
R227	1K	"	"	"	
R228	470	"	"	"	
R301	3.3K	"	"	"	
R302	100K	"	"	"	
R303	47	"	"	"	
R304	100K	"	"	"	
R305	15K	"	"	"	
R306	1K	"	"	"	
R307	3.9K	"	"	"	
R308	"	"	"	"	
R309	10K	"	"	"	
R310	"	"	"	"	
R311	100K	"	"	"	
R312	"	"	"	"	
R313	27K	"	"	"	
R314	"	"	"	"	
R315	1M	"	"	"	
R316	"	"	"	"	
R317	2.2K	"	"	"	
R318	4.7K	"	"	"	
R319	100K	"	"	"	
R320	"	"	"	"	
R321	2M	"	"	"	
R322	15K	"	"	"	
R323	4.7M	1/2	±10	Solid	
R324	220K	1/4	±5	Carbon	
R325	68K	"	"	"	
R326	33K	"	"	"	
R327	18K	"	"	"	
R328	1.8K	"	"	"	
R329	68K	"	"	"	
R330	100K	"	"	"	
R331	22K	"	"	"	
R332	3.3K	"	"	"	
R333	1K	"	"	"	
R334	68K	"	"	"	
R335	100K	"	"	"	
R336	"	"	"	"	
R337	8.2K	"	"	"	
R338	9.1K	"	"	"	
R351	1.8K	"	"	"	
R352	100K	"	"	"	

Ref. No.	Description				R/S Part No.
	Value (ohm)	Watt-age	Tolerance (%)	Material	
R353	2.2M	1/4	±5	Carbon	
R401	390K	"	"	"	
R402	1.5K	"	"	"	
R403	470	"	"	"	
R404	8.2	"	"	"	
R405	15K	"	"	"	
R406	3.9K	"	"	"	
R407	27K	"	"	"	
R408	1.8K	"	"	"	
R409	Not Used				
R410	27	1/4	±5	Carbon	
R411	470	"	"	"	
R412	"	"	"	"	
R413	27K	"	"	"	
R414	470	"	"	"	
R415	27K	"	"	"	
R416	4.7K	"	"	"	
R417	1K	"	"	"	
R418	470	"	"	"	
R419	150K	"	"	"	
R420	100K	"	"	"	
R421	47K	"	"	"	
R422	100K	"	"	"	
R423	7.5K	"	"	"	
R424	12K	"	"	"	
R425	22K	"	"	"	
R426	Not Used				
R427	"				
R428	"				
R429	"				
R430	"				
R431	"				
R432	"				
R433	100K	1/4	±5	Carbon	
R434	4.7K	"	"	"	
R551a,b	22K	"	"	"	
R552a,b	"	"	"	"	
R601a,b,c,d	3.9K	"	"	"	
R602a,b,c,d	120K	"	"	"	
R603a,b,c,d	18K	"	"	"	
R604	3.3K	"	"	"	
R605a,b,c,d	3.9K	"	"	"	
R606a,b,c,d	56	"	"	"	
R607a,b,c,d	1.6K	"	"	"	
R608a,b,c,d	27K	"	"	"	

Ref. No.	Description				R/S Part No.
	Value (ohm)	Wattage	Tolerance (%)	Material	
R609a,b,c,d	2.2K	1/4	±5	Carbon	
R610a,b,c,d	6.8K	"	"	"	
R611a,b,c,d	3.9K	"	"	"	
R612a,b,c,d	2.2K	"	"	"	
R613a,b,c,d	820	"	"	"	
R614a,b,c,d	100	"	"	"	
R615a,b,c,d	"	"	"	Non Flame Carbon	
R616a,b,c,d	10	"	"	"	
R617a,b,c,d	100	"	"	"	
R618a,b,c,d	10	"	"	"	
R619a,b,c,d	220	"	"	Carbon	
R620a,b,c,d	0.5	5	±10	Wire Wound	
R621a,b,c,d	"	"	"	"	
R622a,b,c,d	270	1/4	±5	Carbon	
R623a,b,c,d	"	"	"	"	
R624a,b,c,d	120	"	"	"	
R625a,b,c,d	"	"	"	"	
R626a,b,c,d	100	"	"	Non Flame Carbon	
R627a,b,c,d	10	1	±10	Metal Fixed	
R651a,b,c,d	220	"	"	Metal-Oxide	
R701	2.2M	1/4	±5	Carbon	
R701-1a,b	180K	"	"	"	
R701a,b	2.2K	"	"	"	
R701c,d	4.3K	"	"	"	
R701e,f,g,h	6.8K	"	"	"	
R702	220K	"	"	"	
R702-1	12K	"	"	"	
R702a,b	"	"	"	"	
R702c,d	4.3K	"	"	"	
R702e,f,g,h	10K	"	"	"	
R703	1K	"	"	"	
R703-1	47K	"	"	"	
R703a,b	680K	"	"	"	
R703c,d	3.6K	"	"	"	
R703e,f,g,h	56K	"	"	"	
R704	820K	"	"	"	
R704a,b	15K	"	"	"	
R704c,d	3.6K	"	"	"	
R704e,f,g,h	10K	"	"	"	
R705	6.8K	"	"	"	
R705a,b	470	"	"	"	

Ref. No.	Description				R/S Part No.
	Value (ohm)	Wattage	Tolerance (%)	Material	
R705c,d	220K	1/4	±5	Carbon	
R705e,f,g,h	820K	"	"	"	
R706	820	"	"	"	
R706a,b	270K	"	"	"	
R706c,d	220K	"	"	"	
R707	100K	"	"	"	
R707a,b	6.2K	"	"	"	
R707c	7.5K	"	"	"	
R708	33K	"	"	"	
R708a,b	1K	"	"	"	
R708c	47K	"	"	"	
R709	1.5K	"	"	"	
R709a,b	330K	"	"	"	
R709c,d	100K	"	"	"	
R710	22K	"	"	"	
R710a,b	27K	"	"	"	
R710c,d	5.6K	"	"	"	
R711	1.5K	"	"	"	
R711a,b	4.7K	"	"	"	
R711c,d	3.3K	"	"	"	
R712	22K	"	"	"	
R712a,b	10K	"	"	"	
R712c,d	220K	"	"	"	
R713	1.5K	"	"	"	
R713a,b	430K	"	"	"	
R713c,d	100	"	"	"	
R714	150	"	"	"	
R714a,b	27K	"	"	"	
R714c	1.5K	"	"	"	
R715	2.7K	"	"	"	
R715a,b	10K	"	"	"	
R715c	6.8K	"	"	"	
R716	2.2K	"	"	"	
R716a,b	150	"	"	"	
R716c	3.9K	"	"	"	
R717	2.7K	"	"	"	
R717a,b	5.6K	"	"	"	
R717c	1K	1	±10	Metal Fixed	
R718	47K	1/4	±5	Carbon	
R718a,b	10K	"	"	"	
R718c,d	270K	"	"	"	
R719	22K	"	"	"	
R719a,b	10K	"	"	"	

Ref. No.	Description				R/S Part No.
	Value (ohm)	Wattage	Tolerance (%)	Material	
R719c,d	100K	1/4	±5	Carbon	
R720	220K	"	"	"	
R720a,b	2.2K	"	"	"	
R720c,d	3.3K	"	"	"	
R721	220K	"	"	"	
R721a,b	2.2K	"	"	"	
R721c,d	3.3K	"	"	"	
R722	220K	"	"	"	
R722a,b	2.7K	"	"	"	
R722c,d	220K	"	"	"	
R723a,b	330	"	"	"	
R723c,d	68K	"	"	"	
R724a,b	150K	"	"	"	
R724c,d	10K	"	"	"	
R725a,b	6.8K	"	"	"	
R726a,h	4.7K	"	"	"	
R727a,b	220	"	"	"	
R728a,b	18K	"	"	"	
R729a,b	270K	"	"	"	
R730a,b	56K	"	"	"	
R731a,b	47K	"	"	"	
R732a,b	6.8K	"	"	"	
R733a,b	4.7K	"	"	"	
R734a,b	6.8K	"	"	"	
R735a,b	18K	"	"	"	
R736a,b	47K	"	"	"	
R737a,b	390K	"	"	"	
R738a,b	100	"	"	"	
R739a,b	8.2K	"	"	"	
R740a,b	150K	"	"	"	
R741a,b	470K	"	"	"	
R742a,b	100K	"	"	"	
R743a,b	27K	"	"	"	
R744a,b	8.2K	"	"	"	
R745a,b	39K	"	"	"	
R746a,b	270K	"	"	"	
R747a,b	4.7K	"	"	"	
R748a,b	120	"	"	"	
R749a,b	68K	"	"	"	
R750a,b	33K	"	"	"	
	Not Used				
	100K	1/4	±5	Carbon	
	Not Used				

Ref. No.	Description				R/S Part No.
	Value (ohm)	Wattage	Tolerance (%)	Material	
R752a,b	100K	1/4	±5	Carbon	
R753	Not Used				
R753a,b	27K	1/4	±5	Carbon	
R754a,b	2.2K	"	"	"	
R755a,b	220K	"	"	"	
R756a,b	68K	"	"	"	
R757a,b	3K	"	"	"	
R758a,b	6.8K	"	"	"	
R759a,b	8.2K	"	"	"	
R760a,b	3.9K	"	"	"	
R761a,b	1K	"	"	"	
R762a,b	"	"	"	"	
R763a,b	47K	"	"	"	
R764a,b	180K	"	"	"	
R765a,b	22K	"	"	"	
R766a,h	5.6K	"	"	"	
R767a,b	12K	"	"	"	
R768a,b	8.2K	"	"	"	
R769a,b	3.3K	"	"	"	
R770a,b	220K	"	"	"	
R771a,b	470K	"	"	"	
R772a,b	1.8K	"	"	"	
R773a,b	"	"	"	"	
R774a,b	10K	"	"	"	
R775a,b	"	"	"	"	
R776a,b	8.2K	"	"	"	
R777a,b	10K	"	"	"	
R778a,b	2.7K	"	"	"	
R779a,b	330	"	"	"	
R780a,b	150	"	"	"	
R781a,b	82K	"	"	"	
R782	2.7K	"	"	"	
R783	100K	"	"	"	
R784	4.7K	"	"	"	
R785	8.2K	"	"	"	
R786	68	"	"	"	
R787	18K	"	"	"	
R788	1.8K	"	"	"	
R789	33K	"	"	"	
R790	"	"	"	"	
R791	8.2K	"	"	"	
R792	18K	"	"	"	
R793	"	"	"	"	

SWITCHES		Ref. No.	Description	R/S	Part No.
StarK	Selector	S-1181			27100101
S2~n	Mode	S-1183			27100102
S3	Audiotator	S-1182			27100100
S4~S9	Function (6 keys)	S-7213			27200063
S10, S11	Speakers	S-7212			27200062
S12	Power (UL)				27200064
S13	Phono Level				27300008
S14	Thermal Switch (UL)	S-0647			30700130
TRANSFORMERS & COILS		Ref. No.	Description	R/S	Part No.
L101	FM Antenna Coil	119A			35501191
L102	FM RF Coil	121B			35501212
L103	"	119A			35501191
L104	FM Choke Coil				35500070
L105	FM OSC Coil	114L			35501146
L151	FM Balun Transformer				35500060
L201	Inductor 144LY-330K				35500160
L202	"				
L203	Not Used				
L204	"				
L205	Inductor 144LY-330K				35500160
L206	Inductor LT-B33				35500090
L301	Choke Coil	40mH			35500250
L302	"				
L303	Inductor 141LY 102K				36600160
L401	AM RF Coil	112B			35501122
L402	AM OSC Coil	407L			35504076
L451	AM Bar Antenna				35400381
L601a,b,c,d	Choke Coil	8μH			35500170
L701a,b	Choke Coil	92mH			35500260
LP702a,b	Low Pass Filter BL-12NN				35000030
T101	FM IFT	107A			35701071
T201	FM IFT	214D			35702144
T401	AM IFT	404B			35704042
T402	"				
T851	Power Transformer (UL)				35900158
"	"				
"	"				35900159
"	"				35900160

Description		Ref. No.	Value (ohm)	Wattage	Tolerance (%)	Material	R/S	Part No.
Carbon		R794	10K	1/4	±5			
Non Flame		R795	100	"	"			
Carbon		R796	"	"	"			
Carbon		R797	1K	1	±10			
Metal Fixed		R798	1.8K	1/4	±5			
Carbon		R799	18K	"	"			
Non Flame		R801	33	2	±10			
Metal Fixed		R802	6.8K	1/4	±5			
Carbon		R803	47	"	"			
Non Flame		R804	15	"	"			
Carbon		R805	47	2	±10			
Metal Fixed		R806	1.2K	1/4	±5			
"		R807	33	"	"			
Non Flame		R808	10	"	"			
Carbon		R851	2.2M	1/2	"			
Carbon		R901a,b,c,d	82K	1/4	±5			
"		R902a,b,c,d	10K	"	"			
"		R903a,b,c,d	1K	"	"			
"		R904a,b,c,d	470K	"	"			
"		R905a,b,c,d	82K	"	"			
"		R906a,b,c,d	1K	"	"			
"		R907a,b,c,d	4.7K	"	"			
"		R908a,b,c,d	"	"	"			
"		R909a,b,c,d	"	"	"			
"		R910a,b,c,d	1K	"	"			
"		R911a,b,c,d	6.8K	"	"			
"		R912a,b,c,d	"	"	"			
"		R913a,b,c,d	15K	"	"			
"		R914a,b,c,d	"	"	"			
"		R915a,b,c,d	"	"	"			
"		R916a,b,c,d	"	"	"			
"		R917a,b,c,d	820K	"	"			
"		R918a,b,c,d	6.8K	"	"			
"		R919a,b,c,d	20K	"	"			
"		R920	560	"	"			

TRANSISTORS

Ref. No.	Type No.	R/S Part No.	Part No.	Manufacturer	Substitute	
					Type No.	Manufacturer
TR101	3SK45		30400071	Hitachi	3SK41	NEC
TR102	2SC1047		30200461	Matsushita	2SC839	"
TR103	"		"	"	"	"
TR201	2SC710		30200382	Mitsubishi	2SC930	Sony
TR202	"		"	"	"	"
TR203	2SC828		30200242	Matsushita	2SC1364	Sony
TR301	2SC1364		30200862	Sony	2SC828	Matsushita
TR302	"		"	"	"	"
TR303	2SA641		30000111	NEC	2SA678	Sony
TR304	2SC1364		30200862	Sony	2SC828	Matsushita
TR305	2SA641		30000111	NEC	2SA678	Sony
TR306	2SC1364		30200862	Sony	2SC828	Matsushita
TR307	"		"	"	"	"
TR401	2SC930		30200271	Sony	BF254	Siemens
TR402	"		"	"	"	"
TR403	"		"	"	"	"
TR404	MPSA-13		30200750	Motorola		
TR601a,b,c,d	2SA763		30000331	JRC	2SA640	NEC
TR602a,b,c,d	"		"	"	"	"
TR603a,b,c,d	2SC1509		30200963	Matsushita	2SC1670	Sony
TR604a,b,c,d	2SC1539		30200921	Toyo Electronics		
TR605a,b,c,d	2SC1509		30200963	Matsushita	2SC1670	Sony
TR606a,b,c,d	2SA777		30000373		2SA840	Sony
TR607a,b,c,d	2SC1051		30200982	Sony	2SC1402	Sanken
TR608a,b,c,d	2SC1051		"	"	"	"
TR609a,b,c,d	2SC828		30200241	Matsushita	2SC/11	Mitsubishi
TR610a,b,c,d	2SA733		30000423	NEC	2SA678	Sony
TR701	2SC828		30200242	Matsushita	2SC711	Mitsub.
TR702	"		"	"	"	"
TR703	"		"	"	"	"
TR704	"		"	"	"	"
TR705	2SC1384		30200603	Matsushita	2SC1175	Sony
TR706	"		"	"	"	"
TR701a,b,c,d	2SC1362		30200851	Sony	2SC1000	Toshib
TR702a,b,c,d	"		"	"	"	"
TR703a,b	2SC1362		30200851	Sony	2SC1000	Toshib
TR704a,b	"		"	"	"	"
TR705a,b	2SA763		30000331	JRC	2SA640	NEC
TR706a,b	2SC1362		30200851	Sony	2SC1000	Toshib
TR707a,b	2SC828		30200241	Matsushita	2SC711	Mitsub
TR708a,b	2SK40		30400082	Hitachi		
TR709a,b	2SC828		30200241	Matsushita	2SC711	Mitsub
TR710a,b	2SK40		30400081	Hitachi		
TR711a,b	2SC1362		30200851	Sony	2SC1000	Toshiba
TR712a,b	"		"	"	"	"
TR713a,b	"		"	"	"	"
TR714a,b	"		"	"	"	"
TR715	2SC1636		30201071	Sony		

Substitute		Manufacturer		Type No.		Manufacturer	
TR716	ZSC828	Matsushita	30200241	Mitsubishi	ZSC711	Mitsubishi	
TR717	"	"	"	"	"	"	
TR718	ZSC1364	Sony	30200861	NEC	ZSC945	NEC	
TR719	"	"	"	"	"	"	
TR720	"	"	"	"	"	"	
TR721	ZSC828	Matsushita	30200241	Mitsubishi	ZSC711	Mitsubishi	
TR722	ZSC1364	Sony	30200861	NEC	ZSC945	NEC	
TR801	ZSD330	Sanyo	30300192	Hitachi	ZSC1419	Hitachi	
TR802	"	"	"	"	"	"	
TR901a,b,c,d	ZSC1362	Sony	30200851	Toshiba	ZSC1000	Toshiba	
TR902a,b,c,d	ZSA763	JRE	30000331	NEC	ZSA640	NEC	
TR903a,b,c,d	ZSC1362	Sony	30200851	Toshiba	ZSC1000	Toshiba	
VC101	Tuning gang (include TC101-103, 105-107)	C-4516	26370081				
TC104	Trimmer	C-0447	26010093				
VARIABLE CAPACITORS				VARIABLE RESISTORS			
Ref. No.	Description	R/S Part No.	Mfr's Part No.	Ref. No.	Description	R/S Part No.	Mfr's Part No.
VR201	Meter Setting 5K Ω /B	P-6271	28100055	VR201	Meter Setting 5K Ω /B	P-6271	28100055
VR301	MPX. Separation Control 50K Ω /B	P-6272	28100082	VR301	MPX. Separation Control 50K Ω /B	P-6272	28100082
VR302	Muting & Auto Stereo Setting 20K Ω /B	P-1164	28100008	VR302	Muting & Auto Stereo Setting 20K Ω /B	P-1164	28100008
VR303	PLL MPX. Phase Lock Control 5K Ω /D	P-6273	28100083	VR303	PLL MPX. Phase Lock Control 5K Ω /D	P-6273	28100083
VR401	AM AGC Control 500K Ω /B	P-6270	28100040	VR401	AM AGC Control 500K Ω /B	P-6270	28100040
VR402	AM Output Level Control 5K Ω /B		28100083	VR402	AM Output Level Control 5K Ω /B		28100083
VR601a,b,c,d	Idling Current Control 1K Ω /B	P-6274	28100037	VR601a,b,c,d	Idling Current Control 1K Ω /B	P-6274	28100037
VR701a,b	CD-4 OSC Freq. Control 2K Ω /B	P-6275	28100084	VR701a,b	CD-4 OSC Freq. Control 2K Ω /B	P-6275	28100084
VR702a,b	CD-4 SUB CH. Level Control 5K Ω /B	P-6276	28100085	VR702a,b	CD-4 SUB CH. Level Control 5K Ω /B	P-6276	28100085
VR703a,b	CD-4 LOW Freq. ANRS Control 20K Ω /B	P-6277	28100086	VR703a,b	CD-4 LOW Freq. ANRS Control 20K Ω /B	P-6277	28100086
VR704a,b	CD-4 HIGH FREQ. ANRS Control 20K Ω /B		28100086	VR704a,b	CD-4 HIGH FREQ. ANRS Control 20K Ω /B		28100086
VR751a,b	CD-4 Separation Control 5K Ω /B	P-1528	28000096	VR751a,b	CD-4 Separation Control 5K Ω /B	P-1528	28000096
VR901a,b,c,d	Treble Control 100K Ω /Bx4	P-1531	28000094	VR901a,b,c,d	Treble Control 100K Ω /Bx4	P-1531	28000094
VR902a,b,c,d	Midrange Control 100K Ω /Bx4	"	"	VR902a,b,c,d	Midrange Control 100K Ω /Bx4	"	"
VR903a,b,c,d	Bass Control 100K Ω /Bx4	"	"	VR903a,b,c,d	Bass Control 100K Ω /Bx4	"	"
VR951a,b,c,d	Volume Control 200K Ω /Bx2	P-1530	28200092	VR951a,b,c,d	Volume Control 200K Ω /Bx2	P-1530	28200092
VR952a,b,c,d	Balance Control 20K Ω /MIV		28000095	VR952a,b,c,d	Balance Control 20K Ω /MIV		28000095

MISCELLANEOUS PARTS LIST

Ref. No.	Description	R/S Part No.	Mfr's Part No.	Ref. No.	Description	R/S Part No.	Mfr's Part No.
1	Back Panel		11123003	44	Spring for Meter		19041002
2	AC Outlet 1R02 (UL)	J-0650	34048001	45	Meter 250 μ A	M-0257	60250003
3	Fuseholder FH-002 (UL)		34032001	46	Fiber for Meter		08038002
4	Fuse 5A 125V (UL)	HF-1090	38100050	47	Wrapping Pin 19		19043001
5	4P Screw Terminal		53041600	48	Spring Washer M3		42250341
6	15P Pin Jack terminal	J-0649	33150100	49	Tapping Screw M3x6		40130061
7	12P Screw Terminal		53120130	50	Pilot Lamp Grommet		74001002
8	8P Screw Terminal		53082330	51	Lug Terminal 2P1L2P		51024002
9	Cord Strain relief (UL)		74089001	52	Light Shielding Foam		73185001
10	Cord Stopper		74035001	53	Light Shielding Fiber A		73188002
11	AM Bar Antenna L451	GA-0230	35400381	54	Light Shielding Fiber B		73189001
12	Bar Ant. Holder		63030001	55	Light Shielding Foam		73187001
13	Bracket for Bar Ant. Holder		63026002	56	Plane Washer M3		74210001
14	Nut M4		40000030	57	Power SW Insulating Fiber		73191001
15	Screw M4x45		40340451	58	Light Shielding Fiber		73161001
16	Flat Plane Washer M4		42120421	59	Insulating Fiber		75055001
17	Tapping Screw M3x8		40140081	60	Side Chassis		01070001
18	Screw M3x8		40330081	61	Center Chassis		01071001
19	Screw M3x6		40330061	62	Power Transformer Bracket		63990002
20	Line Cord Ant. Clamper		63101001	63	Dial Drum		21009001
21	Line Cord Ant. Fiber		75017002	64	Spring for Dial Drum	RB-5314	19045001
22	Pulley Shaft E		24003001	65	Dial String		84156001
23	Bracket for Pulley Shaft		63268001	66	Polyethylene Spacer		55046001
24	Plastic Pulley	D-0250	84085001	67	Tapping Screw M3x15		40130151
25	Line Cord with Plug (UL)		62110004	68	Dial Pointer	D-1141	25034001
26	Ground Terminal		53012300	69	Wiring Bracket		63075001
27	Solder Lug M3		51036001	70	Bracket for Wooden Cabinet		63287001
28	Nut M3		41113070	71	Lug Terminal 1P1L1P		51041002
29	Flat Washer M3		42110321	72	Heat Sink		15059002
30	Lockwasher		42380331	73	Snap Bushing		74037001
31	Front Chassis		03053005	74	Bracket for Thermal SW		63255001
32	Headphone Jack	J-0431	33030400	75	Insulating Fiber for Thermal SW		84159001
33	Headphone Jack	J-0651	33030100	76	Sub Heat Sink		15061002
34	Lamp Diffuser		84177002	77	Heat Sink C		15062001
35	Dial Scale	G-0194	20080001	78	Tapping Screw M3x12		40130121
36	Rubber for Dial Scale		63280001	79	Front Panel	Z-2269	10172001
37	Rubber for Dial Scale		74098001	80	Tuning Knob		29161001
38	Dial Scale	D-3149	23041003	81	Selector Knob		29162002
39	Dial Shaft		75047001	82	Knob A	K-1829	29163001
40	Insulating V		75048001	83	Knob B	K-1830	29164001
41	Pulley Shaft		24011002	84	Knob C	K-1832	29170001
42	Dial Lamp House		0801001	85	Audiotape Knob	K-1833	29171001
43	Meter Lamp Diffuser		6420				

Ref. No.	Description	R/S Part No.	Mfr's Part No.
86	Push SW Knob	K-1834	19172001
87	Slide Volume Knob	K-1831	29166001
88	Wooden Cabinet		85055009
89	Bottom Chassis		05041004
90	Screw M5x20		40350201
91	Screw M5x12		40350121
92	Tapping Screw M4x6		40640061
93	Plastic Foot		74074001
94	Insulating Fiber		75061001
95	Plastic Washer for Cabinet		84092001
96	Volume Cap		74103001
97	M4x15 Bronze Screw		40640155
98	Acryl for Indicator		71036001

FOUSADRE
FOODSASIS