

FIVE BAND MONO FREQUENCY EQUALIZER

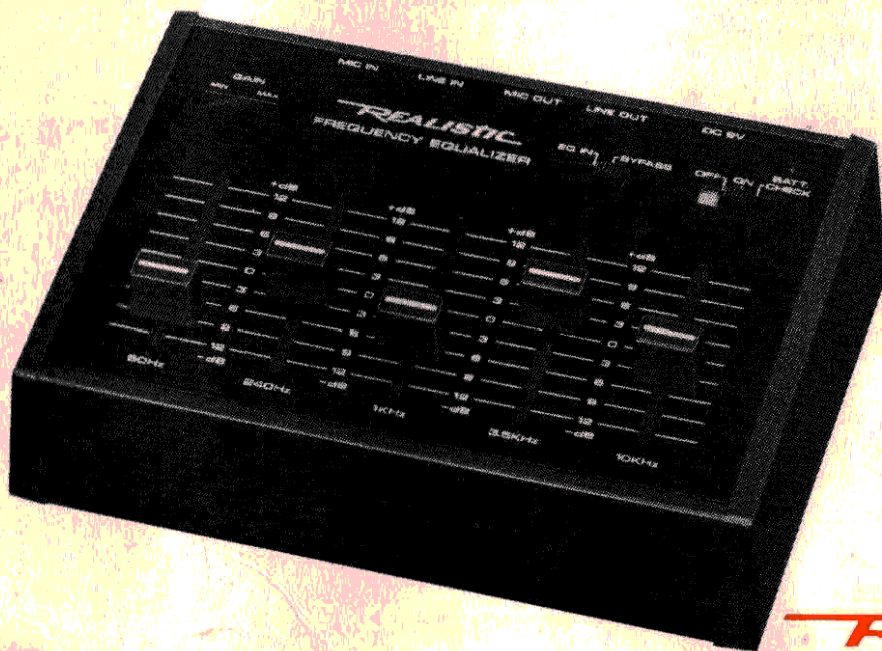

OWNER'S MANUAL

PLEASE READ BEFORE
USING THIS EQUIPMENT

REALISTIC[®]

**Cat. No.
32-1115**

CUSTOM MANUFACTURED FOR RADIO SHACK, A DIVISION OF TANDY CORPORATION

With the REALISTIC[®] Five Band Mono Frequency Equalizer you can tailor the sound for your individual surroundings and individual performances. Operating from either DC or AC power, it can be hooked up anywhere . . . with a public address system at an outdoor gathering or auditorium assemblage.

Customized sound is important because regular tone control affects too broad a range in the audio spectrum. When the volume is increased in the low bass, it "spills over" into the middle bass, and muddies up the sound. The same is true with the treble control.

Your Equalizer gives you control of five individual frequency ranges and yields low distortion. The controls have a range of approximately 24 dB (+/-12 dB) and are marked in 3 dB increments. (The ear's low frequency response can drop as much as 12 dB at normal conversational level.)

The Equalizer gives you greater control of audio enhancement for both instrumental and vocal performance. Its compact size makes it a convenient, portable piece of equipment.

The components in your Equalizer are of the highest quality and will bring you many years of good listening!

Copyright Tandy Corporation, 1983

SPECIFICATIONS

Frequency Response (150 mV output)	: +/-1 dB (20 – 20,000 Hz)
Tone Control Ranges	: ±12 dB @60, 240, 1,000, 3,500 and 10,000 Hz
Harmonic Distortion	: 0.2% @150 mV output (20 – 20,000 Hz)
Dynamic Range at MIC (GAIN Control Min.)	: 150 mV at 1% THD
Total Gain (flat setting)	
MIC IN to MIC OUT	: 0 dB
LINE IN to LINE OUT	: 0 dB
MIC IN to LINE OUT	: 40 dB
Input Impedance	
MIC	: 10K ohms at 1 kHz
LINE	: 50K ohms at 1 kHz
Output Impedance	: 100 ohms at 1 kHz
Power Requirements	: DC 9 volts (AA cell 1.5V x 6)

For your important records, enter the serial number of this unit in the space provided. You'll find the serial number on the back panel of the unit.

Serial Number:

CONTROLS

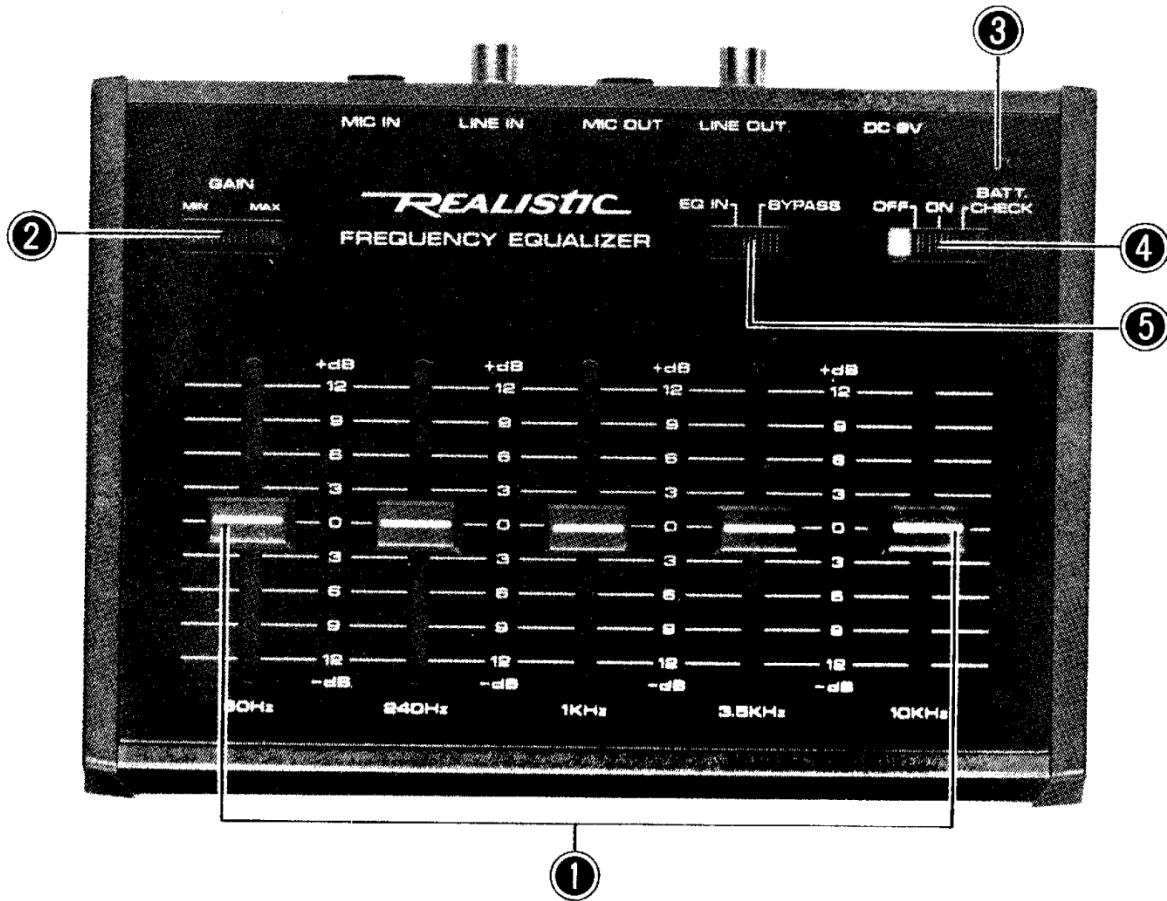

- ① **Frequency Slide Controls** control the frequency response permit a boost or cut up to 12 dB at the frequencies shown below each control.
- ② **GAIN Control** rotates to control the input level. The green line on the control indicates the setting for the usual position.
- ③ **BATTERY CHECK LED** indicates the battery condition when the ON/OFF/BATTERY CHECK Switch is set to the BATT CHECK position. If it does not light, replace the batteries.
- ④ **ON/OFF/BATTERY CHECK Switch** ON activates the Equalizer; OFF turns it off. BATTERY CHECK indicates the condition of the batteries.
- ⑤ **EQ IN/BYPASS Switch** BYPASS disconnects the equalizer circuit from the signal path. When you want to equalize the sounds, keep it to EQ IN.

JACKS

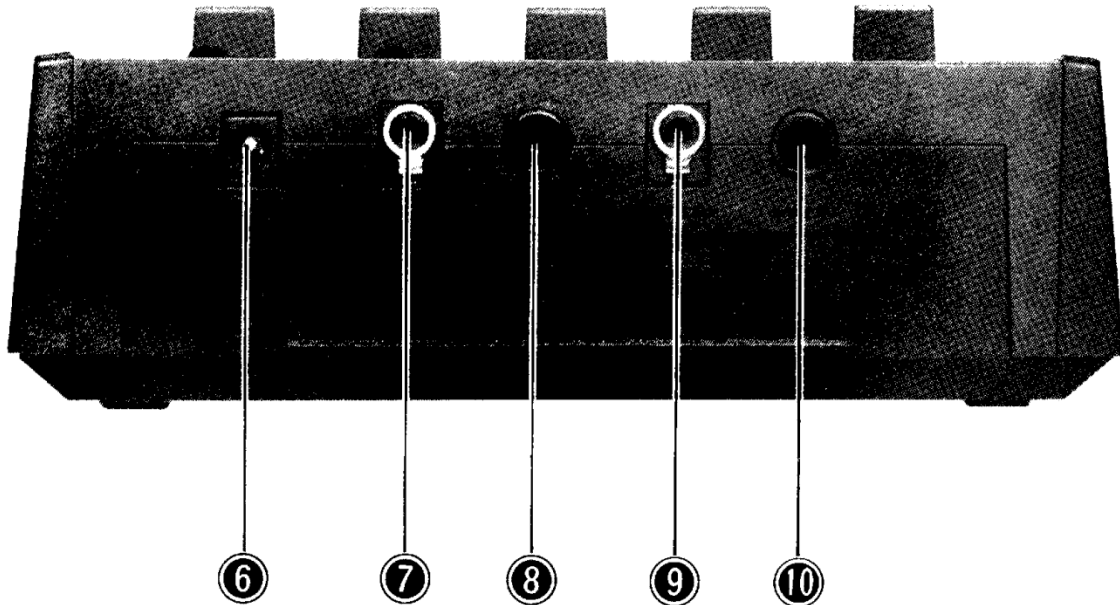

- ⑥ **DC 9V Jack** is the connection for the standard AC outlet using Radio Shack's AC adapter Catalog Number 273-1455 (270-7001 for 240V U.K., 270-9553 for 240V Australia).
- ⑦ **LINE OUT Jack*** is the connection for the AUX jack of your PA amplifier; or for the line from the input jack of your amplifier, receiver, tape deck, etc.
- ⑧ **MIC OUT Jack** is the connection for the microphone jack of your PA amplifier or tape deck using mike cable (Radio Shack Cat. No. 42-2381 or equivalent.)
- ⑨ **LINE IN Jack*** is the connection for the output jack of your PA amplifier, receiver or tape deck.
- ⑩ **MIC IN Jack** is the connection for any microphone (high or low impedance) with a 1/4" (6.35 mm) plug.

* If you are using a PA amplifier that has equalizer/bypass switch, connect the Equalizer's LINE IN and OUT jacks to the PA amplifier's EQ IN and OUT jacks.

INSTALLATION

Whether you use either batteries or adapter to supply power to your Equalizer, read the following instructions carefully for proper installation.

Batteries

The battery compartment is in the bottom of the unit. Open the lid and install six 1.5 volt AA cells as illustrated below.

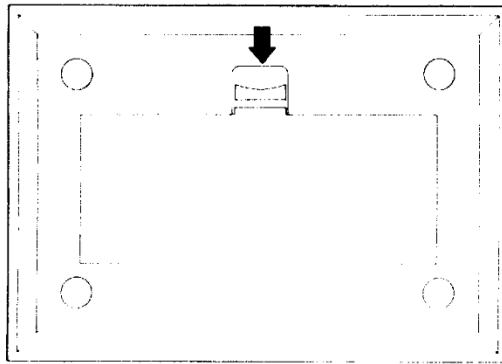

Figure 1

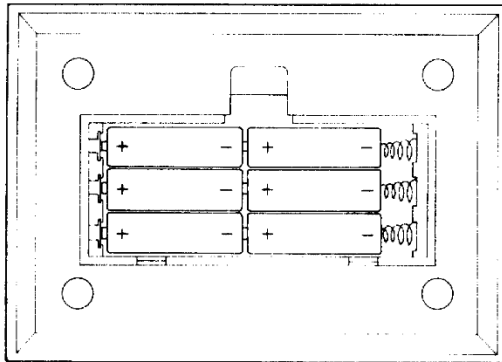

Figure 2

Caution: Be sure to observe proper polarity (+ and -). Improper installation could damage the unit.

Adapter

You can use an AC adapter wherever AC power is available, provided you use Radio Shack's AC adapter, Catalog Number 273-1455. Connect the adapter to the DC 9V jack, and then plug the other end into the wall receptacle.

Note: Use 270-7001 for U.K., and 270-9553 for Australia.

Or, you can power the Equalizer from your vehicle's cigarette lighter socket, if your car has a 12-volt negative ground-system. Use our 14-844D auto adapter. Set the voltage switch to 9V.

Caution: Be sure to use only the Radio Shack Adapter 273-1455 (which provides 9 Volts DC only, with center terminal negative). Failure to do so could result in damage to your player and/or adapter. Always be sure to remove the batteries when operating your Equalizer with the adapter.

Battery Check

Slide the ON/OFF/BATTERY CHECK switch to BATTERY CHECK. If the BATTERY CHECK LED lights, the batteries are in good condition. When the LED is dim or does not light, the batteries need replacing.

We recommend Radio Shack's 23-552 long-life alkaline ENERCELL batteries or the rechargeable 23-125 batteries if you want to use a battery charger.

Maintenance

- Test the batteries at least once a week.
- Replace the batteries as soon as the BATTERY CHECK LED fails to light.
- Remove the batteries when you do not intend to use your unit for over a week or more. Also never leave weak or dead batteries within the unit. Even "leak-proof" batteries can leak chemicals that will damage your unit permanently.

CONNECTIONS

Preparation

1. Be sure the power switches of all equipment in use are turned off.
2. For MIC OUT connection, use a cable fitted with a 1/4" phone plug at one end. The other end may also be a 1/4" phone plug or 1/8" mini plug, depending on the connection you want to make.

Examples

There are numerous ways to hook up the Equalizer. You will decide which is the best setup for your needs. But the following examples suggest different connections that may give you some helpful ideas. See also Jacks and Signal Flow on page 13.

A. Connecting an Electronic Instrument

With the PA amplifier incorporating the equalizer/bypass function, you can hook up a synthesizer or electronic musical instrument and be able to reduce feedback and still be able to fill the acoustical space of your environment.

1. Connect your electronic instrument to MIC IN.
2. Connect LINE IN/OUT to the PA amplifier's equalizer/bypass IN/OUT jacks.

Note: If auxiliary or line input jack on your PA amp is being used, you can connect Equalizer's MIC OUT to the PA amp's mic in jack.

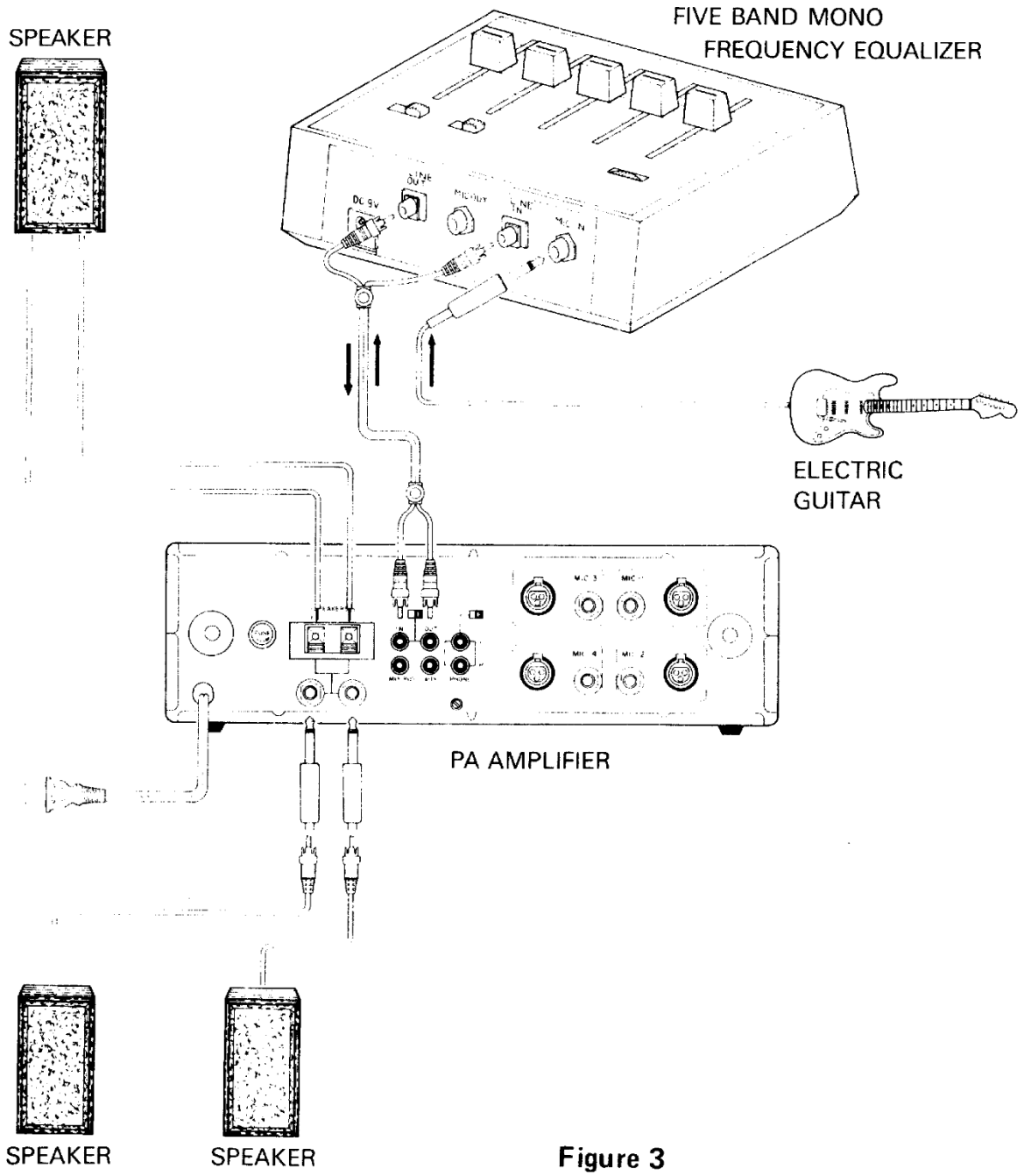

B. Connecting a Microphone

With the connection in Figure 4 you are going to equalize the signal from the mic and send it out through the PA amplifier.

1. Connect your microphone to MIC IN on your equalizer.
2. Connect LINE OUT to the PA amplifier's aux jack.

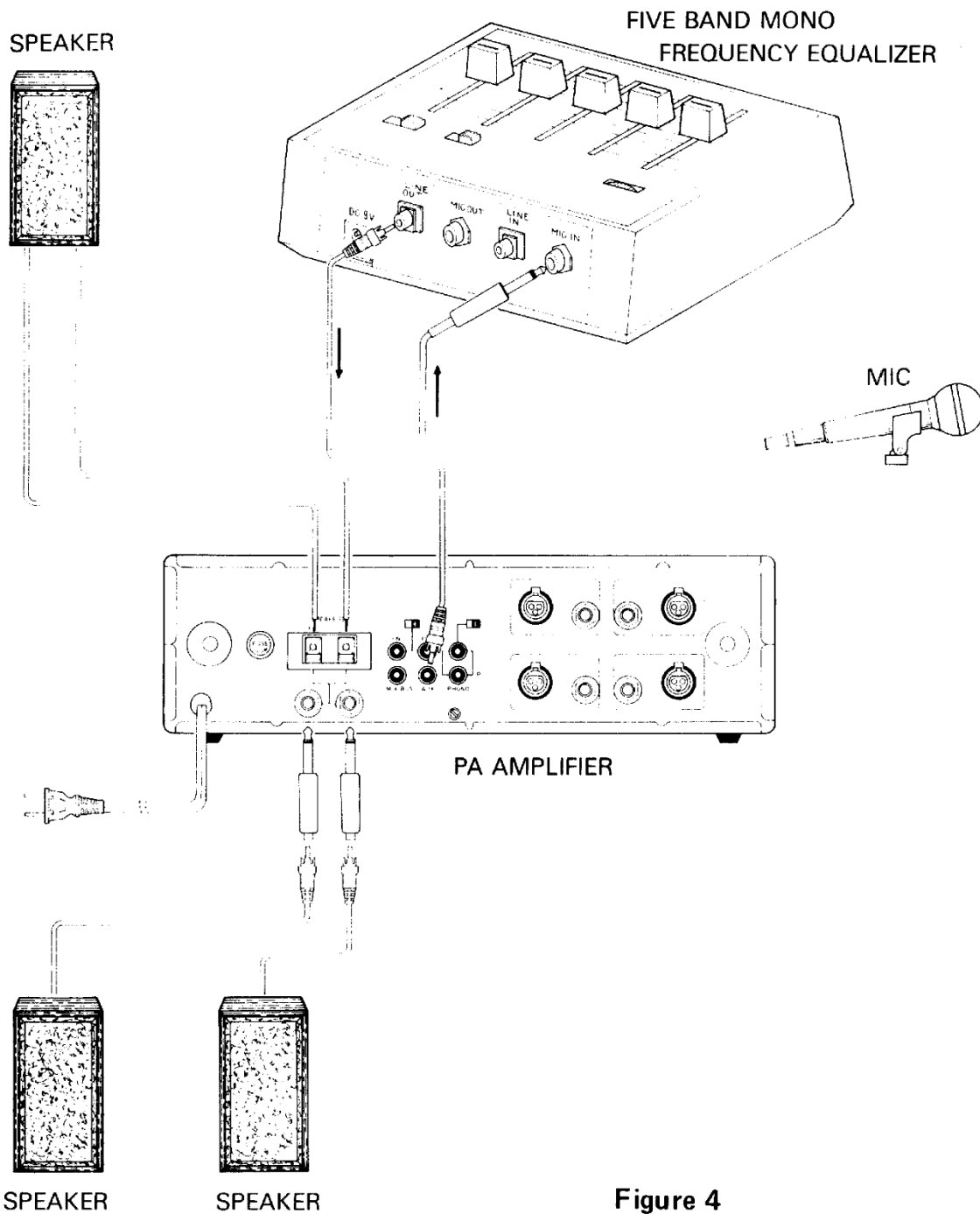

Figure 4

C. Connecting Mic and Tape Recorder

With a PA amplifier and tape recorder (Figure 5) the signals from the microphone and tape recorder are equalized and processed through the PA amplifier.

1. Connect your microphone to MIC IN.
2. Connect LINE IN to the tape recorder's tape out jack.
3. Connect LINE OUT to PA amplifier's aux jack. If the aux jack is already being used, use mic input to make connection to your Equalizer's MIC OUT.

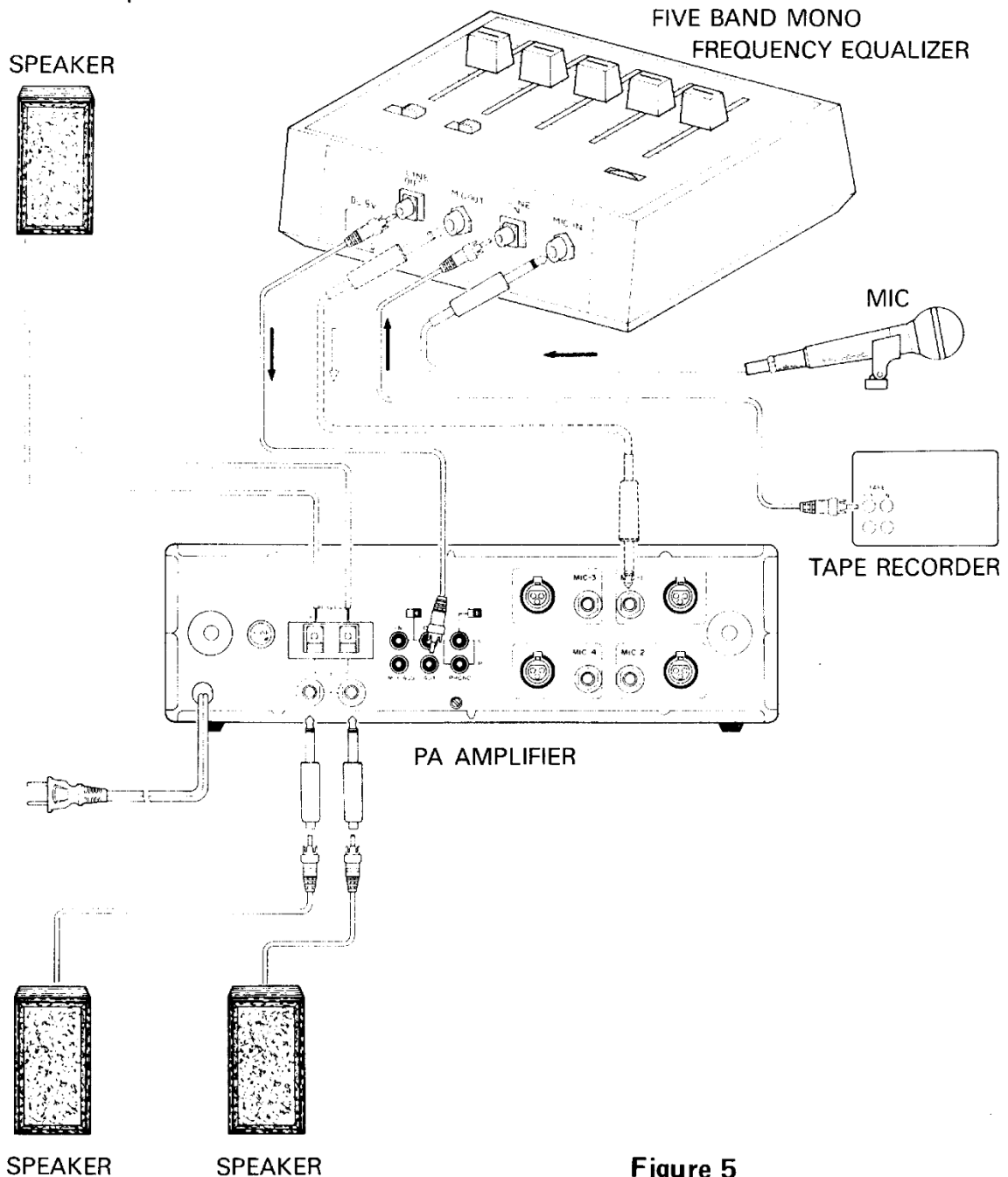

Figure 5

OPERATION

1. Make the appropriate connections.
2. Set the volume control on your PA amplifier, receiver, etc. to minimum, and the tone controls at their middle (flat) position.
3. First turn on the Equalizer, then the tape recorder (when in use), and last the PA amplifier.
4. Select the signal source through your PA amplifier.
5. Adjust the Frequency Slide Controls of the Equalizer for the desired sound.
6. If the input signal level is too high and causes distortion, move Equalizer's GAIN control to a lower setting. If too low, set it higher.

Notes on Operation

- When connected to the equalizer/bypass in and out jacks of a PA amplifier (Figure 3), set the EQ/Bypass switch of both the PA amplifier and the Equalizer to the EQ position when you want to equalize the signal. If either one of the switches is set to BYPASS position, the signal will bypass the Equalizer circuit.
- When connected to the microphone jack of a tape recorder, you can record the equalized signal, but you can only monitor it when wearing headphones. During the recording, be sure the recorder is not connected to the amplifier.

Jacks and Signal Flow

The MIC IN and LINE IN signals go to both MIC OUT and LINE OUT at the same time. When you use both input jacks the mixed signal will go to both output jacks simultaneously. You can “sing along” with your favorite music (or record one output while “broadcasting” the other). Refer to Figures 6 and 7.

Note: The line and mic signals are mixed through both output jacks (even when the EQ IN/BYPASS switch on the Equalizer is set to BYPASS). But you cannot tailor the sound when the switch is set to BYPASS.

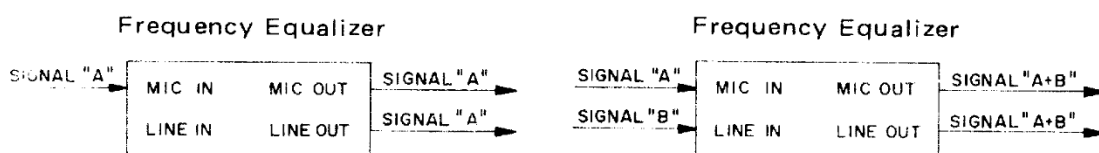

Figure 6

Figure 7

Although the contents of the signals at MIC OUT and LINE OUT are the same, the levels are not. LINE OUT level is much higher than MIC OUT level. Be sure you have made the correct connections and carefully monitor the signal levels of each output.

Connect LINE OUT to the input jack of your PA amplifier which is designed to accept a high level input.

MIC OUT is designed to match the low level input jack like mic input of your PA amplifier or tape recorder, if an aux or line input is not available.

THE MUSICAL SPECTRUM

This chart correlates familiar musical instruments with the numerical frequencies that they produce. Given the often talked about musical range of 20 Hz to 20 kHz, it is surprising how low musical fundamentals actually are. (Almost all are under 3,500 Hz.) It should be understood however that if all instruments were perceived only by their fundamental frequency output (black bands), they would all sound alike. It is the harmonics or overtones (gray bands) that give each individual instrument its character or timbre and set it apart from the others.

Interestingly enough, the human ear is more sensitive to some octaves in the musical spectrum than to others. It is tuned more toward the mid-range frequencies where speech and voice communication occur than to the outer octaves of low bass and high musical overtones. As a result, a very small change here will cause a more noticeable effect than a larger change would at the outer edge of the frequency range.

It's easier to understand the different effects of tonal adjustment, when the musical spectrum is arbitrarily divided into five ranges.

The Bass (approx. 20 – 140 Hz) There is little musical material with fundamental frequencies below about 60 Hz; and what is normally perceived as low bass material is actually in the 60 – 140 Hz range. The very lowest frequency controls can be used to enhance output for the few instruments in that range (organ, contrabassoon, etc.) or they can be used to reduce rumble, acoustic feedback and other low frequency aberrations. The 60 Hz control will cause the perceptible changes in "bass response".

Approximate Frequency Ranges for Musical Instruments and Voice

- – Approximate fundamental range (and lower harmonics)
- ▨ – Approximate range of relatively important harmonics (subjective by necessity)

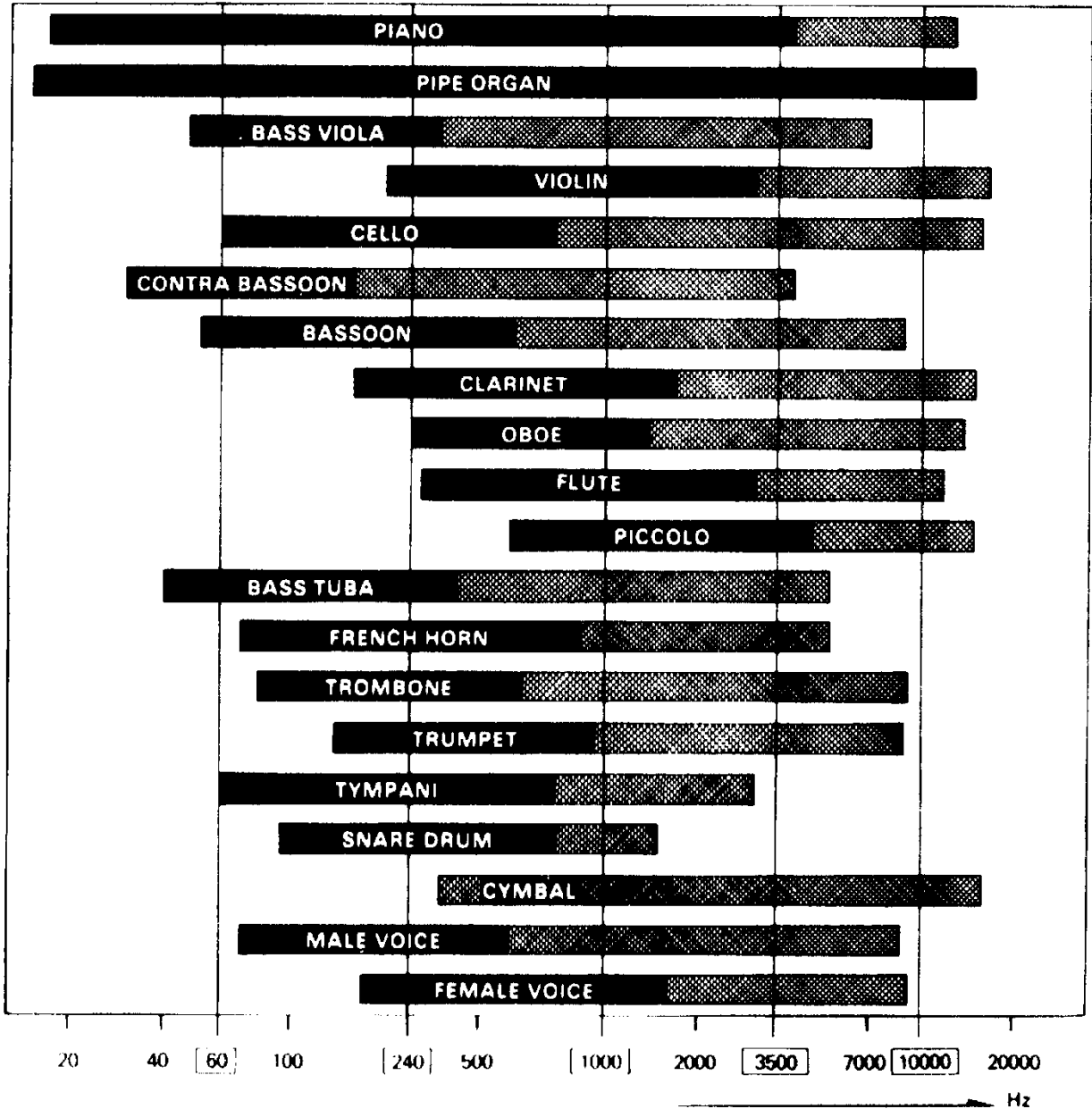

□ = FREQUENCY EQUALIZER CONTROLS

Figure 11

The Mid-Bass (approx. 140 – 400 Hz) An over accentuated mid-bass region will yield a very muddy and “boomy” quality to the music. A system with too little mid-bass will sound hollow and thin. Controls in this region are important for good overall balance.

The Mid-Range (approx. 400 – 2600 Hz) As the area where the ear is most sensitive to tonal balance, the mid-range is important to the adjustment of the qualitative sonic characteristics of your system. There is controversy among engineers and audiophiles as to what the proper balance should be. You will find the appropriate settings vary with different kinds of music.

The Upper Mid-Range (approx. 2600 – 5200 Hz) Speaker designers often boost output in this range to effect a quality of “presence” to the music. Too much energy, on the other hand, sounds overbearingly harsh and strident. A good balance should be achieved between this and a more muffled sound.

The High End (approx. 5200 – 20,000 Hz) The region around 12,000 Hz is normally perceived as the area of high frequencies. Adjustment in this range affects the brilliance of music. But too much boost in energy causes an unpleasant and piercing quality.

The last 8000 Hz contains very little musical material. Most adults have hearing that diminishes rapidly above 13,000 or 15,000 Hz. Consequently, the 10,000 Hz control will have a very subtle effect. It can be used to add a little more dimension to the sound or as a very high frequency noise filter.

SCHEMATIC DIAGRAM

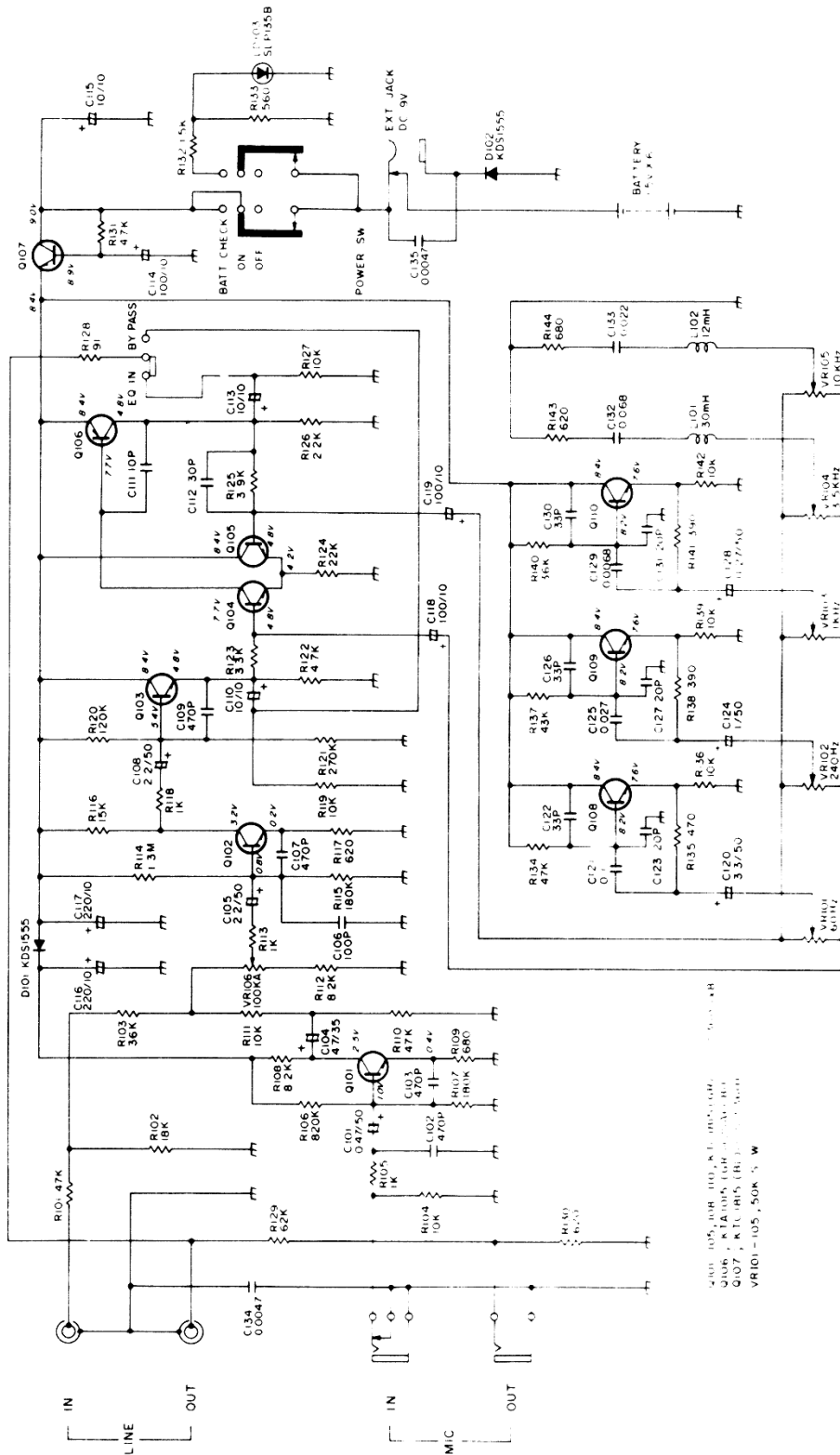

- Notes:**
- (1) ALL RESISTANCE VALUES ARE INDICATED IN OHM
(K = 10^3 OHM, M = 10^6 OHM).
 - (2) ALL CAPACITANCE VALUES ARE INDICATED IN μ F
(pF = 10^{-10} μ F).
 - (3) EQ/BYPASS SWITCH POSITION IS EQ; POWER SWITCH POSITION IS ON.

Schematic subject to change without notice. For most accurate Schematic (and parts) contact Radio Shack, National Parts Dept., Fort Worth, TX 76101

RADIO SHACK LIMITED WARRANTY

This product is warranted against defects for 1 year from date of purchase from Radio Shack company-owned stores and authorized Radio Shack franchisees and dealers. Within this period, we will repair it without charge for parts and labor. Simply **bring your Radio Shack sales slip** as proof of purchase date to any Radio Shack store. Warranty does not cover transportation costs. Nor does it cover a product subjected to misuse or accidental damage.

EXCEPT AS PROVIDED HEREIN, RADIO SHACK MAKES NO WARRANTIES, EXPRESS OR IMPLIED, INCLUDING WARRANTIES OF MERCHANTABILITY AND FITNESS FOR A PARTICULAR PURPOSE. Some states do not permit limitation or exclusion of implied warranties; therefore, the aforesaid limitation(s) or exclusion(s) may not apply to the purchaser.

This warranty gives you specific legal rights and you may also have other rights which vary from state to state.

We Service What We Sell

RADIO SHACK, A DIVISION OF TANDY CORPORATION

**U.S.A.: FORT WORTH, TEXAS 76102
CANADA: BARRIE, ONTARIO L4M 4W5**

TANDY CORPORATION

AUSTRALIA

91 KURRAJONG AVENUE
MOUNT DRUPITT, N.S.W. 2770

BELGIUM

PARC INDUSTRIEL DE NANINNE
5140 NANINNE

U.K.

BILSTON ROAD WEDNESBURY
WEST MIDLANDS WS10 7JN