

SOUND LEVEL METER

OWNER'S
MANUAL

PLEASE READ
BEFORE USING
THIS EQUIPMENT

33-2050

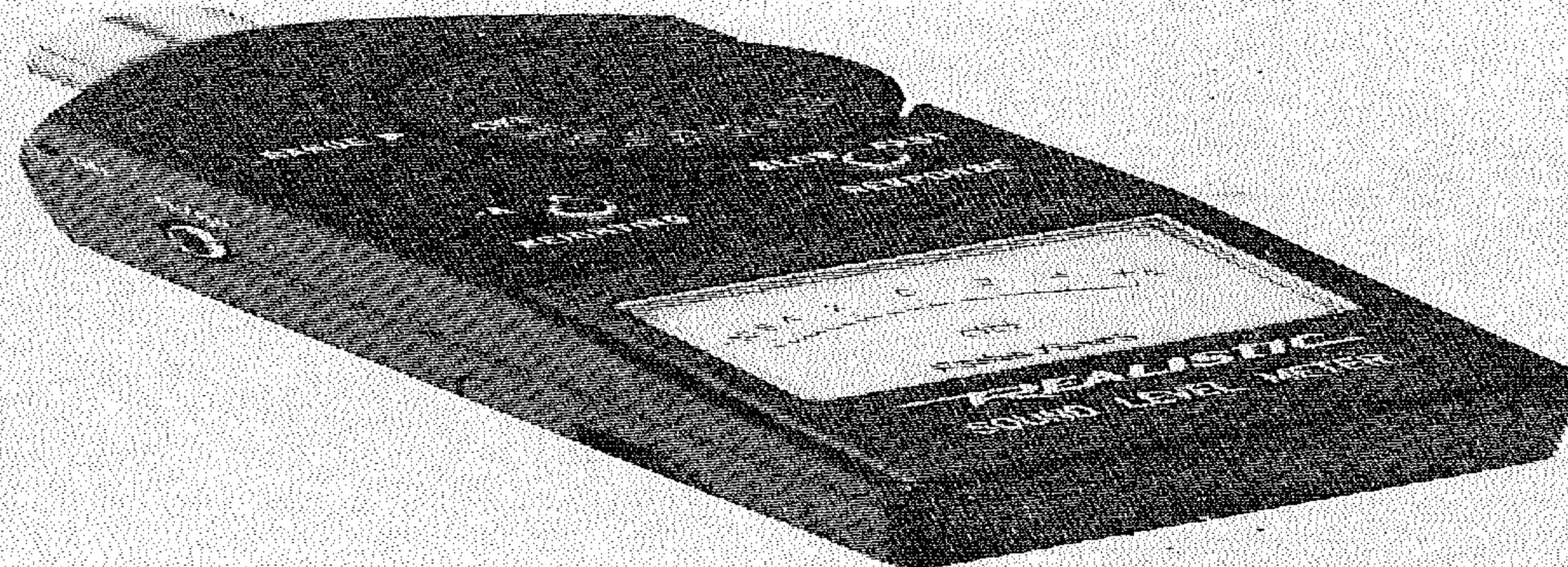

*TRADEMARKS OF
TAYLOR CORPORATION

REALISTIC®*

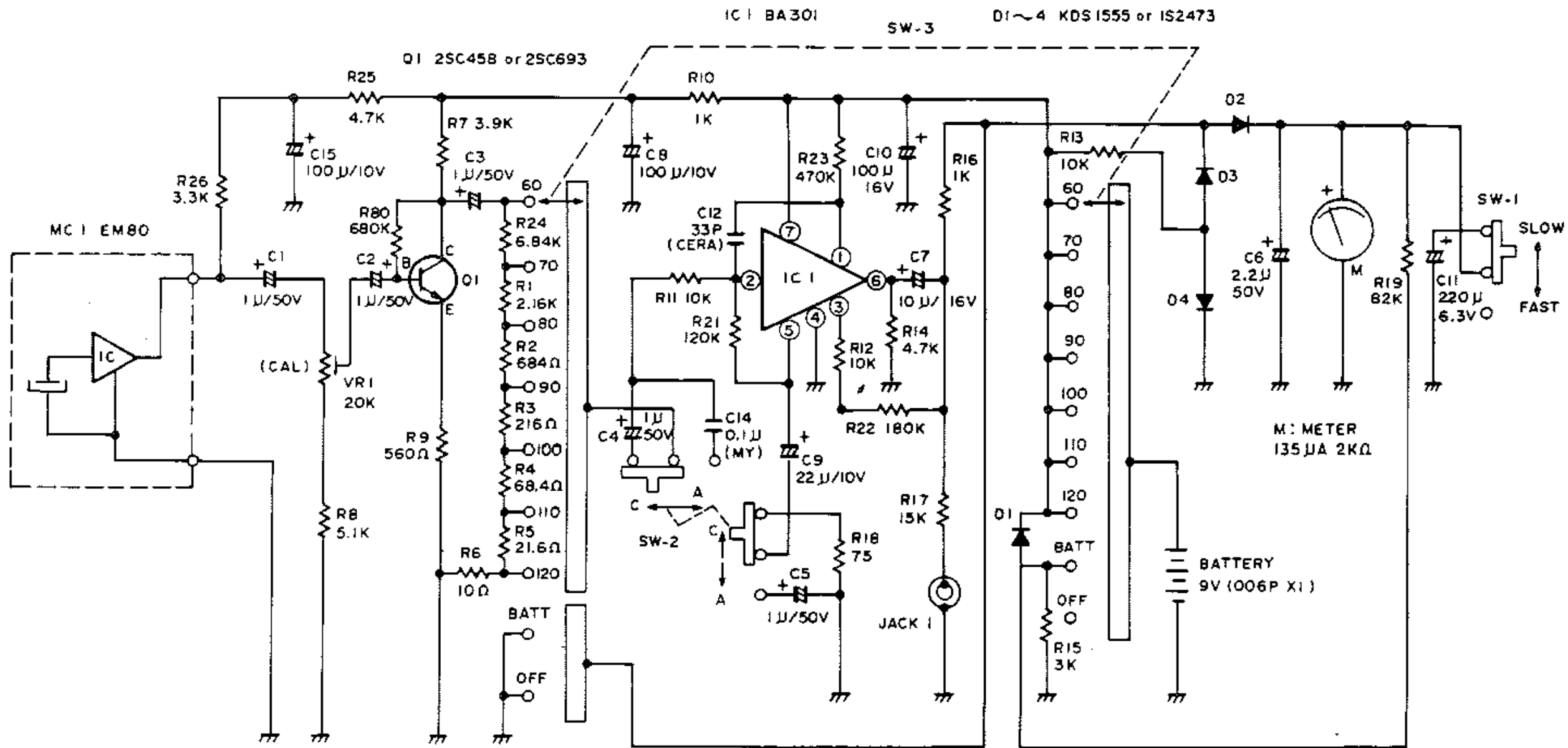

NOTES:

1. ALL RESISTOR VALUES ARE GIVEN IN OHMS.
2. ALL CAPACITOR VALUES ARE GIVEN IN FARAD.

SPECIFICATIONS

Your **REALISTIC**® Sound Level Meter is an extremely versatile device for measuring sound intensity in just about any acoustic environment — loud or soft; high-pitched, low-pitched or broad-band; intermittent or continuous. It has scores of practical applications for professional and home use: measuring noise levels in factories, schools, offices, airports, etc.; checking acoustics of studios, auditoriums and home hi-fi installations.

The precisely calibrated meter features a large, easy-to-read indicator for taking quick measurements anywhere. Power is supplied by a 9-volt rectangular battery, so the unit is completely portable.

Other exceptional features of the Sound Level Meter:

- Seven sound-level ranges, allowing measurements from 50 dB to 126 dB (referred to 0.0002 μ bar)
- A and C weightings for checking compliance with safety regulations as well as making acoustic analyses
- SLOW and FAST response settings for checking peak and average noise levels
- Built-in battery condition indicator
- Phono-type output jack for connection to hi-fi or test equipment
- Threaded insert for attachment of meter to camera tripod for increased accuracy

Ranges:	Range of measurement
Switch setting	
60 dB	50 to 66 dB
70 dB	60 to 76 dB
80 dB	70 to 86 dB
90 dB	80 to 96 dB
100 dB	90 to 106 dB
110 dB	100 to 116 dB
120 dB	110 to 126 dB
Accuracy	: ± 2 dB at 114 dB sound level
Standard	: 0 dB = 0.0002 μ bar
Weighting	: A and C (see graph, Figure 2)
Response	: FAST and SLOW
Signal Output	: 1.0 volt (peak) minimum into open circuit, with full-scale meter deflection at 1 kHz
Load Impedance	: 10 kohms minimum
Distortion	: Less than 2% at 1 kHz, 0.5-volt

Microphone	: Electret condenser; omnidirectional becoming slightly directional with increase in frequency (see graph, Figure 3)
Battery	: One 9-volt rectangular type
Battery Check	: Tests "good" from 7.0 to 10.5 volts
Expected Battery Life	: 110 working hours, alkaline battery
Size	: 6-1/4" (H) x 2-7/16" (W) x 1-3/4" (D) (160 x 62 x 44mm)
Weight	: 6.6 ounces (185 grams) approx.

CONTROLS AND THEIR FUNCTIONS

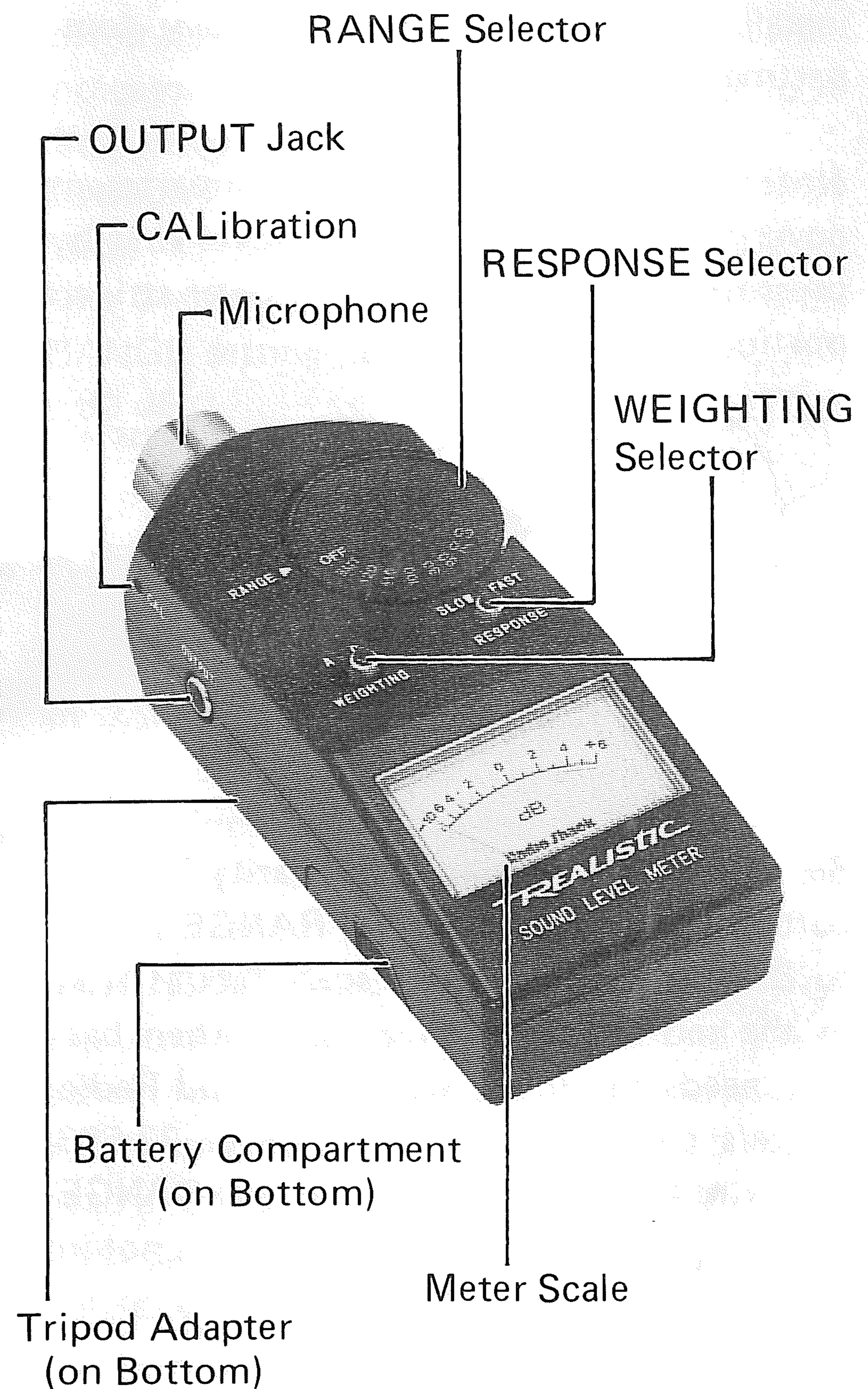
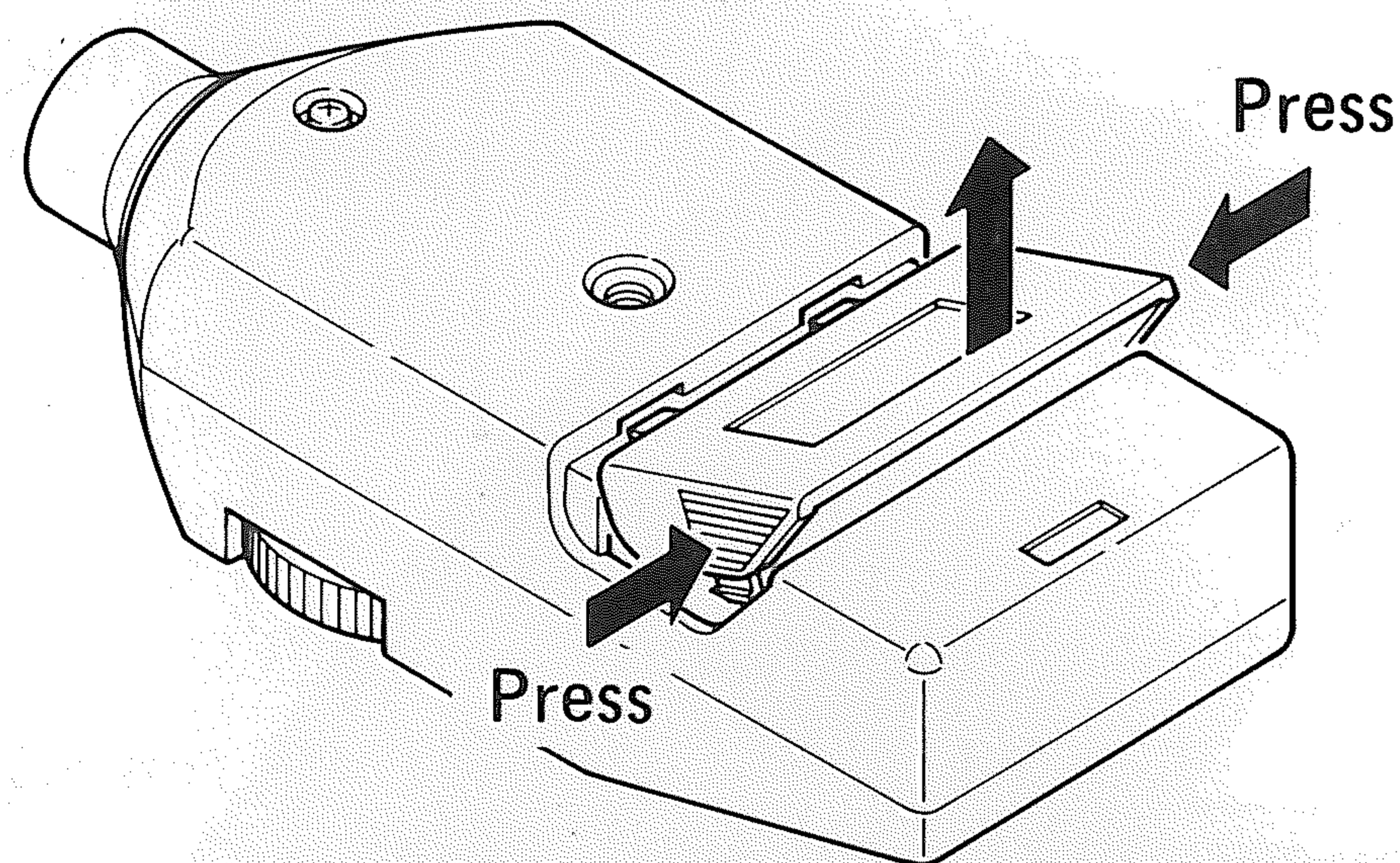

Figure 1.

Battery Compartment

Flip open battery compartment cover and install a 9-volt battery in the battery compartment.

Note: To open the battery compartment cover, lift the bottom of the cover first by pressing the both sides at the lower striped portion.



Be sure to observe proper polarity. Check battery condition by setting RANGE switch to BATT position; meter scale should read in the red BATT TEST region. When battery needs replacing, we recommend Radio Shack's catalog number 23-583, or 23-553 for extra-long life. Be sure to leave RANGE switch in OFF position when Meter is not in use, and remove battery if Meter is to be stored for a long period.

RANGE Selector

The rotary switch lets you select one of seven

sound level ranges, each spanning 16 dB. Numbers on the RANGE switch refer to the center-points of the seven ranges. The needle indicator shows the actual sound level as a displacement from the center-point.

Examples: Suppose RANGE is set to 80, and meter scale reads -3 . Actual sound level is $80 - 3 = 77$ dB. If meter scale reads 0 (same RANGE setting), actual sound level is $80 + 0 = 80$ dB.

RESPONSE Selector

In FAST position, Meter will react quickly to changes in sound level, giving you an indication of peak sound levels present in the environment. In SLOW position, Meter is damped and indicates an average-value sound level. The effect of brief sound peaks is minimized in this position.

WEIGHTING Selector

The frequency response of the Sound Level Meter for each weighting characteristic is shown in Figure 2. The C-weighting curve is nearly uniform over the frequency range from 32 to 10,000 Hz, thus giving an indication of overall sound level. The A-weighting characteristic responds primarily to frequencies in the 500-to-10,000 Hz range, which is the area of greatest sensitivity of the human ear.

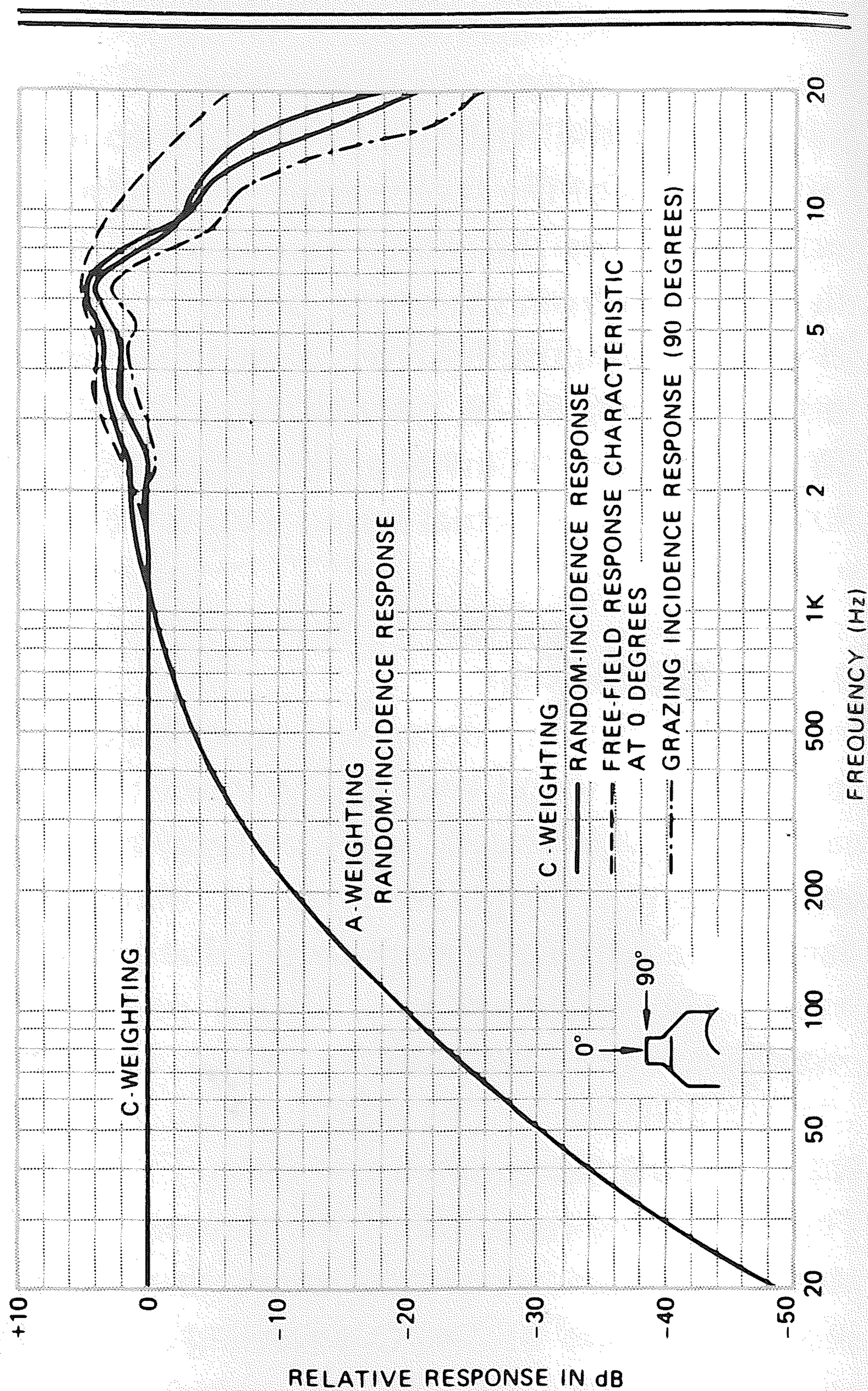

Figure 2. Typical A- and C-weighted response curves of Sound Level Meter (A-weighted with random-incidence).

OUTPUT Jack

The phono-type output jack lets you connect the unit to recording or other measurement equipment. For example, you might connect it via an audio patch cord to the aux, or high level input of a recorder. Note that the meter response will not be flat, due to the A and C weighting networks. Set the RANGE selector so that maximum needle deflection is *never greater than +4*, to prevent the built-in amplifier from clipping. Use A-weighting for voice recordings, or C-weighting for full-range musical material. The OUTPUT jack may also be connected to high-impedance headphones, oscilloscope, frequency analyzer or other test equipment.

Tripod Adapter

You can mount the Sound Level Meter on a camera tripod (standard 1/4-20 thread) to eliminate hand noise and minimize the effects of sound reflected from your body. A tripod mount is also convenient for using the Meter with auxiliary recording or testing equipment.

CALibration

The Sound Level Meter has been accurately calibrated at our factory, and normally will not require further adjustment. Special equipment, including a sound generator, is required for calibration. The hole provides access, however, unless you are qualified, we suggest such adjustments be left to your Radio Shack service technician.

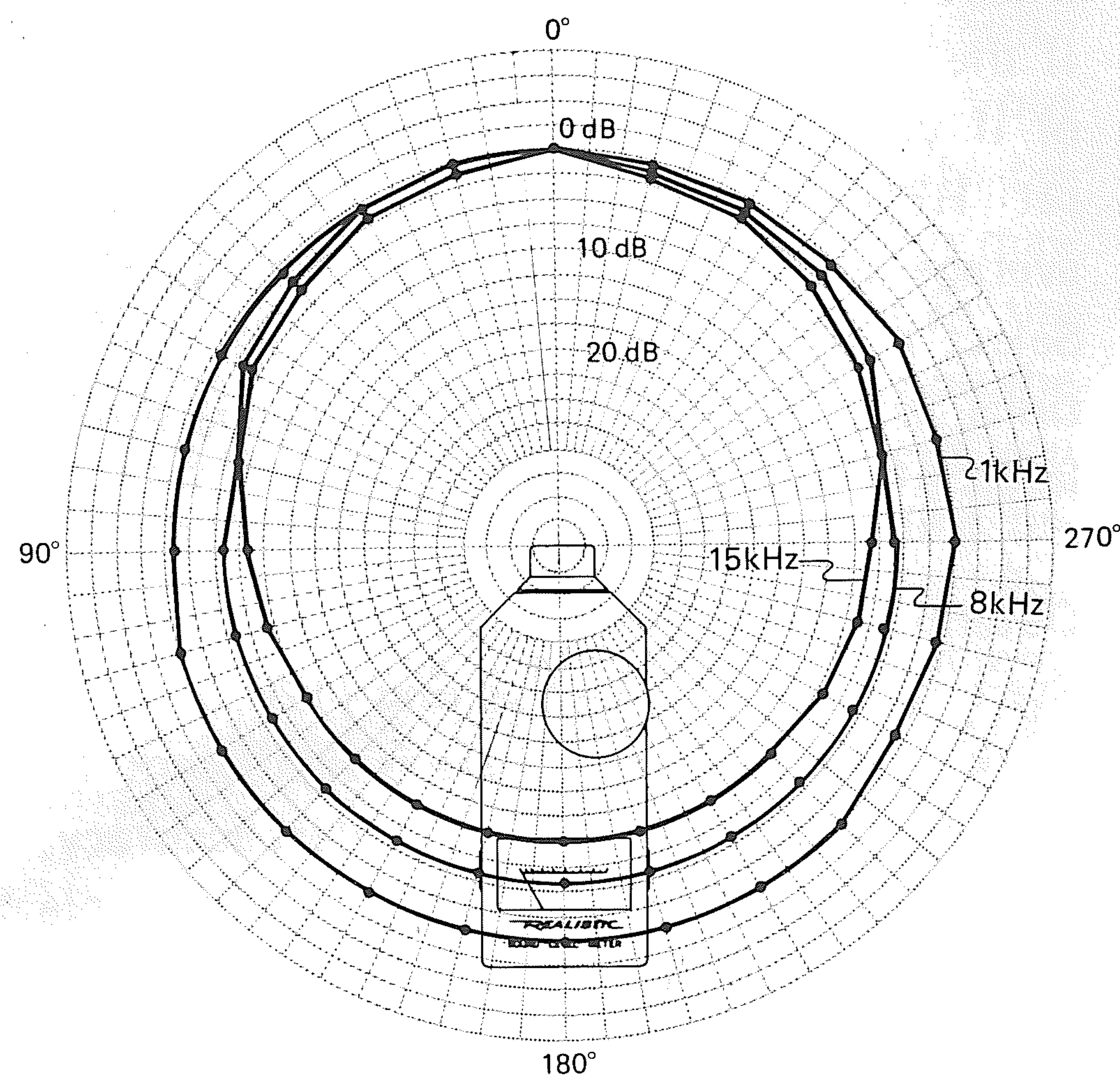

Figure 3. Polar response of the built-in microphone. Note that best response is obtained when you point the microphone at the source.

MAKING ACCURATE MEASUREMENTS

Select the desired Response and Weighting.

If the sound source consists of short bursts, or if you're interested in peak values only, set RESPONSE to FAST. To measure average sound levels, use the SLOW setting. Select A-weighting for noise-level determinations, and C-weighting for measuring sound levels of musical material.

Determine the appropriate Range setting.

Start with the highest setting (120 dB) and work downward until there is significant deflection of the needle. For greatest accuracy, always use the lower of any two possible settings. Example: If RANGE is set to 80 dB and meter reads around -5, reset RANGE to 70 dB and meter will read +3, for an actual sound level of 73 dB.

Important Note: For meaningful readings, any particular sound to be measured should be at least 10 dB louder than the background noise level.

Minimize the effect of your body's presence. When the sound is coming mainly from one direction, the level reading may be significantly affected by reflections from your body. Do not hold the Meter directly between you and the sound source, as this may produce an error of several decibels in the frequency range above 100 Hz. Position the Meter so that an imaginary line between you and the Meter is perpendicular to a line between the Meter and the sound source. For the most accurate readings, point the microphone towards the sound source when possible.

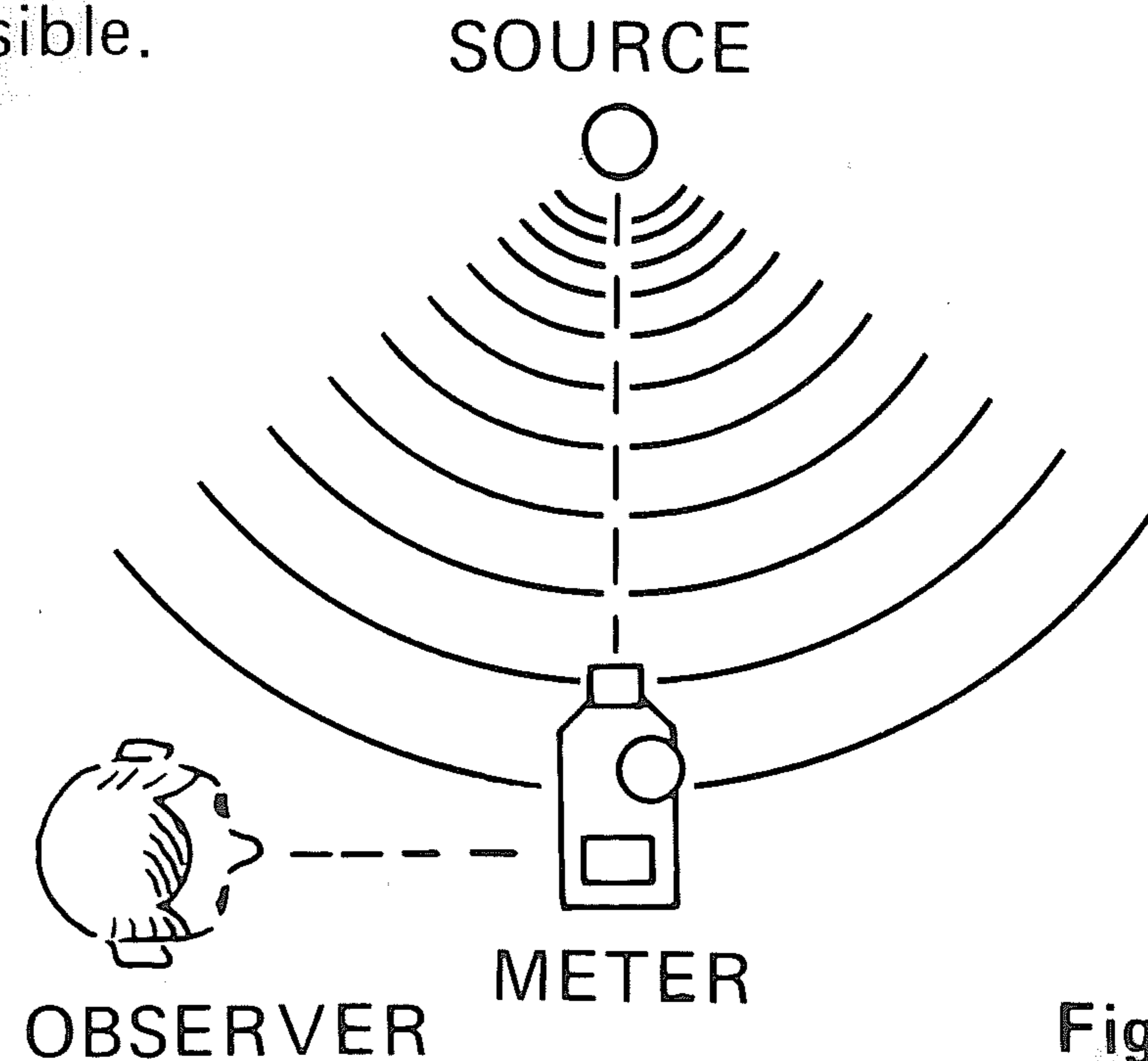

Figure 4.

Handle the Meter carefully.

The microphone and meter movement are fragile and may be damaged if the instrument is dropped. Don't operate the Meter at a range setting that causes "pegging" of the needle. This could damage the movement.

CHECKING NOISE LEVELS

Noise is an important aspect of any environment — home, office, factory, school or recreation area. As Figure 5 illustrates, every one of us is exposed to a tremendous range of noise levels, no matter where we go or what we do.

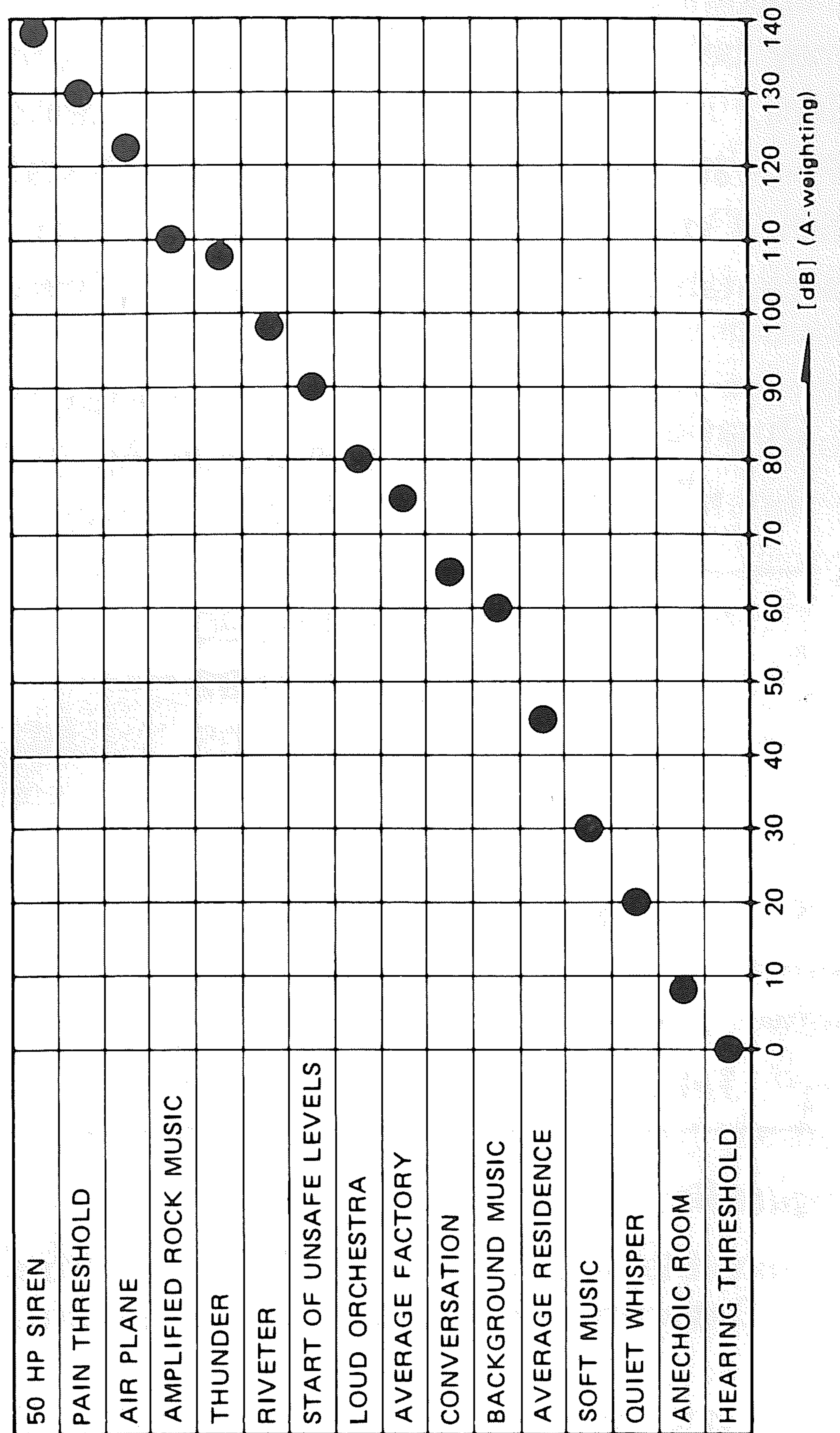

Typical sound levels.

Depending on the level and duration, noise may be a minor irritant, a definite disturbance, or even a threat to your hearing. Federal, state and local agencies have established standards for just how much noise is acceptable. Figure 6 gives one such standard.

Duration per day, hours	Sound level (dB), A-weighting, SLOW response
8	90
6	92
4	95
3	97
2	100
1-1/2	102
1	105
1/2	110
1/4 or less	115

Figure 6.

Permissible noise exposures. Extracted from U.S. Department of Labor noise regulations.

To check noise levels with the Sound Level Meter, use A-weighting with SLOW response. Take measurements at several points in the test area, with the Meter positioned as indicated in Figure 4.

CHECKING HI-FI ACOUSTICS

The size, shape and furnishings of a room can have a tremendous effect on a hi-fi system's performance. A "hard" room with bare surfaces tends to exaggerate treble response, sometimes giving the music a strident quality. A "soft" room with curtains, overstuffed furniture, carpet, etc., may reduce high-frequency response so the bass sounds dominant, giving you a "mushy" sound. Depending on speaker placement, standing waves may also develop in the room, giving your system a peaky, eccentric response.

The first step in solving this problem is to analyze the room's acoustics with your Sound Level Meter and a suitable test record. The test record should produce pure tones, one at a time, at intervals spanning the audio spectrum. Make a graph or table showing the sound levels generated by the individual tones. This gives you a clear idea of the frequency response of your "total system" — hi-fi equipment and room included.

The next step is to smooth out the response. Adjusting tone controls and varying speaker placement may improve things significantly. But to approximate the ideal "flat response", you should add a frequency equalizer to your hi-fi system. We recommend the use of one of our frequency equalizers. These components let you boost or cut response in different ranges, as called for by your frequency response analysis. Properly equalized, your system can sound like one costing considerably more!

Note: With C-weighting, the Sound Level Meter's frequency response is flat from 32 to 10,000 Hz (± 3 dB). Above 10 kHz, the frequency response of the Sound Level Meter drops off rather rapidly: be sure to take this into account when using a test record which includes tones at the extreme high end of the audio spectrum.

SCHEMATIC DIAGRAM

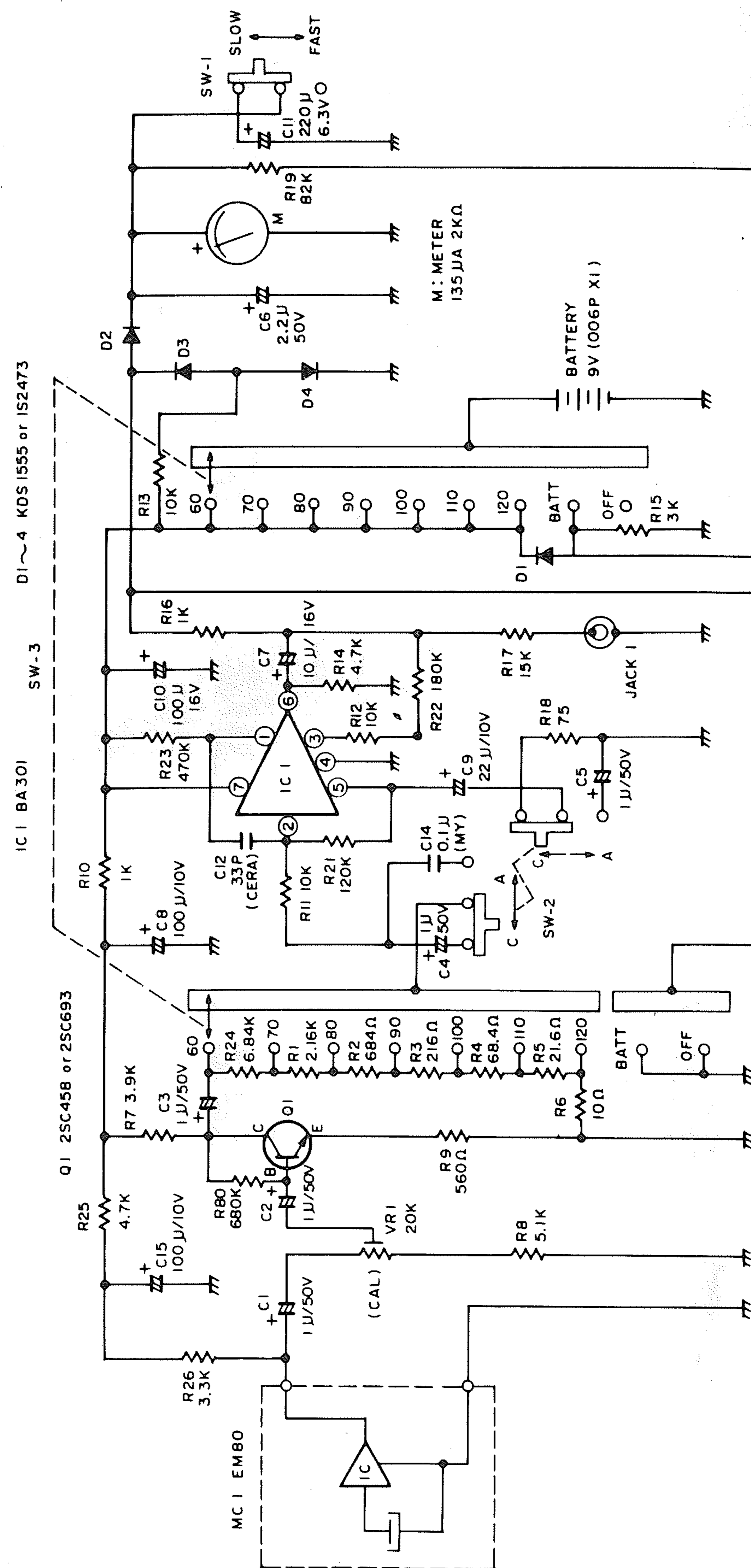

NOTES:
1. ALL RESISTOR VALUES ARE GIVEN IN OHMS.
2. ALL CAPACITOR VALUES ARE GIVEN IN FARAD.



RADIO SHACK LIMITED WARRANTY

This product is warranted against defects for ninety (90) days from the date of purchase from Radio Shack company-owned stores and authorized Radio Shack dealers. Within this period Radio Shack will repair the product without charge for parts and labour. Simply **bring your Radio Shack sales slip as proof-of-purchase** date to any Radio Shack store. Warranty does not cover transportation costs. Nor does it cover a product subjected to misuse or accidental damage.

EXCEPT AS PROVIDED HEREIN, RADIO SHACK MAKES NO WARRANTIES, EXPRESS OR IMPLIED, INCLUDING WARRANTIES OF MERCHANTABILITY AND FITNESS FOR A PARTICULAR PURPOSE.

This warranty gives you specific legal rights and you may have other rights which vary from province to province.

WE SERVICE WHAT WE SELL

**CUSTOM MANUFACTURED FOR
RADIO SHACK DIVISION, InterTAN CANADA LTD.
BARRIE, ONTARIO. L4M 4W5**