

REALISTIC<sup>®</sup>

# Service Manual

42-2970

LAB-500

**QUARTZ LOCK DIRECT-DRIVE  
TURNTABLE**

**WITH FULL-AUTOMATIC SYSTEM**

**CATALOG NUMBER:42-2970**



8A8 003091

Purchased 7/21/79

CUSTOM MANUFACTURED FOR RADIO SHACK  A DIVISION OF TANDY CORPORATION

## TABLE OF CONTENTS

TECHNICAL SPECIFICATIONS .....	3
ADJUSTMENTS .....	4
DISASSEMBLY INSTRUCTIONS .....	7
TROUBLESHOOTING .....	9
MECHANISM OPERATING PRINCIPLE .....	13
DESCRIPTION OF SERVO CIRCUIT .....	16
PRINTED CIRCUIT BOARD .....	18
SCHEMATIC DIAGRAM .....	19
WIRING .....	20
EXPLODED VIEW .....	21
PARTS LIST .....	22

## TECHNICAL SPECIFICATIONS

Description	Condition	Nominal	Limit
Type		2-speed QUARTZ Locked DIRECT drive, full automation system	
Platter		Aluminum alloy die-cast, 12-5/8" (320 mm) outer diameter, 3.1 lbs (1.4 kg)	
Motor		12-pole brushless DC QUARTZ-locked servo-type	
Speed	Measured with 3 kHz reference signal	2-speed: 33-1/3 rpm 45 rpm	34.0 ~ 32.7 44.1 ~ 45.9
Speed Accuracy		0.0005% after 1.5 second	
S/N	Measured at 1 kHz, 5 cm/sec	Better than 55 dB(IEC B)	
Rumble (DIN B)		70dB	
Wow & Flutter	Measured at 3 kHz	Less than 0.04% (WRMS)	0.06% (WRMS)
Tone arm		Static balance type, tubular Plug-in type	
Head shell & Cartridge		12-3/8" (315 mm)	
Overall length		8-15/16" (227 mm)	
Effective length		9/16" (14mm)	
Overhang		0 to 3g/one of the scale ring (directly readable in 0.1g steps)	
Adjustable force range (scale)		4.5 to 10g	
Acceptable cartridge weight			
Effective arm mass		19.8g	
Resonance of arm and and Cartridge		7.5Hz	
Tracking error		+2° 54" -1° 30"	
Cartridge		Realistic/Shure Model R-9000ELWS	
Frequency response		20 ~ 20,000 Hz	
Output voltage		3. mV at 1 kHz, 50 mm/sec	
Channel difference		2 dB at 1 kHz	
Channel separation		23 dB at 1 kHz	
Tracking force		3/4 ~ 1-1/2 grams	
Stylus tip		0.7 × 0.2 mil diamond stylus	
Measured compliance		30 × 10 <sup>-6</sup> cm/dyne	
Nominal DC resistance		1550ohms typical	
Nominal inductance		650mili henries	
Recommendeb termination		47Kohms, 450pF	
Stylus pullout force		6-25oz (170-700g)	
Cartridge weight		10.7 grams	
Power source		120 volts, 60 Hz AC 220/240 volts, 50 Hz for European/Australian Models	
Power consumption		8 watts	
Dimension		6-1/8" (H) × 18-7/8" (W) × 15-3/16" (D)	
Weight		22 lbs (10 kg)	
ACCESSORIES		Counterweight 45 RPM adapter	

NOTE: Nominal Specs represent the design specs; all units should be able to approximate these — some will exceed and some may drop slightly below these specs. Limit Specs represent the absolute worst condition which still might be considered acceptable; in no case should a unit perform to less than within any Limit Spec.

## ADJUSTMENTS

### 1. Tracking Force Adjustment

Caution: During adjustment, be careful not to let the stylus tip touch the Plate or Turntable Mat.

- (1) After removing the Stylus Cover from the Cartridge, bring the Tone Arm to a position halfway between the Arm Rest and Plate.
- (2) Turn the Counterweight to balance the Tone Arm, and let the Tone Arm rest on the Arm Rest. (Fig. 1)
- (3) Fix the Counterweight so that it will not move. Turn just the Tracking Force Scale Knob to set "0" to the Tone Arm's index mark.
- (4) Turn the Counterweight gently counterclockwise to set the Knob's scale to the tracking force specified for the cartridge. The recommended tracking force for the cartridge supplied is 1-1/2g.

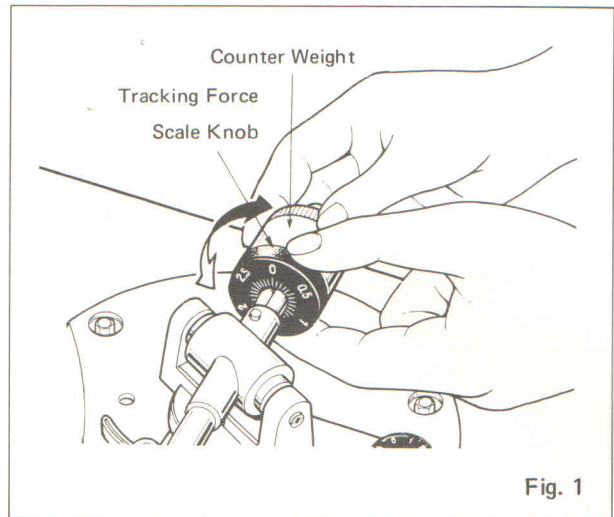

### 2. Stylus Tip Height Adjustment

- (1) The stylus tip height decreases as the Stylus Tip Height Adjust Screw is turned clockwise and increases when turned counterclockwise. (Fig. 2)
- (2) The optimal stylus tip height is 9 mm measured from the Turntable Mat to the Stylus Tip (when CUE is in UP position).

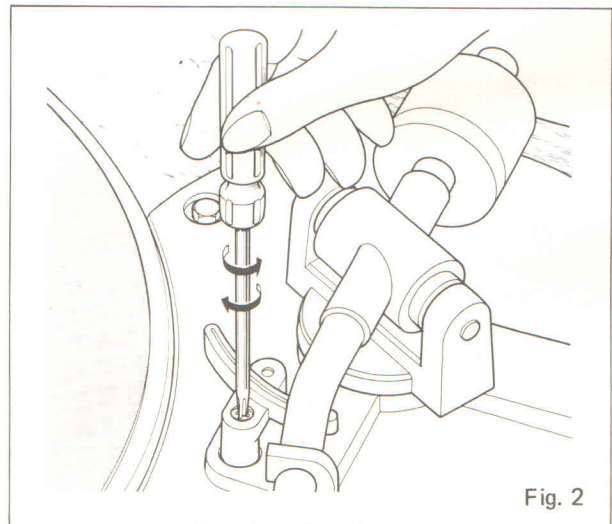

### 3. Adjustment of Antiskate Mechanism

In tone arms having an offset angle, a force is generated during record playing that causes the stylus tip to be pulled toward the record center, resulting in improper tracking and/or jumping of stylus. The antiskate mechanism applies a force that corresponds to the tracking force. When the tracking force is 1-1/2g, the scale of the antiskate knob should also be set to 1-1/2. (Fig. 3)

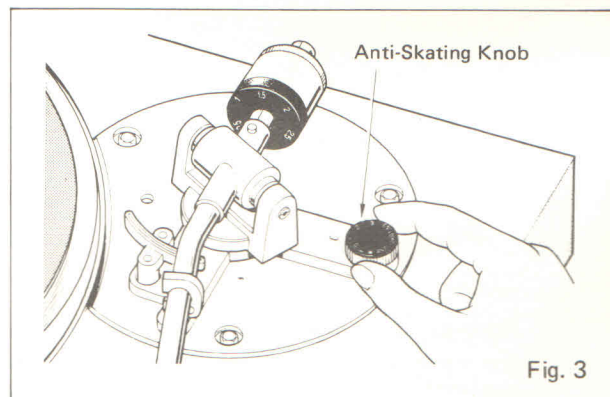

#### 4. LEAD-IN Adjustment

- (1) If at LEAD-IN, the stylus tip descends outside the lead-in groove, correct this by turning the LEAD-IN Adjust Screw clockwise. (See Figs. 4 & 5.)
- (2) If at LEAD-IN, the stylus tip descends to a position inside the proper LEAD-IN position, correct by turning the Lead-In Adjust Screw counterclockwise.

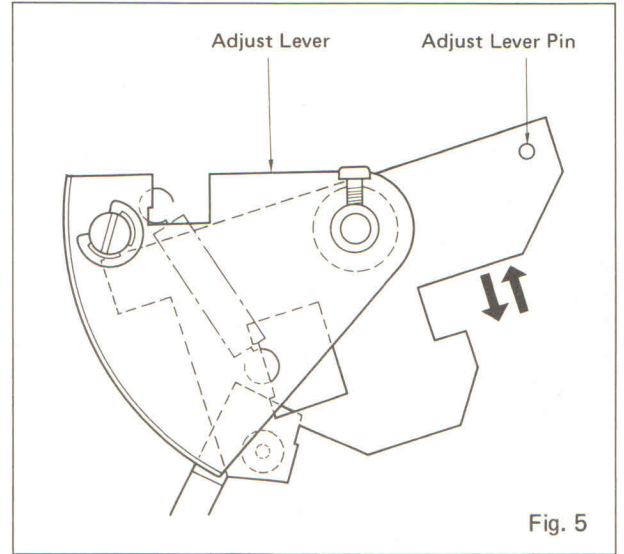
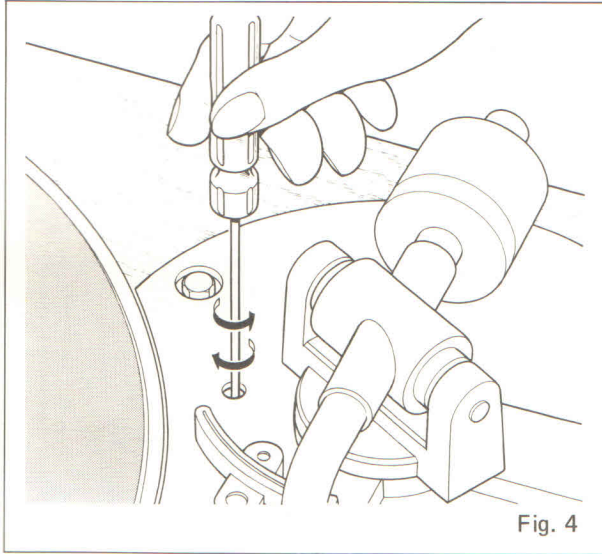

#### 5. LEAD-OUT Adjustment

If the Tone Arm does not lift off when the stylus tracks in the "Lead-Out" groove, or has lifted off before the lead-out groove, adjust as follows:

- (1) Turn Lead-Out Adjust Screw to "Lead-Out" sooner; turn counterclockwise to lead-out later. (Fig. 6)

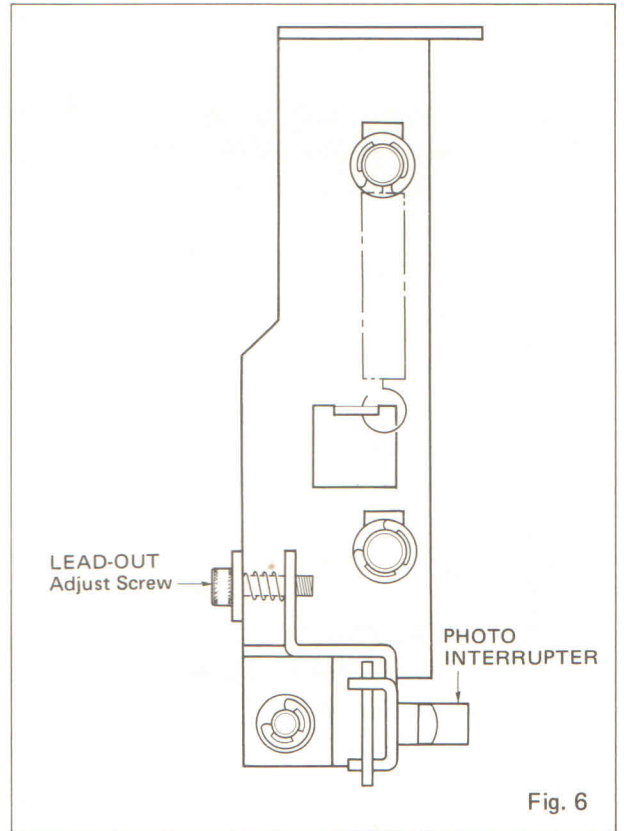

## 6. Phase Adjustment of Servo Circuit

**IMPORTANT:** For adjusting, a dual-trace oscilloscope is required. If you don't have one, do NOT adjust the VR's but replace entire Servo PCB assy.

### (1) Test instruments required

- 1) Dual trace Oscilloscope
- 2) 24V DC Power Supply

When adjusting only the servo circuit board assembly, a regulated DC power supply is needed.

### (2) Connection

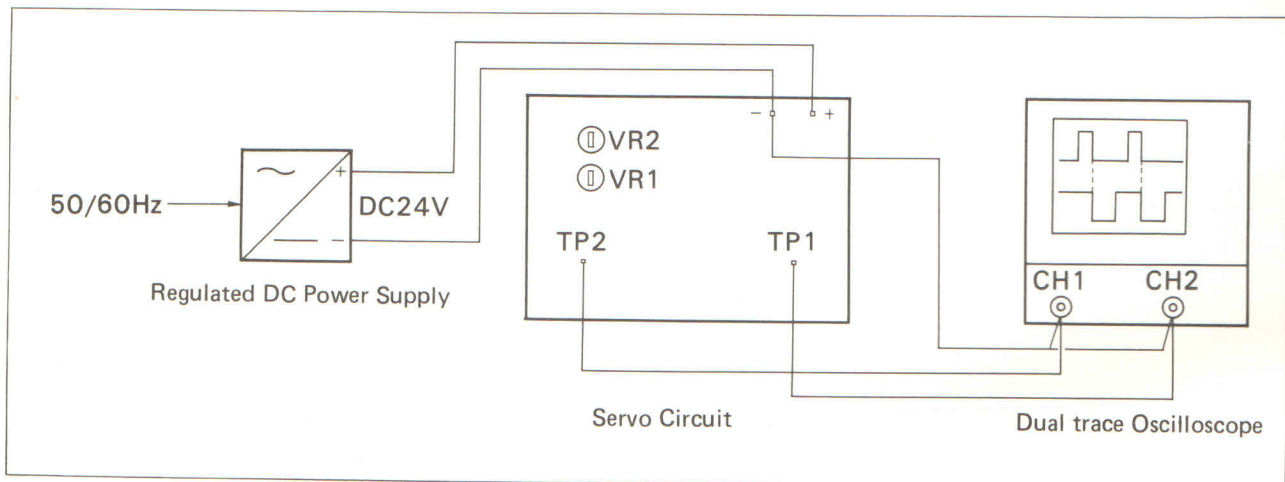

### (3) Adjustment

- 1) Set Motor speed to 45 rpm and apply power. Then, by turning VR1, synchronize the negative-edge phase as shown in the drawing.

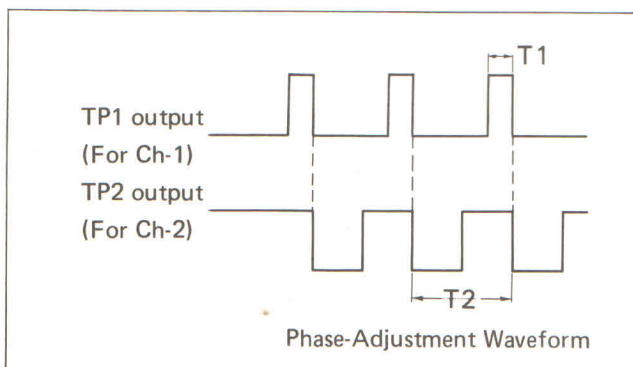

T1..... 0.8 ~ 1.2ms  
 T2..... 20ms at 33-1/3 rpm  
 14.814ms at 45 rpm

- 2) Next, set speed to 33-1/2 rpm and adjust VR2 in the same manner.

**CAUTION:** (1) Always perform 45 rpm adjustment first.

- (2) The adjustment must be very precise.

## DISASSEMBLY INSTRUCTIONS

### 1. Removal of Motor

- (1) To Remove Rear Cover.  
Turn the set upside down and remove the rear cover screws (ten 3.1 x 20 screws and two M3 x 8 screws). Take off Rear Cover.
- (2) Remove the three motor screws (M3 x 8). (Fig. 7)
- (3) If only the Motor is to be removed, disconnect plug from the Servo Circuit Board.
- (4) To remove the Servo Circuit Board together with the Motor, pinch the end of the plastic standoffs with pliers (Fig. 8) and lift off the Servo Circuit Board.

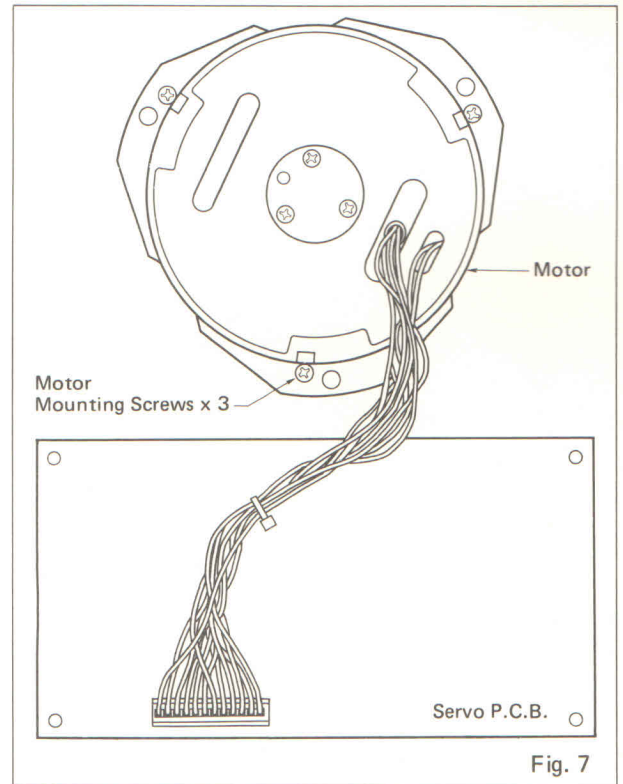

### 2. Removal of Tone Arm

- (1) Remove Rear Cover.
- (2) Turn the Center Shaft of the Start/Stop Lever, until the pin on the forward end of the Drive Lever reaches a position off the Holder. (Fig. 9)

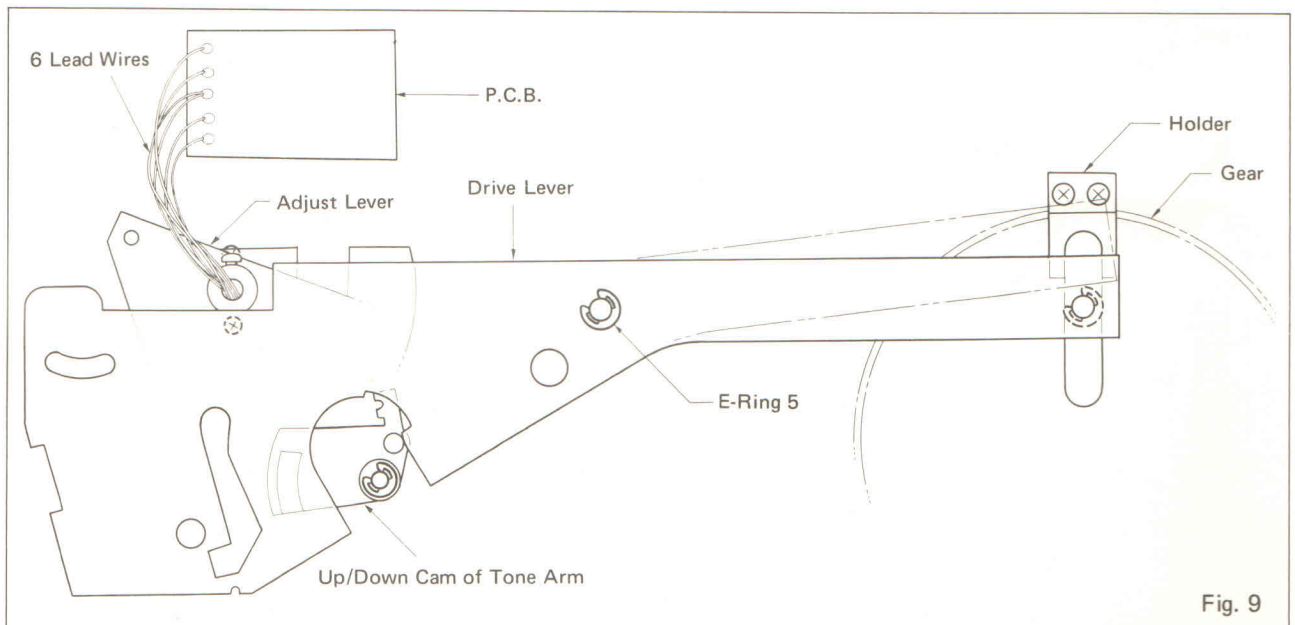
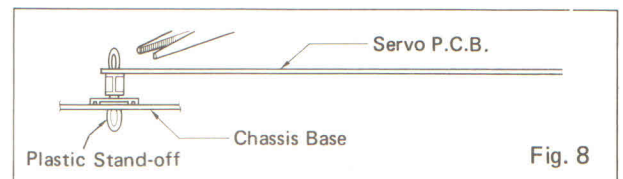

- (3) Remove Drive Lever.
- (4) Unsolder the output leads of the Tone Arm.
- (5) Remove the Up/Down Cam of the Tone Arm (E-Ring).
- (6) Remove the Arm Lever (Adjust Lever).
- (7) Remove two screws (M3 x 5) from the Tone Arm and lift off the Tone Arm. (Fig. 10)

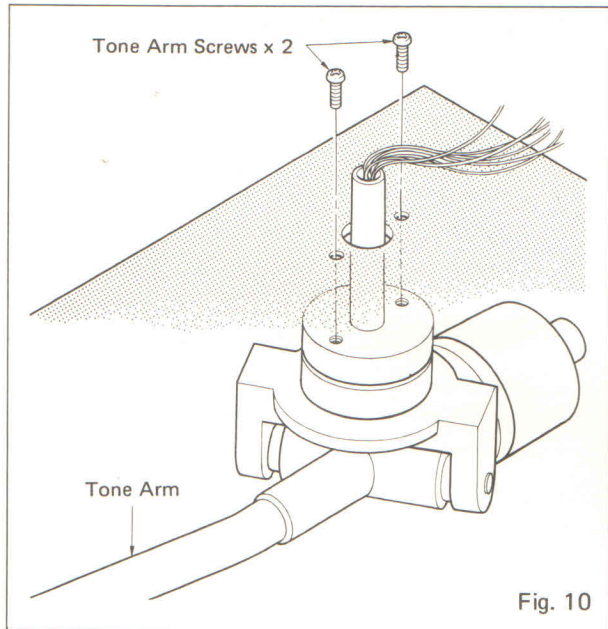

### 3. Removal of Arm Lifter

- (1) Take off Rear Cover.
- (2) Remove the nut shown in Fig. 11.  
Remove the Shaft Assy of the Arm Lifter.

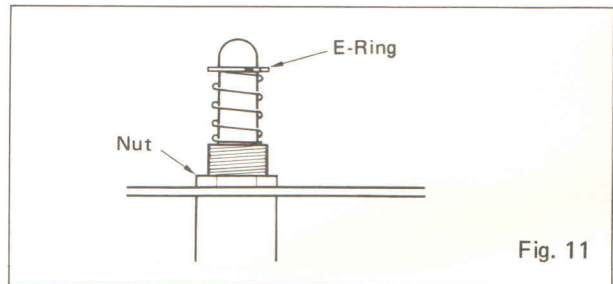

### 4. Removal of Trim and Arm Rest

- (1) After the Arm Lifter has been removed as described above, remove three hexagon bolts (M3 x 12).  
The Trim can now be removed along with the Arm Rest.

Note: Since the Trim is glued in place, it can not be removed just by removing the hexagon bolts.

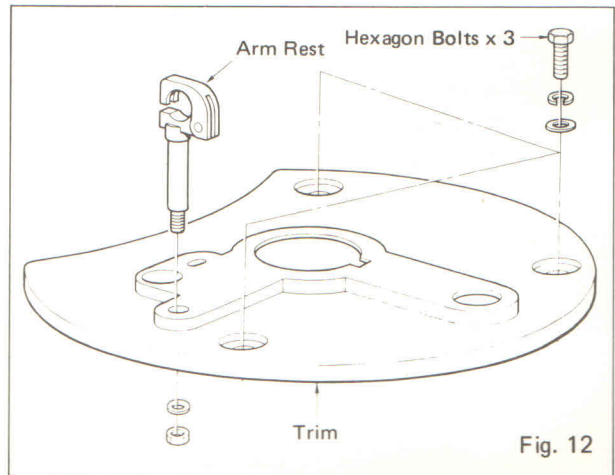



## TROUBLESHOOTING

### I. No Sound is Heard.

1. Touch the plus side of the Cartridge Chip with your finger and check whether any sound is heard.
  - YES: Defective cartridge  
 Note: Check with ohmmeter.  
 The DC resistance of the Moving Magnet type is in the range from several hundred ohms to several kilo-ohms.  
 Insufficient contact of cartridge terminal with Connector pins.
  - NO: Detach the cartridge from the tone arm, and touch the hot side of tone arm's neck section to check for a sound output. (Fig. 13)  
 Note: Do not set Amplifier/Receiver's volume too high when making this type of test.
    - YES: Inferior cartridge
    - NO: Check continuity between Cartridge pin and the Pin jack of the Output Cords.
      - OPEN: Insufficient contact of Tone Arm's neck section. (Fig. 14)  
 Disconnection between Cartridge Pin and Pin Jack of Output Cord. Check continuity. (Fig. 15)
      - "0" OHM: Short-circuit between Cartridge Pin and Output Cords.

2. Check and confirm that the muting circuits (Microswitches S102 and 104) are operating normally.

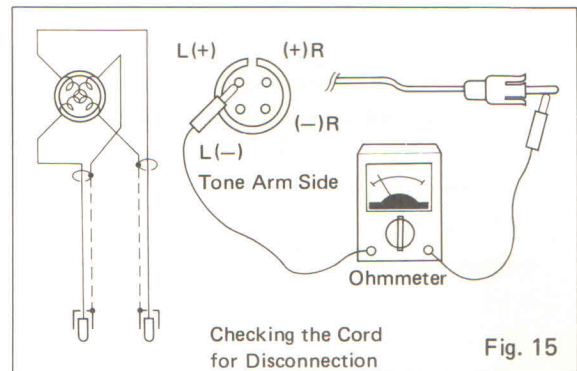
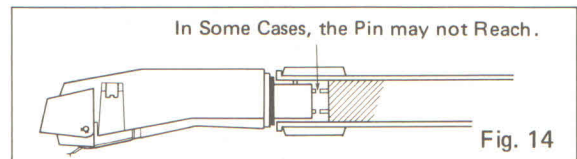
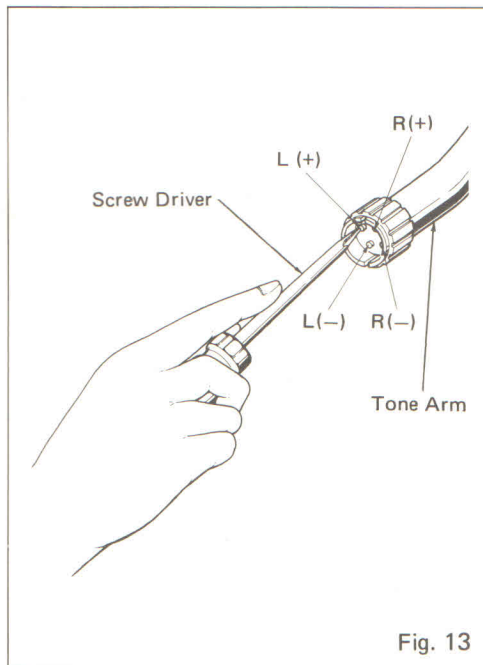

### II. Distorted Sound

[Possible Causes]

- (a) Inadequate tracking force
- (b) Dust on stylus tip
- (c) Worn stylus tip
- (d) Defective cartridge
- (e) Slanting of head shell. Loosening of neck section of head shell.
- (f) Others

Is the tracking force adequate? Check tracking force and stylus tip.

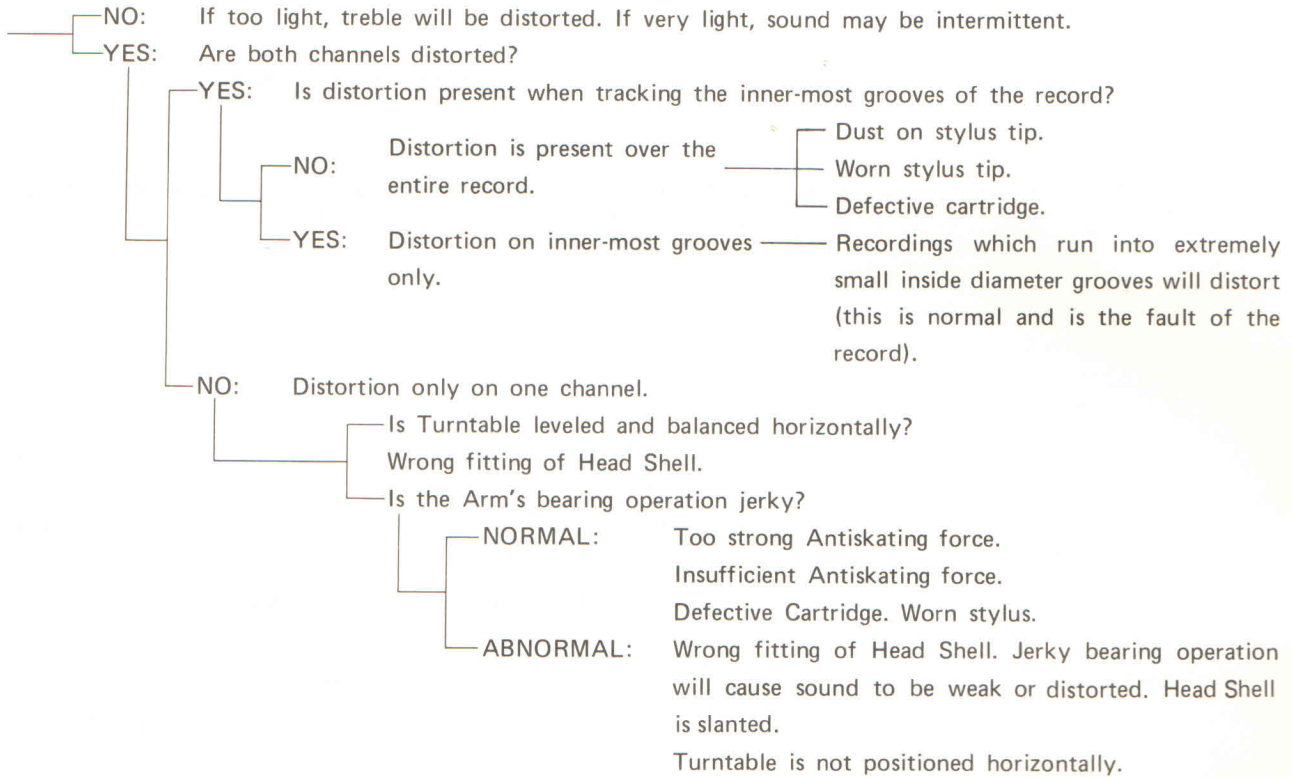

### III. Intermittent Sound

[Possible Causes]

- Interruption of sound when someone walks by the Turntable is caused by a too-light tracking force, or by vibrations that cause the stylus to jump.
- Intermittent Cartridge Coil.
- Intermittent wiring somewhere between Cartridge and Preamplifier's PHONO Terminal Pin Jack, or intermittent short-circuit in that area.
- Insufficient contact, or defective soldering of pin jacks.

When in the PLAY mode, is sound interrupted when someone walks by the Turntable?

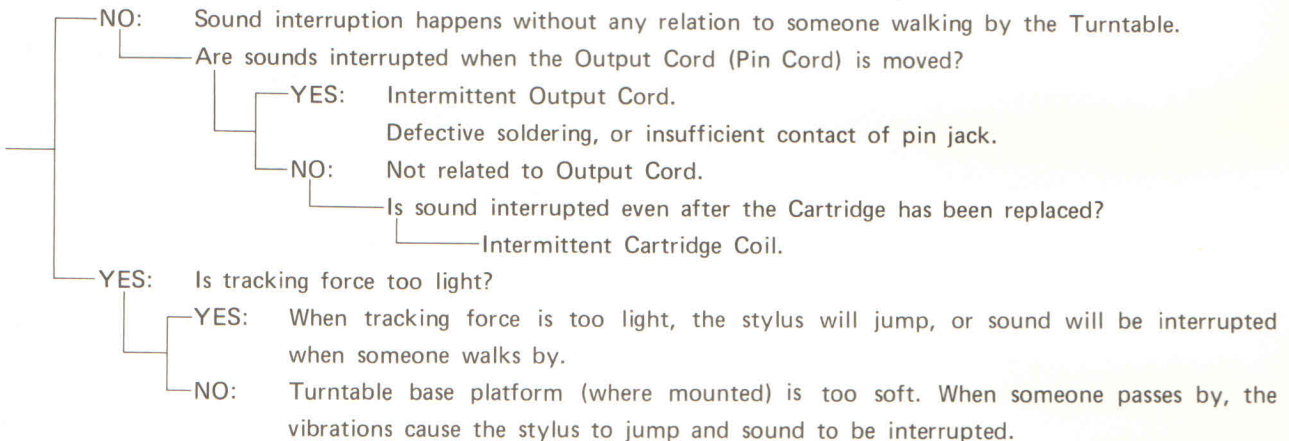

#### IV. Up and Down travel of the Tone Arm is Too Fast or Too Slow.

[Possible Cause]

- (a) Leaking oil from elevation mechanism.
- (b) Inadequate tracking force.
- (c) Too weak elevation spring.
- (d) Defective arm lifter mechanism

Operate Arm Lifter to check whether the up and down operations are too fast, or too slow.

- Going-down is too slow: Too light tracking force, or too weak elevation spring.
- Both are too slow: Leaking oil from elevation mechanism.
- Going-up is too slow: Too heavy tracking force, or too strong elevation spring.

#### V. Lead-In and Lead-Out Failure

- (1) Even after the Tone Arm has descended, the Stylus Tip will not move toward the inner grooves.
  - When the post of the Record Diameter Lever is disengaged from the Record Diameter Set Spring, the Adjust Lever Pin will stop moving, being prevented by the Record Diameter Lever; this in turn, prevents the Tone Arm from moving. (Fig. 16)

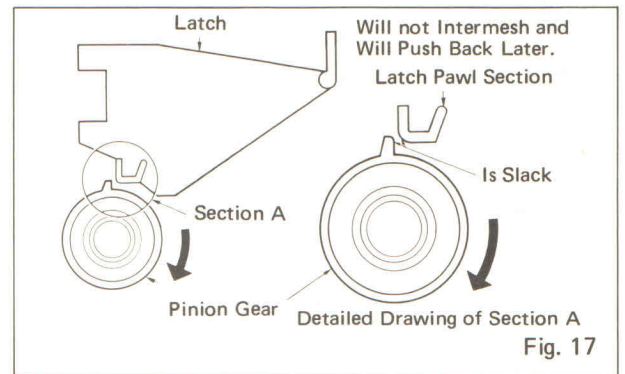
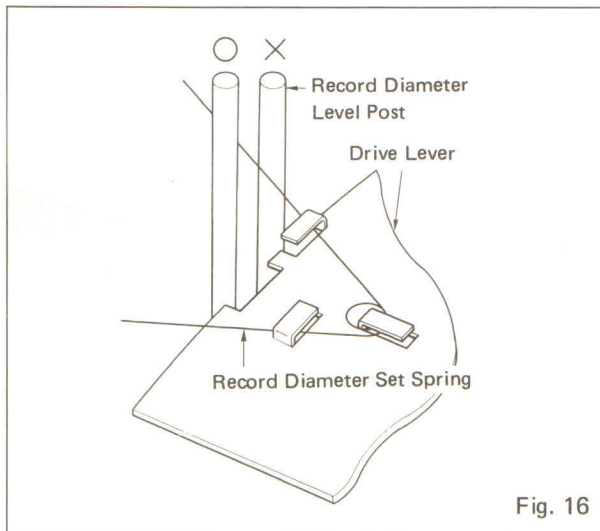

- (2) Even when the Start/Stop Lever is pulled, the Tone Arm will not "Lead-In".
  - If either the Latch or Pawl of the Pinion Gear has worn down (corners no longer sharp), the Latch and Pinion Gear's Pawl will not intermesh. Thus, "Lead-In" and "Return" will not be activated. (Fig. 17)
- (3) The descending position of the Stylus Tip at Lead-In is too far inward, or outward.
  - Adjust, referring to "LEAD-IN Adjustment" instructions.

- (4) At Lead-In, the Tone Arm does not move toward the record.  
Remove Rear Cover and check to see whether the Lead-In Pawl on the Drive Lever is positioned normally.
- NO: Correct the Pawl's position as shown in Fig. 18.
  - YES: Push Start/Stop Lever and see if it causes the Pinion Gear and Latch to intermesh.
    - NO: Defective Latch or Pinion Gear. Replace it.
    - YES: Is the pin on the Drive Lever located inside the groove of the Main Gear?
      - NO: The Drive Lever will not operate if its pin is not in the Main Gear's groove (Cam).

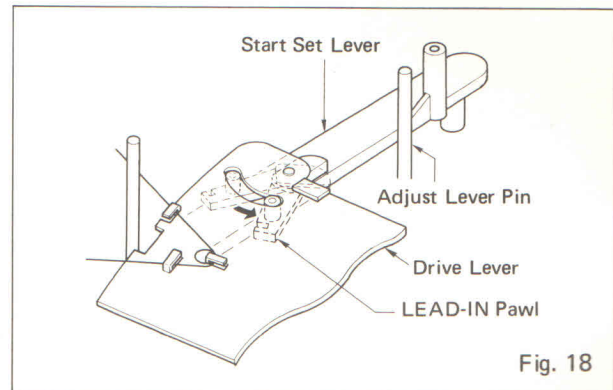

- (5) Tone Arm does not return when record has finished playing.  
\* Adjust, according to "LEAD-OUT Adjustment" instructions.  
Is it normal after adjusting the Lead-Out Adjust Screw?
- YES: Inadequate adjustment.
  - NO: Examine circuit. Check voltage of Photo Interrupter IC.

## MECHANISM OPERATING PRINCIPLE

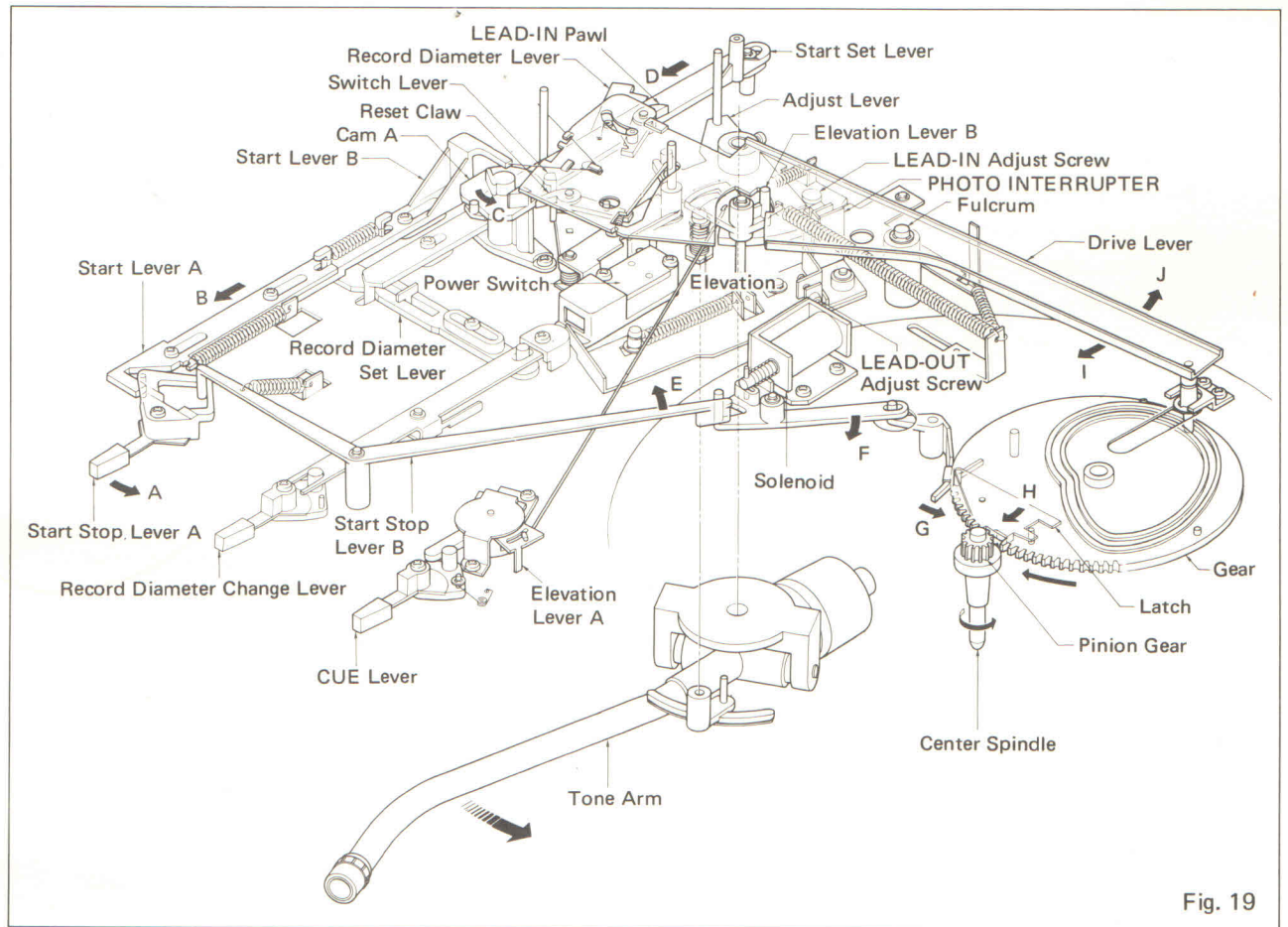

Fig. 19

### 1. Start-Up of DD Motor and Lead-In of Tone Arm (Refer to Fig. 19)

- (1) When Start/Stop Lever is pushed in the direction of arrow A, Start Levers A and B will move in the direction of arrow B.
- (2) The projecting portion of Cam A is pulled by the forward end of Start Lever B, turning Cam A in the direction of arrow C (moving from the position of Fig. 19 to Fig. 20). The projecting portion of Cam A will become horizontal as a result of this motion.
- (3) At the same time, the Start/Set Lever moves in the direction of arrow D, and maintains the condition shown in Fig. 21.
- (4) Meanwhile, the rotation of Cam A causes the Switch Lever to move along Cam A's surface, switching on the power switch and starting the motor.
- (5) On the other hand, the Start/Stop Lever B will be pushed in the direction of arrow E, so that

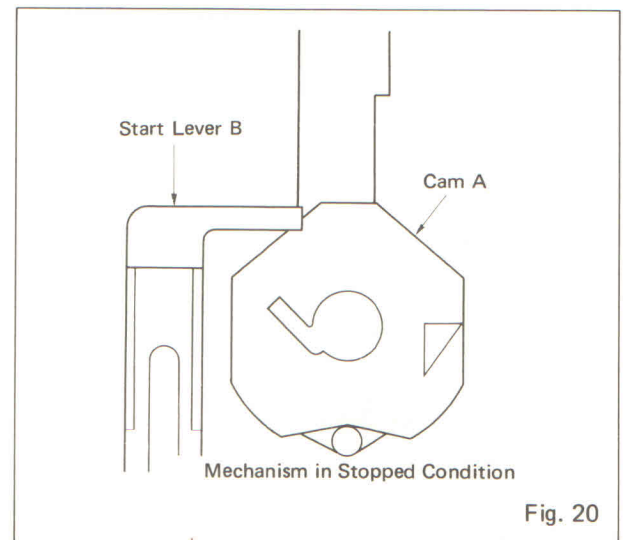

Fig. 20

each lever will move as indicated by arrows F and G and push the Latch attached to the Gear toward the center (arrow H).

- (6) As a result, the Latch and Pinion Gear will intermesh, turning the Main Gear.
- (7) The rear side of the Main Gear is grooved, forming a cam. The Pin on the forward end of the Drive Lever is in this groove. When the Main Gear turns, the Cam causes the Drive Lever to make see-saw movements centering around the fulcrum (arrows I and J).
- (8) The Drive Lever will move in the direction of arrow I first, causing the Lead-In Pawl on the Drive Lever to hit the post of the Start Lever and become horizontal.
- (9) Next, as the Drive Lever moves in the direction of arrow J, the Lead-In Pawl will engage Adjust Lever's Post and cause the Tone Arm to move in the direction of the record's inside diameter and the Reset Pawl will restore Cam A to its original condition (RESET).

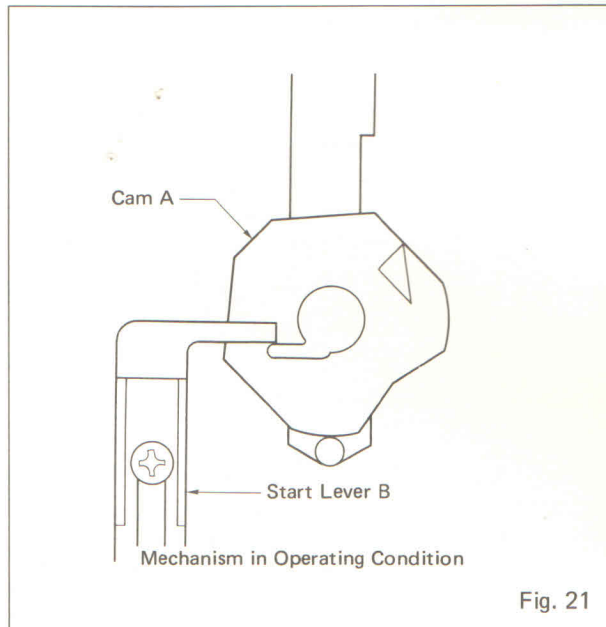

Fig. 21

## 2. Record Diameter Detection

Through record diameter detection, the amount of the Tone Arm's horizontal movement is controlled by the Record Diameter Lever (Fig. 22).

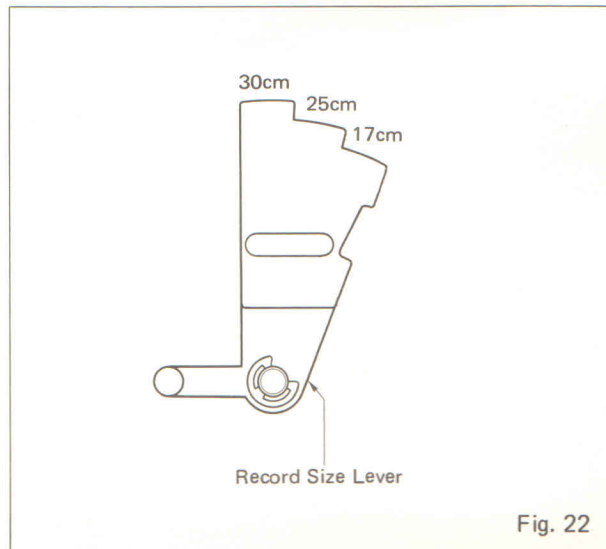

Fig. 22

## 3. Detection of Lead-Out Position

As this Turntable is the position-detecting type (unlike turntables of the speed detecting type) the Tone Arm will be absolutely free of any load during disc playing. Therefore, tone quality is not degraded.

- (1) As the Tone Arm moves toward the center and record playing is finished, the lever attached to the Adjust Lever will shield off the Photo Coupler beams (Fig. 23), turning off the Photo

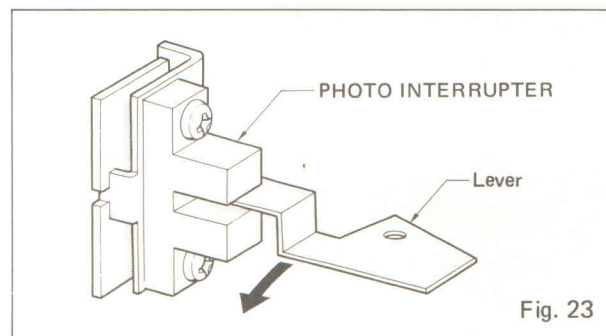

Fig. 23

Transistor that is attached to PS-4001 (Photo Interrupter). This causes IC-101 1/4 6 to become LOW level (referred to as "L") and to invert. As its output will become HIGH level (referred to as "H"), the output of IC-101 2/4 3 will become "L", whereas that of IC-101 3/4 11 will become "H".

This causes Q104 to turn on. Q103 will also turn on and cause a voltage to be applied to Solenoid S0-101, actuating it.

- (2) When the Solenoid is actuated, the levers linked with the Solenoid will be pulled in the direction of arrow F shown in Fig. 19. The rest of the operation is the same as that described in Step 1-(4).
- (3) When the Main Gear turns, the Drive Lever will again make see-saw movements, pushing back the post of the Adjust Lever and making the Tone Arm return to the Arm Rest.

#### 4. Up/Down Movements of Tone Arm

- (1) The Up and Down movements of the Arm Lifter is operated by the sloped section of the Lifter Lever, as the Lifter Lever is turned by the see-saw movements of the Drive Lever. (Fig. 24)
- (2) In manual operation, the Up and Down movements of the Arm Lifter are as follows:  
The operation of the Up/Down Lever activates the Elevation Lever and causes the Lifter Lever to turn.

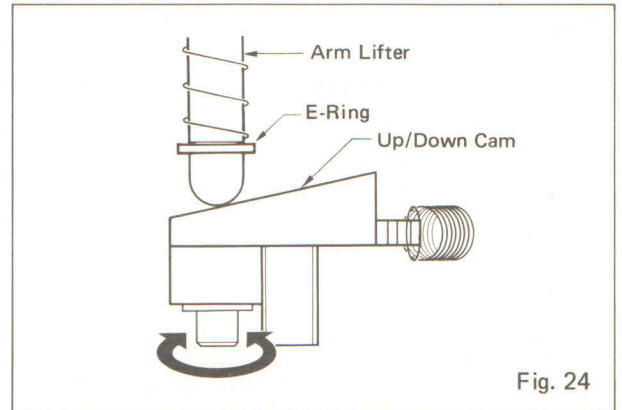

Fig. 24

## DESCRIPTION OF SERVO CIRCUIT

This circuit provides constant speed control over the Type-936 motor, by using signals obtained from the frequency generator incorporated in the motor. It utilizes dual feedback control, speed and phase. Inside the motor, the rotor is constructed with 90 magnet poles arranged around the circumference. When the rotor rotates, a sine wave is produced at the frequency generator terminals. The frequency produced is 50 Hz for 33-1/3 rpm and 67.5 Hz for 45 rpm. These signals (we'll call them FG signals) are fed to pins 2 and 3 of IC-1. Pins 1, 2 and 3 of IC-1 together with R4, C3 etc. compose an integrating amplifier, which amplifies the FG signals. These amplified signals are coupled via C-4 to pin 6 of IC-1. Pins 5, 6 and 7 of IC-1 together with R7, etc. compose a waveform shaping circuit, which converts the FG signals into rectangular waves. The rectangular-wave signals are fed to pin 4 of IC-2. IC-2 includes a frequency-to-voltage conversion circuit for speed control, a frequency divider for phase control, a phase comparator, etc.

First, let's take a look at the section associated with speed control. The rectangular-wave FG signals that have been fed to pin 4 are, in turn, fed to pin 7 after being converted into DC voltages that correspond to the frequencies by the frequency-to-voltage conversion circuit. This output will be decreasing when FG signal frequency gets higher, and increasing when the FG frequency signal gets lower. VR1, VR2 together with C5, etc. compose a time-constant circuit that is attached to the frequency-to-voltage conversion circuit. In the time constant circuit, switchover of time constants (frequencies) is made by the 33-1/3-45 rpm changeover switch, X13 and R10. Being connected to terminal 12 of IC-2, the 33-1/3-45 rpm changeover switch also carries out changeover of the frequency divisor in phase control.

Next, let us study the section associated with phase control. A 9.504 MHz oscillator is provided, which is composed of the crystal oscillator (X'tal) connected to pins 2 and 3, and C12 and C13. This oscillator signal is divided by the frequency divider (190,080 for 33-1/3 rpm and 140,800 for 45 rpm) into FG signal frequencies (50 Hz for 33-1/3 rpm, 67.5 Hz for 45 rpm). The rectangular-wave FG signals that are fed to pin 4 are compared with this reference frequency. The DC voltage that corresponds to the phase difference is output from pin 11. This output will decrease with an increase in phase and increase with a delay in phase.

In other words, both the speed control output and the phase control output have the same polarity (output drops with an increase in the motor's speed, and increases with decrease of motor speed). Both output signals are added by way of R13 and R18 and are fed to pin 3 of IC-3. Pins 1, 2 and 3 of IC-3 together with R19, R20 and R21 form a linear amplifier, which amplifies the control signals fed out from IC-2, and then adds them into the first stage (X11) of the motor drive circuit. The motor drive circuit (which uses X11 for its first stage) is connected to the motor's drive coil via connector terminals 4, 7, 8 and 11. The motor stator contains 48 coils wound on 24 slots and two Hall Effect elements. The inside wall of the rotor magnet has 12 poles and when it rotates, the changing magnetic polarity affects the Hall Elements to supply information for the electronics circuit to change phase and magnitude of current through each coil as necessary for sustaining the rotation. (Thus, the Hall Effect devices become the commutator for the Motor.) The rotating action force has 4 phases of 12 poles. This 4-phase drive coil generates a turning moment, current-driven by X1, X2, X3 and X4. Connector terminals 5, 6, 9 and 10 feed X5, X6, X7 and X8 the output signals from the Hall elements incorporated in the Motor. These signals, the phases of which are 90° apart, are used to cause X5, X6, X7 and X8 to perform switching operations according to the rotary direction of the motor. This, in turn, will cause the drive transistors, X1, X2, X3 and X4 to carry out successive switching operations, and these provide signals for the drive coil. Transistors X9, X10, etc. serve the function of varying the current that is supplied to transistors X5, X6 and X7 according to the control signals that are fed to the base of X11. Stable Motor speed is assured by this drive circuit, whose function consists of detecting the motor coil's drive current (by means of R44, the emitter resistor common to X1, X2, X3 and X4) and of effecting negative feedback of the detected current to the emitter of X11.

The following gives a brief description of the operations of the servo system:

Let's assume, for example, that a load torque has been applied that will cause a drop in the Motor's speed. This will cause the FG signal frequency to drop, and the level of the control output signal from IC-2 to rise. These output signals of increased levels are first



amplified by IC-3 and then applied to the base of the first stage (X11) of the drive circuit. This will cause the current that flows through the drive coil to increase and the speed of the motor to increase as well. As a result, the motor's speed will be maintained constant.

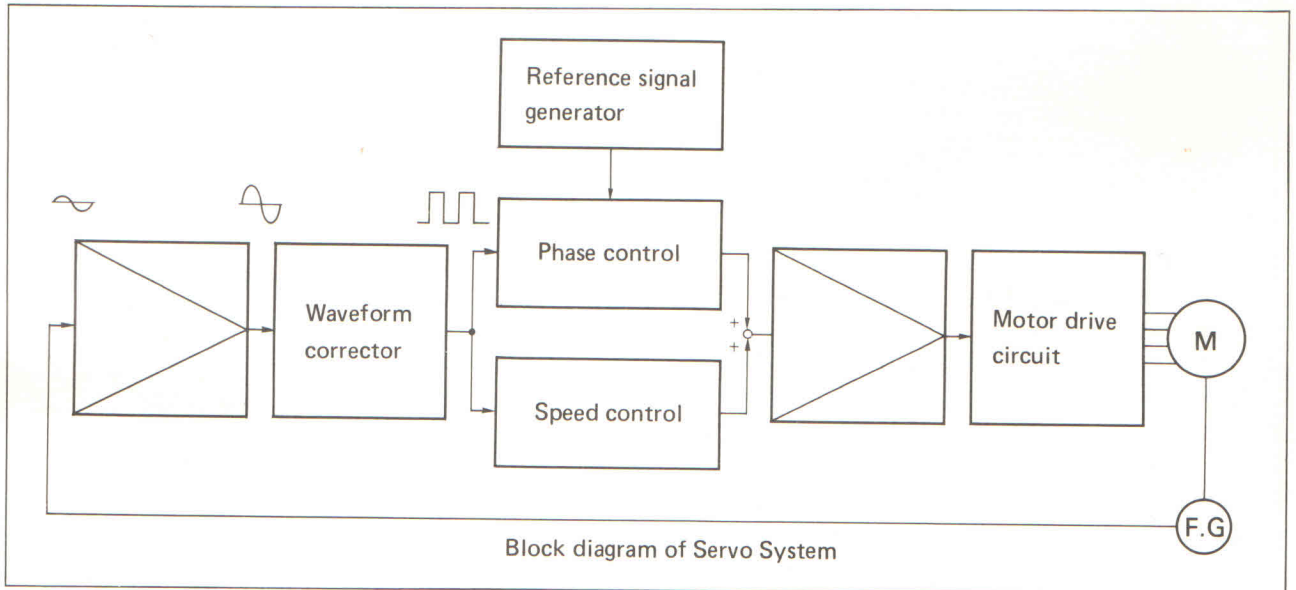

PRINTED CIRCUIT BOARD

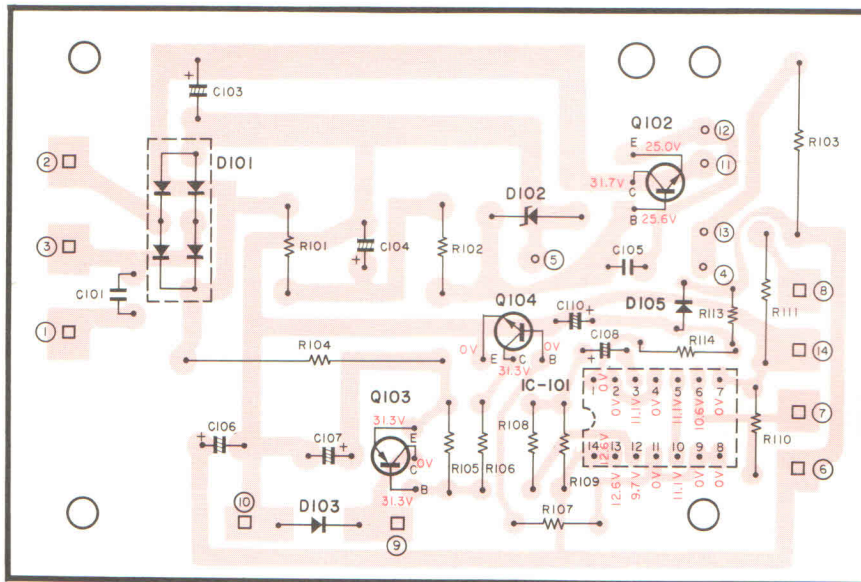
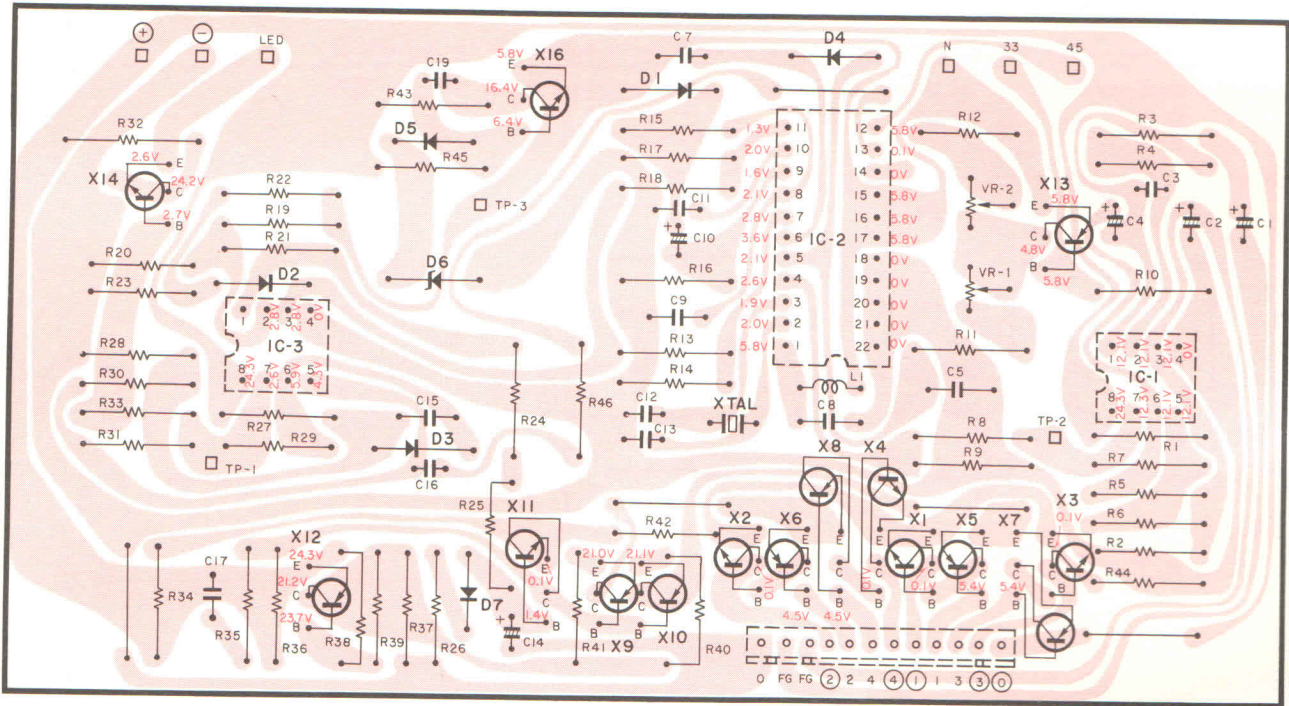

SCHEMATIC DIAGRAM

19  
→

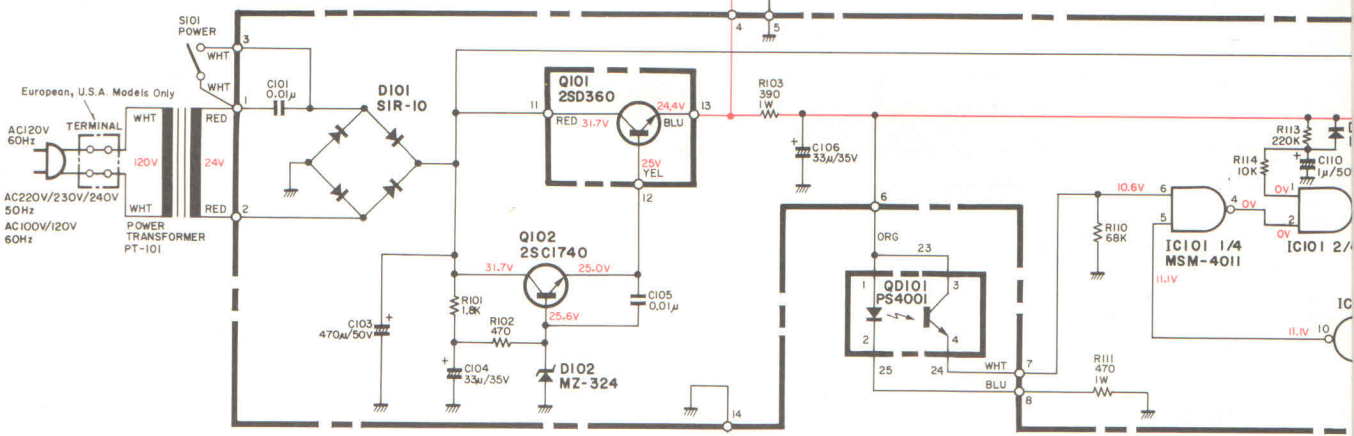
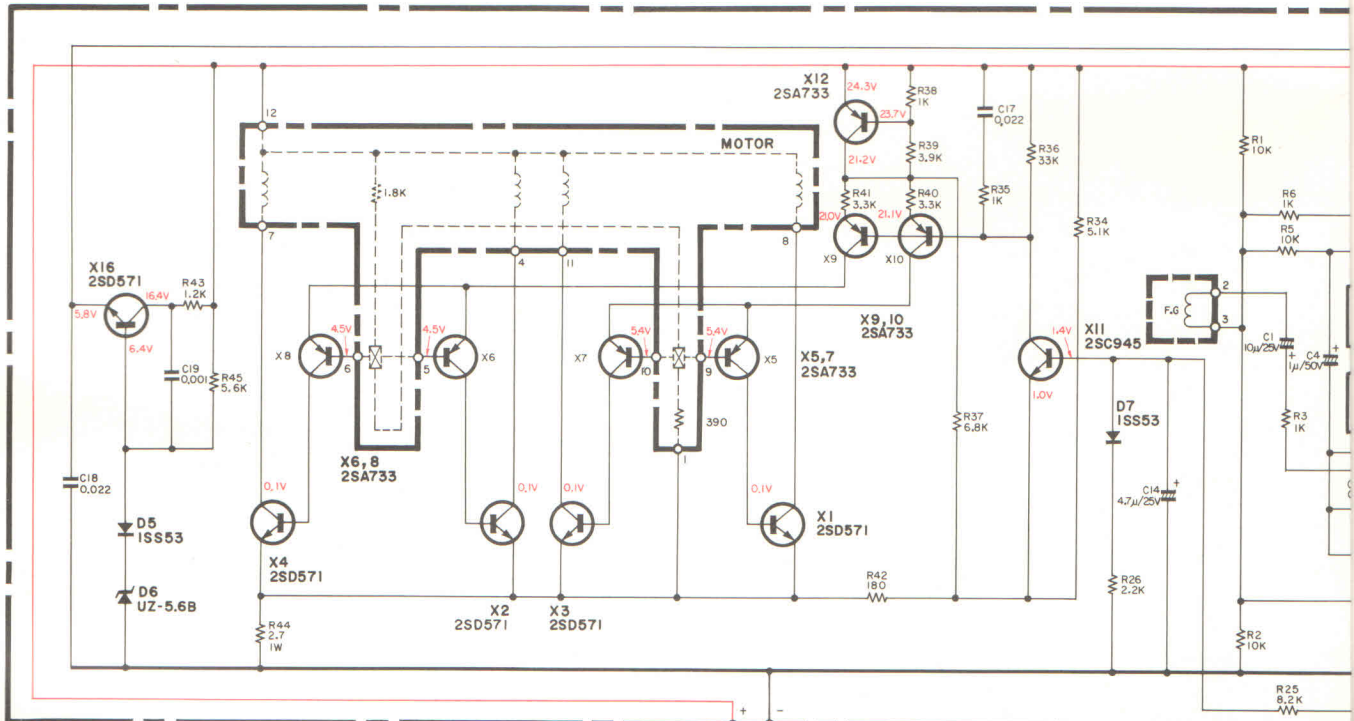

Note:  
Wire colors may differ from unit to unit.  
BLK.....Black    BRN.....Brown    RED.....Red  
ORG.....Orange    YEL.....Yellow    GRN.....Green  
BLU.....Blue    PPL.....Purple    GRY.....Grey  
WHT.....White    PNK.....Pink

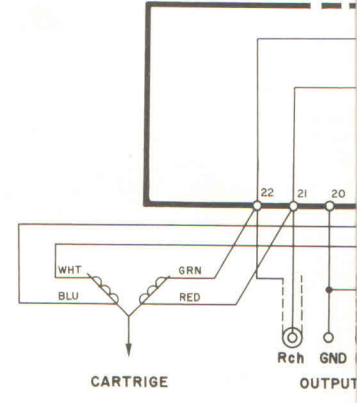

19  
←

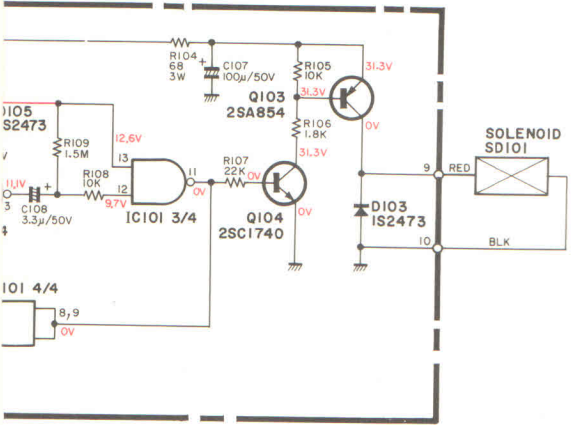
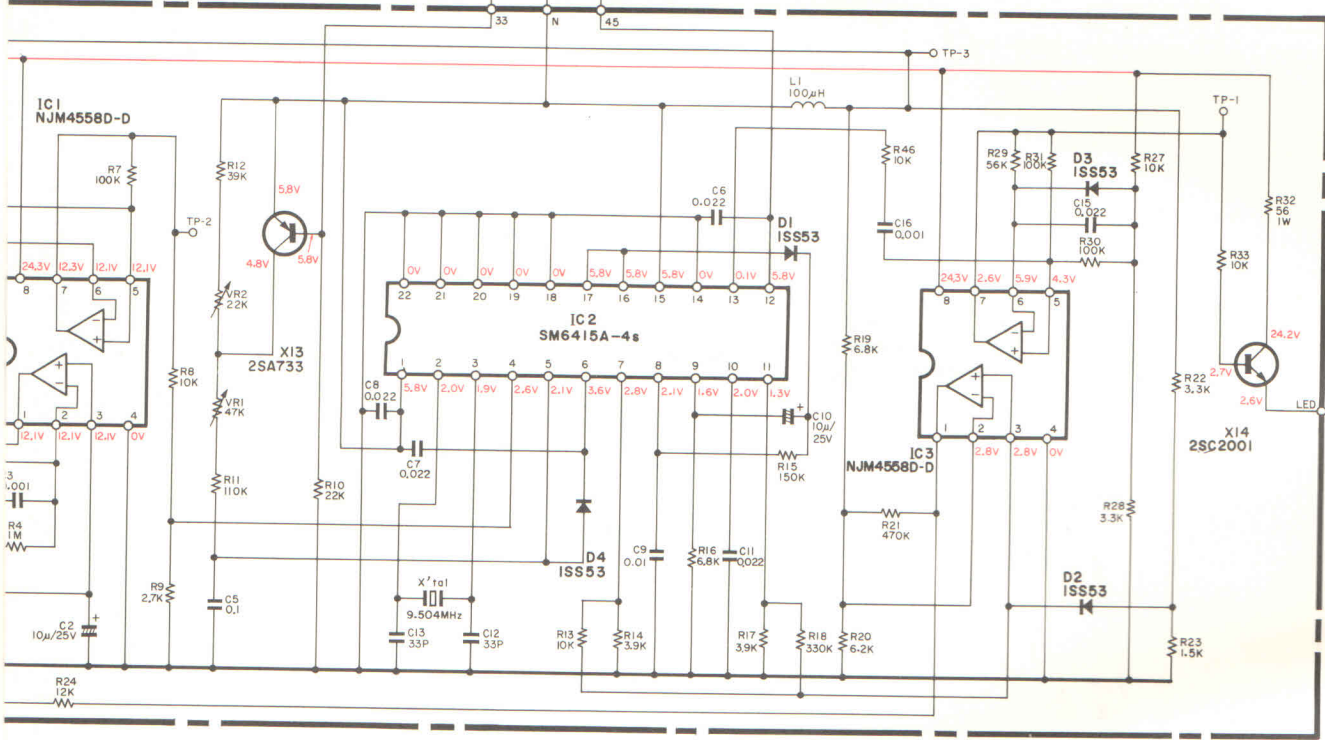
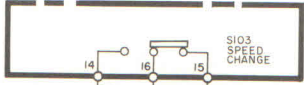

EXTERNAL VIEW of the TRANSISTOR, IC, DIODE and PHOTO INTERRUPTER

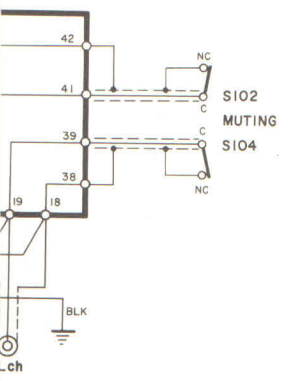
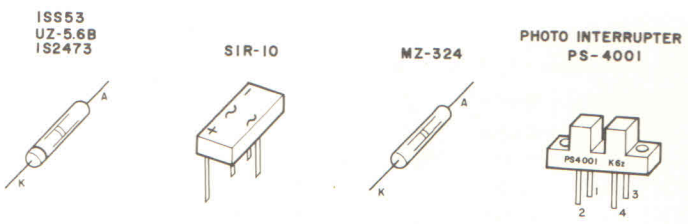
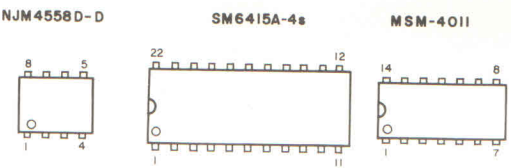
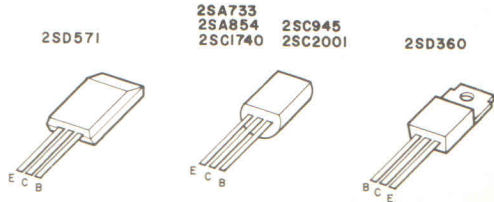

19  
←

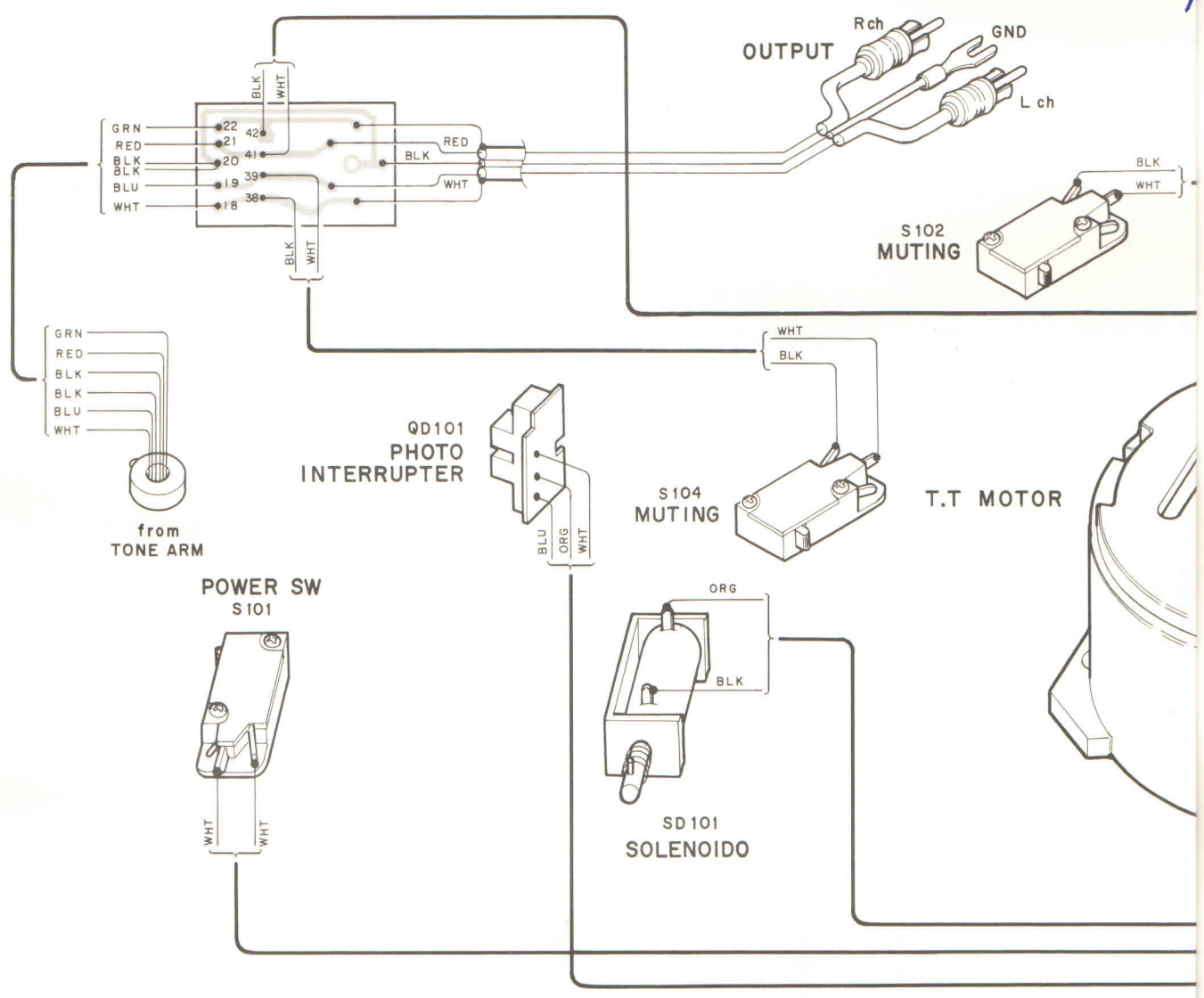

SERVO C. BOARD

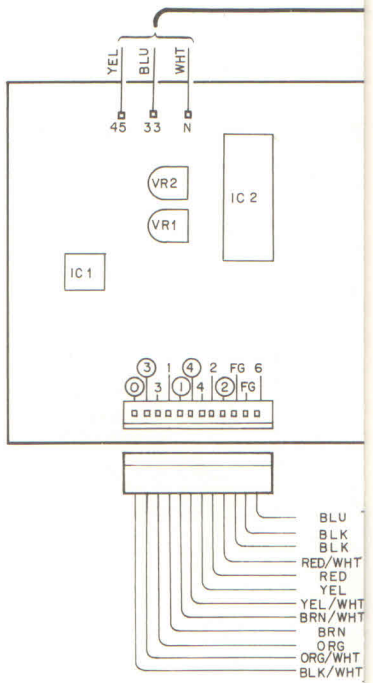

NOTE: Wire colors may differ from unit to unit.

- |                |                |
|----------------|----------------|
| BRN.....Brown  | RED.....Red    |
| ORG.....Orange | YEL.....Yellow |
| GRN.....Green  | BLU.....Blue   |
| PPL.....Purple | GRY.....Grey   |
| WHT.....White  | BLK.....Black  |

- BLU
- BLK
- RED/WHT
- RED
- YEL
- BRN/WHT
- BRN
- ORG/WHT
- BLK/WHT

70  
↑

AC 220V/230V/240V 50Hz  
(European Models Only)  
120V 60Hz  
(U.S.A Models Only)

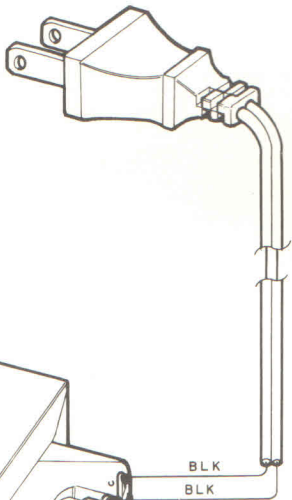

POWER  
TRANSFORMER  
PT101

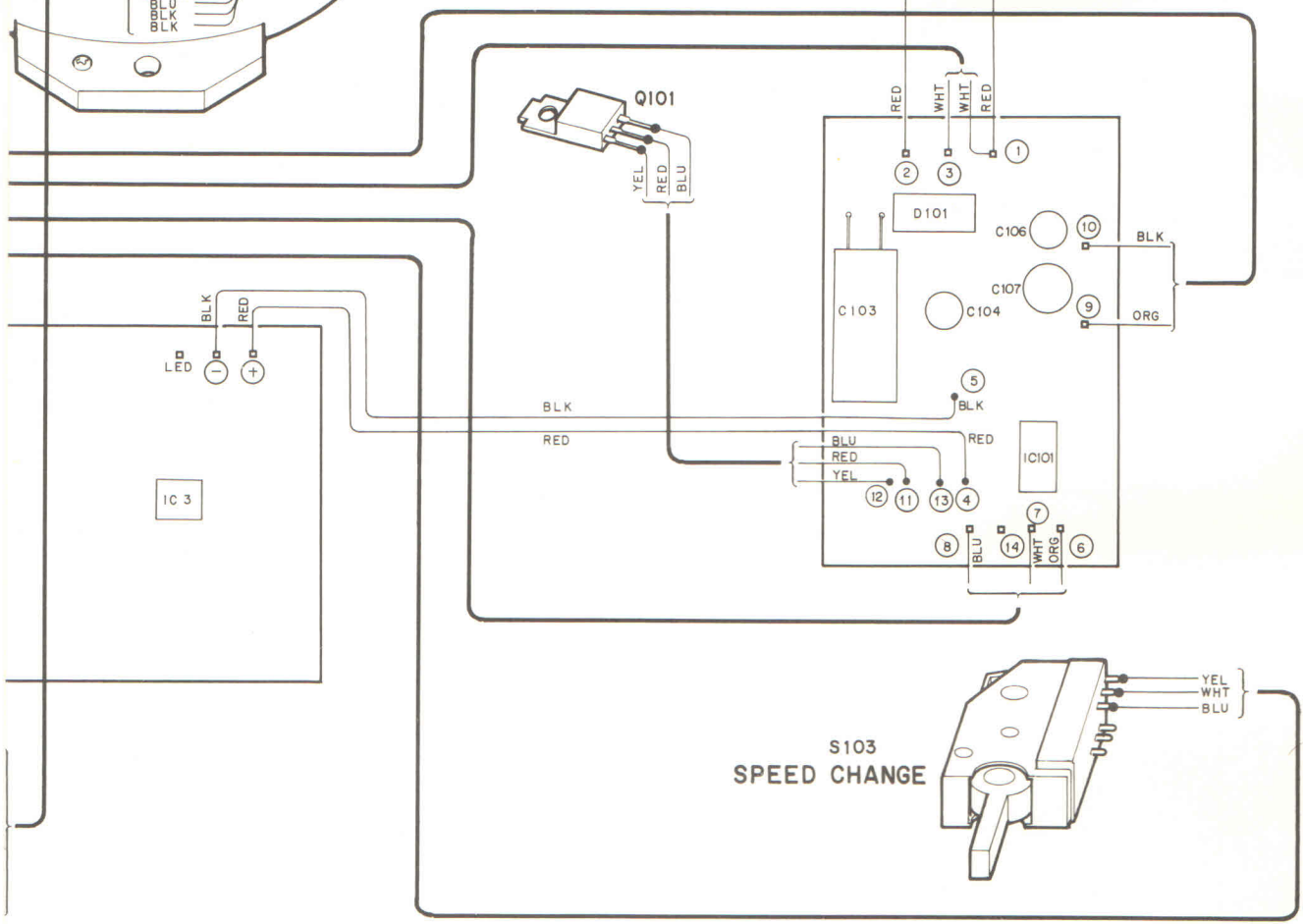
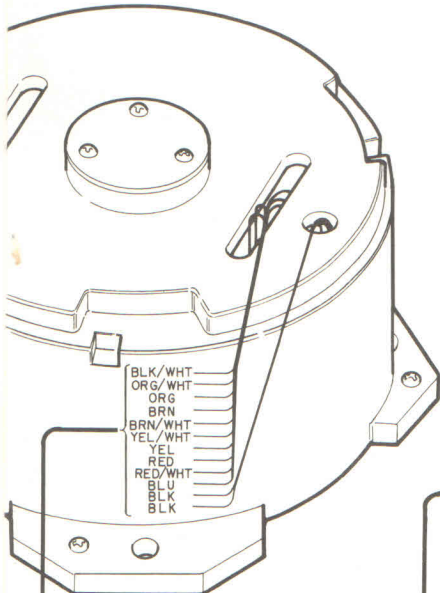
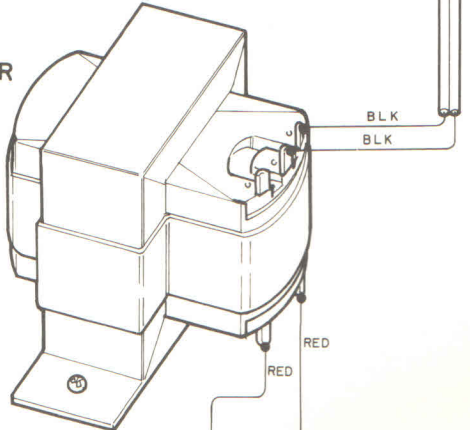

# EXPLODED VIEW

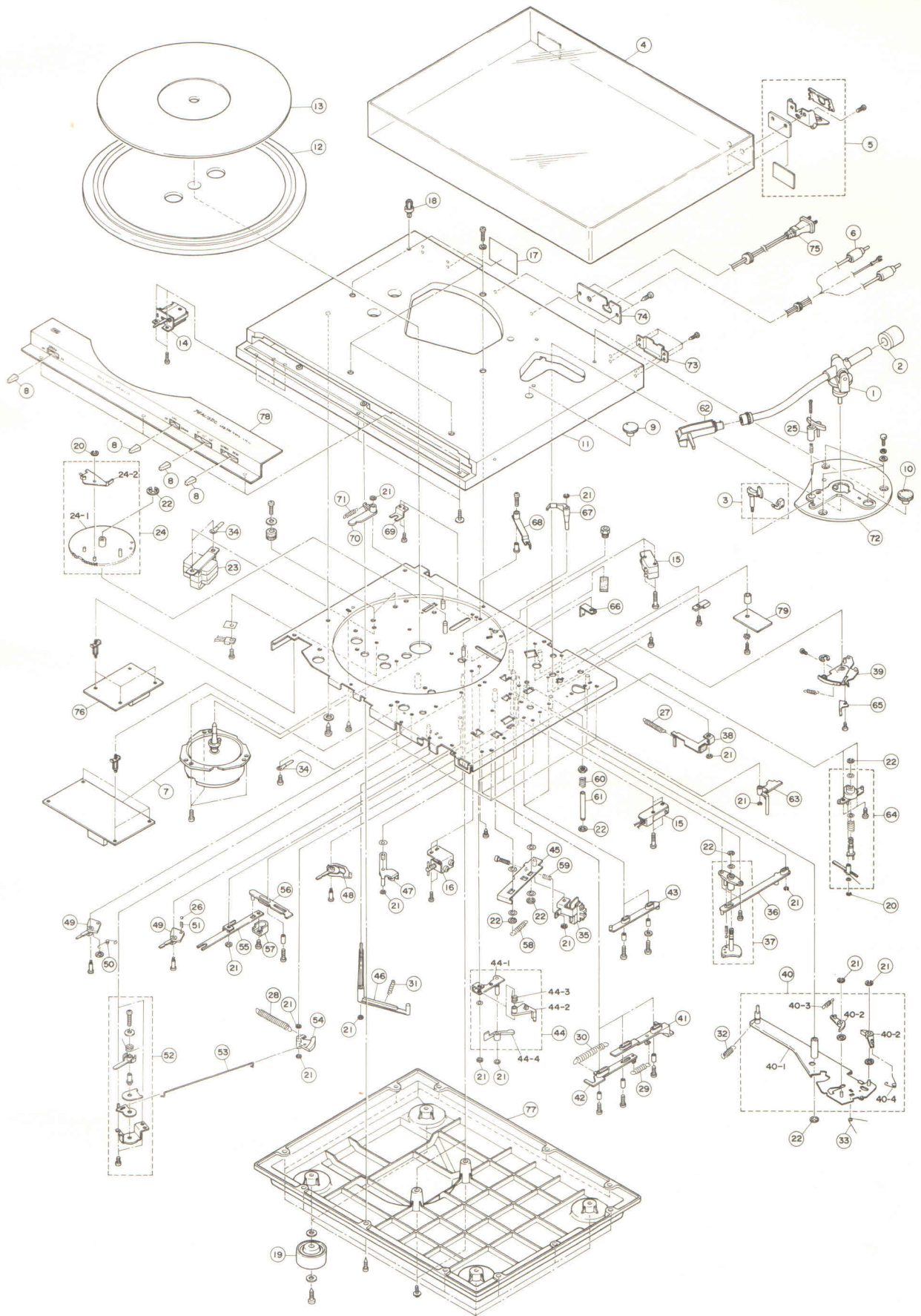

## PARTS LIST

Ref. No.	Description	RS. No.	Mfr. No.	
C1	Capacitor	10 $\mu$ F 25V		
C2	Capacitor	10 $\mu$ F 25V		
C3	Capacitor	0.001 $\mu$ F		
C4	Capacitor	1 $\mu$ F 50V		
C5	Capacitor	0.1 $\mu$ F		
C6	Capacitor	0.022 $\mu$ F		
C7	Capacitor	0.022 $\mu$ F		
C8	Capacitor	0.022 $\mu$ F		
C9	Capacitor	0.01 $\mu$ F		
C10	Capacitor	10 $\mu$ F 25V		
C11	Capacitor	0.022 $\mu$ F		
C12	Capacitor	33pF		
C13	Capacitor	33pF		
C14	Capacitor	4.7 $\mu$ F 25V		
C15	Capacitor	0.022 $\mu$ F		
C16	Capacitor	0.001 $\mu$ F		
C17	Capacitor	0.022 $\mu$ F		
C18	Capacitor	0.022 $\mu$ F		
C19	Capacitor	0.001 $\mu$ F		
C101	Capacitor -ceramic	0.01 $\mu$ F 50V	U140S005H27	
C103	Capacitor -electrolytic	470 $\mu$ F 50V	U182S021H73	
C104	Capacitor -electrolytic	33 $\mu$ F 50V	U182S021H68	
C105	Capacitor -ceramic	0.01 $\mu$ F 50V	U140S005H27	
C106	Capacitor -electrolytic	33 $\mu$ F 35V	U182S021H68	
C107	Capacitor -electrolytic	100 $\mu$ F 50V	U182S021H70	
C108	Capacitor -electrolytic	3.3 $\mu$ F 50V	U182S031H42	
C110	Capacitor-electrolytic	1 $\mu$ 50V	U182S033H40	
D1	Diode	1SS53	DX-0322	M07314320
D2	Diode	1SS53	DX-0322	M07314320
D3	Diode	1SS53	DX-0322	M07314320
D4	Diode	1SS53	DX-0322	M07314320
D5	Diode	1SS53	DX-0322	M07314320
D6	Diode	UZ-5.6B	DX-1053	M07314321
D7	Diode	1SS53	DX-0322	M07314320
D101	Diode	SIR10	DX-1168	M07151320
D102	Diode	MZ324	DX-1169	M07288320
D103	Diode	1S2473	DX-0299	M07060320



Ref. No.	Description	RS. No.	Mfr. No.	
D105	Diode	1S2473	DX-0249	M07060320
IC1	IC	NJM4558DD	MX-3449	M07314343
IC2	IC	SM6415-4S	MX-3724	M07314344
IC3	IC	NJM4558DD	MX-3449	M07314343
IC101	IC	MSM4011	MX-3725	M07297343
L1	Coil	100 $\mu$ H		
Q101	Transistor	2SD360		M05079311
Q102	Transistor	2SC1740		M05104313
Q103	Transistor	2SA854		M07137308
Q104	Transistor	2SC1740		M05104313
R1	Resistor-carbon	10Kohm		
R2	Resistor-carbon	10Kohm		
R3	Resistor-carbon	1Kohm		
R4	Resistor-carbon	1Mohm		
R5	Resistor-carbon	10Kohm		
R6	Resistor-carbon	1Kohm		
R7	Resistor-carbon	100Kohm		
R8	Resistor-carbon	10Kohm		
R9	Resistor-carbon	2.7Kohm		
R10	Resistor-carbon	22Kohm		
R11	Resistor-carbon	110Kohm		
R12	Resistor-carbon	39Kohm		
R13	Resistor-carbon	10Kohm		
R14	Resistor-carbon	3.9Kohm		
R15	Resistor-carbon	150Kohm		
R16	Resistor-carbon	6.8Kohm		
R17	Resistor-carbon	3.9Kohm		
R18	Resistor-carbon	330Kohm		
R19	Resistor-carbon	6.8Kohm		
R20	Resistor-carbon	6.2Kohm		
R21	Resistor-carbon	470Kohm		
R22	Resistor-carbon	3.3Kohm		
R23	Resistor-carbon	1.5Kohm		
R24	Resistor-carbon	12Kohm		
R25	Resistor-carbon	8.2Kohm		
R26	Resistor-carbon	2.2Kohm		
R27	Resistor-carbon	10Kohm		

Ref. No.	Description	RS. No.	Mfr. No.
R28	Resistor-carbon	3.3Kohm	
R29	Resistor-carbon	56Kohm	
R30	Resistor-carbon	100Kohm	
R31	Resistor-carbon	100Kohm	
R32	Resistor-metal	56ohm 1W	
R33	Resistor-carbon	10Kohm	
R34	Resistor-carbon	5.1Kohm	
R35	Resistor-carbon	1Kohm	
R36	Resistor-carbon	33Kohm	
R37	Resistor-carbon	6.8Kohm	
R38	Resistor-carbon	1Kohm	
R39	Resistor-carbon	3.9Kohm	
R40	Resistor-carbon	3.3Kohm	
R41	Resistor-carbon	3.3Kohm	
R42	Resistor-carbon	180ohm	
R43	Resistor-carbon	1.2Kohm	
R44	Resistor-metal	2.7ohm 1W	
R45	Resistor-carbon	5.6Kohm	
R46	Resistor-carbon	10Kohm	
R101	Resistor-carbon	1.8Kohm 1/4W J	U103S014H22
R102	Resistor-carbon	470ohm 1/4W J	U103S014H15
R103	Resistor-metal	390ohm 1W J	U105S005H20
R104	Resistor-metal	68ohm 3W J	U105S002H03
R105	Resistor-carbon	10Kohm 1/4W J	U103S014H31
R106	Resistor-carbon	1.8Kohm & 1/4W	U103S014H22
R107	Resistor-carbon	22Kohm 1/4W	U103S014H35
R108	Resistor-carbon	10Kohm 1/4W J	U103S014H31
R109	Resistor-carbon	1.5Mohm 1/4W	U103S014H56
R110	Resistor-carbon	68Kohm 1/4W	U103S014H41
R111	Resistor-metal	470ohm 1W J	U105S005H21
R113	Resistor-carbon	220Kohm 1/4W	U103S014H35
R114	Resistor-carbon	10Kohm 1/4W	U103S014H31
VR1	VR-semifixed	47Kohm	
VR2	VR-semifixed	22Kohm	
X1	Transistor	2SD571	M07228303
X2	Transistor	2SD571	M07228303
X3	Transistor	2SD571	M07228303

Ref. No.	Description	RS. No.	Mfr. No.
X4	Transistor	2SD571	M07228303
X5	Transistor	2SA733	M05071301
X6	Transistor	2SA733	M05071311
X7	Transistor	2SA733	M05071311
X8	Transistor	2SA733	M05071311
X9	Transistor	2SA733	M05071311
X10	Transistor	2SA733	M05071311
X11	Transistor	2SC945	M07229304
X12	Transistor	2SA733	M05071311
X13	Transistor	2SA733	M05071311
X14	Transistor	2SC2001	M07314303
X16	Transistor	2SD571	M07228303
X'tal	Crystal	9.5040	MX-2633 M07314310

Ref. No.	Description	RS. No.	Mfr. No.
1	Tonearm	RC-6382	M07314610
2	Counter Weight	RC-8052	M07243649
3	Arm rest assembly	RD-5393	M07150618
4	Dust Cover	Y-1006	M07314690
5	Hinge	RD-5538	M07243125
6	Patch cord	W-2243	M07314445
7	Motor (Servo PCB)	K-4452	M07314637
8	Knob (Play)	K-3176	M07314650
9	Knob (Repeat)	K-3177	M07244650
10	Knob (Anti-skating)	K-3178	M07295651
11	Cabinet assembly	Y-1507	M07314100
12	Plate	RC-4140	M07314601
13	Turn table mat	RC-4141	M07314757
14	Level switch	S-5057	M07244660
15	Micro switch	S-6058	M07243430
16	Solenoid	S-9098	M07314390
17	Name plate	RD-5539	M07314605
18	Pin for 45 adapter	RC-7104	M04142716
19	Leg	F-1135	M07296695
20	E-Ring 2	HE-0004	M07314741
21	E-Ring 3	HE-0008	M07296741

Ref. No.	Description	RS. No.	Mfr. No.
22	E-Ring 4	HE-0010	M07296743
23	Power transformer (USA models only)	TA-0691	M07314549
23	Power transformer (European models only)		M07319549
24	Gear assembly		U530C008G02
24-1	Gear	RD-5537	M07314645
24-2	Latch	RD-5540	M07314646
25	Arm lifter	RC-6381	M07243619
26	Steel board	RD-5541	M07314627
27	Spring	RD-5542	M07314670
28	Spring	RD-5543	M07314671
29	Spring	RD-5544	M07314672
30	Spring	RD-5545	M07314673
31	Spring	RD-5546	M07314674
32	Spring	RD-5547	M07314675
33	Spring	RD-5548	M07314676
34	Clamper		540S005H01
35	PHOTO INTERRUPTER	RD-5550	M07314309
	45 rpm adapter	RC-7099	M07191603
36	45 rpm adapter lever		U525D621H03
37	Cam A assembly		U536D053G01
38	Lever		U525D677G01
39	Adjust lever		U525D639G03
40	Drive lever		U525C020G01
40-1	Lever		U525C019G01
40-2	Lead in claw		U525D620H02
40-2	Reset claw		U525D620H02
40-3	Spring		U570D738H02
40-4	Spring		U570D733H01
41	Start lever		U525D622H01
42	Start lever B		U525D623H01
43	Record size set lever B		U525D618H01
44	Switch lever		U525D658G01
44-1	Lever assembly		U525D636G01
44-2	Lever		U525D615H02
44-3	Spring		U570D750H01
44-4	Lever		U525D616H03
45	Lever		U525D678G01

Ref. No.	Description	RS. No.	Mfr. No.
46	Start/Stop lever B		U525D614H02
47	Lever		U525D676G01
48	Start/Stop lever A		U525D682G02
49	Record size set lever		U525D681G02
49	CUE lever		U525D681G02
50	Spring		U570D734H01
51	Spring		U570D737H01
52	Elevation lever		U525D640G01
53	Link		U526D177G02
54	Elevation lever		U525D612H02
55	Record size set lever		U525D680G01
56	Record size set lever		U525D619H01
57	Holder		U541D069H01
58	Spring		U570D788H01
59	Spring		U670D787H01
60	Spring		U570D763H02
61	Elevation shaft		U531D265H01
62	Cartridge assembly	R9000ELWS	
63	Record size set lever		U525D617H03
64	Anti-skating lever		U945C003G01
65	Lever		525D670H02
66	Holder		546D121H02
67	Lever		525D696G01
68	Muting lever		525D695G02
69	Holder Z		549D106H01
70	Lever		525D611H02
71	Spring		570D746H04
72	Ornament		703B026H02
73	Holder U		547Y005H01
74	Holder F		544D081H01
75	Power cord (USA models only)		242C777H02
75	Power cord (European models only)		242C800H02
76	PS-PCB		241C520G02
77	Board bottom		700C019G03
78	Panel assembly		712C136G01
79	Muting-PCB		241C508H32

RADIO SHACK  A DIVISION OF TANDY CORPORATION

U.S.A.: FORT WORTH, TEXAS 76102  
CANADA: BARRIE, ONTARIO L4M 4W5

---

**TANDY CORPORATION**

AUSTRALIA	BELGIUM	U. K.
280-316 VICTORIA ROAD RYDALMERE, N.S.W. 2116	PARC INDUSTRIEL DE NANINNE 5140 NANINNE	BILSTON ROAD WEDNESBURY, WEST MIDLANDS WS10 7JN