

Realistic MPX-215 (90LX063)

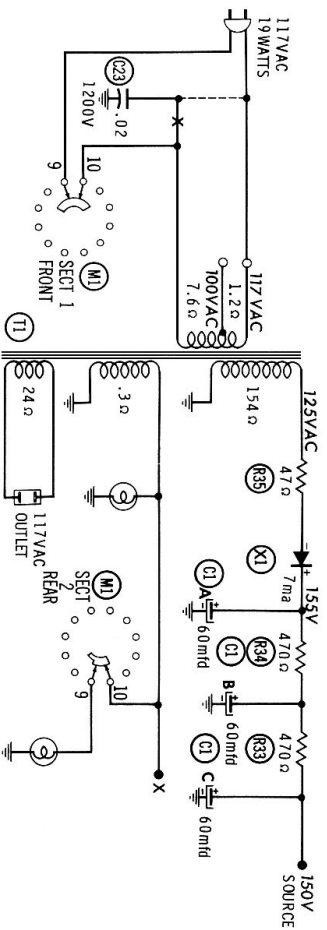

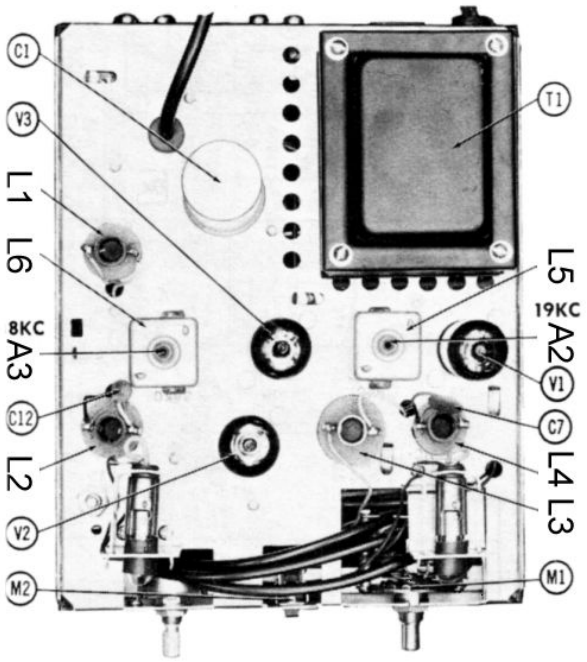

Realistic MPX-215 (90LX063) Alignment Data

MULTIPLYX ALIGNMENT USING FM STEREO GENERATOR AND AUDIO OSCILLATOR

SIGNAL GENERATOR	CONNECT SCOPE	ADJUST	REMARKS
1. 19KC to MPX Input.	Vert. input to pin 2 of V1, low side to ground.	A1	Adjust for maximum.
2. "	Vert. input to pin 2 of V2, low side to ground.	A2	Adjust for maximum. Set scope to lock in 2 cycle waveform.
3. "	Vert. input to point A, low side to ground.	A3	Adjust for maximum 4 cycle waveform.
4. 67KC to MPX Input	"	A4, A5	Adjust for MINIMUM.
5. 20 KC to point B low side to ground.	Vert. input to point C, low side to ground.	A6	Adjust for MINIMUM.