

*REALISTIC*®

# Service Manual

31-1985

SA-2000  
**STEREO AMPLIFIER**  
Catalog Number 31-1985

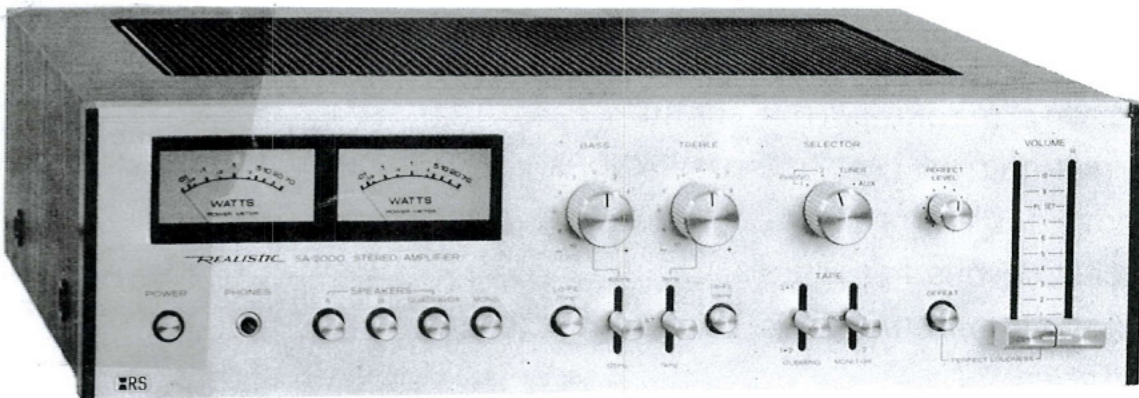

CUSTOM MANUFACTURED FOR RADIO SHACK  A DIVISION OF TANDY CORPORATION

# CONTENTS

	PAGE
1. SPECIFICATIONS .....	3
2. DISASSEMBLY INSTRUCTIONS .....	4
3. BLOCK DIAGRAM .....	5
4. ADJUSTMENT PROCEDURES .....	6
5. ADJUSTMENT POINTS .....	6
6. TROUBLESHOOTING .....	7-10
7. LEVEL DIAGRAM .....	11
8. 5031 PRE-AMP & TONE CONTROL BOARD .....	12
9. 6045 MAIN AMP BOARD .....	13-14
10. 7129 PUSH SWITCH BOARD .....	15
11. 7130 TAPE & TONE SWITCH BOARD .....	16
12. SEMICONDUCTOR LEAD IDENTIFICATIONS .....	17
13. ELECTRICAL PARTS LIST .....	18-22
14. MISCELLANEOUS PARTS LIST .....	22-23
15. SCHEMATIC DIAGRAM .....	SEPARATE SHEET
16. EXPLODED VIEW .....	SEPARATE SHEET

# SPECIFICATIONS

	NOMINAL	LIMIT
1. RMS OUTPUT POWER At 0.3% THD for 20 ~ 20,000 Hz into 8 ohms (per channel, both channels driven)	60 W	55 W
2. IM DISTORTION (at 40 W, 60/7,000 4/1)	0.1 %	0.3 %
3. HARMONIC DISTORTION (at 40 W)		
20 Hz	0.03 %	0.15 %
1,000 Hz	0.03 %	0.15 %
20,000 Hz	0.05 %	0.15 %
4. FREQUENCY RESPONSE (Aux at 1 W, 8 ohms load) ±1.5 dB	20~70,000Hz (+1.5/-4 dB)	20 ~ 20,000 Hz
5. INPUT SENSITIVITY (for 60 W)		
PHONO 1&2	2.6 mV	2.6 ± 0.5 mV
TUNER	165 mV	165 ± 30 mV
AUX	165 mV	165 ± 30 mV
TAPE IN 1&2	165 mV	165 ± 30 mV
6. INPUT IMPEDANCE		
PHONO 1&2	50 K ohm	
TUNER	70 K ohm	
AUX	70 K ohm	
TAPE IN 1&2	70 K ohm	
7. PHONO EQUALIZATION		
30 ~ 15,000 Hz	RIAA ± 1 dB	RIAA ± 1.5 dB
8. PHONO AMP OVER LOAD CAPABILITY (at 1% distortion)	150 mV	120 mV
9. TONE CONTROL		
BASS turn-over 125 Hz at 100 Hz:	±4 dB	±4±1.5 dB
turn-over 400 Hz at 100 Hz:	±12 dB	±12±2 dB
TREBLE turn-over 3 kHz at 10 kHz:	±9 dB	±9±2 dB
turn-over 7 kHz at 10 kHz:	±5 dB	±5±1.5 dB
10. HIGH FILTER	10 kHz -6 dB	-6±2 dB
11. LOW FILTER	70 Hz -6 dB	-6±2 dB
12. LOUDNESS COMPENSATION		
50 Hz	+11 dB	+11±2 dB
100 Hz	+9 dB	+9±2 dB
13. CHANNEL SEPARATION (AUX input, 100 ~ 10,000 Hz, 18 volts output at 8 ohm load)	50 dB	40 dB
14. SIGNAL-TO-NOISE RATIO (Input shorted)		
PHONO 1&2	65 dB	60 dB
TUNER, TAPE 1&2, AUX	85 dB	75 dB
15. TAPE OUTPUT LEVEL (at PHONO input 3 mV)	200 mV	200 ± 30 mV
16. RESIDUAL NOISE (at minimum VOLUME)	0.5 mV	1.5 mV
17. LOAD IMPEDANCE		4 ~ 16 ohms
18. POWER SOURCE		
AC 120 Volts, 60 Hz*		
17 Watts, No Signal		
280 Watts, Full Signal (8 ohms, both channels)		
60 Watts)		
*220/240V AC, 50 Hz for European and Australian Models.		

NOTE: Nominal Specs represent the design specs; all units should be able to approximate these—some will exceed and some may drop slightly below these specs. Limit Specs represent the absolute worst condition which still might be considered acceptable; in no case should a unit perform to less than within any Limit Spec.

# DISASSEMBLY INSTRUCTIONS

1. Removing chassis from Wooden Cabinet
  - a) Remove the four screws (#65) from both sides of the Wooden Cabinet.
  - b) Remove the screw (#21) from the middle of back panel and then lift off the Wooden Cabinet.
2. Removing the Front Panel
  - a) Remove the knobs from VOLUME, PERFECT LEVEL, SELECTOR, TAPE MONITOR, TAPE DUBBING, TREBLE, BASS and both turn-over switch knobs.
  - b) Remove four screws (#30) from top and bottom of Front Panel then remove the Front Panel.

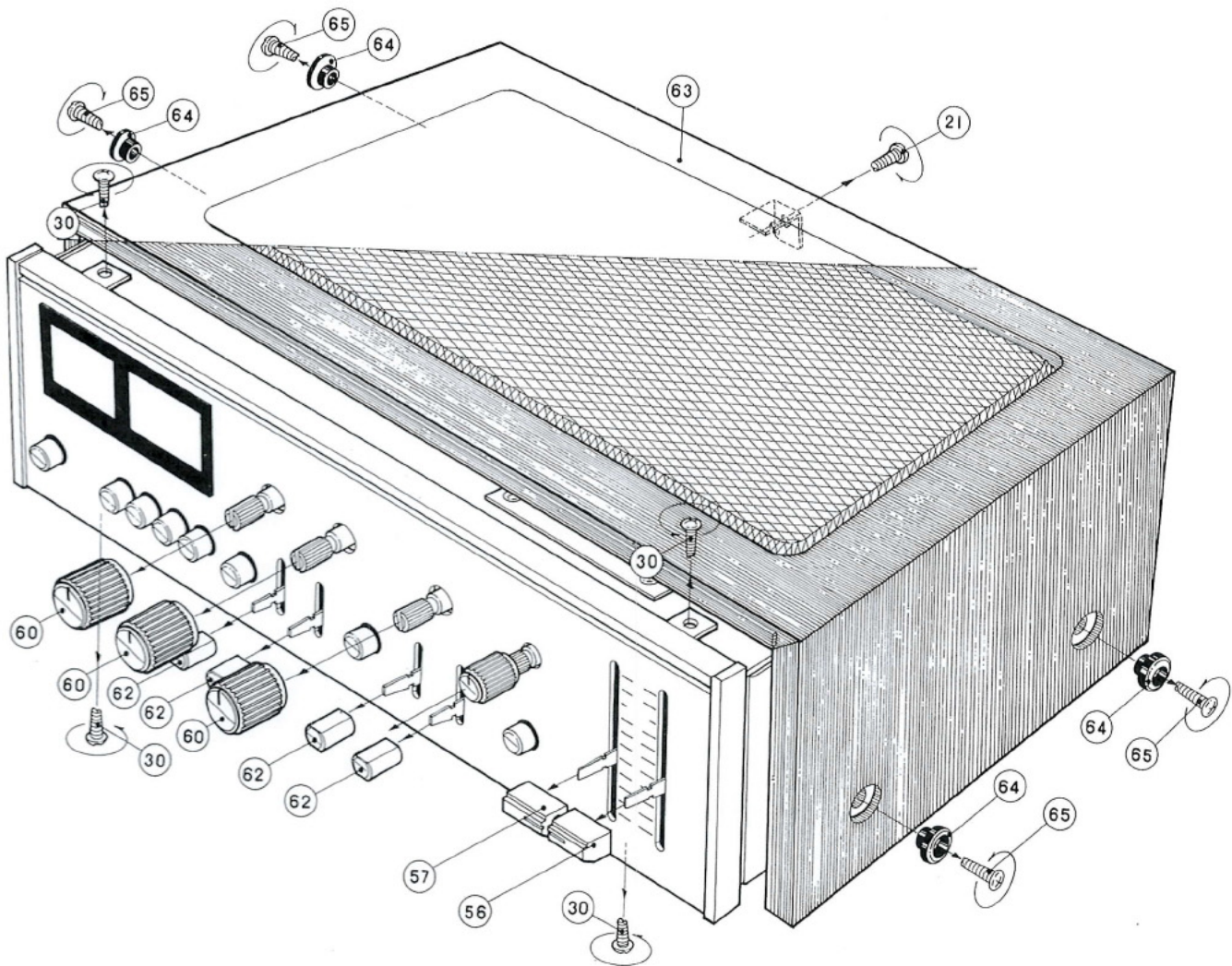

# BLOCK DIAGRAM

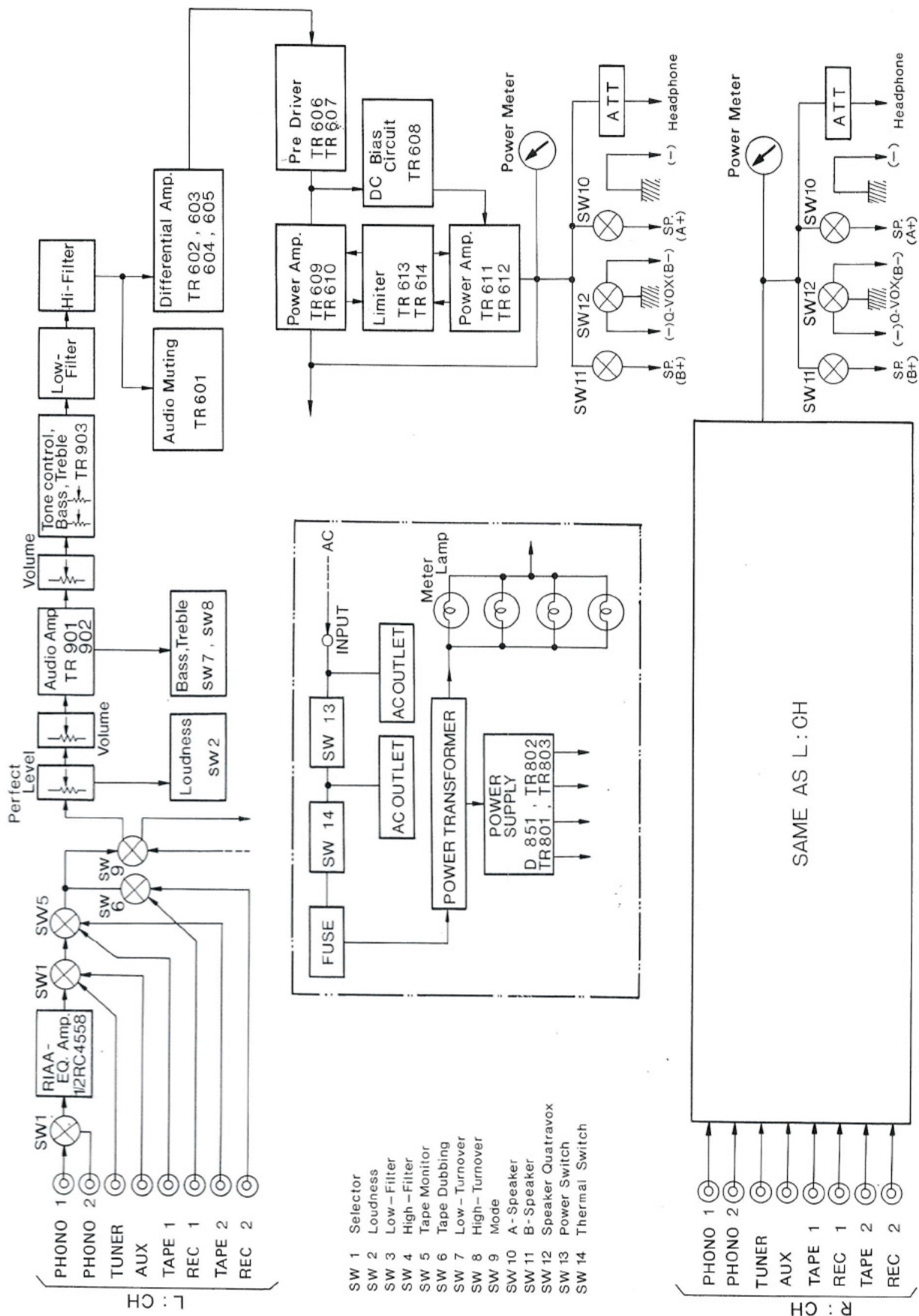

# ADJUSTMENT PROCEDURE

## MAIN AMPLIFIER

INDICATOR	ADJUSTMENT	REMARKS
DC Voltmeter	VR601a,b (1 K $\Omega$ /B)	Adjust for 0.06 ~ 0.075V across R629a,b (0.33 $\Omega$ ) with no signal.
POWER METER	VR602a,b (5 K $\Omega$ /B)	Adjust for 1 watt reading on POWER METER with speaker output of 2.82 V RMS at 1 kHz, 8 ohm load.

## ADJUSTMENT POINTS

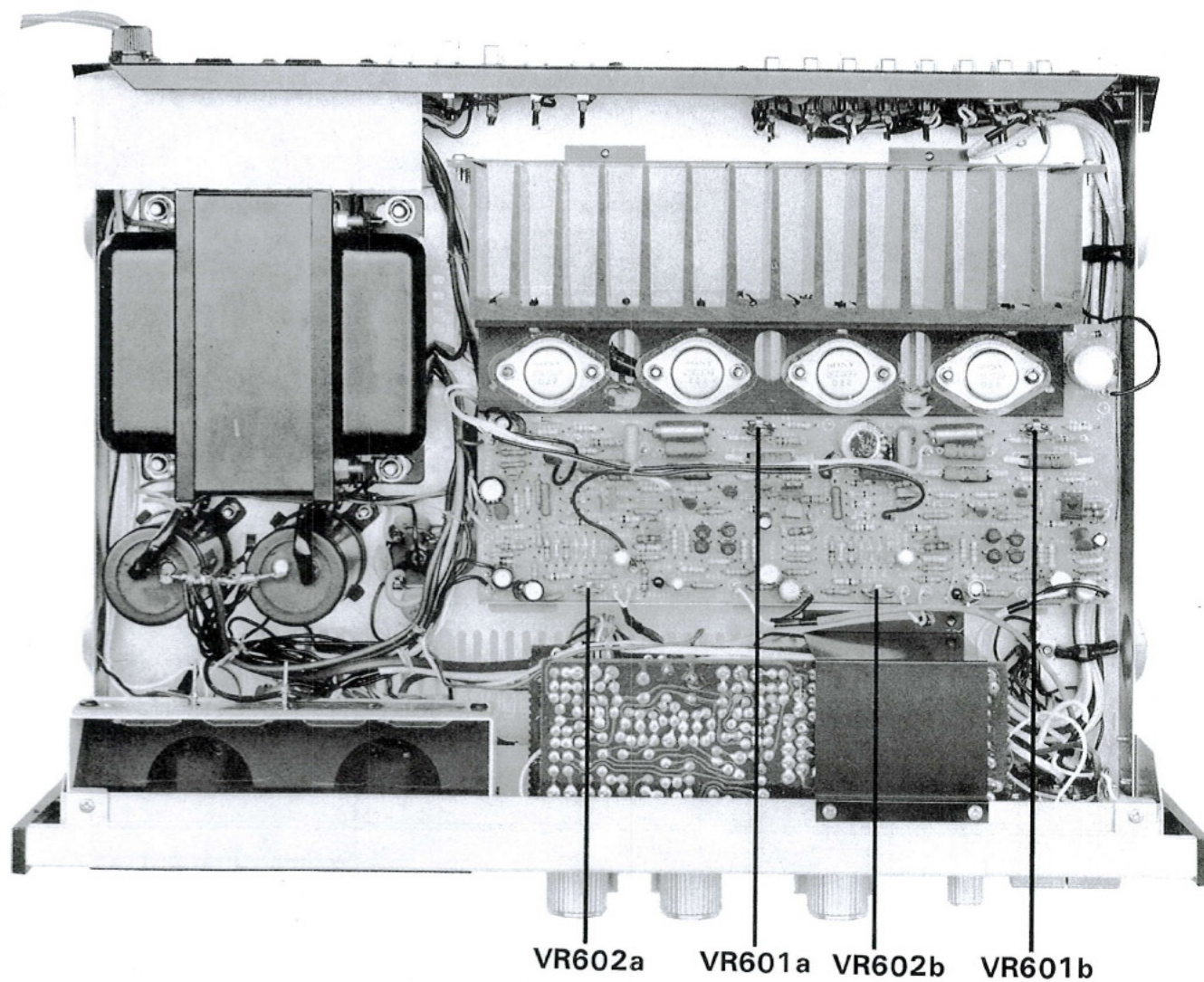

# TROUBLESHOOTING

Symptom	Cause and Remedy
1) Amplifier not operative; pilot lamp (behind the VU meters) does not light.	<ul style="list-style-type: none"> <li>A) Faulty AC power cord Replace the cord.</li> <li>B) Defect in power switch SW13 Replace the switch.</li> <li>C) Blown power fuse Replace the fuse.</li> <li>D) Defective thermal switch Replace the thermal switch.</li> </ul>
2) Fuse blows when power is turned ON.	<ul style="list-style-type: none"> <li>A) Power transformer T851 defective Replace the transformer.</li> <li>B) Short in the primary or secondary of the transformer circuitry Repair the short.</li> <li>C) Damaged rectifier D851 Replace the rectifier.</li> <li>D) Short circuit in the power supply circuit Repair the short.</li> <li>E) Short circuit in the power transistor TR610a,b or TR612a,b Replace the defective transistor(s) and check circuit.</li> </ul>
3) Pilot lamp lights but no sound from either channel.	<ul style="list-style-type: none"> <li>A) Resistor R917a,b or R918a,b damaged (open) Replace the damaged resistor(s).</li> <li>B) Capacitor C851 or C852 defective (short) Replace the defective capacitor(s).</li> <li>C) Rectifier D851 damaged (open) Replace the rectifier.</li> <li>D) Open in secondary winding of the power transformer T851 Replace the transformer.</li> </ul>
4) "A" speakers do not work.	<ul style="list-style-type: none"> <li>A) Speaker switch SW10 defective Replace the switch.</li> </ul>
5) "B" speakers do not work.	<ul style="list-style-type: none"> <li>A) Speaker switch SW11 defective Replace the switch.</li> </ul>
6) QUATRAVOX not effective	<ul style="list-style-type: none"> <li>A) Speaker switch SW12 defective Replace the switch.</li> </ul>
7) One channel does not work with VOLUME at maximum with a test signal applied to the center terminal of VOLUME control of the dead channel.	<ul style="list-style-type: none"> <li>A) Defect in transistor TR601-TR614 of Main Amp Board 6045 Locate and correct the defect.</li> <li>B) Defect in transistor TR901, TR902 or TR903 of Pre-Amp Board 5031 Replace the defective transistor(s).</li> <li>C) Short in speaker output terminal Repair the short.</li> <li>D) Defective resistor R901-R907, R914-R918, R601-R615, R617-R620 or R622-R634 Replace the defective resistor(s).</li> </ul>

Symptom	Cause and Remedy
8) Same as 7 above but channel operates when test signal is applied as 7.	A) Defective SELECTOR switch SW1 or TAPE MONITOR switch SW5 Repair or replace the defective switch(es). B) Faulty resistor R503, R504, R512 or R513 Replace the faulty one(s). C) Defective VOLUME control VR551 or PERFECT LEVEL control VR501 Replace the defective one(s). D) Poor contact in AUX or TUNER input jacks Repair or replace jack.
9) Same as 8 above but PHONO does not operate.	A) Poor contact in PHONO input jacks Repair or replace jacks. B) IC501 (RC4558) defective Replace the IC501. C) Resistor R503, R512 or R513 defective. Replace the defective one(s). D) Defective capacitor C501, C505, C510 or C511. Replace the defective one(s).
10) Same as 8 above but TUNER or AUX do not operate.	A) Poor contact in input jacks Repair or replace the jack(s). B) Defective SELECTOR switch SW1 Repair or replace the switch.
11) Speaker works normally but headphones do not work.	A) Headphone plug does not mate with jack. Replace the plug. B) Defective resistor R651a,b Replace the resistor(s).
12) TAPE OUT not operative	A) Poor contact in TAPE OUT output jack Repair or replace the jack. B) Defective resistor R701 or R702 (open). Replace the defective resistor(s). C) Defective TAPE DUBBING Switch Replace the switch.
13) PERFECT LOUDNESS has no effect.	A) Defective DEFEAT switch SW2 Replace the switch. B) Defective capacitor C701. Replace the capacitor. C) Defective VOLUME control VR551 or VR552. Replace.
14) STEREO-MONO not effective	A) Defective MONO switch SW9 Replace the switch.
15) TAPE MONITOR not effective	A) Defective TAPE MONITOR switch SW5 Replace the switch. B) Poor contact in TAPE IN input jacks Repair or replace jacks.



Symptom	Cause and Remedy
16) BASS control has no effect.	A) VR902 defective Replace the variable resistor. B) Defective C702, C703, C704 or C705 of Push Switch Board 7130 Replace the defective one(s). C) Defective turn-over switch SW7 Replace the switch.
17) TREBLE control has no effect.	A) VR901 defective Replace the variable resistor. B) Defective C706, C707 or C708 of Push Switch Board 7130 Replace the defective one(s). C) Defective turn-over switch SW8 Replace the switch.
18) Excessive noise with PHONO input.	A) Faulty IC501 Replace the IC. B) Defective resistor R501-R510 or capacitor C501-C505 Replace the defective component(s).
19) LO-FIL not effective	A) Defective LO-FIL switch SW3 Replace the switch. B) Resistor R710 or capacitor C709 defective. Replace the defective component(s).
20) HI-FIL not effective.	A) Defective HI-FIL switch SW4 Replace the switch. B) Capacitor C710 or resistor R712 defective. Replace the defective component(s).
21) Noisy VOLUME control	A) Defective VOLUME control VR551 or VR552 Replace. B) Defective capacitor C505 (PHONO only) or C901 Replace the defective one(s).
22) POWER METER(S) not functioning	A) POWER METER defective Replace the meter. B) Defective diode D605-D608 Replace the defective diode(s). C) Resistor R641 or R645 defective Replace the defective resistor(s).

NOTE: 1. This Amplifier has built-in over load thermal protection for abnormal operation. When the temperature of the thermal protector (installed with heat sink) does rise abnormally ( $90 \pm 5^\circ\text{C}$ ), the thermal protector will automatically cut out, and as soon as the temperature goes down sufficiently ( $35 \pm 15^\circ\text{C}$ ), the thermal protector turns back on automatically. If the Receiver does turn itself off, check ventilation and speaker connections.

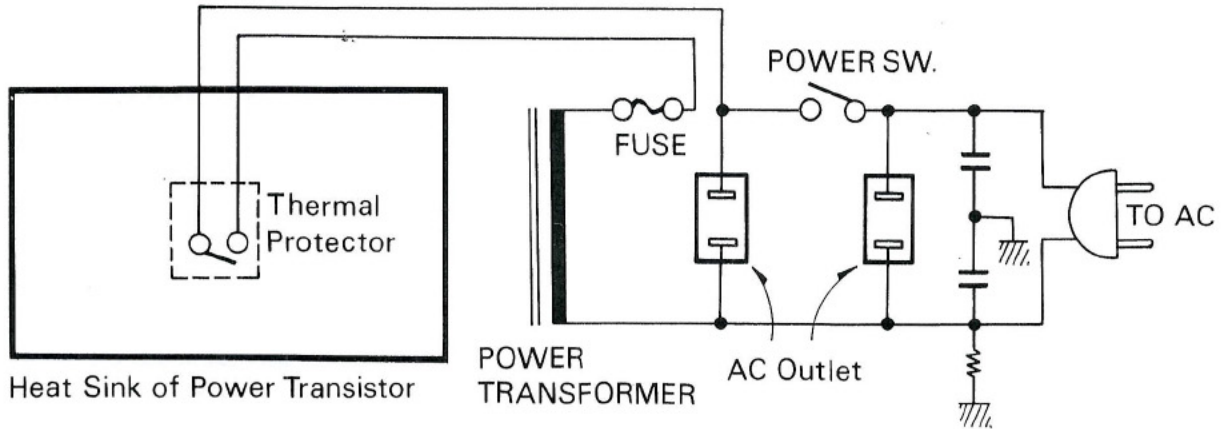

2. Transistors TR613 and TR614 protect the audio output stage when abnormally high current flows through TR610 and TR612, caused by excessive drive at input, or too low impedance load is connected at output. If increase of the current is excessive, the voltage across R629 and R630 will turn on TR613 and TR614 which are normally not biased "on". The collector potential of these transistors (through D601 and D602 diodes) reduce bias on TR609 and TR611, which causes output transistor current (TR610 and TR612) to reduce.

This performs two safety functions.

1. Protects the output circuit devices.
2. Protects the speakers from loud clicks, pops and excessive levels.

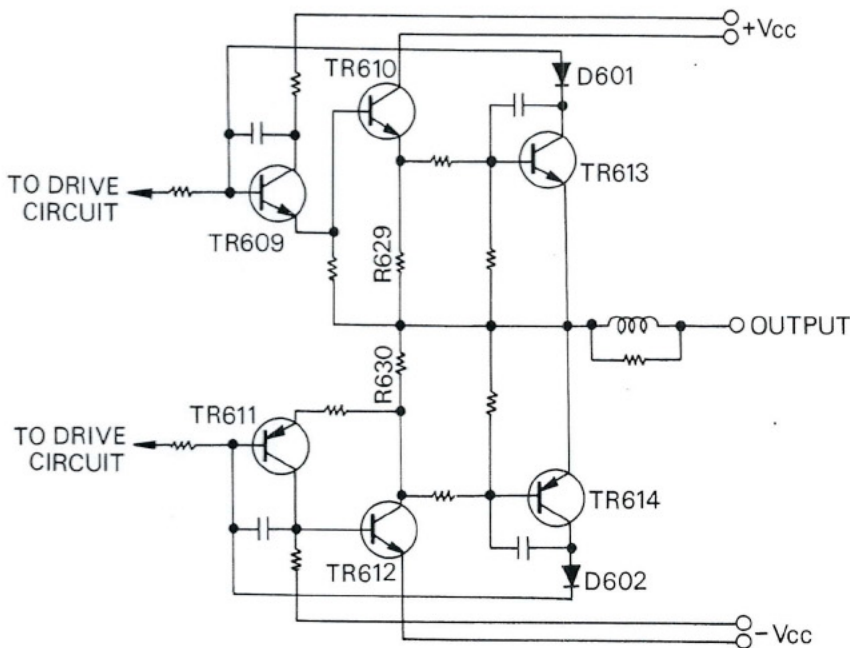

# LEVEL DIAGRAM

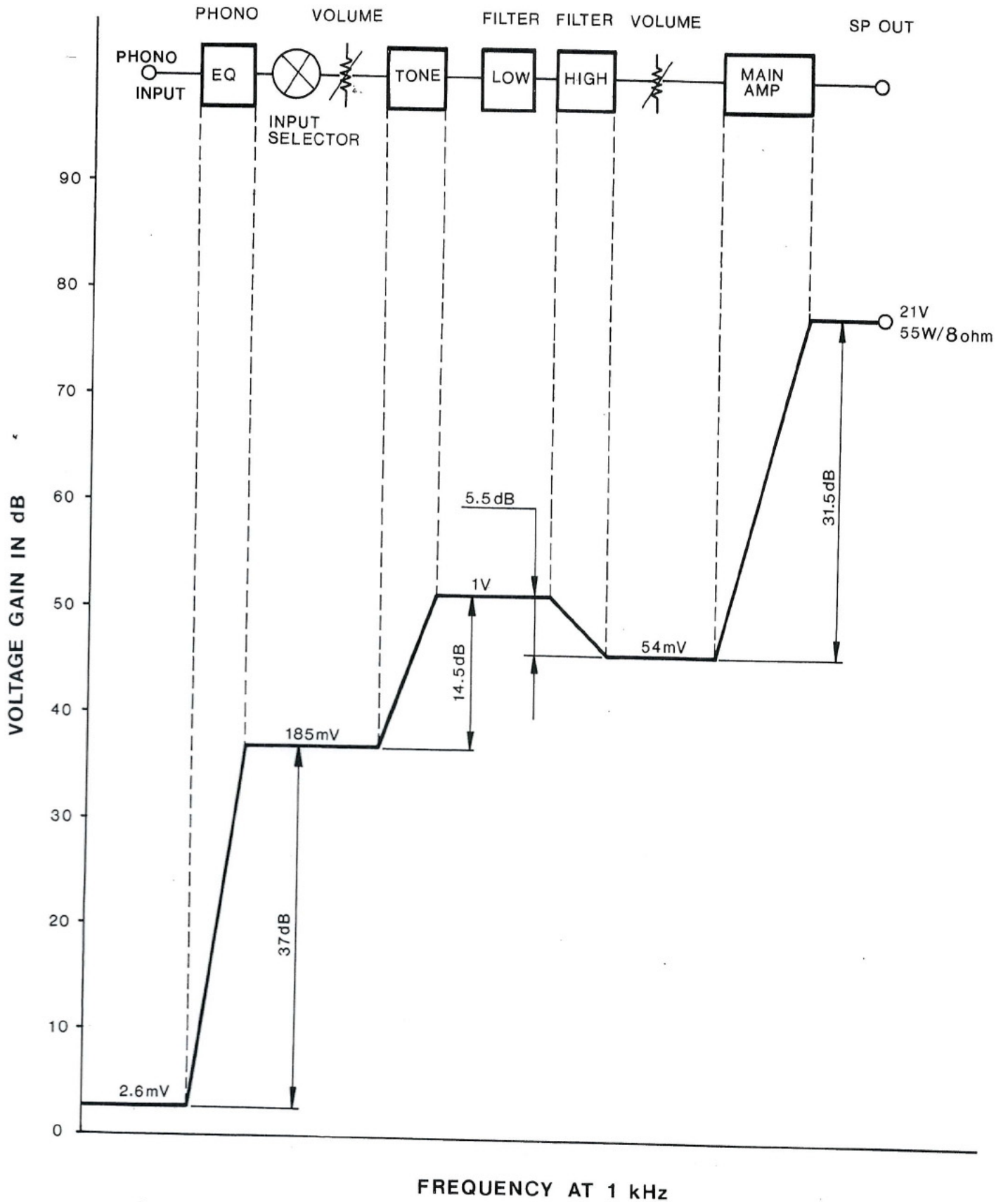

# 5031 PRE-AMP & TONE CONTROL BOARD

(TOP VIEW)

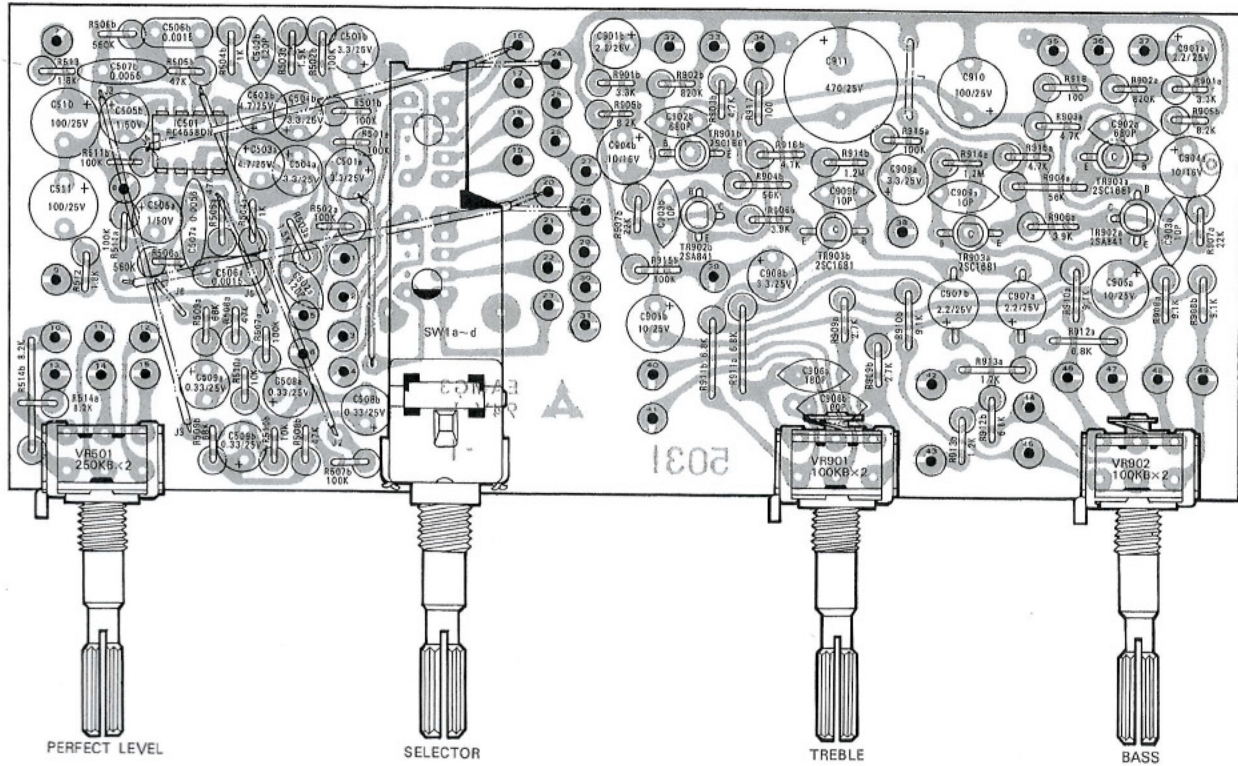

# 5031 PRE-AMP & TONE CONTROL BOARD

(BOTTOM VIEW)

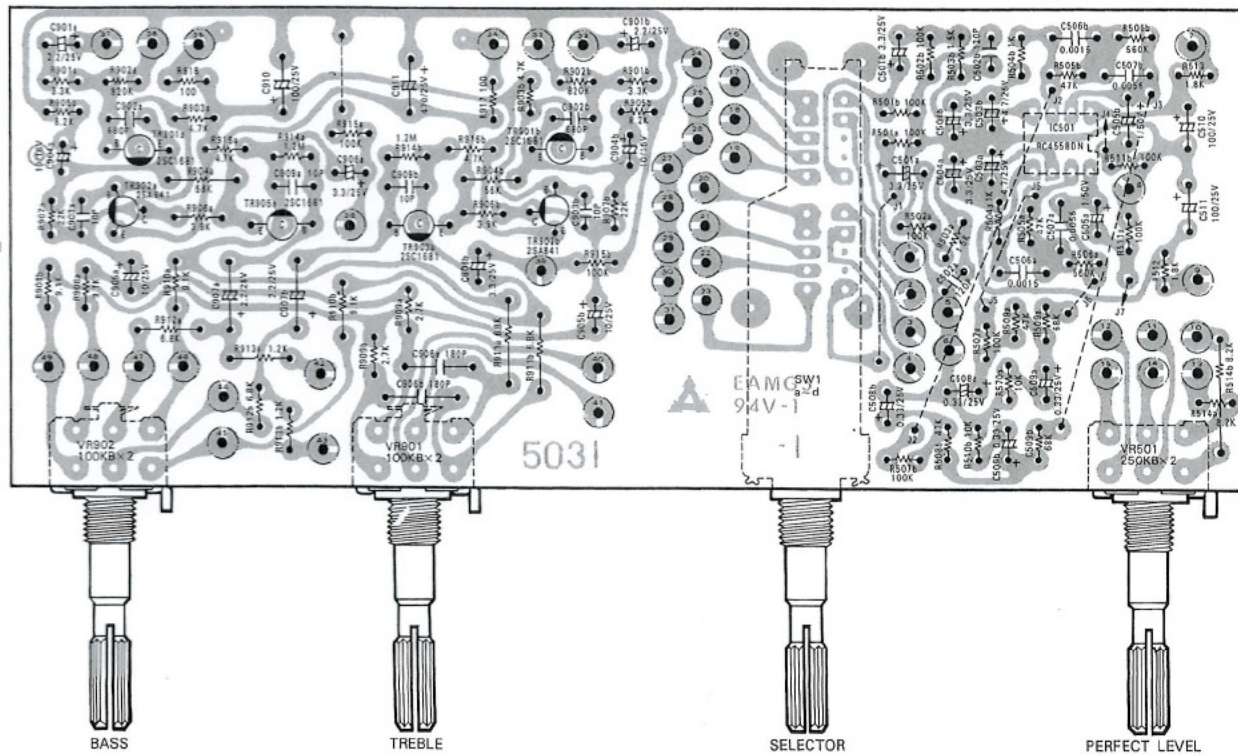

# 6045 MAIN AMP BOARD (TOP VIEW)

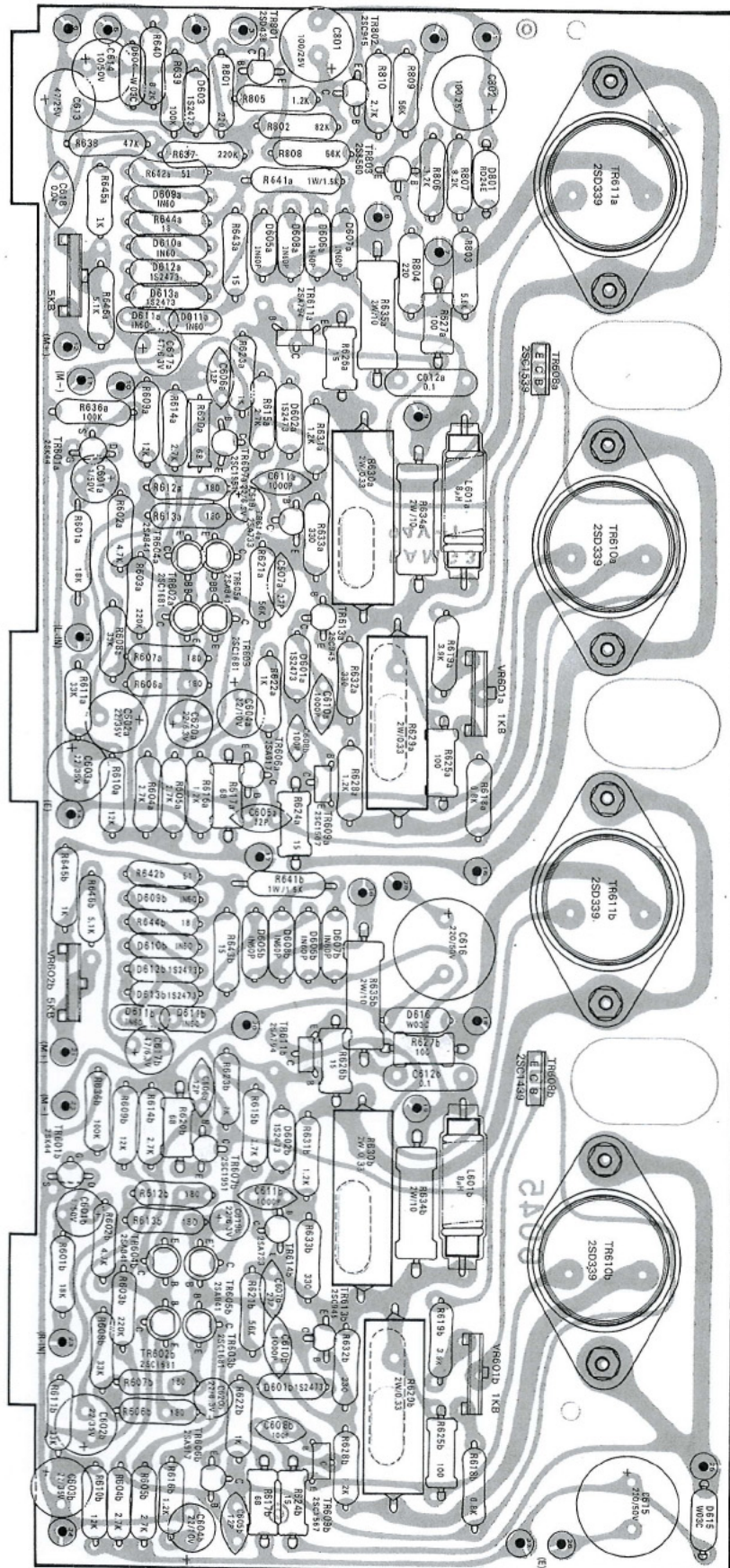

# 6045 MAIN AMP BOARD (BOTTOM VIEW)

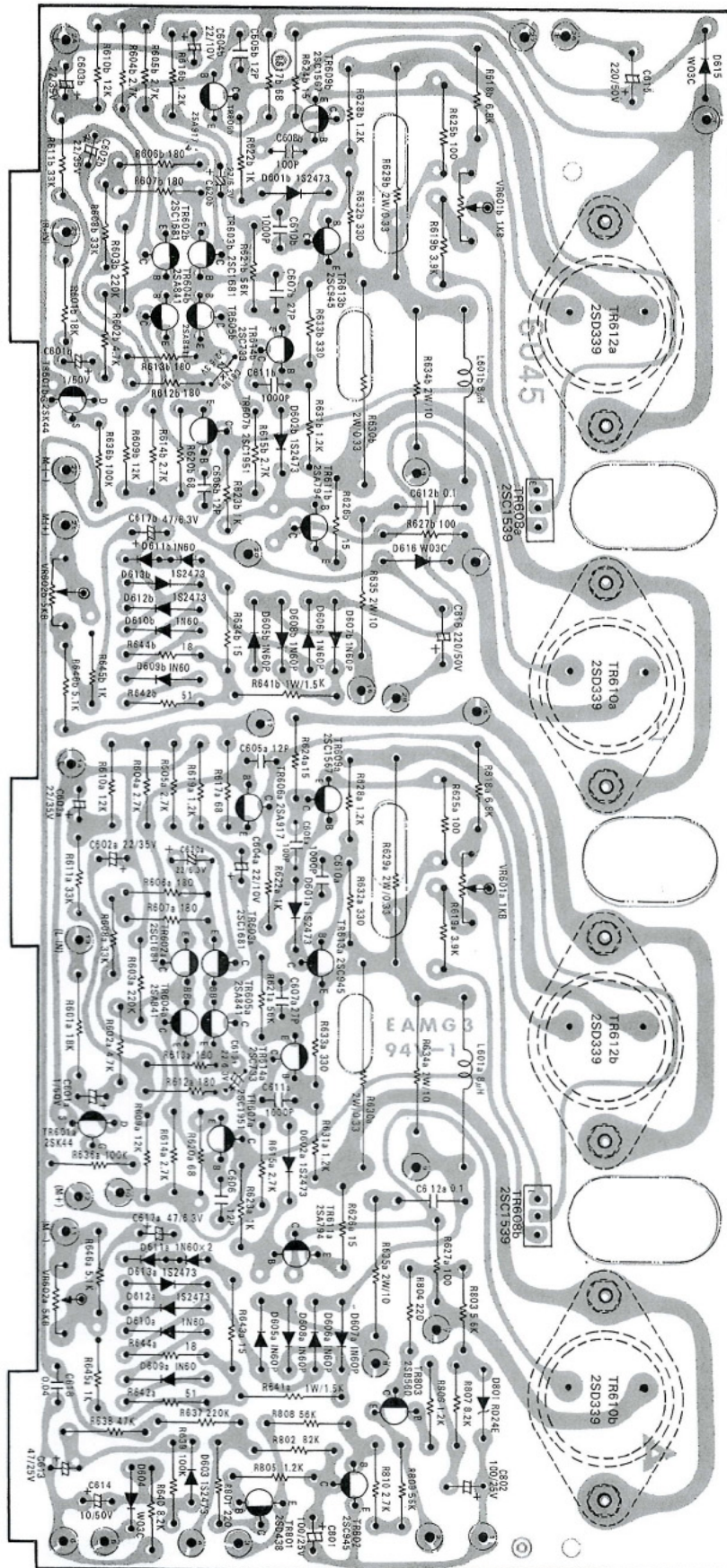

# 7129 PUSH SWITCH BOARD (TOP VIEW)

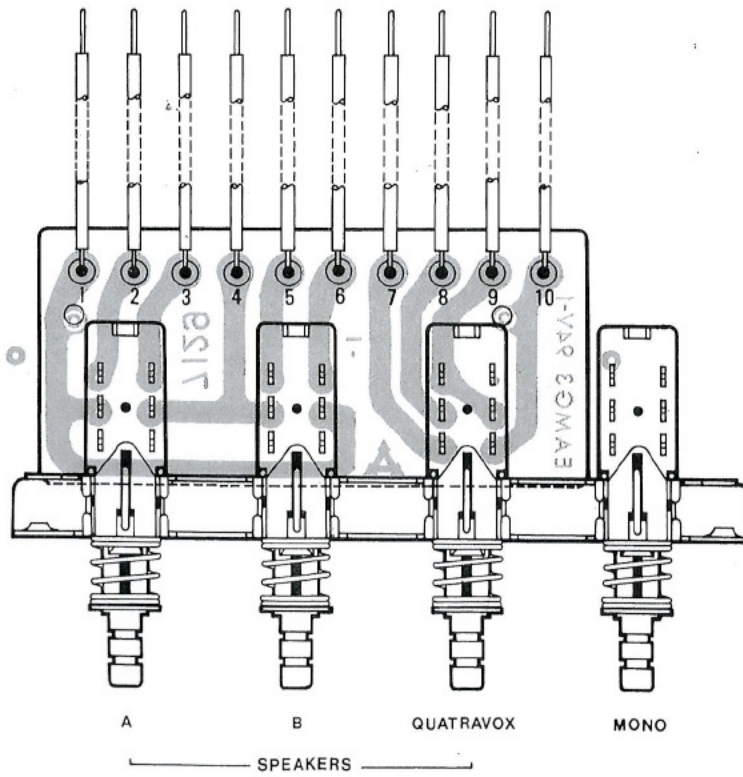

# 7129 PUSH SWITCH BOARD (BOTTOM VIEW)

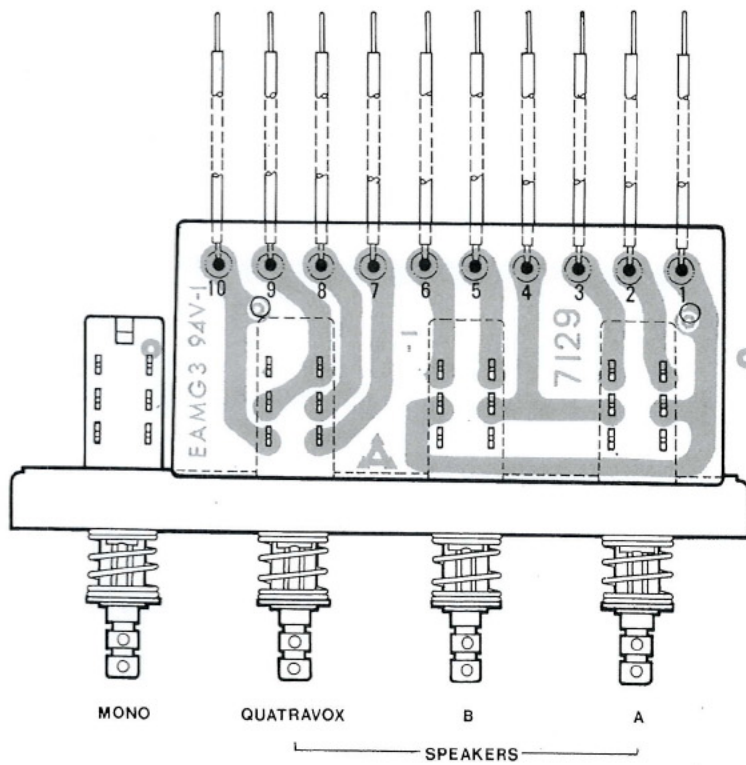

# 7130 TAPE & TONE SWITCH BOARD (TOP VIEW)

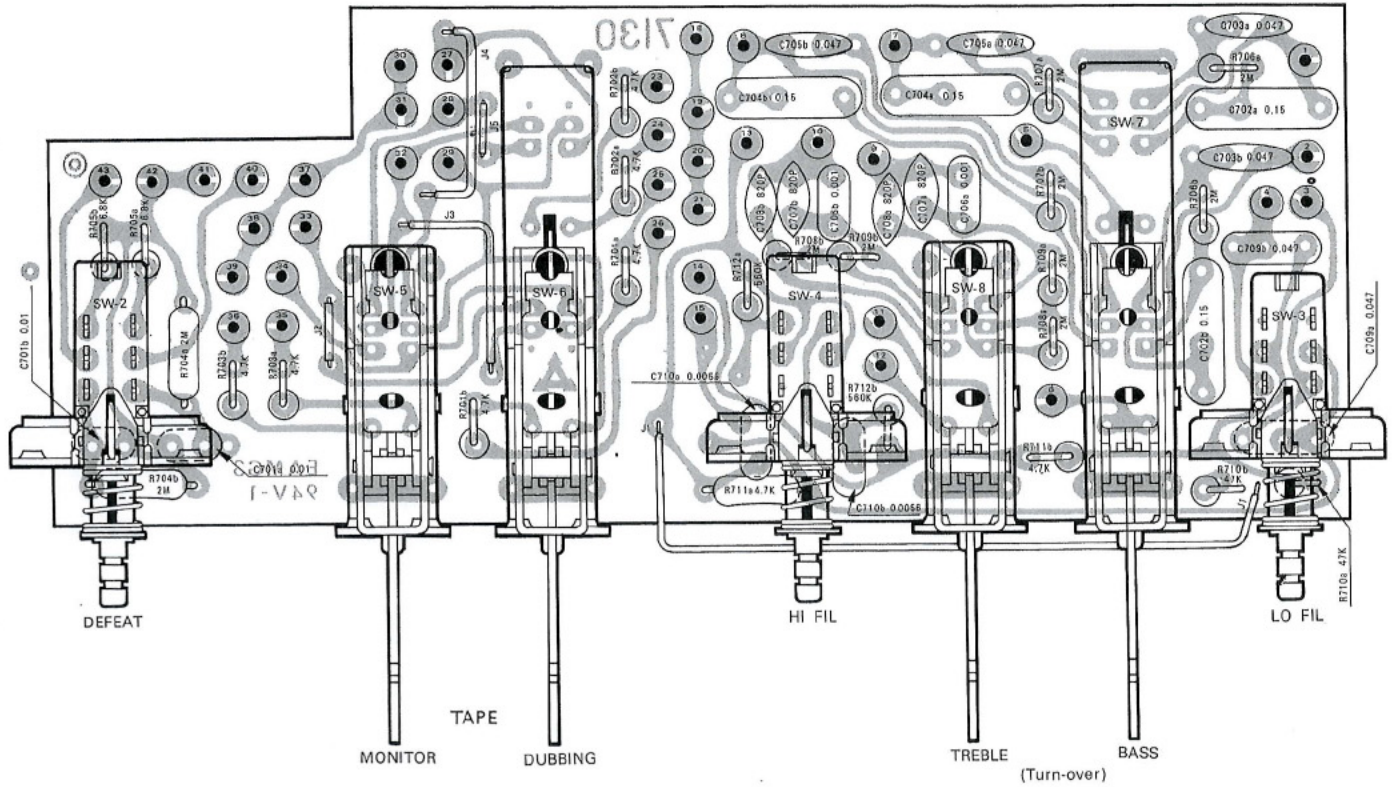

# 7130 TAPE & TONE SWITCH BOARD (BOTTOM VIEW)

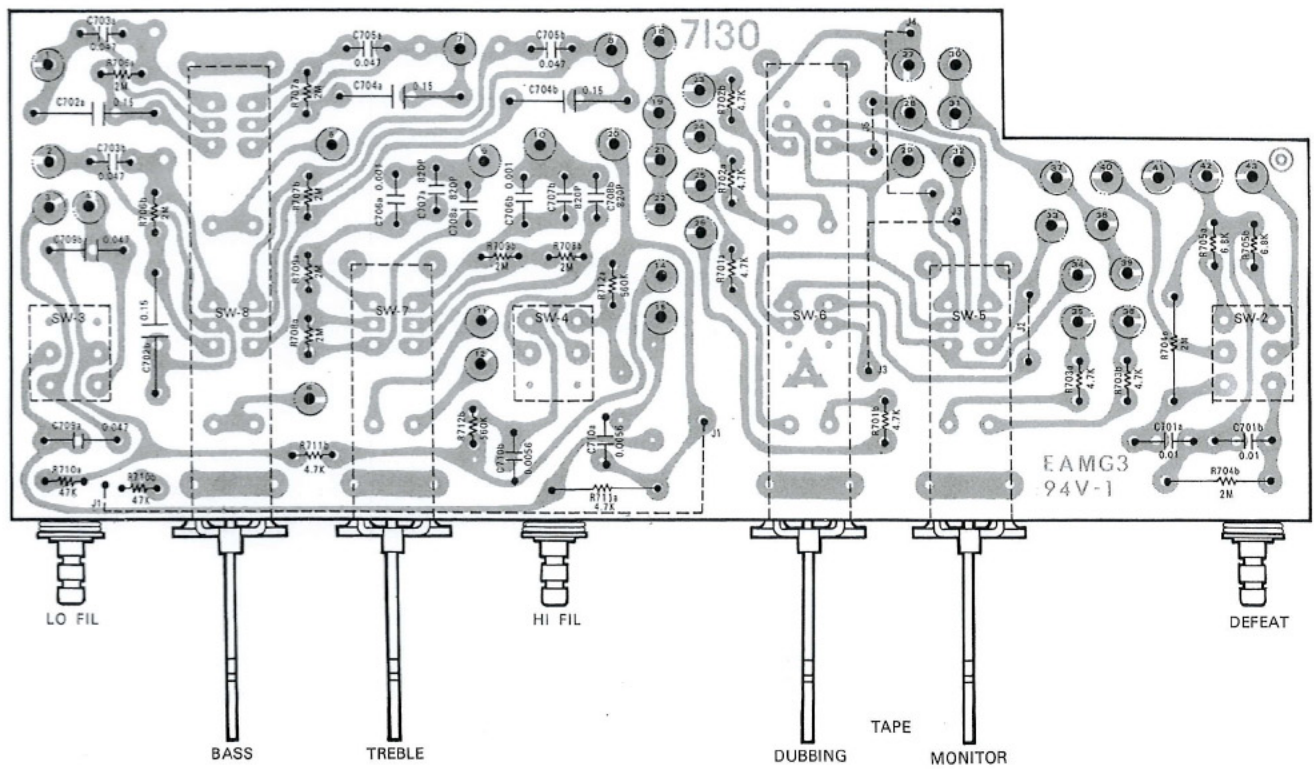



# SEMICONDUCTOR LEAD IDENTIFICATIONS

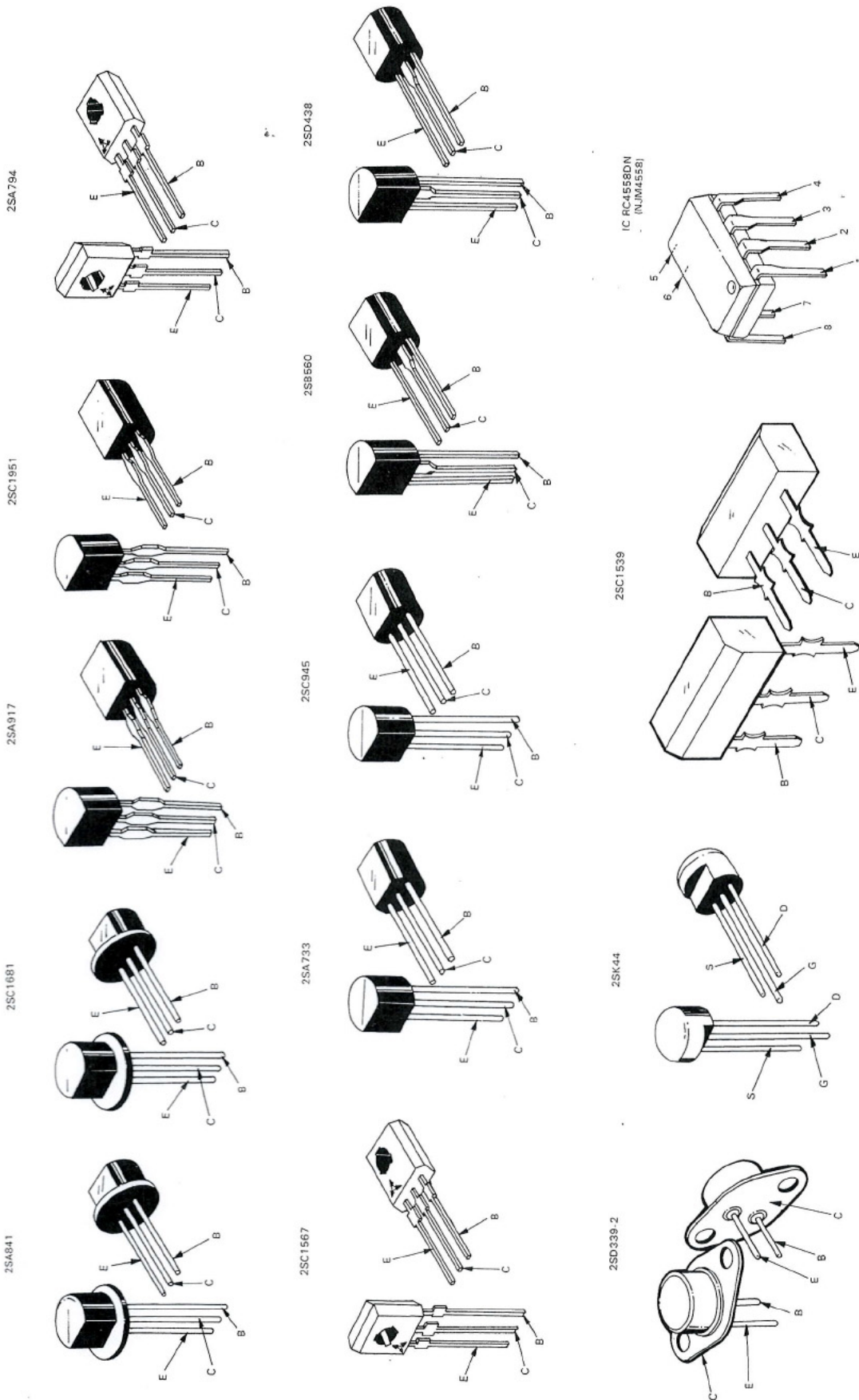

# ELECTRICAL PARTS LIST

CAPACITORS					Ref. No.	Value (F)	Voltage	Tolerance (%)	Material
Ref. No.	Value (F)	Voltage	Tolerance (%)	Material					
C501a,b	3.3 $\mu$	25	$\pm 20$	Electrolytic	C708a,b	820P	50	$\pm 10$	Polyester
C502a,b	120P	50	$\pm 5$	Ceramic	C709a,b	0.047 $\mu$	50	$\pm 5$	Polyester
C503a,b	4.7 $\mu$	25	+75 -10	Electrolytic	C710a,b	5600P	50	$\pm 5$	Polyester
C504a,b	3.3 $\mu$	25	+75 -10	Electrolytic	C801	100 $\mu$	25	+50 -10	Electrolytic
C505a,b	1 $\mu$	50	+75 -10	Electrolytic	C802	100 $\mu$	25	+50 -10	Electrolytic
C506a,b	1500P	50	$\pm 5$	Polyester	C851	8000 $\mu$	50	+50 -10	Electrolytic
C507a,b	5600P	50	$\pm 5$	Polyester	C852	8000 $\mu$	50	+50 -10	Electrolytic
C508a,b	0.33 $\mu$	25	$\pm 20$	Electrolytic	C853	0.01 $\mu$	500	+80 -20	Ceramic
C509a,b	0.33 $\mu$	25	$\pm 20$	Electrolytic	C854	0.01 $\mu$	500	+80 -20	Ceramic
C510	100 $\mu$	25	+50 -10	Electrolytic	C855	0.01 $\mu$	500	+80 -20	Ceramic
C511	100 $\mu$	25	+50 -10	Electrolytic	C856	0.01 $\mu$	500	+80 -20	Ceramic
C551	0.022 $\mu$	25	+80 -20	Ceramic	C857	4700P	125	$\pm 20$	Polyester
C552	0.82 $\mu$	50	$\pm 10$	Ceramic	C858	4700P	125	$\pm 20$	Polyester
C553	0.82 $\mu$	50	$\pm 10$	Ceramic	C901a,b	2.2 $\mu$	25	$\pm 20$	Electrolytic
C554	0.022 $\mu$	25	+80 -20	Ceramic	C902a,b	680P	50	$\pm 10$	Ceramic
C555	0.022 $\mu$	25	+80 -20	Ceramic	C903a,b	10P	50	$\pm 10$	Ceramic
C556	0.1 $\mu$	50	$\pm 5$	Polyester	C904a,b	10 $\mu$	16	+50 -10	Electrolytic
C601a,b	1 $\mu$	50	+75 -10	Electrolytic	C905a,b	10 $\mu$	25	+50 -10	Electrolytic
C602a,b	22 $\mu$	35	+50 -10	Electrolytic	C906a,b	180P	50	$\pm 10$	Ceramic
C603a,b	22 $\mu$	35	+50 -10	Electrolytic	C907a,b	2.2 $\mu$	25	$\pm 20$	Electrolytic
C604a,b	22 $\mu$	10	+50 -10	Electrolytic	C908a,b	3.3 $\mu$	25	$\pm 20$	Electrolytic
C605a,b	12P	50	$\pm 10$	Ceramic	C909a,b	10P	50	$\pm 10$	Ceramic
C606a,b	12P	50	$\pm 10$	Ceramic	C910	100 $\mu$	25	+50 -10	Electrolytic
C607a,b	27P	50	$\pm 10$	Ceramic	C911	470 $\mu$	25	+50 -10	Electrolytic
C608a,b	100P	50	$\pm 10$	Ceramic					
C609a,b	100P	50	$\pm 10$	Ceramic					
C610a,b	1000P	50	$\pm 10$	Ceramic					
C611a,b	1000P	50	$\pm 10$	Ceramic					
C612a,b	0.1 $\mu$	50	$\pm 10$	Ceramic					
C613	47 $\mu$	25	+50 -10	Electrolytic					
C614	10 $\mu$	50	+50 -10	Electrolytic					
C615	220 $\mu$	50	+50 -10	Electrolytic					
C616	220 $\mu$	50	+50 -10	Electrolytic					
C617a,b	47 $\mu$	6.3	+50 -10	Electrolytic					
C618	0.04 $\mu$	25	+80 -20	Ceramic					
C619a,b	22 $\mu$	6.3	+50 -10	Electrolytic					
C620a,b	22 $\mu$	6.3	+50 -10	Electrolytic					
C651a,b	100P	50	$\pm 10$	Ceramic					
C701a,b	0.01 $\mu$	50	$\pm 5$	Polyester					
C702a,b	0.15 $\mu$	50	$\pm 5$	Polyester					
C703a,b	0.047 $\mu$	50	$\pm 5$	Polyester					
C704a,b	0.15 $\mu$	50	$\pm 5$	Polyester					
C705a,b	0.047 $\mu$	50	$\pm 5$	Polyester					
C706a,b	1000P	50	$\pm 5$	Polyester					
C707a,b	820P	50	$\pm 10$	Polyester					

<b>COIL</b>						
Ref. No.	Description			R/S Part No.	Mfr's Part No.	
L601a,b	Choke Coil 3 $\mu$ H			CB-2299	35500300	
<b>DIODES</b>						
Ref. No.	Type No.	R/S Part No.	Part No.	Manufacturer	Remarks	
D601a,b	1S2473		30600410	Toyo Electronics	50V, 100mA	
D602a,b	1S2473		30600410	Toyo Electronics	50V, 100mA	
D603	1S2473		30600410	Toyo Electronics	50V, 100mA	
D604	W03C		30600871	Hitachi	200V, 1A	
D605a,b	1N60P		30600011	UNISON	35V, 50mA	
D606a,b	1N60P		30600011	UNISON	35V, 50mA	
D607a,b	1N60P		30600011	UNISON	35V, 50mA	
D608a,b	1N60P		30600011	UNISON	35V, 50mA	
D609a,b	1N60		30600010	UNISON	35V, 50mA	
D610a,b	1N60		30600010	UNISON	35V, 50mA	
D611a,b	1N60		30600010	UNISON	35V, 50mA	
D612a,b	1S2473		30600410	Toyo Electronics	50V, 100mA	
D613a,b	1S2473		30600410	Toyo Electronics	50V, 100mA	
D614a,b	1N60		30600010	UNISON	35V, 50mA	
D615	W03C		30600871	Hitachi	200V, 1A	
D616	W03C		30600871	Hitachi	200V, 1A	
D801	RD24E		30600781	NEC	Zener, 24V, 400mW	
D851	S5VB		30600981	Shindengen	Bridged Diode 200V, 6A	
<b>INTEGRATED CIRCUIT</b>						
Ref. No.	Type No.	R/S Part No.	Mfr's Part No.	Manufacturer	Substitute	
					Type No.	Manufacturer
IC501	RC4558DN		30900360	RAYTHEON	NJM4558	JRC
<b>METER</b>						
Ref. No.	Description			R/S Part No.	Mfr's Part No.	
M1a,b	POWER METER			M-0330	60500002	
<b>P.C.BOARDS (ASSEMBLED)</b>						
Ref. No.	Description			R/S Part No.	Mfr's Part No.	
5031	PRE-AMP & TONE CONTROL BOARD			X-7317	97503110	
6045	MAIN AMP BOARD			X-7316	97604510	
7129	PUSH SWITCH BOARD			S-7299	97712910	
7130	TAPE & TONE SWITCH BOARD			X-7315	97713010	
7132	METER LAMP BOARD			X-7314	97713210	

# POWER TRANSFORMER

Ref. No.	Description	R/S Part No.	Mfr's Part No.
T851	(for UL) (for CSA) (for Europe/Australia)	TA-0596	35900226 35900227 35900228

## RESISTORS

Ref. No.	Value ( $\Omega$ )	Wattage	Tolerance (%)	Material	Ref. No.	Value ( $\Omega$ )	Wattage	Tolerance (%)	Material
R501a,b	100K	1/4	±5	Carbon	R628a,b	1.2K	1/4	±5	Carbon
R502a,b	100K	1/4	±5	Carbon	R629a,b	0.33	2	±5	Metal Oxide
R503a,b	1.5K	1/4	±5	Carbon	R630a,b	0.33	2	±5	Metal Oxide
R504a,b	1K	1/4	±5	Carbon	R631a,b	1.2K	1/4	±5	Carbon
R505a,b	47K	1/4	±5	Carbon	R632a,b	330	1/4	±5	Carbon
R506a,b	560K	1/4	±5	Carbon	R633a,b	330	1/4	±5	Carbon
R507a,b	100K	1/4	±5	Carbon	R634a,b	10	2	±5	Metal Oxide
R508a,b	47K	1/4	±5	Carbon	R635a,b	10	2	±5	Metal Oxide
R509a,b	68K	1/4	±5	Carbon	R636a,b	100K	1/4	±5	Carbon
R510a,b	10K	1/4	±5	Carbon	R637	220K	1/4	±5	Carbon
R511a,b	100K	1/4	±5	Carbon	R638	47K	1/4	±5	Carbon
R512	1.8K	1/4	±5	Carbon	R639	100K	1/4	±5	Carbon
R513	1.8K	1/4	±5	Carbon	R640	8.2K	1/4	±5	Carbon
R514a,b	8.2K	1/4	±5	Carbon	R641a,b	1.5K	1	±5	Metal Oxide
R601a,b	18K	1/4	±5	Carbon	R642a,b	51	1/4	±5	Carbon
R602a,b	4.7K	1/4	±5	Carbon	R643a,b	15	1/4	±5	Carbon
R603a,b	220K	1/4	±5	Carbon	R644a,b	18	1/4	±5	Carbon
R604a,b	2.7K	1/4	±5	Carbon	R645a,b	820	1/4	±5	Carbon
R605a,b	2.7K	1/4	±5	Carbon	R646a,b	5.1K	1/4	±5	Carbon
R606a,b	180	1/4	±5	Carbon	R651a,b	470	1/2	±10	Solid
R607a,b	180	1/4	±5	Carbon	R701a,b	4.7K	1/4	±5	Carbon
R608a,b	33K	1/4	±5	Carbon	R702a,b	4.7K	1/4	±5	Carbon
R609a,b	12K	1/4	±5	Carbon	R703a,b	4.7K	1/4	±5	Carbon
R610a,b	12K	1/4	±5	Carbon	R704a,b	2M	1/4	±5	Carbon
R611a,b	33K	1/4	±5	Carbon	R705a,b	6.8K	1/4	±5	Carbon
R612a,b	180	1/4	±5	Carbon	R706a,b	2M	1/4	±5	Carbon
R613a,b	180	1/4	±5	Carbon	R707a,b	2M	1/4	±5	Carbon
R614a,b	2.7K	1/4	±5	Carbon	R708a,b	2M	1/4	±5	Carbon
R615a,b	2.7K	1/4	±5	Carbon	R709a,b	2M	1/4	±5	Carbon
R616a,b	1.2K	1/4	±5	Carbon	R710a,b	47K	1/4	±5	Carbon
R617a,b	68	1/4	±5	Carbon	R711a,b	4.7K	1/4	±5	Carbon
R618a,b	6.8K	1/4	±5	Carbon	R712a,b	560K	1/4	±5	Carbon
R619a,b	3.9K	1/4	±5	Carbon	R801	220	1/4	±5	Carbon
R620a,b	68	1/4	±5	Carbon	R802	82K	1/4	±5	Carbon
R621a,b	56K	1/4	±5	Carbon	R803	5.6K	1/4	±5	Carbon
R622a,b	1K	1/4	±5	Carbon	R804	220	1/4	±5	Carbon
R623a,b	1K	1/4	±5	Carbon	R805	1.2K	1/4	±5	Carbon
R624a,b	15	1/4	±5	Carbon	R806	1.2K	1/4	±5	Carbon
R625a,b	100	1/4	±5	Carbon	R807	8.2K	1/4	±5	Carbon
R626a,b	15	1/4	±5	Carbon	R808	56K	1/4	±5	Carbon
R627a,b	100	1/4	±5	Carbon					

Ref. No.	Value ( $\Omega$ )	Wattage	Tolerance (%)	Material	Ref. No.	Value ( $\Omega$ )	Wattage	Tolerance (%)	Material
R809	56K	1/4	$\pm 5$	Carbon	R908a,b	9.1K	1/4	$\pm 5$	Carbon
R810	2.7K	1/4	$\pm 5$	Carbon	R909a,b	2.7K	1/4	$\pm 5$	Carbon
R851	2.2M	1/2	$\pm 10$	Solid	R910a,b	9.1K	1/4	$\pm 5$	Carbon
R901a,b	3.3K	1/4	$\pm 5$	Carbon	R911a,b	6.8K	1/4	$\pm 5$	Carbon
R902a,b	820K	1/4	$\pm 5$	Carbon	R912a,b	6.8K	1/4	$\pm 5$	Carbon
R903a,b	4.7K	1/4	$\pm 5$	Carbon	R913a,b	1.2K	1/4	$\pm 5$	Carbon
R904a,b	56K	1/4	$\pm 5$	Carbon	R914a,b	1.2M	1/4	$\pm 5$	Carbon
R905a,b	8.2K	1/4	$\pm 5$	Carbon	R915a,b	100K	1/4	$\pm 5$	Carbon
R906a,b	3.9K	1/4	$\pm 5$	Carbon	R916a,b	4.7K	1/4	$\pm 5$	Carbon
R907a,b	22K	1/4	$\pm 5$	Carbon	R917	100	1/4	$\pm 5$	Carbon
					R918	100	1/4	$\pm 5$	Carbon

## SWITCHES

Ref. No.	Description	R/S Part No.	Mfr's Part No.
SW1a-d	SELECTOR SRZ-V044N	S-0757	27100140
SW2	DEFEAT	S-7297	27200091
SW3	LO-FIL	S-7298	27200090
SW4	HI-FIL	S-7298	27200090
SW5	TAPE MONITOR	S-5041	27600028
SW6	TAPE DUBBING	S-5042	27600026
SW7	BASS (Turn-over)		27600026
SW8	TREBLE (Turn-over)		27600028
SW9-SW12	4-switch(SPEAKERS and MONO)	S-0799	27200092
SW13	POWER TV-5 (UL)	S-7296	27200082
SW14	Thermal Protector 90C	HB-4796	30700180

## TRANSISTORS

Ref. No.	Type No.	Manufacturer	Mfr's Part No.	Substitute	
				Type No.	Manufacturer
TR601a,b	2SK44	Sanyo	30400102	2SK30	Toshiba
TR602a,b	2SC1681(BL)	Toshiba	30201132	2SC1222	NEC
TR603a,b	2SC1681(BL)	Toshiba	30201132	2SC1222	NEC
TR604a,b	2SA841(BL)	Toshiba	30000442	2SA640	NEC
TR605a,b	2SA841(BL)	Toshiba	30000442	2SA640	NEC
TR606a,b	2SA917	Sony	30000511	2SA899	Fujitsu
TR607a,b	2SC1951	Sony	30201261	2SC1904	Fujitsu
TR608a,b	2SC1539	Toyo Electronics	30200921	2SC1537	Toyo Electronics
TR609a,b	2SC1567(R)	Matsushita	30201023	2SD600	Sanyo
TR610a,b	2SD339(2)	Sony	30300201	2SC1403,2SD426	Sanken, Toshiba
TR611a,b	2SA794(R)	Matsushita	30000413	2SC1116	Sanken
TR612a,b	2SD339(2)	Sony	30300201	2SB631	Sanyo
TR613a,b	2SC945(L-P)	NEC	30200522	2SC1403, 2SD426	Sanken, Toshiba
TR614a,b	2SA733(Q)	NEC	30000423	2SC1116	Sanken
TR801	2SD438	Sanyo	30300250	2SC536	Sanyo
TR802	2SC945(L-P)	NEC	30200522	2SA608	Sanyo
TR803	2SB560	Sanyo	30100041	2SC1509	Matsushita
				2SC536	Sanyo
				2SA777	Matsushita

Ref. No.	Type No.	Manufacturer	Mfr's Part No.	Substitute	
				Type No.	Manufacturer
TR901a,b	2SC1681(BL)	Toshiba	30201132	2SC1222	NEC
TR902a,b	2SA841(BL)	Toshiba	30000442	2SA640	NEC
TR903a,b	2SC1681(BL)	Toshiba	30201132	2SC1222	NEC

## VARIABLE RESISTORS

Ref. No.	Description	R/S Part No.	Mfr's Part No.
VR501a,b	PERFECT LEVEL (250K/Bx2)	P-0790	28000133
VR551	Left VOLUME (250K/Bx2)	P-1632	28200025
VR552	Right VOLUME (250K/Bx2)	P-1632	28200025
VR601a,b	Bias Adjust (1K/B)	P-6274	28100037
VR602a,b	Meter Adjust (5K/B)	P-1165	28100034
VR901a,b	TREBLE (100K/Bx2)	P-4014	28000134
VR902a,b	BASS (100K/Bx2)	P-4014	28000134

## MISCELLANEOUS PARTS LIST

Ref. No.	Description	R/S Part No.	Mfr's Part No.
1	Wire Wrap Pin 13mm	HB-0955	19044001
2	Heat Sink B	HH-0200	15083001
3	Nut M3	HN-0081	41113070
4	Spring Washer M3	HW-0344	42250341
5	Screw M3x12		40330127
	Screw M3x8		40000086
7	Wire Connect Pin	HB-5542	19072001
8	Wire Wrap Pin 19mm	HB-0945	19043001
	Glass Cloth Tube 1φx6mm		31600206
10	Rear Panel	Z-3296	11197001
11	Fuseholder FH002	F-1017	34032001
12	AC Outlet IR02	J-6438	34048001
13	10P Screw Terminal	J-4430	53100240
14	Cord Strain Relief 4P4	HB-0954	74089001
15	AC Cord with Plug	J-4436	62110004
16	Ground Terminal X-P0701	HB-0953	53012300
	Flat Washer M3x10x0.8	HW-0804	42100008
18	Ground Lug M3		51036001
19	Screw M3x8 C		40000120
20	Fuse ST-2 4A, 125V		38334140
21	Binding Head Tapping Screw M3x8(B)	HS-0993	40630085
22	16P Phono Jack	J-0037	33160300
23	Front Chassis		03069001
24(M1a,b)	Power Meter	M-0330	60500002
25	Light Reflector Case	Z-3295	08053001

Ref. No.	Description	R/S Part No.	Mfr's Part No.
26	Meter Lamp Filter	HB-5538	74126001
27	Headphone Jack	J-0739	33030400
28(SW13)	Power Switch TV-5	S-7296	27200082
29	Screw M3x6	HS-0458	40330061
30	Tapping Screw M3x6	HS-1001	40130061
31	Rubber for Meter	HB-5537	74130001
32	Metal Spacer for Power Switch	HB-5540	55045001
	Light Shield Fiber	HB-5539	73225001
34	Plastic Rivet		84254001
35	Main Chassis		01091001
36(T851)	Power Transformer	TA-0596	35900226
	Terminal Strip 1P1L	J-4438	51025002
	Ground Lug		63319001
39	Metal Bracket for PCB	HB-5535	63352001
40	Plastic foot	F-0196	84260001
41	Tapping Screw M4x15	HS-1554	40140151
42	Nut M5		41115010
43	Flat Washer M5		42120521
44	Spring Washer M5		42250541
45	Screw M5x15	HS-2277	40350151
	Screw M3x8		40330081
	Screw M3x6 (B)		40000085
48	Static Shield Plate	RT-0853	09069001
	Screw M3x12	HS-2381	40000032
50	Binding Head Screw M3x6 C		40000082
51	Heat Sink	HH-0199	15081001
52	Heat Sink Plate	RT-0852	15080001
53(SW14)	Thermal Protector 90C	HB-4796	30700180
54	Metal Bracket for Thermal Protector	HB-5534	63359001
55	Front Panel Assembly	Z-3294	10198001
56	Knob for Right VOLUME	K-2394	29241003
57	Knob for Left VOLUME	K-2393	29242003
58	Push Switch Knob	K-2391	29244001
59	Power Switch Knob	K-2390	29245001
60	Knob for BASS, TREBLE & SELECTOR	K-1618	29150002
61	Knob for PERFECT LEVEL	K-2392	29243001
62	Knob for Flip Lever Switch	K-2389	29246001
63	Wooden Cabinet	Z-3293	85072001
64	Plastic Washer	HW-0809	84092001
65	Tapping Screw M4x15 (B)	HS-2278	40640155
66	Pin Connector		36012001
67	Insulation Fiber		75080001
(TH601a,b)	Thermister TD5-A120		30700090

RADIO SHACK  A DIVISION OF TANDY CORPORATION

U.S.A.: FORT WORTH, TEXAS 76102

CANADA: BARRIE, ONTARIO, CANADA L4M 4W5

---

TANDY CORPORATION

AUSTRALIA

280-316 VICTORIA ROAD  
RYDALMERE, N.S.W. 2116

BELGIUM

PARC INDUSTRIEL DE NANINNE  
5140 NANINNE

U. K.

BILSTON ROAD  
WEDNESBURY, STAFFS WS10 7JN



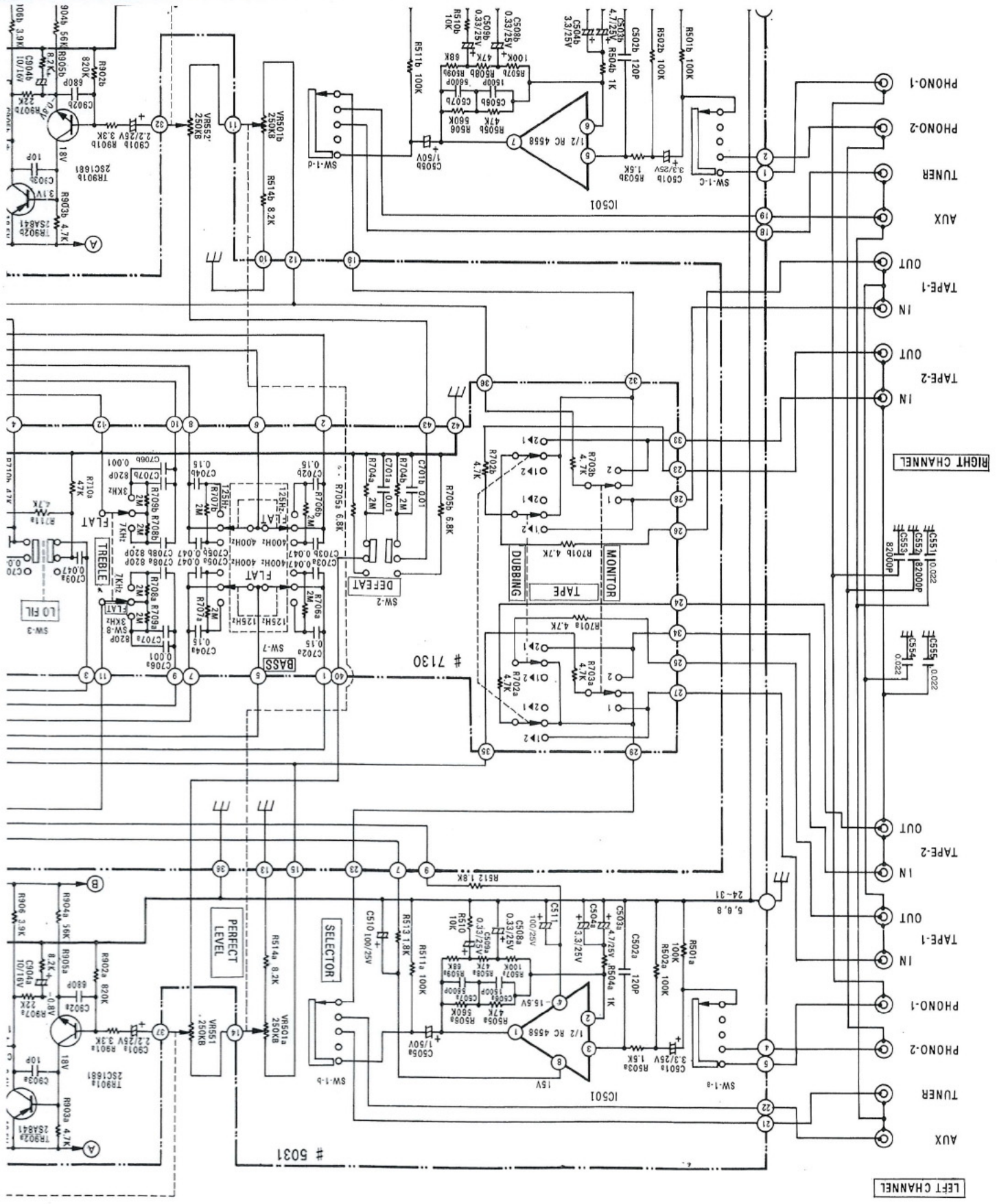

S

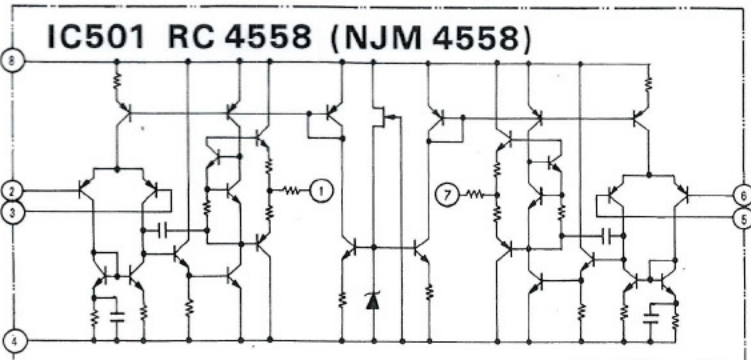
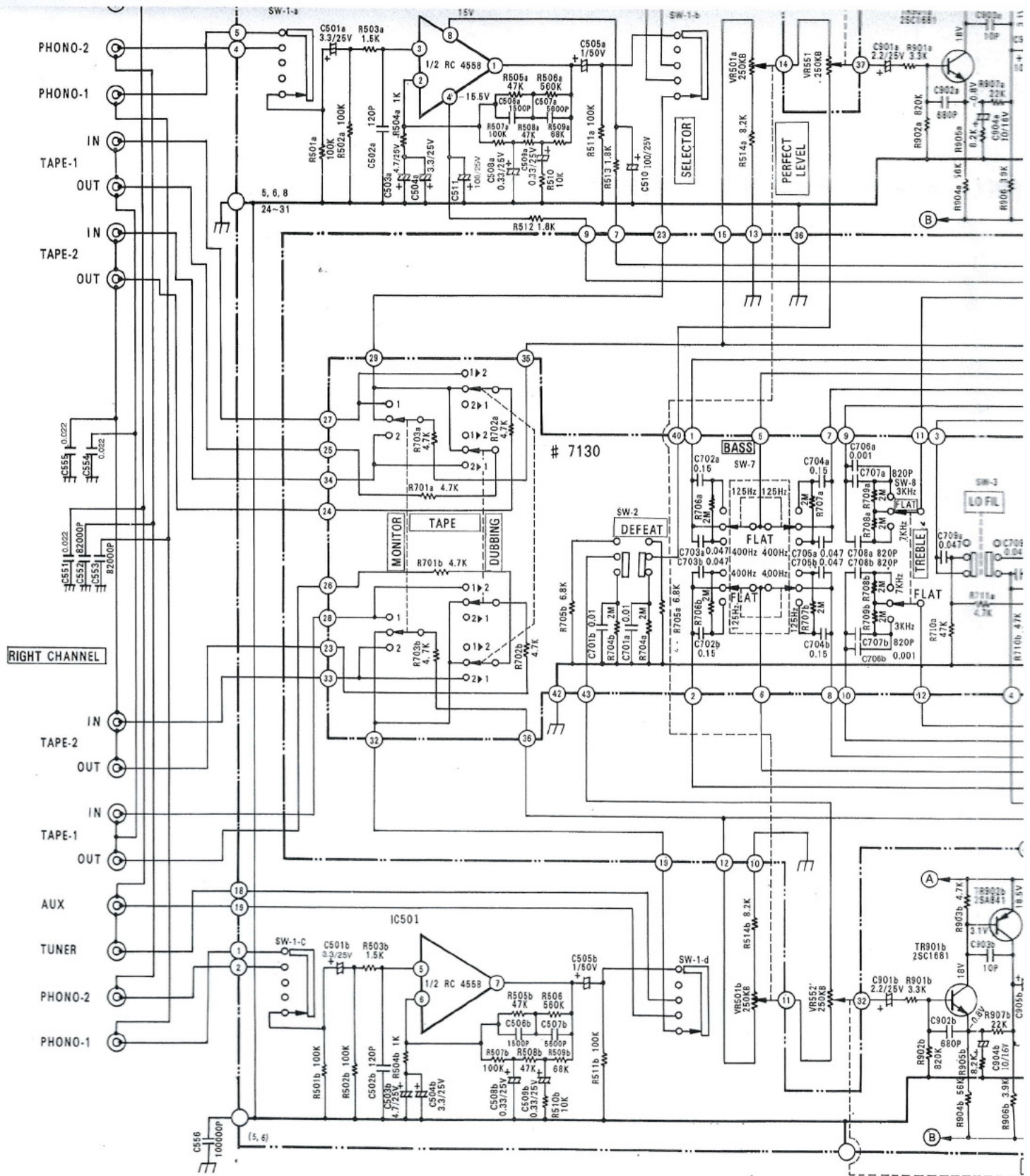

- Note : 1. Resistance values are indicated in unless otherwise specified (K = 1000, M = 1000000)
2. Capacitance values are shown in unless otherwise noted (P = micro)
3. DC voltages are referenced to ground conditions. No signal.
4. Switch is shown in PHONO position

# CHEMATIC DIAGRAM

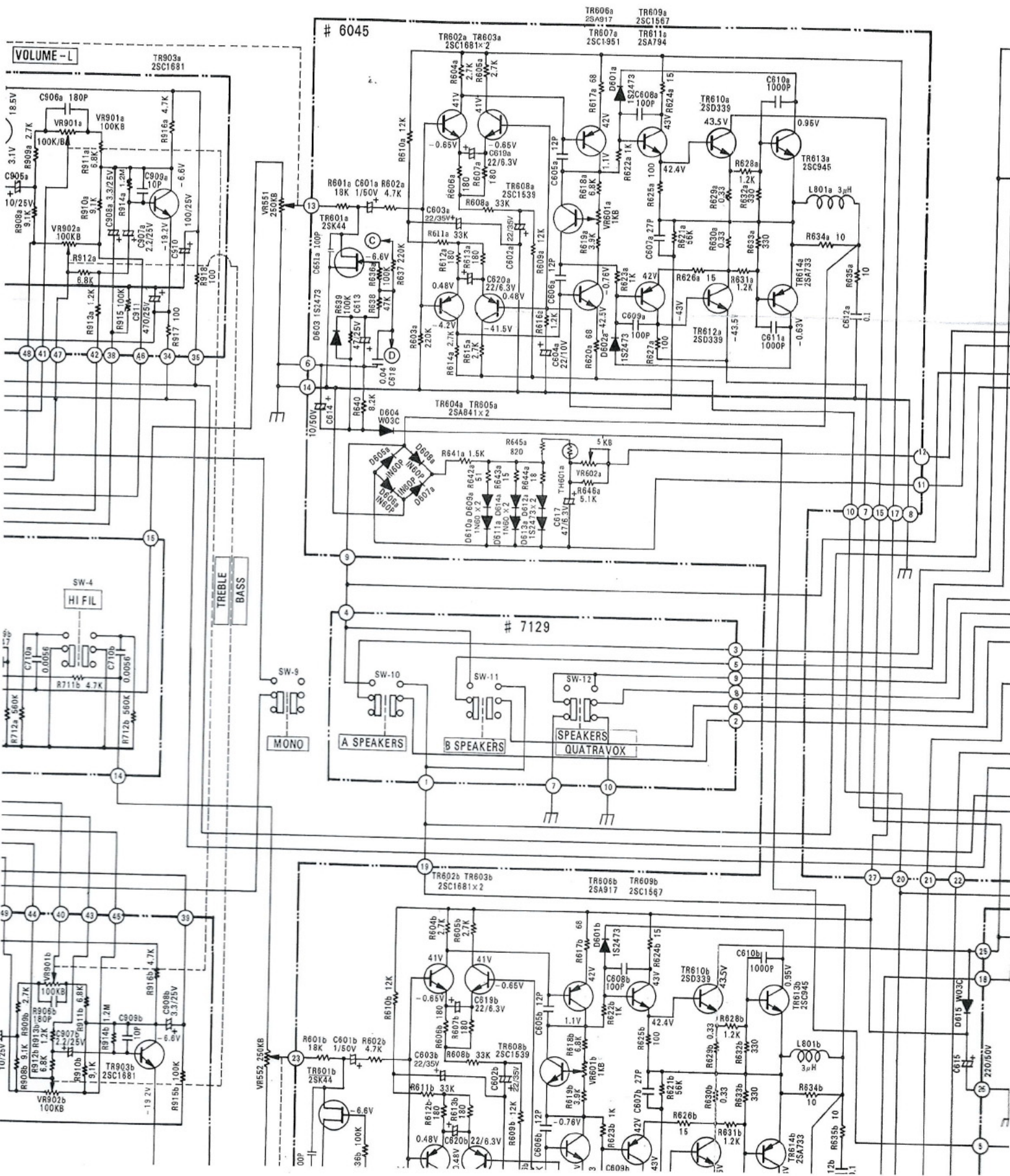

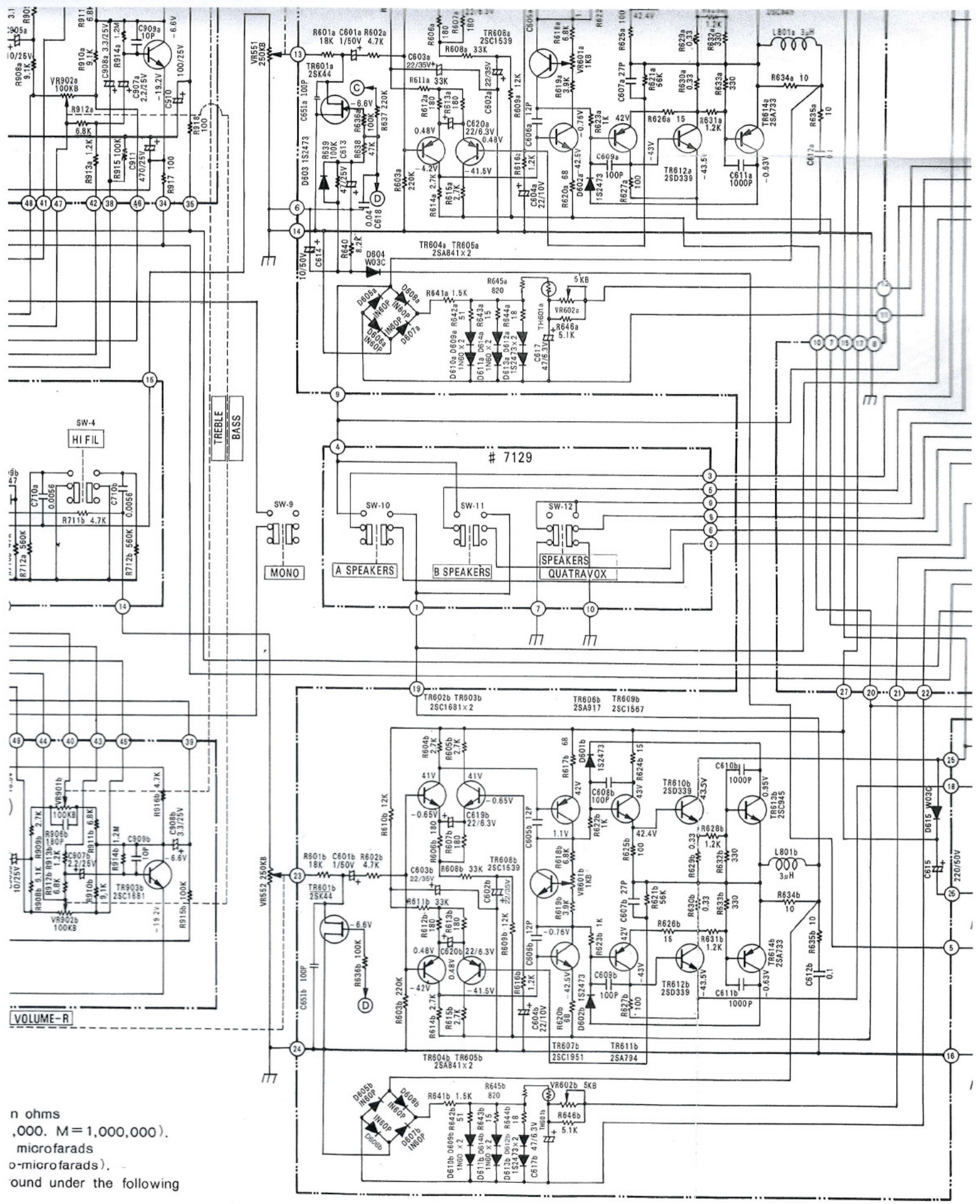

n ohms  
 ,000. M = 1,000,000).  
 microfarads  
 o-microfarads).  
 ound under the following

tion.



