

**REALISTIC<sup>®</sup>**

# Service Manual

31-2077

## STA-78 AM/FM STEREO RECEIVER Catalog Number : 31-2077

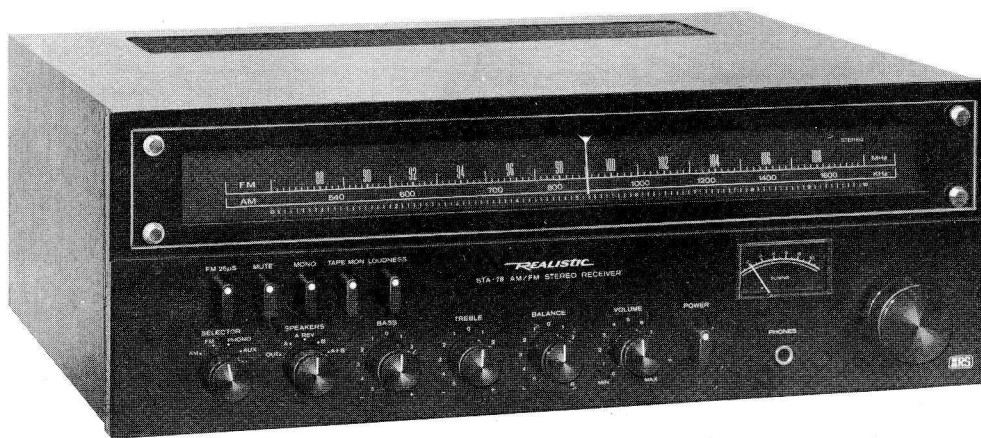

CUSTOM MANUFACTURED FOR RADIO SHACK  A DIVISION OF TANDY CORPORATION

# CONTENTS

	PAGE
(1) ELECTRICAL PERFORMANCE SPECIFICATIONS .....	3 - 5
(2) DISASSEMBLY INSTRUCTIONS .....	5
(3) BLOCK DIAGRAM .....	6
(4) DIAL STRINGING DIAGRAM .....	7
(5) LEVEL DIAGRAM .....	7
(6) ALIGNMENT INSTRUCTIONS .....	8 - 12
(7) TROUBLESHOOTING .....	13 - 16
(8) BRIEF DESCRIPTION OF PROTECTOR CIRCUIT .....	16
(9) IC & TRANSISTOR LEAD IDENTIFICATIONS .....	17
(10) AM/FM TUNER, IF & MPX P.C.B. (TOP & BOTTOM VIEWS) .....	18
(11) PHONO EQUALIZER AMP P.C.B. (TOP & BOTTOM VIEWS) .....	19
(12) TONE CONTROL P.C.B. (TOP & BOTTOM VIEWS) .....	20
(13) MAIN AMP P.C.B. (TOP & BOTTOM VIEWS) .....	21
(14) SWITCH P.C.B. (TOP & BOTTOM VIEWS) .....	22
(15) NOISE MUTING P.C.B. (TOP & BOTTOM VIEWS) .....	23
(16) POWER SUPPLY P.C.B. (TOP & BOTTOM VIEWS) .....	23
(17) ELECTRICAL PARTS LIST .....	24 - 31
(18) EXPLODED VIEW PARTS LIST .....	32 - 33
(19) IC INTERNAL DIAGRAM .....	33 - 35
(20) SCHEMATIC DIAGRAM .....	36 - 37
(21) EXPLODED VIEW .....	38 - 39

# 1. ELECTRICAL PERFORMANCE SPECIFICATIONS

## AM BAND

	UNIT	NOMINAL	LIMIT	
Frequency Coverage	kHz	510-1650	520-1620	
IF	kHz	455	-	
Usable Sensitivity for S/N 20 dB at	600 kHz	$\mu\text{V}/\text{m}$	200	500
	at 1000 kHz	$\mu\text{V}/\text{m}$	200	500
	at 1400 kHz	$\mu\text{V}/\text{m}$	200	500
S/N Ratio at 5 mV/m input 1000 kHz	dB	45	40	
Selectivity at 1000 kHz $\pm$ 10 kHz input = S/N 6 dB Sens. input	dB	32	25	
AGC Distortion at 1000 kHz, 80% mod. 100 mV/m input	%	4	8	
AGC Figure of Merit	dB	50	42	
IF Rejection Ratio at 600 kHz	dB	35	28	
Image Rejection Ratio at 1400 kHz	dB	45	38	
Bandwidth at 6 dB down	kHz	6	4.5-9	
Distortion at 5 mV/m input, 30% mod.	%	0.8	2	
Tape out Level at 5 mV/m input (RCA)	mV	200	$200 \pm 2.5$ dB	
Tape out Level at 5 mV/m input (DIN)	mV	15	$15 \pm 2.5$ dB	
Fidelity Bandwidth at 5 mV/m input (1 kHz = 0 dB)	Hz	50-2200	80-1800	
Whistle Modulation of 2nd and 3rd harmonic, at 1 mV/m, 5 mV/m and 100 mV/m input	%	3	8	
Dial Calibration at 600 kHz	kHz	0	$\pm 25$	
at 1400 kHz	kHz	0	$\pm 50$	
Overload: With a radiated signal of 1 V/m, the signal shall be tunable without undue distortion or breakup.				

## FM BAND

	UNIT	NOMINAL	LIMIT	
Frequency Coverage	MHz	86.5-109	88-108	
IF	MHz	10.7	-	
IHF Sensitivity at	90 MHz	$\mu\text{V}$	1.9	3.8
	at 98 MHz	$\mu\text{V}$	1.9	3.8
	at 106 MHz	$\mu\text{V}$	1.9	3.8
New IHF	dBf	10.8	16.8	
S/N 50 dB Quieting Sensitivity at 90, 98 and 106 MHz	$\mu\text{V}$	2.8	4.5	
	dBf	14.2	18.2	
S/N Ratio at 1 mV input	dB	65	55	
3 dB Limiting Sensitivity	$\mu\text{V}$	1.8	3.5	
IF Rejection Ratio at 90 MHz	dB	85	70	
Image Rejection Ratio at 106 MHz	dB	58	48	
Spurious Response and Cross Modulation	dB	80	65	
Capture Ratio	dB	1.5	4	
Alternate Channel Selectivity 100 $\mu\text{V}$ input	dB	60	48	
Distortion at 1 mV input	%	0.1	0.5	
Dial Calibration at 90 MHz	kHz	-	$\pm 250$	
AFC Holding Range at 1 mV input	kHz	$\pm 250$	$\pm 250 \pm 100$	
Temperature Range for Satisfactory operation	$^{\circ}\text{C}$	-	0-45	
AM Suppression	dB	50	42	
Maximum Signal Handling Capacity	mV	200	100	
Tape out Level at 1 mV input (RCA)	mV	750	$750 \pm 2.5$ dB	
Tape out Level at 1 mV input (DIN)	mV	15	$15 \pm 2.5$ dB	

	UNIT	NOMINAL	LIMIT
Muting Sensitivity	$\mu V$	5.5	3.5-9.0
Frequency Response (De-emphasis)			
75 $\mu S$ (UL & C.S.A.)	dB	-	+1 -3 dB
50 $\mu S$ (Australian)	dB	-	+1 -3 dB
25 $\mu S$ (for FM Dolby)	dB	-	+1 -3 dB

All sets must meet the requirements of the FCC, FTZ.

### FM STEREO BAND

	UNIT	NOMINAL	LIMIT
Stereo Indicator Sensitivity	$\mu V$	5.5	3.5-9.0
Stereo Separation at 1 mV input at 100 Hz	dB	38	28
at 1 kHz	dB	48	33
at 10 kHz	dB	35	28
Stereo Distortion at 1 mV, 1 kHz input	%	0.5	1.5
Pilot and Sub-carrier Leakage	dB	50	45

### AUDIO SECTION

	UNIT	NOMINAL	LIMIT
Input Impedance PHONO MAG.	K ohm	50	-
AUX	K ohm	50	-
TAPE IN	K ohm	50	-
Output Power, THD 0.5% from 20 Hz to 20 kHz, 8 ohms Both Channel Driven	W	25	22
Output Power, THD 0.5% at 1 kHz Both Channel Driven	W	27	24
Distortion at 5 W from 20 Hz to 20 kHz	%	0.15	0.3
Sensitivity for Rated Power (22 W)			
PHONO MAG.	mV	2.2	2.2 $\pm$ 3 dB
AUX	mV	160	160 $\pm$ 3 dB
TAPE IN	mV	160	160 $\pm$ 3 dB
Frequency Response at AUX from 20 Hz to 20 kHz input, 1 W output	dB	Flat	$\pm$ 2
Bass Action at 100 Hz	dB	$\pm$ 10	$\pm$ 10 $\pm$ 2.5
Treble Action at 10 kHz	dB	$\pm$ 10	$\pm$ 10 $\pm$ 2.5
Min. Volume Hum & Noise	mV	1	3
Signal to Noise Ratio PHONO MAG. (Input shorted)	dB	65	55
AUX (Input 10 K ohm terminated)	dB	75	65
TAPE IN (Input 10 K ohm terminated)	dB	75	65
Cross Talk at 1 kHz AUX Position	dB	55	45
Loudness contour ch. at 100 Hz -30 dB Vol. position	dB	+9	+9 $\pm$ 2.5
Loudness contour ch. at 10 kHz -30 dB Vol. position	dB	+4	+4 $\pm$ 2.5
Channel Balance at AUX, Vol. = Max.	dB	-	$\pm$ 2
TAPE OUT Level PHONO MAG. (RCA)	mV	150	150 $\pm$ 3 dB
AUX. (RCA)	mV	150	150 $\pm$ 3 dB
PHONO MAG. Equalizer Response at 100 Hz	dB	+13.11	$\pm$ 2 dB
at 10 kHz	dB	-13.75	$\pm$ 2 dB
PHONO MAG. Over Load (THD = 0.5%)	mV	120	90
DC Balance	mV	0	$\pm$ 30

**Note:**

The supply voltage is 120 volts AC (for UL & C.S.A.) and 240 volts AC for Australian models, from a regulated power supply.

The power source must be insulated from other equipment connected antenna or output. The room temperature is 25 degrees C.

Nominal Specs represent the design specs; all units should be able to approximate these — some will exceed and some may drop slightly below these specs.

Limit Specs represent the absolute worst condition which still might be considered acceptable; in no case should a unit perform to less than within any Limit Spec.

## 2. DISASSEMBLY INSTRUCTIONS

**1) To remove Chassis from wooden cabinet.**

Turn the cabinet upside down and remove the six screws from the bottom cabinet. (Figure A)

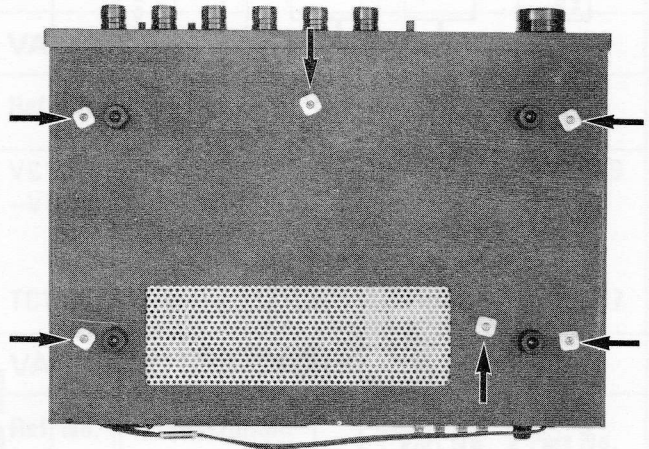

Figure A

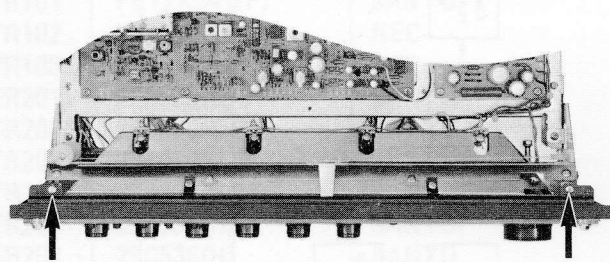

Figure B1

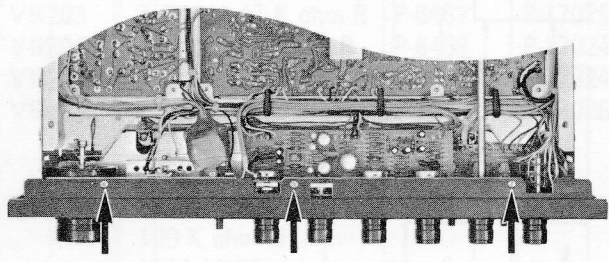

Figure B2

**2) Removal of Front Panel.**

- a) Remove the chassis from wooden cabinet as described in 1).
- b) Pull out the Main Chassis.
- c) Remove the two screws from the top and three screws from the bottom of the Front Panel.
- d) Remove knobs and pull off panel. (Figure B1, B2)

**3) To remove Rear Panel from chassis.**

Remove the four screws from the Rear Panel. (Figure C)

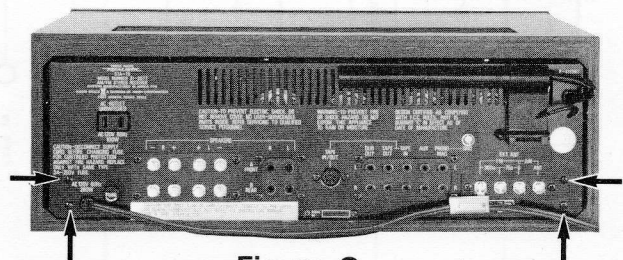
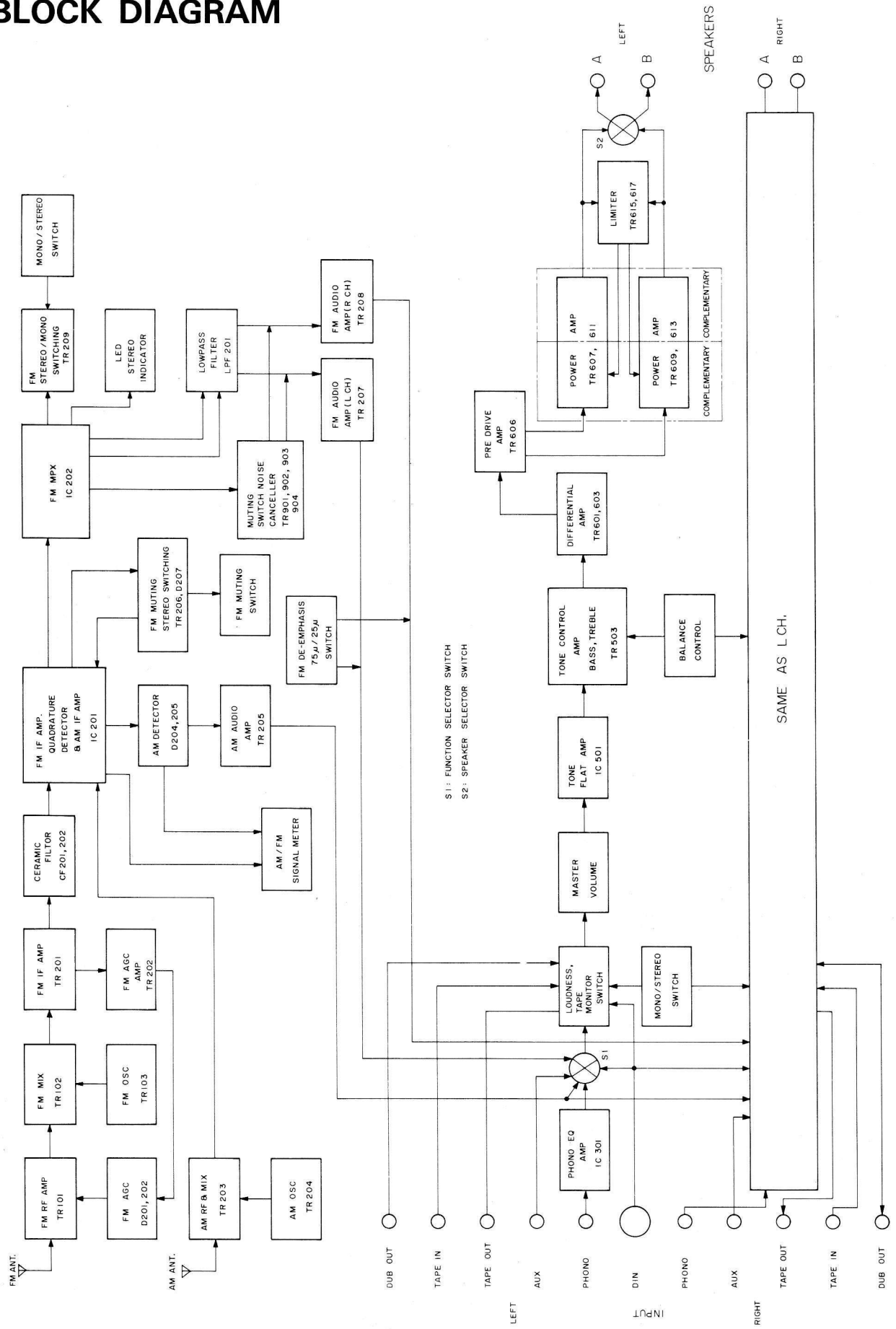
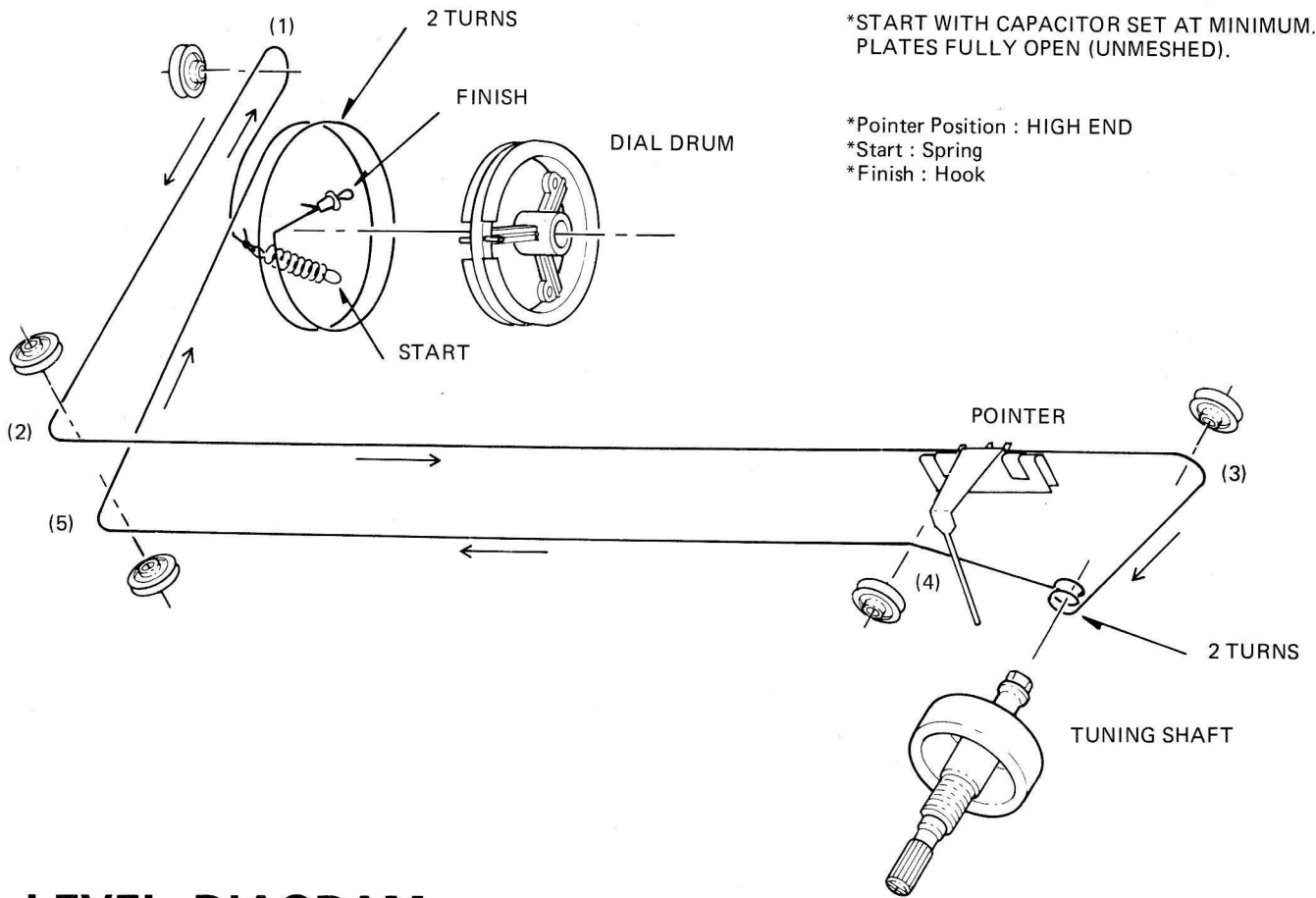

Figure C

# 3. BLOCK DIAGRAM



# 4. DIAL STRINGING DIAGRAM



\*START WITH CAPACITOR SET AT MINIMUM. PLATES FULLY OPEN (UNMESHD).

- \*Pointer Position : HIGH END
- \*Start : Spring
- \*Finish : Hook

# 5. LEVEL DIAGRAM

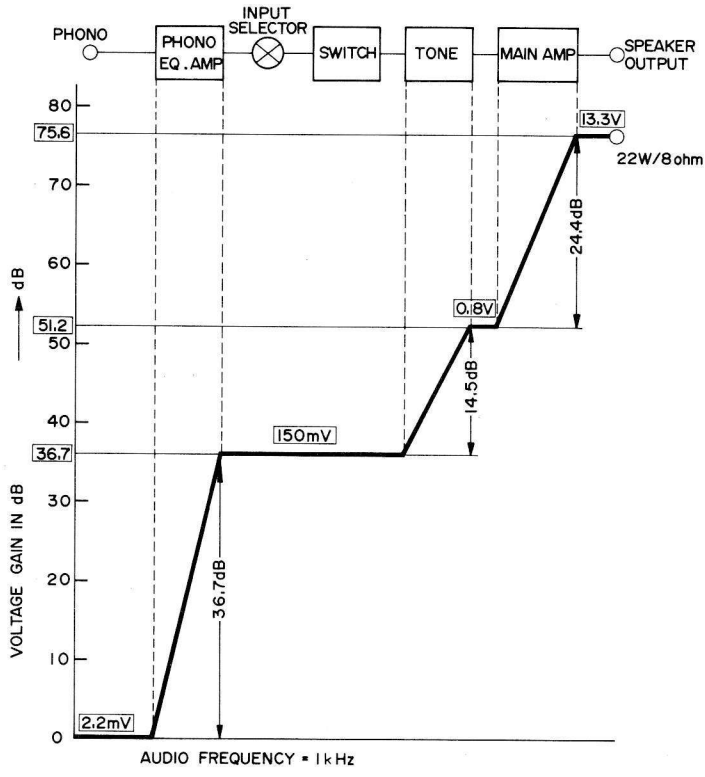

# 6. ALIGNMENT INSTRUCTIONS

## AUDIO CIRCUIT ADJUSTMENT / CHECK

### EQUIPMENT REQUIRED

1. DC Voltmeter
2. Audio Oscillator
3. Oscilloscope
4. AC Voltmeter

Note: \*Maintain voltage at 120 volts AC, 60 Hz (UL, CSA)  
(240 volts, 50 Hz AC for Australian models).

\*Set SELECTOR Switch to AUX.

\*Set MODE Switch to STEREO.

\*See P.C.B. illustration for alignment points/adjustments.

For location of connection points and trimmer resistors, see P.C.B. view.

### MAIN AMP ADJUSTMENT

STEP	ADJUSTMENT	EQUIPMENT	CONNECTION	AUDIO FREQ.	LEVEL	ADJUSTMENT
1	Check Balance by measuring DC voltage across Output Terminal of L and R channel.	DC Volt Meter	See Figure 1.	No signal	DC voltage should be less than 25mV.	
2	Idling current adjustment	DC Volt Meter	See Figure 2.	No signal	Adjust so voltage across Emitter resistors R633 and R634 is 5 mV (8 ohm load).	VR601 VR602

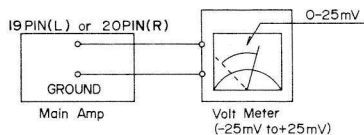

Figure 1

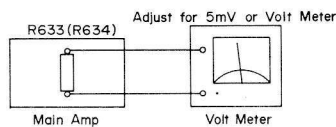

Figure 2

### CHECKING LIMITER CIRCUIT

STEP	ADJUSTMENT	EQUIPMENT	CONNECTION	AUDIO FREQ.	SETTING	LEVEL
1		Audio Osc. V.T.V.M. Oscilloscope	See Figure 3.	1000 Hz	VOLUME: Max. BASS, TREBLE BALANCE: center	Adjust input to AUX to get output level at just the clipping point (4 ohm load) Figure 4.
2	Check the limiter circuit.	Audio Osc. V.T.V.M. Oscilloscope	See Figures 3, 5.	1000 Hz	Same as above	Check that output dropt to a square wave across R633 (R634) when output speaker terminals are shorted. See Figure 6.

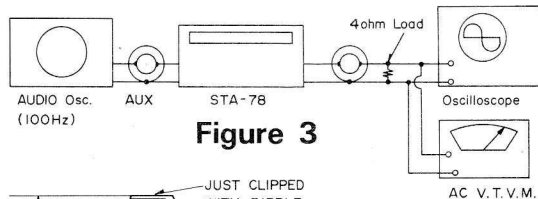

Figure 3

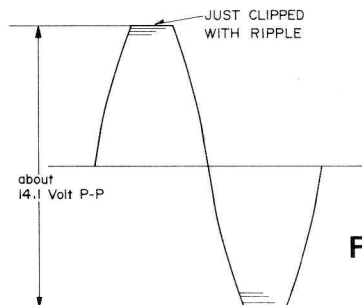

Figure 4

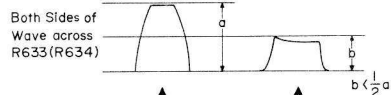

Figure 6

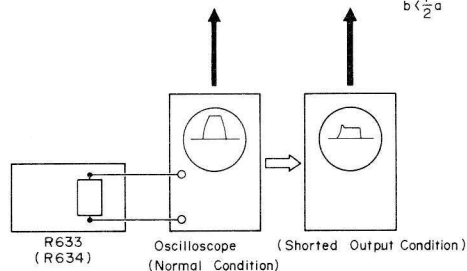

Figure 5



# AM RF & IF ALIGNMENT

## EQUIPMENT REQUIRED

1. AM Signal Generator
2. AC Voltmeter
3. Oscilloscope
4. Distortion Meter

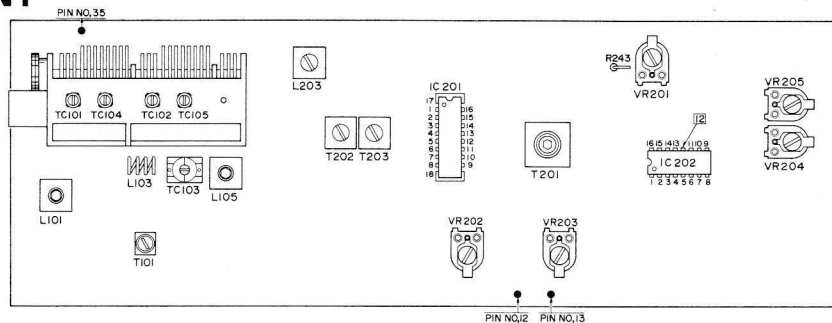

Figure 7

- Note:**
- \*Signal generator output should be no higher than necessary to obtain an output reading.
  - \*Maintain line voltage at 120 volts, 60 Hz AC (UL & CSA) (240 volts, 50 Hz AC for Australian models).
  - \*Set SELECTOR Switch to AM.
  - \*See P.C.B. illustrations for alignment points/adjustments and Figure 7.

STEP	SIGNAL GENERATOR COUPLING	SIGNAL GENERATOR FREQUENCY	DIAL SETTING	INDICATOR	ADJUSTMENT	REMARKS
1	Connect standard loop ANTENNA to Signal Generator and radiate signal into the AM Ferrite Antenna. See Figure 8.	455 kHz (400 Hz, 30% mod.)	Point of non-interference (near 600 kHz)	Scope and AC Voltmeter to TAPE OUT Jack.	T202 T203 (AM IFT)	Adjust for maximum reading on meter.
2	Same as STEP 1.	510 kHz (400 Hz, 30% mod.)	Tuning Gang fully closed.	Same as STEP 1.	L203 (AM OSC Coil)	Adjust for maximum reading on meter. Refer to Figures 7 and 8.
3	Same as STEP 1.	1650 kHz (400 Hz, 30% mod.)	Tuning Gang fully opened.	Same as STEP 1.	TC105 (AM OSC Trimmer)	Adjust for maximum reading on meter. Refer to Figures 7 and 8.
4	Same as STEP 1.	600 kHz (400 Hz, 30% mod.)	600 kHz	Same as STEP 1.	L802 (AM ANT. Coil)	Adjust for maximum reading on meter. Refer to Figures 7 and 8.
5	Same as STEP 1.	1400 kHz (400 Hz, 30% mod.)	1400 kHz	Same as STEP 1.	TC104 (AM ANT. Trimmer)	Adjust for maximum reading on meter. Refer to Figures 7 and 8.
6	Repeat STEPs 4 and 5 until no further change is noticed.					
7	Same as STEP 1.	1000 kHz (400 kHz, 30% mod.) Output level to 100 mV/m	1000 kHz	AM Signal Meter on Set.	VR201	Adjust so the Meter Pointer on Receiver is at about 85% of full scale.

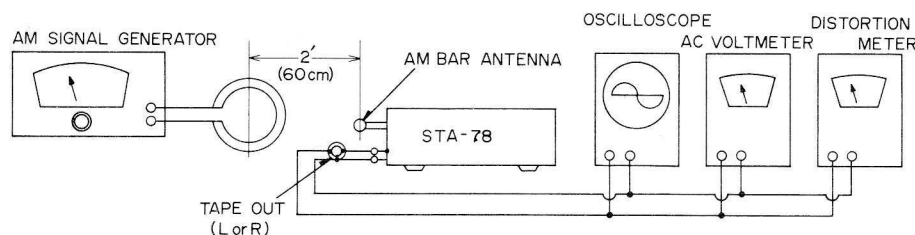

Figure 8

## FM RF & IF ALIGNMENT

### EQUIPMENT REQUIRED

1. FM Signal Generator
2. AC Voltmeter
3. Oscilloscope
4. Distortion Meter
5. Center Tuning Meter (1.2 K ohm, 200  $\mu$ A)

**Note:** \*Signal Generator output should be no higher than necessary to obtain an output reading.

\*Maintain line voltage at 120 volts, 60 Hz AC (UL & CSA) (240 volts, 50 Hz AC for Australian models).

\*Set SELECTOR Switch to FM.

\*Refer to P.C.B. illustration and Figure 7 for test points/adjustments.

STEP	GENERATOR COUPLING	GENERATOR FREQUENCY	DIAL SETTING	INDICATOR	ADJUSTMENT	REMARKS
1	Signal Generator to FM Antenna Terminal thru FM Dummy Antenna (300 ohm)	98 MHz (400 Hz, 75 kHz dev.) Input: about 2-3 $\mu$ V	Near 98 MHz	AC Voltmeter, Scope and Distortion meter to TAPE OUT Jack (L or R).	T101	Adjust for maximum reading on meter. Refer to Figure 11.
2	Same as STEP 1.	98 MHz (400 Hz, 75 kHz dev.) Input: no input (unit off)	Near 98 MHz	Connect the Center Tuning Meter (1.2 k $\Omega$ , 200 $\mu$ A) to Pin No. 12 (+) and No. 13 (-) on AM/FM IF Board (Refer to Figures 7 and 9A.)	T201 (Primary)	Adjust for Center point on Center Tuning Meter. Refer to Figures 9, 9A, 10 and 11.
3	Same as STEP 1.	98 MHz (400 Hz, 75 kHz dev.) Input: 1 mV	Same as STEP 1.	AC Voltmeter, Scope and Distortion Meter to TAPE OUT Jack (L or R).	T201 (Secondary)	Adjust for minimum Distortion (about 0.1%). Refer to Figure 9, 10 and 11.
4	Repeat STEPs 1, 2 and 3 until no further improvement is noticed.					
5	Same as STEP 1.	90 MHz (400 Hz, 75 kHz, dev.) Input: about 2-3 $\mu$ V	90 MHz	Same as STEP 1.	L101 (FM Antenna Coil) L103 (FM RF Coil - stretch or squeeze) L105 (FM OSC Coil)	Adjust for maximum reading on meter. Refer to Figures 7 and 11.
6	Same as STEP 1.	106 MHz (400 Hz, 75 kHz dev.) Input: about 2-3 $\mu$ V	106 MHz	Same as STEP 1.	TC 101 (FM Antenna Trimmer) TC102 (FM RF Trimmer) TC103 (FM OSC Trimmer)	Adjust for maximum reading on meter. Refer to Figures 7 and 11.
7	Repeat STEPs 5 and 6 until no further improvement is noticed.					
8	Same as STEP 1.	98 MHz (400 Hz, 75 kHz dev.) Input: 5 $\mu$ V	98 MHz	Same as STEP 1.	VR203	"MUTE" switched "ON" and adjust VR203 for no signal output.
9	Same as STEP 1.	98 MHz (400 Hz, 75 kHz dev.) Input: 100 mV	98 MHz	Signal Meter on Set.	VR202	Adjust so the Meter Pointer on Receiver is about 90% of full-scale.

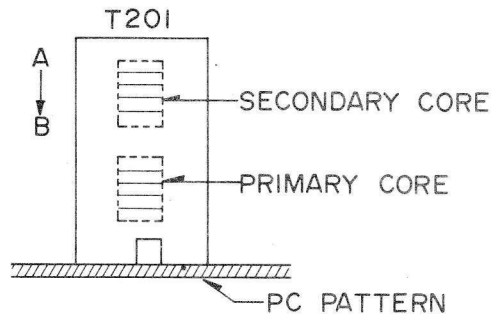

Figure 9

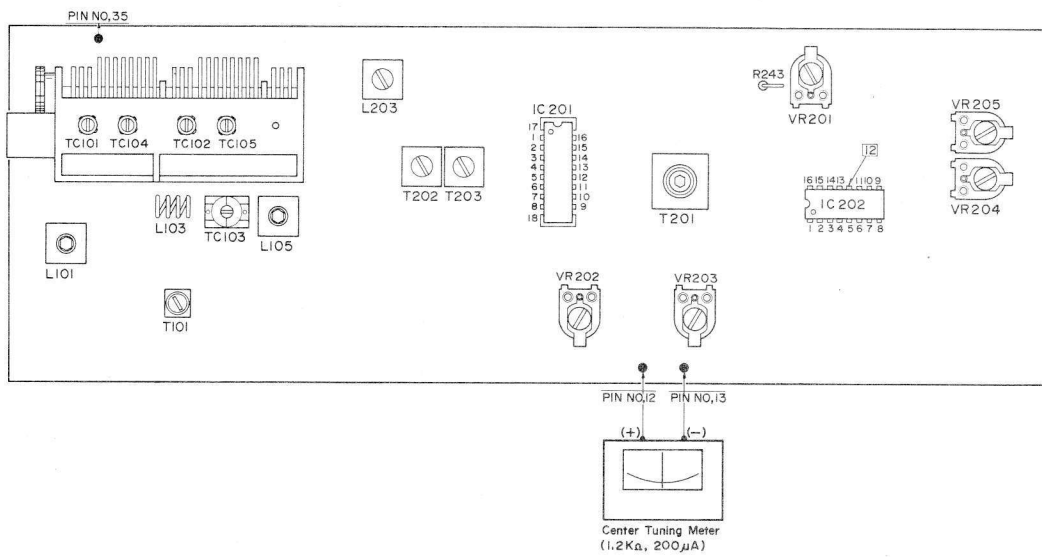

Figure 9A

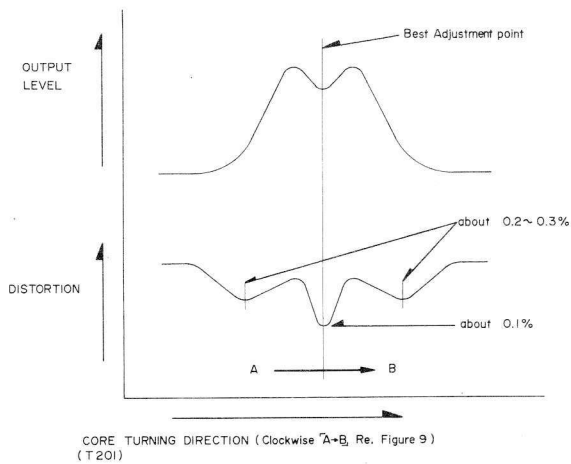

Figure 10

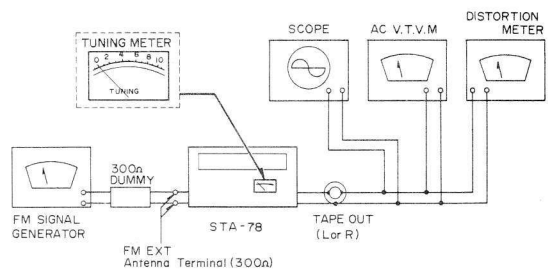

Figure 11

# FM STEREO ALIGNMENT

## EQUIPMENT REQUIRED

1. Stereo Modulation . . . Connect Stereo Modulator to EXT. Mod. terminal of FM Signal Generator. Modulation Level of 19 kHz Pilot Signal . . . 8–10%.
2. FM Signal Generator . . . Output Level – 1 mV  
Frequency – Approximately 98 MHz  
Deviation – 75 kHz, 100% modulation of composite signal
3. Audio Generator
4. AC Voltmeter
5. Oscilloscope
6. Distortion Meter
7. Frequency Counter

**Note:** See P.C.B. illustration for alignment/test points.  
Preliminaries  
Set SELECTOR Switch to FM STEREO and MUTE Switch to "OFF" position.

## MULTIPLEX & SEPARATION ALIGNMENT

STEP	SIGNAL GENERATOR COUPLING	STEREO MODULATION	INDICATOR	ADJUSTMENT	REMARKS
1	Connect to FM Antenna terminal thru FM dummy antenna (300 ohm).	Mono. 1 kHz (1000 Hz, No Mod.) Input: 1 mV	Counter connected to TP at Pin No. 12 of IC202.	VR205	Adjust for 19 kHz $\pm$ 50 Hz on Counter. Refer to Figure 12.
2	Same as above.	Composite MPX Signal 1 kHz on Left channel ONLY.	AC Voltmeter connector for TAPE OUT Jack of Right Channel.	VR204 (Separation)	Adjust for minimum reading on meter. Refer to Figure 13.
3	Same as above.	Composite MPX Signal 1 kHz on Right channel ONLY.	AC Voltmeter connector for TAPE OUT Jack of Left Channel.	Same as above.	Same as above.
4	Repeat STEPs 2 and 3 until AC Voltmeter reading is at least –40 dB same channel output. (ie. 40 dB separation).				
5	Same as STEP 1.	Composite MPX Signal 1 kHz.	AC Voltmeter connected to TAPE OUT Jack.		With 5.5 $\mu$ V antenna input signal, Stereo indicator lamp should come on.

## FM STEREO ALIGNMENT SET-UP

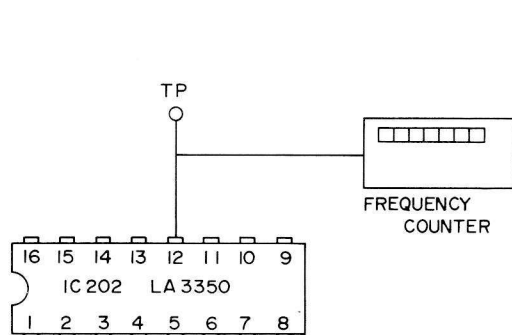

Figure 12

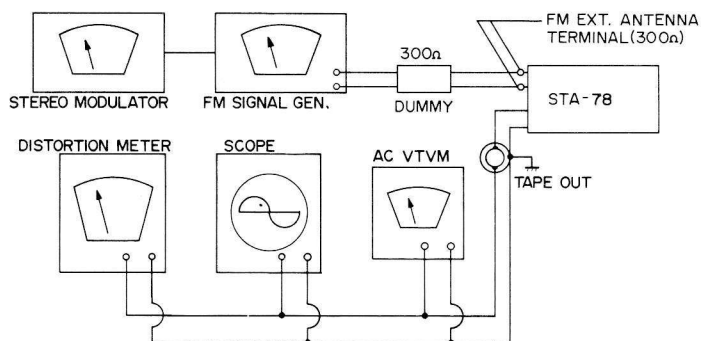

Figure 13

## 7. TROUBLESHOOTING

SYMPTOM	CAUSE / REMEDY
1) No output	1) Faulty AC power cord Replace the cord. 2) Defective POWER switch Replace the switch. 3) Broken wire in the Power Transformer Replace the Transformer. 4) Blown primary switch Replace the Fuse.
2) Pilot Lamp does not light.	1) Broken Lamp Replace the Lamp. 2) Open in the Power Transformer tertiary winding Replace the Transformer.
3) Pilot Lamp lights but no Speaker output.	1) Defective capacitor C802 or 803 Replace the defective capacitor(s). 2) Defective Rectifier D703 Replace the defective Rectifier. 3) Defect in the Power Transformer secondary winding Replace the Power Transformer.
4) Blows Fuse	1) Defective Rectifier D703 Replace the defective Rectifier. 2) Short-circuit in the rectifier circuit Remove the short. 3) Short-circuit in Power Transistor Circuitry TR611-614 Repair circuit and/or replace the defective Transistor(s).
5) "A" Speakers does not work.	1) Speaker Selector Switch defective Replace the switch. 2) Poor contact in Speaker Output Terminals Replace or repair it. 3) Poor contact in Speaker Selector Switch Repair or replace it.
6) "B" Speakers does not work.	1) Speaker Selector Switch defective Replace the switch. 2) Poor contact in Speaker Selector Switch Repair or replace it. 3) Poor contact in Speaker Output Terminals Repair or replace it.
7) No output one channel with VOLUME at maximum and BALANCE at center, when a test signal is applied to the terminal of non-operating channel of the BALANCE control VR502.	1) Defective Transistor TR501-503 or TR601-618 Replace the defective Transistor(s). 2) Defective resistor or capacitor of TONE and MAIN AMP circuit Replace the defective part(s).
8) No output when a test signal is applied to the input terminals, except PHONO input.	1) Defective MONO-Stereo or TAPE MONitor Switch Repair or replace the Switch. 2) Defective SELECTOR Switch Replace the Switch.
9) No output when a test signal is applied to the PHONO input terminals.	1) Defective transistor, resistor or capacitor of PRE EQ AMP circuit Replace the part(s). 2) Defective MONO-Stereo or TAPE switch Repair or replace the switch. 3) Defective SELECTOR Switch Replace the SELECTOR Switch.

SYMPTOM	CAUSE / REMEDY
10) Speaker works normally but Headphone does not work.	1) Defective R647 (Left) or R648 (Right) Change it. 2) Headphone plug does not mate with jack Replace the plug.
11) All the inputs work normally except "AUX" input.	1) Poor contact in "AUX" input jack Repair or replace it. 2) Poor contact in SELECTOR Switch Repair or replace the switch.
12) "PHONO" input inoperative	1) Poor contact in "PHONO" input jack Repair or replace it. 2) Faulty SELECTOR Switch Repair or replace it.
13) "TAPE OUT" inoperative	1) Poor contact in "TAPE OUT" output jack Repair or replace it.
14) "TAPE IN" inoperative	1) Poor contact in "TAPE IN" input jack Repair or replace the jack.
15) "DUB OUT" inoperative	1) Poor contact "DUB OUT" jack Repair or replace the jack.
16) No AM or FM (Tuner +B voltage is not 11-12 V.)	1) Broken tertiary winding in the Power Transformer Replace the Transformer. 2) Defective Diode D701 Change the defective diode. 3) Faulty capacitor C707, 711 or 713 Replace the defective capacitor(s). 4) Faulty resistor R705 or 707 Replace the resistor(s). 5) Zener Diode D704 defective Replace the Diode. 6) Short-circuit in Tuner +B circuit Repair the short. 7) Poor contact in SELECTOR Switch Repair or replace the Switch.
17) No FM	1) Poor contact in SELECTOR Switch Repair or replace it. 2) IC, Transistor, diode, resistor, capacitor, inductor or IFT of FM IF Board defective Replace the defective part(s). 3) FM Front End defective Replace the defective part(s). 4) Faulty FM Antenna lead-in/circuitry Repair or replace the Antenna lead-in/circuitry.
18) No AM	1) Poor contact in SELECTOR Switch Repair or replace Switch. 2) IC, Transistor, diode, resistor, capacitor or IFT of AM IF Board defective Replace the defective part(s). 3) Bar-Antenna Coil defective Repair or replace it.

SYMPTOM	CAUSE / REMEDY
19) No FM MPX Separation	1) Improper adjustment Readjust VR204 and 205. 2) IC202 of MPX board defective Replace the IC. 3) VR204, 205 defective Replace the Trimmer Resistor(s). 4) Defective Transistor TR207, 208 or 209 Replace the defective Transistor(s).
20) No STEREO light or FM Stereo does not work.	1) Broken STEREO Indicator Lamp Replace the lamp. 2) Defective IC202 of FM MPX Board Change the defective IC. 3) Defective Transistor TR207, 208 or 209 Replace the defective transistor(s). 4) VR204, 205 defective Replace the defective Trimmer Resistor(s).
21) "LOUDNESS" has no effect.	1) Defective "LOUDNESS" switch Replace the switch. 2) Defective C501, 502 or R501, 502 Replace the defective part(s).
22) "Stereo-MONO" not effective	1) Defective Stereo-MONO Switch Repair or replace the switch.
23) "MUTING" not effective	1) Defective MUTE Switch Repair or replace the switch. 2) Defective Transistor TR206 Replace the defective Transistor. 3) Defective Trimmer resistor VR203 Replace the Trimmer resistor. 4) Defective Diode D207 Replace the Diode. 5) Defective IC201 Replace the IC.
24) "FM 25 $\mu$ S" not effective	1) Defective FM 25 $\mu$ S switch Replace the switch. 2) Defective C403 or 404 Replace the defective part(s).
25) "TAPE MONITOR" does not operate.	1) Defective TAPE MONITOR switch Replace or repair the switch.
26) "BASS" has no effect.	1) Faulty VR504 (100 K ohm control) Replace it. 2) Defective C517-520 or R523-528 of TONE CONTROL Board Replace the defective part(s).
27) "TREBLE" has no effect	1) Faulty VR503 (100 K ohm control) Replace it. 2) Defective C513-516 or R517-522 of TONE CONTROL Board Replace the defective part(s).
28) "AM/FM SIGNAL METER" not functioning	1) Defective AM/FM Signal Meter Replace it.

SYMPTOM	CAUSE / REMEDY
	2) In case of FM reception, VR202, D206, C243, C244 or R240 defective Replace the defective part(s). 3) In case of AM reception, VR201, D204, R242 or C237-239 defective Replace the defective part(s). 4) Defective IC201 Replace the IC.

## 8. BRIEF DESCRIPTION OF PROTECTOR CIRCUIT

### (1) Limiting Circuit

If speaker terminals are shorted, the output line (©line of Figure 14) is grounded and excessively high current flows from collector to emitter of TR611 (TR612) and TR613 (TR614), and a high voltage will appear across R633 (R634) and R635 (R636).

This high voltage goes to base of TR615 (TR616) and TR617 (TR618).

When the voltage between base and emitter increases to about 0.6 V, TR615 (TR616) and TR617 (TR618) will be turned on.

High current (input signal of TR607 [TR608] and TR609 [TR610]) flows from collector to emitter of TR615 (TR616) and TR617 (TR618) through D611 (D612) and D613 (D614), and collector to emitter current of TR611 (TR612) and TR613 (TR614) will drop as Figure 14 (from @ to @', from ① to ②) because of the output current limiting, and thus protect Power Transistors TR611 (TR612) and TR613 (TR614).

If this should occur, turn off the Receiver.

When the problem is corrected, turn the Receiver on again.

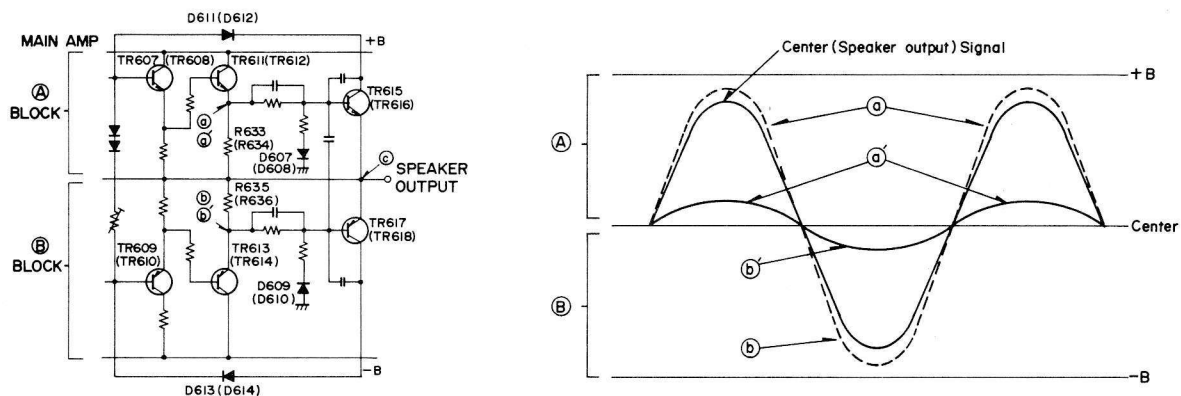

Figure 14

### (2) Abnormal Temperature Rise Protection

If the temperature of the MAIN Amp Heat Sink rises to 90°C, the Thermal Protector Switch will activate to shut down A.C. Power to the entire Receiver and thus protect the MAIN Amp. If this should occur, turn the Receiver "OFF".

When the temperature of the MAIN Amp Heat Sink falls to within the operating limits of the Receiver, the Thermal Protector Switch will reset itself.

When the problem is corrected, turn the Receiver on again.



# 8. IC & TRANSISTOR LEAD IDENTIFICATIONS



2SK41

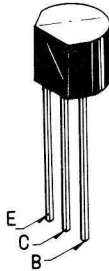

2SC1175  
2SA659  
2SC536  
2SC930  
2SC929  
2SC1570

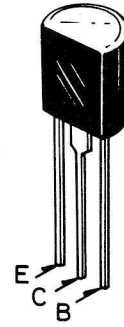

2SD438  
2SB560

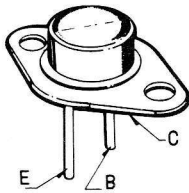

2SB509  
2SD315



2SC1674  
2SC900  
2SC923  
2SC945A



2SD571

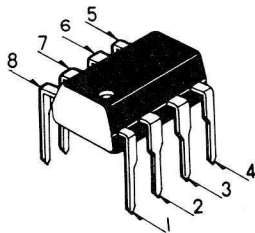

NJM-4558

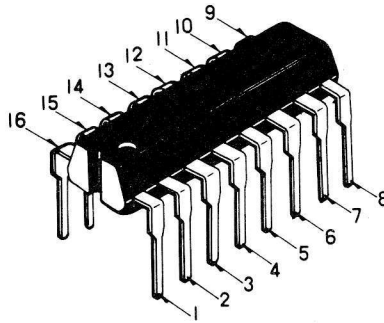

LA-3350

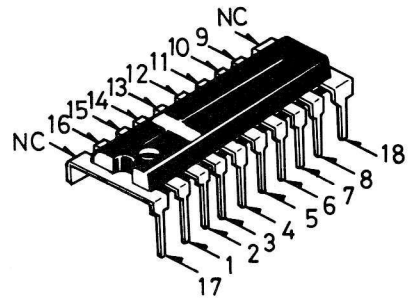

HA-11211

# 10. AM/FM TUNER, IF & MPX P.C.B. (TOP & BOTTOM VIEWS)

TOP VIEW

BOTTOM VIEW

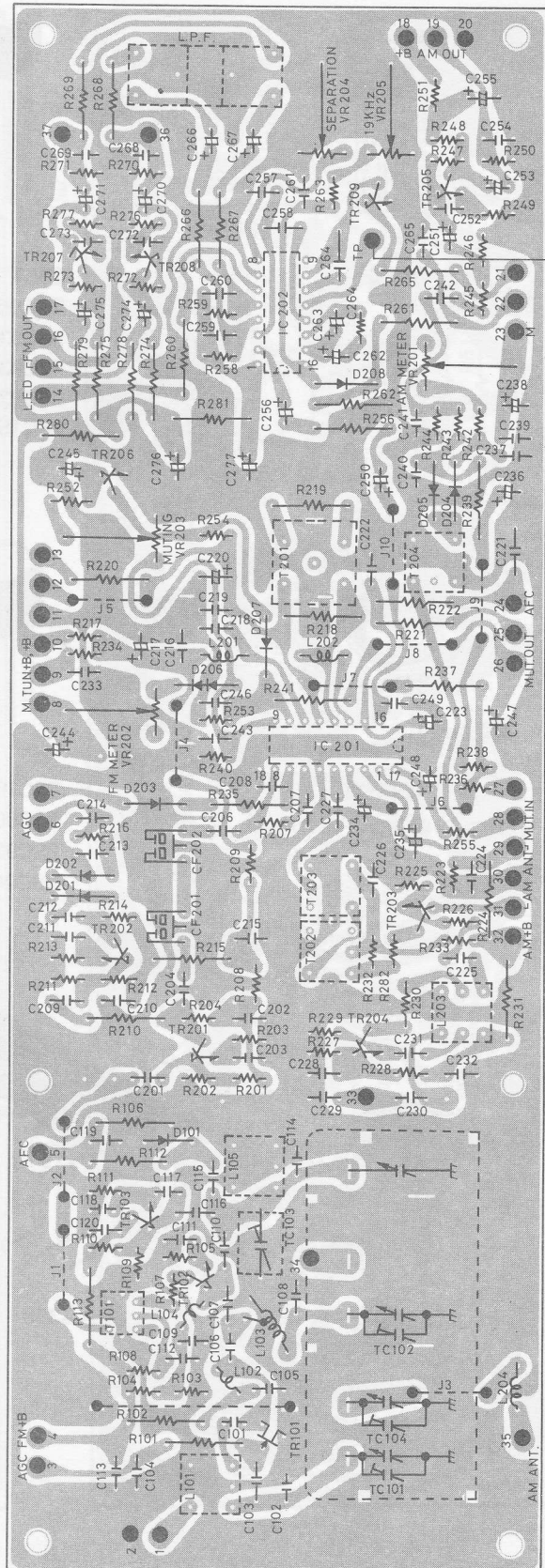
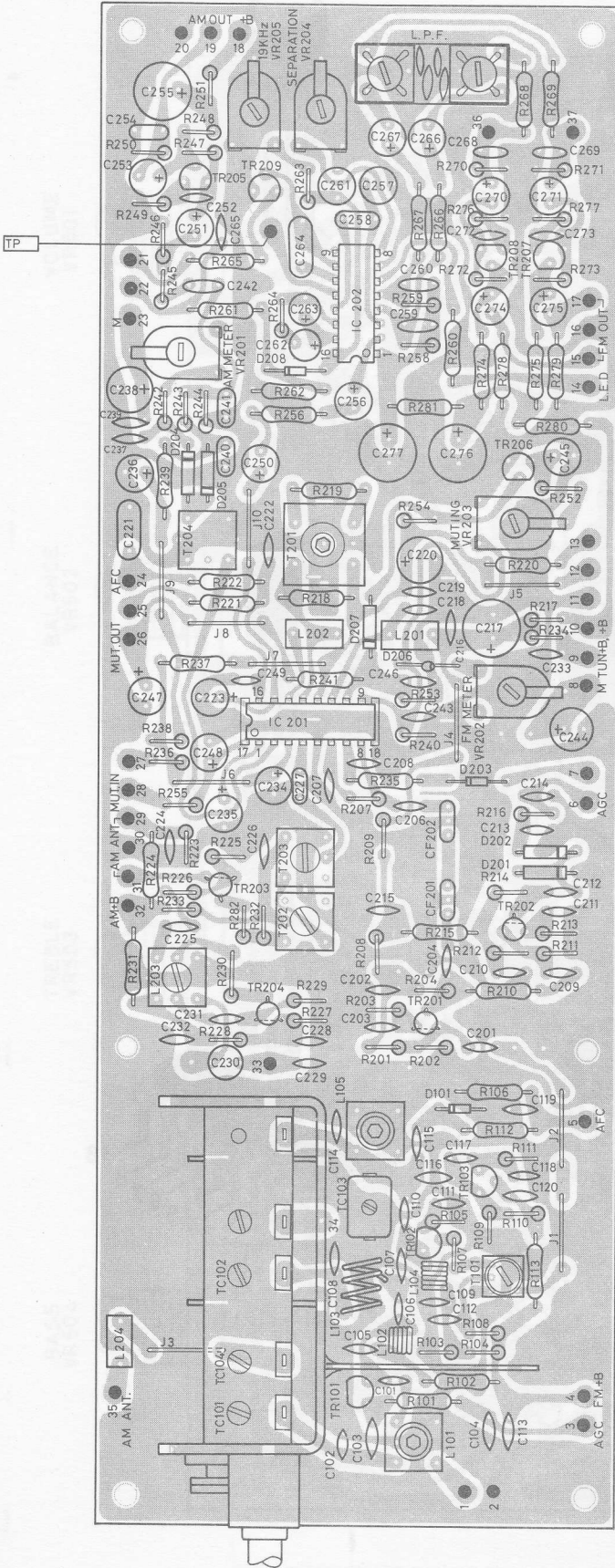

# 11. PHONO EQUALIZER AMP P.C.B. (TOP & BOTTOM VIEWS)

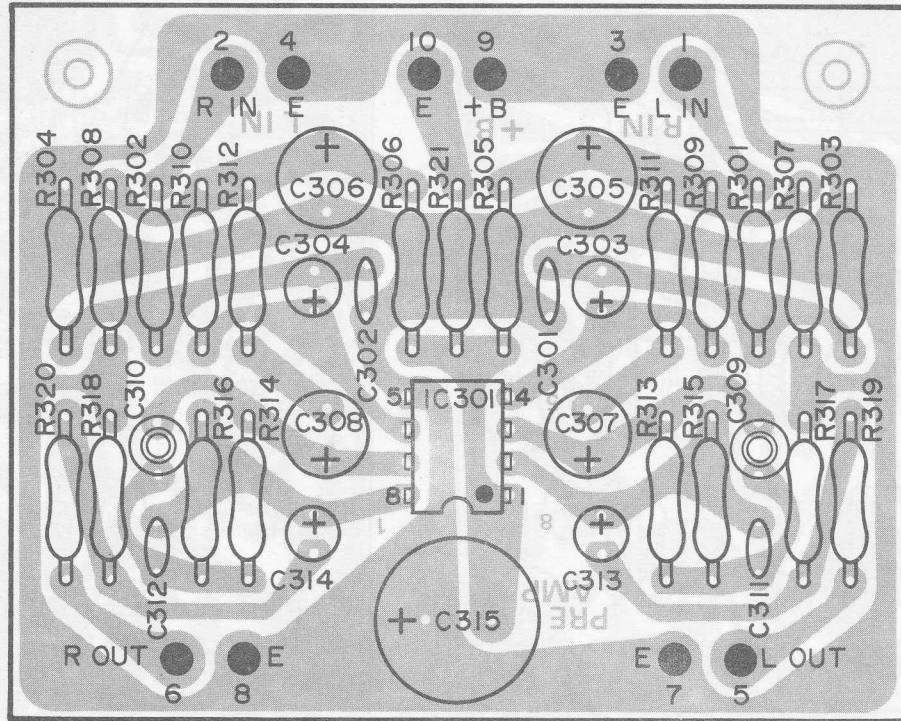

BOTTOM VIEW

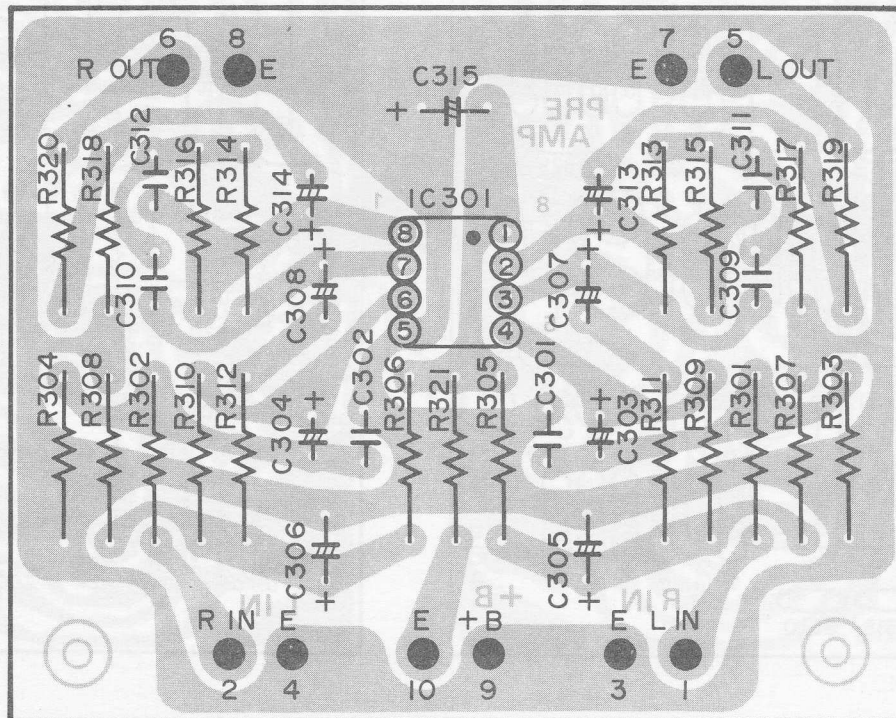

# 12. TONE CONTROL P.C.B. (TOP & BOTTOM VIEWS)

TOP VIEW

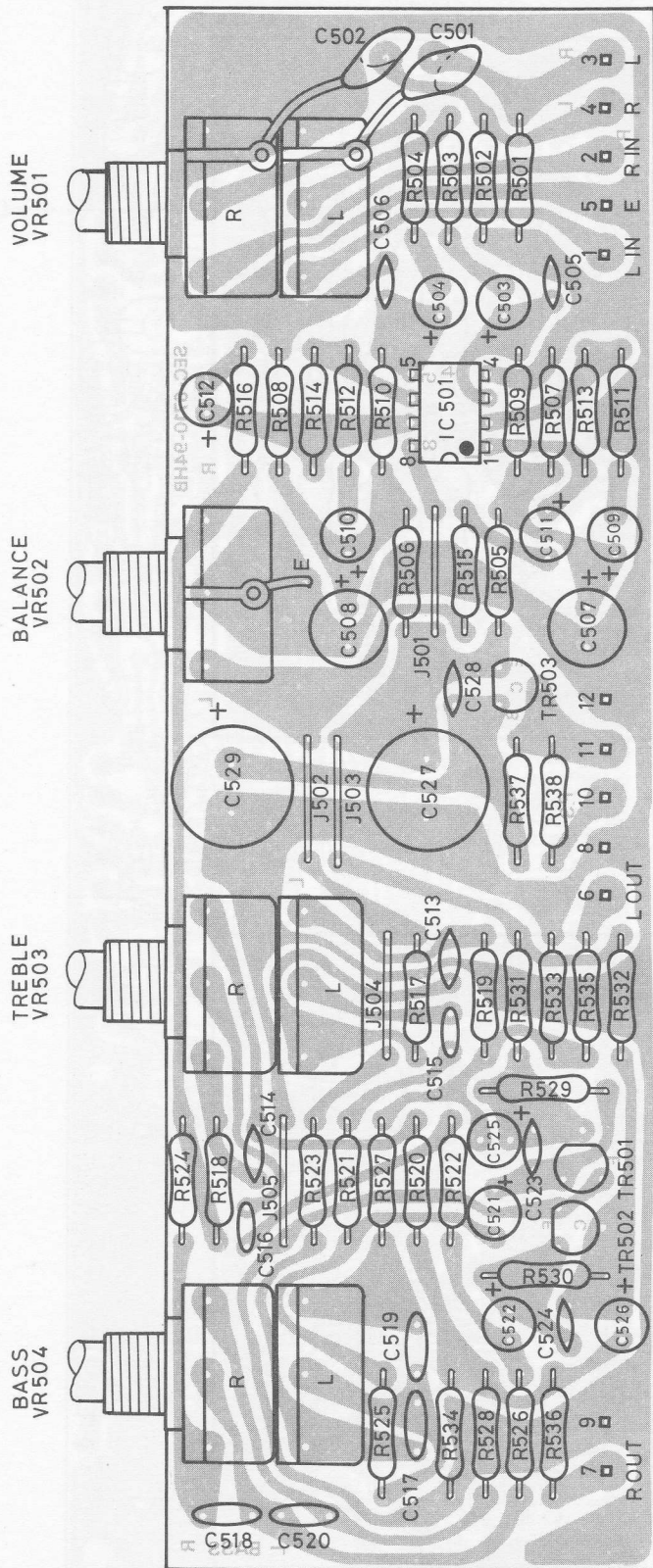

BOTTOM VIEW

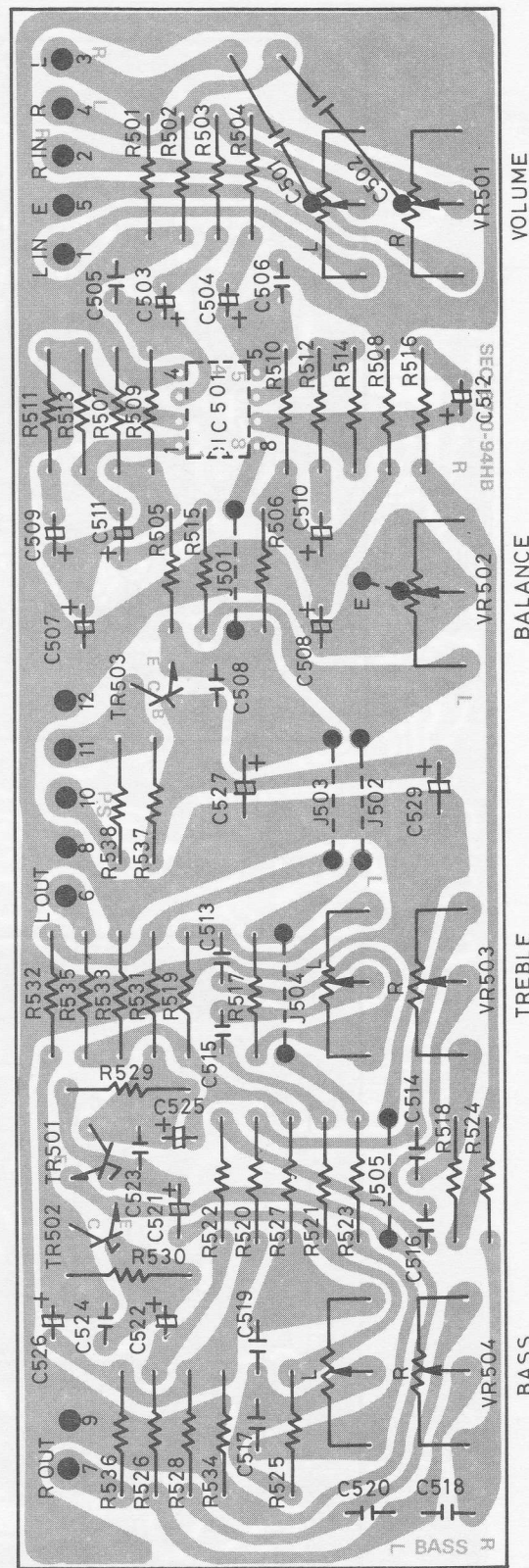

# 13. MAIN AMP P.C.B. (TOP & BOTTOM VIEWS)

TOP VIEW

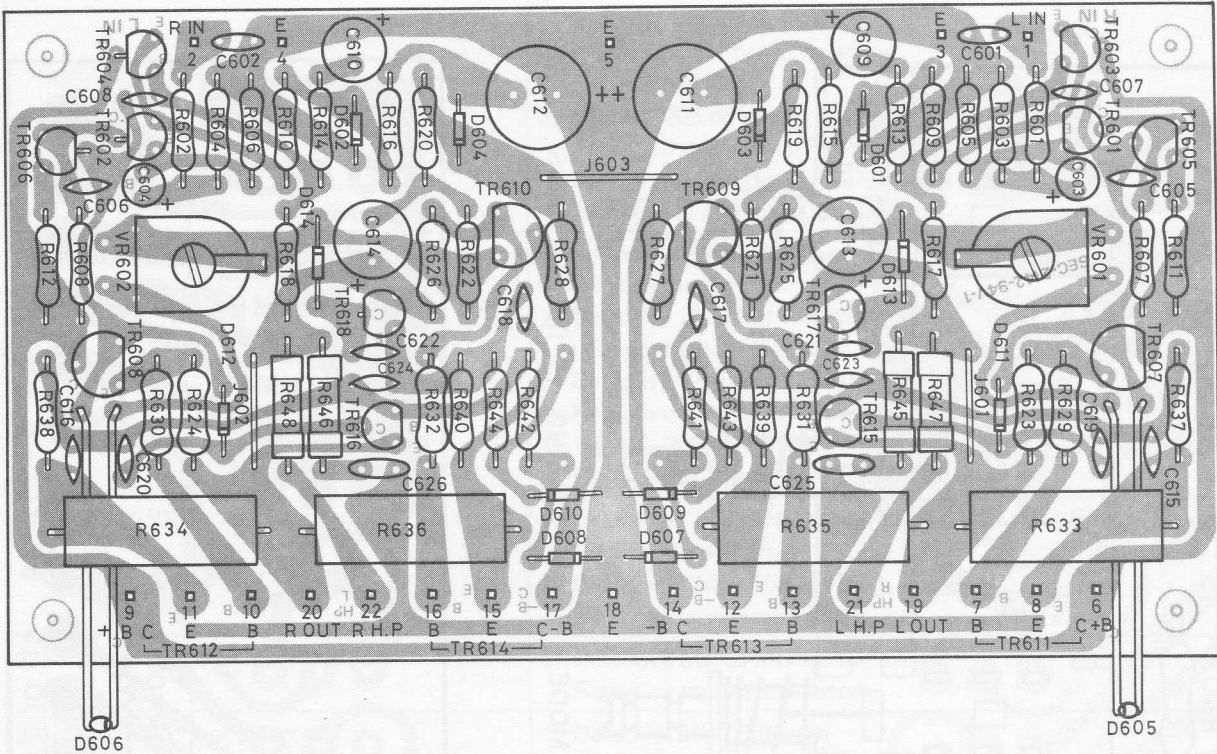

BOTTOM VIEW

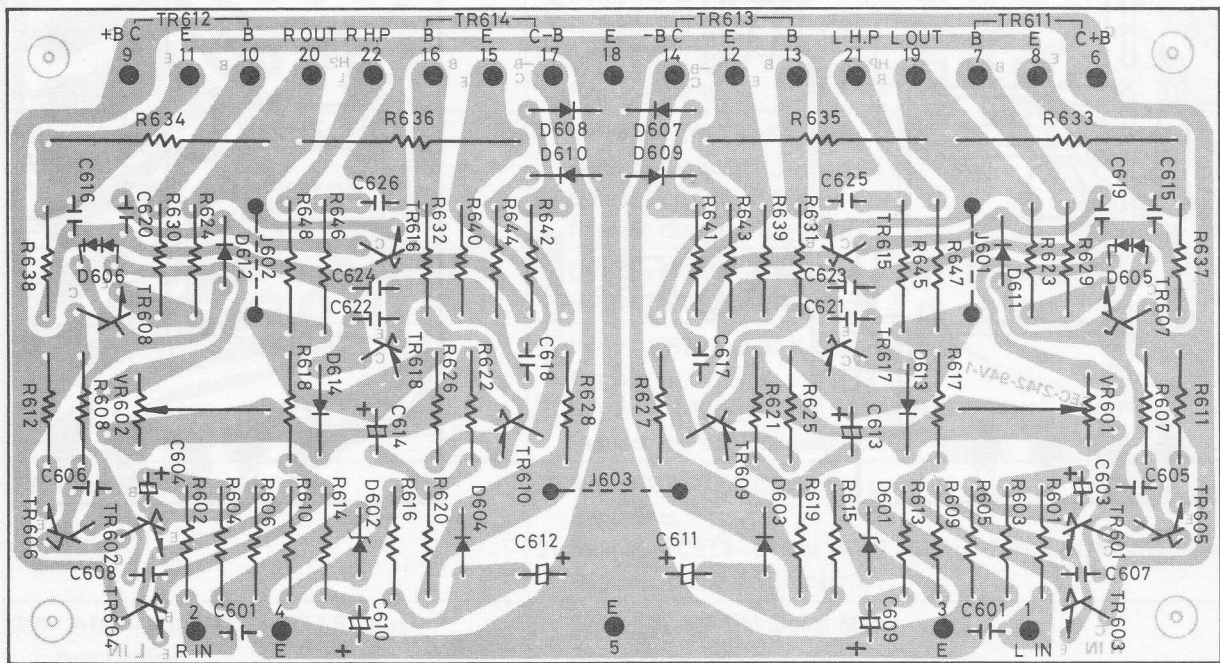

# 14. SWITCH P.C.B. (TOP & BOTTOM VIEWS)

TOP VIEW

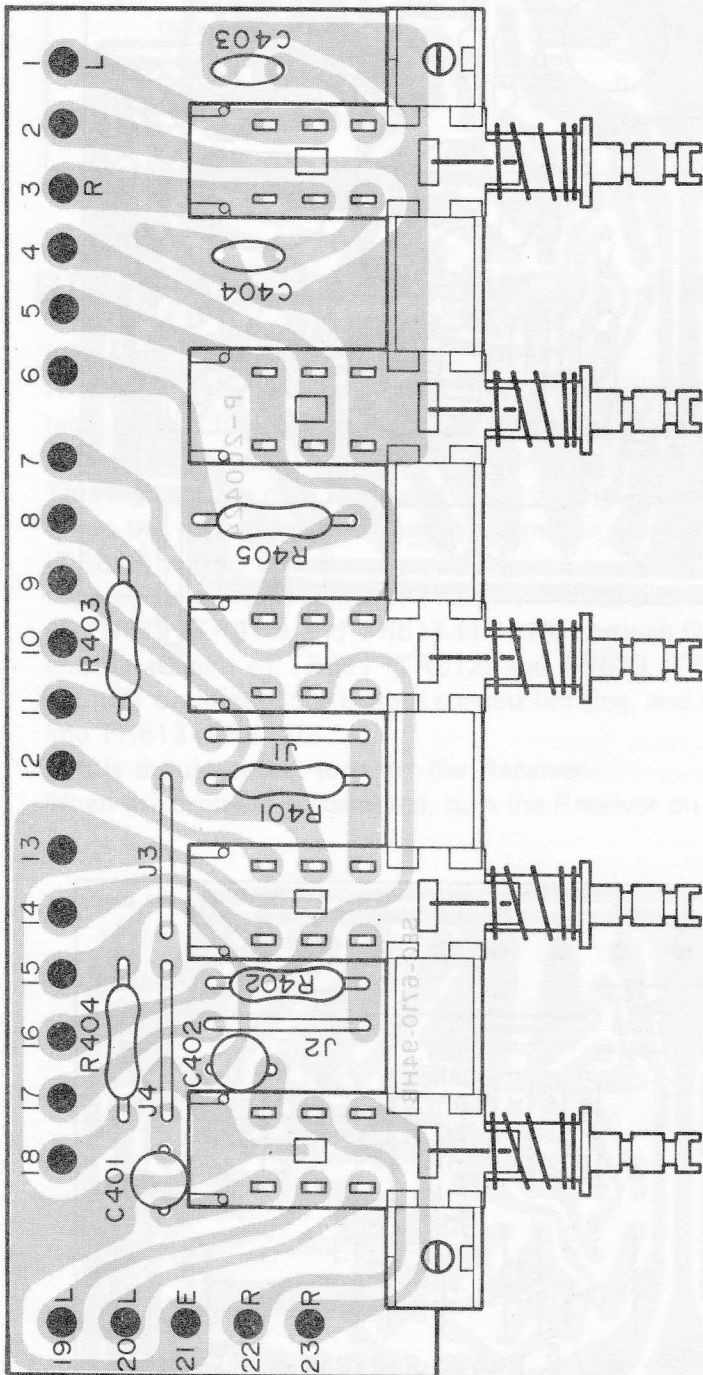

BOTTOM VIEW

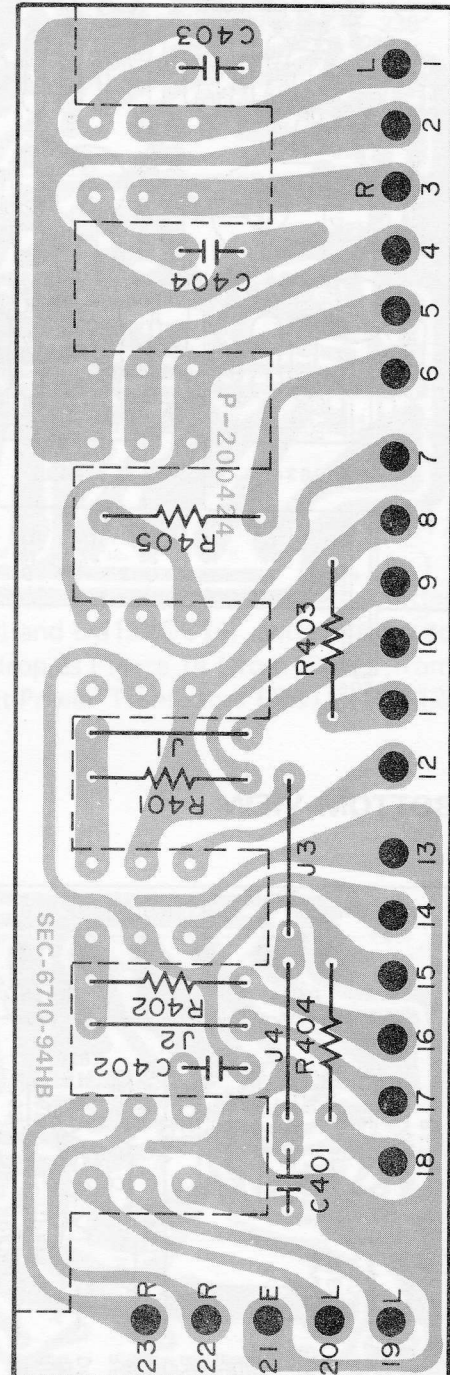

# 15. NOISE MUTING P.C.B. (TOP & BOTTOM VIEWS)

TOP VIEW

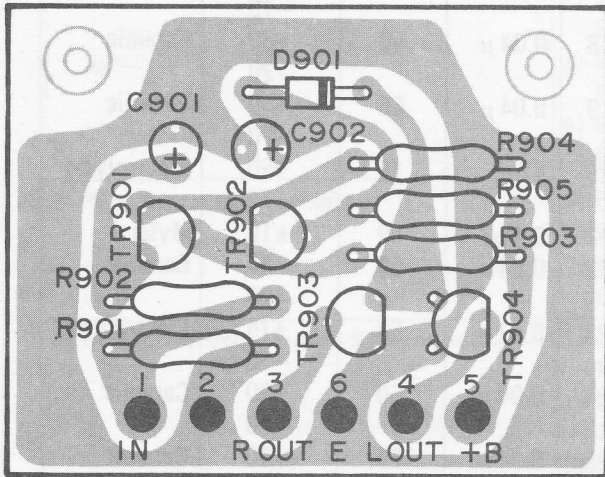

BOTTOM VIEW

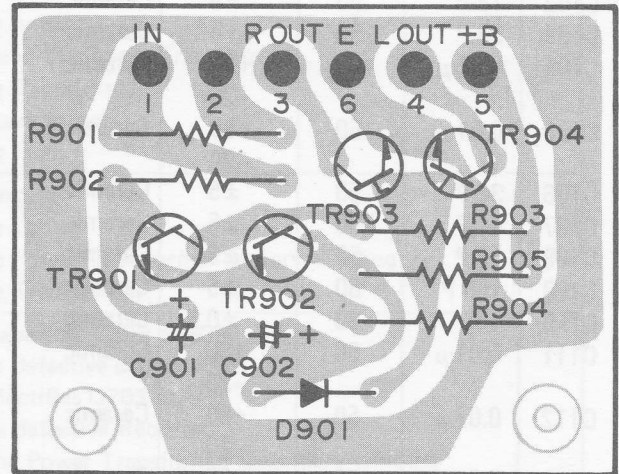

# 16. POWER SUPPLY P.C.B. (TOP & BOTTOM VIEWS)

TOP VIEW

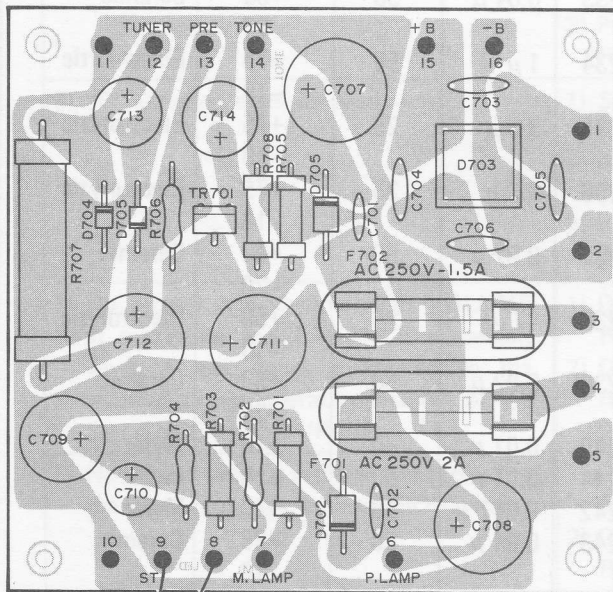

BOTTOM VIEW

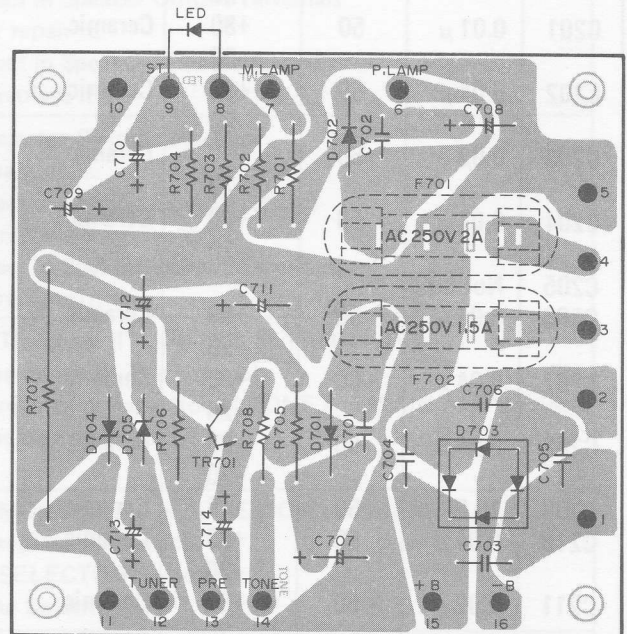

# 17. ELECTRICAL PARTS LIST

CAPACITORS					Ref. No.	Value (F)	Voltage (V)	Tolerance (%)	Material
Ref. No.	Value (F)	Voltage (V)	Tolerance (%)	Material					
C101	1 P	50	±0.5	Ceramic	C216	0.04 $\mu$	50	+80 -20	Ceramic
C102	18 P	50	±5	Ceramic	C217	220 $\mu$	16	+50 -10	Electrolytic
C103	30 P	50	±5	Ceramic	C218	0.04 $\mu$	50	+80 -20	Ceramic
C104	0.01 $\mu$	50	+80 -20	Ceramic	C219	0.04 $\mu$	50	+80 -20	Ceramic
C105	0.01 $\mu$	50	+80 -20	Ceramic	C220	47 $\mu$	16	+50 -10	Electrolytic
C106	30 P	50	±5	Ceramic	C221	0.1 $\mu$	50	±10	Mylar
C107	10 P	50	±5	Ceramic	C222	0.04 $\mu$	50	+80 -20	Ceramic
C108	18 P	50	±5	Ceramic	C223	0.47 $\mu$	50	+75 -10	Electrolytic
C109	150 P	50	±5	Ceramic	C224	0.04 $\mu$	50	+80 -20	Ceramic
C110	1 P	50	±0.5	Ceramic	C225	0.04 $\mu$	50	+80 -20	Ceramic
C111	0.01 $\mu$	50	+80 -20	Ceramic	C226	0.04 $\mu$	50	+80 -20	Ceramic
C112	0.01 $\mu$	50	+80 -20	Ceramic	C227	0.01 $\mu$	50	±10	Mylar
C113	0.01 $\mu$	50	+80 -20	Ceramic	C228	0.04 $\mu$	50	+80 -20	Ceramic
C114	18 P	50	±5	Ceramic	C229	10 P	50	±5	Ceramic
C115	2 P	50	±0.5	Ceramic	C230	340 P	50	±5	Polystyrene
C116	7 P	50	±0.5	Ceramic	C231	0.022 $\mu$	50	±10	Mylar
C117	15 P	50	±5	Ceramic	C232	0.04 $\mu$	50	+80 -20	Ceramic
C118	15 P	50	±5	Ceramic	C233	0.04 $\mu$	50	+80 -20	Ceramic
C119	0.02 $\mu$	50	+80 -20	Ceramic	C234	1 $\mu$	50	+75 -10	Electrolytic
C120	0.0047 $\mu$	50	+80 -20	Ceramic	C235	3.3 $\mu$	25	+75 -10	Electrolytic
C201	0.01 $\mu$	50	+80 -20	Ceramic	C236	3.3 $\mu$	25	+75 -10	Electrolytic
C202	0.04 $\mu$	50	+80 -20	Ceramic	C237	0.02 $\mu$	50	+80 -20	Ceramic
C203	0.02 $\mu$	50	+80 -20	Ceramic	C238	47 $\mu$	16	+50 -10	Electrolytic
C204	0.01 $\mu$	50	+80 -20	Ceramic	C239	0.02 $\mu$	50	+80 -20	Ceramic
C205	Not used				C240	0.01 $\mu$	50	±10	Mylar
C206	0.01 $\mu$	50	+80 -20	Ceramic	C241	0.01 $\mu$	50	±10	Mylar
C207	0.04 $\mu$	50	+80 -20	Ceramic	C242	0.047 $\mu$	50	±10	Mylar
C208	0.04 $\mu$	50	+80 -20	Ceramic	C243	0.04 $\mu$	50	+80 -20	Ceramic
C209	10 P	50	±5	Ceramic	C244	100 $\mu$	10	+50 -10	Electrolytic
C210	0.04 $\mu$	50	+80 -20	Ceramic	C245	1 $\mu$	50	+75 -10	Electrolytic
C211	0.02 $\mu$	50	+80 -20	Ceramic	C246	0.04 $\mu$	50	+80 -20	Ceramic
C212	100 P	50	±5	Ceramic					
C213	0.02 $\mu$	50	+80 -20	Ceramic					
C214	0.02 $\mu$	50	+80 -20	Ceramic					
C215	0.04 $\mu$	50	+80 -20	Ceramic					



Ref. No.	Value (F)	Voltage (V)	Tolerance (%)	Material	Ref. No.	Value (F)	Voltage (V)	Tolerance (%)	Material
C247	1 $\mu$	50	+75 -10	Electrolytic	C306	47 $\mu$	25	+50 -10	Electrolytic
C248	2.2 $\mu$	25	+75 -10	Electrolytic	C307	10 $\mu$	25	+50 -10	Electrolytic
C249	330 P	50	$\pm$ 5	Ceramic	C308	10 $\mu$	25	+50 -10	Electrolytic
C250	10 $\mu$	16	+50 -10	Electrolytic	C309	2000 P	50	$\pm$ 5	Polystyrene
C251	0.47 $\mu$	50	+75 -10	Electrolytic	C310	2000 P	50	$\pm$ 5	Polystyrene
C252	220 P	50	$\pm$ 5	Ceramic	C311	0.0068 $\mu$	50	$\pm$ 10	Mylar
C253	0.47 $\mu$	50	+75 -10	Electrolytic	C312	0.0068 $\mu$	50	$\pm$ 10	Mylar
C254	0.01 $\mu$	50	$\pm$ 10	Mylar	C313	1 $\mu$	25	$\pm$ 20	Tantalum
C255	220 $\mu$	16	+50 -10	Electrolytic	C314	1 $\mu$	25	$\pm$ 20	Tantalum
C256	10 $\mu$	16	+50 -10	Electrolytic	C315	330 $\mu$	35	+50 -10	Electrolytic
C257	680 P	50	$\pm$ 5	Polystyrene	C401	330 P	50	$\pm$ 5	Polystyrene
C258	0.047 $\mu$	50	$\pm$ 10	Mylar	C402	330 P	50	$\pm$ 5	Polystyrene
C259	0.0018 $\mu$	50	$\pm$ 10	Mylar	C403	0.01 $\mu$	50	$\pm$ 10	Mylar
C260	0.0018 $\mu$	50	$\pm$ 10	Mylar	C404	0.01 $\mu$	50	$\pm$ 10	Mylar
C261	1500 P	50	$\pm$ 5	Polystyrene	C501	0.068 $\mu$	50	$\pm$ 10	Mylar
C262	0.47 $\mu$	25	$\pm$ 20	Aluminum	C502	0.068 $\mu$	50	$\pm$ 10	Mylar
C263	0.22 $\mu$	25	$\pm$ 20	Aluminum	C503	1 $\mu$	35	$\pm$ 20	Tantalum
C264	0.1 $\mu$	50	$\pm$ 10	Mylar	C504	1 $\mu$	35	$\pm$ 20	Tantalum
C265	0.02 $\mu$	50	+80 -20	Ceramic	C505	220 P	50	$\pm$ 5	Ceramic
C266	0.47 $\mu$	50	+75 -10	Electrolytic	C506	220 P	50	$\pm$ 5	Ceramic
C267	0.47 $\mu$	50	+75 -10	Electrolytic	C507	47 $\mu$	25	+50 -10	Electrolytic
C268	0.0018 $\mu$	50	$\pm$ 10	Mylar	C508	47 $\mu$	25	+50 -10	Electrolytic
C269	0.0018 $\mu$	50	$\pm$ 10	Mylar	C509	10 $\mu$	16	+50 -10	Electrolytic
C270	0.47 $\mu$	50	+75 -10	Electrolytic	C510	10 $\mu$	16	+50 -10	Electrolytic
C271	0.47 $\mu$	50	+75 -10	Electrolytic	C511	3.3 $\mu$	50	+75 -10	Electrolytic
C272	220 P	50	$\pm$ 5	Ceramic	C512	3.3 $\mu$	50	+75 -10	Electrolytic
C273	220 P	50	$\pm$ 5	Ceramic	C513	100 P	50	$\pm$ 5	Ceramic
C274	0.47 $\mu$	50	+75 -10	Electrolytic	C514	100 P	50	$\pm$ 5	Ceramic
C275	0.47 $\mu$	50	+75 -10	Electrolytic	C515	0.0012 $\mu$	50	$\pm$ 10	Mylar
C276	470 $\mu$	16	+50 -10	Electrolytic	C516	0.0012 $\mu$	50	$\pm$ 10	Mylar
C277	220 $\mu$	16	+50 -10	Electrolytic	C517	0.033 $\mu$	50	$\pm$ 10	Mylar
C301	470 P	50	$\pm$ 5	Ceramic	C518	0.033 $\mu$	50	$\pm$ 10	Mylar
C302	470 P	50	$\pm$ 5	Ceramic	C519	0.033 $\mu$	50	$\pm$ 10	Mylar
C303	0.22 $\mu$	25	$\pm$ 20	Tantalum	C520	0.033 $\mu$	50	$\pm$ 10	Mylar
C304	0.22 $\mu$	25	$\pm$ 20	Tantalum	C521	1 $\mu$	50	+75 -10	Electrolytic
C305	47 $\mu$	25	+50 -10	Electrolytic	C522	1 $\mu$	50	+75 -10	Electrolytic
					C523	25 P	50	$\pm$ 5	Ceramic
					C524	25 P	50	$\pm$ 5	Ceramic
					C525	1 $\mu$	50	+75 -10	Electrolytic

Ref. No.	Value (F)	Voltage (V)	Tolerance (%)	Material
C526	1 $\mu$	50	+75 -10	Electrolytic
C527	220 $\mu$	35	+50 -10	Electrolytic
C528	0.02 $\mu$	50	+80 -20	Ceramic
C529	220 $\mu$	35	+50 -10	Electrolytic
C601	0.0022 $\mu$	50	$\pm$ 10	Mylar
C602	0.0022 $\mu$	50	$\pm$ 10	Mylar
C603	2.2 $\mu$	50	+75 -10	Electrolytic
C604	2.2 $\mu$	50	+75 -10	Electrolytic
C605	56 P	50	$\pm$ 5	Ceramic
C606	56 P	50	$\pm$ 5	Ceramic
C607	5 P	50	$\pm$ 5	Ceramic
C608	5 P	50	$\pm$ 5	Ceramic
C609	47 $\mu$	10	+50 -10	Electrolytic
C610	47 $\mu$	10	+50 -10	Electrolytic
C611	220 $\mu$	35	+50 -10	Electrolytic
C612	220 $\mu$	35	+50 -10	Electrolytic
C613	100 $\mu$	35	+50 -10	Electrolytic
C614	100 $\mu$	35	+50 -10	Electrolytic
C615	0.022 $\mu$	50	+80 -20	Ceramic
C616	0.022 $\mu$	50	+80 -20	Ceramic
C617	0.022 $\mu$	50	+80 -20	Ceramic
C618	0.022 $\mu$	50	+80 -20	Ceramic
C619	0.0047 $\mu$	50	$\pm$ 10	Ceramic
C620	0.0047 $\mu$	50	$\pm$ 10	Ceramic
C621	0.0047 $\mu$	50	$\pm$ 10	Ceramic
C622	0.0047 $\mu$	50	$\pm$ 10	Ceramic
C623	0.047 $\mu$	50	+80 -20	Ceramic
C624	0.047 $\mu$	50	+80 -20	Ceramic
C625	0.022 $\mu$	50	$\pm$ 10	Mylar
C626	0.022 $\mu$	50	$\pm$ 10	Mylar
C701	0.04 $\mu$	50	+80 -20	Ceramic
C702	0.04 $\mu$	50	+80 -20	Ceramic
C703	0.04 $\mu$	100	+80 -20	Ceramic

Ref. No.	Value (F)	Voltage (V)	Tolerance (%)	Material
C704	0.04 $\mu$	100	+80 -20	Ceramic
C705	0.04 $\mu$	100	+80 -20	Ceramic
C706	0.04 $\mu$	100	+80 -20	Ceramic
C707	1000 $\mu$	50	+50 -10	Electrolytic
C708	1000 $\mu$	16	+50 -10	Electrolytic
C709	470 $\mu$	16	+50 -10	Electrolytic
C710	220 $\mu$	16	+50 -10	Electrolytic
C711	470 $\mu$	50	+50 -10	Electrolytic
C712	470 $\mu$	35	+50 -10	Electrolytic
C713	220 $\mu$	16	+50 -10	Electrolytic
C714	220 $\mu$	35	+50 -10	Electrolytic
C801	0.01 $\mu$	50	+80 -20	Ceramic
C802	6800 $\mu$	35	+50 -10	Electrolytic
C803	6800 $\mu$	35	+50 -10	Electrolytic
C804	0.01 $\mu$ (UK or MR Type)	125	+80 -20	Ceramic (UL)
	0.01 $\mu$ (MS Type)	125	+80 -20	Ceramic (C.S.A.)
C805	0.01 $\mu$	50	+80 -20	Ceramic
C901	1 $\mu$	50	+75 -10	Electrolytic
C902	22 $\mu$	10	+50 -10	Electrolytic

### CERAMIC FILTERS

Ref. No.	Description	R/S Part No.	Mfr's Part No.
CF201	FM Ceramic Filter (SEF-10.7MA-8)	CA-7536	P-140030
CF202	FM Ceramic Filter (SEF-10.7MA-8)	CA-7536	P-140030

### COILS & TRANSFORMERS

Ref. No.	Description	R/S Part No.	Mfr's Part No.
L101	FM ANT Coil	CA-3594	P-110050
L102	FM IF Trap Coil	CB-2171	P-360003

Ref. No.	Description	R/S Part No.	Mfr's Part No.
L103	FM RF Coil	CA-3371	P-340033
L104	FM IF Trap Coil	CB-2171	P-360003
L105	FM OSC Coil	CA-4720	P-120043
L201	Inductor (2.2 $\mu$ H)	C-0708	P-360021
L202	Inductor (18 $\mu$ H)	C-0853	P-360029
L203	AM OSC Coil	CA-4721	P-120058
L204	Inductor (2.2 $\mu$ H)	C-0708	P-360021
L801	Balun Coil	CA-2942	P-110012
L802	AM Antenna Coil	CA-3853	P-110080
T101	FM IFT (7F-007)	CA-7428	P-130010
T201	FM IFT (3F-035)	CA-7820	P-140035
T202	AM IFT (0A-011)	CA-7281	P-130011
T203	AM IFT (0A-010)	CA-7428	P-130010
T204	AM IFT (0A-052)	CA-7821	P-130052
T801	Power Transformer (UL)	TA-0651	P-100463
T801	Power Transformer (C.S.A.)		P-100505

### DIODES

Ref. No.	Description	R/S Part No.	Manufacturer
D101	Varicap ITT-410	DX-0307	ITT
D201	1N-60P or 1S-188	DX-0162 DX-0551	UNIZON SANYO, HITACHI
D202	1N-60P or 1S-188	DX-0162 DX-0551	UNIZON SANYO, HITACHI
D203	ITT-73N	DX-1008	ITT
D204	1N-60P or 1S-188	DX-0162 DX-0551	UNIZON SANYO, HITACHI
D205	1N-60P or 1S-188	DX-0162 DX-0551	UNIZON SANYO, HITACHI
D206	MV-13	DX-0352	OIZUMI
D207	1N-60P or 1S-188	DX-0162 DX-0551	UNIZON SANYO, HITACHI
D208	ITT-73N	DX-1008	ITT
D601	Zener WZ-130	DX-0537	JRC
D602	Zener WZ-130	DX-0537	JRC
D603	KB162C5	DX-0312	UNIZON
D604	KB162C5	DX-0312	UNIZON
D605	MV-13	DX-0352	OIZUMI
D606	MV-13	DX-0352	OIZUMI
D607	ITT-73N	DX-1008	ITT
D608	ITT-73N	DX-1008	ITT
D609	ITT-73N	DX-1008	ITT
D610	ITT-73N	DX-1008	ITT
D611	ITT-73N	DX-1008	ITT
D612	ITT-73N	DX-1008	ITT
D613	ITT-73N	DX-1008	ITT
D614	ITT-73N	DX-1008	ITT

Ref. No.	Description	R/S Part No.	Manufacturer
D701	SR-1K-2 or 10E-1	DX-0475	UNIZON
D702	SR-1K-2 or 10E-1	DX-0475	INTER-RECTIFIER
D703	S-4VB	DX-1009	UNIZON
D704	Zener WZ-130	DX-0537	RECTIFIER
D705	Zener WZ-320	DX-1010	FUZI
D901	ITT-73N	DX-1008	JRC
			ITT

### FILTER

Ref. No.	Description	R/S Part No.	Mfr's Part No.
LPF	Low Pass Filter	CA-3373	P-510006

### INTEGRATED CIRCUITS

Ref. No.	Description	R/S Part No.	Manufacturer
IC201	HA-11211	MX-3448	HITACHI
IC202	LA-3350(S)	MX-3215	SANYO
IC301	NJM4558DD	MX-3447	JRC
IC501	NJM4558DF	MX-3438	JRC

### LAMPS

Ref. No.	Description	R/S Part No.	Mfr's Part No.
PL801	Dial Lamp 12 V, 0.15 A	L-0529	P-240038
PL802	Dial Lamp 12 V, 0.15 A	L-0529	P-240038
PL803	Dial Lamp 12 V, 0.15 A	L-0529	P-240038
PL804	Dial Lamp 12 V, 0.15 A	L-0529	P-240038
PL805	Meter Lamp 12 V, 0.15 A	L-0529	P-240038

### LIGHT EMITTING DIODE

Ref. No.	Description	R/S Part No.	Manufacturer
LED	GL3AR1	L-0835	SHARP

### METER

Ref. No.	Description	R/S Part No.	Mfr's Part No.
M801	AM/FM Signal Meter (200 $\mu$ A, 1.2 K ohm)	M-0365	P-230065

RESISTORS					
Ref. No.	Value (ohm)	Wattage (W)	Tolerance (%)	Material	R/S Part No.
R101	100 K	1/4	± 5	Carbon	NEE-0371
R102	330	1/4	± 5	Carbon	NEE-0159
R103	5.6 K	1/4	± 5	Carbon	NEE-0257
R104	33 K	1/4	± 5	Carbon	NEE-0324
R105	1.5 K	1/4	± 5	Carbon	NEE-0206
R106	220 K	1/4	± 5	Carbon	NEE-0396
R107	330	1/4	± 5	Carbon	NEE-0159
R108	330	1/4	± 5	Carbon	NEE-0159
R109	10 K	1/4	± 5	Carbon	NEE-0281
R110	22 K	1/4	± 5	Carbon	NEE-0311
R111	3.3 K	1/4	± 5	Carbon	NEE-0230
R112	100 K	1/4	± 5	Carbon	NEE-0391
R113	330	1/4	± 5	Carbon	NEE-0159
R201	3.3 K	1/4	± 5	Carbon	NEE-0230
R202	560	1/4	± 5	Carbon	NEE-0176
R203	330	1/4	± 5	Carbon	NEE-0159
R204	330	1/4	± 5	Carbon	NEE-0159
R205	Not used				
R206	Not used				
R207	330	1/4	± 5	Carbon	NEE-0159
R208	100	1/4	± 5	Carbon	NEE-0132
R209	47	1/4	± 5	Carbon	NEE-0099
R210	10	1/4	± 5	Carbon	NEE-0063
R211	3.3 K	1/4	± 5	Carbon	NEE-0230
R212	10 K	1/4	± 5	Carbon	NEE-0281
R213	1K	1/4	± 5	Carbon	NEE-0196
R214	560	1/4	± 5	Carbon	NEE-0176
R215	100	1/4	± 5	Carbon	NEE-0132
R216	10 K	1/4	± 5	Carbon	NEE-0281
R217	22	1/4	± 5	Carbon	NEE-0078
R218	4.7 K	1/4	± 5	Carbon	NEE-0247
R219	2.2 K	1/4	± 5	Carbon	NEE-0216
R220	220	1/4	± 5	Carbon	NEE-0149
R221	8.2 K	1/4	± 5	Carbon	NEE-0271
R222	470 K	1/4	± 5	Carbon	NEE-0423
R223	1 K	1/4	± 5	Carbon	NEE-0196
R224	10 K	1/4	± 5	Carbon	NEE-0281
R225	1.8 K	1/4	± 5	Carbon	NEE-0210
R226	100	1/4	± 5	Carbon	NEE-0132
R227	10 K	1/4	± 5	Carbon	NEE-0281
R228	15 K	1/4	± 5	Carbon	NEE-0297
R229	2.2 K	1/4	± 5	Carbon	NEE-0216
R230	1.5 K	1/4	± 5	Carbon	NEE-0206
R231	4.7 K	1/4	± 5	Carbon	NEE-0247
R232	27 K	1/4	± 5	Carbon	NEE-0316
R233	4.7 K	1/4	± 5	Carbon	NEE-0247
R234	47	1/4	± 5	Carbon	NEE-0099
R235	150 K	1/4	± 5	Carbon	NEE-0384
R236	68 K	1/4	± 5	Carbon	NEE-0354
R237	47 K	1/4	± 5	Carbon	NEE-0340
R238	39 K	1/4	± 5	Carbon	NEE-0330
R239	33 K	1/4	± 5	Carbon	NEE-0324

Ref. No.	Value (ohm)	Wattage (W)	Tolerance (%)	Material	R/S Part No.
R240	33 K	1/4	± 5	Carbon	NEE-0324
R241	2.2 K	1/4	± 5	Carbon	NEE-0216
R242	1.5 K	1/4	± 5	Carbon	NEE-0206
R243	1 K	1/4	± 5	Carbon	NEE-0196
R244	5.6 K	1/4	± 5	Carbon	NEE-0257
R245	10 K	1/4	± 5	Carbon	NEE-0281
R246	39 K	1/4	± 5	Carbon	NEE-0330
R247	1.5 M	1/4	± 5	Carbon	NEE-0450
R248	4.7 K	1/4	± 5	Carbon	NEE-0247
R249	1 K	1/4	± 5	Carbon	NEE-0196
R250	39 K	1/4	± 5	Carbon	NEE-0330
R251	220	1/4	± 5	Carbon	NEE-0149
R252	10 K	1/4	± 5	Carbon	NEE-0281
R253	47 K	1/4	± 5	Carbon	NEE-0340
R254	10 K	1/4	± 5	Carbon	NEE-0281
R255	12 K	1/4	± 5	Carbon	NEE-0288
R256	33 K	1/4	± 5	Carbon	NEE-0324
R257	Not used				
R258	3.3 K	1/4	± 5	Carbon	NEE-0230
R259	3.3 K	1/4	± 5	Carbon	NEE-0230
R260	1.2 K	1/2	± 5	Carbon	NEF-0199
R261	1.8 K	1/4	± 5	Carbon	NEE-0210
R262	4.7 K	1/4	± 5	Carbon	NEE-0247
R263	8.2 K	1/4	± 5	Carbon	NEE-0271
R264	1 K	1/4	± 5	Carbon	NEE-0196
R265	47 K	1/4	± 5	Carbon	NEE-0340
R266	3.3 K	1/4	± 5	Carbon	NEE-0230
R267	3.3 K	1/4	± 5	Carbon	NEE-0230
R268	3.3 K	1/4	± 5	Carbon	NEE-0230
R269	3.3 K	1/4	± 5	Carbon	NEE-0230
R270	100 K	1/4	± 5	Carbon	NEE-0371
R271	100 K	1/4	± 5	Carbon	NEE-0371
R272	1.5 M	1/4	± 5	Carbon	NEE-0450
R273	1.5 M	1/4	± 5	Carbon	NEE-0450
R274	4.7 K	1/4	± 5	Carbon	NEE-0247
R275	4.7 K	1/4	± 5	Carbon	NEE-0247
R276	820	1/4	± 5	Carbon	NEE-0187
R277	820	1/4	± 5	Carbon	NEE-0187
R278	39 K	1/4	± 5	Carbon	NEE-0330
R279	39 K	1/4	± 5	Carbon	NEE-0330
R280	100	1/4	± 5	Carbon	NEE-0132
R281	47	1/4	± 5	Carbon	NEE-0099
R282	100	1/4	± 5	Carbon	NEE-0099
R301	1.5 K	1/4	± 5	Carbon	NEE-0206
R302	1.5 K	1/4	± 5	Carbon	NEE-0206
R303	100 K	1/4	± 5	Carbon	NEE-0371
R304	100 K	1/4	± 5	Carbon	NEE-0371
R305	10 K	1/4	± 5	Carbon	NEE-0281
R306	10 K	1/4	± 5	Carbon	NEE-0281
R307	10 K	1/4	± 5	Carbon	NEE-0281
R308	10 K	1/4	± 5	Carbon	NEE-0281
R309	100 K	1/4	± 5	Carbon	NEE-0371
R310	100 K	1/4	± 5	Carbon	NEE-0371

Ref. No.	Value (ohm)	Wattage (W)	Tolerance (%)	Material	R/S Part No.	Ref. No.	Value (ohm)	Wattage (W)	Tolerance (%)	Material	R/S Part No.
R311	560	1/4	±5	Carbon	NEE-0176	R601	1 K	1/4	±5	Carbon	NEE-0196
R312	560	1/4	±5	Carbon	NEE-0176	R602	1 K	1/4	±5	Carbon	NEE-0196
R313	33 K	1/4	±5	Carbon	NEE-0324	R603	220 K	1/4	±5	Carbon	NEE-0396
R314	33 K	1/4	±5	Carbon	NEE-0324	R604	220 K	1/4	±5	Carbon	NEE-0396
R315	330 K	1/4	±5	Carbon	NEE-0410	R605	33 K	1/4	±5	Carbon	NEE-0324
R316	330 K	1/4	±5	Carbon	NEE-0410	R606	33 K	1/4	±5	Carbon	NEE-0324
R317	10 K	1/4	±5	Carbon	NEE-0281	R607	2.7 K	1/4	±5	Carbon	NEE-0224
R318	10 K	1/4	±5	Carbon	NEE-0281	R608	2.7 K	1/4	±5	Carbon	NEE-0224
R319	4.7 K	1/4	±5	Carbon	NEE-0247	R609	15 K	1/4	±5	Carbon	NEE-0297
R320	4.7 K	1/4	±5	Carbon	NEE-0247	R610	15 K	1/4	±5	Carbon	NEE-0297
R321	680	1/4	±5	Carbon	NEE-0183	R611	56	1/4	±5	Carbon	NEE-0107
R401	4.7 K	1/4	±5	Carbon	NEE-0247	R612	56	1/4	±5	Carbon	NEE-0107
R402	4.7 K	1/4	±5	Carbon	NEE-0247	R613	2.2 K	1/4	±5	Carbon	NEE-0216
R403	4.7 K	1/4	±5	Carbon	NEE-0247	R614	2.2 K	1/4	±5	Carbon	NEE-0216
R404	4.7 K	1/4	±5	Carbon	NEE-0247	R615	5.6 K	1/4	±5	Carbon	NEE-0257
R405	10 K	1/4	±5	Carbon	NEE-0281	R616	5.6 K	1/4	±5	Carbon	NEE-0257
R501	6.8 K	1/4	±5	Carbon	NEE-0262	R617	33 K	1/4	±5	Carbon	NEE-0324
R502	6.8 K	1/4	±5	Carbon	NEE-0262	R618	33 K	1/4	±5	Carbon	NEE-0324
R503	1 K	1/4	±5	Carbon	NEE-0196	R619	1.8 K	1/4	±5	Carbon	NEE-0210
R504	1 K	1/4	±5	Carbon	NEE-0196	R620	1.8 K	1/4	±5	Carbon	NEE-0210
R505	10 K	1/4	±5	Carbon	NEE-0281	R621	2.7 K	1/4	±5	Carbon	NEE-0224
R506	10 K	1/4	±5	Carbon	NEE-0281	R622	2.7 K	1/4	±5	Carbon	NEE-0224
R507	10 K	1/4	±5	Carbon	NEE-0281	R623	100	1/2	±5	Carbon	NEF-0132
R508	10 K	1/4	±5	Carbon	NEE-0281					(UL)	
R509	220 K	1/4	±5	Carbon	NEE-0396	R623	100	1	±5	Metal Oxide	
R510	220 K	1/4	±5	Carbon	NEE-0396					(C.S.A.)	
R511	2.7 K	1/4	±5	Carbon	NEE-0224	R624	100	1/2	±5	Carbon	NEF-0132
R512	2.7 K	1/4	±5	Carbon	NEE-0224					(UL)	
R513	18 K	1/4	±5	Carbon	NEE-0303	R624	100	1	±5	Metal Oxide	
R514	18 K	1/4	±5	Carbon	NEE-0303					(C.S.A.)	
R515	1.5 K	1/4	±5	Carbon	NEE-0206	R625	100	1/2	±5	Carbon	NEF-0132
R516	1.5 K	1/4	±5	Carbon	NEE-0206					(UL)	
R517	4.7 K	1/4	±5	Carbon	NEE-0247	R625	100	1	±5	Metal Oxide	
R518	4.7 K	1/4	±5	Carbon	NEE-0247					(C.S.A.)	
R519	4.7 K	1/4	±5	Carbon	NEE-0247	R626	100	1/2	±5	Carbon	NEF-0132
R520	4.7 K	1/4	±5	Carbon	NEE-0247					(UL)	
R521	1 K	1/4	±5	Carbon	NEE-0196	R626	100	1	±5	Metal Oxide	
R522	1 K	1/4	±5	Carbon	NEE-0196					(C.S.A.)	
R523	15 K	1/4	±5	Carbon	NEE-0297	R627	18	1/2	±5	Carbon	NEF-0075
R524	15 K	1/4	±5	Carbon	NEE-0297	R628	18	1/2	±5	Carbon	NEF-0075
R525	15 K	1/4	±5	Carbon	NEE-0297	R629	4.7	1/2	±5	Carbon	NEF-0047
R526	15 K	1/4	±5	Carbon	NEE-0297					(UL)	
R527	15 K	1/4	±5	Carbon	NEE-0297	R629	4.7	1	±5	Metal Oxide	
R528	15 K	1/4	±5	Carbon	NEE-0297					(C.S.A.)	
R529	1.8 M	1/4	±5	Carbon	NEE-0521	R630	4.7	1/2	±5	Carbon	NEF-0047
R530	1.8 M	1/4	±5	Carbon	NEE-0521					(UL)	
R531	4.7 K	1/4	±5	Carbon	NEE-0247	R629	4.7	1	±5	Metal Oxide	
R532	4.7 K	1/4	±5	Carbon	NEE-0247					(C.S.A.)	
R533	100 K	1/4	±5	Carbon	NEE-0371	R630	4.7	1/2	±5	Carbon	NEF-0047
R534	100 K	1/4	±5	Carbon	NEE-0371					(UL)	
R535	1 K	1/4	±5	Carbon	NEE-0196	R630	4.7	1	±5	Metal Oxide	
R536	1 K	1/4	±5	Carbon	NEE-0196					(C.S.A.)	
R537	47 K	1/4	±5	Carbon	NEE-0340						
R538	1 K	1/4	±5	Carbon	NEE-0196						

Ref. No.	Value (ohm)	Wattage (W)	Tolerance (%)	Material	R/S Part No.
R631	4.7	1/2	± 5	Carbon (UL)	NEF-0047
R631	4.7	1	± 5	Metal Oxide (C.S.A.)	
R632	4.7	1/2	± 5	Carbon (UL)	NEF-0047
R632	4.7	1	± 5	Metal Oxide (C.S.A.)	
R633	0.5	5	± 5	Cement	NEK-0010
R634	0.5	5	± 5	Cement	NEK-0010
R635	0.5	5	± 5	Cement	NEK-0010
R636	0.5	5	± 5	Cement	NEK-0010
R637	120	1/4	± 5	Carbon	NEE-0136
R638	120	1/4	± 5	Carbon	NEE-0136
R639	120	1/4	± 5	Carbon	NEE-0136
R640	120	1/4	± 5	Carbon	NEE-0136
R641	1 K	1/4	± 5	Carbon	NEE-0196
R642	1 K	1/4	± 5	Carbon	NEE-0196
R643	1 K	1/4	± 5	Carbon	NEE-0196
R644	1 K	1/4	± 5	Carbon	NEE-0196
R645	12	1	± 5	Metal Oxide	NEG-0067
R646	12	1	± 5	Metal Oxide	NEG-0067
R647	220	1	± 5	Metal Oxide	NEG-0049
R648	220	1	± 5	Metal Oxide	NEG-0149
R701	15	1	± 5	Metal Oxide	NEG-0074
R702	22	1/2	± 5	Carbon	NEF-0078
R703	470	1	± 5	Metal Oxide	NEG-0169
R704	10 K	1/4	± 5	Carbon	NEE-0281
R705	22	1	± 5	Metal Oxide	NEG-0078
R706	560	1/2	± 5	Carbon	NEF-0176
R707	330	4	± 5	Metal Oxide	
R708	220	1	± 5	Metal Oxide	NEG-0149
R801	10 K	1/4	± 5	Carbon	NEE-0281
R802	10 K	1/4	± 5	Carbon	NEE-0281
R803	100 K	1/4	± 5	Carbon	NEE-0371
R804	100 K	1/4	± 5	Carbon	NEE-0371
R805	2.2 M	1/2	± 5	Carbon	NEF-0454
R901	100 K	1/4	± 5	Carbon	NEE-0371
R902	22 K	1/4	± 5	Carbon	NEE-0311
R903	10 K	1/4	± 5	Carbon	NEE-0281
R904	47	1/4	± 5	Carbon	NEE-0099
R905	10 K	1/4	± 5	Carbon	NEE-0281
R906	100 K	1/4	± 5	Carbon	NEE-0371

### JUMPER WIRES

Ref. No.	Description	R/S Part No.	Mfr's Part No.
J101(J1)	Jumper wire (P = 12.5 m/m)	HB-7049	P-320128
J102(J2)	Jumper wire (P = 12.5 m/m)	HB-7049	P-320128
J103(J3)	Jumper wire (P = 12.5 m/m)	HB-7049	P-320128
J201(J4)	Jumper wire (P = 12.5 m/m)	HB-7049	P-320128
J202(J5)	Jumper wire (P = 12.5 m/m)	HB-7049	P-320128
J203(J6)	Jumper wire (P = 12.5 m/m)	HB-7049	P-320128
J204(J7)	Jumper wire (P = 12.5 m/m)	HB-7049	P-320128
J205(J8)	Jumper wire (P = 12.5 m/m)	HB-7049	P-320128
J206(J9)	Jumper wire (P = 12.5 m/m)	HB-7049	P-320128
J401(J1)	Jumper wire (P = 12.5 m/m)	HB-7049	P-320128
J402(J2)	Jumper wire (P = 12.5 m/m)	HB-7049	P-320128
J403(J3)	Jumper wire (P = 12.5 m/m)	HB-7049	P-320128
J404(J4)	Jumper wire (P = 12.5 m/m)	HB-7049	P-320128
J501	Jumper wire (P = 12.5 m/m)	HB-7049	P-320128
J502	Jumper wire (P = 12.5 m/m)	HB-7049	P-320128
J503	Jumper wire (P = 12.5 m/m)	HB-7049	P-320128
J504	Jumper wire (P = 12.5 m/m)	HB-7049	P-320128
J505	Jumper wire (P = 12.5 m/m)	HB-7049	P-320128
J601	Jumper wire (P = 12.5 m/m)	HB-7049	P-320128
J602	Jumper wire (P = 12.5 m/m)	HB-7049	P-320128
J603	Jumper wire (P = 15 m/m)	HB-7050	P-320195

SWITCHES			
Ref. No.	Description	R/S Part No.	Mfr's Part No.
Ss1—Ss7	SELECTOR	S-1291	P-180250
Sp1—Sp4	SPEAKER	S-1292	P-180251
Ps1—Ps2	POWER	S-7047	P-180044
S1	MUTE	S-7343	P-180249
S2	MONO	S-7343	P-180249
S3	FM 25 $\mu$ S	S-7343	P-180249
S4	TAPE MON	S-7343	P-180249
S5	LOUDNESS	S-7343	P-180249

THERMAL PROTECTOR			
Ref. No.	Description	R/S Part No.	Mfr's Part No.
TP801	UI-2 (90°C, 125 V/6A)		P-290019

FUSES			
Ref. No.	Description	R/S Part No.	Mfr's Part No.
F701	2 A, 250 V Quick	HF-1115	P-250015
F702	1.5 A, 250 V Quick	HF-0004	P-250007
F801	3 A, 250 V Quick	HF-0091	P-250038

TRANSISTORS		
Ref. No.	Type No.	Manufacturer
TR101	FET2KS41(F)	SANYO
TR102	2SC1674(L, K)	NEC
TR103	2SC1674(L, K)	NEC
TR201	2SC930(E, D)	SANYO
TR202	2SC930(E, D)	SANYO
TR203	2SC929(E, D)	SANYO
TR204	2SC929(E, D)	SANYO
TR205	2SC536(H)	SANYO
TR206	2SC536(H)	SANYO
TR207	2SC900(E, U)	NEC
TR208	2SC900(E, U)	NEC
TR209	2SC536(H)	SANYO
TR501	2SC900(E, U)	NEC
TR502	2SC900(E, U)	NEC
TR503	2SC945A(P)	NEC
TR601	2SC1570(G)	SANYO
TR602	2SC1570(G)	SANYO
TR603	2SC1570(G)	SANYO
TR604	2SC1570(G)	SANYO
TR605	2SA659(D, E)	SANYO
TR606	2SA659(D, E)	SANYO
TR607	2SD438(D, E)	SANYO
TR608	2SD438(D, E)	SANYO
TR609	2SB560(D, E)	SANYO
TR610	2SB560(D, E)	SANYO
TR611	2SD315(D, E) V10	SANYO

Ref. No.	Type No.	Manufacturer	
TR612	2SD315(D, E) V10	SANYO	
TR613	2SB509(D, E) V10	SANYO	
TR614	2SB509(D, E) V10	SANYO	
TR615	2SC1175(D, E) V10	SANYO	
TR616	2SC1175(D, E) V10	SANYO	
TR617	2SA659(D, E) V10	SANYO	
TR618	2SA659(D, E) V10	SANYO	
TR701	2SD571(L, K)	NEC	
TR901	2SC923(E, U)	NEC	
TR902	2SC923(E, U)	NEC	
TR903	2SC923(E, U)	NEC	
TR904	2SC923(E, U)	NEC	

VARIABLE CAPACITORS			
Ref. No.	Description	R/S Part No.	Mfr's Part No.
VC101 -VC105	Tuning Gang C75CJ111 (Includes TC101, 103, 104 and 105.)	C-4567	P-150019
TC103	Trimmer 1PX-10	CA-0249	P-160007

VARIABLE RESISTORS			
Ref. No.	Description	R/S Part No.	Mfr's Part No.
VR201	Trimmer 10 K ohm B	P-6466	P-170249
VR202	Trimmer 47 K ohm B	P-6467	P-170252
VR203	Trimmer 47 K ohm B	P-6467	P-170252
VR204	Trimmer 1 K ohm B	P-6469	P-170245
VR205	Trimmer 4.7 K ohm B	P-6465	P-170248
VR501	Potentiometer 100 K ohm 2B x 2 (VOLUME)	P-1837	P-170266
VR502	Potentiometer 100 K ohm W (BALANCE)	P-3077	P-170267
VR503	Potentiometer 100 K ohm 1B x 2 (TREBLE)	P-2081	P-170273
VR504	Potentiometer 100 K ohm 1B x 2 (BASS)	P-2081	P-170273
VR601	Trimmer 200 ohm B		P-170243
VR602	Trimmer 200 ohm B		P-170243

# 18. EXPLODED VIEW PARTS LIST

Ref. No.	Description	R/S Part No.	Mfr's Part No.	Ref. No.	Description	R/S Part No.	Mfr's Part No.	
1	Front Chassis		P-400165	48	AC Outlet	J-6434	P-190098	
2	Side Bracket (L)	HB-7052	P-411271	49	AC Outlet Cover	HB-6377	P-610454	
3	Side Bracket (R)	HB-7053	P-411270	50	8P Speaker Terminal (Screw)	J-4455	P-320086	
4	Rail for Pointer	HB-7054	P-411269	51	4P Speaker Terminal (RCA)	J-4473	P-190100	
5	Lamp Cover	HB-7055	P-411268	52	Fuse Holder (UL)	F-1131	P-260011	
6	Reflector Board	HB-7056	P-411272		Fuse Holder (C.S.A.)		P-260013	
7	Lamp Cover for Meter	HB-7057	P-411288	53	10P Input Terminal	J-4526	P-320095	
8	Fuse Type Lamp	L-0529	P-240038	54	Antenna Terminal	J-4527	P-320190	
9	Lamp Holder	HB-2423	P-260012	55	5P DIN Connector	J-0747	P-190036	
10	Dial Scale	G-0322	P-640171			J-0747	or P-190126	
11	Side Holder (L)	HB-7058	P-411292	56	Ground Terminal	HD-2191	P-420225	
12	Side Holder (R)	HB-7059	P-411291	57	FM Line Antenna Bracket	HB-7066	P-411297	
13	Tuning Shaft Ass'y	D-3238	P-420269	58	Insulator for Line Antenna	HB-6963	P-690214	
14	Dial Pointer Ass'y	D-1232	P-450058	59	AM Antenna Coil	CA-3853	P-110080	
15	Dial Holder	HB-7060	P-411289	60	Antenna Holder	HB-2890	P-410856	
16	Headphone Jack	J-0919	P-190125	61	Electrolytic Capacitor C802, 803 (6800 $\mu$ F/35 V)		P-220031	
17	Headphone Jack Spacer		P-820458	62	Ground Lug Terminal	HB-6878	P-320152	
18	Main Chassis		P-400164	63	Balun Coil	CA-2942	P-110012	
19	Power Transformer Bracket	HB-7061	P-411273	64	Balun Coil P.C.B.	X-4972	P-200244	
20	Reinforced Bracket		P-411334	65	AM/FM Signal Meter	M-0365	P-230065	
21	Sub-pulley Bracket (A)	HB-7062	P-411293	66	LED (Stereo Indicator) (LED801)	L-0835		
22	Sub-pulley Bracket (B)	HB-7063	P-411287	67	Ring for LED	HB-7067	P-610504	
23	Sub-pulley Bracket (D)	HB-7064	P-411313	68	LED Bracket	RB-5993	P-440118	
24	Sub-pulley (L)	D-0385	P-610049	69	Bushing for LED	HB-7068	P-680161	
25	Dial Pulley	D-0396	P-610439	70	Wire Stay (A)	H-3498	P-450006	
26	Dial Spring	RA-5847	P-440014	71	Thermal Protector (TP801)		P-290019	
27	Hook			72	Thermal Protector Bracket	HB-6780	P-411217	
28	Dial Spring			73	Heat Sink for Main Amp.	HH-0248	P-411299	
29	Tuner, IF & MPX Assembled P.C.B.	X7592	U-22025	74	Heat Sink for Rectifier		P-411327	
30	Power Supply Assembled P.C.B.	X-7596	U-17046	75	P.C.B. Bracket	HB-7073	P-410609	
31	PHONO Equalizer Amp. Assembled P.C.B.	X-7593	U-14078	76	Front Panel Ass'y	Z-3825	P-700238	
32	MAIN Amp. Assembled P.C.B.	X-7595	U-16061	77	Dial Window		P-640175	
33	NOISE MUTING Assembled P.C.B.		U-25077	78	Front Dial Window	G-0323	P-640172	
34	SELECTOR Switch	S-1291	P-180250	79	Power Transistor TR611, 612, 613, 614 (2SD315 and 2SB509)			
35	SPEAKER Switch	S-1292	P-180251	80	Soft Tape for Meter		P-680166	
36	Switch Bracket	HB-7065	P-411285	81	Dial Window Holder		P-411372	
37	Switch Joint	HB-1331	P-610091	82	Cushion	HB-7070	P-680158	
38	Switch Shaft	D-3239	P-420270	83	Blind Sheet	HB-7071	P-660160	
39	Switch Bearing	HB-1344	P-610094	84	Push Knob (252)	K-2780	P-650252	
40	Switch Assembled P.C.B.	X-7597	U-23074	85	Push Knob (253)	K-2781	P-650253	
41	TONE CONTROL Assembled P.C.B.	X-7594	U-14079	86	TUNING Knob (250)	K-2782	P-650250	
42	Power Switch	S-7047	P-180044	87	Control Knob (251)	K-2783	P-650251	
43	Power Switch Cover	HB-6875	P-480145	88	Cabinet Ass'y	Z-3828	P-620273	
44	Power Transformer (UL)	TA-0651	P-100463	89	Foot (D)	F-0223	P-610494	
	Power Transformer(C.S.A.)		P-100505	90	Cabinet Spacer		P-480184	
45	Back Panel (UL)	Z-3924	P-411267	91	Sub-pulley (S)		P-610049	
	Back Panel (C.S.A.)		P-411280	<b>HARDWARE</b>				
46	AC Cord Strain Relief	HB-0598	P-480010	Ref. No.	Description	R/S Part No.	Mfr's Part No.	
47	AC Cord	W-1000	P-310001	S1	Bind Tapping Screw 3 x 8 BT-2			



Ref. No.	Description	R/S Part No.	Mfr's Part No.	Ref. No.	Description	R/S Part No.	Mfr's Part No.
S2	Bind Tapping Screw with Waveform Washer Ass'y 3 x 8 BT-2			R2	Rivet YB-429 (Black)		
S3	Screw with Spacer 3 x 9 x 3			R3	Rivet YB-420 (Black)		
S4	Screw with Toothed Lock Washer 3 x 6 P			W1	E type Washer 4 $\phi$		
S5	Tapping Screw with Toothed Lock Washer (Black) 3 x 8 BT-2			W2	Washer 4 W		
S6	Screw 4 x 37 P (Black)			W3	Toothed Lock Washer (Inside) 4 $\phi$		
S7	Bind Tapping Screw 3 x 10 BT-2			W4	Washer 3 W		
S8	Screw with Toothed Lock Washer 3 x 5 P			W5	Washer for Wire Solding 3 $\phi$		
S9	Special Screw (SWRM10)		P-710130	W6	Toothed Lock Washer (Outside) 3 $\phi$		
S10	Wood Screw 3.1 x 13 PW			W7	Polyethylene Washer 0.5 t	HD-8185	P-480172
S11	Screw 4 x 16 P			W8	Square Washer		P-410033
				W9	Nylon Washer 0.3 t		P-480183
R1	Rivet YB-429			SW1	Spring Washer 3SW		
				SW2	Spring Washer 4SW		
				N1	Nut 4N		
				N2	Special Nut with Cover		

## 19. IC INTERNAL DIAGRAM

(NJM-4558)

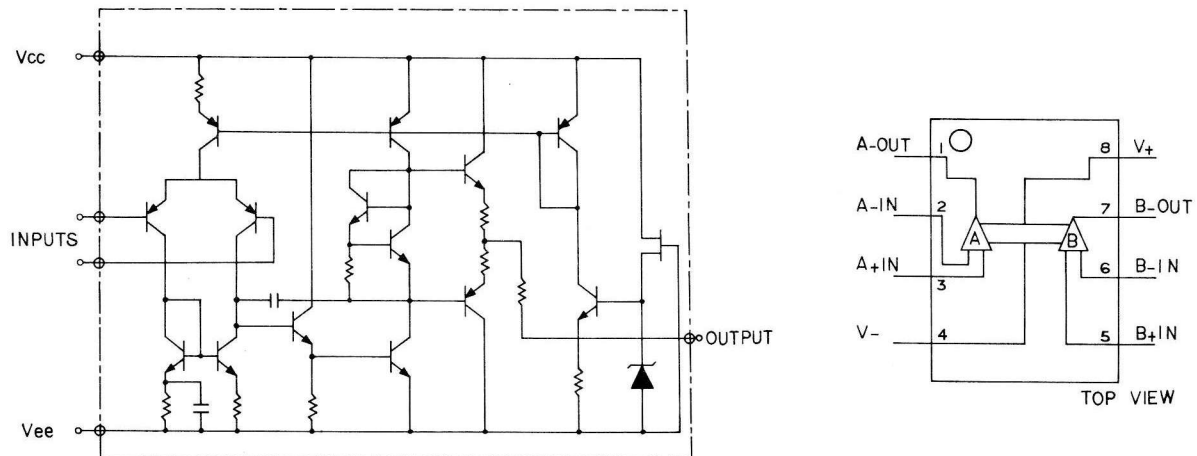

(LA-3350)

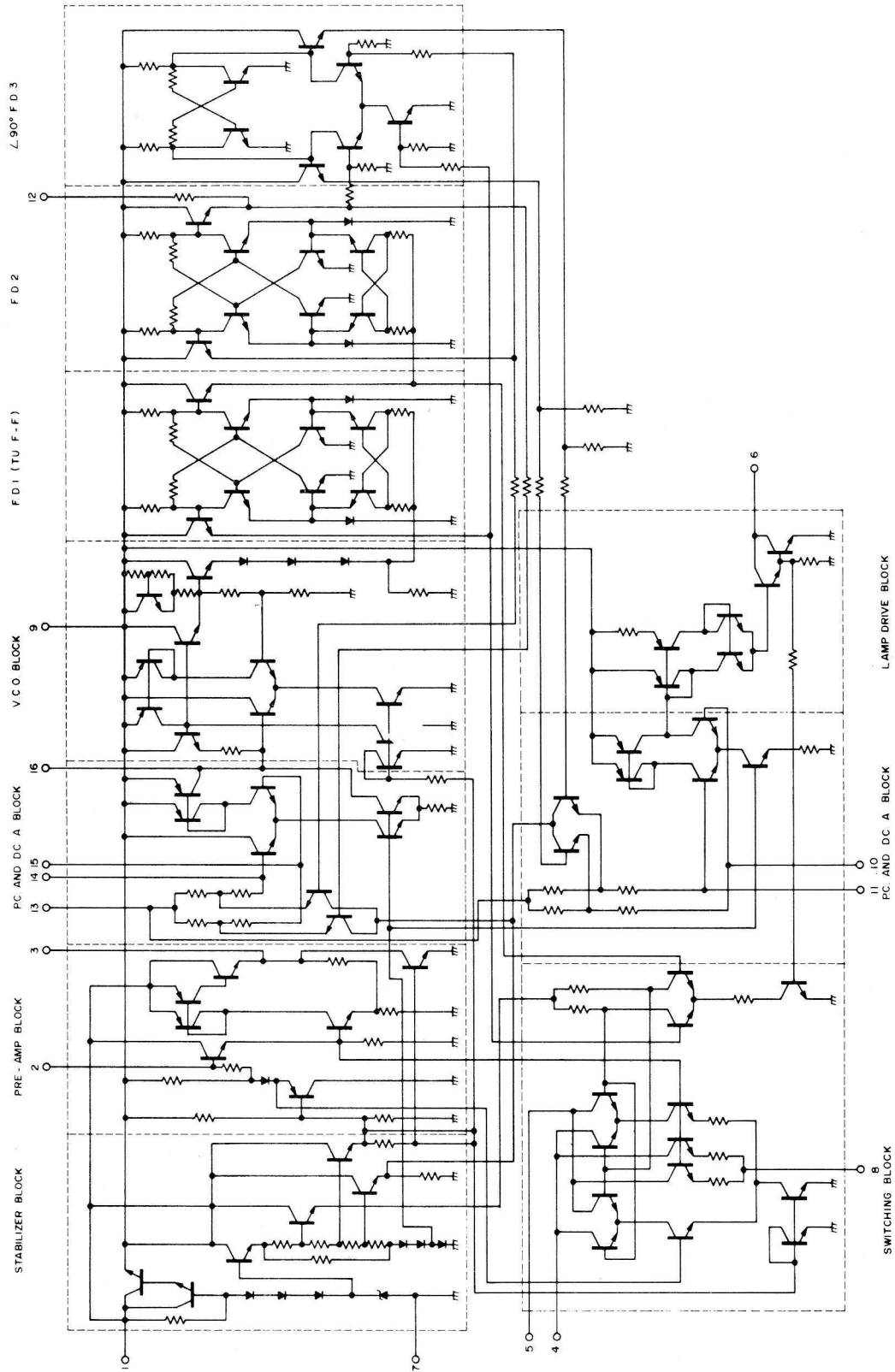

(HA-11211)

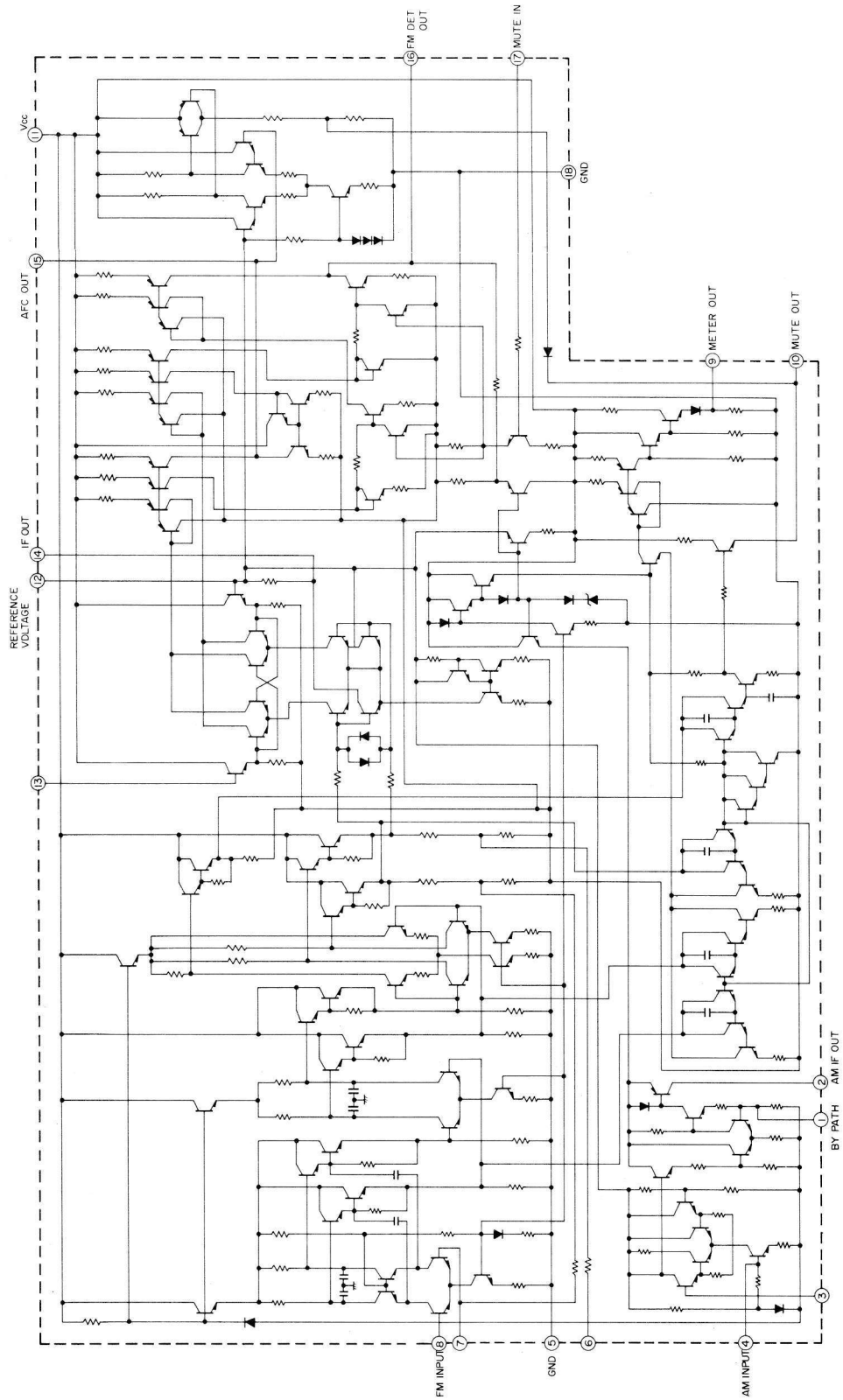

# 20. SCHEMATIC DIAGRAM

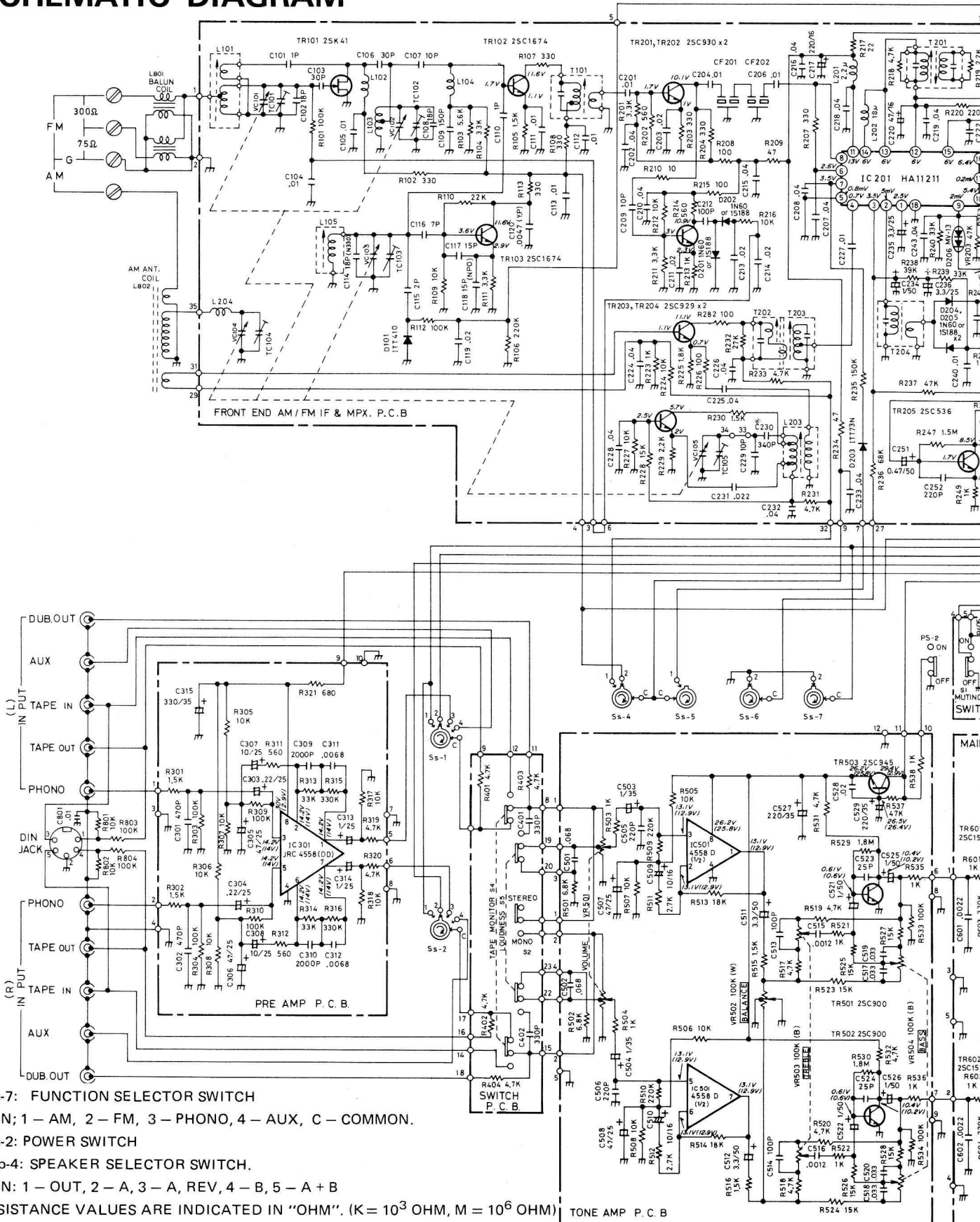

**NOTE:**

- (1) Ss-1 – Ss-7: FUNCTION SELECTOR SWITCH POSITION; 1 – AM, 2 – FM, 3 – PHONO, 4 – AUX, C – COMMON.
- (2) Ps-1 – Ps-2: POWER SWITCH
- (3) Sp-1 – Sp-4: SPEAKER SELECTOR SWITCH. POSITION: 1 – OUT, 2 – A, 3 – A, REV, 4 – B, 5 – A + B
- (4) ALL RESISTANCE VALUES ARE INDICATED IN "OHM". (K = 10<sup>3</sup> OHM, M = 10<sup>6</sup> OHM)
- (5) ALL CAPACITANCE VALUES ARE INDICATED IN "μF". (P = 10<sup>-6</sup> μF)
- (6) ( ) VALUES IN MAIN AMP STAGE ARE USED FOR C.S.A. MODELS ONLY.
- (7) ALL VOLTAGES ARE MEASURED TO CHASSIS GROUND WITH A VOLTMETER (10 K OHM/V).
- (8) VOLTAGES ARE MEASURED UNDER TWO CONDITIONS: WITH NO INPUT AND AT 22 W (1 kHz) OUTPUT POWER (INSIDE PARENTHESIS).



# 21. EXPLODED VIEW

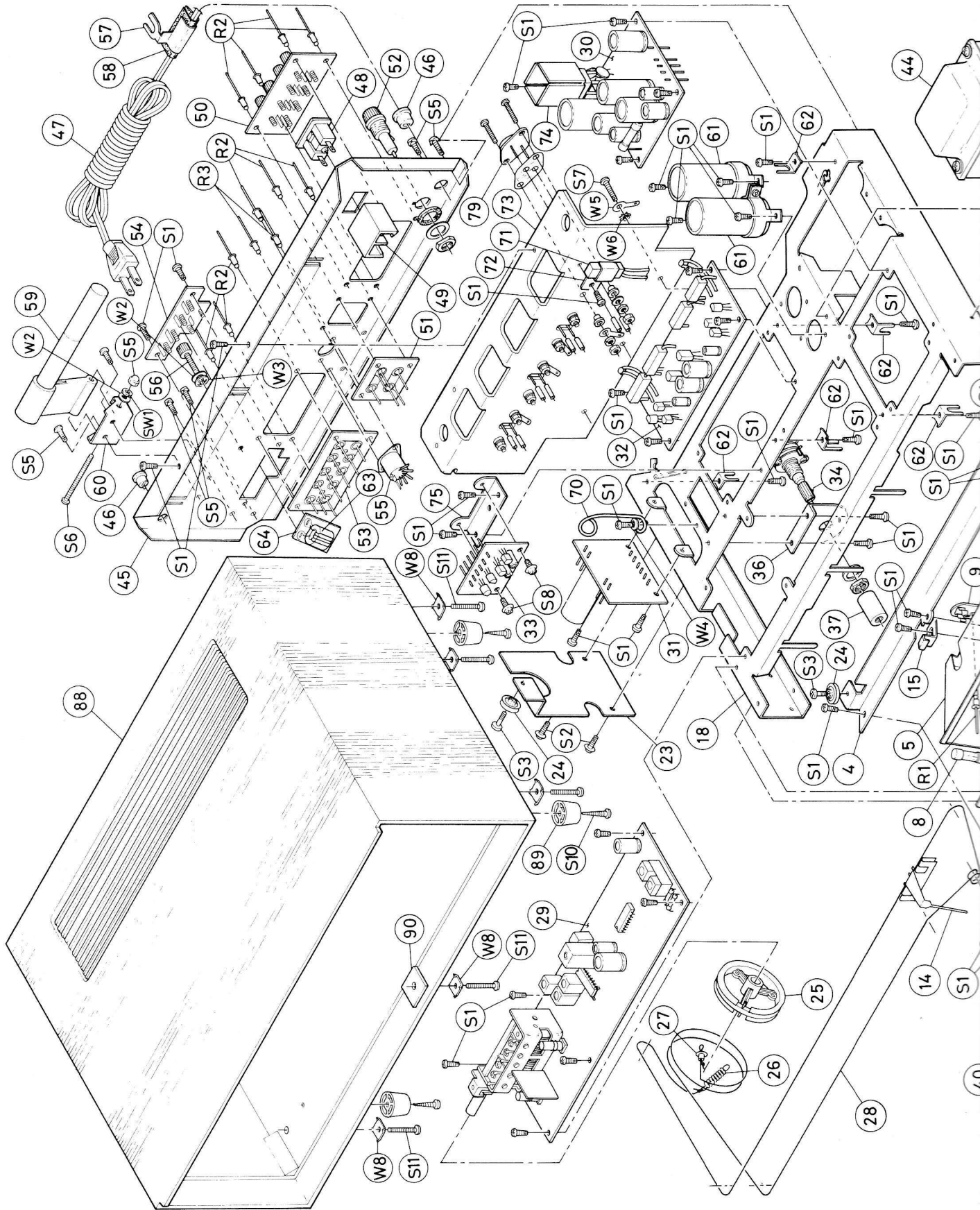

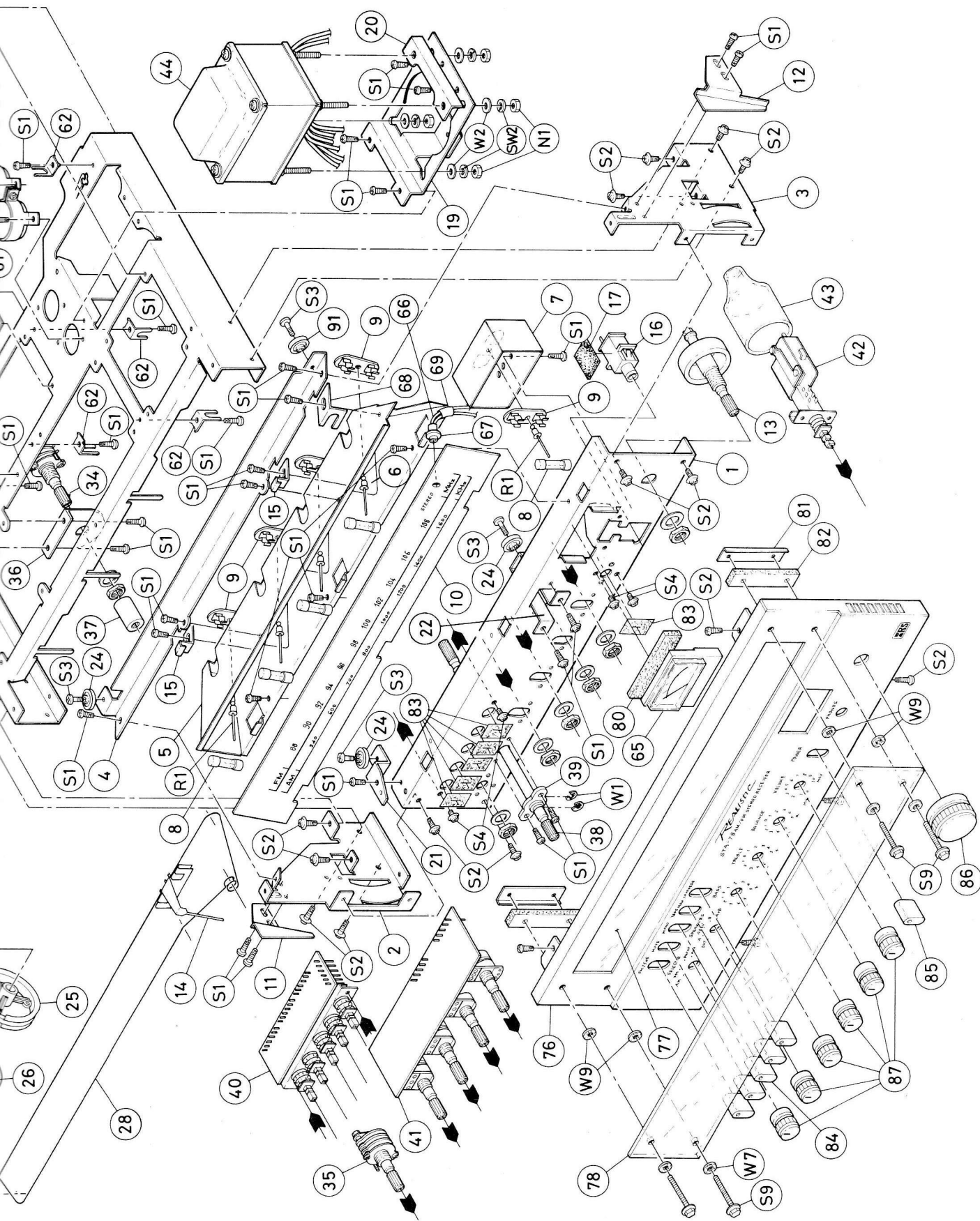

RADIO SHACK  A DIVISION OF TANDY CORPORATION

U.S.A.: FORT WORTH, TEXAS 76102  
CANADA: BARRIE, ONTARIO L4M 4W5

---

**TANDY CORPORATION**

AUSTRALIA

---

280-316 VICTORIA ROAD  
RYDALMERE, N.S.W. 2116

BELGIUM

---

PARC INDUSTRIEL DE NANINNE  
5140 NANINNE

U. K.

---

BILSTON ROAD, WEDNESBURY  
WEST MIDLANDS WS10 7JN