

REVISION RECORD			
LTR	ECO NO:	DATE	BY
H	26B1	2/17/99	GL

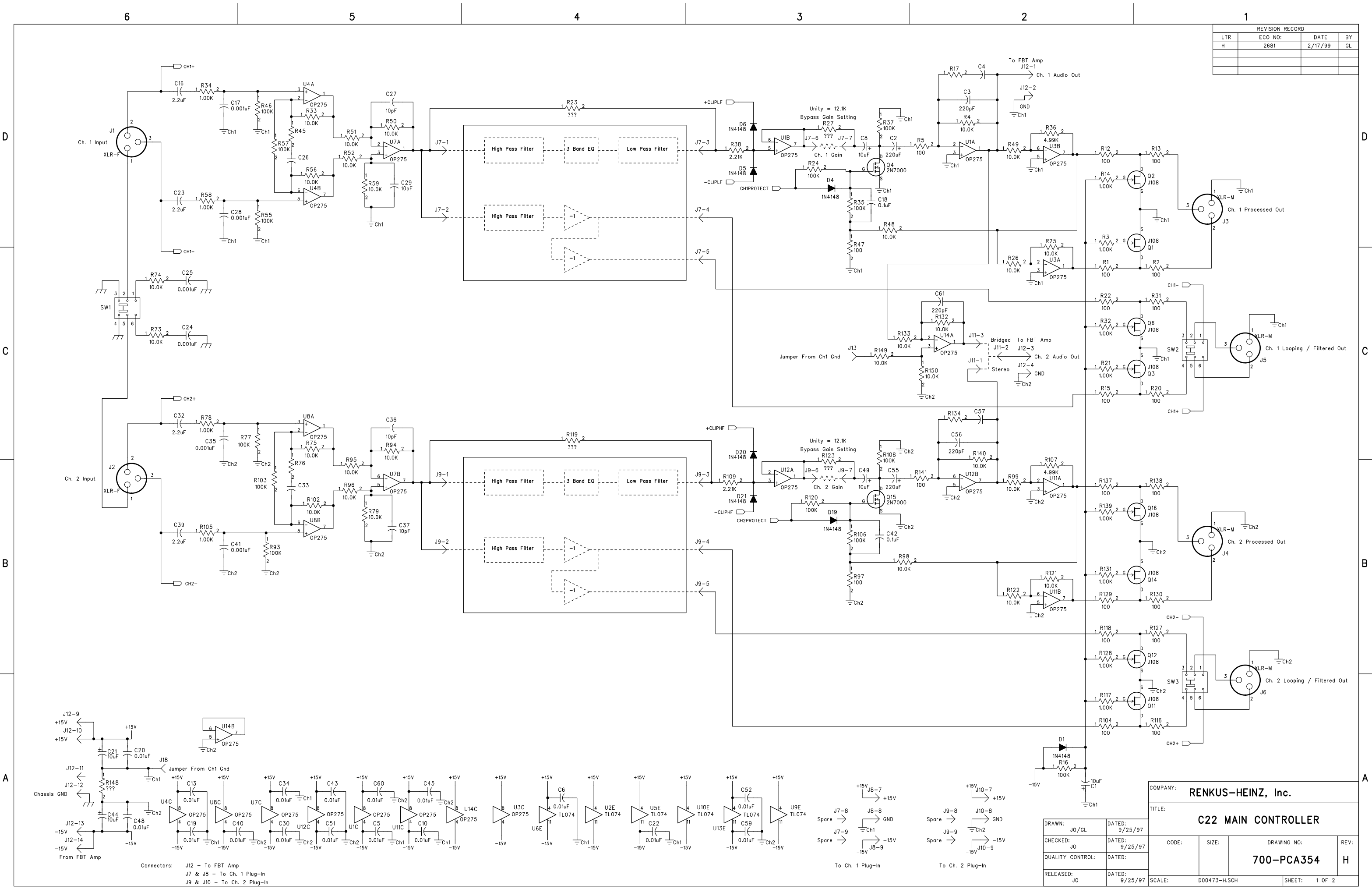

COMPANY: <b>RENKUS-HEINZ, Inc.</b>			
TITLE: <b>C22 MAIN CONTROLLER</b>			
DRAWN: JO/GL	DATED: 9/25/97	CODE:	REV: H
CHECKED: JO	DATED: 9/25/97	SIZE:	DRAWING NO: 700-PCA354
QUALITY CONTROL:	DATED:	SCALE: D00473-H.SCH	SHEET: 1 OF 2
RELEASED: JO	DATED: 9/25/97		

Connectors: J12 - To FBT Amp  
 J7 & J8 - To Ch. 1 Plug-In  
 J9 & J10 - To Ch. 2 Plug-In

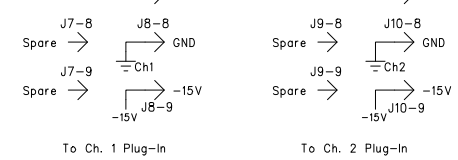

REVISION RECORD			
LTR	ECO NO:	DATE	BY
H	2681	2/17/99	GL

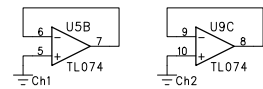
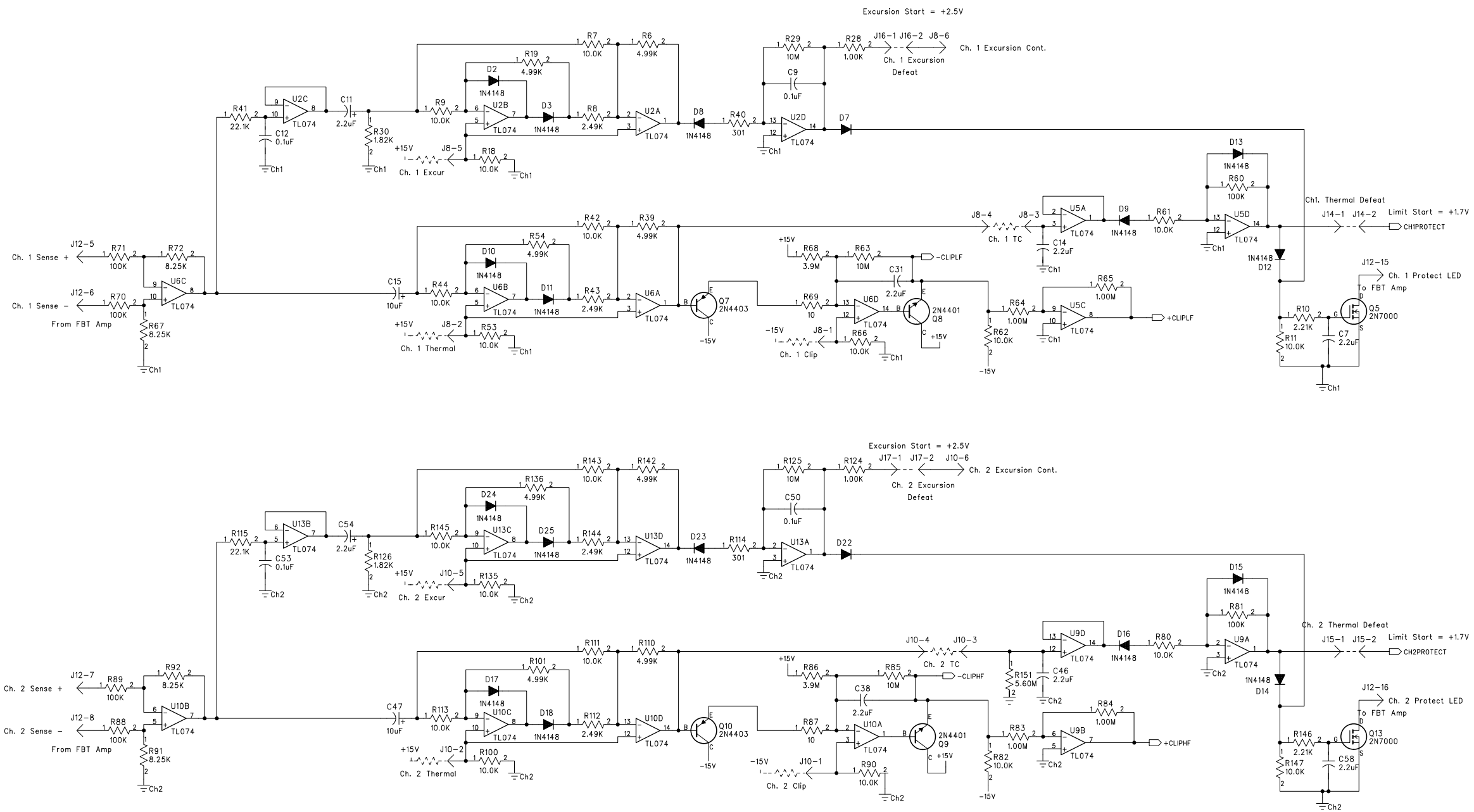

COMPANY: <b>RENKUS-HEINZ, Inc.</b>			
TITLE: <b>C22 MAIN CONTROLLER</b>			
DRAWN: JO/GL	DATED: 9/25/97	CODE:	REV: H
CHECKED: JO	DATED: 9/25/97	SIZE:	DRAWING NO: <b>700-PCA354</b>
QUALITY CONTROL:	DATED:	SCALE: D00473-H.SCH	SHEET: 2 OF 2
RELEASED: JO	DATED: 9/25/97		

## C22 Plug-In Module Switch Settings

Speaker Model	Amplifier Mode	Plug-In PCA #	HP Filter (SW1)	LP Filter (SW2)	Limit (SW3)
TRC61	Stereo	420	High	Low	Low
TRC81/9	Stereo	420	High	High	Low
TRC81/12	Stereo	420	High	High	Low
TRC82/9	Stereo	420	High	High	Medium
TRC82/12	Stereo	420	High	High	Medium
TRC121/9	Stereo	420	Low	High	High
TRC121/12	Stereo	420	Low	High	High
TRC151/6	Stereo	420	Low	High	High
TRC151/9	Stereo	420	Low	High	High
TRC151D/6	Stereo	420	Low	High	High
TRC151D/9	Stereo	420	Low	High	High
TRC152D/6	Stereo	420	Low	High	High
TRC152D/9	Stereo	420	Low	High	High
All Subs	Bridged	489	Low	High	Low
BPS12-1	Stereo	489	Low	High	High
BPS12-2	Stereo	489	Low	High	High
BPS15-1	Stereo	489	Low	High	High
BPS15-2	Stereo	489	Low	High	High
C-2SUB	Stereo	489	Low	High	Medium
DRS18-1B	Stereo	489	Low	High	High
LR-2A	Stereo	489	Low	High	High
SR-61	Stereo	533	High	High	Low
SR-62H	Stereo	533	High	High	Low
SR-81/9	Stereo	533	High	High	Med
SR-81/12	Stereo	533	High	High	Med
SR-82/9	Stereo	533	High	High	Med
SR-82/12	Stereo	533	High	High	Med
SR-5/6	Stereo	533	Low	High	High
SR-5/9	Stereo	533	Low	High	High
CDT350-4	Stereo	485	Low	High	Med
CDT350-6	Stereo	485	Low	High	Med
CDT350-9	Stereo	485	Low	High	Med
CDT500-44	Stereo	485	High	High	Med
CDT500-64	Stereo	485	High	High	Med
CDT500-66	Stereo	485	High	High	Med
CDT500-94	Stereo	485	High	High	Med