

Up-date of CD-Player A727 when using the PARALELL CONTROLLER 1.630.900.00

Before putting in operation please pay attention to the following flow chart:

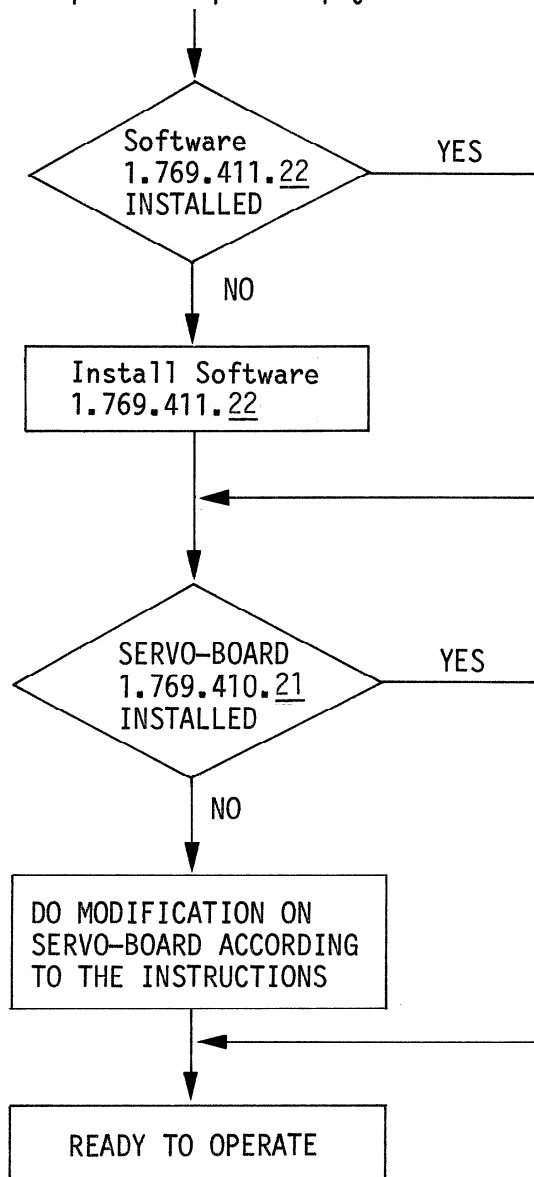

Instructions for Hardware Modification on SERVO board 1.769.410.20

1. Remove the SERVO-BOARD of the A727 carefully. Therefore, disconnect the following cable connections:

SERVO-BOARD ———▶ DECODER-BOARD  
SERVO-BOARD ———▶ CD-DRIVE  
SERVO-BOARD ———▶ DRAWER-MOTOR  
SERVO-BOARD ———▶ KEYBOARD + DISPLAY (3)

2. Make the modifications according to the drawings.

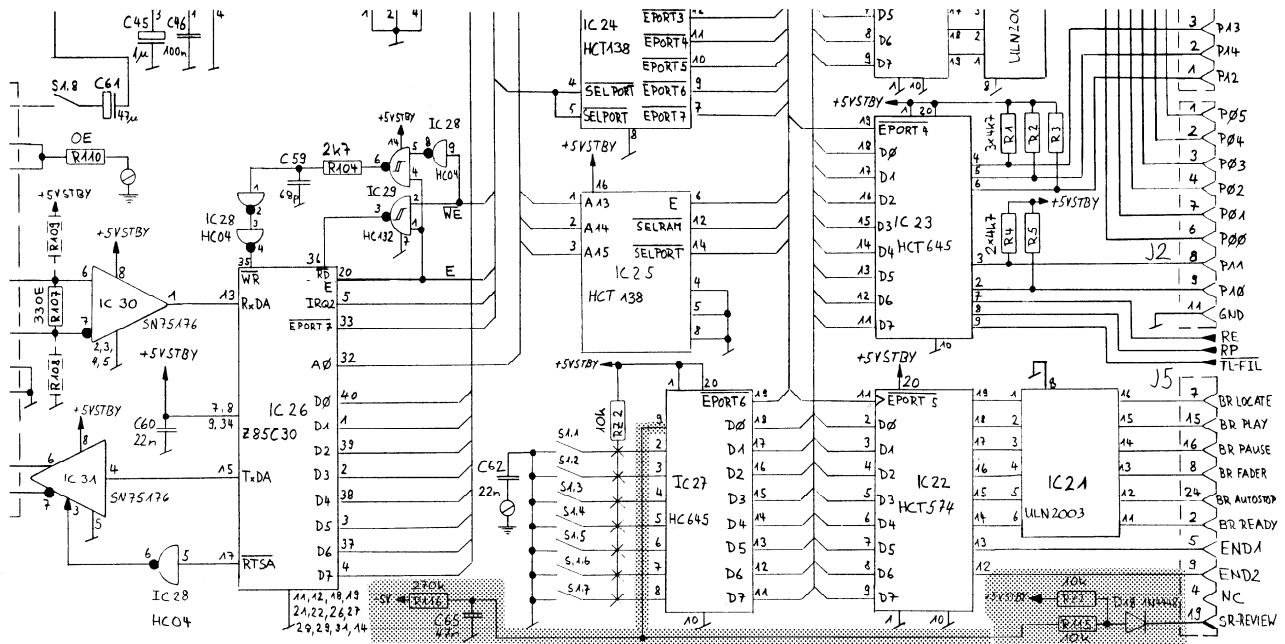

SERVO BOARD A727 1.769.410.20 (BOTTOM VIEW)

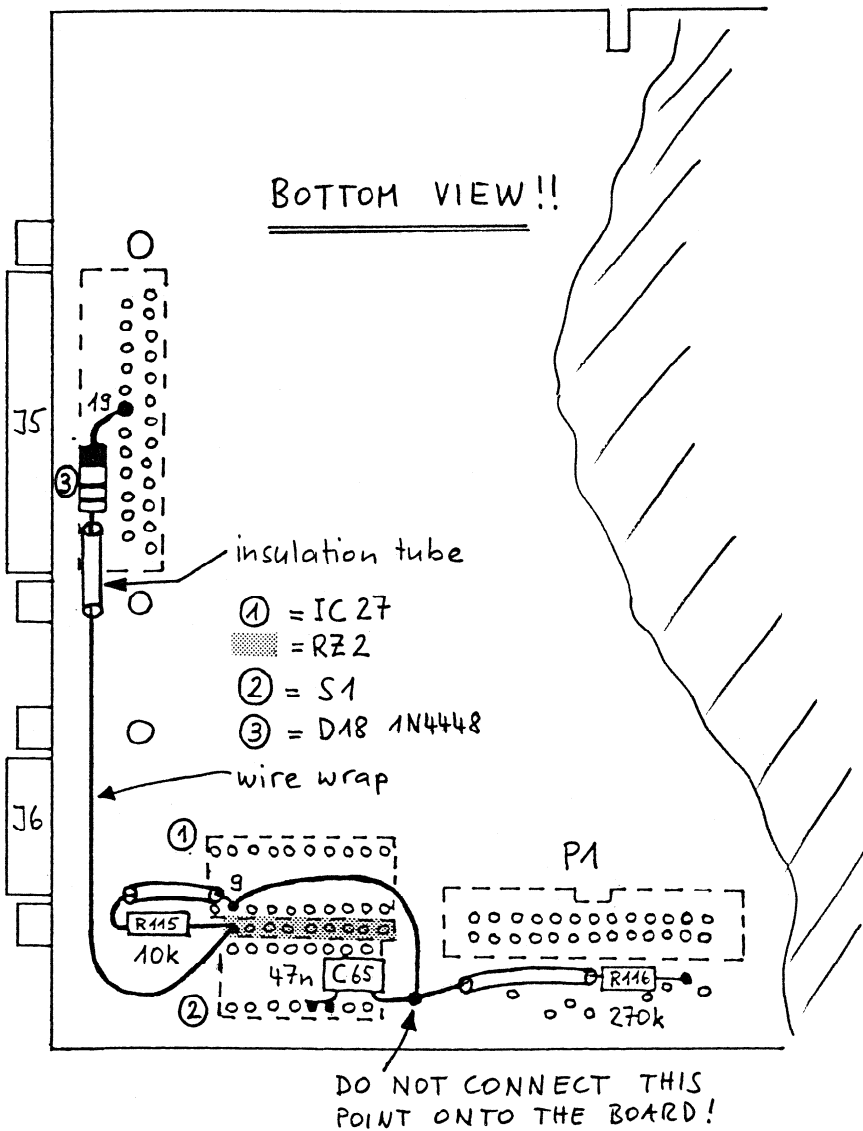

Beilageblatt zum PARALLEL CONTROLLER 1.630.900.00

Vor Inbetriebnahme der Fernsteuerung zusammen mit dem A727 muss je nach Seriennummer des A727 folgendes beachtet werden:

Enclosure to the PARALLEL CONTROLLER 1.630.900.00

Before putting the remote controller with the A727 in operation please check the following points depending on the serial number of your A727:

SERIENUMMER/SERIAL NUMBER A727	Massnahme / Action
1001 .... 1972	A727 zur Modifikation an die nächste Servicestelle weiterleiten. ----- Send A727 for modification to the next service office
1973 .... 2700	<ul style="list-style-type: none"> <li>- Fernsteuerung anschliessen</li> <li>- Falls das Display der Fernsteuerung nicht funktioniert EPROM mit der Bestellnummer 21.769.411.22 nachbestellen und gemäss Zeichnung auf der Rückseite auf dem Servo-Board ersetzen.</li> <li>-----</li> <li>- Connect Remote Controller with the A727</li> <li>- If the display of the remote unit does not operate please order new EPROM 21.769.411.22 and replace it on the Servo-Board according to the drawing on reverse.</li> </ul>
2701 ....	Fernsteuerung kann direkt angeschlossen werden. ----- Connect Remote Controller with the A727.

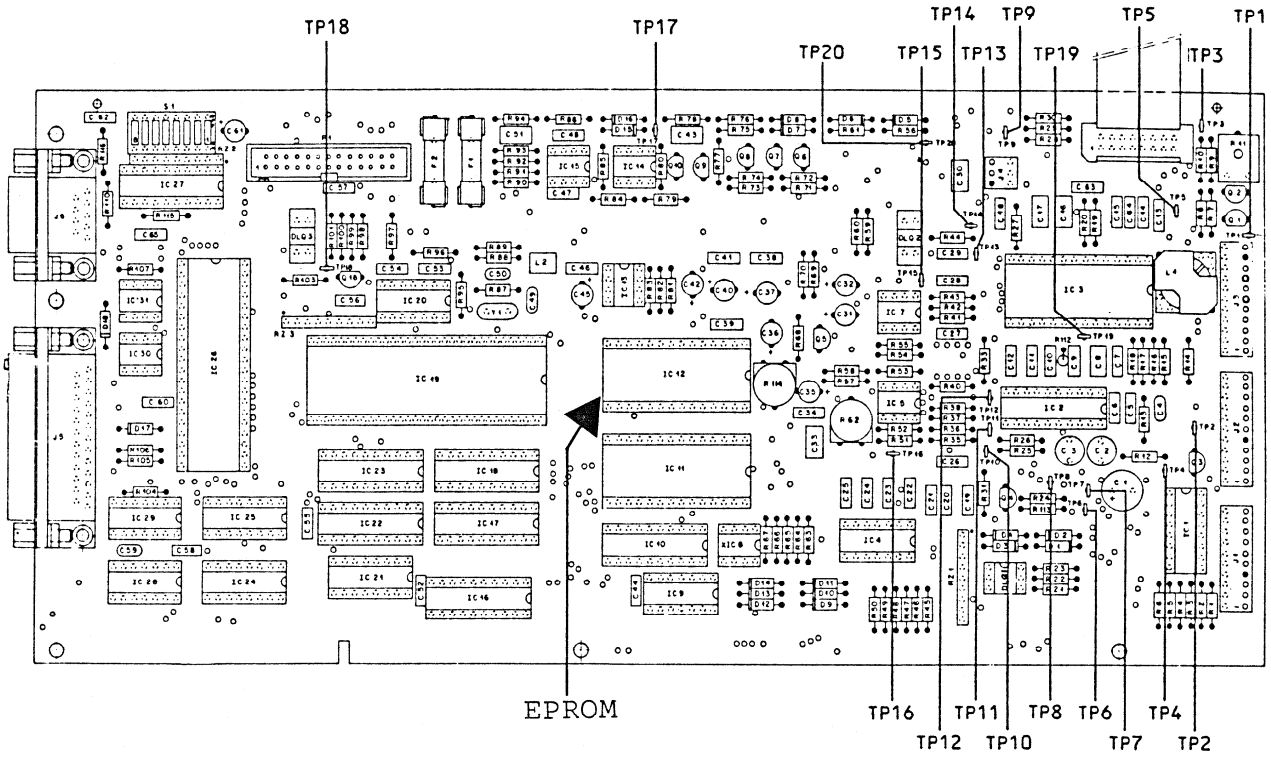

A727 CD-PLAYER

Enclosure to Software versions  
1.769.411.22 and 1.769.411.23

Both software versions contain especially user specific improvements and are only necessary for the following applications:

1. Operation of A727 with PARALLEL CONTROLLER 1.630.900.00 requires software 1.769.411.22 or 1.769.411.23.
2. Operation of A727 via serial remote port (RS 422) requires software 1.769.411.23.

The following list contains the most important improvements which are valid for both versions:

- Date of software release (e.g. 0888 = 8th week, year 88) and version (22) are displayed as soon as the mains connector is plugged in and one of the drive buttons is pressed.
- Improved cueing (see manual section 1.5.13, page 1/7).
- EOM function (end of modulation) has been implemented i.e. if AUTO-STOP-mode is activated then the word PAUSE appears in the display and on the remote control in a flashing mode 15 seconds before the modulation of the played track ends.
- Operation in AUTO-CUE mode effects the starting point to be shifted 3 frames forward to obtain a soft modulation start.
- Improved resolution of index scan ( $\pm 1$  frame).
- With regard to the CD-single the acceleration time of the disc motor has been decreased.

For replacement of the EPROM please remove the top cover. Replace IC 12 on the servo board 1.769.410 (IC with label). (siehe Rückseite)

SI 119/88 10.85.6050

A727 CD-SPIELER

Beiblatt zu den SOFTWAREVERSIONEN  
1.769.411.22 und 1.769.411.23

Diese S/W Versionen beinhalten im Vergleich zur vorigen Version 1.769.411.20 vor allem anwenderspezifische Neuerungen und sind deshalb nur in folgenden Fällen zwingend:

1. Betrieb des A727 mit PARALLEL CONTROLLER 1.630.900.00 erfordert Software 1.769.411.22 oder 1.769.411.23.
2. Betrieb des A727 via serielle Schnittstelle RS 422 erfordert Software 1.769.411.23.

Nachfolgend werden die wichtigsten Neuerungen, welche beide Versionen haben, aufgelistet:

- Entstehungsdatum der Software (z.B. 0888 = 8. Woche, Jahr 88) und Version (22) werden im Display angezeigt, sobald der Netzstecker eingesteckt und eine Laufwerktaaste betätigt wird.
- Verbessertes Cueing (siehe Manual 1.5.13, Seite 1/7).
- EOM-Funktion (end of modulation) ist implementiert d.h. falls das Gerät im AUTOSTOP-Modus läuft, beginnt 15 Sekunden vor Ende der laufenden Track die PAUSE-Anzeige zu blinken.
- Bei der AUTO-CUE Funktion wird der Startpunkt um 3 Frames (40 ms) nach vorne verschoben, um einen weichen Modulationsanschnitt zu gewährleisten.
- Verbesserte Indexsuchlaufgenauigkeit ( $\pm 1$  Frame).
- In Hinsicht auf die CD-Single wurde die Beschleunigungszeit der CD verkleinert.

Beim Wechseln des EPROM oberes Deckblech entfernen und IC 12 auf Servo-board 1.769.410 ersetzen (IC mit Etikette). (see reverse)

(RR/04.88)

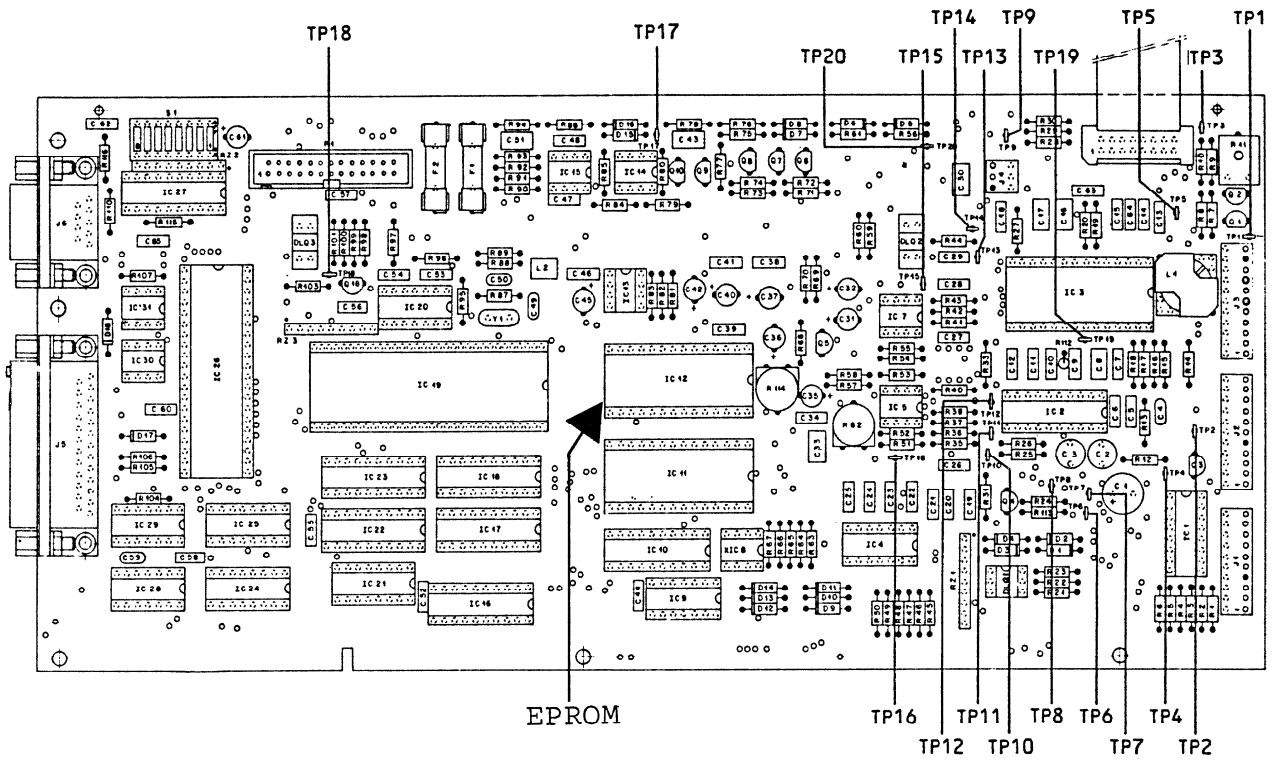

# STUDER

PROFESSIONAL AUDIO EQUIPMENT

## Service Information

Ausbau der LASER-Einheit

Disassembly of the LASER-pickup

SI 123/89

Ausbau der LASER-Einheit

- Laufwerk ausbauen
- Flexprint, welcher zur Laser-Diode führt, auslöten ① (Vorsicht: Flexprint nicht überhitzen)
- Zweiten Flexprint aus dem Sockel ziehen ② .
- Laserarm in Position gemäss Bild bringen und mit dem Daumen fixieren.
- Mit Gabelschlüssel Grösse 12 an der abgeflachten Stelle ③ gemäss Bild ansetzen und im Gegenurzeigersinn drehen, bis sich die Lasereinheit löst.

Einbau der LASER-Einheit

- Lasereinheit ins Loch der Optikeinheit legen und mit Gabelschlüssel Grösse 12 bis zum Anschlag anziehen.
- Kurzschlussbügel an den Laserkontakten entfernen und Flexprint anlöten ① (Vorsicht: Flexprint nicht überhitzen).
- Zweiten Flexprint in den Sockel stecken ② .
- Laufwerk wieder ins Gerät einbauen.
- Laserstrom je nach Gerätetyp (A725, A727) gemäss beiliegendem Blatt einstellen.

Disassembly of the LASER-pickup

- Remove the CD-play mechanism
- Unsolder the flexprint which is connected with the laser-diode ① (Remark: Do not overheat the flexprint).
- Pull the other flexprint out of the socket ② .
- Put the laserarm in the position according to the figure and hold it in place with your thumb.
- Put an open-end wrench (size 12) on the flattened area ③ and turn the laser-unit counterclockwise until it is loosened.

Replacement of the LASER-pick-up

- Place the laser-pick-up into the hole of the optical unit and tighten it clockwise with an open-end wrench (size 12) until a stop is felt (locking).
- Remove the short-circuit connector from the laser contacts and solder the flexprint ① (Remark: Do not overheat the flexprint).
- Plug the other flexprint into the socket ② .
- Install the CD-play mechanism
- Adjust the laser current depending on the type of device (A725, A727) according to the enclosed sheet.

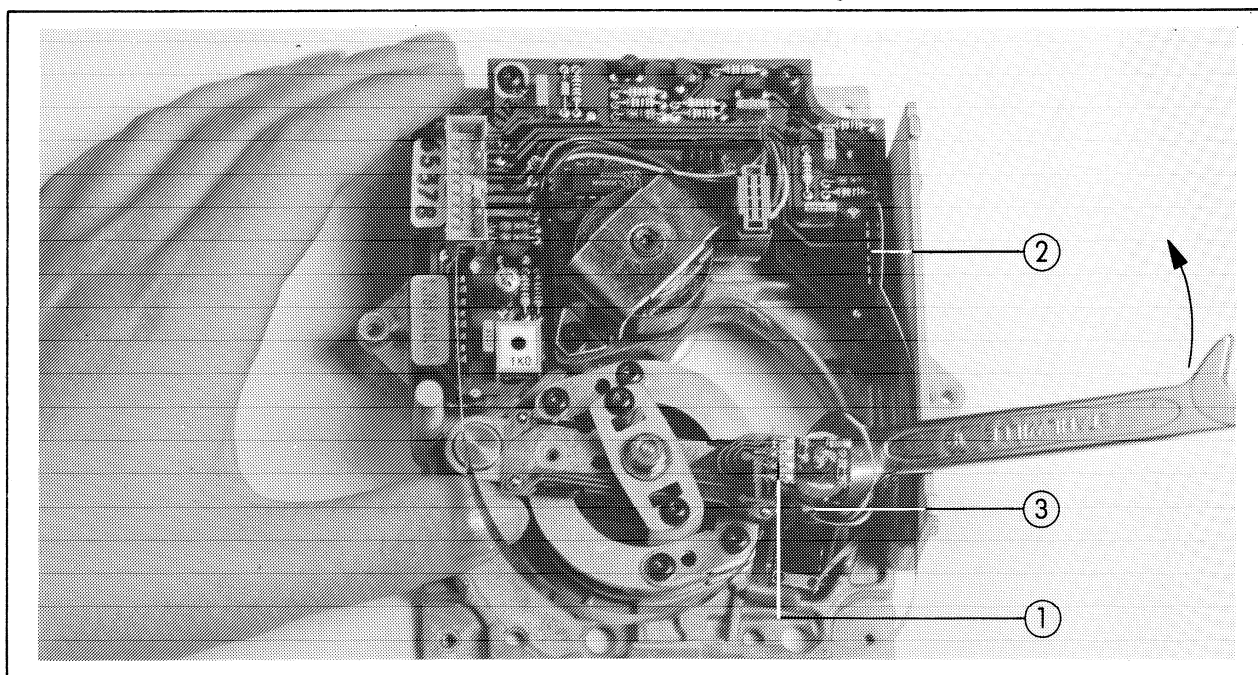



# A725

## 4.2.4 Laserstrom einstellen

- Gerät ausschalten, Servo 2- Print 1.769.330 ausbauen und über Serviceprint (aus Set 1.769.487) wieder einstecken.
- Linke Spannfeder für Gehäusedeckel mit Kreuzschlitzschraubenzieher lösen und etwas nach rechts drehen um Kurzschluss mit den Kontakten von Servo- 2 PCB zu verhindern (siehe Fig. 4.14).
- Abdeckung des IR- Empfängers auf Servo-2 PCB 1.769.330 mit einem Stück Papier gegen den benachbarten Print isolieren.
- Gerät an der Tischkante aufstellen, damit die ausgefahrene Schublade von unten zugänglich ist.
- DC- Voltmeter ( Bereich 1,5V DC) an R63 auf Servo 2- PCB anschliessen (siehe 4.15, Pfeil).
- Gerät einschalten und mit PLAY/NEXT starten.
- Mit Trimpotentiometer LASER OUTPUT (auf Laufwerk 1.769.100.36, Fig. 4.16) die Spannung an R63 auf  $565mV \pm 75mV$  einstellen.

Dieser Abgleich sollte nur vorgenommen werden, wenn die gemessene Spannung ausserhalb der angegebenen Toleranz liegt.

### Achtung:

Spannungswerte über  $640mV$  verkürzen die Lebensdauer des Laserabtasters.

- Gerät ausschalten und Servo 2 Print wieder einbauen.

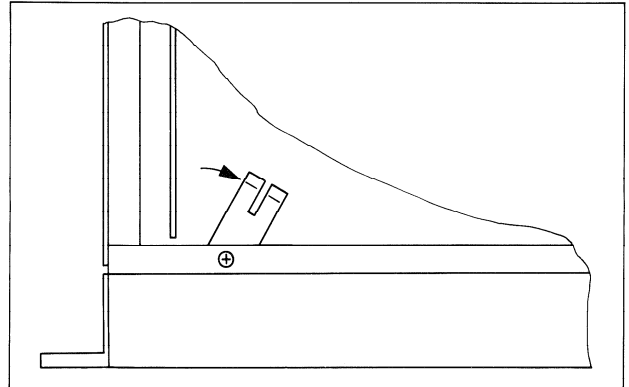

Fig. 4.14

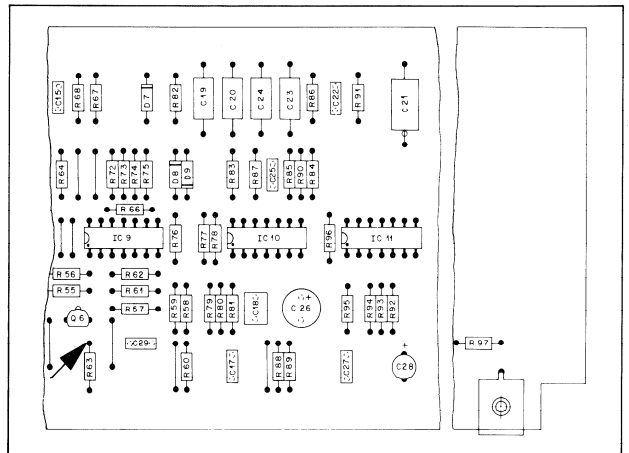

Fig. 4.15

## 4.2.4 Adjusting the Laser current

- Switch CD player off, remove SERVO 2 PCB 1.769.330 and reinsert it via the service PCB (from set 1.769.487).
- Unfasten the left-hand tensioning spring of the housing cover by means of a screwdriver for recessed-head screws and turn it somewhat to the right to prevent short circuit with the contacts of the SERVO 2 PCB (see Fig. 4.14).
- Insulate the cover of the IR receiver on SERVO 2 PCB 1.769.330 against the adjacent PCB by means of a piece of paper.
- Place the CD player near the edge of the work bench so that the drawer becomes accessible from the bottom.
- Connect DC voltmeter (range 1.5 VDC) to R63 on SERVO 2 PCB (see arrow in Fig. 4.15).
- Switch CD player on and start it with PLAY/NEXT.
- Adjust the voltage on R63 to  $565mV \pm 75mV$  with the aid of trimmer potentiometer LASER OUTPUT (on player mechanism 1.769.100.36, Fig. 4.16).

This adjustment should only be made if the measured voltage is outside the specified tolerance range.

### CAUTION:

Voltages above  $640mV$  shorten the life of the laser pickup.

- Switch CD player off and reinstall SERVO 2 PCB.

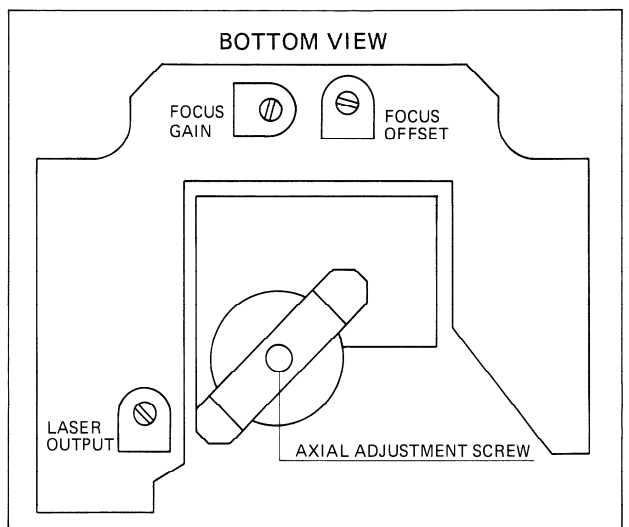

Fig. 4.16

# A727

## 4.3.3 Laserstrom einstellen

-> Fig. 4.8 / Fig. 4.10

- Oberes Deckblech entfernen (Abschnitt 2.2.1).
- Die Laufwerk-Abdeckung entfernen (Abschnitt 2.2.2).
- Das Kathodenstrahl-Oszilloskop an TP3 (HF\*), Masse an TP19 auf SERVO BOARD A727 1.769.410 anschliessen.
- Das Gerät so aufstellen, dass der CD-DRIVE BOARD zugänglich bleibt.
- Test-CD Nr.3 (TRACK 1) abspielen.
- Mit dem Trimpotentiometer R13 auf dem CD-DRIVE BOARD 1.769.116 eine Spannung von 550 mVpp  $\pm$ 50 mV einstellen.

## 4.3.3 Adjusting the Laser current

-> Fig. 4.8 / Fig. 4.10

- Remove the top cover (Section 2.2.1).
- Remove the cover of the CD play mechanism cover (Section 2.2.2).
- Connect the cathode ray oscilloscope to TP3 (RF\*), and the ground lead to TP19 on the SERVO BOARD A727 1.769.410.
- Position the unit in such a way that the CD-DRIVE BOARD remains accessible.
- Play test CD No. 3 (TRACK 1).
- With the trimmer potentiometer R13 on the CD-DRIVE BOARD 1.769.116 adjust to a voltage of 550 mVpp  $\pm$ 50 mV.

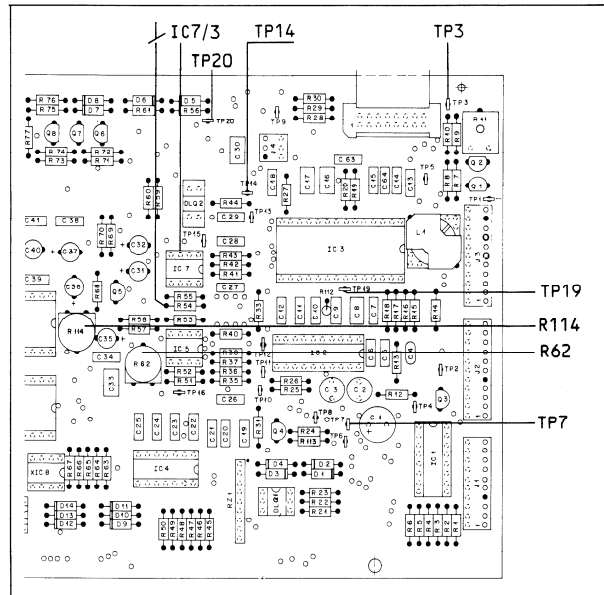

Fig. 4.8

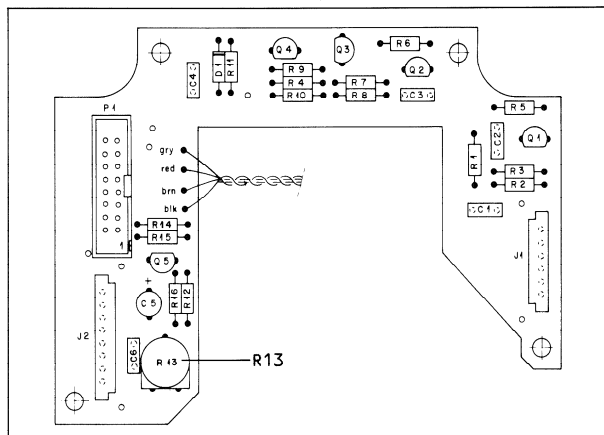

Fig. 4.10

# STUDER

PROFESSIONAL AUDIO EQUIPMENT

## Service Information

A727 Hard- und Software Modifikationskit  
(Nachrüstsatz 20.100.727.00)

A727 Hard- and Software Modification kit  
(Up-date kit 20.100.727.00)

SI 135/89      d/e                      10.85.7110

Inhaltsverzeichnis:

1. Anwendung
2. Inhalt des Umrüstsatzes
3. Software 1.769.411.24
4. Empfohlene Hardware  
Änderungen
- 4.1 SERVO BOARD 1.769.410.21
- 4.2 DECODER BOARD 1.769.430.81

Table of contents

1. Application
2. Contents of the modification  
kit
3. Software 1.769.411.24
4. Recommended hardware  
changes
- 4.1 SERVO BOARD 1.769.410.21
- 4.2 DECODER BOARD 1.769.430.81

## 1. Anwendung

Dieser Update wird für alle A727 empfohlen. Die Aenderungen verbessern die Betriebssicherheit bezüglich folgender Gesichtspunkte:

- Zeitweise auftretende Fehlanzeigen im Display kommen nicht mehr vor
- Verbesserte Akzeptanz von bombierten CDs
- Erhöhte Zuverlässigkeit der Schalttransistoren für die Speisungen +12V und -15V.

## 2. Inhalt des Umrüstsatzes

Bestellnummer für den Nachrüstsatz: 20.100.727.00

1 EPROM (Software)	1.769.411.24
1 Widerstand 2.2 $\Omega$	57.11.3229
1 Kondensator 100pF	59.34.4101
1 Transistor ZTX 751S	50.03.0352
1 Transistor ZTX 651S	50.03.0523
2 Steckkontakte	53.03.0228
1 Indexschild -24	1.101.002.24
1 Indexschild -82	1.010.082.43
1 Hardwareschild	
Index -21	1.101.001.21
1 Service Information	10.85.7110

Widerstandsdekade >100k $\Omega$

## 1. Application

This update is recommended for all A727. Increased operating reliability is obtained relating the aspects below:

- Intermittent erroneous indications on the display have been eliminated
- Improved acceptance of dished CDs
- Improved reliability of the switching transistors for the supply voltages +12V and -15V.

## 2. Contents of the modification kit

Order number for the modification kit: 20.100.727.00

1 EPROM (Software)	1.769.411.24
1 resistor 2.2 $\Omega$	57.11.3229
1 capacitor 100pF	59.34.4101
1 transistor ZTX 751S	50.03.0352
1 transistor ZTX 651S	50.03.0523
2 contact pins	53.03.0228
1 sticker -24	1.101.002.24
1 sticker -82	1.010.082.43
1 sticker hardware	
-21	1.101.001.21
1 service information	10.85.7110

Resistance decade box >100k $\Omega$

### 3. Software 1.769.411.24

Diese Software ersetzt alle vorgängigen Versionen. Zeitweise auftretende Fehlanzeigen im Display kommen nicht mehr vor. Die Software enthält kein ES-Bus Protokoll dh. für den Betrieb mit dem A729 Controller ist sie nicht vorbereitet. Eine dafür ausgelegte Version wird beim Erscheinen des A729 Controllers zur Verfügung stehen. IC12 auf dem SERVO BOARD 1.769.410.21 wird durch das EPROM 1.769.411.24 ersetzt. (Siehe auch 4.1)

### 4. Empfohlene Hardware Aenderungen

#### 4.1 SERVO BOARD 1.769.410.21

Eine Vergrößerung des Regelbereiches für die Focuslinse wird durch die Aenderung von R29 und C28 auf dem SERVO BOARD erreicht. Somit akzeptiert der A727 leicht konvexe resp. konkave CDs in grösserem Ausmass.

#### Modifikation:

- R29 4.70hm ändert auf 2.20hm (57.11.3229)
- C28 10uF ändert auf 100pF (59.34.4101)
- IC12 (EPROM) ändert auf 1.769.411.24
- SERVO BOARD 1.769.410.21 ändert auf 1.769.410.24

(Indexschilder .24 und hardware -21 anbringen)

### 3. Software 1.769.411.24

This software replaces all previous versions. Intermittent erroneous indications on the display have been eliminated. There is no ES-bus protocol implemented i.e. this software is not prepared for operation with the A729 controller. A version for this application will be available with the introduction of the A729 controller. IC12 on SERVO BOARD 1.769.410.21 is replaced by the EPROM 1.769.411.24. (See also 4.1)

### 4. Recommended hardware changes

#### 4.1 SERVO BOARD 1.769.410.21

Increase of the control range for the focus lens can be achieved by changing R29 and C28 on the SERVO BOARD. This causes the A727 to accept even slightly dished CDs.

#### Modification:

- R29 4.70hm changes to 2.20hm (57.11.3229)
- C28 10uF changes to 100pF (59.34.4101)
- IC12 (EPROM) changes to 1.769.411.24
- SERVO BOARD 1.769.410.21 changes to 1.769.410.24

(Attach the stickers .24 and hardware -21 to the board)

SERVO BOARD A727 1.769.410.21 → .22/23\* → .24 •

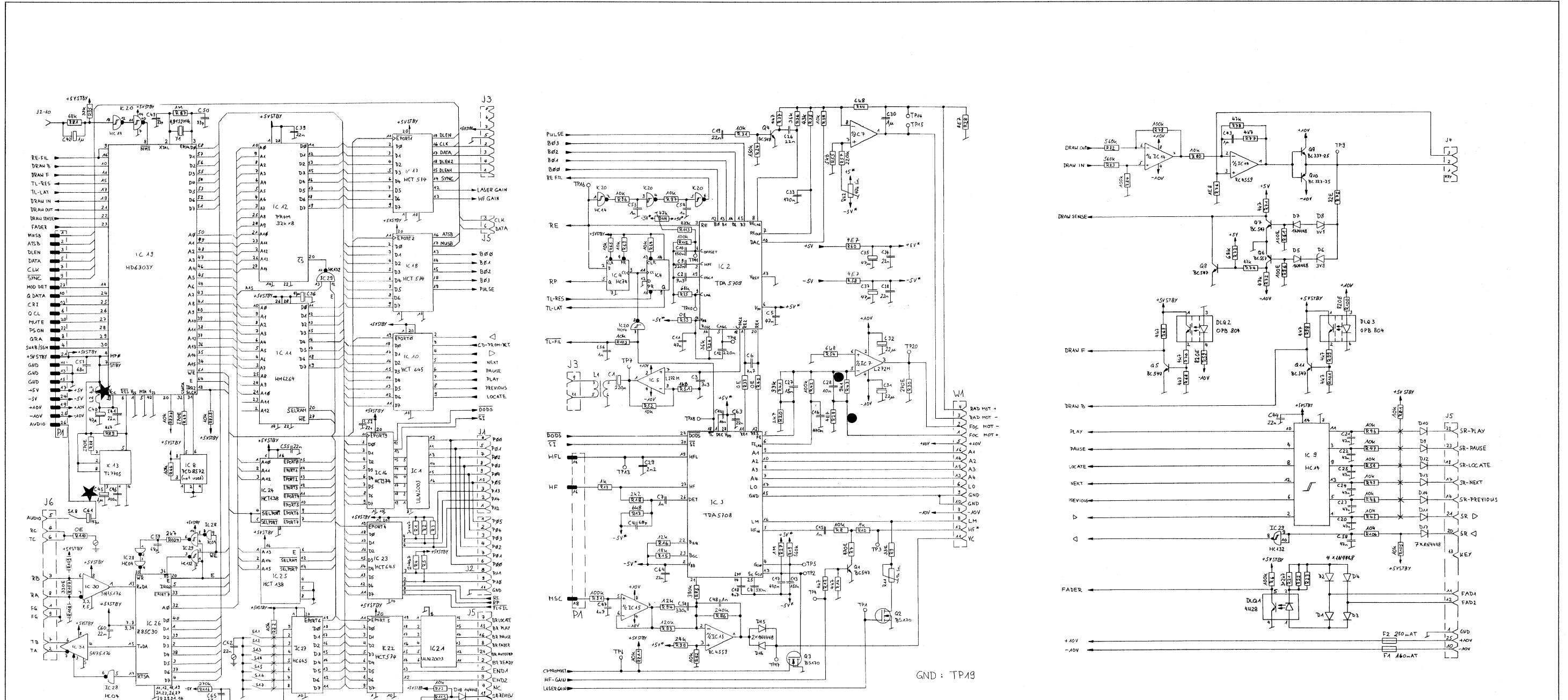

① 302287 Mini	② 10487 Mini	③ 210527 Mini	④ 180827 Mini	⑤ . . .
STUDER A727 CD PLAYER				
PAGE 1 OF 3				
STUDER	SERVO BOARD	SC	1.769.410.21	

① 302287 Mini	② 10487 Mini	③ 210527 Mini	④ 180827 Mini	⑤ . . .
STUDER A727 CD PLAYER				
PAGE 2 OF 3				
STUDER	SERVO BOARD	SC	1.769.410.21	

① 302287 Mini	② 10487 Mini	③ 210527 Mini	④ 180827 Mini	⑤ . . .
STUDER A727 CD PLAYER				
PAGE 3 OF 3				
STUDER	SERVO BOARD	SC	1.769.410.21	

- ★ L2 → replaced by wire
  - ★ C45 → 10µF
  - C28 → 100pF
  - R29 → 2.2Ω
- } .21 → .22/23  
} .22/23 → .24

SERVO BOARD A727 1.769.410.21 →.22/23★→.24●

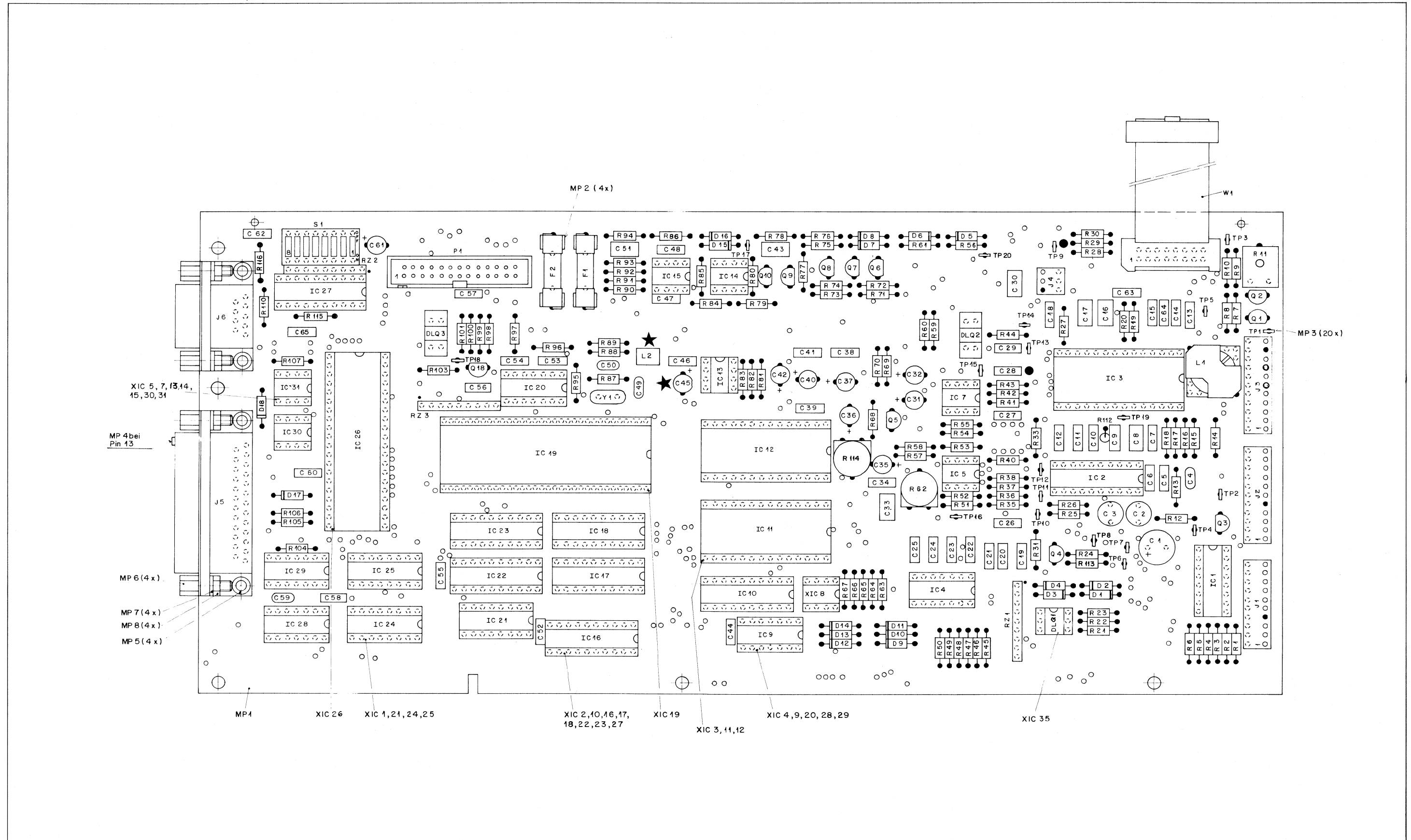



4.2 DECODER BOARD 1.769.430.81

Um die Betriebssicherheit der +12V und -15V Speisespannungen zu erhöhen, werden die Längstransistoren Q3 und Q4 durch einen stärkeren Typ ersetzt. R62 muss individuell für jeden Decoder SAA7210 abgeglichen werden, und zwar wie folgt:

- Anstelle von R62 (1M5) zwei Steckkontakte (53.03.0228) einlöten
- Widerstandsdekade (>100kΩ) an diese Punkte anschliessen
- Oszilloskop an TP2 anschliessen, Signal EFAB (Error Flag A to B-Chip)
- PHILIPS Test CD5, Track 1 abspielen.
- Mit dem höchsten Widerstandswert (∞) gemäss untenstehender Tabelle beginnend, soll das Signal EFAB beobachtet werden. Der Widerstandswert soll in den angegebenen Schritten sukzessiv verkleinert werden (390k, 360k, 330k, 300k ect.), bis EFAB Signale (5V-Pulse) auftauchen. Die Beobachtungsdauer sollte jeweils etwa 10 sec. betragen. Sobald also 5V-Pulse auftreten, soll der vorgängige Wert nochmals eingestellt und dann gemäss Tabelle der Wert R62 ermittelt werden.

Beispiel: / example:

Dekadeneinstellung /  
setting on resistance decade box

∞  
390 k  
360 k  
330 k  
300 k

4.2 DECODER BOARD 1.769.430.81

For increased reliability of the +12V and -15V supply voltages the transistors Q3 and Q4 are replaced by a more powerful type. Each decoder SAA7210 has to be adjusted individually by means of R62 according to the instructions below:

- Solder two contact pins (53.03.0228) in place of R62 (1M5)
- Connect a resistance decade box (>100kΩ) to these points
- Connect a scope to TP2, signal EFAB (error flag A to B-chip)
- Play Test CD5 from PHILIPS, Track 1.
- Watch the signal EFAB beginning with the maximum value (∞) listed in the table below. Decrease the value by means of the resistance decade box in steps which are listed in the table (390k, 360k, 330k, 300k ect.) until you can see pulses of 5V (EFAB) on the scope. Do this procedure for every value for about 10 sec. As soon as you notice such 5V-pulses set resistance to previous value again to verify that these pulses disappear. Now can you find the corresponding value for R62 by means of the table.

Beobachtung /  
picture on scope

kein / no EFAB  
kein / no EFAB  
kein / no EFAB  
kein / no EFAB  
5V - Pulse erscheinen /  
5V - pulses present

Gemäss Tabelle findet man den einzustellenden Wert von 2M2 bei der Dekadeneinstellung von 330k. Es ist also jener Wert entscheidend, bei dem gerade noch keine 5V-Pulse auftreten.

According to the table you find the value 2M2 which has to be chosen at a setting of 330k on the decade box. Always select the last value just before the 5V-pulses begin to appear.

Tabelle / Table:

Einstellung mit  
Widerstandsdekade /  
Setting on resistance  
decade box

—> R62

---

∞  
390k  
360k  
330k  
300k  
270k  
240k  
220k  
200k  
180k  
160k

---

---

∞  
∞  
6M8  
2M2  
1M5  
820k  
620k  
510k  
390k  
330k  
270k

---

- Q3 (BC 327) ändert auf ZTX 751 S (50.03.0352)
- Q4 (BC 337) ändert auf ZTX 651 S (50.03.0523)

- Q3 (BC 327) changes to ZTX 751 S (50.03.0352)
- Q4 (BC 337) changes to ZTX 651 S (50.03.0523)

VORSICHT: Die neuen Transistoren müssen richtig eingelötet werden!  
(Siehe Layout und Gehäuseform)

NOTE: The new transistors have to be soldered correct!  
(See layout and shape of the housing)

- DECODER BOARD 1.769.430.81 ändert auf 1.769.430.82.  
  
(Indexschild .82 anbringen)

- DECODER BOARD 1.769.430.81 changes to 1.769.430.82.  
  
( Attach the sticker .82 to the board)

DECODER BOARD A727 1.769.430.00 →.81★ →.82●

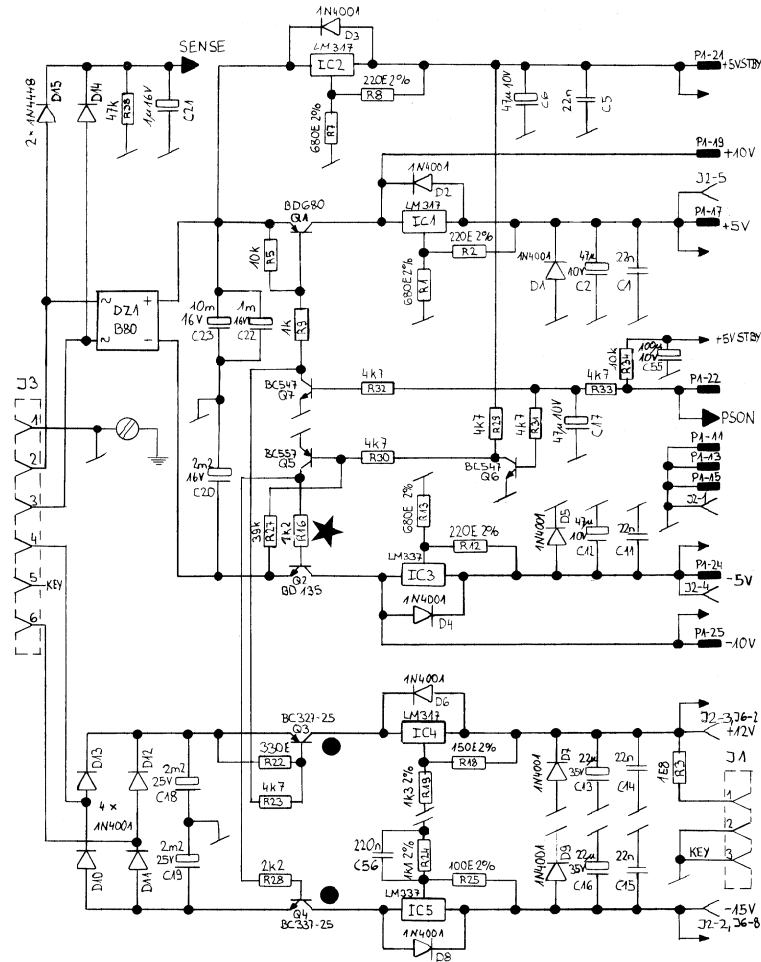

④ 4.1186 S Wicki	① 70027 Miani	② 120527 Miani	③ 51027 Miani	④ . . .
STUDER A727 CD-PLAYER				
PAGE 1 OF 3				
STUDER	DECODER-BOARD	SC	1.769.430.00	

- ★ R60 → 470Ω
  - ★ R61 → 1k2
  - R16 → 1k2
- } .00 → .81

- Q3 → ZTX 751S
  - Q4 → ZTX 651S
  - R62 → indiv.adj.
- } .81 → .82

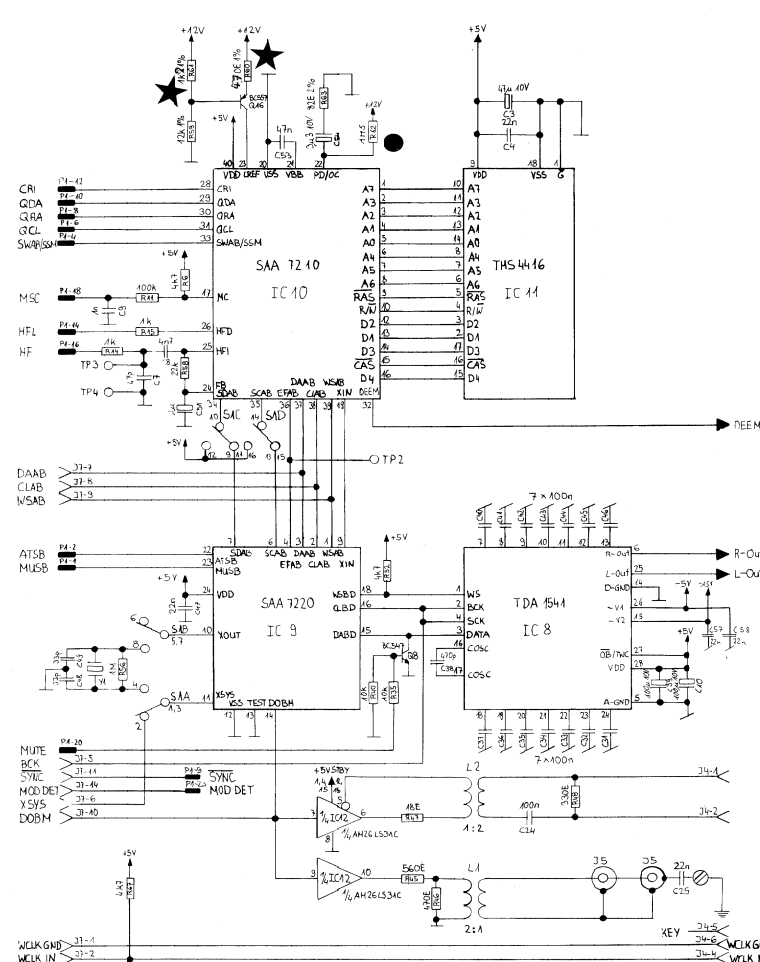

④ 4.1186 S Wicki	① 70027 Miani	② 120527 Miani	③ 51027 Miani	④ . . .
STUDER A727 CD-PLAYER				
PAGE 2 OF 3				
STUDER	DECODER-BOARD	SC	1.769.430.00	

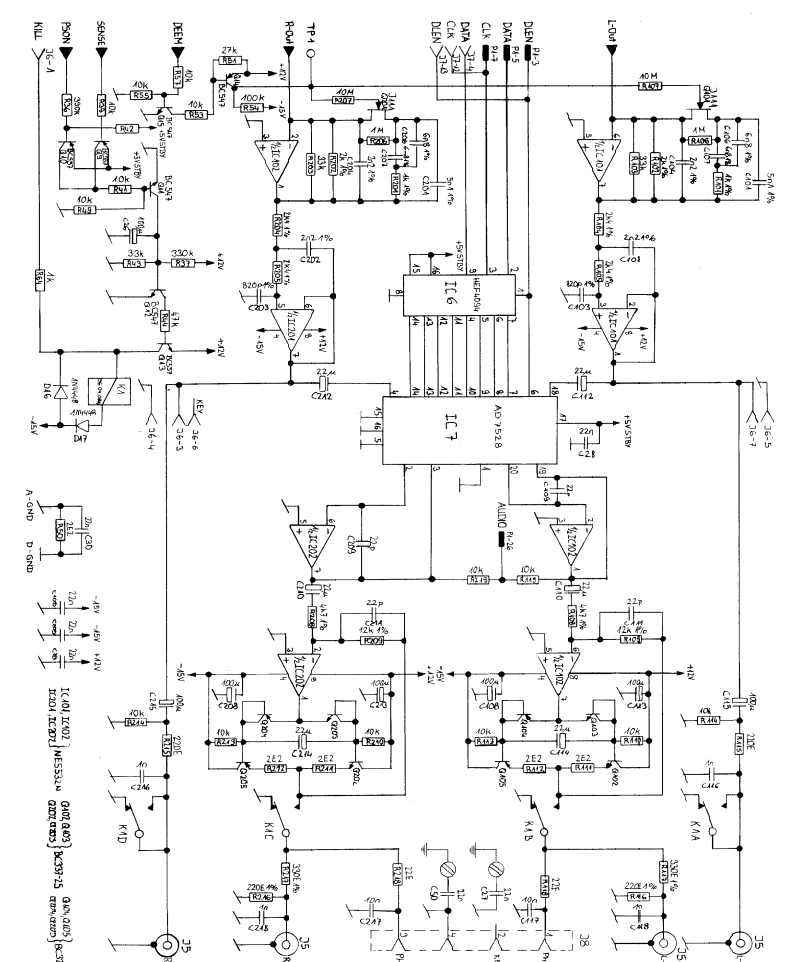

④ 4.1186 S Wicki	① 70027 Miani	② 120527 Miani	③ 51027 Miani	④ . . .
STUDER A727 CD-PLAYER				
PAGE 3 OF 3				
STUDER	DECODER-BOARD	SC	1.769.430.00	

DECODER BOARD A727 1.769.430.00 — .81★ — .82●

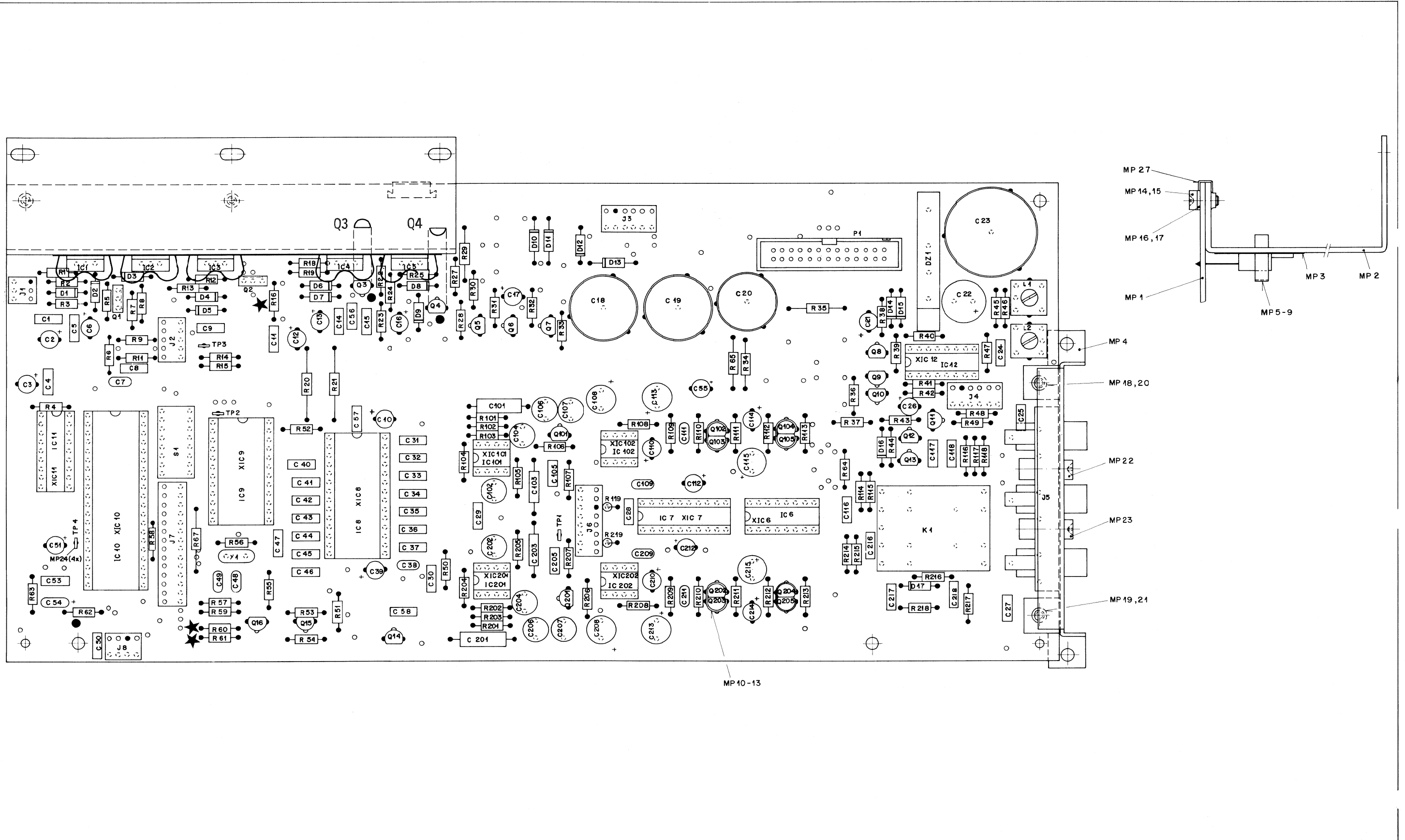

## TECHN. INFORMATION

**TI 77/90**  
**ES-BUS Specification**

10.85.1310

**Studer Philips ES Bus Specification.**

---

---

(Release 8. Date: 29.11.89)

---



---

## Summary

---



---

1 Scope and Introduction.....	1
1.1 Scope .....	1
1.2 Introduction.....	1
2 Glossary.....	2
3 Bus Components.....	3
4 Bus Controller.....	5
4.1 Operation .....	5
4.2 Address Allocation.....	6
5 Command and Message Format.....	8
6 ES Bus Studer Philips Command/Status Transfer Protocol.....	8
7 Reports (information fields).....	9
7.1 Introduction.....	9
7.2 Information Field Data Transfer.....	9
7.3 Transmitting Information Fields.....	10
7.4 Common Tributary Information Field Definition .....	11
7.4.1 Introduction .....	11
7.4.2 Machine type: 21 [hex] .....	11
7.4.3 Equipment Type: 22 [hex] .....	12
7.5 Information field definition .....	13
7.5.1 Introduction .....	13
7.5.2 Status report: 40 [hex] .....	13
7.5.3 Timecode Report: 41 [hex] .....	15
7.5.4 TOC Report: 42 [hex].....	16
7.5.5 Disc Number: 43 [hex].....	19
7.5.6 ISRC Number: 44 [hex].....	19
7.5.7 Disc Identifier: 45 [hex] .....	19
7.5.8 Current Cue: 46 [hex] .....	20
7.5.9 Cue 1, 2, 3: 47 [hex].....	20
7.5.10: 48 [hex] - FF [hex] .....	21
7.6 Information Field Automated Reporting.....	22
8 Errors and Error Reporting.....	23
8.1 Introduction.....	23
8.2 Error Reports.....	23
8.3 ES Specified Error Reporting .....	23
8.3.1 Error: 29 [hex] .....	23
8.3.2 Cannot do: 2A [hex].....	23
8.3.3 Error status: 2B [hex].....	24
8.3.4 Error status response: 2C [hex] .....	24
8.4 Automatic Error Reporting.....	25
9 ES Common Message Subset.....	25
10 Commands .....	25
11 ES Studer Philips Common Message Command Subset.....	26

12 CD Player Tributary Commands .....	26
12.1 CD Player Commands .....	26
12.2 Command Keyword List.....	26
12.2.1 Keyword 40 - Start Disc.....	26
12.2.2 Keyword 41 - Stop Disc.....	27
12.2.3 Keyword 42 - Pause.....	27
12.2.4 Keyword 43 - Play.....	27
12.2.5 Keyword 44 - Access to Start of Track .....	28
12.2.6 Keyword 45 - Access to Start of Track and Index .....	28
12.2.7 Keyword 46 - Access on Absolute Time.....	28
12.2.8 Keyword 47 - Jump Real Tracks .....	29
12.2.9 Keyword 48 - Repeat Play Segment .....	29
12.2.10 Keyword 49 - Set Stop Cue to Absolute Time .....	30
12.2.11 Keyword 4A - Set Stop Cue to End of Track .....	30
12.2.12 Keyword 4B - Set Stop Cue to End of Track and Index.....	31
12.2.13 Keyword 4C - Clear stop cue .....	31
12.2.14 Keyword 4D - Set Start at Beginning of Modulation .....	31
12.2.15 Keyword 4E - Clear Start at Beginning of Modulation .....	32
12.2.16 Keyword 4F - Set Stop at Modulation End .....	32
12.2.17 Keyword 50 - Clear Stop at Modulation End .....	33
12.2.18 Keyword 51 - Reset Cue Points .....	33
12.2.19 Keyword 52 - Set Volume Level .....	33
12.2.20 Keyword 53 - Set Varispeed Value.....	34
12.2.21 Keyword 54 - Return to Start Cue (LOCATE) .....	34
12.2.22 Keyword 55 - Fader Start Enable.....	34
12.2.23 Keyword 56 - Fader Start Disable .....	35
12.2.24 Keyword 57 - Open Drawer on Drawer Loaders .....	35
12.2.25 Keyword 58 - Auto Pause On.....	35
12.2.26 Keyword 59 - Auto Pause Off.....	36
12.2.27 Keyword 5A - Audio Mute On.....	36
12.2.28 Keyword 5B - Audio Mute Off.....	36
12.2.29 Keyword 5C - Remote ON.....	36
12.2.30 Keyword 5D - Remote Off .....	37
12.2.31 Keyword 5E - Lock keyboard.....	37
12.2.32 Keyword 5F - Unlock keyboard .....	37
12.2.33 Keyword 60 - End review.....	37

This specification is the responsibility of the Studer-Philips joint venture group.



## 1 Scope and Introduction

### 1.1 Scope

This report is a specification defining the use of the ES bus within the Studer-Philips joint venture group. All future products will comply to this specification to maintain compatibility.

It is not an intention of this specification to reiterate the structure of a general ES bus system, only the specific portion relating to the Studer Philips bus components will be considered. For more information of the ES bus the reader is referred to the specification Remote-control systems for television production equipment, Technical Document 3245-E issued by the European Broadcasting Union, Brussels.

### 1.2 Introduction

The ES bus hardware and software protocol is a joint recommendation of the EBU (European Broadcasting Union) and the SMPTE (Society of Motion Picture and Television Engineering). Details can be found in the EBU document TEC 3245 with the supplements 1 (Housekeeping protocol), 2 (VTR dialects) and 3 (ATR dialects).

The ES bus is a serial multipoint bus using the RS 422 electrical standard. Communication rate is a standard 38.4 kbit/s using a binary transmission format.

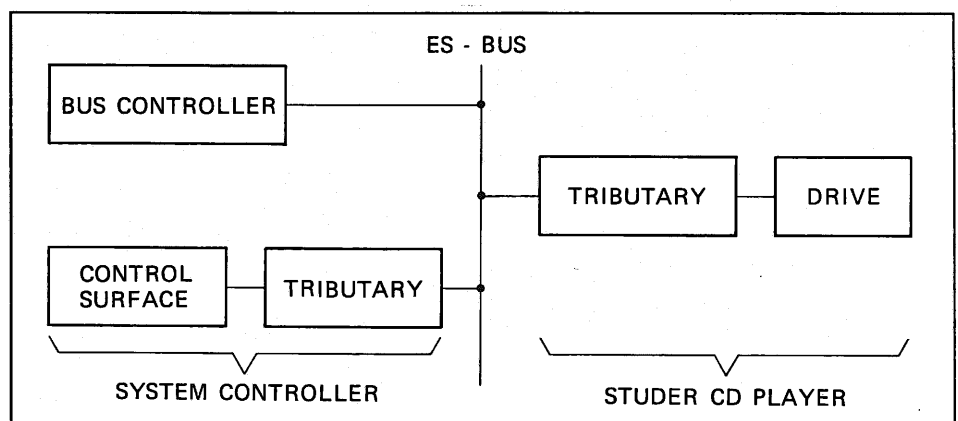

Fig. 1.

The interfaces connected to the ES-bus are called "tributaries". They all look identical to the bus, but different towards the drives connected.

In addition, there is a bus controller (not to be confused with the system controller). The bus controller controls the bus traffic and acts as an arbitrary device. Each device on the bus has a specific address, all devices communicate by using the address to define which message is for which device. The contents of control messages are completely user definable but must be transmitted within the format of message communication defined in the ES bus specification.

## 2 Glossary

---

ES:	EBU/SMPTE bus.
CD:	Compact Disc.
VCT:	Virtual Controlled Tributary. This can normally be interpreted as a controlled device (e.g. CD-Player, CD recorder, etc).
VMa:	Virtual Manager. This can normally be interpreted as a controller associated with a VCT. It will generally be a keypad and display.
VM:	Virtual Machine. ES bus term for a tributary.
TOC:	Table of contents.
ID:	Identification.
VTR:	Video Tape Recorder.
ATR:	Audio Tape Recorder.
RS422:	The electrical definition of possible multipoint bus specifications used for the ES bus.

### 3 Bus Components

---

Within an ES bus system there are two possible components:

#### Bus controller

The bus controller will handle all information transfers on the bus. It is responsible for ensuring that messages originating from one source on the bus will be forwarded to the correct destination. No other device on the bus is allowed to initiate communication. All devices will respond to requests from the bus controller.

#### Tributaries

A tributary is simply a device on the bus which has an associated bus address. The bus controller can poll/send messages to or receive messages from tributaries on the bus by selecting the tributary address.

For the Studer Philips ES specification tributaries are further divided into three categories.

- **Virtual Controlled Tributary (VCT)**  
These are defined to be unintelligent tributaries having no control capabilities on the bus. These tributaries simply take commands/status request from intelligent tributaries and action on them. They do not themselves issue operational commands to another tributary but simply respond to operation and status commands from an intelligent tributary. Examples of VCT's are CD players, CD changers, CD recorders, etc. They can however be instructed by the controlling device to issue requests when a prespecified action has occurred. They are referred to as VIRTUAL controlled tributaries as a real device (e.g. a dual CD recorder) may physically contain more than one device controlled by the same local system (e.g. a microprocessor system). Each of the devices has an individual tributary address which the local system must use to determine for which device a message is intended. Thus one real device of this sort contains two VIRTUAL controlled tributaries. The bus simply considers each of the VCT's to be a totally individual tributary.
- **Virtual Managers (VMa)**  
A virtual manager is the associated controlling device for a VCT. In general terms it will be a keypad and display system. Entering keys will cause a message to be transmitted on the bus to the corresponding VCT. There should always be one VCT associated with one VMa (and vice versa). As with VCT's the word VIRTUAL manager is used so as to allow one real device to contain several managers. The more logical Virtual controller term has been avoided to eliminate confusement with the term bus controller.
- **Gateway**  
A gateway is the means by which the Studer Philips ES system will connect to other ES systems. It is simply a translation system taking tributary addresses from other systems and converting them into the required Studer Philips addressing structure.

The following three diagrams show possible bus configurations.

Virtual Manager controlling 3 CD tributaries (VCT):

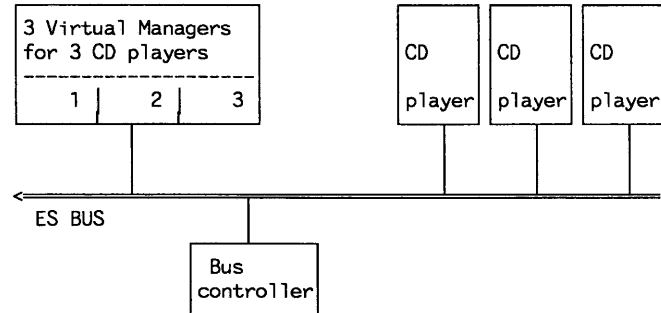

Note: The three VMa's are physically realised by one intelligent unit. Each of the VMa's has an ES tributary address. The players also have one address so total of six ES addresses are in use. The VMa's will never communicate directly to there tributary, only via the bus controller.

Virtual Manager controlling 3 CD tributaries:

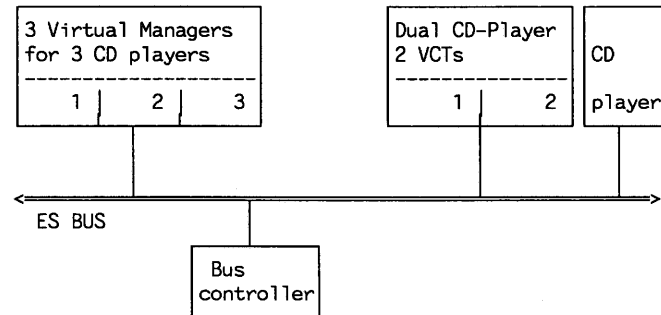

Note : As far as the bus is concerned, this example is exactly the same as the previous one. The Dual CD player will occupy two tributary addresses but each will operate independently. Again six tributary addresses are in use.

Combined Recorder and Player system:

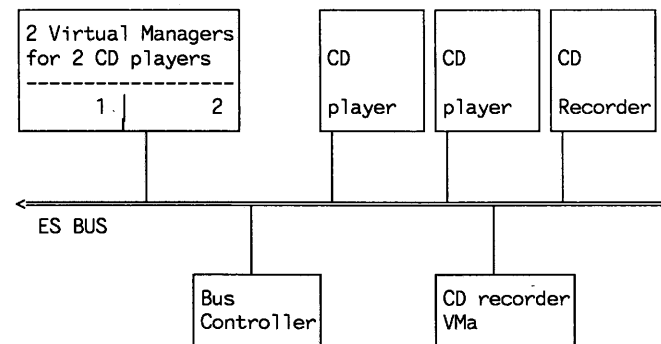

Note : There is one virtual manager connected with each VCT. The variations can be continued. A CD changer could be added provided that a CD changer VMa was available.

## 4 Bus Controller

---

### 4.1 Operation

---

This section provides more details concerning the operation of the bus controller. As stated previously the bus controller is responsible for ensuring that messages originating from a source are transmitted to the correct destination. It achieves this by using the following method.

The bus controller is constantly polling all tributaries on the bus. Polling simply involves requesting the tributary to send a status byte defining its present condition. When a tributary is polled it can respond with one of several specified replies as detailed in the ES specification.

One of these possible replies is known as Service Request.

The service request (SVC) informs the controller that this tributary has a message to send. When the controller has received a service request from a tributary it will send a transmit enable to that tributary. The tributary will then transmit to the controller the message to be transferred. The controller will buffer this message. When the message is complete the controller decides to which tributary the message was intended and will then select that address and retransmit the message.

How does the controller know which tributary is to be connected to which tributary (i.e. which VMa to which VCT and vice versa)?

This information is held in a LINKAGE DIRECTORY. The controller maintains a linkage directory defining source and destination addresses for tributary messages. The controller will poll all source tributaries in the linkage directory looking for the service request message. When it receives a service request the controller will then retransmit the message using the destination address. Thus a LOGICAL link is formed between source and destination tributaries. Consider example 3 of the examples for bus format given previously. If the following tributary (hex) addresses are assigned (note that ES addresses are two bytes, 16 bits long).

8286	VMa for 1 CD player
8288	VCT for 1 CD player
8292	VMa for CD recorder
8294	VCT for CD recorder
82A2	VMa for CD player
82A4	VCT for CD player

Then the linkage directory could be as follows

Source	Destination
8286	8288
8292	8294
82A2	82A4
8288	8286
8294	8292
82A4	82A2

Note that the controller will poll each of the sources in turn so communication is possible in both directions.

## 4.2 Address Allocation

The following section defines address allocation of tributaries on the system.

The ES bus addressing system allows for a maximum of 8064 discrete tributary addresses to be defined, but only sixteen of them are used in the Studer-Philips ES bus organisation. Sixteen devices actually specify two tributary addresses per device as a result of VMA to VCT matching.

The essential problem to overcome is initialising the linkage directory in the controller on power up state. The addressing scheme of the ES bus allows address ranges from 8280[hex] to FFFF[hex], subdivided into groups of 64 tributaries:

8280	82FF [hex]	64 tributaries
8380	83FF [hex]	64 tributaries
...		
FF80	FFFF [hex]	64 tributaries

The bus controller must on power up have the linkage directory to start bus communication. For this reason, all devices within the Studer Philips ES bus will use the most significant digit of the tributary addresses to be F0 [hex]. There will be no option to modify this address. This scheme obviously limits the use of the tributary in a very large ES system but if a conflict of addresses between tributaries is obtained a gateway could be used (or in the extreme different ROM sets in controller and players).

On each of the tributaries the user will have the ability to define 1 of 16 addresses. This will require four bits. The four bits will be mapped into the ES addressing scheme as follows:

BYTE	BINARY CODE	HEX CODE
MS (high)	1111 0000	F0
LS (low)	10XX XX00	??

XXXX these four bits are definable.

Thus the address range of the Studer Philips ES bus will be F080 to F0BC [hex].

The low byte of the tributary address will further be divided as follows:

BYTE	BINARY CODE	HEX CODE
LS (low)	10XX XXYZ	??

where:

- Y is 1 bit defining if the tributary is a VMa or a VCT.
  - "high" is for a VCT
  - "low" is for a VMa

This is not a bit that can be set by switches, it is defined by the ROM set.

- Z is 1 bit defining if the tributary is being selected or polled.
  - "high" is for a POLL address
  - "low" is for a SELECT address

Thus the available VMa addresses are:

F080 (hex) + (n\*4)

(0 ≤ n ≤ 15)

and the available VCT addresses are:

F082 (hex) + (n\*4)

(0 ≤ n ≤ 15)

Each VMa will have a corresponding VCT with the four bits set to the same value to match the device controller and device. For example if the value of XXXX above was 1011 (binary), then the following tributary addresses have been defined for the VMa and the VCT:

F0AC H = Virtual manager select address.  
 F0AD H = Virtual manager poll address.  
 F0AE H = Virtual Controlled Tributary select address.  
 F0AF H = Virtual Controlled Tributary poll address.

This scheme gives a possibility of 16 devices to be controlled on the bus.

The bus controller on power up will poll all 32 default address locations looking for a response. The pairs (VCT and VMa) found to be not present (no answer on poll), will be marked as not present and wont be polled anymore until system reset.

## 5 Command and Message Format

The message format is as defined in the ES specification:

byte 1	= byte count of byte 2 to n
byte 2 to n	= control message
byte n+1	= checksum

Control messages take the following form:

[keyword] [parameter 1..n].
-----------------------------

The keyword defines the actual operation to be completed. Keywords are divided into 3 ranges (all values in hex):

- 00 - 1F:** These are system service messages. They control the higher level functions of the data transfers between bus controller and destination. They will be decoded by the bus controller and may or may not be forwarded onto the destination trib.
- 20 - 3F:** Common Message Subset. The common message subset defines keywords that the ES specification considers will be commonly required among tributaries. Not all of the defined common message subset needs to be implemented, only those required by the device in question.
- 40 - FF:** User defined keywords. These keywords are open for user specification. They will reflect the kind of operation required by the device that they are controlling. Standard dialects (keyword definitions) have already been defined by the ES standard for VTR and ATR type machines. The ES Studer Philips standard will use appropriate keywords from the VTR/ATR standards and define a complete new range of commands. As only 40 to FF keywords can be defined keywords will be duplicated over different types of CD devices (ie the same keyword may be used over CD players and CD recorders but may represent different operations). It is the responsibility of the tributary (device/manager) to determine the operation of the keyword dependent on the type of device.

## 6 ES Bus Studer Philips Command/Status Transfer Protocol

Within the ES bus structure (i.e. ES defined message formats etc) the following section describes how VCT's and VMa's shall communicate. The intention behind this specification is to limit the bus traffic to the very minimum for effective communication. This should therefore speed up bus response to permit priority actions to be transferred promptly.

The transfer protocol has been divided into two sections; those concerned with directing a VCT from a VMa and those concerned with reporting results (information fields) from a VCT to a VMa. The direction of transfer will always be as follows :

VMa >-->-->--> COMMANDS >-->-->--> VCT
VMa <--<--<--< REPORTS(information fields) <--<--<--< VCT



## 7 Reports (information fields)

---

### 7.1 Introduction

---

When a tributary sends data bytes to another tributary the receiving tributary must recognize what type of data packet was being sent. The ES standard introduces the concept of an INFORMATION FIELD. An information field is simply a data structure contained within a tributary which reflects the current status of some condition of the tributary. A tributary can request to read a specific information field from another tributary. This is the mechanism for data transfer between tributaries. As an example an information field for a CD player could be the current laser position. The VMa would issue a read request to the VCT for the laser pen position information field and would receive the laser pen position as a response.

Information fields are numbered like keywords and so a standard for information field numbering between tributaries must be determined.

Information fields have also been divided into various numeric ranges depending on who defined them :

00 - 1F:	Bus controller information fields.
20 - 3F:	Common tributary information fields.
40 - FF:	User defined information fields.

The ES Studer Philips configuration will use information fields taken from all three sources.

### 7.2 Information Field Data Transfer

---

The following descriptions defines the methods by which information fields may be transmitted from tributary to tributary.

There are several mechanisms for a VCT to generate an information field transfer to the VMa.

- by a specific READ request command keyword from a VMa.

The format of this command sequence is:

<READ>	[22 [hex]]
<I/F Name>	[device dependent]

The I/F name is the number assigned to the information field.

- by the UPDATE common message which defines that the information field should be reported whenever its contents change.

The format of the command is:

<UPDATE>	[3F] [07]
<I/F name>	[device dependent]

Note that the command UPDATE is an extension of the common message set. This is the reason why it is a two byte format. The first byte (3F [hex]) defines entry to the extension set and the 07 the UPDATE format.

- by the CYCLE common message which specifies that the information field should be repeatedly reported after a defined elapse of time.

To force time code to be reported after every X frames have elapsed would require the following command.

<CYCLE>	[3F [hex]]
	[08 [hex]]
<I/F Time Interval Value>	[X frames [hex]]
<I/F Time code>	[the number for time code I/F]

- Command Implied. Certain commands will imply that an information field must be passed to the VMa on completion of the command.

For example if the VMa request to a VCT to find the DISC number of a disc then when the VCT has found the disc number it will return the Information Field of the disc number. This is an example of a command implied response. Some commands generated from a VCT will automatically imply a CYCLE or UPDATE sequence (eg when a disc is playing this will imply a cycle command of time code).

### 7.3 Transmitting Information Fields

Information fields are transmitted by a tributary by using the Information Field Response keyword.

The information field response has the following format.

<I/F Response Keyword>	[23 [hex] .... ]
<I/F Name>	[for example Disc Nos .... ]
<I/F value>	[whatever present I/F value is]

The following sequence shows an example of an information field transfer. The VMa requests a time code information field read and the VCT replies with the time code information field.

- VMa sends :

<READ>	[22 [hex] ]
<I/F time code>	[XX ]

- VCT responds :

<I/F Item Response>	[23 [hex] ]
<I/F Time code>	[XX ]
<the actual time code>	[time code]

## 7.4 Common Tributary Information Field Definition

### 7.4.1 Introduction

The following Common Information fields will be supported by all Studer Philips ES equipment.

### 7.4.2 Machine type:21 [hex]

The machine type report can inform the controller what type of equipment is connected. This prevents the controller to send unexecutable commands to the tributaries.

The format for the transmission is defined as follows :

- VMa sends:

<READ>	[22 [hex]]
<I/F MACHINE TYPE>	[21 [hex]]

- VCT responds:

<I/F ITEM RESPONSE>	[23 [hex]]
<I/F MACHINE TYPE>	[21 [hex]]
<machine type>	[.. ]

The byte sent as "machine type" is defined as follows :

01	CD player
02	CD Controller
03	CD Changer
04	CD Recorder
05	Gateway
06	Personal Computer
07-FF	for future definition

7.4.3 Equipment Type:  
22 [hex]

This is a specific product identification included with a software revision number.

The format of the equipment type is as follows:

1. Manufacturer ID.	
2. Product ID.	
3. Revision Level:	- control processor - servo processor - others

All fields will be represented by ISO 646 code characters and each field will be terminated by a 0D (hex).

For example if a VM controller requests for information field 22 from a Studer A730 the following will be transmitted:

[S][T][U][D][E][R]	[0D]
[A][7][3][0]	[0D]
[2][1][.][0][0]	[0D]
[2][0][.][0][0]	[0D]

The [ ] signs show the limits of each byte (they are not transmitted).

All STUDER products will have the following numbering :

- 20.00 is the lowest version number
- 20.01 indicates that this is an update for testing or other purposes but no official release
- 21.00 will be for the first official release of a software update.

The format for the transmission is defined as follows:

- VMA sends:

<READ>	[22 [hex]]
<I/F EQUIPEMENT TYPE>	[21 [hex]]

- VCT responds:

<I/F ITEM RESPONSE>	[23 [hex]]
<I/F EQUIPEMENT TYPE>	[21 [hex]]
<equipment type>	[. ]

7.5 Information field definition

7.5.1 Introduction

The following information fields will be present in all CD related equipment for the Studer Philips ES bus tributaries.

The information fields normally present in a VCT are subdivided into four types.

**Status** This indicates the present status of a subsystem of the VCT.

**Time Code** This information field contains current laser pen position.

**Disc Information** These information fields contain disc specific data. Examples are TOC, ISRC number, DISC number, etc.

**Device Specific** These information fields will cater for specific devices (recorders, changers etc) and are therefore not defined here.

**7.5.2 Status report:40 [hex]** The status information field gives the current VCT status. It is composed of three bytes which are bit significant. The status information field will have the keyword 40 [hex] assigned. It will be passed to the VMa as shown in the following scheme:

[Byte 1]	[Byte 2]	[Byte 3]
----------	----------	----------

Example of a status information field transfer:

- VMa sends:

<READ>	[22 [hex]]
<I/F STATUS>	[40 [hex]]

- VCT responds:

<I/F ITEM RESPONSE>	[23 [hex]]
<I/F STATUS>	[40 [hex]]
<Byte 1>	[.. ]
<Byte 2>	[.. ]
<Byte 3>	[.. ]

The status information field is three bytes in length.

The first byte contains information concerning the mode of the player (AUTO\_CUE, FADER\_PLAY, VARISPEED, AUTO\_PAUSE) and some information about the disc (disc loaded, toc loaded, audio track or data).

The second byte holds information about the laser pen action, about the index and the modulation search.

The third byte will show the player general status.

The status information field will be sent every time there is a status change or in the response to a command which generates an implied status information or in the response to a status request.

#### Byte definition Byte 1 of Status Information Field

D7	D6	D5	D4	D3	D2	D1	D0
NO AUDIO	VARI-SPEED	FADER PLAY	AUTO-CUE ON STOP	AUTO-CUE ON START	AUTO-PAUSE	TOC LOADED	DISC LOADED

D0 - DISC LOADED  
this bit is set when there is a disc in the player and the drawer is closed.

- D1 - TOC LOADED  
this bit is set when the player has read the TOC from the disc after that one was introduced in the player.
- D2 - AUTO PAUSE STATE  
this bit is set when the AUTOPAUSE function is turned ON via player keyboard or by direction of the controlling device.
- D3 - AUTO CUE ON START CUE  
this bit is set when the AUTOCUE function is enabled for the start of the modulation.
- D4 - AUTO CUE ON STOP CUE  
this bit is set when the AUTOCUE function is enabled for the end of modulation.
- D5 - FADER PLAY STATE  
this bit is set when the player is in FADER PLAY state, that means that the player is ready to accept a fader switch command.
- D6 - VARISPEED STATE  
this bit is set when the player's varispeed value is not set to 0 %.
- D7 - NO AUDIO TRACK  
this bit is set when the current track has no audio information (i.e. CD-ROM).

**Byte 2 of Status Information Field**

D7	D6	D5	D4	D3	D2	D1	D0
STOP MOD FOUND	START MOD FOUND	INDEX FOUND	PICKUP IN PAUSE	PICKUP IN SEARCH	PICKUP IN PLAY	PICKUP ON STOP	PICKUP ON START

- D0 - PICK-UP ON START CUE  
this bit is set when the player has found the current start cue and is pausing there.
- D1 - PICK-UP ON STOP CUE  
this bit is set when the player has found the current stop cue and is pausing there.
- D2 - PICK UP IN PLAY  
this bit is set when the player is playing and the audio is unmuted.
- D3 - PICK-UP IN SEARCH  
this bit is set when the player is searching for a cue point or for the modulation.
- D4 - PICK-UP IN PAUSE  
this bit is set when the player is pausing.
- D5 - INDEX FOUND  
this bit is set when the player has found the defined index. It will be reset when the player receives an index access command.
- D6 - START OF MODULATION FOUND  
this bit is set when the player is under AUTOCUE mode and the start of the modulation for the defined track is found.
- D7 - STOP OF MODULATION FOUND  
this bit is set when the player is under AUTOCUE mode and the stop of the modulation was found.

## Byte 3 of Status Information Field

D7	D6	D5	D4	D3	D2	D1	D0
PLAYER IN DIAL	PLAYER IN EDIT	PLAYER POWER OFF	DRAWER OUT/ MOVING	PLAYER START UP	PLAYER STOP	PLAYER IN LOCAL	PLAYER ON AIR

- D0 - PLAYER ON AIR  
this bit is set when the player is playing because the fader switch is gone from closed to opened. The line-out ampl. must be activated.
- D1 - PLAYER IN LOCAL MODE  
this bit is set when the player is switched to the LOCAL mode. The commands sent by the controlling device will be ignored but not the informations from the controlled to the controlling device.
- D2 - PLAYER STOPPED  
this bit is set when the disc in the player is not spinning.
- D3 - PLAYER STARTING UP  
this bit is set when the player is starting to read the inserted disc (focusing, reading lead-in).
- D4 - DRAWER OUT OR MOVING  
this bit is set when the drawer or lid is out or opened and when the drawer is moving (in and out).
- D5 - PLAYER IN POWER OFF  
this bit is set when the player is in power off state.
- D6 - PLAYER IN EDIT  
this bit is set when the player is in edit mode (definition of a cue on the player's keyboard) or when the current cue is changed (i.e. as a result of a cue key operation, toggle operation of AUTOPAUSE, ect.). If the user presses one of the numerical keys, and an A 730 is connected, this device will enter the edit mode and leave it again when the user presses one of the CUE RETURN keys (i.e. CUE\_1 to CUE\_3, LAST\_CUE, PLAY, PAUSE, or FAST\_DIAL)
- D7 - PLAYER IN DIAL  
this bit is set when the player is in dial mode (A730) or when the player is in cueing mode (A727: < and >).

### 7.5.3 Timecode Report: 41 [hex]

Time code Information Fields hold the current laser pen disc position. Time code has been assigned the keyword 41 [hex]. Note that time code information is relevant to CD systems only and does not comply with the ES specification timecode.

The timecode will be passed to the controller as shown below :

[TT]	[II]	[RM]	[RS]	[RF]	[AM]	[AS]	[AF]
------	------	------	------	------	------	------	------

where all items are in BCD and refer to:

TT	track
II	index
RM	relative minutes
RS	relative seconds
RF	relative frames
AM	absolute minutes
AS	absolute seconds
AF	absolute frames.

Relative items define the elapsed time from the beginning of the track to the actual position. Absolute items define the elapsed time from the beginning of the disc to the actual position.

It is the responsibility of the tributary to send the timecode with a constant rate defined by the CYCLE command or by the cycle parameter passed with the command PLAY.

It is equally possible for the controller to ask for the timecode when it needs to know the exact position of the pick-up with the command READ\_I\_F\_ITEM. This is done by the following scheme:

■ VMa transmits

<READ>	[22 [hex]]
<I/F TIMECODE>	[41 [hex]]

■ VCT responds

<I/F ITEM RESPONSE>	[23 [hex]]
<I/F TIMECODE>	[41 [hex]]
<Track>	[02 [hex]]
<Index>	[01 [hex]]
<Rel. mins>	[00 [hex]]
<Rel. secs>	[10 [hex]]
<Rel. frames>	[50 [hex]]
<Abs. mins>	[03 [hex]]
<Abs. secs>	[45 [hex]]
<Abs. frames>	[50 [hex]]

If the timecode is not requested by the VMa, and the tributary sends it because of the cycle, the communication will only consist of the seconds part (VCT responds).

7.5.4 TOC Report:  
42 [hex]

The table of contents report passes to the VMa the table of contents as it is written in the lead-in on the disc.

The format of the TOC is as follows: [control word] [point] [minutes] [seconds] [frames].

The TOC can be transmitted in max three blocks depending on the length of the TOC (number of tracks on the disc). One block can contain max 50 TOC-items. The TOC-items with point numbers A0, A1 and A2 will be treated the same way as the TOC-items with track numbers (5 bytes). They appear at the beginning of the first block transmitted.

The format of the control word is as follows :

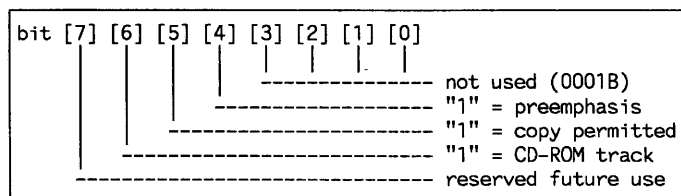

The following example shows a disc with three tracks being transmitted.



- VMa transmits

<READ>	[22 [hex]]
<I/F TOC>	[42 [hex]]

- VCT responds

<I/F Item Response>	[23]
<I/F TOC>	[42]
<control word of A0>	[01]*
<point A0 >	[A0]
<first track number>	[01]
<0 >	[00]*
<0 >	[00]*
<control word of A1>	[01]*
<point A1 >	[A1]
<last track number>	[03]
<0 >	[00]*
<0 >	[00]*
<control word of A2>	[01]*
<point A2 >	[A2]
<start lead-out minutes>	[11]
<start lead-out seconds>	[50]
<start lead-out frames>	[16]
<control word of point 01>	[11]
<point 01 >	[01]
<point 01 start minutes>	[00]
<point 01 start seconds>	[02]
<point 01 start frames>	[32]
<control word of point 02>	[31]
<point 02 >	[02]
<point 02 start minutes>	[03]
<point 02 start seconds>	[12]
<point 02 start frames>	[30]
<control word of point 03>	[31]
<point 03 >	[03]
<point 03 start minutes>	[07]
<point 03 start seconds>	[12]
<point 03 start frames>	[50]

\* : these bytes contain no relevant information for audio discs.

One message on the ES Bus can maximum be 256 bytes long as the byte count for the message is an 8 bit word. For TOC reports containing more than 47 tracks, a second block will be needed and a third one for TOC reports containing more than 97 tracks. After the first block is transmitted, the transmitting tributary will keep its ES-Bus state in SVC (service request) to send the next block after the next poll sequence (see RED BOOK for more information about the TOC structure).

**7.5.5 Disc Number:**  
43 [hex]

This section contains the disc number for the disc in the VCT.

The disc number will be formatted as 13 BCD digits in packed byte form. The last BCD digit (the fourteenth) will always be set to 0000.

In the following example Nx is a four bit BCD digit of a disc number.

■ VMa transmits:

<READ>	[22 [hex]]
<I/F DISC Nos>	[43 [hex]]

■ VCT responds:

<I/F Item Response>	[23 [hex]]
<I/F DISC Nos>	[43 [hex]]
<Disc Nos digits 1,2>	[N1,N2 [hex]]
<Disc Nos digits 3,4>	[N3,N4 [hex]]
<Disc Nos digits 5,6>	[N5,N6 [hex]]
<Disc Nos digits 7,8>	[N7,N8 [hex]]
<Disc Nos digits 9,10>	[N9,N10 [hex]]
<Disc Nos digits 11,12>	[N11,N12 [hex]]
<Disc Nos digits 13>	[N13,0000 [hex]]

**7.5.6 ISRC Number:44 [hex]**

This information field contains the ISRC number of the track specified.

The format of the ISRC number will be passed as 10 bytes. Byte 1 defines the track number to which this ISRC number corresponds (two digits BCD). Bytes 2 to 6 will be in ASCII form, bytes 7 to 10 will be in packed BCD form. The last BCD digit (which follows ISCR field 12) will always be set to 0000.

In the following example Ax is an ASCII value and Nx is a four bit BCD digit value. The x indicates the field of the ISRC number.

■ VMa transmits:

<READ>	[22 [hex]]
<I/F ISRC Nos>	[44 [hex]]

- VCT responds:

<I/F Item Response>	[23 [hex]]
<I/F ISRC Nos>	[44 [hex]]
<ISRC Track Number>	[?? [hex]]
<ISRC fields 1>	[A1 ASCII]
<ISRC fields 2>	[A2 ASCII]
<ISRC fields 3>	[A3 ASCII]
<ISRC fields 4>	[A4 ASCII]
<ISRC fields 5>	[A5 ASCII]
<ISRC fields 6,7>	[N6,N7 [hex]]
<ISRC fields 8,9>	[N8,N9 [hex]]
<ISRC fields 10,11>	[N10,N11 [hex]]
<ISRC fields 12>	[N12,0000 [hex]]

### 7.5.7 Disc Identifier: 45 [hex]

This information field passes to the VMA the disc ID of the disc in the VCT. The disc ID will be constructed as follows (all items are in BCD).

Byte 0	- first track frames value.
1	- second track seconds value.
2	- second track frames value.
3	- lower nibble of maximum track (in BCD) with lower nibble of minutes of leadout time.
4	- seconds value of leadout
5	- frames value of leadout

Note : If there is only one track on the disc then the fields which use second track values will be set to FF [hex].

The following shows a transfer of an ID number:

- VMA transmits:

<READ>	[22 [hex]]
<I/F DISC ID>	[45 [hex]]

- VCT responds:

<I/F Item Response>	[23 [hex]]
<I/F DISC ID>	[45 [hex]]
<DISC ID field 0>	[N0 [hex]]
<DISC ID field 1>	[N1 [hex]]
<DISC ID field 2>	[N2 [hex]]
<DISC ID field 3>	[N3 [hex]]
<DISC ID field 4>	[N4 [hex]]
<DISC ID field 5>	[N5 [hex]]

**7.5.8 Current Cue:**  
46 [hex]

This information field passes the current start and stop cues to the VMa.

The format of the information field for the cue points shall be :

Byte 0 - start cue TT
1 - start cue II
2 - start cue absolute MM
3 - start cue absolute SS
4 - start cue absolute FF
Byte 5 - stop cue TT
6 - stop cue II
7 - stop cue absolute MM
8 - stop cue absolute SS
9 - stop cue absolute FF

If any of the cue positions has not been explicitly defined then the information field will replace that value with an FF [hex] value. The following shows a transfer of a Cue value number.

■ VMa transmits:

<READ>	[22 [hex]]
<I/F Cues>	[46 [hex]]

■ VCT responds:

<I/F Item Response>	[23 [hex]]
<I/F Cues>	[46 [hex]]
<start cue TT>	
<start cue II>	
<start cue absolute MM>	
<start cue absolute SS>	
<start cue absolute FF>	
<stop cue TT>	
<stop cue II>	
<stop cue absolute MM>	
<stop cue absolute SS>	
<stop cue absolute FF>	

**7.5.9 Cue 1,2,3:**  
47 [hex]

This information field passes the cue points defined in CUE1, CUE2 and CUE3. The format of the information field for these cues shall be:

Byte 0 - cue1 TT
1 - cue1 II
2 - cue1 absolute MM
3 - cue1 absolute SS
4 - cue1 absolute FF
5 - status cue1

Byte 6 - cue2 TT
7 - cue2 II
8 - cue2 absolute MM
9 - cue2 absolute SS
10 - cue2 absolute FF
11 - status cue2

Byte 12 - cue3 TT
13 - cue3 II
14 - cue3 absolute MM
15 - cue3 absolute SS
16 - cue3 absolute FF
17 - status cue3

One status byte shall be transmitted for each cue block defining the different function the cues can take. These bytes will be bit significant. Bytes 5, 11 and 17 are to be defined.

If any of the cue positions has not been explicitly defined then the information field will replace that value with an FF [hex] value. The following shows a transfer of a Cue 123 values number.

■ VMA transmits:

<READ>	[22 [hex]]
<I/F Cues 1,2,3>	[47 [hex]]

■ VCT responds:

<I/F Item Response>	[23 [hex]]
<I/F Cues>	[47 [hex]]
<cue1 TT>	
<cue1 II>	
<cue1 absolute MM>	
<cue1 absolute SS>	
<cue1 absolute FF>	
<status cue1>	
<cue2 TT>	
<cue2 II>	
<cue2 absolute MM>	
<cue2 absolute SS>	
<cue2 absolute FF>	
<status cue2>	
<cue3 TT>	
<cue3 II>	
<cue3 absolute MM>	
<cue3 absolute SS>	
<cue3 absolute FF>	
<status cue3>	

7.5.10 48 [hex] - FF [hex]

reserved for future definition.

## 7.6 Information Field Automated Reporting

---

The following part describes the conditions for generating automatic information field transfers from a tributary.

### Status Information Fields

This Information Field will normally have the UPDATE flag attached to it thus causing a Status Information Field to be sent whenever a status change occurs (e.g. when a disc is placed in a player tributary, the player must inform its VMA of the present status of the disc).

### Time Code Information Fields

These information fields will be transmitted to the VMA when the VMA instructs the VCT to report timecode periodically via the CYCLE command. This will normally only happen when the timecode in a VCT is expected to change periodically ie for example when a disc is playing in a player tributary.

In this example the player VMA will instruct the VCT to transmit timecode after every XX frames for example.

### Disc Information Fields

These Information fields are normally generated only as a request from a VMA, unless the information field is generated as a result of an implied command.

## 8 Errors and Error Reporting

---

### 8.1 Introduction

---

Errors are special cases of information fields and have been designated specific ES keywords.

### 8.2 Error Reports

---

The ES specification has reserved specific common messages for the reporting of errors. The error reports of this bus will comply with the ES standard. However due to the limited error reporting capabilities the error mechanism will be extended.

### 8.3 ES Specified Error Reporting

---

#### 8.3.1 Error: 29 [hex]

Informes the VMa that the previews command he sent was not understood by the tributary.

The format for the transmission is :

ERROR>	[29 [hex]]
Byte count>	[ ]
OFFENDING COMMAND>	[ ]

#### 7.3.2 Cannot do: 2A [hex]

Informes the VMa that the previous command was understood but could not be processed by the VCT due to the reason specified in the EXEC Code.

The format for the transmission is :

<CANNOT DO>	[ 2A [hex] ]
<EXEC CODE>	[ ]

The following Exec Codes are defined.

F0	- Cannot do by design (ie if a VMa directs a CD player to record).
F1	- Insufficiently equipped.
F2	- Buffer Overflow.
F3	- reason given in error status.
F4 - FF	- for future definition

**8.3.3 Error status:  
2B [hex]**

Directs the VCT to transmit the error status.

The format for the transmission will be :

- VMA transmits:

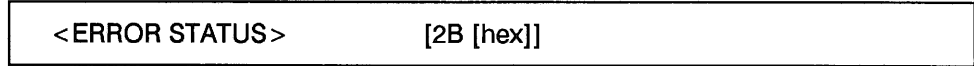

- VCT responds:

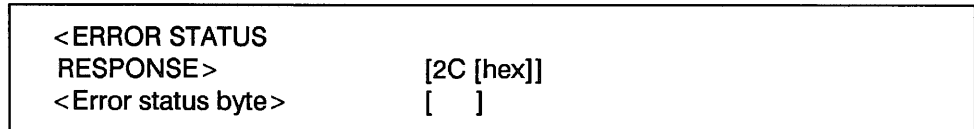

The error status byte is bit significant and will have the following definition.

**Error Status Byte.**

D7	D6	D5	D4	D3	D2	D1	D0
		NO TIME	NO TRACK	LOCAL MODE	NO INDEX	NO DISC	FATAL

- D0 / FATAL - Severe Fatal Error. This error is generated if the error in the CD player is so serious that it can no longer function on the ES bus.  
Causes of fatal errors are:
  - servo tracking failure such as the disc cannot be read.
- D1 / NO DISC - No disc present. This error is generated whenever the VMA issues a command which requires a disc operation. When the disc is removed, this command will also be sent.
- D2 / NO INDEX - Index not found. This error report is sent only after an index request has been initiated.
- D3 / LOCAL MODE - Player in local mode. This is the response to a VMA command if the player trib is in local mode.
- D4 / NO TRACK - Track not found. This error report is sent when the player was directed to access a track which is not on disc.
- D5 / NO TIME - Time not found. This error report is sent whenever the player was told to access an absolute time which is not on disc or if the pick-up would come into lead-out after a "jump real tracks" command.

**8.3.4 Error status response: see ERROR STATUS  
2C [hex]**



## 8.4 Automatic Error Reporting

---

Reports will be generated whenever there is a failure in a subsystem of the VCT or a failure in a command execution. For example if the VMa directed the CD player to find the disc number and the CD player could not find the disc number then an error report for CD number not found would be transmitted.

The process of events is as follows for a command which could not be executed or failed execution:

- VMa sends command to VCT.
- VCT attempts to execute command, fails and transmits a CANNOT DO message with the reason in the EXEC CODE. If the EXEC CODE specifies that the reason is contained within the error status then the VMa will issue an ERROR STATUS READ to which the VCT will then pass the error status.

## 9 ES Common Message Subset

---

The ES specification defines a common message subset that can be used by all tributaries (as it does a common information field set). The common message subset is detailed in other ES specifications. If the command keyword to be used is from the common message subset then it will be in the range 20 to 3F [hex].

## 10 Commands

---

Commands are simply transmitted as keywords (possibly with parameters) and will be received from the VMa by the VCT via the bus controller. It is not necessary for the VCT to acknowledge command accomplished, however, most commands will have an implied command response in the form of a status/disc information field. If a command fails then it will generate an ERROR common message.

The VCT/VMa interface designer may use keywords 40[hex] to FF[hex] for VCT specific commands. The following common commands are defined for all Studer Pilips applications. Note that these are taken from the VTR/ATR dialects and the common message subset.

## 11 ES Studer Philips Common Message Command Subset

---

The following list contains the common messages that the Studer Philips tributaries will respond to.

20 [hex]	CNOP	No Operation, does nothing.
21 [hex]	CRESET	Directs the tributary to the power up reset case.
22 [hex]	READ	See 7.2
23 [hex]	I/F ITEM RESPONSE	See 7.3
29 [hex]	ERROR	See 8.3
2A [hex]	CANNOT DO	See 8.3
2B [hex]	ERROR STATUS	See 8.3
2C [hex]	ERROR STATUS RESPONSE	See 8.3
3F07 [hex]	UPDATE	See 7.2
3F08 [hex]	CYCLE	See 7.2

## 12 CD Player Tributary Commands

---

### 12.1 CD Player Commands

---

These commands are issued from the CD Player virtual manager to a CD player tributary (or virtual tributary). The CD player tributary will report information fields if the command implies a response.

Note that this list is not complete and will be appended to as and when needed.

All parameters are in BCD, if not stated otherwise.

### 12.2 Command Keyword List

---

#### 12.2.1 Keyword 40: Start Disc

**Parameters:** None.

**Action:** The motor starts and tracking servos are switched on.

The player will load the TOC and on completion will pause on the first track, index 1, still spinning.

**Notes:** It should not be necessary for the manager to request the player to start the disc when under remote control. This is an automatic operation performed after the lid of the player is closed. The only situation when the manager will instruct the player to start the disc is if the manager also issued a stop command to the player.

**Implied Information Fields Reported:** Status: Disc Inserted, TOC loaded.

- Errors Generated:**
- No disc present.
  - Servos tracking failed.

**12.2.2 Keyword 41:  
Stop Disc**

**Parameters :** None.

**Action :** The motor stops and laser is switched off.

**Notes:** All internal variables of the CD player will be cleared (i.e. TOC, cue points, etc.). A CD Manager normally does not instruct the CD player to stop the disc.

**Implied Information  
Fields Reported:** None.

**Errors Generated:** None.

**12.2.3 Keyword 42:  
Pause**

**Parameters:** None.

**Action:** The player will pause at the current laser pen position. Audio will be muted.

**Notes:** None.

**Implied Information  
Fields Generated:** None.

**Errors Generated:** None.

**12.2.4 Keyword 43:  
Play**

**Parameters:** 1 byte defining the time code CYCLE rate.

This command specifies an implied cycle value for the time code information field. The value given will be the update rate in frames. This means that, if for example the CYCLE is specified as 40 frames, the CD-player will set its state on SVC after all 40 frames to send a timecode I/F after having been selected by the bus controller. A cycle value of 0 will define that NO timecode update is required.

**Action :** The player will play from the current laser position.

**Notes:** The lid will not be automatically locked on play. The lid will be locked automatically when the fader line becomes active (and fader start being enabled).

**Implied Information  
Fields Reported:**

- Status: Player on stop cue when the laser pen reaches the default or defined stop cue.
- Time Code: Dependent on the CYCLE rate.

**Errors Reported:** No disc in player.

## 12.2.5 Keyword 44: Access to Start of Track

**Parameters:** 1 byte defining the track number to access to.

**Action:** The player will access to the start of the track number and pause at this position.

**Notes:** If start on modulation has been selected then it is the responsibility of the player tributary to search for the start of modulation. The tributary will only report on start cue status when it has found the start of modulation.

**Implied Information Fields Generated:** ■ Status: Laser pen on start cue.

**Errors Reported:** None.

## 12.2.6 Keyword 45: Access to Start of Track and Index

**Parameters:** 2 byte defining the track number and index to search for. The parameter order will be track followed by index.

**Action:** The player will search for the track and index specified in the parameters and pause at this position.

**Notes:** If after the index search the index is found not to be in this track then the laser pen will pause on the start of track, index 1. If the index is found then the start on modulation flag will be ignored.

**Implied Information Fields Generated:** Status: Index found, on start cue.

**Errors Reported:** ■ Access failed, index not on disc. This error also implies that the laser is now pausing at the beginning of the track.  
■ Access failed, track not on disc.

## 12.2.7 Keyword 46: Access on Absolute Time

**Parameters:** 3 bytes defining the absolute position to access to. Parameter order will be minutes, seconds, frames.

**Action:** The player will attempt to access to the specified position.

**Notes:** This command sets a new start cue. Start on modulation flag will be ignored.

**Implied Information Fields Generated:** Status: Start cue present.

**Errors Reported:** Time not on disc.

### 12.2.8 Keyword 47: Jump Real Tracks

**Parameters:** 2 bytes. One defines the direction, the second byte defines the number of real tracks to jump. The direction byte is either 00 or FF(hex), 00 is jump forwards (ie towards the leadout). FF(hex) is jump backwards (i.e. towards the leadin).

**Action:** The player will jump the number of real tracks defined in the direction specified by the second byte.

**Notes:** The player state after the jump will be the same as the player state before the jump. If the player was playing then the player will continue to play. If the player was pausing then the player will pause at the new position.

If the jump caused the laser pen to go into the leadout or into the leadin then the laser pen will pause on the leadout or track 1, index 1 positions respectively. No other track jumping commands will be accepted unless in the opposite direction from that which caused the error.

The jumping does not effect the start cue/stop cue positioning.

If the jumping causes the laser position to go outside of the start cue/stop cue boundary, an error report outside start/stop cue will be generated. The laser will pause on the respective start cue/stop cue.

**Implied Information  
Fields Generated:** None.

**Errors Reported** In leadin, leadout, outside cue range.

### 12.2.9 Keyword 48: Repeat Play Segment

**Parameters:** 3 parameters defining the absolute time on the disc at which to start the repeat play. The parameters will be in the order minutes, seconds and frames.

**Action:** The player will access to the position specified in the parameters and will repeatedly play a segment of the disc starting from this position.

**Notes:** The repeat play segment will be terminated by any command which requires a laser action (pause, play, etc).

This command sets a new start cue.

**Implied Information  
Fields Generated:** None.

**Errors Reported :** Access failed, access over leadout, will cause segment into leadout/leadin.

## 12.2.10 Keyword 49: Set Stop Cue to Absolute Time

**Parameters:** 3 bytes defining the absolute stop cue time in minutes, seconds, and frames.

**Action:** The player will set the stop cue to this position.

**Notes:** When the laser pen reaches the stop cue the player will generate a status report defining laser pen on stop cue.

If the player was playing the player will continue playing. There will be no interruption in the play when a set stop cue time is received. It is not expected that the stop cue will be set after the start cue.

If the stop cue has been set before the present start cue then the stop cue will be ignored and an Error generated, attempted stop cue before start cue generated.

If the AUTOPAUSE function was enabled it will be reset by this command if the defined stop cue is not into or at the end of the track defined in the start cue.

**Implied Information  
Fields Generated:** Status: Laser pen on stop cue.

**Errors Reported:** Position not on disc, stop cue before start cue.

## 12.2.11 Keyword 4A: Set Stop Cue to End of Track

**Parameters:** 1 byte defining the track at which to set the stop cue to the end of.

**Action:** The stop cue will be set to the end of the track specified. This will take account of the stop on modulation flag searching for the end point if necessary.

**Notes:** When the player reaches the stop cue the player will generate a status report defining laser pen on stop cue.

If the stop cue has been set before the present start cue then the stop cue will be ignored and an Error report, attempted stop cue before start cue generated.

If stop on modulation is selected then the player will search for the required stop position before assigning the stop cue. If stop on modulation is not selected then the player sets the stop cue to the beginning of the next track.

**Implied Information  
Fields Generated:** Status: Laser pen on stop cue.

**Errors Reported:** Position not on disc, stop cue before start cue.

**12.2.12 Keyword 4B:  
Set Stop Cue to End of  
Track and Index**

**Parameters:** Two bytes in the order track/index defining the track, index of the stop cue.

**Action:** Causes a search for the specified track and index+1 and the stop cue to be set at that position. The laser pen will then be positioned on start cue.

**Notes:** When the player reaches the stop cue the player will generate a status report defining laser pen on stop cue.

If the stop cue has been set before the present start cue then the stop cue will be ignored and an Error report, attempted stop cue before start cue generated.

If the player cannot find the track/index then the stop cue will be set to the end of the track specified.

**Implied Information  
Fields Generated:** Status: Laser pen on stop cue.

**Errors Reported:** Position not on disc, stop cue before start cue.

**12.2.13 Keyword 4C:  
Clear stop cue**

**Parameters:** None.

**Action:** The stop cue is set to the leadout time.

**Notes:** None.

**Implied Information  
Fields Generated:** None.

**Errors Reported:** None.

**12.2.14 Keyword 4D:  
Set Start at Beginning of  
Modulation**

**Parameters:** None.

**Action:** This keyword causes the player tributary to go into "start at beginning of modulation" mode. The tributary will not do anything until it receives an access command.

**Notes:** It will be the responsibility of the servo system to find the modulation start point. This will then set the new cue position.

The modulation start will always cause a search for modulation when the player tributary has been directed to access to a track only. Accesses to track and index absolute times will cause no modulation search.

The modulation search will be performed from the defined start of track to 5 secs after the track. If, however, at the start of the track the modulation threshold is exceeded then a repetitive backwards search in jumps of 3 frames will be performed to ensure that the real start at the beginning of the modulation is found but it will never be set in the previous track (this is the responsibility of the CD-player).

**Implied Information Fields Generated:** Status: Modulation start found, laser pen on start cue.

**Errors Reported:** None.

#### 12.2.15 Keyword 4E: Clear Start at Beginning of Modulation

**Parameters:** None.

**Action:** This command will clear the "start at beginning of modulation" mode.

**Notes:** None.

**Implied Information Fields Generated:** None.

**Errors Reported:** None.

#### 12.2.16 Keyword 4F: Set Stop at Modulation End

**Parameters:** None.

**Action:** This keyword causes the player tributary to go into "stop at modulation end" mode.

**Notes:** It will be the responsibility of the servo system to find the modulation end point. This will then set the new stop cue position.

The modulation threshold defines the level at which audio is considered to be present.

Modulation stop is only important when a specific track has been defined as the stop cue point. It will not be used for accesses to absolute time, track, or index.

**Implied Information Fields Generated:** None.

**Errors Reported:** None.



**12.2.17 Keyword 50:  
Clear Stop at Modulation  
End****Parameters:** None.**Action:** This command will clear the "stop at modulation end" mode.**Notes:** None.**Implied Information  
Fields Generated:** None.**Errors Reported:** None.**12.2.18 Keyword 51:  
Reset Cue Points****Parameters:** None.**Action:** This keyword will cause the start and stop cue to be assigned to track 1 index 1 and leadout position respectively. The laser pen will pause at the start of track 1 index 1.**Notes:** None.**Implied Information  
Fields Generated:** None.**Errors Reported:** None.**12.2.19 Keyword 52:  
Set Volume Level****Parameters:** 1 byte defining the volume.**Action:** This keyword command will set the level of the monitor function of the player tributary.**Notes:** None.**Implied Information  
Fields Generated:** None..**Errors Reported:** None.

## 12.2.20 Keyword 53: Set Varispeed Value

**Parameters:** 2 bytes defining the varispeed level in terms of signed percentage.

byte 1	= most significant digit and polarity.
byte 2	= lower digit percentage value. This will only have the range 0 to 9 and represents a tenth of the percentage change.

e.g.:	[01],[3]	= 1.3 % change.
	[F0],[3]	= -0.3 % change.
	[0B],[8]	= 11.8 % change.
	[FA],[5]	= -10.5 % change.

**Action:** This keyword command will cause the varispeed to become functional.

**Notes:** The allowed maximal values must not be exceeded (A 730:  $\pm 10\%$ ).

**Implied Information  
Fields Generated:** None.

**Errors Reported:** None.

## 12.2.21 Keyword 54: Return to Start Cue (LOCATE)

**Parameters:** None.

**Action:** The laser pen of the CD trib will return to the presently defined start cue. The laser pen will then pause at this point.

**Notes:** None.

**Implied Information  
Fields Generated:** Status: Laser pen on start cue.

## 12.2.22 Keyword 55: Fader Start Enable

**Parameters:** None.

**Action:** The player will now take account of the fader state and will report changes in fader state information field.

**Notes:** None.

**Implied Information**      Status: Fader Open.  
**Fields Generated:**

**12.2.23 Keyword 56:  
Fader Start Disable**

**Parameters:**      None.

**Action:**      The player will now ignore the fader state and will not report changes in fader value.

**Notes:**      None.

**Implied Information**      None.  
**Fields Generated:**

**12.2.24 Keyword 57:  
Open Drawer on Drawer  
Loaders**

**Parameters:**      None.

**Action:**      This command will cause the drawer of any drawer loader to open. The internal variables of the CD player will be reset (i.e. disc unloaded).

**Notes:**      None.

**Implied Information**      None, implied by a load.  
**Fields Generated:**

**12.2.25 Keyword 58:  
Auto Pause On**

**Parameters:**      None.

**Action:**      This command will cause auto pause to be selected on the player. Auto pause is the state where the player will stop playing after playing the currently selected track. Note that there should never be any reason to set this mode but is provided in the ES specification for players that already support auto pause (or it's equivalent).

**Notes.**      None.

**Implied Information**      None.  
**Fields Generated:**

**12.2.26 Keyword 59:  
Auto Pause Off**

**Parameters:** None.

**Action:** This command will cause auto pause to be reset on the player.

**Notes:** None.

**Implied Information  
Fields Generated:** None.

**12.2.27 Keyword 5A:  
Audio Mute On**

**Parameters:** None.

**Action:** This command will cause the output of the CD player to be muted. The muting is effected by causing the digital output from the decoding of the CD signal to be zero (i.e. passes a value of zero to the D/A converter). This provides a soft mute.

**Notes:** The mute is in effect until the player is told to play or an Audio Mute Off command is sent.

**Implied Information  
Fields Generated:** None.

**12.2.28 Keyword 5B:  
Audio Mute Off**

**Parameters:** None.

**Action:** This command is the opposite of the Audio Mute On. It simply does not force a digital zero value on the signal to the D/A output.

**Notes:** None.

**Implied Information  
Fields Generated:** None.

**12.2.29 Keyword 5C:  
Remote ON**

**Parameters:** None.

**Action:** Switches the tributary into "remote on" mode.

**Notes:** None.

**Implied Information  
Fields Generated:**

None.

**12.2.30 Keyword 5D:  
Remote Off****Parameters:** None.**Action:** Switches the tributary into "remote off" mode.**Notes:** None.**Implied Information  
Fields Generated:** None.**12.2.31 Keyword 5E:  
Lock keyboard****Parameters:** None.**Action:** Locks the keyboard of the tributary.**Notes:** None.**Implied Information  
Fields Generated:** None.**12.2.32 Keyword 5F:  
Unlock keyboard****Parameters:** None.**Action:** Unlocks the keyboard of the tributary.**Notes:** None.**Implied Information  
Fields Generated:** None.**12.2.33 Keyword 60:  
End review****Parameters:** None.**Action:** Gets the player to play 8 seconds before stop cue.**Notes:** If the stop cue is less than 8 seconds after the start cue, then the player plays from start to stop cue.

**Implied Information  
Fields Generated:**

None.