

Service Manual

REVOX A77



1. CONTENTS

	Page
2. GENERAL	4
2.1. Front Panel Rear Panel	5
3. DISMANTLING	6
3.1. Removal of Housing	6
3.2. Removal of Cover Panel	6
3.3. Removal of Front Panel	6
3.4. Removal of Power Switch	6
3.5. Removal of Brake Unit	7
3.6. Removal of Reel Motors	7
3.7. Removal of Capstan Motor	8
3.8. Removal of Control Board	8
3.9. Removal of Power Transformer	9
3.10. Removal of Amplifier Cards	9
3.11. Removal of Potentiometer	10
3.12. Removal of Switch Board	10
3.13. Removal of Frame (Removal of Rotary Switches)	11
4. MECHANICS	12
4.1. Headblock	12
4.1.1. Tape Guides	12
4.1.2. Head Mounting	12
4.2. Tape Tension	13
4.3. Brakes (Stop)	13
4.3.1. Brake Torque Measurement	13
4.3.2. Brake Adjustment	13
4.4. Pressure Roller	14
4.4.1. Pressure Measurement	14
4.4.2. Pressure Solenoid Readjustment	14
4.4.3. Exchange of Pressure Roller	14
4.4.4. Pressure Lever Readjustment	14
4.5. Capstan Motor	15
4.5.1. Removal of Capstan Axis, Ball Bearings	15
4.6. Exchange of Reel Motor Bearings	16
4.7. Lubrication	16
4.8. End-of-Tape Switch	16
5. ELECTRONICS	18
5.1. Switch Board and VU-Meter Board	18
5.2. Input Amplifier	19
5.3. Record Amplifier	19
5.4. Oscillator	20
5.5. Record Relay	20
5.6. Playback Amplifier	20
5.7. Power Amplifier (Loudspeaker Amplifier)	21
5.8. Power Supply	21
5.9. Drive Control	22
5.9.1. Photoelectric End-of-Tape Switch	23
5.10. Speed Regulation, Capstan Motor	23
6. ELECTRICAL ADJUSTMENTS AND MEASUREMENTS	26
6.1. Demagnetizing	26
6.2. Tape Speed	26
6.2.1. Pick-up Head - Adjustment	26
6.2.2. Tacho Adjustment	26
6.2.3. Tacho Adjustment with Cathode-Ray Oscilloscope	26

6.3.	Playback Adjustment		26
6.3.1.	Azimuth Adjustment, Playback Head, Coarse (Max Level)		27
6.3.2.	Azimuth Adjustment, Playback Head, Fine (Phase Method)		27
6.3.3.	Playback Level from Test Tape		27
6.3.4.	Frequency Characteristic, Playback (from Test Tape)		27
6.4.	Oscillator and RF-Adjustment		28
6.4.1.	RF-Voltages and Frequency Checking		28
6.4.2.	Dummy Load		28
6.4.3.	RF-Traps, Record		28
6.4.4.	RF-Traps, Playback		29
6.5.	Record - Adjustments		29
6.5.1.	Azimuth Adjustment, Record Head, Coarse		29
6.5.2.	RF-Bias		29
6.5.3.	Azimuth Adjustment, Record Head, Fine		30
6.5.4.	Record Level		30
6.5.5.	Record Equalization		30
6.5.6.	Frequency Characteristic via Tape		30
6.6.	Distortion Factor Measurement		30
6.6.1.	Distortion Factor (via Tape), VU-Meter Calibration		30
6.6.2.	Noise Voltage (and External Voltage) via Tape		31
6.6.3.	Noise Voltage, External Voltage " Before Tape " (Check)		31
6.6.4.	Erase Attenuation		32
6.6.5.	Crosstalk, Mono		32
6.6.6.	Crosstalk, Stereo		32
6.7.	Output Voltage Check		33
6.8.	Wow and Flutter		33
7.	ACCESSORIES		34
7.1.	Remote Control		34
7.2.	Timing Switch Operation		34
8.	MODIFICATIONS		35
8.1.	Rewind		35
8.2.	Switch Noise		35
8.3.	RFI		35
8.4.	Transfer Play Sensitivity		35
8.5.	Replacement of Capstan Motor		35
8.6.	Capstan Motor with Sleeve Bearings		35
8.6.1.	Removal of Capstan Shaft and low-friction Thrust Washer		35
9.	TROUBLE SHOOTING		36
9.1.	Faults in the Drive		36
9.2.	Faults in the Circuitry		39
10.	DIAGRAMS		Diag. 1
	Tape Drive	1.077.100	Diag. 2
	VU-Meter Board	1.077.480	Diag. 3
	Switch Board	1.077.435	Diag. 3
	Input Amplifier	1.077.700	Diag. 4
	Record Amplifier	1.077.705	Diag. 5
	Oscillator	1.077.712	Diag. 6a
	Record Relay	1.077.715	Diag. 7
	Playback Amplifier	1.077.720	Diag. 8
	Loudspeaker Amplifier	1.077.850	Diag. 9
	Speed Control	1.077.725	Diag. 10
11.	REPLACEMENT PARTS LIST		
12.	SPECIAL VERSION		
12.1.	Revox A77 – DOLBY		

2. GENERAL

The Stereo-Recorder can be obtained as CHASSIS, WALNUT CABINET, and CARRYING CASE models. Here are the applicable codes (order numbers)

	With 2 Output Ampl.	With 2x2 Loudspeakers	Codes	
			2-Track	4-Track
Wood Cabinet			1102	1104
Wood Cabinet	X		1122	1124
Carrying Case	X	X	1222	1224
Chassis			1302	1304
Chassis	X		1322	1324

Outline and Installation Dimensions, see : S 1

Following codes apply to accessories only :

Output Amplifier (per Channel)	1900
Walnut Cabinet	1950
Carrying case, incl. Cover and 2x2 Loudspeakers	1960

The basic configuration is identical for all models. A pressure cast aluminum alloy chassis supports the 3-motor drive, one is the electronically regulated capstan motor. All amplifiers are plug-in modules.

An exchange service is organized for the circuit cards. Faulty cards will be exchanged at minimum charge by factory representatives in the respective country. The same applies to etched circuit boards with connectors (control board, regulator, motor control, switch board).

This permits a very efficient service, limiting, in most cases, repair work to finding the faulty module.

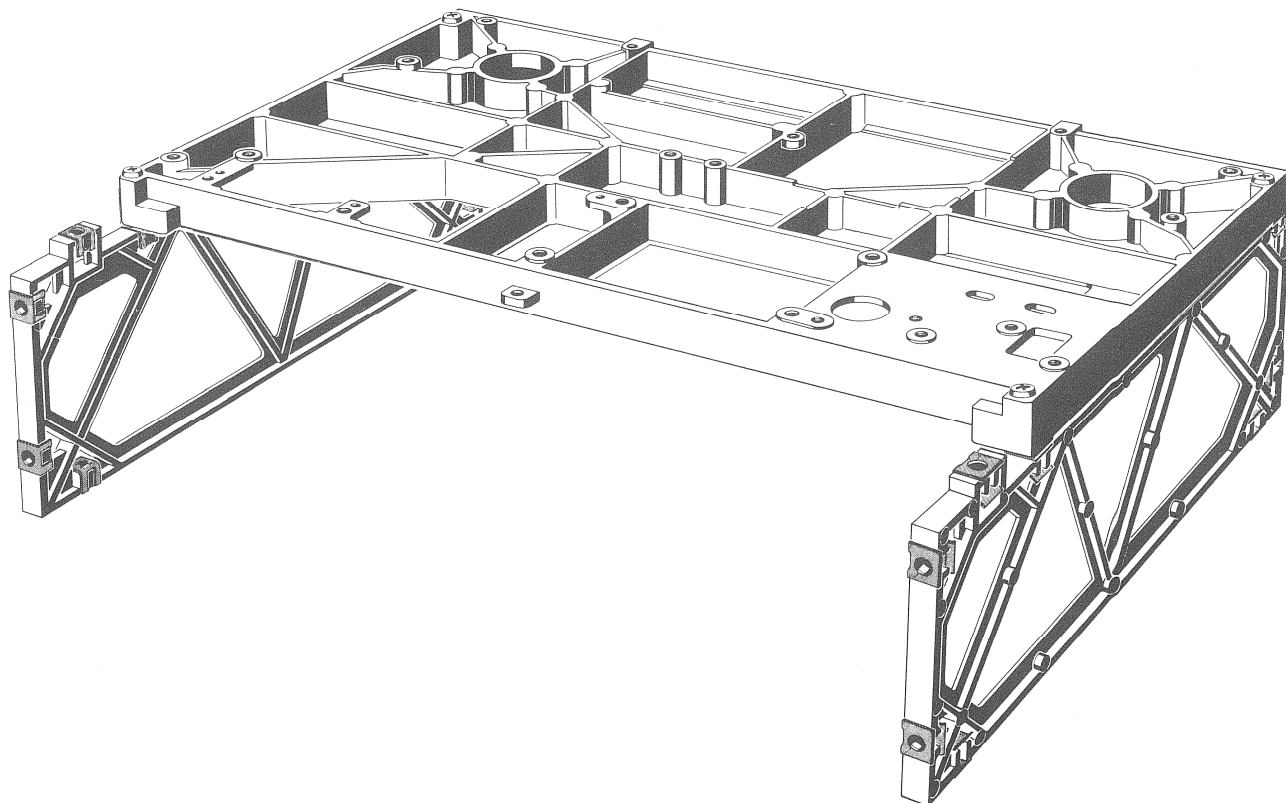

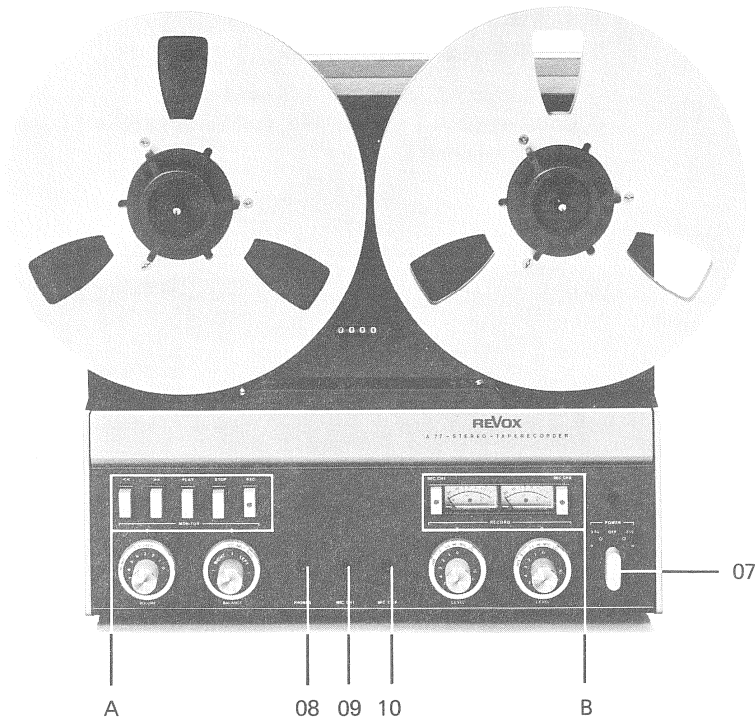

Fig. 2.1-1

2.1. Front Panel, Rear Panel
 (Numbering corresponds to REVOX manual)

A Push buttons

- << Fast rewind
- >> Fast forward
- PLAY Playback
- STOP Stops all operating functions
- REC Record (depress simultaneously PLAY)

B VU-Meters, record pre-selector buttons

- Record CH 1 (upper track) :
Depress left record pre-selector button
- Record CH 2 (lower track) :
Depress right record pre-selector button
- Record Stereo (both tracks) :
Depress both record pre-selector buttons

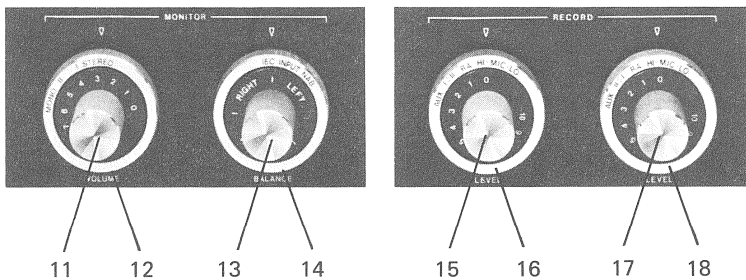

Fig. 2.1-2

- 07 Power switch, tape speed, tape tension
- 08 Headphone socket (200 - 600 Ohm)
- 09 Microphone socket, CH 1
- 10 Microphone socket, CH 2
- 11 Playback volume control
- 12 Playback mode switch
- 13 Balance control
- 14 Before-and-after tape switch
- 15 Record volume control, CH 1
- 16 Input selector, CH 1
- 17 Record volume control, CH 2
- 18 Input selector, CH 2

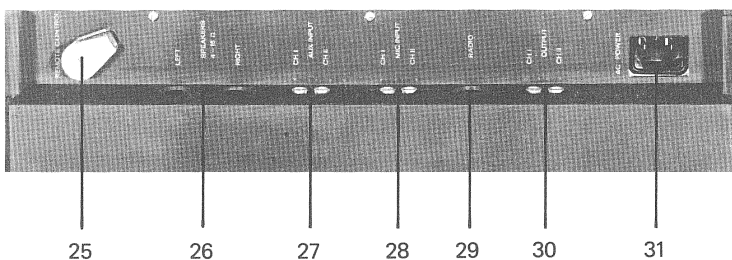
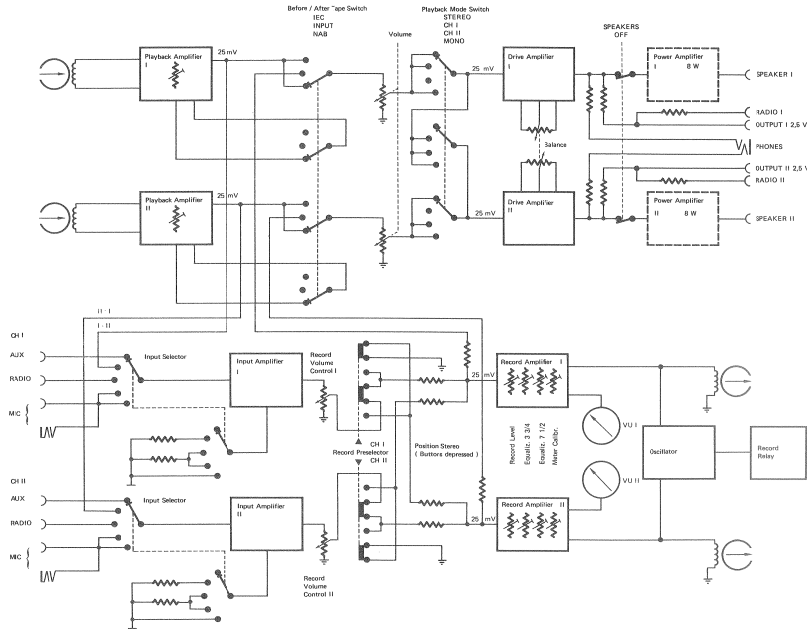

Fig. 2.1-3

- 25 Remote control plug
- 26 Loudspeaker socket (DIN, 4 - 16 Ohm)
- 27 AUXILIARY - Input (35 mV)
- 28 Microphone - Input (.15/2,5 mV)
- 29 RADIO, DIN connection: Input 2,5 mV
Output 1,2 V
- 30 OUTPUT (2.5 V / 600 Ohm)
- 31 Socket for power cable

REVOX A77



General Measurement Conditions : (for voltages in rectangular frames)

D.C. Voltages : vertical letters - e.g. $\boxed{12V}$ Meter internal resistance 20 kOhm / V min.

A.F. Voltages : slant letters - e.g. $\boxed{25mV}$ Meter: Vac, tube or transistor voltmeter 1 MOhm min.

Markings on Tantalum Electrolytic Capacitors

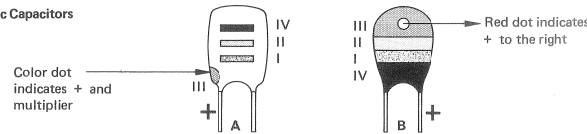

Color (pink**)	Capacitance in μF			Working voltage IV
	1st digit I	2nd digit * II	multiplier III	
black	—	0	x 1	10 V
brown	1	1	x 10	—
red	2	2	—	—
orange	3	3	—	35 V**
yellow	4	4	—	6 V
green	5	5	—	15 V
blue	6	6	—	20 V
violet	7	7	—	—
gray	8	8	x 0,01	25 V
white	9	9	x 0,1	3 V

* possibly missing on model B

** 35 V on model A: pink

TECHNICAL DETAILS

- Tape transport :** 3 — motor deck. Electronically governed capstan-motor. Electronic speed change.
- Tape speeds :** 3 3/4 and 7 1/2 ips. $\pm .2\%$
- Wow and flutter :** max. $\pm .08\%$ at 7 1/2 ips.
(weighted) max. $\pm .1\%$ at 3 3/4 ips.
- Tape slip :** less than .2%
- Tape spool diameter :** max. 10.5"
- Operating position :** Horizontal or vertical
- Amplifiers :** Equipped with silicon transistors throughout. Plug-in printed circuit cards
- Frequency response via tape :** 30 Hz — 20 kHz $+2 / -3$ dB } at 7 1/2 ips.
50 Hz — 15 kHz ± 1.5 dB }
30 Hz — 16 kHz $+2 / -3$ dB } at 3 3/4 ips.
50 Hz — 10 kHz ± 1.5 dB }
- Distortion via tape, at 1 kHz peak level and at 0 VU respectively**
7 1/2 ips: max. 2% or 0.6% resp.
3 3/4 ips: max. 3% or 1.0% resp.
- Equalization :** Record : NAB
Playback: NAB and IEC (switchable)
- Signal to noise ratio, via tape, weighted as per ASA A**
7 1/2 ips: min. 66 dB (4 track min. 62 dB)
3 3/4 ips: min. 63 dB (4 track min. 59 dB)
- Cross talk at 1 kHz :** Mono better than 60 dB, stereo better than 45 dB
- Oscillator frequency :** 120 kHz, push - pull oscillator
- Inputs per channel :** Cinch / Jack
5 - pole DIN
Cinch
Microphone, switchable LO/HI
LOW: 50 - 600 Ω .15 mV
HIGH: up to 100 k Ω 2.5 mV
RADIO: 33 k Ω 2.5 mV
AUX: 1 M Ω 35 mV
- Outputs per channel :** Cinch
5 - pole DIN
Jack
OUTPUT max. 2.5 V / Rs 600 Ω
RADIO max. 1.2 V / Rs 2.5 k Ω
PHONES 200 - 600 Ω
- Remote control :** Fully electric for all operating functions
- Output amplifiers :** Plug - in optional
- Output power :** Music power 20 W (10 W per channel) Continuous power 16 W (8 W per channel) Distortion better than 1%
- Output impedance :** 4 — 16 Ω
- Built - in loudspeakers :** Two loudspeakers per channel (automatically disconnected when a plug is inserted into the DIN loudspeaker sockets)
- Transistors, etc.** 54 transistors, 32 diodes, 4 silicon rectifiers, 1 photo resistor, 4 relays
- Power supply :** Electronically stabilized
- Mains voltages :** 110, 130, 150, 220, 240, 250 V~/ 50 - 60 Hz
- Power consumption :** Without output amplifiers 70 W
With output amplifiers approx. 70 - 100 W
- Mains fuses :** 220 — 250 V~/ .5 A
110 — 150 V~/ 1 A
- Weight :** Approx. 34 lbs.

We reserve the right to make technical alterations in the interests of technical improvements.

Dimensions Walnut Cabinet

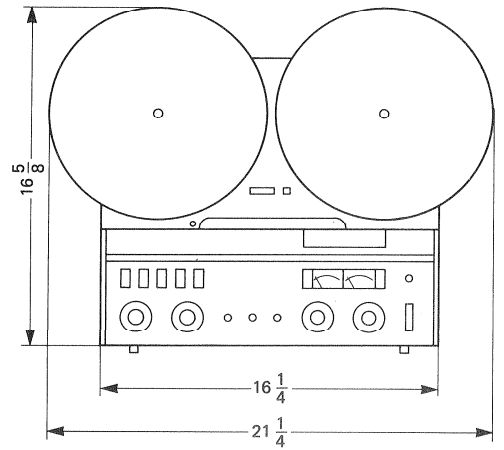
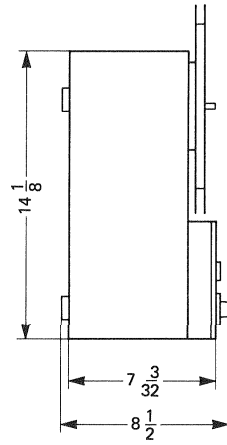

Dimensions Carrying Case

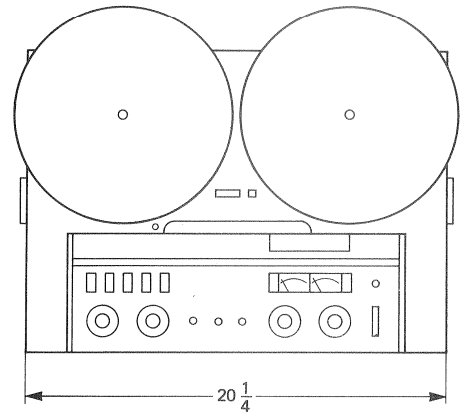
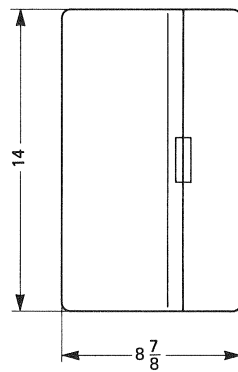

Dimensions Chassis

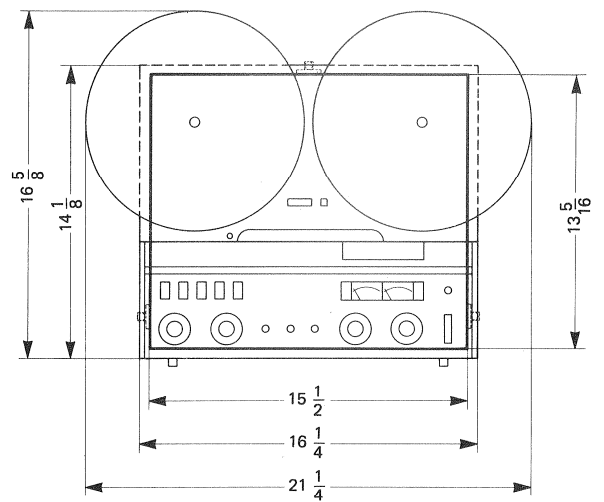
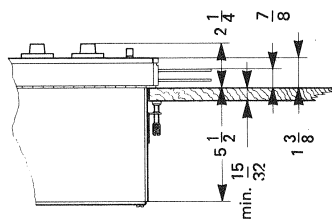

Color Code :

red = red — rouge
 org = orange — orange
 yel = yellow — jaune
 grn = green — vert
 blu = blue — bleu

vio = violet — violet
 brn = brown — brun
 gry = gray — gris
 blk = black — noir
 wht = white — blanc

3. DISMANTLING

Table of Wire Colors

red	=	red	—	rouge	—	Rot
org	=	orange	—	orange	—	Orange
yel	=	yellow	—	jaune	—	Gelb
grn	=	green	—	vert	—	Grün
blu	=	blue	—	bleu	—	Blau
vio	=	violet	—	violet	—	Violett
brn	=	brown	—	brun	—	Braun
gry	=	gray	—	gris	—	Grau
blk	=	black	—	noir	—	Schwarz
wht	=	white	—	blanc	—	Weiss

3.1. Removal of Housing

- Set instrument face down on soft basis. Remove remote control dummy plug.
- Remove housing fasteners. Pull housing carefully upward. Disconnect loudspeaker connectors on regulator card (fig. 3.9–13) in the carrying case.
- Reinsert remote control plug.
- Bridge power disconnect jack (2-pole protective disconnecter) with two insulated banana plugs.

3.2. Removal of Cover Panel

- Tilt access lid down. Pull off head cover.
- Undo screw A (fig. 3.2–4). Pull cover panel off (Upper rim, 3 retainers).

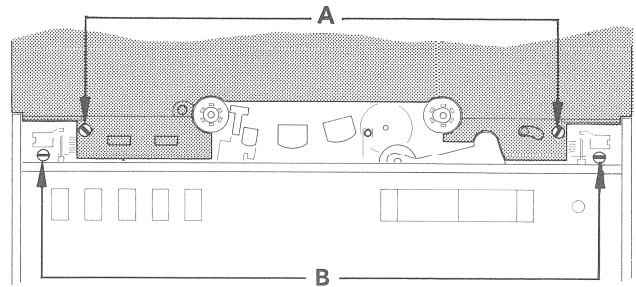

Fig. 3.2–4

3.3. Removal of Front Panel

- Undo screws B (fig. 3.2–4). Pull out power switch knob as well as all rotary knobs and discs. Save retaining ring of power switch.
- Pull up monitor panel (4 retainers).

3.4. Removal of Power Switch

- Disassemble retaining ring of slide switch (equalization switch)
- Unfasten 3 screws. Remove power switch carefully.
- Take off plug connectors.

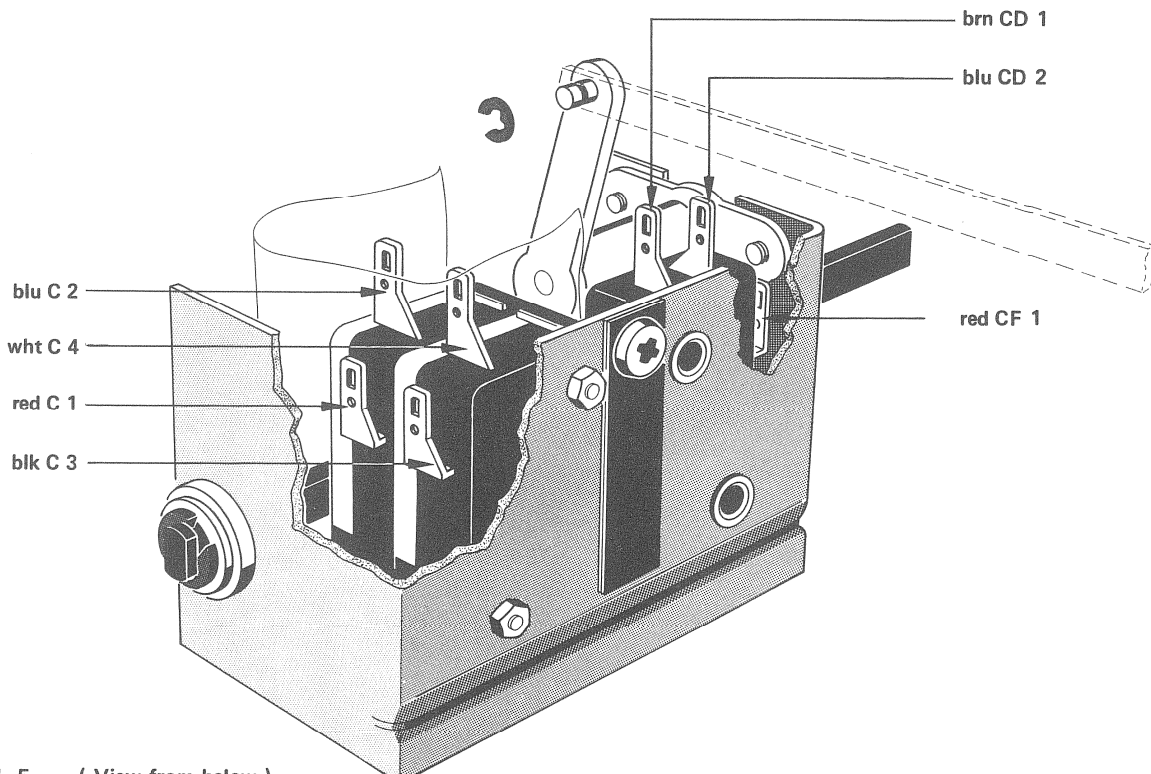

Fig. 3.4–5 (View from below)

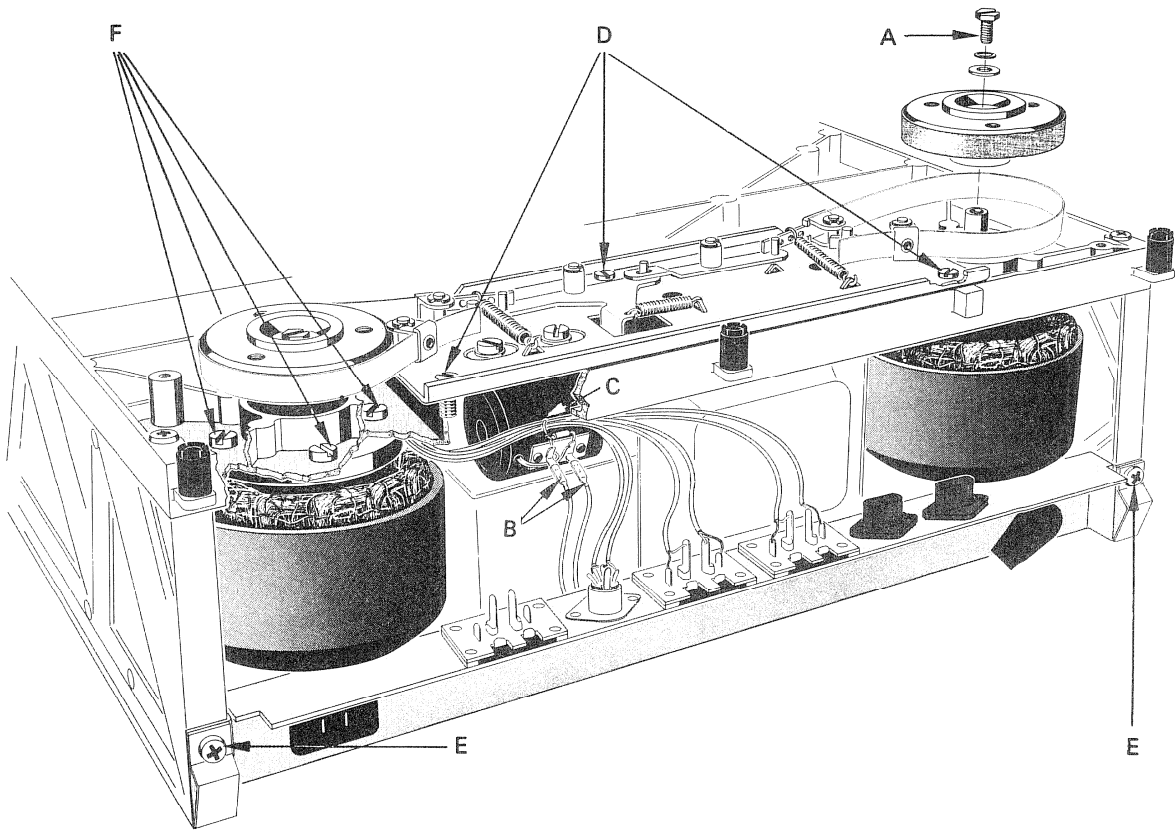

Fig. 3.5-6

3.5. Removal of Brake Unit

- Remove cover panel per 3.2.
- Remove reel plates (3 screws each).
- Brake drums: Undo center screws A (fig. 3.5 -6), loosen brakes and lift drums carefully upward. Be careful not to kink brake bands. Don't touch brake linings. Grease traces reduce braking effect.
- Remove connections B (fig. 3.5 -6).
- Separate cable bundle (shielded wires) at C (fig. 3.5 -6)
- Remove 3 chassis screws D (fig 3.5 -6) and lift chassis carefully out.

3.6. Removal of Reel Motors

- Remove brake drums per 3.5.
- Remove frame screws E (fig. 3.5-6).
- Unplug output amplifiers (if present).
- Unplug motor cable connectors; right reel motor, regulator card (fig. 3.6-7); left reel motor, control card (fig. 3.6-8).

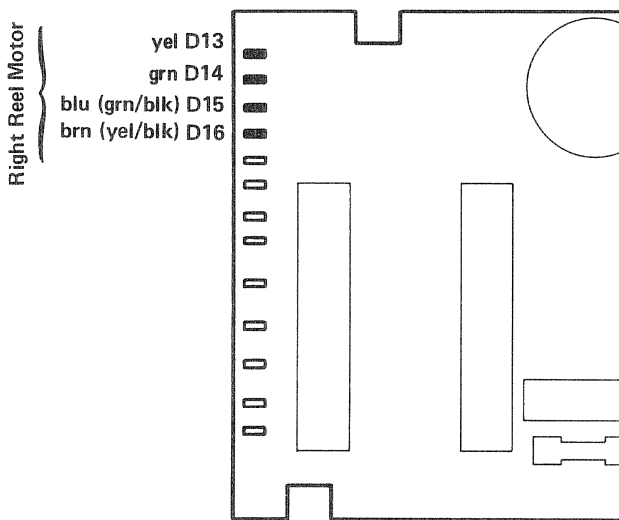

Fig. 3.6-7

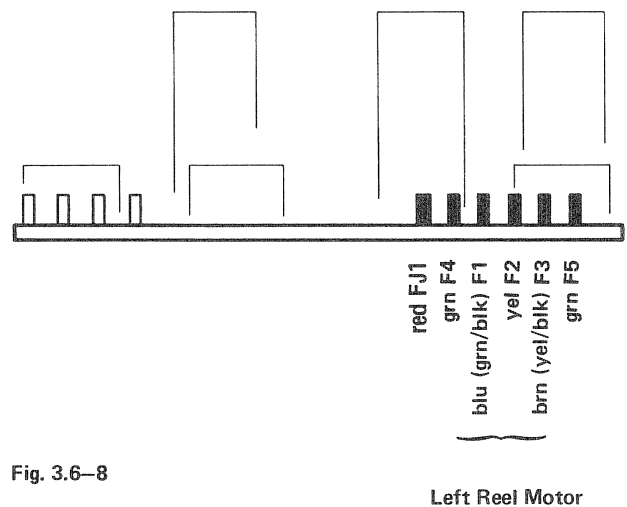

Fig. 3.6-8

- Remove 4 reel motor screws F each (fig. 3.5 -6) and lower motors carefully.

3.7. Removal of Capstan Motor

- Remove output amplifiers (if present).
- Disconnect capstan-motor and pick-up cables; connections are on control card (fig. 3.7 - 9).

Note:

For improved signal to noise performance, the capstan motor connections may be reversed on some recorders in the following manner: E3 = gry, E4 = yel, E5 = grn. Carefully note wire colors before disassembling.

- Undo cable clamps A (fig. 3.7 - 9).
- Remove cover and monitor panels per 3.2. and 3.3.
- Unscrew motor fasteners B (fig. 3.7 - 10) on headblock. The other screws on headblock shall not be touched as they retain the headblock itself.
- Remove capstan motor carefully downward. Guard absolutely against bumping (axis run-out is better than .001 mm = 40 micro - inch !)

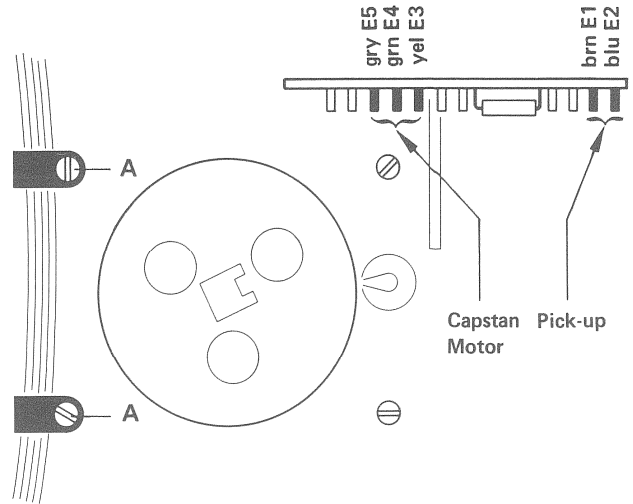

Fig. 3.7-9

3.8. Removal of Control Board

- Remove cover and front panels per 3.2. and 3.3.
- Undo screws A (fig. 3.8-11). Pull control board downward.
- Remove connectors as needed.

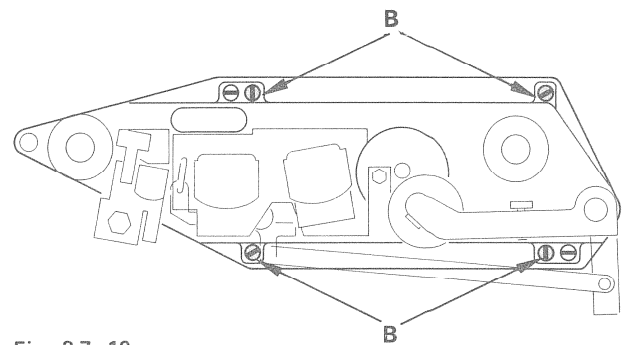

Fig . 3.7-10

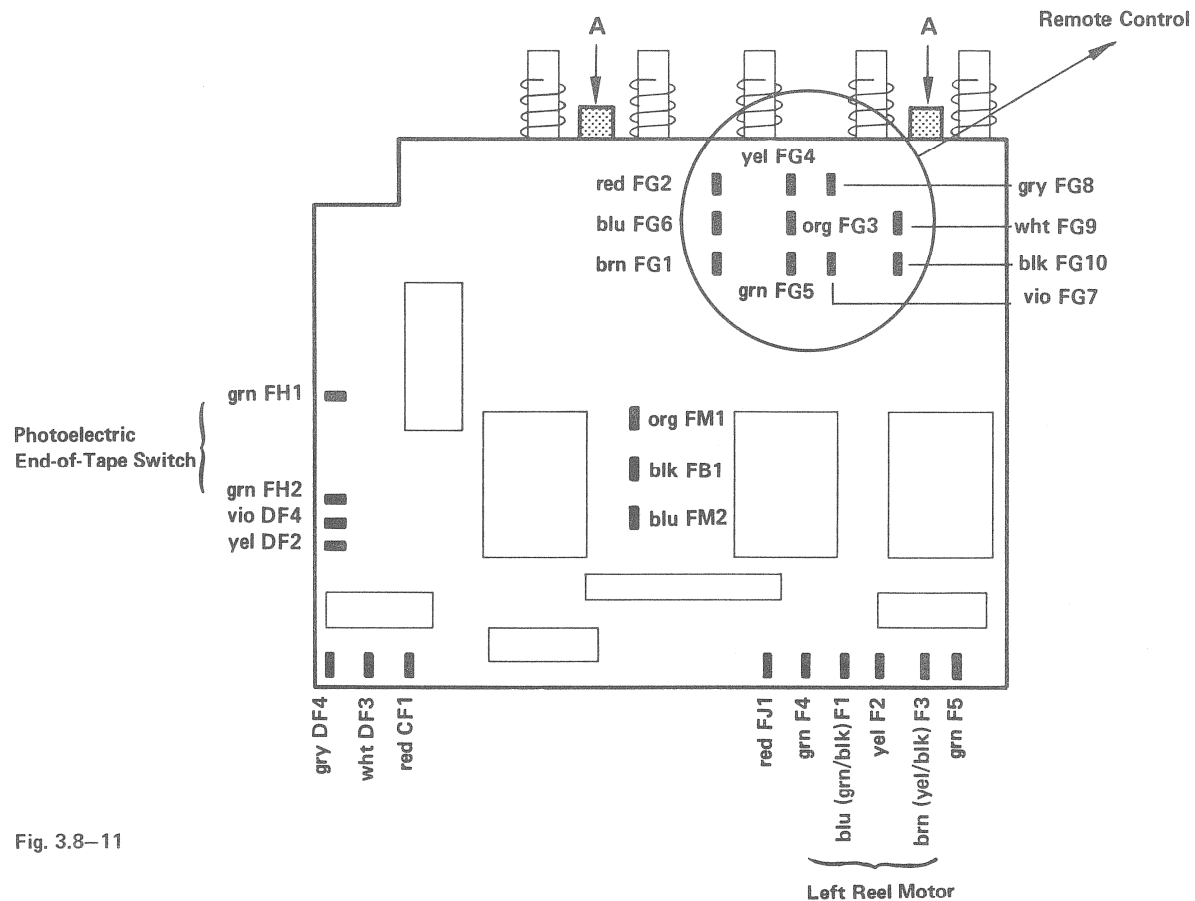

Fig. 3.8-11

3.9. Removal of Power Transformer

- Remove output amplifiers (if present).
- Disconnect brake solenoid cables (unsolder) per fig. 3.5 –6, B.
- Disengage cable to right-hand reel motor on regulator board (fig. 3.6 –7).
- Disengage cable to capstan motor and pick-up on motor control board (fig. 3.7 –9).

Note:

For improved signal to noise performance, the capstan motor connections may be reversed on some recorders in the following manner: E3 = gry, E4 = yel, E5 = grn. Carefully note wire colors before disassembling.

Fig.3.9–12

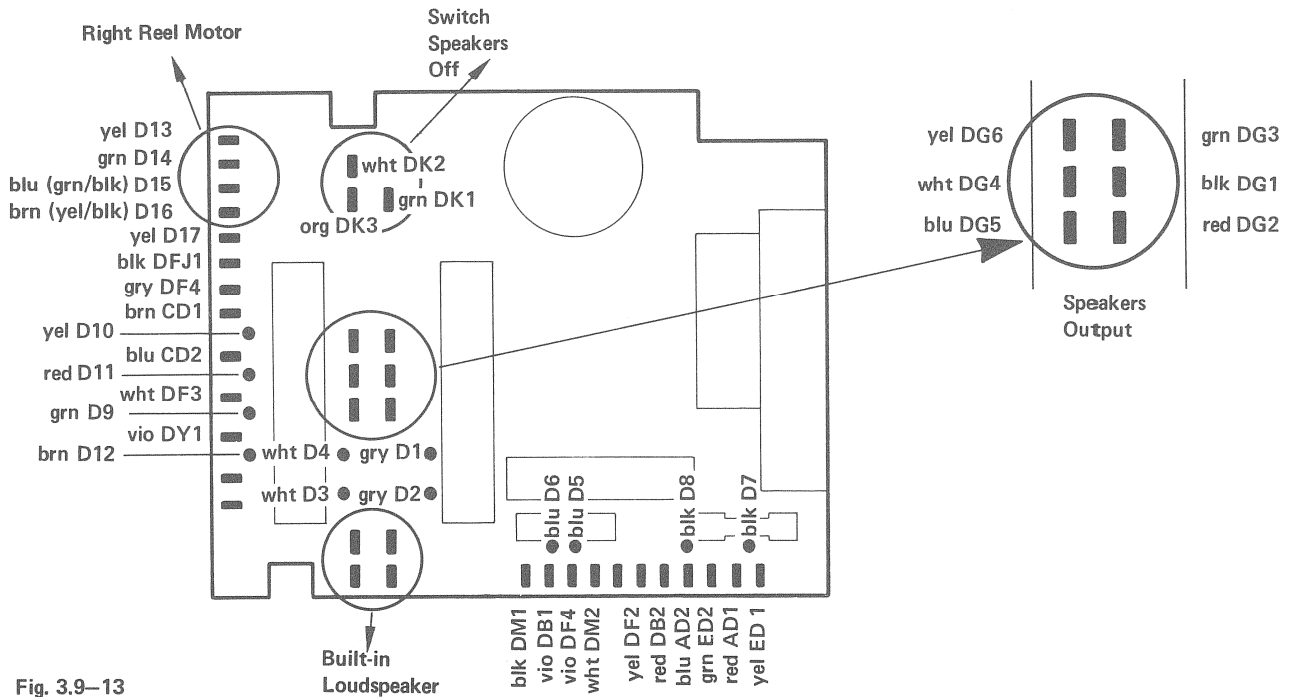
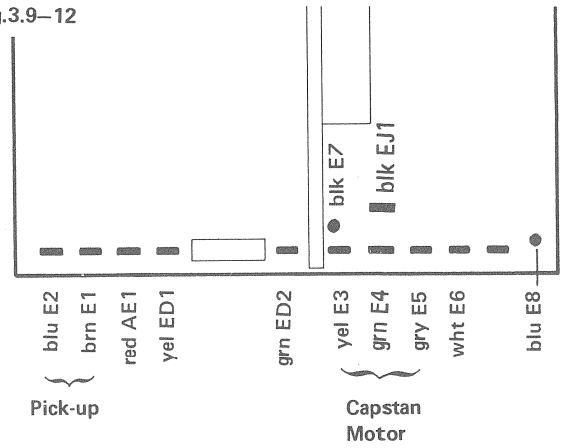

Fig. 3.9–13

- Unscrews transformer fasteners and remove entire assembly carefully downward. Pull off circuit cards and corresponding connectors as needed (fig. 3.9 – 12 and 3.9 – 13).

3.10. Removal of Amplifier Cards

- Mark record and playback amplifiers before removing. The amplifiers have to be reinserted in their respective places to maintain correct level settings.
- Remove cover panel on the front side and pull amplifier cards.

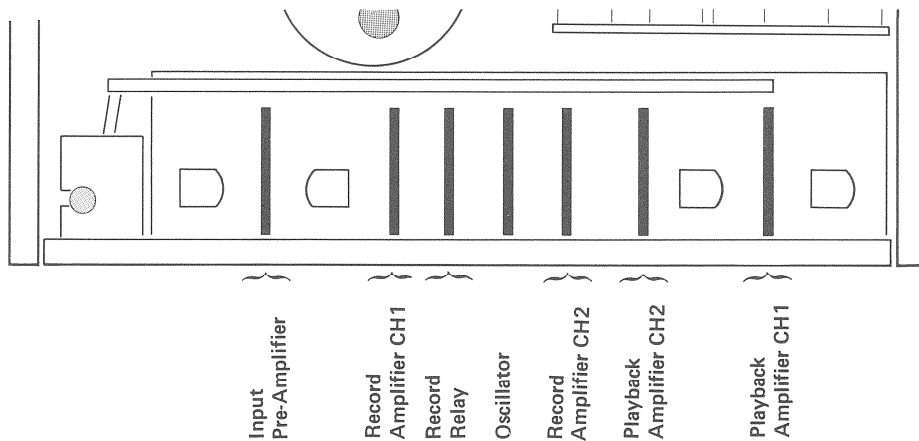

Fig. 3.10–14

3.11. Removal of Potentiometer

- Unsolder wires.
- Unscrew fasteners from below (fig. 3.11 –15)

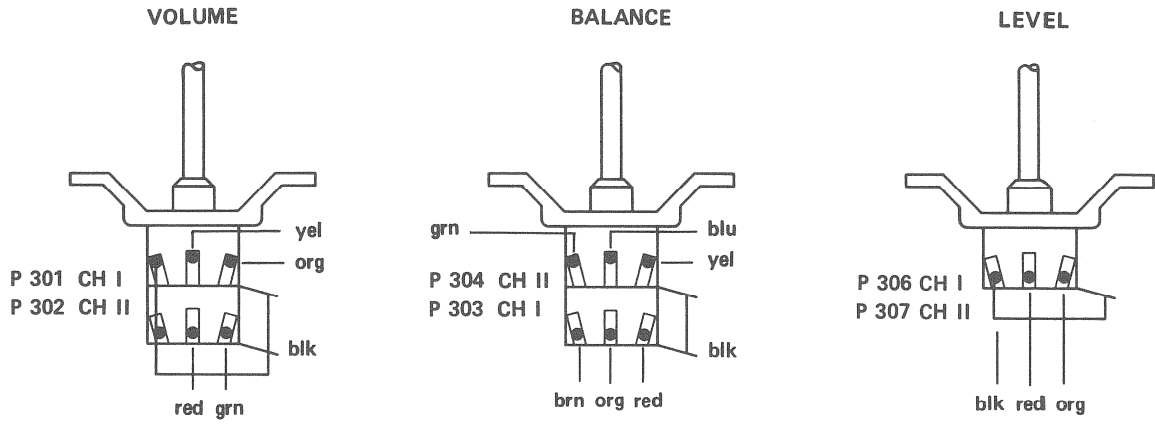

Fig. 3.11–15

3.12. Removal of Switch Board (fig. 3.12 –16)

- Remove plug-in amplifiers (fig. 3.10).
- Remove pusher mechanism (screws A).
- Remove shield (screws B).
- Remove reset spring C (tape lift lever).
- Connectors: disengage headblock-VU-meter board.

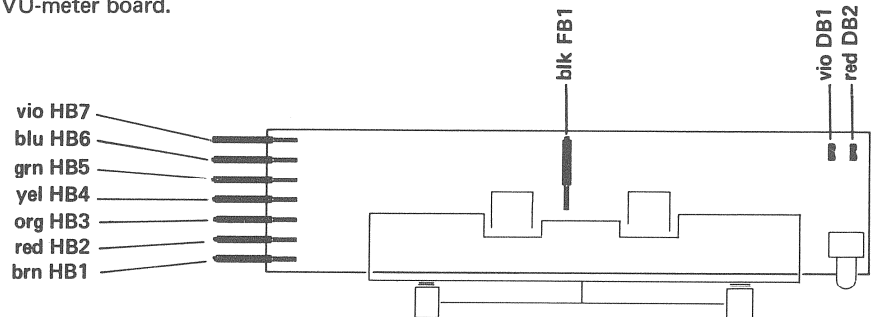
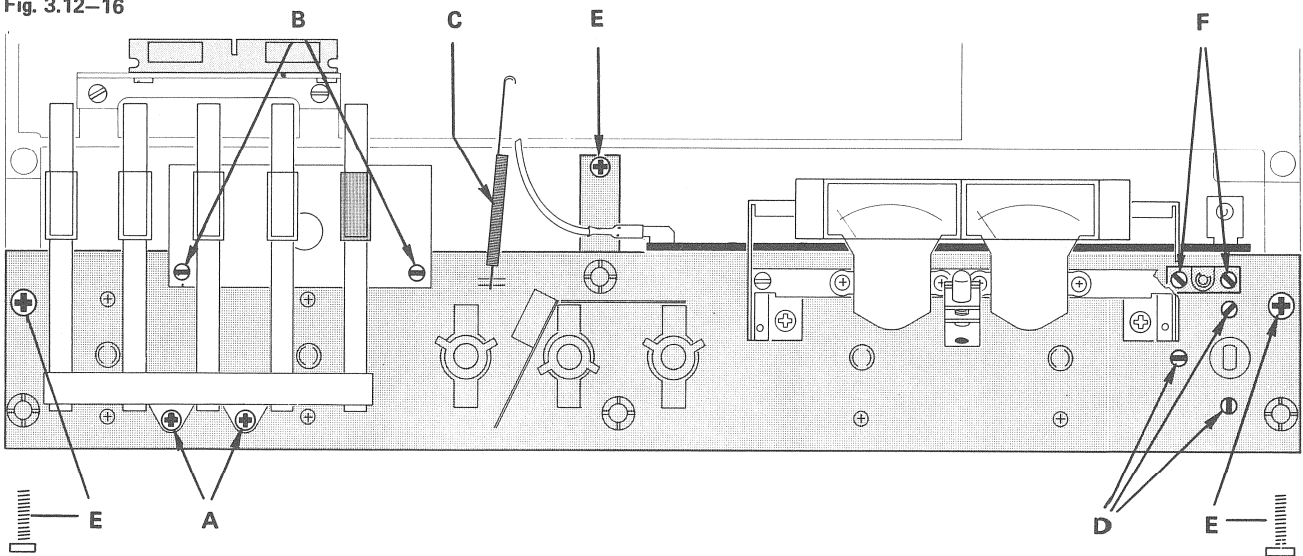

Fig. 3.12–16



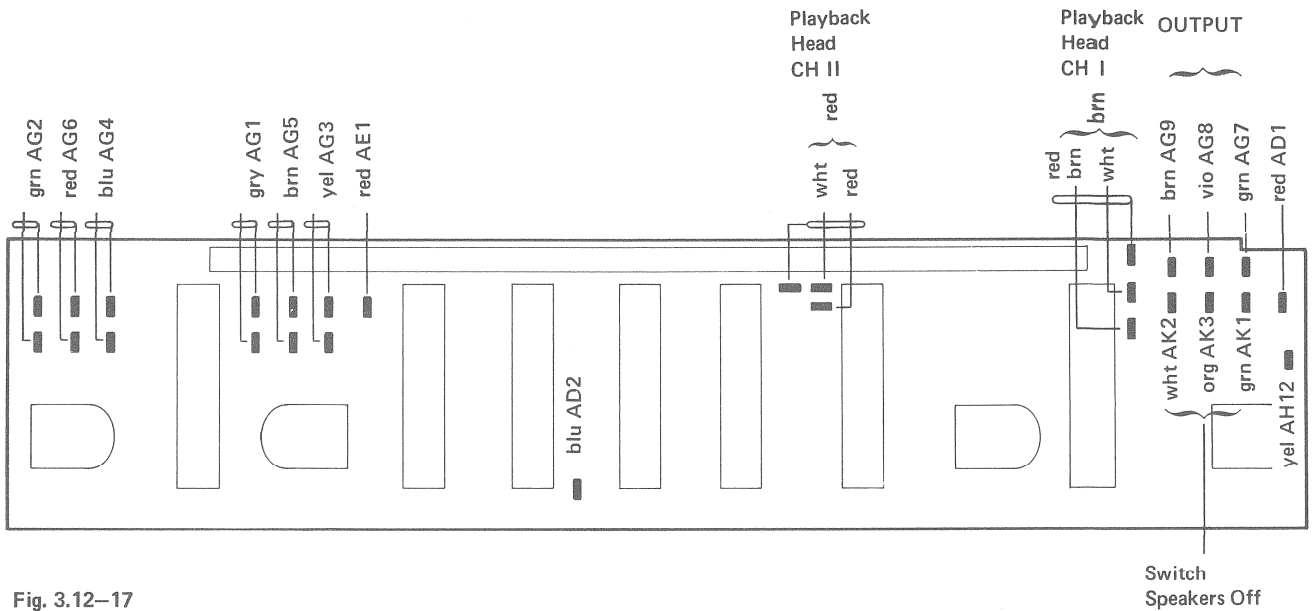

Fig. 3.12-17

- Remove power switch retaining rings and fasteners D. Lower power switch carefully (avoid linkage rod).
- Disconnect all terminals on the switch board (fig. 3.12 -17).
- Unscrews 5 fasteners E (fig. 3.12 -16) and remove complete assembly forward.
- Disengage remaining VU-meter connections.

Position of the equalizing slide switch has to be checked at reassembly. Adjust screws F (fig. 3.12 -16) if necessary (see also 5.1.).

Observe, furthermore, that pressure roller is in rest position (trip lever of playback cut-off contact S 5, left of release lever).

3.13. Removal of Frame (Removal of Rotary Switches)

- Unscrew VU-meter carrier; lift off carefully (observe playback cut-off contact S 5 behind VU-meter board).
- Pull connectors from Jacks. (fig. 3.13-18).
- Unscrew rotary switch fasteners from above. Disconnect ground strap (brown). Remove carrier.

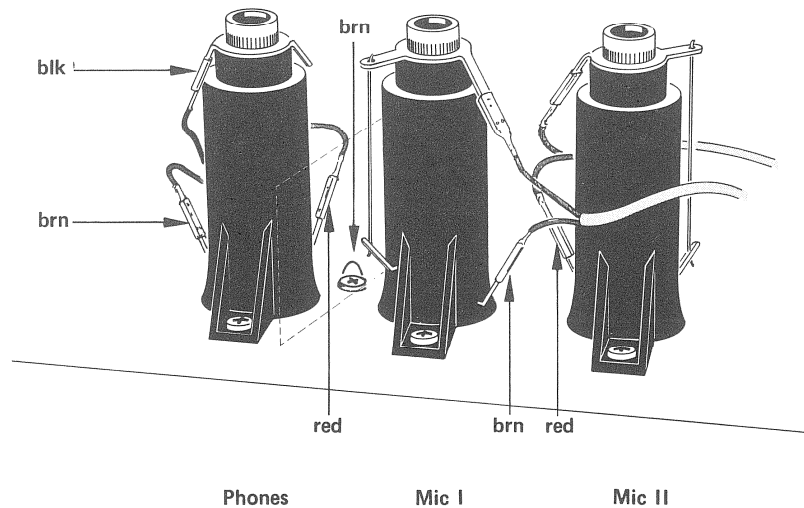

Fig. 3.13-18

4. MECHANICS

The three-motor drive assures almost maintenance-free service of the mechanical section. Adjustments and measurements are limited to the few movable parts.

Special tools needed :

Retaining ring pliers

Spring scales or contactors 200 g (7 oz. av), 2000 g (4.4 lb. av).

4.1. Headblock

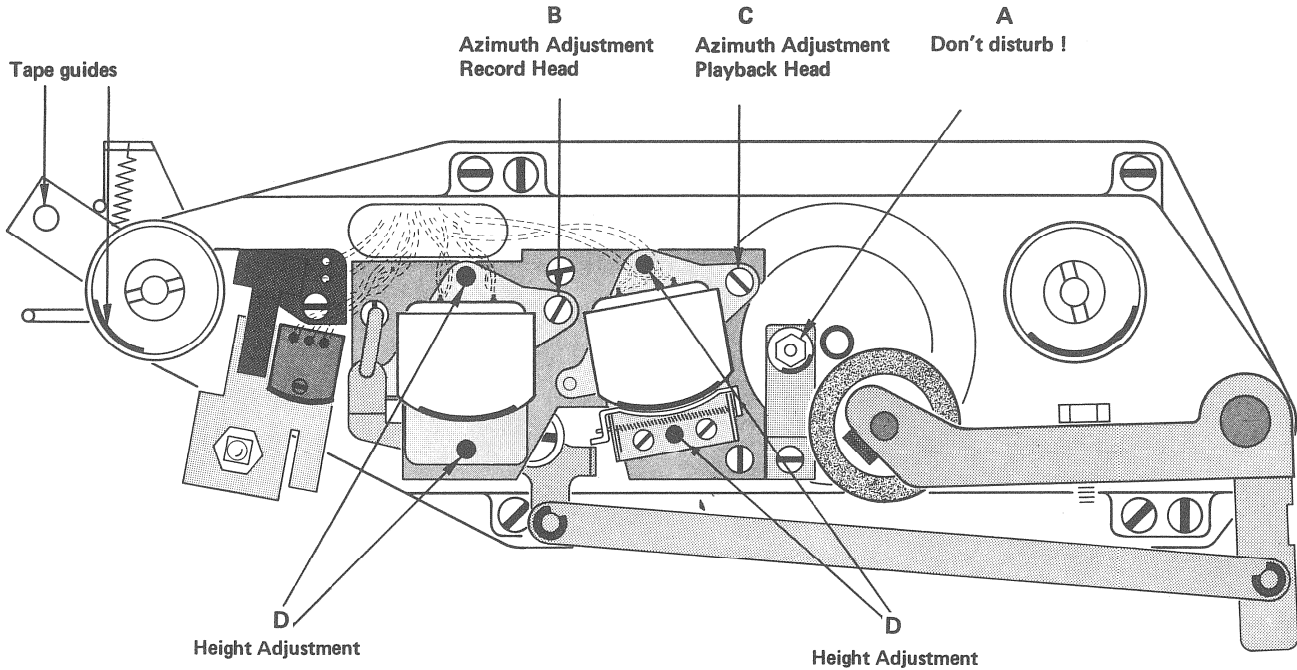

Fig. 4.1-19

4.1.1. Tape guides (fig 4.1 -19)

– Clean tape guides; don't disturb tape guide A ! To remove tape guide A, unscrew only the fastener to the block (near upper end of capstan axis).

4.1.2. Head Mounting (fig. 4.1 -20)

Record and playback heads are mounted on a common base plate which is fastened in turn to the headblock with 3 screws A.

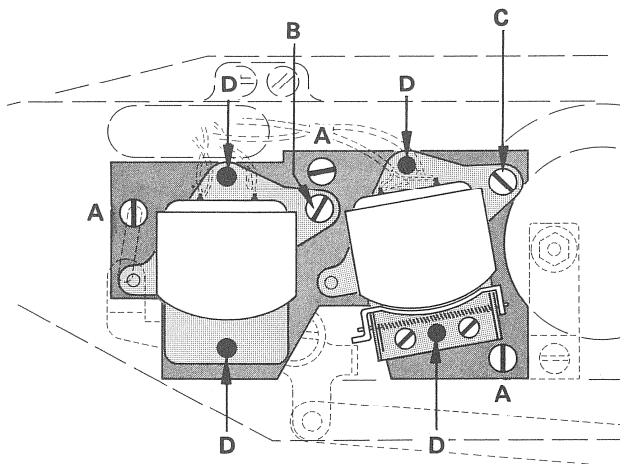
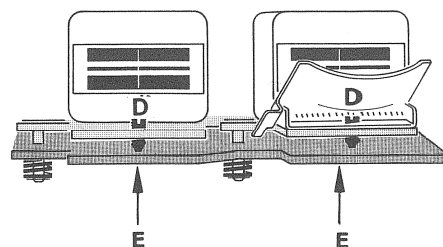

Fig. 4.1-20

Don't disturb setscrews D (height adjustment). The heads can be removed while base plate is off (fastening E).

If height adjustment is required after change, the respective setscrews D are turned by a like amount front and back.

B = Azimuth adjustment, record head (per 6.5.1.)
C = Azimuth adjustment, playback head (per 6.3.1.)



Once adjustments are made on the headblock, the loosened screws must be resecured with lacquer.

Note:

For improved signal to noise performance the connections to both playback head channels may be reversed on some recorders from the wiring shown in Diag. 3, in other words the colored conductors will be soldered to the right-hand terminal. When replacing heads, re-wire in the same manner.

4.2. Tape Tension

- Cover light at the optical end-of-tape switch.
- Measurement values are taken on a core of diameter 115 mm (4,5 '').
- Load and lock empty reel.
- Wind several turns of thread on empty reel and pull thread off slowly in the sense indicated, resulting in the following values:

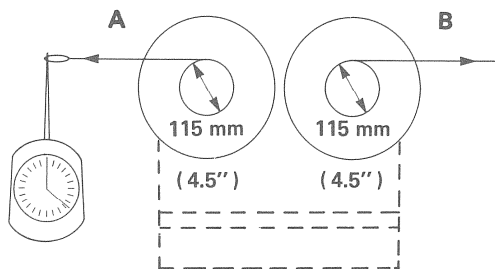

Fig. 4.2-21

Function	7.5 ips or 3.75 ips	A	B
PLAY	tape tension, high	70 gr (2.5 oz.av)	85 gr (3 oz.av)
PLAY	tape tension, low	30 gr (1 oz.av)	50 gr (1.75 oz.av)
<<		210 gr (7.4 oz.av)	about 20 gr (.7 oz.av)
>>		about 20 gr (.7 oz.av)	230 gr (8.1 oz.av)

Table 4.2-22

Check operating voltages of reel motors and phase shift capacitors if these values aren't attained; see table 5.9 -46 and section " Modifications " per 8.1.(Rewind).

4.3. Brakes (Stop)

The stop brakes are effective with solenoid de-energized.
- Push STOP button.

4.3.1. Brake Torque Measurement

Preparation for measurement per 4.2.
Correctly set brakes have following torques:

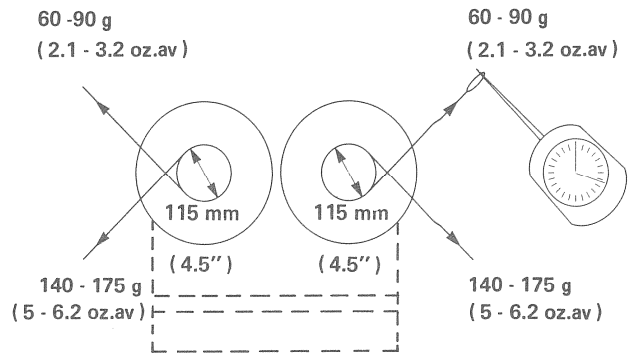

Fig. 4.3-23

4.3.2. Brake Adjustment

Check brake system if above mentioned torques are not reached. Brake linings and bands must be absolutely clean and free of grease. Brake bands must be devoid of kinks and lay up full-width on lining. Details on the modified brake system (brake return spring attached to both ends of the brake-band) are shown on page PL 7a of the parts list. Brake mechanism and solenoid stroke are reset after exchanging band and/or linings.

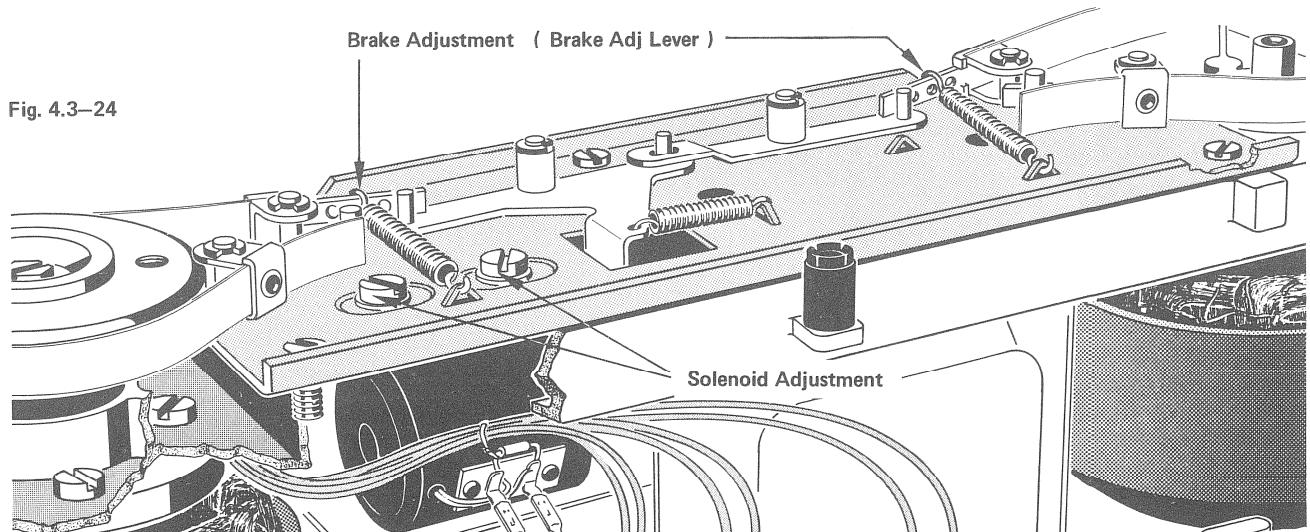

Fig. 4.3-24

- Loosen brake manually (push in solenoid core).
- Check if both brakes clear simultaneously; if not unscrew the 3 chassis fasteners partly, slide chassis around till both bands are clear.
- If necessary, bend one brake adjustment lever.

The solenoid has to be energized for adjustment.

- Cover light at the optical end-of-tape switch.
- Depress " Reel Motors off " (42), depress button << (fast rewind).
- Loosen fastening of solenoid and reset so that the bands clear rollers by from .1 -.2 mm (.040 " to .080 ")
- Secure solenoid during this adjustment. Braking torque can be varied by hooking springs at different places on the brake adjustment lever.

4.4. Pressure Roller

The pressure lever is actuated electromechanically. Pressure is set by the variable spring force (fig. 4.4 -25).

4.4.1. Pressure Measurement

- Load tape with 1 kHz record.
- Switch on PLAY.
- Tie nylon thread to pressure roller axis (or to a pin affixed thereto) and pull with a spring scale (or contactor) in sense A till sound volume drops noticeably.
- **The spring scale must show 1.5 kg (3.3 lb.av).**
- Screw C sets pressure force.

4.4.2. Pressure Solenoid Readjustment

- Switch instrument to PLAY. If no tape is loaded, cover light at optical end-of-tape switch.
- Slide pressure solenoid to the right gap B (fig. 4.4-25) is .3 mm (.012 ")
- Block pressure solenoid.
- Check if solenoid core is in end position. The core shall not move if the lever is pulled slightly from the capstan axis.
- Secure fasteners of solenoid with a drop of lacquer.
- Check pressure, reset screw C if necessary.

4.4.3. Exchange of Pressure Roller

- Hold pressure roller axis at groove from above (fig. 4.4 -25) and remove bolt fastening E to the side.
- Pull pressure roller axis up and roller to the side. Reassembly is explained in the replacement parts list.

Make sure that no cleaning fluid gets to the sintered bearing while cleaning the roller.

4.4.4. Pressure Lever Readjustment

After exchanging the pressure lever, it is necessary to readjust it with respect to lever F (fig. 4.4 -25). When the lever is stopped (solenoid core fully out), the distance between capstan axis and pressure roller shall be 10 mm (.4 ").

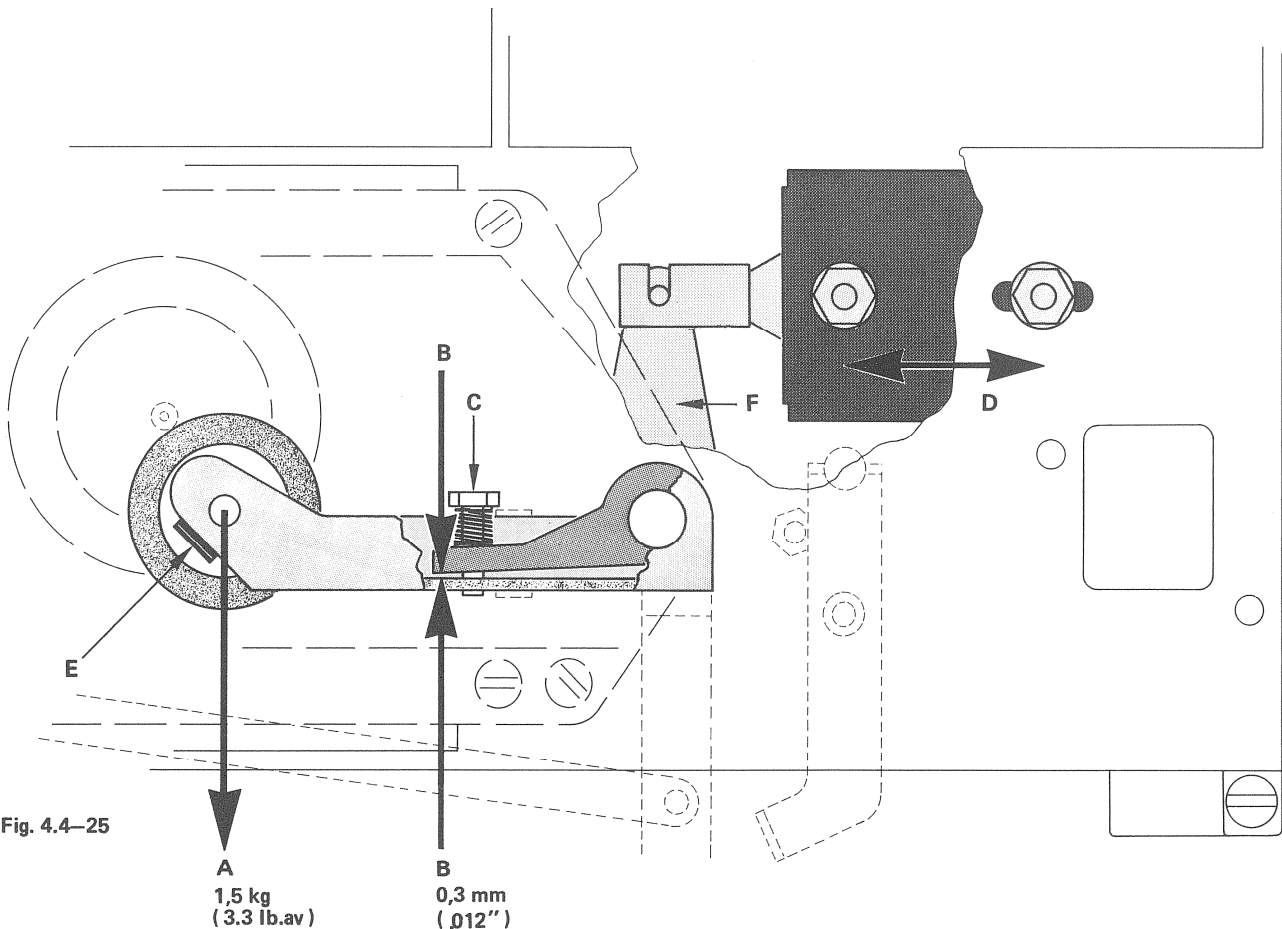

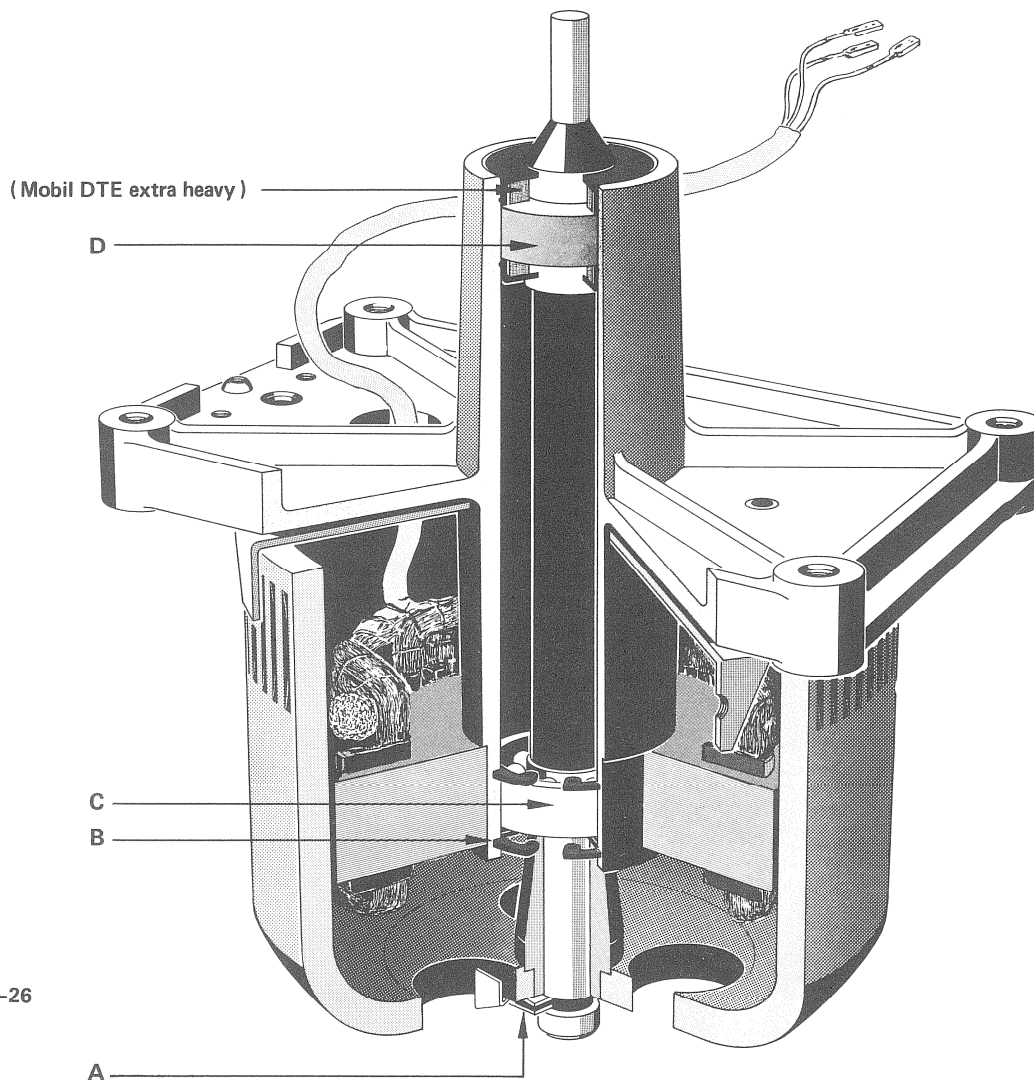

Fig. 4.5-26

ATTENTION

Capstan Motor with Sleeve Bearings

Modification effective from

serial Nr. S 60483

G 78003

see section 8.6./page 35

4.5. Capstan Motor (with Ball Bearing) Fig. 4.5.-26

(Control circuitry see 5.10 & 6.2.)

The capstan axis goes completely through the motor. It is held by a sintered bronze bearing (D) and below by a ball bearing. Both bearings are lubricated for their life and should normally require no service. Capstan axis and ball bearing can be exchanged very easily. A defective sintered bearing is to be sent to the nearest factory representative. (Disassembly see para 3.7.)

4.5.1. Removal of Capstan Axis, Ball Bearings

The capstan motor need not be removed to get axis and bearing out.

- Unfasten securing clip A. Lower capstan rotor.
- The axis can be taken out through the top if the tape guide between playback head and capstan axis has been screwed off (don't disturb guide setting).
- If the retaining ring B is removed, the capstan axis can be lowered with bearing C.

Bearing C is a special tight tolerance part and shall be exchanged only with an **original bearing**.

Special care must be taken with handling the capstan axis and bearings to avoid damage or entry of dust into the precision parts (run-out better than 1/1000 mm = 40 micro - inch !).

Instructions for installation of the new no-turn device A in conjunction with old rotors are given on page PL 9 of the parts list.

4.6. Exchange of Reel Motor Bearings

- Remove reel motor per 3.6.
- Remove brass sleeve A. Open clip B and retaining ring C with retaining pliers, open only wide enough to pull them away. Lower rotor with axis out of motor frame.

The bellville springs (see parts list PL 8) remain on the shaft.

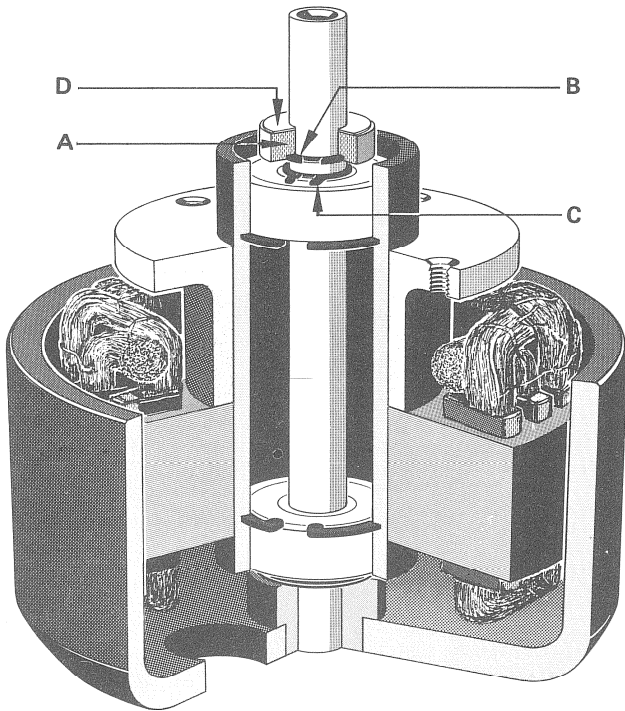

Fig. 4.5-27

In addition to sleeves A there are washers D for height adjustment of the brake drum (reel plate). Be sure to put these parts on the same motor axis at assembly.

The reel motor ball bearings shall exchanged only with original bearings.

4.7. Lubrication

All bearings are lubricated for their life and should normally require no service. They shall be exchanged only with original bearings, in case of malfunction. If the capstan axis is exchanged, the upper felt washer of sintered bearing D (fig. 4.5 -26) is to be lubricated with some drops MOBIL DTE extra heavy.

4.8. End-of-Tape Switch (Operation: per 5.9.1.)

The light source of the optical end-of-tape switch can be removed by lifting it upward.

5. ELECTRONICS

The electronic circuitry is divided into groups, plug-in modules for the most part. There are etched circuit card plug-in modules for :

- Input amplifier, record amplifier, playback amplifier, oscillator, and record relay.
- Output amplifier.

There are several etched circuit boards, rigidly mounted but with plug-on connectors for:

- Regulator
- Drive control with photoelectric end-of-tape switch.
- Capstan motor control.

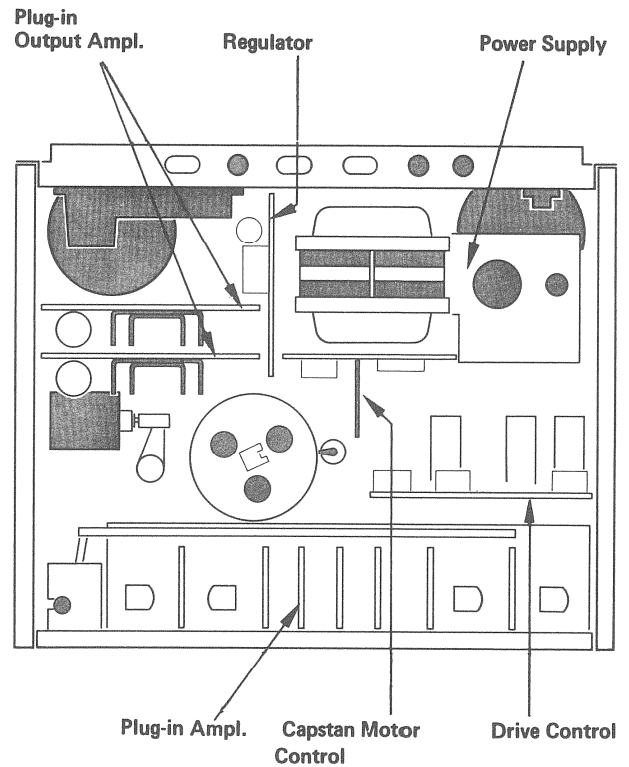

Fig. 5.-28

Block Diagram (Amplifiers)

The block diagram shows the relationships between the plug-in amplifiers.

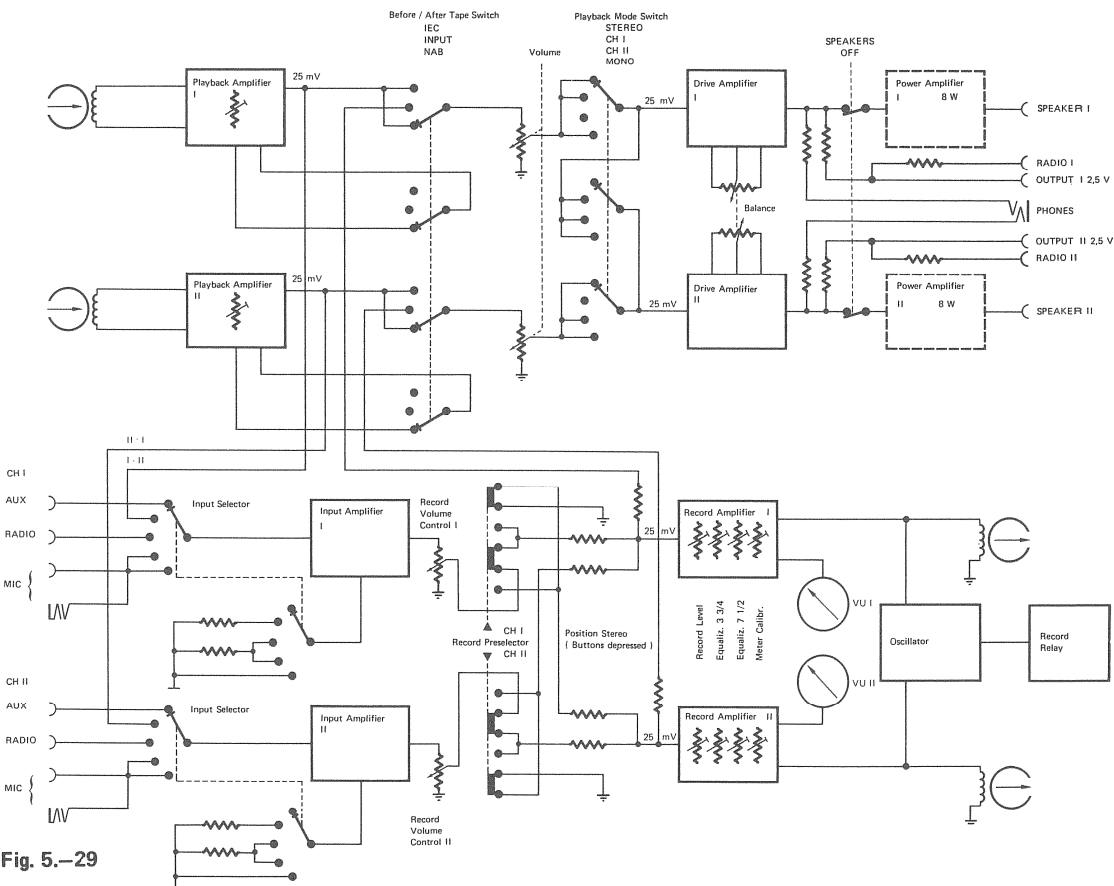

Fig. 5.-29

5.1. Switch Board and VU-Meter Board

(Diagram No. 1.077.435 & 1.077.480)

(Removal per 3.12)

The switch board carries plug-in amplifiers (without output amplifiers), control switches and potentiometers for inputs, balance and volume. The shielded inputs can be plugged on the switch board (below, left-hand). Inputs for playback amplifiers as well as outputs for OUTPUT and output amplifiers can also be plugged in (right-hand).

The equalization slide switch is controled through the power switch. It has to be readjusted in case of exchange. This is done with screws F (fig. 3.12 –16).

The switch terminal contact areas for input selector, before-and-after tape switch, and playback functions are printed directly on the board. The rotary switches are encased and indexed against misorientation. Check fig. 5.1 –32. for case and contact configurations. Assembly information is in the spare parts list.

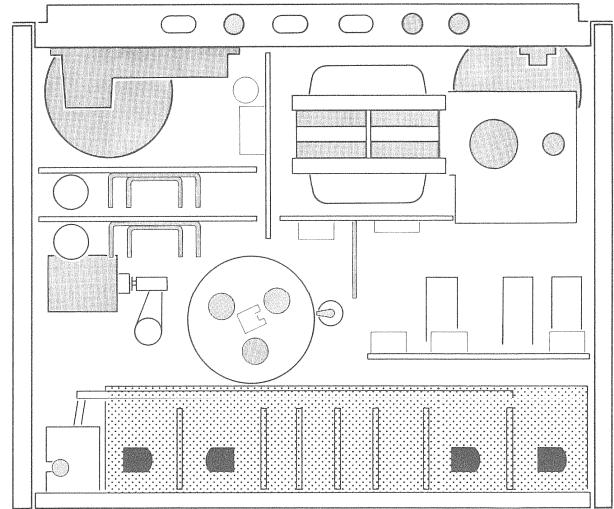

Fig. 5.1–30

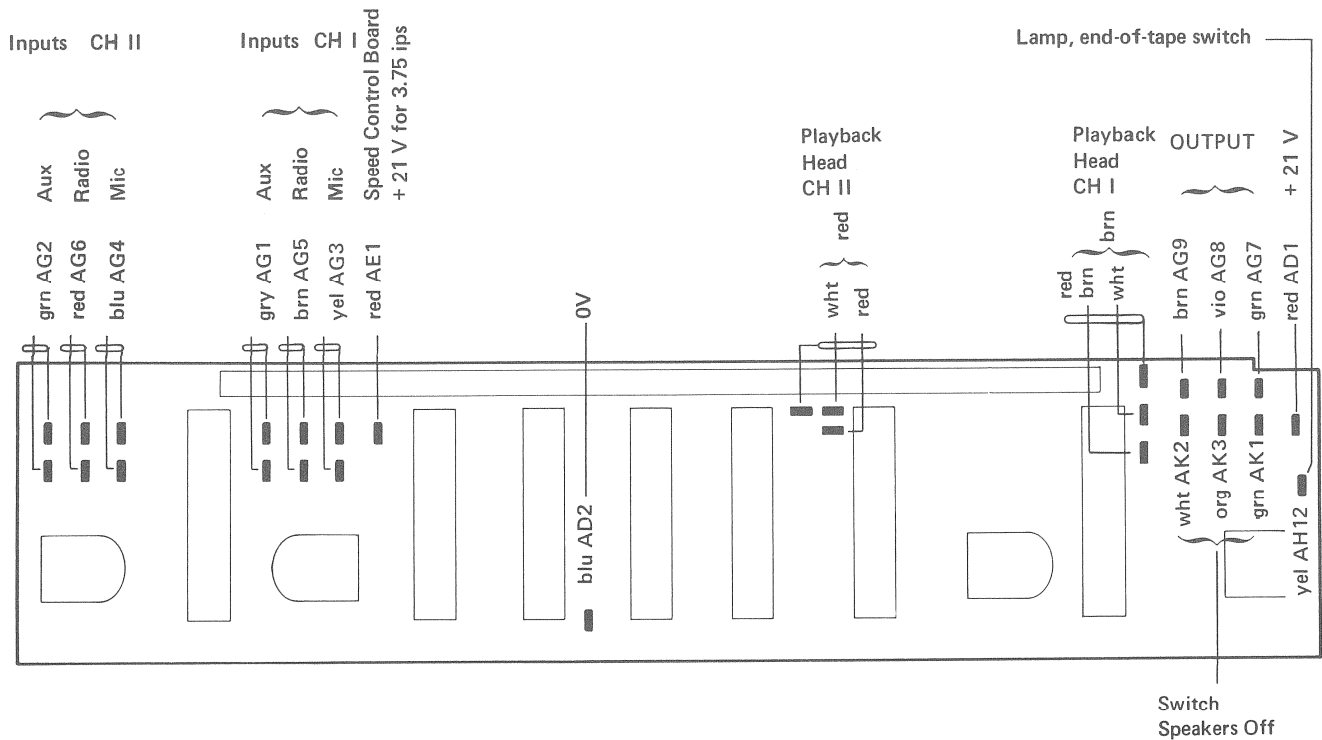

Fig. 5.1–31

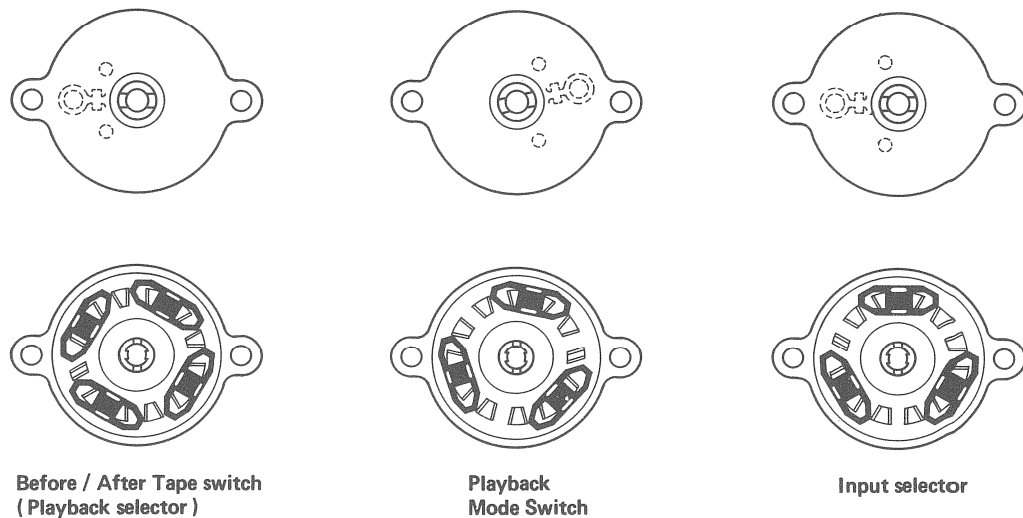

Fig. 5.1-32

The VU-meter board is linked to the switch board by connectors. It carries the preselector buttons for CH 1 and CH 2; they switch the record-erase signals. (Note that the audio signal has to be switched inversely on the record amplifier when neither button is depressed !)

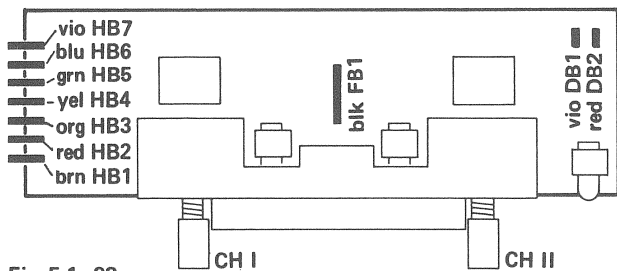

Fig. 5.1-33

Resistor R 406 / R 426 (100K) is bridged or reduced by parallel resistors for this purpose. If R 406 / R 426 is shorted, amplification of the whole stage is $A = 460$ approx with 1K in parallel $A = 20$ approx, and without parallel resistor $A = 1.2$ approximately. Parallel resistors R 316 / R 317 (CH 1) and R 321 / R 322 (CH 2) are on switch board 1.077.435. The output stage configuration has the advantage that the supply voltage can be fully modulated. Output voltage is nominally 50 mVac, but it can deliver up to 6 Vac undistorted.

This corresponds to an overmodulation stability of more than 40 dB. Aside from the overmodulation stability, sensitivity matching of the input stage through feedback has the advantage in that input noise is not worsened by the series-connected voltage divider.

5.2. Input Amplifier (1.077.700)

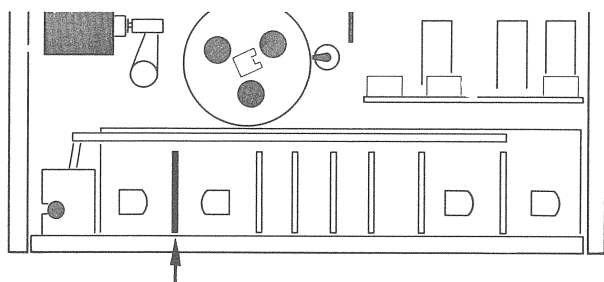

Fig. 5.2-34

5.3. Record Amplifier (1.077.705)

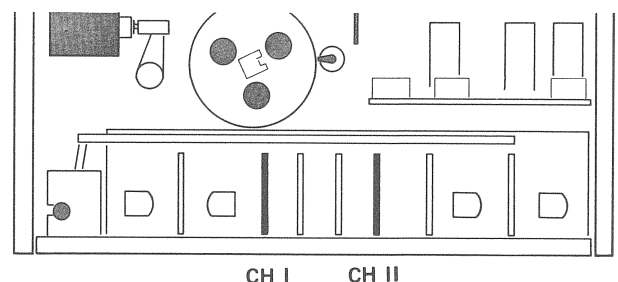

Fig. 5.3-35

The input amplifier card contains the pre-amplifiers for both channels.

Input sensitivity is matched through a stepped variable feedback (d.c. feedback fixed) at the signal source voltages AUXILIARY (35 mV), track transfer (8 mV), RADIO (2,5 mV), MICROPHONE high (2,5 mV), MICROPHONE low (.15 mV).

The record amplifier cards contain an equalization pre-amplifier (Q 501, Q 502), a VU-meter amplifier (503), and a driver amplifier (Q 504, Q 505). At the input of the equalization pre-amplifier is a bus voltage level of about 25 mV (at 1 kHz and nominal input signal, record regulator fully opened).

Recording is equalized per NAB standard. Lows equalization (3180 μ sec) is accomplished by feedback through series-connected C 504 and trimpotometers P 501 and P 502. Highs equalization can be set separately for both speeds; P 502 for 7.5ips, P501 for 3.75ips.

Trimpot P 503 serves for voltage balance. The driver amplifiers are laid out for high overmodulation stability. Transistor Q 505 supplies the necessary collector d.c. to Q 504 for modulation.

Q 505 represents high impedance for AF which furnishes the entire output a.c. for modulating the record head. Modulation reserve is better than 15 dB. A tank circuit with a resonant frequency of 38 kHz causes current depending feedback in the emitter circuit of the driver stage (L 502 / C 514) for pilot carrier remainders which could interfere with the erase frequency. Between the decoupling point and record head is another tank circuit for the bias of 120 kHz (L 501 / C 517). The decoupling point is shorted by the record relay during playback.

Amplification of the VU-meter stage can be calibrated on P 504.

To protect the VU-meter indicators against RFI (radio frequency interference), resulting in misindication, the stage is decoupled for RF with C 508.

5.4. Oscillator (1.077.710)

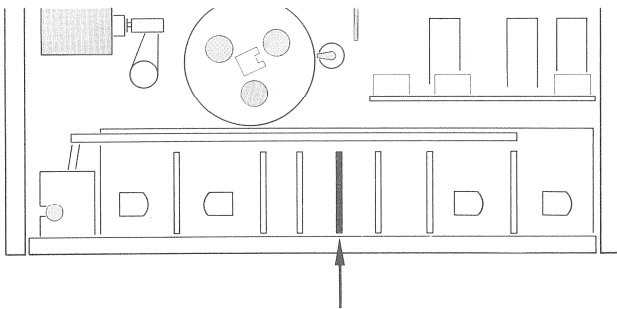

Fig. 5.4-36

The push-pull collector circuit guarantees minimum odd harmonics. Symmetry of sinusoidal waves is assured and interfering d.c. components can't arise. Erase and bias of 120 kHz is high enough to prevent their interfering. The erase frequency is symmetrically decoupled. In mono-operation, load is held constant by the compensation coil (para 5.5.) which proves advantageous for voltage and frequency stability.

Bias current can be set with trimpots P 707 to P 710 separately for CH 1 and CH 2 as well as for both tape speeds.

5.5. Record Relay (1.077.715)

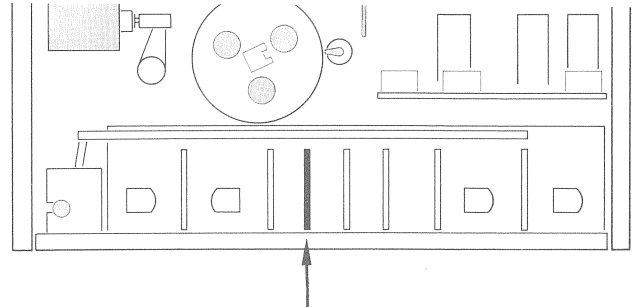

Fig. 5.5-37

Purpose of the record relay with an electronic switch is to turn on the oscillator " softly ". To get an integral curve of the switching voltage, Q 601 (switching transistor) is delayed by an RC - network (R 603, C 602).

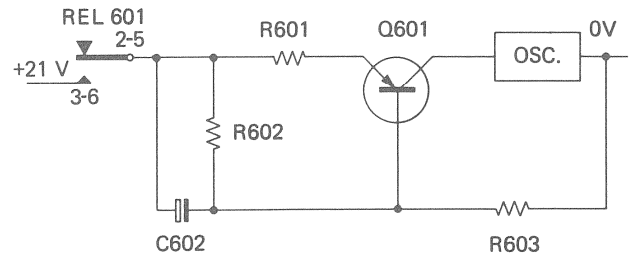

Fig. 5.5.-38

C 602 is discharged at the start and the base of Q 601 is at 0V. If contacts 2/3, 5/6 of record relay REL 601 close, bias voltage rises with the charge on C 602 till saturation. When contacts 2/3, 5/6 open, C 602 discharges over R 602.

The head compensation coil has two winding halves acting as dummy load for the inactive half of the erase head during mono-operation. The compensation coil balances out inductive strays of the erase head.

Resistor R 604 corrects Q - factor and assures minimum voltage jump between monaural and binaural operation (exchange of erase head may require resetting).

5.6. Playback Amplifier (1.077.720)

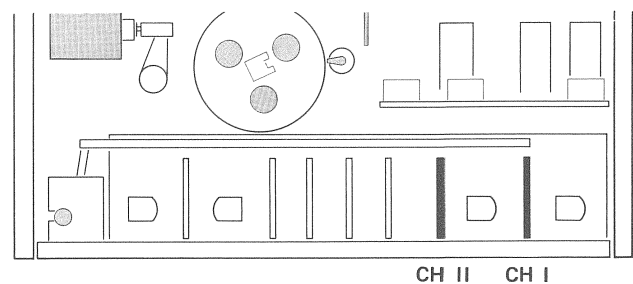

Fig. 5.6-39

Playback amplifier cards each contain one playback (pre-) amplifier and one drive amplifier. The playback head is d.c. coupled to the input stage (Q 801). D.c. feedback from the emitter voltage divider of stage (Q 802) goes over the playback head to base (Q 801) and stabilizes its quiescent point. The feedback current is less than 1 μ A which avoids magnetization of the playback head. AF-components of the feedback are shunted through C 803. Its capacitive resistance becomes effective at very low frequencies (less than 20 Hz) so that these frequencies are fed back. Playback equalization is switchable NAB - IEC (CCIR). The equalization circuit is in the feedback branch collector Q 802 / emitter Q 801. The RC-member R 808 / C 805 / takes care of the lows equalization (3180 μ sec).

Basic time constants of equalization are obtained by shorting the partial resistors of the circuit. For :

7.5 ips	NAB	(50 μ sec)	3 - 4 - 5
	IEC	(70 μ sec)	3 - 4
3.75 ips	NAB / IEC	(90 μ sec)	4 - 5

At the pre-stage exit is a 120 kHz tank circuit for the bias frequency and trimpot P 801 for setting the level of the bus voltage. The signal is conducted over the before- and - after - tape switch, volume control, and playback mode switch (channel selector) to the drive amplifier.

The drive amplifier is three-stage d.c. coupled. It amplifies the signal to the level of the terminals OUTPUT, headphones, as well as for the modulation of the plug-in power amplifiers. D.c. feedback, emitter voltage divider Q 804 / base Q 803 stabilizes the quiescent points of all three stages. Balance regulation is accomplished with potentiometers P 303, P 304 (coupled) in feedback branch emitter Q 805 / emitter Q 803.

In STOP position, when the pressure lever is at rest, output of the playback pre-amplifier (13) is shorted through contact S 5 (switch board 1.077.435).

The power amplifier cards have separate rectifiers and filters for each channel. The power transformer has two separate windings (32 Vac) for the power amplifiers. The entire amplifier is d.c. coupled and works with a single-ended push-pull output stage. The loudspeaker is, practically free of d.c., in the diagonal of a bridge formed by Q 905 and Q 906 as well as the electrolytic capacitors C 907 and C 908. Q 901 and Q 902 operate as voltage amplifiers.

Series connected D 901, R 911, D 902 are used to keep the no-load current of the output transistors constant, independent of temperature. By strong d.c. depending feedback (100 %), collector Q 906 emitter Q 901, the zero point of the loudspeaker output is held constant. AF-amplification is set by the voltage ratio R 905 to R 906.

5.3. Power Supply

(Diagram Tape Drive 1.077.100, No. 1.077.540)

(Removal, per 3.9.)

Both lines of the power supply can be switched off (Micro-Switches). In addition there are two break-contacts which disconnect upon removal of the housing. The sectional tape core power transformer has five windings for following units :

Capstan and reel motors:	130 Vac (150 Vac)	with 4 taps
Relay control :	22 Vac	(supply voltage 27 Vdc)
Amplifier supply :	24 Vac	(supply voltage 21 Vdc, regulated)
Output amplifier :	32 Vac	(CH 1)
Output amplifier :	32 Vac	(CH 2)

5.7. Power Amplifier (1.077.850)

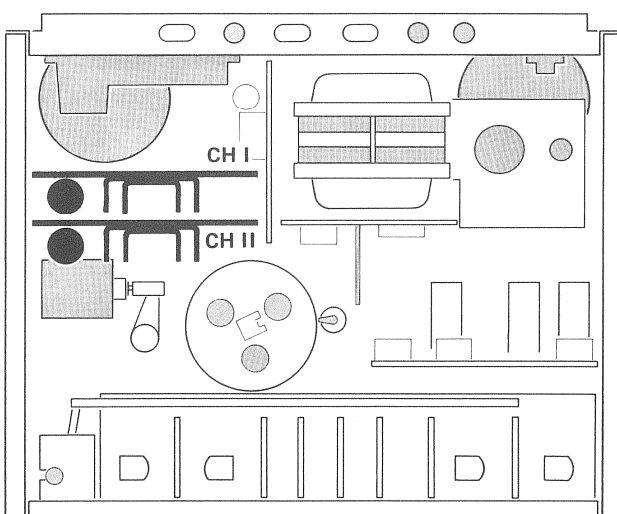

Fig. 5.7-40

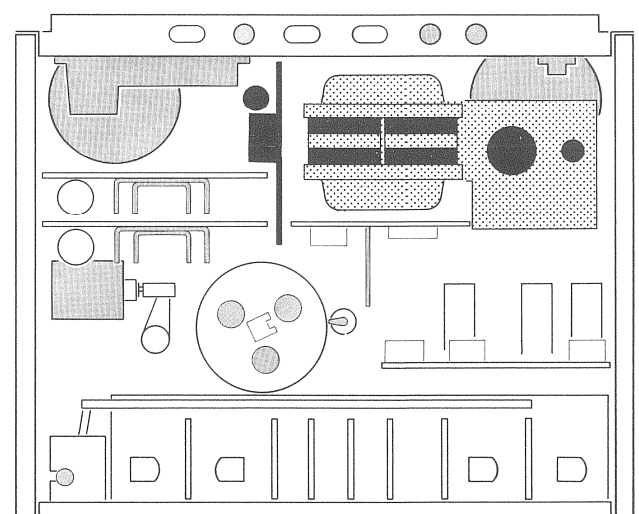

Fig. 5.8-41

Power supply board 1.077.540 carries the output amplifier connectors.

The electronically regulated voltage (21 V) for amplifiers (and oscillator) is adjusted at P 106. The transistor Q 102 acts as a series regulator, whose conductivity is controlled by Q 101. The zenerdiode D 104 provides a 12 V reference for the emitter of this latter transistor.

Diode D 103 protects the base-emitter diode of transistor Q 101 from overload in case of possible short circuit in the amplifier section.

5.9. Drive Control

(1.077.370, Diagram Tape Drive 1.077.100)

(Removal per 3.8.)

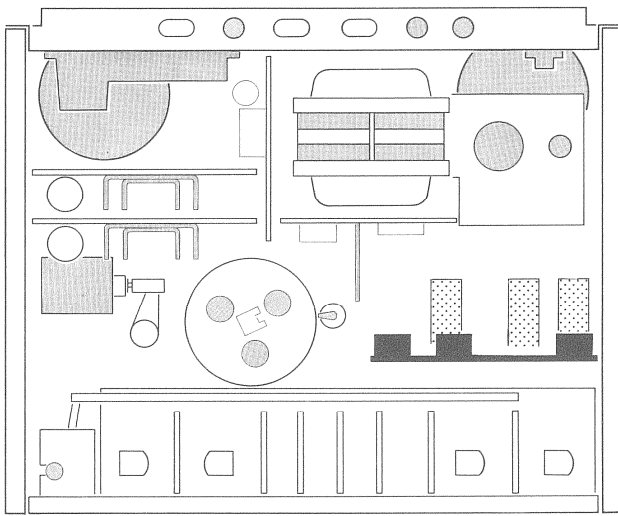

Fig. 5.9-42

The drive push buttons operate contacts on control board 1.077.370. Remote control contacts can be paralleled to these contacts (remote control contacts F3 to F10). To have a minimum of relays, their control is locked by diodes. The principle of their control is explained by an example for better understanding. In the circuit of fig. 5.9-43, relay A is energized and contact a 8/12 (self-holding) is closed. This corresponds to mode PLAY. Relay B is without current, contact b 6/10 is open.

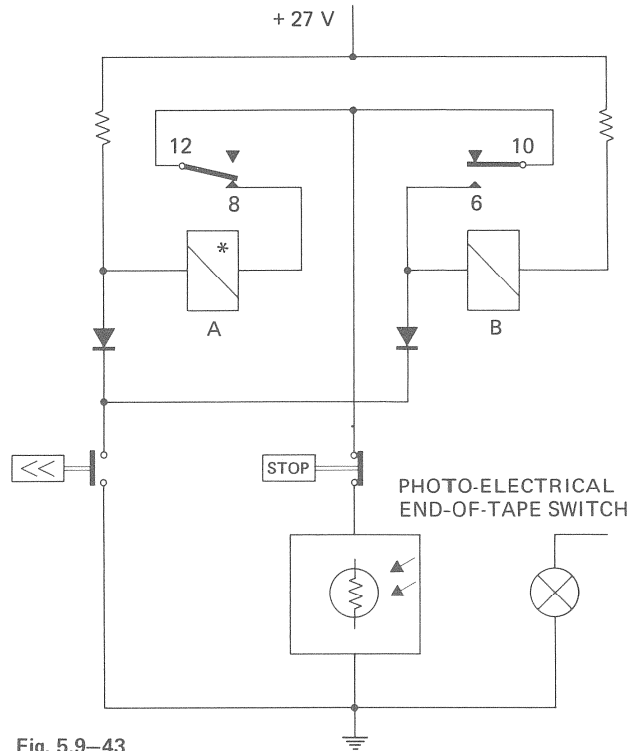

Fig. 5.9-43

If button << is depressed, relay A is shorted and drops off. Simultaneously relay B is energized and holds itself over self-holding contact b 6/10. Self-holding can be interrupted by the STOP button or by the photoelectric end-of-tape switch. The following table indicates which relays and solenoids are energized for corresponding functions.

Table 5.9-44

	A	B	C	Record Relay	Roller Solenoid	Brake Solenoid
STOP						
PLAY	x				x	x
>>			x			x
<<		x				x
REC	x	x		x	x	x

To avoid loose tape loops at record and playback starts, the right-hand reel motor receives elevated voltage for about 0.3 sec (winding reversal voltage 105 V). Relay C must be energized a short period for this, accomplished by the following circuit :

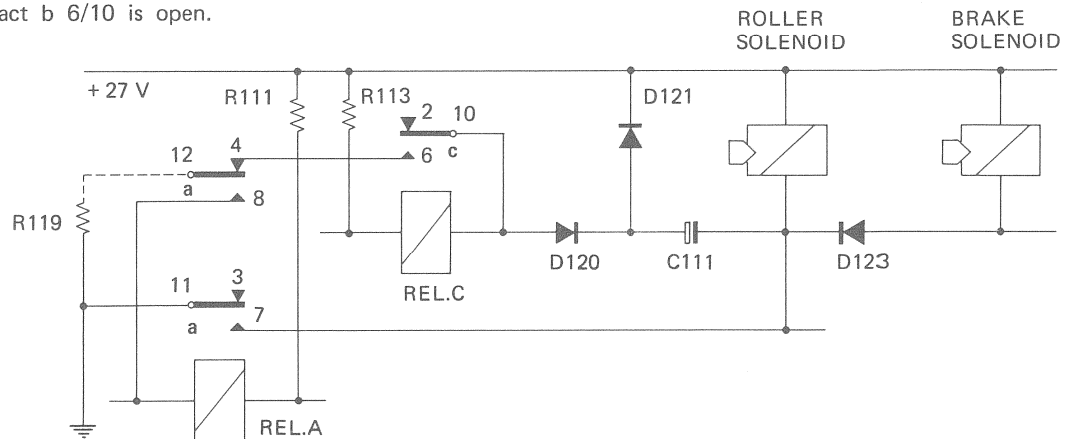

Fig. 5.9-45

If the instrument is in the STOP mode, relay A is without current and contacts a 12 and a 11 are in rest position (fig. 5.9 –45). If relay A is energized (PLAY mode), it will hold over self-holding contact a 8/12. Contact a 7/11 closes. A charging current to capacitor C 111 flows over the relay. This energizes relay C and switches the right-hand reel motor to 105 V over contact c 5/9 (self-holding relay C is interrupted by contact a 12). The charging current falls with increasing charge on C 111 and relay C drops off. When switching back to STOP mode, contact a 7/11 opens and capacitor C 111 discharges over the windings of brake and roller solenoids.

The following table summarizes motor voltages for the drive modes.





Mode	Motor Voltages in Vac			
	Rewind Motor		Winding Motor	
PLAY/REC	 55-6 = 49	 42-6 = 36	 55	 42
>>	21		105	
<<	99		15	

Table 5.9–46

5.9.1. Photoelectric End-of-Tape Switch

The working current loop of the relays is closed over the self-holding contacts, the STOP button and the collector-emitter path of switching transistor Q 112. Triggering the end-of-tape switch (Schmitt-trigger) does the same thing as depressing the STOP button.

As soon as light falls on photoelement R 155, its resistance drops and base voltage at Q 111 rises. Collector voltage at Q 111 drops and cuts off Q 112.

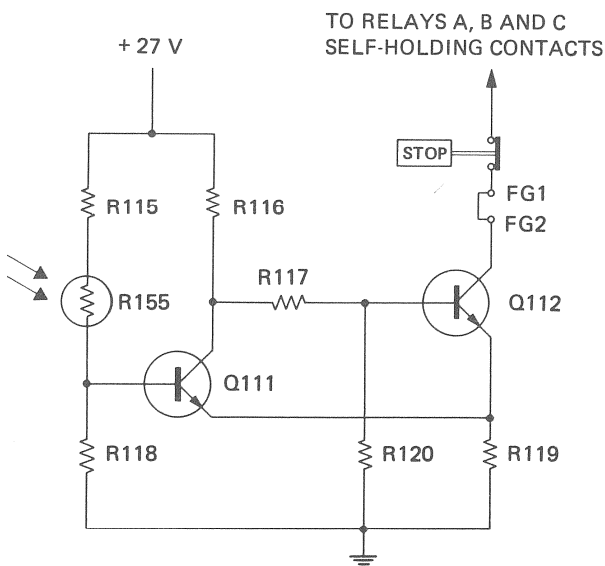

Fig. 5.9.–47

The process is accelerated by the falling emitter voltage on R 119 (feedback), so that a pulse-type transient occurs despite the gliding resistance change of R 155 (sensitivity inertia).

The trigger conditions light - dark, generate the following voltages at collector Q 111: light, 1 V; dark about 22 V. To check the photoresistor, for light and dark values, it must be disconnected from the circuit. Connections FH1 / FH2 (green) on switch board (fig. 3.8 –11) have to be pulled for this. The resistances are: light, less than 2 kOhm; dark more than 20 kOhm.

(Don't solder at the soldering terminal of the photoresistor , it is heat sensitive).

5.10. Speed Regulation, Capstan Motor (7.077.725)

(Removal per 3.9.)

The electronically regulated tape drive of REVOX A77 uses a method unknown so far in tape recording. That is why this technology of regulation is described here rather detailed. Checks and adjustment of the regulation electronics are done per 6.2.

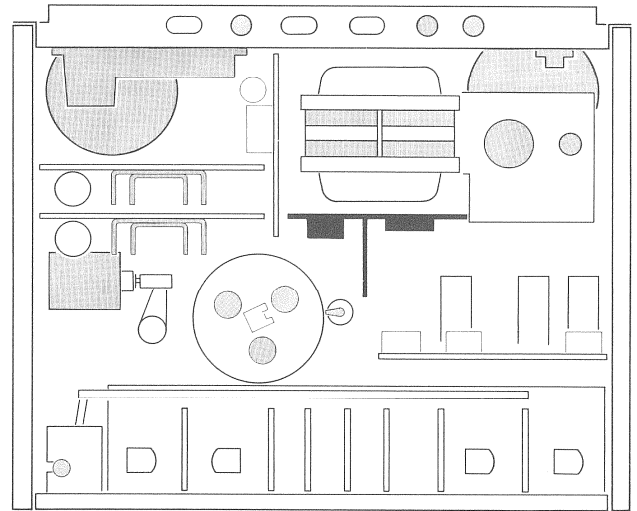

Fig. 5.10–48

The capstan motor speed is electronically measured and continuously regulated. The driving element is a robust and unpretentious asynchronous motor, whose homogeneous outer rotor generates a minimum of torque pulses, reflected in scant wow or flutter.

To measure the speed, a 120-teeth high-precision gear is cut into the outside surface of the rotor. They are inductively counted by a special pick-up head. The speed is then transformed into a proportional frequency which is analyzed for momentary value in an electric circuit. Any deviation from the nominal, 1600 Hz for 7.5 ips and 800 Hz for 3.75 ips, is detected as to magnitude and sign, and changes the voltage applied to the motor.

The actually regulating network (fig. 5.10–49) consists of a bridge rectifier in series with the supply, whose diagonal is loaded more or less by a power transistor. A power transistor with nearly constant base current doesn't show a genuine resistance characteristic (I – V), for it acts as current control element.

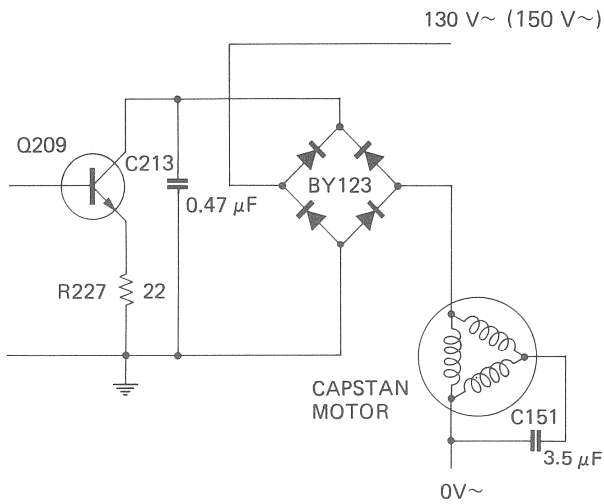

Fig. 5.10-49

Circuit 1.077.725 consists of tachometer signal amplifier (Q 201 to Q 205), the discriminator, and d.c. amplifier with power stage (Q 206 to Q 209). The tachometer signal amplifier amplifies, makes symmetrical and limits the pick-up frequency to supply square wave pulses to the discriminator. D.c. dependent feedback stabilizes the quiescent points of the amplifier stages. The discriminator consists of an LC-series-resonance circuit of utmost constancy due to type of circuit and components used. Best drift characteristics are essential to guarantee the required maximum speed variation of .2 % !

The discriminator frequency can be changed from 1600 Hz to 800 Hz by switching in capacitor C 207. In addition, diode D 201 is polarized in conductive direction, thus requiring at the control side but one low current contact, it also decouples the control line ideally.

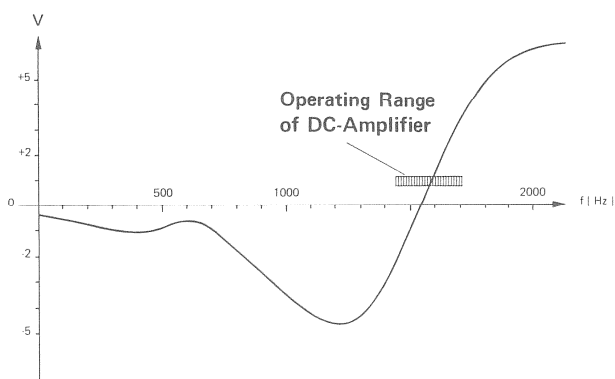

Fig. 5.10-50

The series potentiometer P 201 allows detuning the resonant frequency slightly. This permits calibration of the speed separately. The high speed is set by adjusting primarily the circuit's inductivity. Fig. 5.10 -50 shows the voltage characteristic as a function of frequency for the whole discriminator. The operating range of the following d.c. amplifier is given for clarification.

The discriminator is temperature compensated along with the entire circuitry. Fig. 5.10 -51 shows the typical thermal characteristic of the whole system, measured inside the climatic chamber while motor was running.

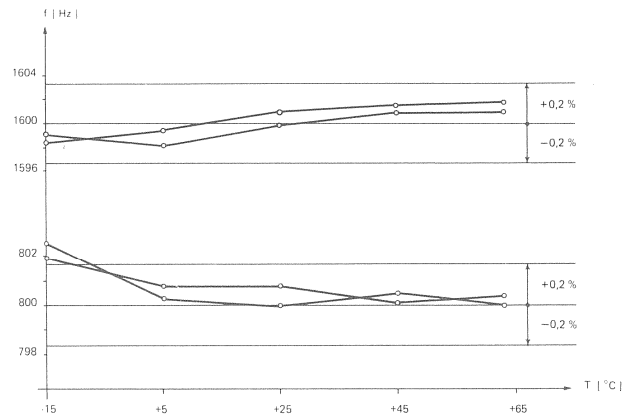

Fig. 5.10-51

The signal, delivered from the discriminator, is stripped of a.c. components from the tachometer frequency by integration (C 210 & C 211). The R 215 - C 209 member corrects phase error in the control circuit and improves stability. D.c. amplifier Q 206 - Q 207, whose operating range is shown in the discriminator characteristic, has an amplification of 40 dB. It brings the signal to the value needed for power amplifier Q 209. The phase inversion stage Q 208 has little amplification. Power stage Q 209 consists of a transistor which resists those peak voltages that can occur during cut-off and is able to conduct the power loss, generated during operation, onto the heat sink.

Some interesting system data :

1. Steepness of the discriminator and amplification factor of the following amplifier cause the motor voltage to traverse from 0 Vac to the maximum value 130 Vac within 3 Hz frequency deviation at the 1600 Hz tachometer signal frequency. This means that the motor receives full or no voltage for a percentage deviation of $\pm 1\%$.
2. Line voltage variations of 20 % cause a deviation in speed of the order of $\pm .04\%$.
3. Variations $\pm 10\%$ in operating voltage 21 V, cause a deviation of speed by $\pm 1\%$ (operating voltage is additionally regulated).

4. Changing the supply frequency from 50 to 60 Hz varies motor speed by less than .05 %.

Point 4 shows that the supply can be alternated between 50 and 60 Hz with absolutely no changes in circuitry. The new motor is considerably lighter than synchronous motors were to date. It has neither flywheel mass nor a soft clutch. The capstan axis is rigidly fixed to the rotor, making interchanges very easy. The relatively low speeds of the capstan motor (400 and 800 rpm) provide a large diameter capstan axis.

Notes

6. ELECTRICAL ADJUSTMENTS AND MEASUREMENTS

Measurement Instruments and Aids

- Demagnetizing coil
- AF-millivolt meter or VTVM (vacuum tube voltmeter)
- AF - generator
- Distortionfactor meter
- Oscilloscope or digital counter
- Wow and flutter meter

- Test Tapes (Reference Tape)

Test tapes per NAB (1965), and DIN Heimton 7.5 ips (1966) and 3.75 ips (1967) are equalized alike for respective speeds.

7.5 ips = 3180 μ sec, 50 μ sec test tape DIN 45513 / 19 H (from AGFA or BASF) or NAB 7.5 ips.

3.75 ips = 3180 μ sec, 90 μ sec test tape DIN 45513 / 9 (from AGFA or BASF) or NAB 3.75 ips (90 μ sec).

- Adjustment Tape 4 - track (.25")

for height adjustment of the magnetic head on 4-track instruments.

All AF and RF measurements are to be taken with shielded cables.

6.1. Demagnetizing

- Magnetic heads and tape guides are to be demagnetized before any measurement or adjustment with running tape.

Strong d.c. - magnetization disimproves signal-to-noise ratio and frequency response. It can also permanently damage the test tapes.

6.2. Tape Speed (Regulator Card 7.077.725)

6.2.1. Pick - up Head - Adjustment

The air-gap between pick-up head and rotor shall be .3 - .4 mm (.012" - .016"). Adjustment is correct when a 35 - 50 mV tachometer signal voltage is measured (at 3.75 ips) on connections blu E2 and brn E1 of the regulator card.

6.2.2. Tacho Adjustment

Exact adjustment of the discriminator, respectively of the capstan motor speed, can be accomplished only with a digital counter.

- Connect digital counter to blu E2, brn E1.
- Switch recorder to PLAY (with tape in place).
- For 7.5 ips, the frequency must be 1600 to 1601 Hz. Measurement time 10 sec. minimum. Apply corrections to core of discriminator coil T 201.
- For 3.75 ips, the frequency must be 800 to 801 Hz (7.5 ips adjustment has to be made first !) - Apply corrections to trimpot P 201.

6.2.3. Tacho Adjustment with Cathode-Ray Oscilloscope

If need be, adjustments can be made with an oscilloscope referenced to the 50 Hz network frequency test point D (diagram 1.077.725) there is (closed to 0V) an a.c. signal of 100 Hz of the following shape :

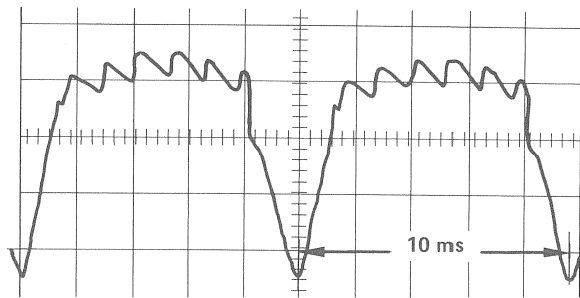

The superposed frequency comes from the regulating system and is 1600 Hz for 7.5 ips, 800 Hz respectively for 3.75 ips.

Measurement is accomplished in the PLAY mode with tape in place. The superposed frequency must remain standing with respect to the base frequency (at 50 Hz network frequency). (Adjustment procedure per 6.2.2.)

6.3. Playback Adjustment

Preparation :

Check regulated supply voltage (21 V). Apply corrections to P 106 (Power Supply Card 1.077.540).

Check of Balance Adjustment :

- Connect AF-generator to AUX-input.
- Parallel the signal voltage on both inputs by bridging the solder terminals of the AUX cinch-connectors with alligator clamp.

- Set controls per fig. 6.3-52

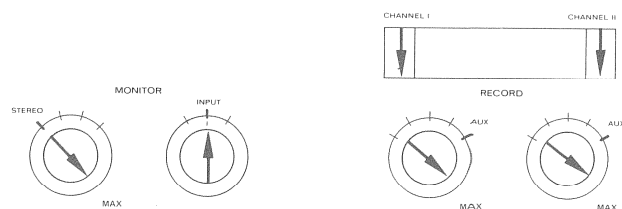

Fig. 6.3-52

- Supply about 30 mV / 1000 Hz.
- Measure signal voltages at the OUTPUT (2 V approx). Both outputs shall have same signal voltages. Apply correction with the balance control for voltage differences at less than 3 dB at the outputs. Check the amplifier channels if the voltage differences are larger.
- Don't readjust the balance control. .

6.3.1. Azimuth Adjustment, Playback Head, Coarse (Max. Level)

(Assembly and coarse adjustment after head exchange per 4.1.2.)

Check of gap centering with respect to polished face :

- Mark polished face with grease pencil. Let tape run short time. The gap must be in center of worn area.
- Set controls per fig. 6.3 –53.

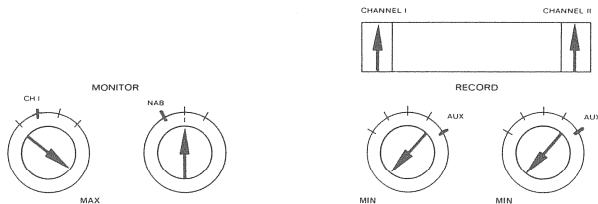

Fig. 6.3–53

- Load 7.5" test tape and advance to azimuth adjustment portion (10 kHz).
- Connect AF-millivoltmeter to an OUTPUT terminal.
- Switch to PLAY and set output voltage to a maximum with screw C (fig. 6.3 –54).

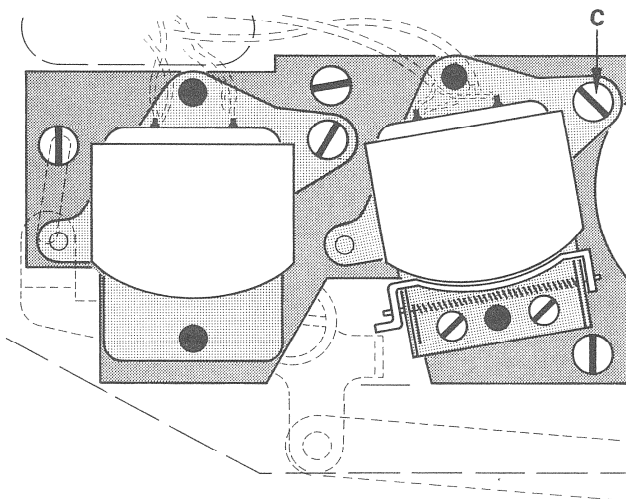

Fig. 6.3–54

6.3.2. Azimuth Adjustment, Playback Head, Fine (Phase Method)

- Set controls per fig. 6.3–55.

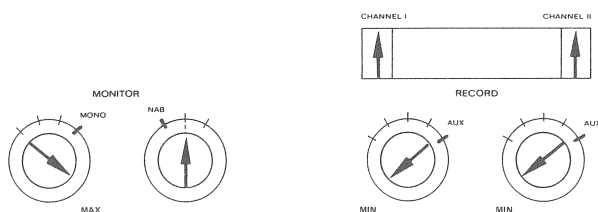

Fig. 6.3–55

- It is absolutely essential to accomplish the coarse adjustment per 6.3.1. before using this method to avoid phase errors larger than 90°.

- Switch to PLAY and set output voltage to a maximum (sharp) with screw C.
- Secure screw C with a drop of lacquer.

6.3.3. Playback Level from Test Tape

- Set controls per fig. 6.3 –56.

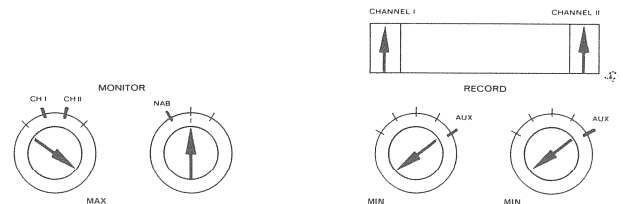

Fig. 6.3–56

- AF-millivoltmeter remains connected to one output (3 V range).
- Advance test tape to level portion.
- Set playback mode switch to CH 1.
- Set output voltage 2 V with trimpot REPR LEVEL CH1 (fig. 6.3 –57).

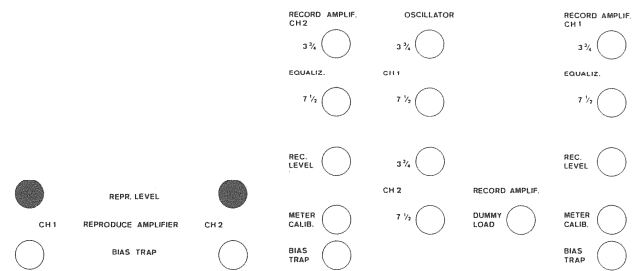

Fig. 6.3–57

- Set playback mode switch to CH 2.
- Set output voltage 2 V with trimpot REPR LEVEL CH 2.

6.3.4. Frequency Characteristic, Playback (from Test Tape)

- Set controls per fig. 6.3.–58.

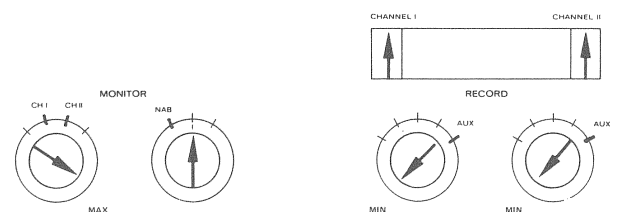

Fig. 6.3–58

- Advance to frequency run portion of DIN or NAB test band.
- AF-millivoltmeter, range 300 mV (-20 dB). Both channels can be measured simultaneously by changing back or forth between each frequency section (CH 1 / CH 2).

6.4. Oscillator and RF - Adjustments

6.4.1. RF - Voltages and Frequency Checking

— Set controls per fig. 6.4 –59

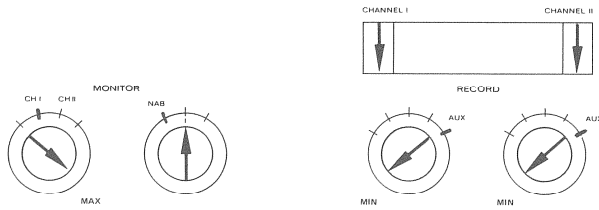

Fig. 6.4–59

— Load tape and switch to RECORD (STEREO).

A. — Measure erase head voltage against ground with VTVM at VU-meter board (fig. 6.4 –60) orange HB3 (CH 2) and blue HB6 (CH 1).

- 2 - Track = 21 Vac each
- 4 - Track = 16 Vac each

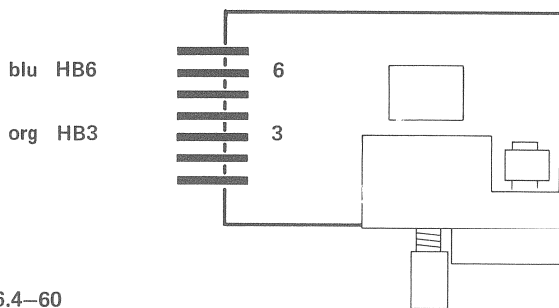

Fig. 6.4–60

B. Oscillator Frequency

- Load tape, switch to RECORD (STEREO). Pull out lamp at optical end-of-tape switch if measuring without tape.
- Oscillator frequency is measured with digital counter or oscilloscope. The frequency is 120 kHz (± 5 kHz) and is measured at orange HB3 and blue HB6 (fig. 6.4 –60) against ground. (Oscilloscope: 12 oscillations per 100 μsec).

6.4.2. Dummy Load

The dummy load compensation is needed only when the erase head is replaced (balance of inductive strays from the erase head during MONO - operation).

- Load tape, switch to RECORD.
- Connect digital counter or oscilloscope to blue HB6 (fig. 6.4 –60).



- Measure RF-frequency in stereo mode.
- Disengage record pre-selector CH 2 and balance DUMMY LOAD till same frequency is reached as in stereo mode.

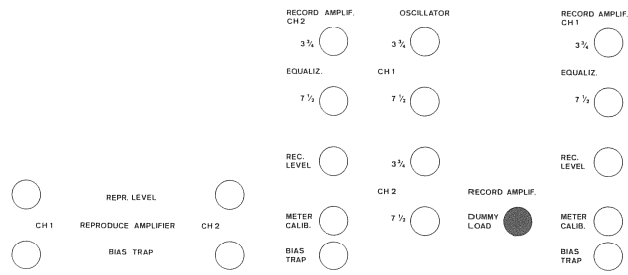
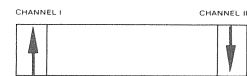

Fig. 6.4–61

- Depress record pre-selector CH 2 and disengage CH 1.
- Connect oscilloscope or digital counter to orange HB3.
- Correct DUMMY LOAD if necessary.



- Repeat adjustment procedure until any remaining frequency deviations are symmetrical around the nominal frequency (e.g. CH 1 + 1 kHz, CH 2 - 1 kHz).

6.4.3. RF - Traps, Record

— Set controls per fig. 6.4 –62

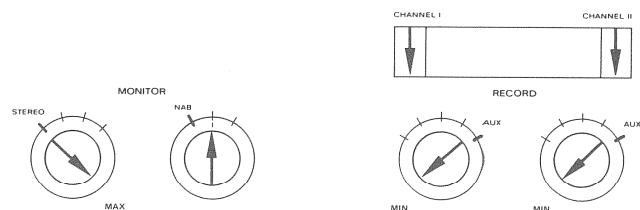

Fig. 6.4–62

- Load tape, switch to RECORD (STEREO).
- Connect VTVM to test point C 515 of the respective record amplifier (fig. 6.4 –63), see also diagram 1.077.705.

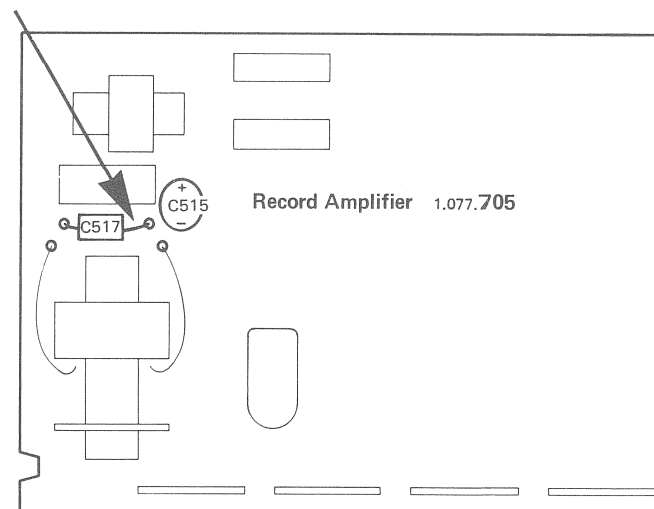

Fig. 6.4.–63

- Set minimum voltage at BIAS TRAP CH 1 and CH 2: Less than < 300 mV (fig. 6.4–64).

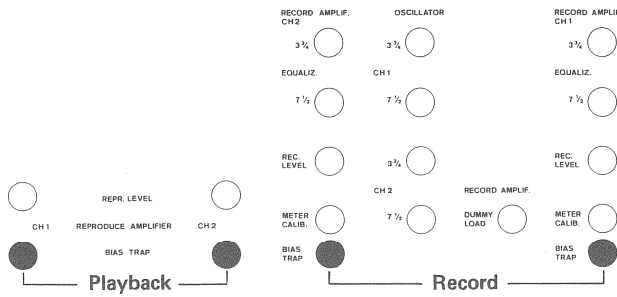

Fig. 6.4–64

6.4.4. RF - Traps, Playback

- Under same conditions as 6.4.3. but, connect VTVM to OUTPUT terminals CH 1 and CH 2 and set BIAS TRAP of playback amplifier to a voltage minimum : Less than < 50 mV (fig. 6.4–64).

6.5. Record - Adjustments

Preparations :

Following measurements (6.5.1. to 6.5.6.) are to be taken with a record level of -20 dB below full modulation level. (To avoid over-modulating high frequencies).

- Set controls per fig. 6.5–65.

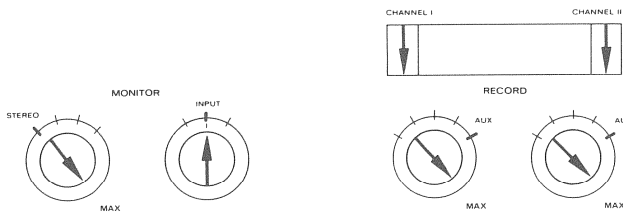

Fig. 6.5–65

- Connect AF-millivoltmeter to OUTPUT terminal.
- 300 mV range
- Adjust AF-generator ($3 - 4$ mV) at 1000 Hz to obtain 200 mV at the OUTPUT terminal (voltage as for playback from test tape per 6.3.3, but 20 dB lower).

6.5.1. Azimuth Adjustment, Record Head, Coarse

- Set controls per fig. 6.5–66.

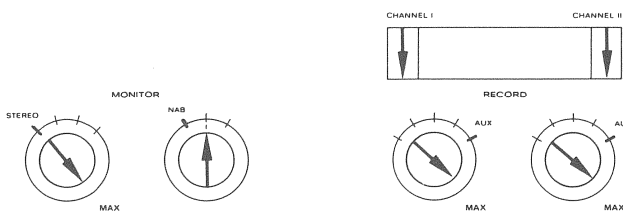

Fig. 6.5–66

- Set AF-generator to 10 kHz (see 6.5. preparations).
- Load tape and switch to RECORD.
- Adjust for maximum signal with screw B (fig. 6.5–67), (turn slowly – indication delay !).

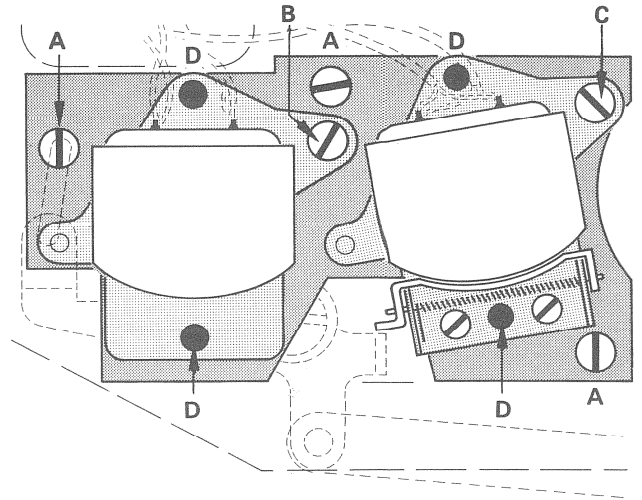

Fig. 6.5–67

6.5.2. RF - Bias

Since the high frequency playback voltage is bias dependent in a curve with distinct maximum, a relationship which can be used to determine the operating point (fig. 6.5–69). The measurement is per 6.5.1. (10 kHz, -20 dB).

Controls OSCILLATOR CH 1 and CH 2, 3.75 and 7.5 (fig 6.5–68) are turned from the left limit in clockwise fashion until maximum AF output voltage is reached (playback mode switch by choice CH 1 / CH 2).

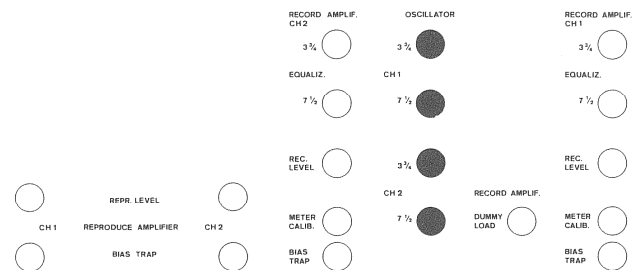

Fig. 6.5–68

Note the pointer deflection at the maximum and continue turning in the same sense till AF-output voltage has dropped by the amount (ΔV) shown in the following table.

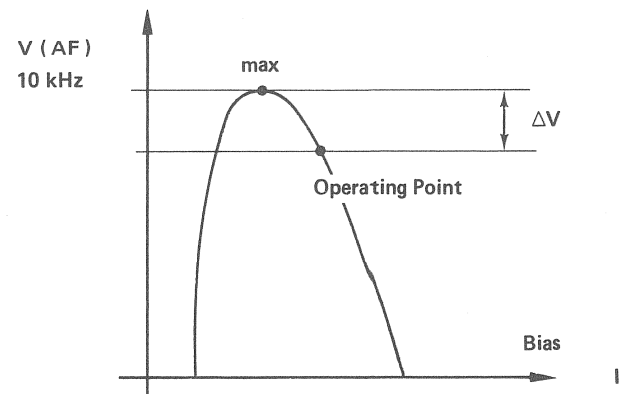

Fig. 6.5–69

Type of Tape	ΔV - 3.75 ips	ΔV - 7.5 ips	ΔV -15 ips
AGFA PE 31	4 dB	3 dB	
REVOX PE 36 RX REVOX 207 REVOX 601 AGFA PE 36 BASF PES 35 (LH) SCOTCH 202/203	5 dB	4 dB	2 dB
SCOTCH 150/215	5 dB	5 dB	
REVOX 621	4,5dB	4dB	2dB

Table 6.5-69

6.5.3. Azimuth Adjustment, Record Head, Fine

Set controls per fig. 6.5-70

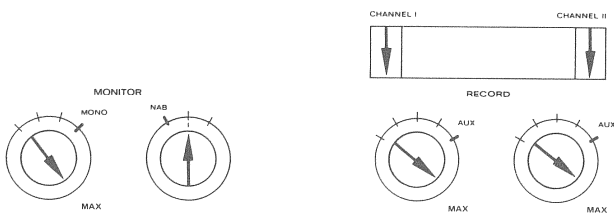

Fig. 6.5-70

- The balance regulator must be set accurately (per 6.3, preparations).
- Other conditions as up to now (Record, Stereo, 10 kHz, - 20 dB).
- Set output voltage to a maximum (sharp) with screw B (fig. 6.5-67) turn slowly - indication delay !).
- It is absolutely essential to accomplish the coarse adjustment per 6.5.1. before using this method to avoid phase errors larger than 90°.
- Control possibility :
Pass through lower frequencies with sound generator. Output voltage shall remain constant.
- Secure setscrew with a drop of lacquer.

6.5.4. Record level

- Set controls per fig. 6.5-71.

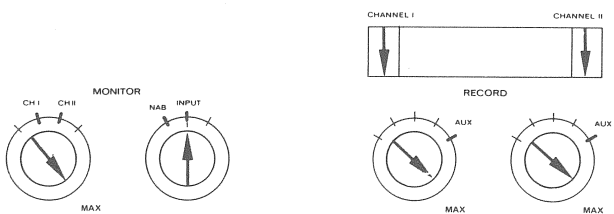

Fig. 6.5-71

- Playback level (per 6.3.3.) and balance adjustment (per 6.3. preparations) must be set.
- AF-generator to AUX-input (connect in parallel).
- AF-millivoltmeter to one OUTPUT terminal, range 300 mV.

- Load tape, switch to RECORD (Stereo).
- Before-and-after-tape switch to INP. Supply 1000 Hz from AF-generator, set generator level such that OUTPUT terminal voltage is 200 mV.
- Switch to NAB and adjust REC LEVEL trimpots (fig. 6.5-72) to obtain 200 mV at OUTPUT terminal, playback mode switch to CH 1 or CH 2 respectively.

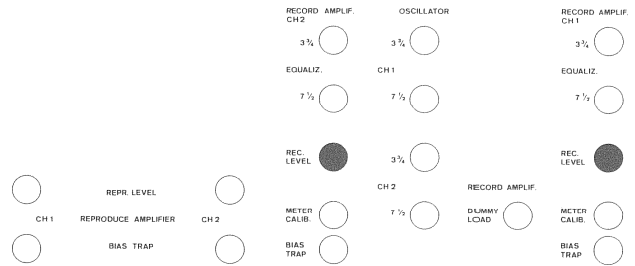

Fig. 6.5-72

6.5.5. Record Equalization

- Switch AF-generator at same voltage (-20 dB) to 12 kHz.
- Set controls per fig. 6.5-71 (NAB).

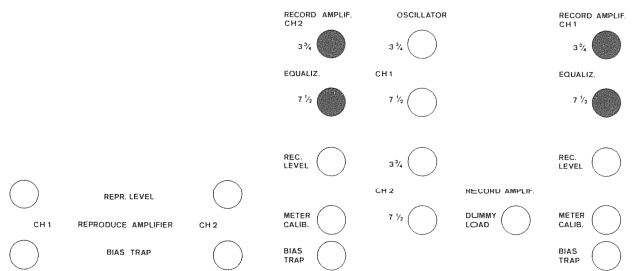

Fig. 6.5-73

- Adjust output voltage from 0 to + 1 dB with trimpots EQUALIZ. (0 dB = 200 mV / 1000 Hz per 6.5.4). Playback mode switch CH 1 both speeds, likewise CH 2 both speeds.

6.5.6. Frequency Characteristic via Tape

- Set controls per fig. 6.5-71 (NAB).
- Calibrate AF-millivoltmeter (change slightly the signal voltage till 0 dB or even-numbered indication is reached).
- Measure frequency characteristics 7.5 ips and 3.75 ips (by changing playback function switch CH 1 / CH 2, both channels can be measured, one after the other).

6.6. Distortion Factor Measurements

- VU-Meter Calibration
- Noise Measurement
- Erase Attenuation
- Crosstalk Attenuation

6.6.1. Distortion Factor (via Tape), VU-Meter Calibration

- Set controls per fig. 6.6-74.

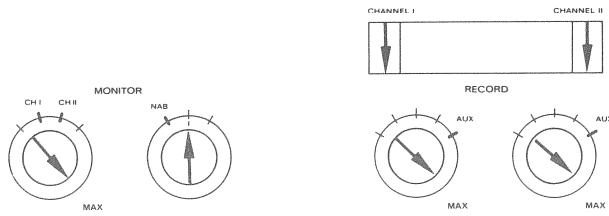

Fig. 6.6-74

- AF-generator (500 Hz). Switch 20 dB higher with respect to previous setting (input voltage about 40 mV)
- Connect distortion factor meter to an OUTPUT terminal.
- Load tape, switch to RECORD (Stereo) 7.5 ips.
- Measure distortion factor (CH 1 and CH 2).
- Set input level so that the distortion factor is 2 % on the worse channel at 7.5 ips.
- Repeat procedure with 3.75 ips. Distortion factor may be 3 %. In case of higher values, reduce input level till 3 % distortion factor is achieved.
- Distortion factor control " Before-tape " : Set before-and after-tape switch to INP. Distortion factor shall be 1 % maximum !
- Switch back to NAB lower input level by 6 dB.
- Adjust METER CALIB (fig. 6.6 -75) with trimpots CH 1 and CH 2, VU-meter indication 0 dB (100 %).

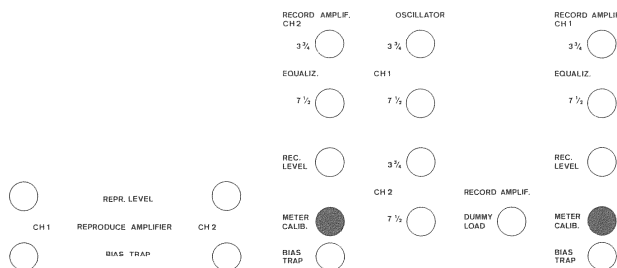

Fig 6.6-75

6.6.2. Noise Voltage (and External Voltage) via Tape

- Noise voltage measurements refer to full-modulation (distortion factor 2 % at 7.5 ips, 3 % at 3.75 ips resp. per 6.6.1.)
- To avoid RF-interference errors, a tape erased on the recorder is measured in the PLAYBACK mode.

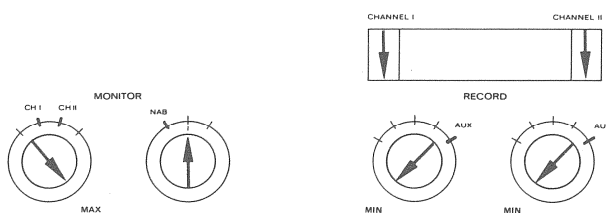

Fig. 6.6-76

Effective values (weighted, CCIF filter) of the noise and external voltages can be seen for the REVOX 601 tape in the following table:

	2 Track		4 Track	
	7.5 ips	3.75 ips	7.5 ips	3.75 ips
Noise Voltage	> 66 dB	> 63 dB	> 62 dB	> 59 dB
Ext. Voltage	> 58 dB	> 57 dB	> 56 dB	> 54 dB

Table 6.6-77

If these noise and external voltage separations are not attained, the tape guide elements and magnetic heads are, once more, to be demagnetized carefully.

6.6.3. Noise Voltage, External Voltage " Before-Tape " (Check)

- Switch recorder to STOP.
- Before-and-after-tape switch to INP (fig. 6.6 -78).

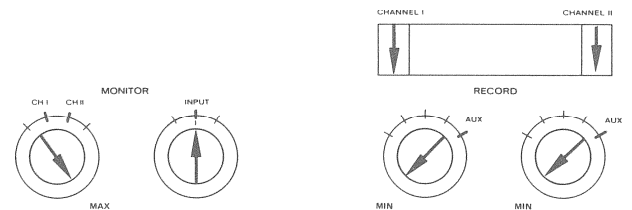

Fig. 6.6-78

The noise and external voltage separation shall be more than 75 dB, referred to full-modulation.

Check of Input Amplifier :

- Set controls per fig. 6.6 -79
- To avoid hum interference during this procedure, the microphone inputs (jacks or cinch connectors) are to be terminated with 200 ohm.

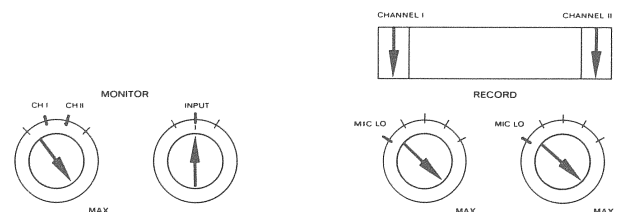

Fig. 6.6-79

The noise and external voltage separations shall be more than 45 dB referred to full-modulation.

6.6.4. Erase Attenuation

Following Measurements: Erase attenuation, crosstalk, mono and stereo (6.6.4 – 6.6.6.) can be taken with a selective VTVM (band width less than 100 Hz).

To measure erase attenuation, a frequency of about 1000 Hz is recorded and consecutively erased. The record remaining on the tape is then measured.

- Set controls per fig. 6.6 –80
- Record 1000 Hz, full-modulation.

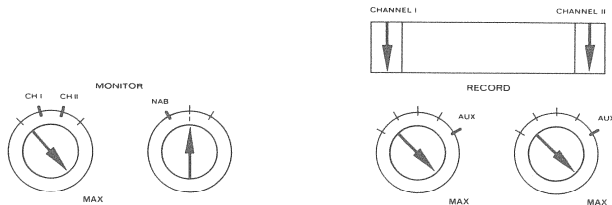

Fig. 6.6–80

- STOP, rewind tape.
- Close record volume controls (fig. 6.6–81).

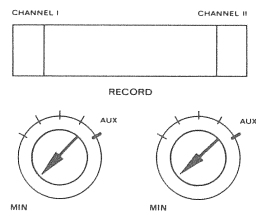

Fig. 6.6–81

- Switch recorder to Record and measure the erase attenuation.

The remainders on the tape shall be better than 75 dB under the level of full-modulation.

6.6.5. Crosstalk, Mono (selective per 6.6.4.)

A mono-recording 1000 Hz full modulation is appropriately taken 1 min on CH 1 and afterwards 1 min on CH 2 for this measurement on a factory-tape. Note that the record butt on the unused channel is disengaged.

- Set controls per fig. 6.6 –82.

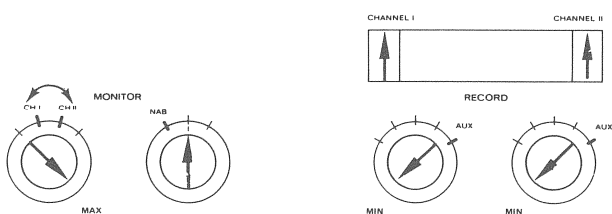

Fig. 6.6–82

Set playback function switch to CH 2, measure the crosstalk separation 1 - 2 and bring with crosstalk compensation trimmer (fig. 6.6 –83) to best value (more than 60 dB).

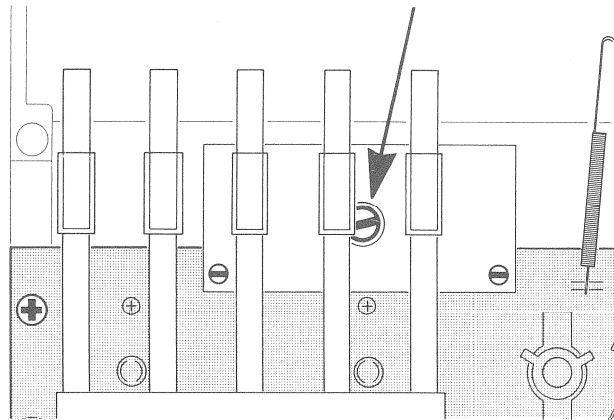

Fig. 6.6–83

- Advance tape to recording on channel 2.
 - Set playback function switch to CH 1, measure crosstalk separation 2 - 1, correct P 305 if necessary.
- For strong corrections, repeat crosstalk 1 - 2 measurement and adjust for mean value.

6.6.6. Crosstalk, Stereo (selective 6.6.4.)

Measure and if necessary adjust mono crosstalk attenuation per 6.6.5. before checking the stereo crosstalk attenuation.

Don't disturb P 305 compensation trimmer during the following measurements.

- The generator is switched in parallel on the AUX-inputs while measuring stereo crosstalk attenuation. Close the input to the channel to be measured.
- Set controls per fig. 6.6 –84.

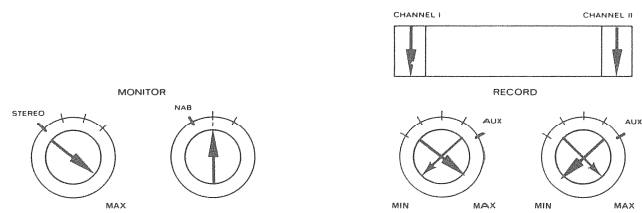

Fig. 6.6–84

→ I - II → II - I

- AF-generator 1000 Hz, full modulation, record stereo.

Measurement 1 – 2 :

- AF frequency millivoltmeter at output CH 2, record volume control CH 1 fully open (at right limit), record volume control CH 2 fully closed (left limit).

Measurement 2 – 1 :

- AF frequency millivoltmeter at output CH 1, record volume control CH 2 fully open (at right limit), record volume control CH 1 fully closed (left limit).
- Crosstalk attenuation shall be better than 45 dB.

6.7. Output Voltage Check

– Set controls per fig. 6.7 –85

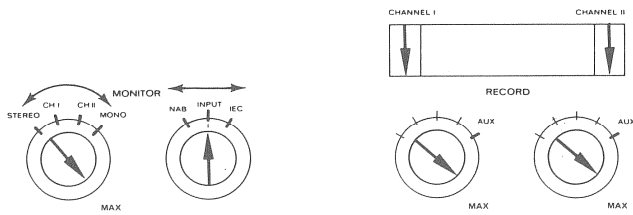

Fig. 6.7–85

- Load tape, switch to Record (Stereo).
 - AF-generator 500 Hz, full modulation.
 - AF frequency millivoltmeter at output CH 1 or CH 2.
- Output voltage shall remain constant (± 1 dB), when the before-and-after-tape switch INP / NAB / IEC and the play-back mode switch STEREO / CH 1 / CH 2 / MONO is switched around. If the output voltage doesn't stay within the indicated tolerance, proceed per 6.5.4.

6.8. Wow and Flutter

The values given in the technical data are measured with a wow and flutter meter per Std DIN 45507. Values obtained by a different standard can't be compared.

7. ACCESSORIES

7.1. Remote Control

All push button functions can be accomplished by REMOTE CONTROL. The remote control cable needs no shielding and its length is not critical.

The remote control unit circuitry is per fig. 7.1–86.

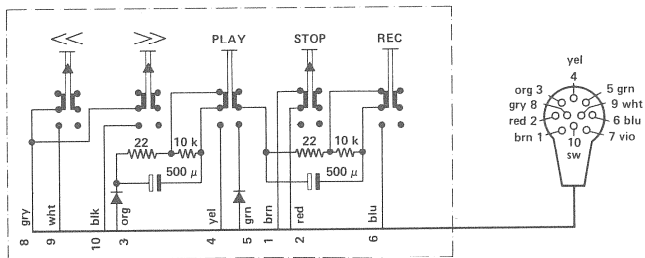

REMOTE CONTROL PLUG (HIRSCHMANN WIST 10)

Fig. 7.1–86

The 27 Vdc on terminal 7 is for use with slide projectors (load 150 mA maximum).

The dummy connector must be inserted for operation without the REMOTE CONTROL unit (this dummy connector shorts terminals 1 & 2).

7.2. Operation with a Timing Clock

The timing device is to be wired into the electric power feed in a manner which will provide electric current to the REVOX A77 during predetermined intervals only. For operation with a timing clock, the power switch and speed selector remains continuously in the position of the desired tape speed.

8. MODIFICATIONS

8.1. Rewind

For bad rewind with 18 cm (7") reels :
Replace resistor R 125 (820 Ohm) by resistor 1.2 kOhm,
9 Watt (drive control 1.077.370).

8.2. Switch Noise

The following change can improve the situation where operation of the STOP button out of RECORD and PLAY modes causes clicks :

Ground connection brn (fig. 3.13 –18) is unsoldered from the printed side and resoldered to the ground conductor at playback switch S5 (switch board 1.077.435).

Another improvement results from replacing the diode D 601 (record relay card) by an RC-network: $C = 50 \mu\text{F} / 30 \text{ V}$, $R = 100 \text{ Ohm} / 1/8 \text{ W}$ (series connected, observe polarity).

8.3. RFI

Interference from strong radio an TV transmitters can be removed by the following measures :

Solder 1500 - 5000 pF ceramic capacitors from ground connection shield (shielded cable) to chassis (tubular rivet of connector fastening) at the disturbed inputs (see example C 154 OUTPUT terminal).

Powerful UHF television transmitters may be picked up by the playback head cables. If an interfering buzz occurs, the following change should be effected in the playback amplifier:

Connect a capacitor of 100 pF (maximum 220 pF) from base to emitter of Q 803 (similar to C 803 on Q 801).

8.4. Transfer Play Sensitivity

Resistor R 316 and R 321 are 10 kOhm in recorders of lot 1. Substitution with 3.3 kOhm resistors ups recording sensitivity (gain 10 dB approx).

8.5. Replacement of Capstan Motor

Starting with Serial Nos. S15500 and G16150 a new type of Capstan-Motor was installed which operates on a 20 V higher supply voltage and therefore requires a modified power-transformer. The voltage appearing at point E8 blu (speed control board 2.077.725) now measures 150 V. When using an old motor in conjunction with a new transformer, a type 40318 transistor must be used in position Q 209 on the speed control board.

8.6.

Capstan Motor with Sleeve Bearings

Modification effective from serial Nr. S 60483 and G 78003

for illustration see parkslist page E 10.

The capstan shaft extends through the full length of the motor and is supported by two sintered-bronze bearings. The lower bearing is designed to restrict the axial movement of the shaft by means of a plastic coated thrust (low-friction) washer. All bearings are lubricated for their life and will normally not require any service.

Capstan shaft and low-friction washer may be replaced in the field.

If a bronze bearing has become defective, the motor must be sent to the nearest factory service-center. (For disassembly instructions see section 3.7.)

8.6.1.

Removal of Capstan Shaft and low-friction Thrust Washer

Removal of capstan shaft and low-friction washer is possible while the motor remains installed in the recorder.

- Carefully remove shaft lock A by pulling it sideways with a pair of angled pliers. DANGER! Do not attend to pry the lock loose with a screw-driver etc. because it will fly off quite forcefully. Slide off the rotor portion of the capstan motor.
- After removal of the tape guide between the playback head and the capstan shaft, the shaft can be pulled up and out of the motor. (Take care not to disturb the setting of the adjusting nut on the tape guide.)
- To remove the low-friction washer take out the circlip B with the aid of special pliers. The bearing parts can now be disassembled in the following order: Springwasher E, low-friction washer F and thrust bearing G.
- The capstan shaft may now be removed by pulling it downwards and out of the motor.
- When re-assembling the lower bearing, apply one drop of Isoflex PDP65 oil to the low-friction washer.

When handling shaft and bearing, extreme care must be exercised, so as to avoid damaging them and to prevent any dust particles from entering the precision bearings. (runout accuracy 1/1000 mm).

9. TROUBLE SHOOTING

Pre - Check :

Check network voltage.

Allowable deviation (also for short periods) at respective settings of the voltage selector :

110 Vac :	min	96 Vac,	max	125 Vac
130 Vac :	min	112 Vac,	max	145 Vac
150 Vac :	min	130 Vac,	max	165 Vac
220 Vac :	min	190 Vac,	max	245 Vac
240 Vac :	min	210 Vac,	max	270 Vac
250 Vac :	min	225 Vac,	max	290 Vac

Use a regulator if the deviations are higher. Note that regulators have a marked leakage field (keep far from recorder).

Check of regulated supply voltage 21 Vdc. Adjust on P 106 or replace diode D 104, if necessary.

9.1. Faults in the Drive

Capstan Motor fails to run :

Check motor capacitor C 151.

Check regulation electronics, test points (diagram 1.077. 725).

If the capstan motor does not start by itself after manual stopping, the regulator pre-amplifier is oscillating. Exchange R 206 (100 Ohm) against 330 Ohm.

Check capstan bearings, exchange ball bearings against factory - new original ones.

Capstan motor rumbles :

Exchange bearings against factory - new original ones.

Capstan motor whistles :

Check gap rotor to pick-up (per 6.2.1). Put a strip of rubber or equivalent between pick-up and its mounting surface for vibration isolation.

Unpotted pick-ups are to be exchanged for potted ones.

Tape Speed too low :

Check pick-up separation. Measure pick-up frequency (per 6.2.2). Check regulation electronics, test points.

Wow and Flutter :

Mechanical causes :

Periodic wow and flutter whose origin is in a defective pressure roller or whipping capstan axis can be recognized by observing the rotating element's rhythm (pressure roller or capstan axis might be marked with felt tip pen). Pressure roller, see also 4.4.1.

If rhythm of wow is identical with the rotation of the left-hand reel motor, the origin may be either mechanical or electrical. The mechanical cause may be defective bearing or misadjusted brake.

Electrical causes :

Overly strong counter torque of left-hand reel motor can be cause for wow; check motor voltages, see table 5.9 —46.

If wow occurs only at 3.75 ips, it may have its origin in too large a distance of pick-up or in the regulation circuit, (see 6.2.1).

Wow at both speeds may be caused by a defective capacitor in the RC-network R 215/ .C 209 in the regulation circuit. Replace capacitor.

Inadequate Starting Behavior, Slow Rewind :

Reels smaller than 60 mm (2 - 3/8'') should not be used if at all possible.

Optimum behavior can be expected only at nominal line voltage.

Check reel motors with loosened brakes for light run (axial play of reel motors .2 to .3 mm (.008 to .012'').

Increase R 125 to 1 or 1.2 kOhm.

Push Buttons Don't Hold :

Dummy connector REMOTE CONTROL is missing.

End-of-tape switch is defective, see 5.9.1, or strong light is incident on photoresistor.

Check relay operating voltage (27 Vdc).

End-of-Tape Switch Doesn't Function :

Lamp defective. Check photoresistor and trigger, see 5.9.1.

Pressure Solenoid Doesn't Function :

Check drive control, relay contacts, and diode.

Brake Solenoid Doesn't Function :

Check solenoid coil.

Clean core.

Check relay operating voltage (27 Vdc).

Brakes (STOP) too weak, too strong, irregular :

Check brake bands, check brake lining.

Clean and degrease.

Measure brake tension per 4.3.

9.2. Faults in Circuitry

Pre-Check :

See Pre-Check 9.

Playback Amplifier Hums :

Break in playback head windings.

Flap shield doesn't close adequately.

Supply voltage 21 Vdc, hum voltage too high.

Capstan motor leakage field too high, check supply voltage, 100 V_{eff} max.

Possibly strong interference from UHF-TV transmitters, see. 8.3.

Line voltage too low, see 9 (pre-check).

Playback Amplifier Noisy (Drive Amplifier)

with closed volume control :

Defective transistor Q 803 or Q 804.

Amplification too high from defective balance potentiometer.

Noisy zener-diode in power supply, replace with planar type.

Inadequate matching to following amplifier. Open VOLUME control completely, adjust volume in amplifier.

Playback Amplifier Noisy :

with open volume control :

Condition: Function PLAY; without tape in place (optical end-of-tape switch: Cover light); before-and-after-tape switch position NAB / IEC.

Defective transistor Q 801 or Q 802.

Check tantalum capacitors.

Recording Noisy :

with closed record volume control :

Check playback amplifier.

Clean and demagnetize magnetic heads.

Procedure with pulled record amplifier, once fault is corrected, record amplifier found defective :

Replace transistor Q 501 or Q 502.

Check C 515 for leakage current, check tantalum capacitors.

If fault persists with pulled record amplifier :

Defective oscillator or erase head - replace.

with open record volume control :

If noise occurs only with open record volume control, check input amplifier.

Check Q 401 / 421 and Q 402 / 422.

Check tantalum capacitors.

Highs Playback Weak or Variable :

Dirty magnetic heads.

Tape is not of type pre-scribed by manufacturer.

Wrong bias (record equalization), see 6.5.2. to 6.6.

Playback head misadjusted, see 6.3.1.

Record head misadjusted, see 6.5.1.

Worn magnetic heads.

No Record :

Check relays.

Check relay Q 601.

Replace oscillator.

Inadequate Erase :

Dirty erase head.

Measure RF-voltage; if it is too low, check supply voltage at oscillator.

Defective erase head.

Tape extremely over-modulated.

VU-Meter, None or Faulty Indication :

Defective VU-meter.

Calibration misadjusted, P 504.

Defective rectifier D 351 - D 354 (VU-meter board 1.077.480).

Defective amplifier, Q 503 (record amplifier card 1.077.705)

Switching Clicks :

see Modifications 8.2.

RFI (Radio Frequency Interference) :

see Modifications 8.3.

Transfer Play Sensitivity Too Low :

see Modifications 8.4.

NACHTRAG ZU DER EINSTELLANLEITUNG (Kapitel 6)

Im Laufe der Zeit erfuhr die A77 diverse Anpassungen, durch welche einige Einstellarbeiten nun von den in der vorhergegangenen Anleitung beschriebenen abweichen. Die Abweichungen sind nachfolgend mit der entsprechenden Seiten- und Kapitelnummerierung versehen aufgeführt.

Seite 14, Kapitel 4.4.1 Messung der Andruckkraft

Die Andruckkraft bei Geräten mit polierter (glänzender) Tonmotorachse beträgt 1,5 kg, bei Geräten mit sandgestrahlter Tonmotorachse (matt) 1,2 kg.

Seite 23, Kapitel 5.10 Speed Regulation, Capstan Motor

Druckfehler, die Nummer 7.077.725 heisst richtig 1.077.725 (nur im englischen Text).

Seite 25, Kapitel 5.11 Speed Regulation, Capstan Motor 1.077.724 (neues Kapitel)

Das gesamte Regelungssystem besteht aus Tonmotor, Regelelektronik und Tachometer zur Drehzahlmessung.

In der Eingangsschaltung mit IC201 wird die zur Bandgeschwindigkeit proportionale Frequenz in ein Rechtecksignal umgeformt. Die nachfolgende Frequenzteilerschaltung sorgt für ein exakt symmetrisches Signal. Die negativen Flanken des frequenzgeteilten Rechtecks triggern eine monostabile Kippstufe (Präzisionstimer IC202). Durch Unterdrückung jedes zweiten Impulses bei der hohen Geschwindigkeit muss der Motor doppelt so schnell drehen, um dieselbe Triggerfrequenz und damit dasselbe Signal am Ausgang von IC202 zu erhalten. Die Impulsbreite wird für IC202 durch einen hochstabilen RC-Serienskreis bestimmt. Mit Potentiometer R217 kann die Sollgeschwindigkeit eingestellt werden. Ein Tiefpass bildet den DC-Mittelwert aus dem Rechtecksignal. Dieser wird im nachfolgenden DC-Verstärker, welcher ein Netzwerk für die Stabilität des Regelkreises enthält, weiterverarbeitet und steuert schliesslich als Gleichspannungswert den Regeltransistor Q205 an. Bei äusseren Drehzahländerungen variiert das Tastverhältnis des Signals bei Punkt F und somit auch die Steuerungsspannung für den Regeltransistor.

Durch das Anlegen einer externen Referenzspannung am Anschluss CONTROL VOLTAGE bei IC202 kann die eingestellte Frequenz über einen grossen Bereich verändert werden (variable Bandgeschwindigkeit).

Seite 26, Kapitel 6.2.4 Tachoabgleich 1.077.724 (neues Kapitel)

Der Luftspalt zwischen Tachokopf und Rotor soll 0,3 ... 0,4 mm betragen. Die Einstellung ist in Ordnung, wenn an den Anschlüssen E1 (brn) und E2 (blu) 35 ... 50 mV (bei der kleineren Geschwindigkeit) Tachometer-Signalspannung gemessen wird.

SUPPLEMENT TO THE ADJUSTMENT INSTRUCTIONS (Chapter 6)

Over the years, a few adaptations have been introduced for the A77. Adjustment work may therefore differ. The following paragraphs replace or must be added to the indicated page and chapter number.

Page 14, Chapter 4.4.1 Measuring the pinch roller force

Pinch roller pressure must be 1.5 kg at polished shafts (shiny); at sandblasted capstan shafts (mat), pressure must be 1.2 kg.

Page 23, Chapter 5.10 Speed Regulation, Capstan Motor

Printing error, the number 7.077.725 should be 1.077.725 (only in the English text).

Page 25, Chapter 5.11 Speed Regulation, Capstan Motor 1.077.724 (new chapter)

The speed control system consists of the capstan motor, the speed regulating circuit and the tachometer head to sense the motor speed.

The input circuit with IC201 shapes the speed which is proportional to the frequency into a square wave and the following divider circuit delivers an exactly symmetrical signal. The trailing edges of the square wave are triggering a mono flip-flop (precision timer IC202). When selecting the higher tape speed, every second pulse becomes suppressed, thus the motor has to run with double speed in order to produce the same trigger frequency and consequently the same signal at the output of IC202. The pulse width for IC202 is determined in a highly stable RC-series network. With R217, the motor speed can be adjusted to its nominal value. By passing the signal through a low-pass network, an average DC-value is derived from the square wave. This DC-potential is further processed in a DC-amplifier, which contains a network to ensure the stability of the control loop. The DC-signal then reaches the base of the regulating transistor Q205. A variation in motor speed will also vary the duty cycle at F with a consequent change of the bias potential for the regulating transistor. By feeding an external reference potential to the terminal CONTROL VOLTAGE at IC202, the adjusted frequency may be varied over a wide range (variable tape speed).

Page 26, Chapter 6.2.4 Tacho Head Adjustment 1.077.724 (new chapter)

The air gap between the tachometer head and the rotor of the capstan motor should amount to 0.3 ... 0.4 mm/0.011 ... 0.02 inches. The head is correctly positioned when measuring a signal voltage of 35 ... 50 mV at lower speed between the connectors E1 (brown) and E2 (blue).

SUPPLEMENT POUR INSTRUCTIONS DE RÉGLAGE (chapitre 6)

Le magnétophone A77 ayant subi divers changements au cours du temps, il s'est avéré nécessaire de modifier certains réglages décrits dans les instructions précédentes. Ce supplément concerne les pages et les chapitres suivants.

Page 14, chapitre 4.4.1 Mesure de la force d'appui

La force d'appui du galet est de 1,5 kg pour les magnétophones ayant un axe de cabestan lisse (brillant) et de 1,2 kg pour ceux avec un axe sablé (mat).

Page 23, chapitre 5.10 Régulation de vitesse du moteur de cabestan

Suite à une erreur d'impression le numéro 7.077.725 est 1.077.725 (seulement dans la version anglaise).

Page 25, chapitre 5.11 Régulation de vitesse du moteur de cabestan 1.077.724 (nouveau chapitre)

L'ensemble du système se compose du moteur de cabestan, de l'électronique de régulation et de la tête tachymétrique.

L'étage d'entrée (IC201) met en forme le signal provenant de la tête tachymétrique. L'étage suivant formé d'un diviseur de fréquence donne un signal parfaitement symétrique. Les flancs négatifs du signal rectangulaire commandent ensuite une monostable de précision (IC202). La suppression d'une impulsion sur deux oblige le moteur à tourner deux fois plus vite afin de retrouver la même fréquence de commande et le même signal à la sortie de la monostable (IC202). Un réseau RC de précision garantit la stabilité de la largeur des impulsions délivrées par IC202. La vitesse nominale se règle avec le potentiomètre R217. Après le passage dans un intégrateur donnant la valeur moyenne du signal, celui-ci peut attaquer un ampli à courant continu contenant un circuit pour la stabilité de la régulation. Cette tension continue commande finalement le transistor de régulation Q205. Une variation extérieure de la vitesse de rotation changera le rapport d'impulsions au point F et par conséquent la tension appliquée au transistor de régulation. L'application d'une tension de référence au point CONTROL VOLTAGE de l'IC202 permet de varier la vitesse dans une large gamme.

Page 26, chapitre 6.2.4 Réglage de la tête tachymétrique 1.077.724 (nouveau chapitre)

L'espace entre la tête tachymétrique et le rotor du moteur doit être de 0,3 à 0,4 mm. Le réglage est correct lorsque la tension mesurée entre E1 (brun) et E2 (bleu) est de 35 à 50 mV pour la plus petite vitesse.

Geschwindigkeits-Eichung

- Band einlegen und Gerät auf hoher Bandgeschwindigkeit auf Wiedergabe starten.
- Zähler an IC202, Pin 3 (F) und Masse auf Drehzahlregelungs-Steckkarte anschliessen.
- Zähler-Anzeigewert gemäss Tabelle A, bei Abweichungen mit R217 korrigieren.
- Gerät auf kleine Bandgeschwindigkeit umschalten, die Anzeige am Zähler darf nicht ändern.

Bei beiden Geschwindigkeiten muss die Anzeigetoleranz innerhalb 1 Hz liegen.

Tape Speed Calibration

- Connect digital counter at pin 3 (F) of IC202 and ground (E2, blue wire) located on speed control PCB.
- Load recorder with tape, select high tape speed and start recorder in PLAY-mode.
- The counter display should be as per table A, correction can be made with R217.
- Switch recorder to low tape speed, read-out must be the same.

At both tape speeds, the indicated frequency must be between ± 1 Hz of the nominal frequency.

Réglage de la vitesse

- Connecter un compteur entre le point 3 (F) de l'IC202 et le fil bleu E2 (masse) sur la carte de régulation.
- Faire défiler une bande en lecture à grande vitesse.
- Avec R217 régler la fréquence en fonction de la table A.
- Commuter en petite vitesse, la valeur ne doit pas changer.

Pour les deux vitesses la tolérance est de 1 Hz.

cm/s	2,37 / 4,75	4,75 / 9,5	9,5 / 19	19 / 38
ips	15/16 / 1 7/8	1 7/8 / 3 3/4	3 3/4 / 7 1/2	7 1/2 / 15
Hz	300	400	800	800

Seite 27, Kapitel 6.3.3 Wiedergabepegel ab Testband

Bedingt durch die neueren Bandsorten, welche eine erheblich höhere Magnetisierung zulassen (Pegeltonteil bei 1000 Hz bezogen auf 257 nWb/m = 0 VU) ändern in der folgenden Einstellung die Pegel. Die Ausgangsspannung (regelbar mit Trimpotentiometer REPR LEVEL CH1/CH2) wird anstelle 2 V auf 1,55 V eingestellt.

Page 27, Chapter 6.3.3 Reproduce Level from Test Tape

The reproduce levels have been changed due to new tape brands that allow quite a higher magnetization (test tape playback level by 1000 Hz, 257 nWb/m = 0 VU). Adjust the output levels to 1.55 V instead of 2 V (adjustable with trimmpotentiometer REPR LEVEL CH1/CH2).

Page 27, chapitre 6.3.3 Niveau de référence avec bande étalon

Les nouvelles bandes, permettant un niveau de magnétisation plus élevé, nécessitent un changement du point de réglage. Régler la tension de sortie avec les potentiomètres REPR LEVEL CH1/CH2 à 1,55 V au lieu de 2 V (1000 Hz 257 nWb/m = 0 VU)

Seite 28, Kapitel 6.4.1 HF-Spannung und Frequenz kontrollieren

Die HF-Spannungen sind je nach Oszillator und Geschwindigkeit unterschiedlich:

Oszillator/Oscillator/Oscillateur	1.077.710 (MPA + MPB)	2 Spur/track/pistes	ca./approx./env.	22 V / 120 kHz
Oszillator/Oscillator/Oscillateur	1.077.730 (MPA + MPB)	4 Spur/track/pistes	ca./approx./env.	18 V / 120 kHz
Oszillator/Oscillator/Oscillateur	1.077.795 (Mono)	MPA	ca./approx./env.	44 V / 120 kHz
		MPB	ca./approx./env.	800 mV / 120 kHz
		resp.		80 mV / 1 kHz

Page 28, Chapter 6.4.1 RF-Voltages and Frequency Checking

RF-voltages differ depending on used oscillator and tape speed selected:

Page 28, chapitre 6.4.1 Contrôle de la tension HF

La tension HF diffère selon le type d'oscillateur:

Seite 29, Kapitel 6.4.4 HF-Sperrkreis Wiedergabe

Das Spannungsminimum (BIAS TRAP) muss <100 mV sein.

Page 29, Chapter 6.4.4 RF-Traps, Reproduce

The voltage minimum (BIAS TRAP) must be smaller than 100 mV.

Page 29, chapitre 6.4.4 Circuit-bouchon de lecture

La tension doit être inférieure à 100 mV.

Seite 29, Kapitel 6.5 Aufnahme-Einstellungen

Der NF-Generator wird bei 1000 Hz so eingestellt, dass am Ausgang OUTPUT 155 mV anstehen.

Page 29, Chapter 6.5 Record Adjustments

Adjust audio generator with 1000 Hz to get a reading at the tape recorder's output of 155 mV.

Page 29, chapitre 6.5 Réglage en enregistrement

Régler le générateur à 1000 Hz de manière à obtenir 155 mV à la sortie OUTPUT du magnétophone.

Bedingt durch modernere Bandsorten ist diese Tabelle umfangreicher geworden:

Due to modern tape brands, the table has been enlarged:

Les nouveaux types de bande ont nécessité de compléter la tabelle:

Bandsorte Type of tape Type de bande	_U 9,5cm/s _V 3 3/4ips	_U 19cm/s _V 7 1/2ips	_U 38cm/s _V 15ips
REVOX 601	5 dB	4 dB	3 dB
REVOX 621	4,5	4	3
REVOX 631	6	6	4
SCOTCH 206	5	5	3
SCOTCH 207	5	4	3
SCOTCH 250	5	6	4
SCOTCH 256	6	6	4
AMPEX 406	6	5	4
AMPEX 407	6	5,5	4
AMPEX 456	5	6	4
AGFA PEM 368	5	5	3,5
AGFA PEM 468	6	6	3,5
AGFA PER 525	6	5,5	3
AGFA PER528	6	6	4
BASF LPR-35LH	6	5	4
BASF SPR 50LH	6	5,5	3,5
BASF LGR 30P	6	5,5	4
BASF LGR 50	6	6	4
MAXELL UD-XL	6	5	4
TDK AUDUA	6	5	4
EMI 816/817	6	6	4

Seite 30, Kapitel 6.5.4 Aufnahme-Pegel

Page 30, Chapter 6.5.4 Record Level

Page 30, chapitre 6.5.4 Niveau d'enregistrement

Die Ausgangsspannung sollte nicht 200 mV sondern 155 mV betragen (siehe Korrektur Kapitel 6.3.3).

The output voltage should be 155 mV instead of 200 mV (see correction chapter 6.3.3).

La tension de sortie passe de 200 à 155 mV (voir corrections chapitre 6.3.3).

Seite 30, Kapitel 6.6.1 Klirrfaktor (über Band), VU-Meter Eichung

Moderne Bänder können extrem hoch ausgesteuert werden. Darum wird die maximale Aussteuerung nicht mehr nach K3 definiert sondern auf 257 nWb/m bei 1000 Hz (0 VU) resp. 514 nWb/m bei 1000 Hz (0 VU + 6 dB). Die Einstellung wird über Band wie folgt vorgenommen:

- Gerät wie Bild 6.6.–74 einstellen.
- Generatorpegel am Eingang so einstellen, dass der Wert am Ausgang OUTPUT 3,1 V (+ 6 dB VU) nicht überschreitet (K3 wird nicht beachtet).
- Eingangspegel um 6 dB absenken und die VU-Meter auf 0 VU eichen (Trimpotentiometer METER CALIB., Bild 6.6.–75).
- Klirrfaktor über Band bei 0 VU + 6 dB darf 2 % nicht überschreiten.

Seite 31, Kapitel 6.6.2 Geräuschspannung über Band

- Die Geräuschspannungsmessungen beziehen sich auf Volllaussteuerung (514 nWb/m).

Seite 32, Kapitel 6.6.4 Löschkämpfung

Der Aufnahmepegel bei 1000 Hz beträgt + 6 VU (514 nWb/m).

Page 30, Chapter 6.6.1 Distortion Factor (via Tape), VU-meter Calibration

With modern tapes, an extremely high magnetization can be achieved. Therefore, maximum output level is not anymore determined with the distortion factor K3. 257 nWb/m by 1000 Hz corresponds to 0 VU (775 mV); 514 nWb/m by 1000 Hz corresponds to 0 VU + 6 dB (1.55 V). Calibrate via tape:

- Set controls per Fig. 6.6–74.
- Adjust frequency of your AF-generator according to the used bandpass filter to measure K3. Recorder's output level should not exceed 3.1 V (+ 6 dB VU). Disregard distortion K3.
- Lower generator level by 6 dB and calibrate VU-meter to display 0 VU (trimmpotentiometer METER CALIB., Picture 6.6–75).
- Distortion factor via tape by 0 VU + 6 dB ist not allowed to exceed 2 %.

Page 31, Chapter 6.6.2 Noise Voltage via Tape

Noise voltage measurements: refer to the 100 % modulation (514 nWb/m).

Page 32, Chapter 6.6.4 Erase Attenuation

The recorded reference level by 1000 Hz is + 6 VU (514 nWb/m).

Page 30, chapitre 6.6.1 Distorsion "après bande", étalonnage des VU-mètres

Les bandes modernes admettent une magnétisation beaucoup plus élevée. De ce fait le niveau maximum n'est plus défini par le taux de distorsion, mais par le niveau de référence de 257 nWb/m à 1000 Hz pour 0 VU, respectivement 514 nWb/m à 1000 Hz pour 0 VU + 6 dB. Procéder comme suit pour le réglage "après bande":

- FIGURE
- Placer les éléments de commande selon la figure 6.6–74.
 - Régler le générateur (fréquence selon le filtre passebande utilisé) de manière à obtenir un maximum de 3,1 V (+ 6 dB VU) sur la sortie OUTPUT. (Ne pas tenir compte de la distorsion).
 - Abaisser le niveau du générateur de 6 dB et régler les VU-mètres à 0 VU (potentiomètres METER CALIB., figure 6.6.–75).

Page 31, chapitre 6.6.2 Bruit de fond "après bande"

- Le niveau du bruit de fond est mesuré par rapport au niveau maximum (514 nWb/m).

Page 32, chapitre 6.6.4 Profondeur d'effacement

Le niveau de référence à l'enregistrement est à + 6 dB VU (514 nWb/m).

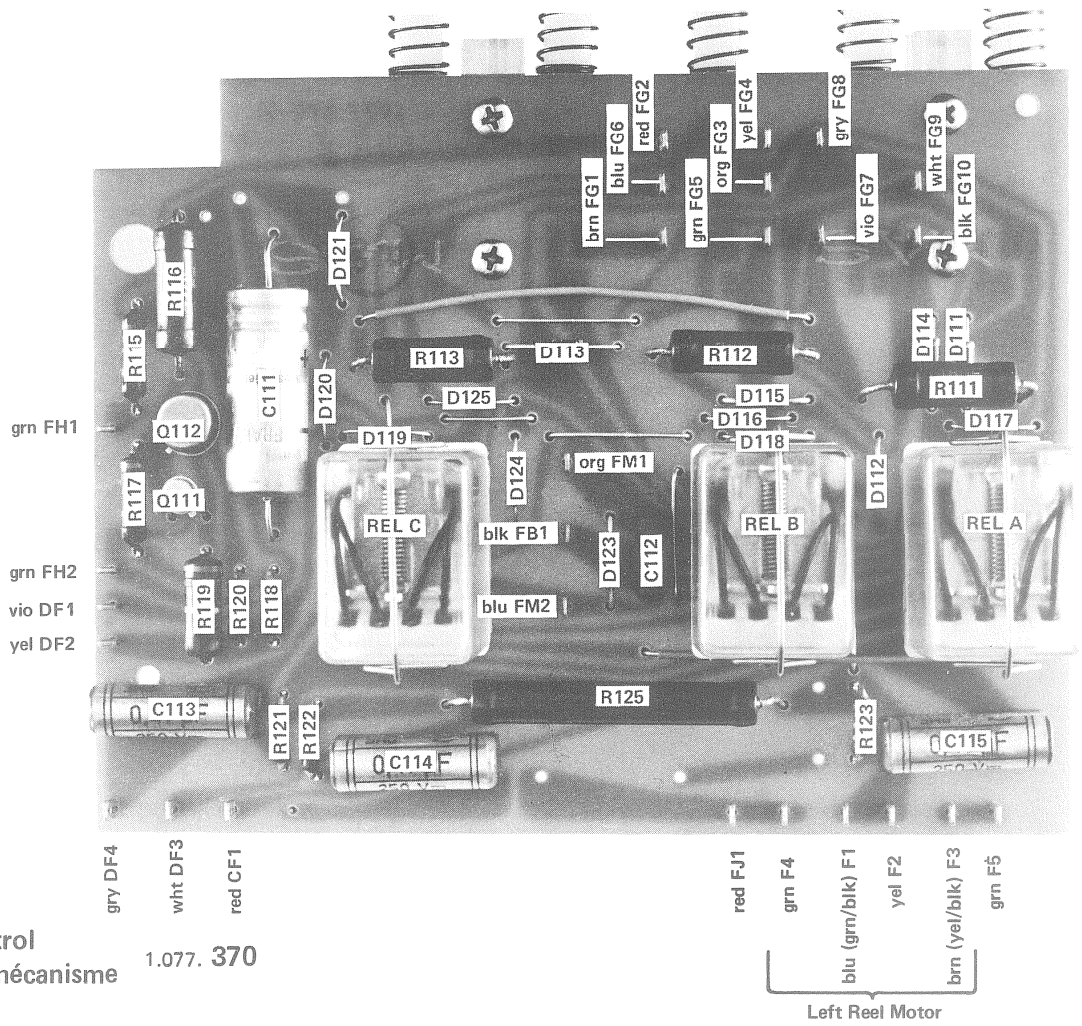

Tape Drive Control
Commande du mécanisme 1.077. 370

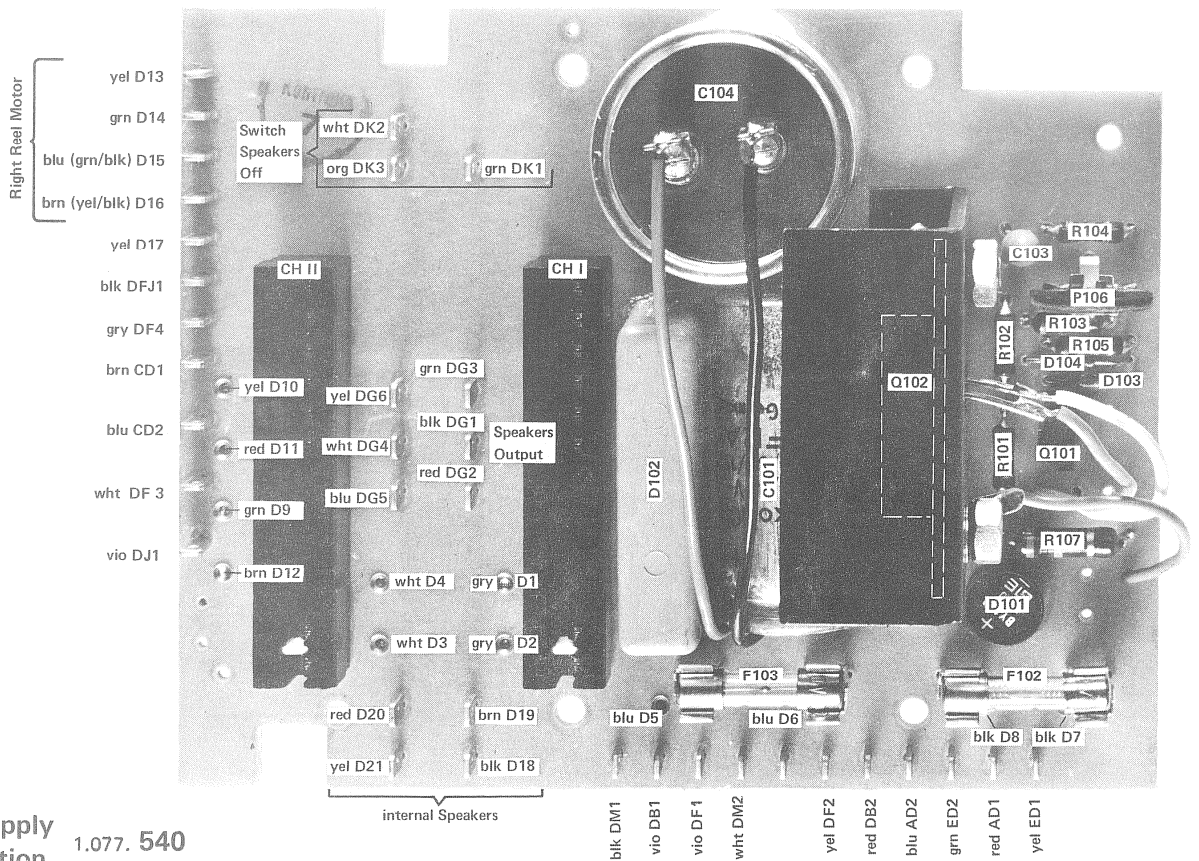

Power Supply
Alimentation 1.077. 540

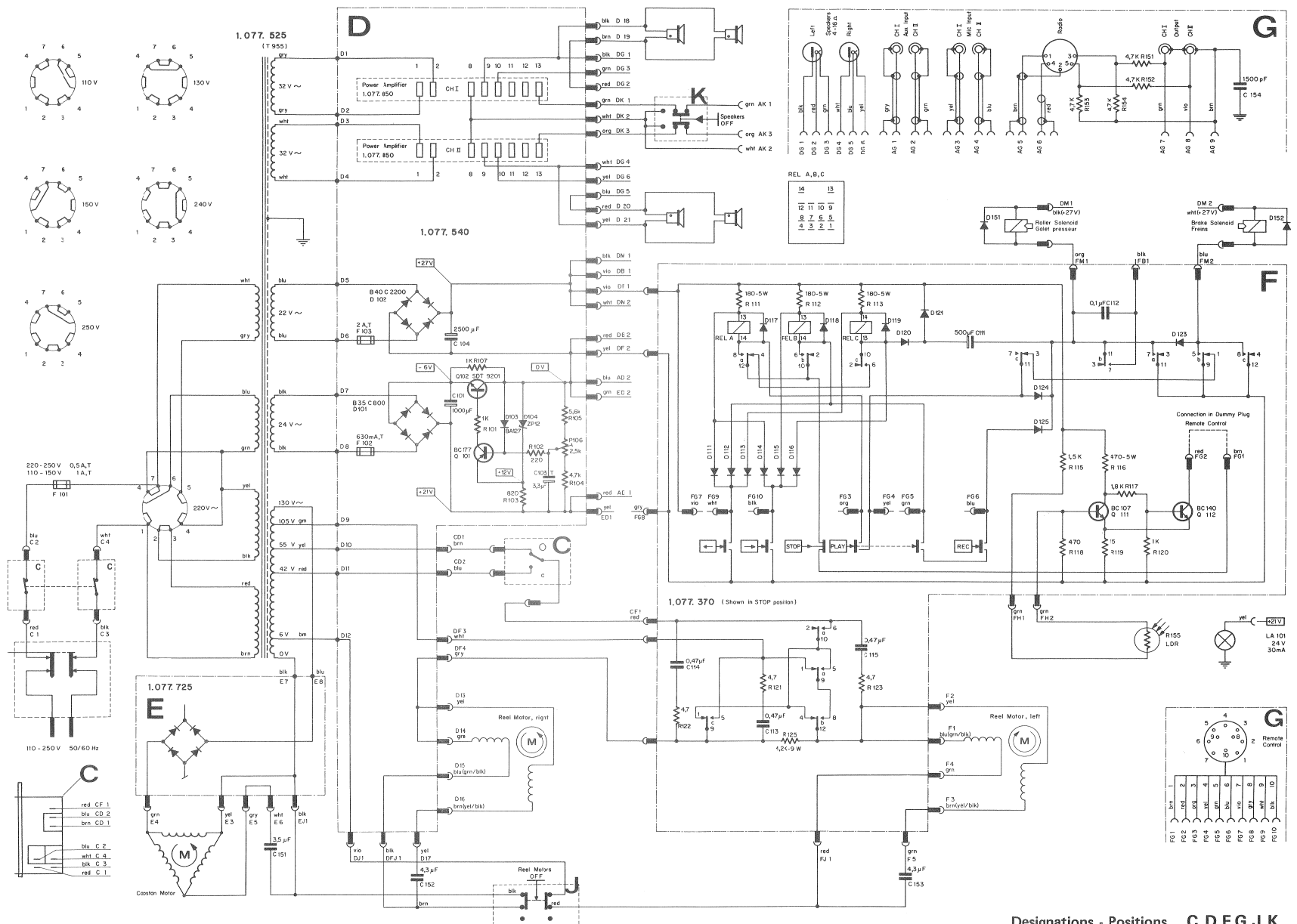

Color Code :

Code des couleurs :

red = red — rouge
org = orange — orange

yel = yellow — jaune
grn = green — vert
blu = blue — bleu
vio = violet — violet

brn = brown — brun
gry = gray — gris
blk = black — noir
wht = white — blanc

Designations - Positions C, D, F, G, J, K

Tape Drive 1.077.100
Mécanisme (1.077.370, 1.077.525, 1.077.540)

Unspecified carbon film resistors:
1/8 W – 5 %
Résistance à couche sans spécification:
1/8 W – 5 %

** Commercial types
** Type d'usage courant

Identification Position	Part Name Désignation	Type / Remarks Type / Remarques	Specifications Spécifications	Order Number Numéro de commande
	Power Supply Board Plaque alimentation	assembled complète		1.077.540
	Connector connecteur			1.077.540 – 03
	Coding Piece pièce de codage			1.077.435 – 10
Q 101	Transistor transistor	BC 177A, BC 157A		**
Q 102	Transistor transistor	SDT 9201	TO – 5	**
				**
D 101	Si–Rectifier redresseur au silicium	B 35 C 800	35 V – 800 mA	**
D 102	Si–Rectifier redresseur au silicium	B 40 C 2200	40 V – 2.2 A	**
D 103	Si–Diode diode au silicium	BA 127	50 V – 100 mA – 70°	**
D 104	Z–Diode (Planar) diode Zener (planar)	ZP 12	12 V – 5% – 400 mW	**
P 106	Trim–Potentiometer pot. ajustable	Ruwido P 76 K	2.5 k – 0.15 W – 20 %	**
R 101	Resistor résistance	carbon film à couche	1 k	**
R 102	Resistor résistance	carbon film à couche	220	**
R 103	Resistor résistance	carbon film à couche	820	**
R 104	Resistor résistance	carbon film à couche	4.7 k	**
R 105	Resistor résistance	carbon film à couche	5.6 k	**
R 107	Resistor résistance	carbon film à couche	1 k – 5% – 0.3 W	**
C 101	Capacitor condensateur	electrolytic électrolytique	1000 μ F – 35 V	**
C 103	Capacitor condensateur	tantalum au tantale	3.3 μ F – 35 V	**
C 104	Capacitor condensateur	electrolytic électrolytique	2500 μ F – 35 V	**
F 102	Fuse fusible	5 x 20 mm, slo-blo retardé	630 mA	**
F 103	Fuse fusible	5 x 20 mm, slo-blo retardé	2 A	**

Drive Control Board Plaque de commande du mécanisme		less push buttons and relays	sans touches ni relais		1.077.370	
Q 111	Transistor		BC 107 A		**	
Q 112	Transistor		BC 140 C (Siemens)		**	
D 111	Si-Diode	diode au silicium	PAB 212	50 V - 200 mA - 70°	**	
D 112	Si-Diode	diode au silicium	PAB 212	50 V - 200 mA - 70°	**	
D 113	Si-Diode	diode au silicium	PAB 212	50 V - 200 mA - 70°	**	
D 114	S-Diode	diode au silicium	PAB 212	50 V - 200 mA - 70°	**	
D 115	Si-Diode	diode au silicium	PAB 212	50 V - 200 mA - 70°	**	
D 116	Si-Diode	diode au silicium	BA 127	50 V - 100 mA - 70°	**	
D 117	Si-Diode	diode au silicium	BA 127	50 V - 100 mA - 70°	**	
D 118	Si-Diode	diode au silicium	BA 127	50 V - 100 mA - 70°	**	
D 119	Si-Diode	diode au silicium	BA 127	50 V - 100 mA - 70°	**	
D 120	Si-Diode	diode au silicium	BA 127	50 V - 100 mA - 70°	**	
D 121	Si-Diode	diode au silicium	PAB 212	50 V - 200 mA - 70°	**	
D 123	Si-Diode	diode au silicium	PAB 212	50 V - 200 mA - 70°	**	
D 124	Si-Diode	diode au silicium	BA 127	50 V - 100 mA - 70°	**	
D 125	Si-Diode	diode au silicium	BA 127	50 V - 100 mA - 70°	**	
R 111	Resistor	résistance	wire - wound	bobinée	180 - 10 % - 5 W - 70°	**
R 112	Resistor	résistance	wire - wound	bobinée	180 - 10 % - 5 W - 70°	**
R 113	Resistor	résistance	wire - wound	bobinée	180 - 10 % - 5 W - 70°	**
R 115	Resistor	résistance	carbon film	à couche	1.5 k - 10 % - 0.3 W	**
R 116	Resistor	résistance	wire - wound	bobinée	470 - 10 % - 5 W	**
R 117	Resistor	résistance	carbon film	à couche	1.8 k - 10 % - 0.3 W	**
R 118	Resistor	résistance	carbon film	à couche	470	**
R 119	Resistor	résistance	carbon film	à couche	15 - 10 % - 0.5 W	**
R 120	Resistor	résistance	carbon film	à couche	1 k	**
R 121 - R 123	Resistor	résistance	carbon comp.	agglomérée	4.7	**
R 125	Resistor	résistance	wire - wound	bobinée	1.2 K - 5 % - 9 W - 70°	**
C 111	Capacitor	condensateur	electrolytic	électrolytique	500 µF - 35 V	**
C 112	Capacitor	condensateur	polyester	au polyester	0.1 µF - 20 % - 100 V	**
C 113 - C 115	Capacitor	condensateur	metallized paper	au papier métallisé	0.47 µF - 150 V	**
REL A - REL C	Relay	relais	4 x switch contacts 120 V~ / 1 A / 4 contacts inverseurs		12 V - 180 Ω	56. 99.0103
	Socket	sole	for relay	pour relais		56. 99.0104
	Strap	ressort de maintien	for relay	pour relais		56. 99.0105
	Housing, Contact	Slides/boîtier des curseurs	plexi	plexiglas		1.077.360 - 01
	Slide, Contact	curseur de contact	5 pieces			1.077.365 - 01
	Spring, Reset	ressort de rappel	5 pieces			1.077.360 - 02
	Lock, spring	arrêt de ressort	5 pieces			1.077.360 - 03
	Spring, Contact	contact à ressort	6 pieces			1.010.001.55
	Tape Drive	Mécanisme	assembled	complète		1.077.100
	Power Transformer, assembled	Transformateur d'alimentation complet	T 955			1.077.525
	Voltage Selector	sélecteur de tension	Philberth			53. 03.0126
	Fuse Element	porte - fusible				53. 03.0113
F 101	Fuse	fusible	5 x 20 mm, slo-blo	retardé	220 - 250 V - 0.5 A, T	**
F 101	Fuse	fusible	5 x 20 mm, slo-blo	retardé	110 - 150 V - 1 A, T	**
C 151	Capacitor	condensateur	MP (Rifa)	papier métallisé	3.5 µF - 10 % - 220 V	59. 99.0451
C 152 C 153	Capacitor	condensateur	MP (Rifa)	papier métallisé	4.3 µF - 10 % - 220 V	59. 99.0452
C 154	Capacitor	condensateur	ceramic	céramique	1500 pF - 10 % - 50 V	**
R 151 - R 154	Resistor	résistance	carbon film	à couche	4.7 k	**
R 155	Photoelectric Resistor	photorésistance	LDR (Philips / Valvo)			57. 99.0135
			2322.600.94001			
LA 101	Lamp	lampe	glass socket	socle en verre	24 V - 30 mA	51. 02.0140
D 151	Si-Diode	diode au silicium	PAB 212		50 V - 200 mA - 70°	**
D 152	Si-Diode	diode au silicium	BA 127		50 V - 100 mA - 70°	**

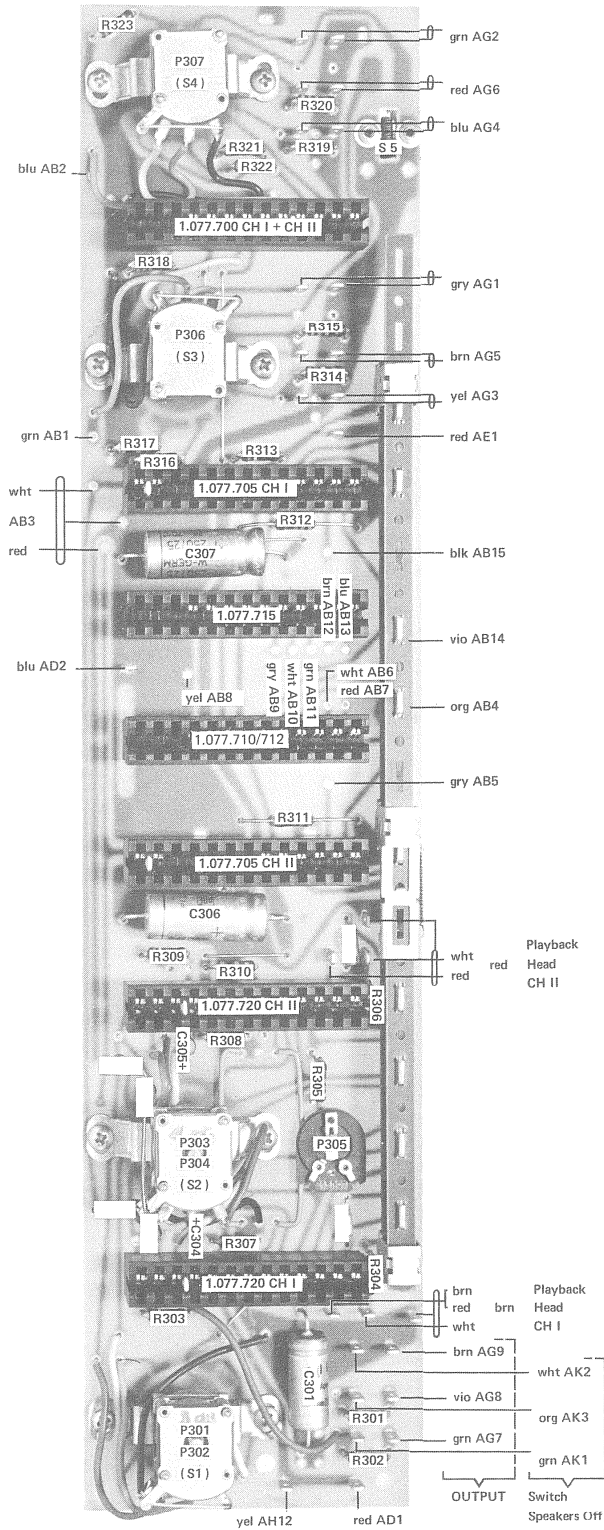

Switch Board
Plaque des commutateurs 1.077. 435

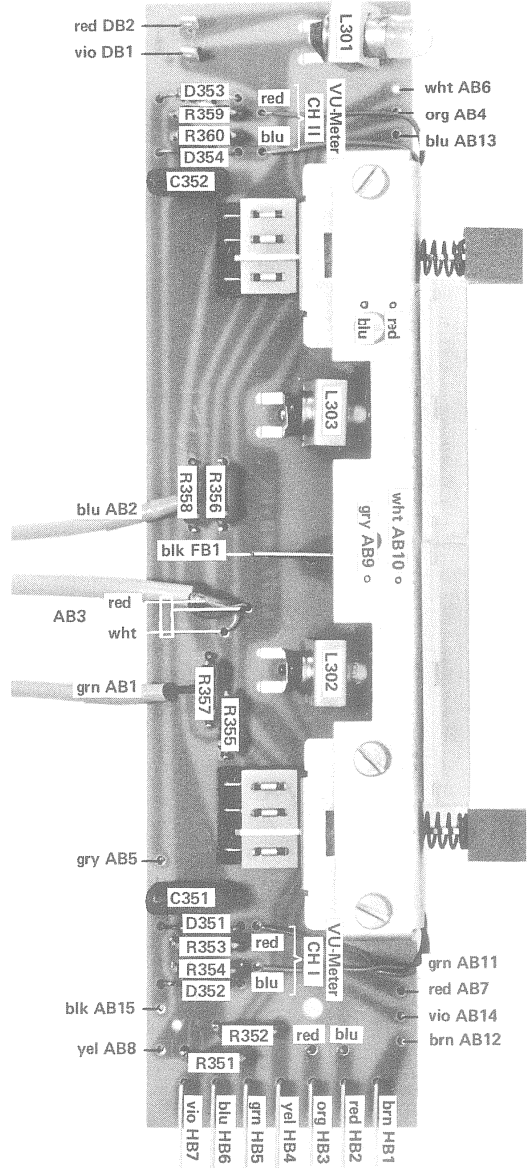

VU - Meter Board
Plaque des VU - mètres 1.077. 480

Color Code :
Code des couleurs :

red	=	red	—	rouge
org	=	orange	—	orange
yel	=	yellow	—	jaune
grn	=	green	—	vert
blu	=	blue	—	bleu
vio	=	violet	—	violet
brn	=	brown	—	brun
gry	=	gray	—	gris
blk	=	black	—	noir
wht	=	white	—	blanc

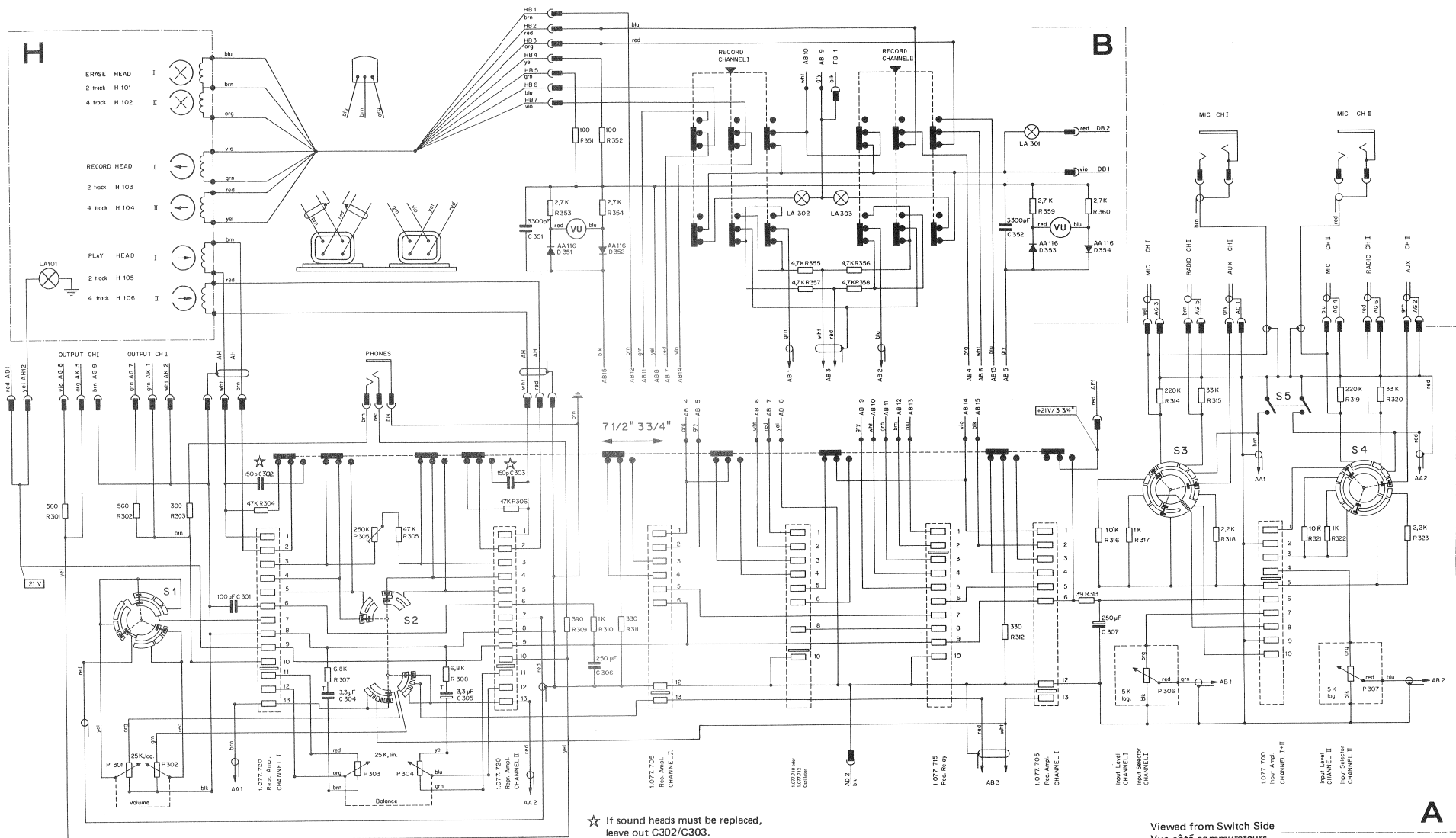

★ If sound heads must be replaced, leave out C302/C303.

Viewed from Switch Side
Vue côté commutateurs

A

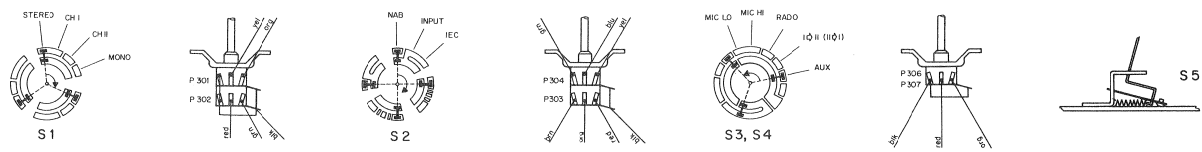

Designations - Positions A,B,H

VU-Meter Board
Plaque des VU-mètres 1.077.480

Switch Board
Plaque des commutateurs 1.077.435

Unspecified carbon film resistors:
1/8 W - 5 %
Résistance à couche sans spécification:
1/8 W - 5 %

** Commercial types
** Type d'usage courant

Identification Position	Part Name Désignation	Type / Remarks Type / Remarques	Specifications Spécifications	Order Number Numéro de commande
	Switch Board Plaque commutateurs	assembled complète		1.077.435
	Connector connecteur	1 piece (for / pour 1.077.700)		1.077.435 - 05
	Connector connecteur	2 pieces (for / pour 1.077.705)		1.077.435 - 03
	Connector connecteur	1 piece (for / pour 1.077.715)		1.077.435 - 06
	Connector connecteur	1 piece (for / pour 1.077.710/712)		1.077.435 - 04
	Connector connecteur	2 pieces (for / pour 1.077.720)		1.077.435 - 02
	Coding Piece pièce de codage	7 pieces		1.077.435 - 10
	Switch Slide curseur à contacts			1.077.435 - 07
S 1	Circuit Board Switch, 4 / 9 Commutateur pour circuit imprimé	Playback mode switch, assembled Sélecteur du mode de reproduction complet		1.011.400
S 2	Circuit Board Switch, 3 / 10 Commutateur pour circuit imprimé	Before / After - tape switch, assembled Commutateur lecture - directe, complet		1.011.300
S 3 / S 4	Circuit Board Switch, 5 / 8 Commutateur pour circuit imprimé	Input selector, assembled Sélecteur d'entrée, complet		1.011.500
S 5	Playback Cut-Off Switch Contact de coupure de la lecture	assembled complet		1.077.437
P 301 P 302	Potentiometer potentiomètre	Volume, assembled complet		1.077.430 - 09
P 303 P 304	Potentiometer potentiomètre	Balance, assembled complet		1.077.430 - 08
P 306 P 307	Potentiometer potentiomètre	Input Level, assembled complet		1.077.430 - 07
P 305	Trim-Potentiometer pot. ajustable	Ruwido S 76 K	250 k - 20 % - 0.15 W	**
R 301	Resistor résistance	carbon film à couche	560	**
R 302	Resistor résistance	carbon film à couche	560	**
R 303	Resistor résistance	carbon film à couche	390	**
R 309	Resistor résistance	carbon film à couche	390	**
R 304 - R 306	Resistor résistance	carbon film à couche	47 k	**
R 307 R 308	Resistor résistance	carbon film à couche	6.8 k	**
R 310 R 317	Resistor résistance	carbon film à couche	1 k	**
R 311 R 312	Resistor résistance	carbon film à couche	330	**
R 313	Resistor résistance	carbon film à couche	39	**
R 314 R 319	Resistor résistance	carbon film à couche	220 k	**
R 315 R 320	Resistor résistance	carbon film à couche	33 k	**
R 316 R 321	Resistor résistance	carbon film à couche	10 k	**
R 318 R 323	Resistor résistance	carbon film à couche	2.2 k	**
R 322	Resistor résistance	carbon film à couche	1 k	**
C 301	Capacitor condensateur	electrolytic électrolytique	100 µF - 25 V	**
C 304 C 305	Capacitor condensateur	tantalum au tantale	3.3 µF - 15 V	**
C 306 C 307	Capacitor condensateur	electrolytic électrolytique	250 µF - 25 V	**
	VU-Meter Board Plaque des VU-mètres	assembled complète		1.077.480
	VU-Meter VU-mètres	2 pieces		1.077.470 - 02
	Push-Button Switch commutateur à touche	Record pre-selector présélection enreg.		1.077.475 - 02
L 301 - L 303	Lamp Socket socle de lampe	3 pieces		1.077.480 - 02
L 301	Spring Contact ressort de contact			1.077.480 - 03
L 302 L 303	Spring Contact ressort de contact	2 pieces		1.077.480 - 04
L 301 - L 303	Lamp lampe	3 pieces	36 V - 50 mA	51. 02.0104
D 351 - D 354	Ge-Diode diode au germanium	AA 116 - AA 119		**
R 351 R 352	Resistor résistance	carbon film à couche	100	**
R 353 R 354	Resistor résistance	carbon film à couche	2.7 k	**
R 359 R 360	Resistor résistance	carbon film à couche	2.7 k	**
R 355 - R 358	Resistor résistance	carbon film à couche	4.7 k	**
C 351 C 352	Capacitor condensateur	polyester au polyester	3300 pF - 400 V	**

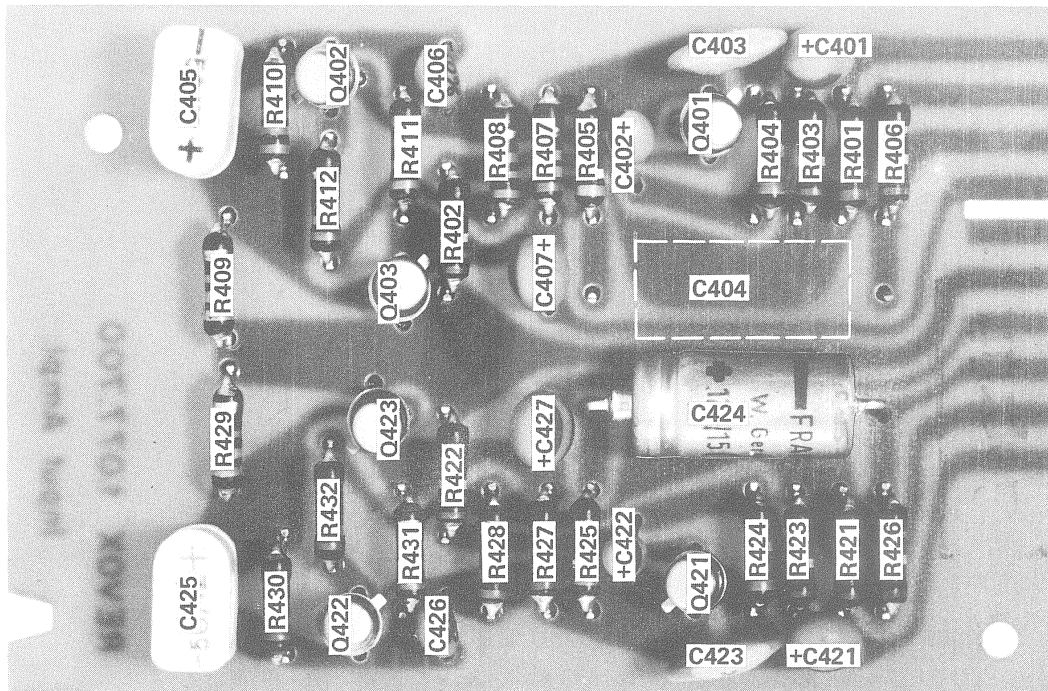

Input Amplifier
 Amplificateur d'entrée 1.077. 700

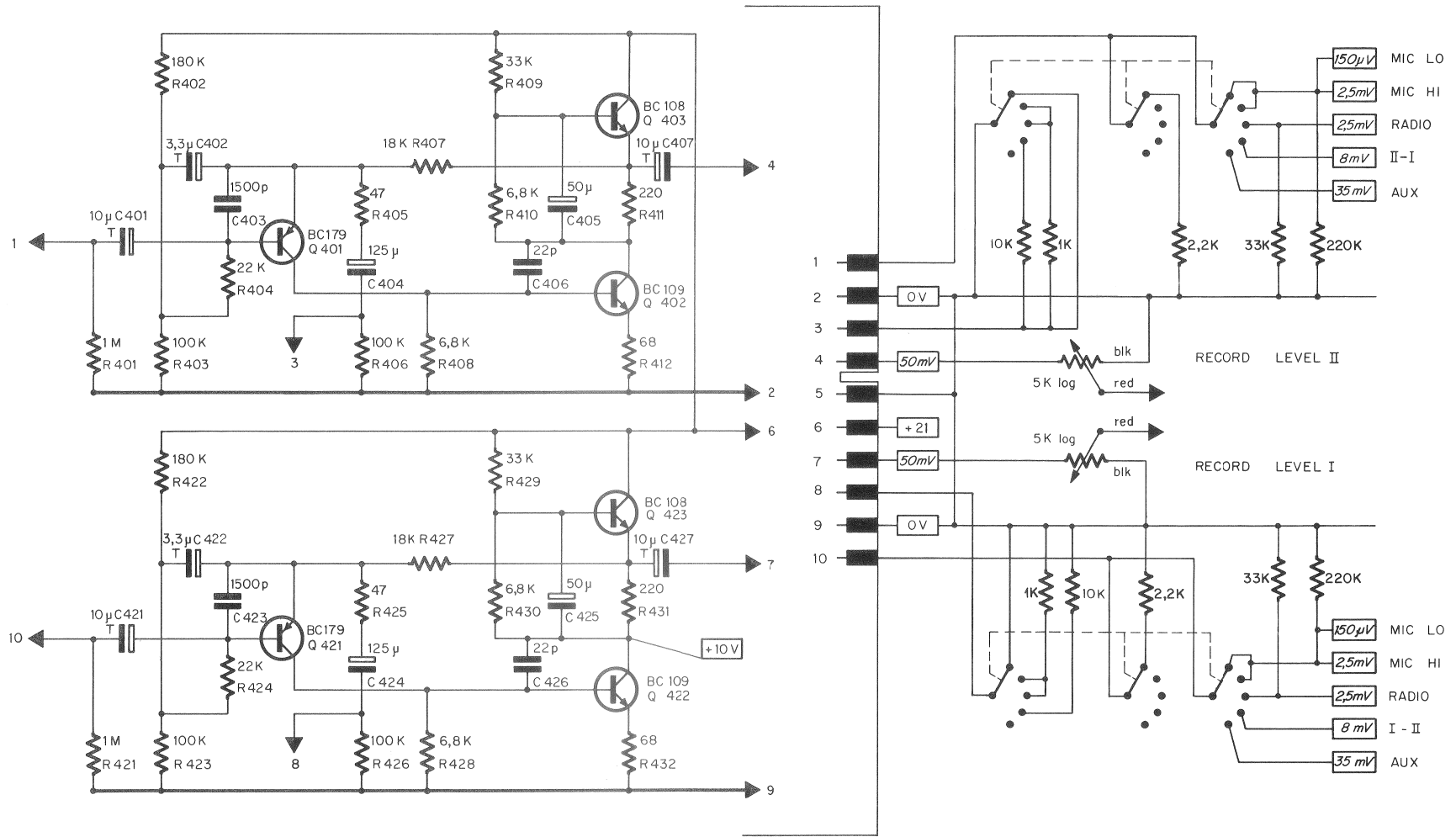

Input Amplifier
Amplificateur d'entrée 1.077. 700

Unspecified carbon film resistors:
1/8 W – 5 %
Résistance à couche sans spécification:
1/8 W – 5 %

** Commercial types
** Type d'usage courant

Identification Position	Part Name Désignation	Type / Remarks Type / Remarques	Specifications Spécifications	Order Number Numéro de commande
	Input Amplifier Amplificateur d'entrée	Board assembled plaquette complète		1.077.700
Q 401 Q 421	Transistor	BC 179 B, BC 159 B		* *
Q 402 Q 422	Transistor	BC 109 C, BC 149 C		* *
Q 403 Q 423	Transistor	BC 108 B, BC 148 B		* *
R 401 R 421	Resistor résistance	carbon film à couche	1 M	* *
R 402 R 422	Resistor résistance	carbon film à couche	180 k	* *
R 403 R 423	Resistor résistance	carbon film à couche	100 k	* *
R 404 R 424	Resistor résistance	carbon film à couche	22 k	* *
R 405 R 425	Resistor résistance	carbon film à couche	47	* *
R 406 R 426	Resistor résistance	carbon film à couche	100 k	* *
R 407 R 427	Resistor résistance	carbon film à couche	18 k	* *
R 408 R 428	Resistor résistance	carbon film à couche	6.8 k	* *
R 409 R 429	Resistor résistance	carbon film à couche	33 k	* *
R 410 R 430	Resistor résistance	carbon film à couche	6.8 k	* *
R 411 R 431	Resistor résistance	carbon film à couche	220	* *
R 412 R 432	Resistor résistance	carbon film à couche	68 k	* *
C 401 C 421	Capacitor condensateur	tantalum au tantale	10 μ F – 15 V	* *
C 402 C 422	Capacitor condensateur	tantalum au tantale	3.3 μ F – 15 V	* *
C 403 C 423	Capacitor condensateur	ceramic céramique	1500 pF – 10 % – 50 V	* *
C 404 C 424	Capacitor condensateur	electrolytic électrolytique	125 μ F – 3 V	* *
C 405 C 425	Capacitor condensateur	electrolytic électrolytique	50 μ F – 3 V	* *
C 406 C 426	Capacitor condensateur	ceramic céramique	22 pF – 10 % – 50 V	* *
C 407 C 427	Capacitor condensateur	tantalum au tantale	10 μ F – 15 V	* *

Frequency Characteristic, Record Amplifier 7 1/2 ips
 Courbe de réponse de l'ampli d'enregistrement à 7 1/2 in/s

Test Set-up: (pull oscillator out before measuring)
 Dispositif de mesure: (retirer l'oscillateur avant la mesure)

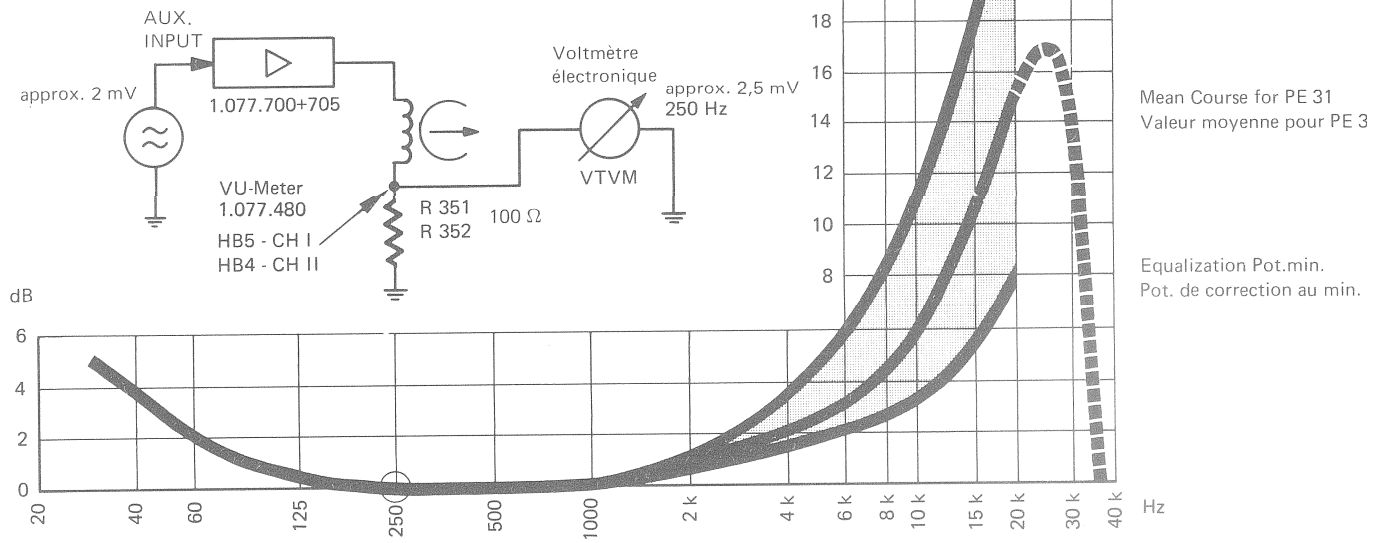

Frequency Characteristic, Record Amplifier 3 3/4 ips
 Courbe de réponse de l'ampli d'enregistrement à 3 3/4 in/s

Test Set-up as above
 Dispositif de mesure comme ci-dessus

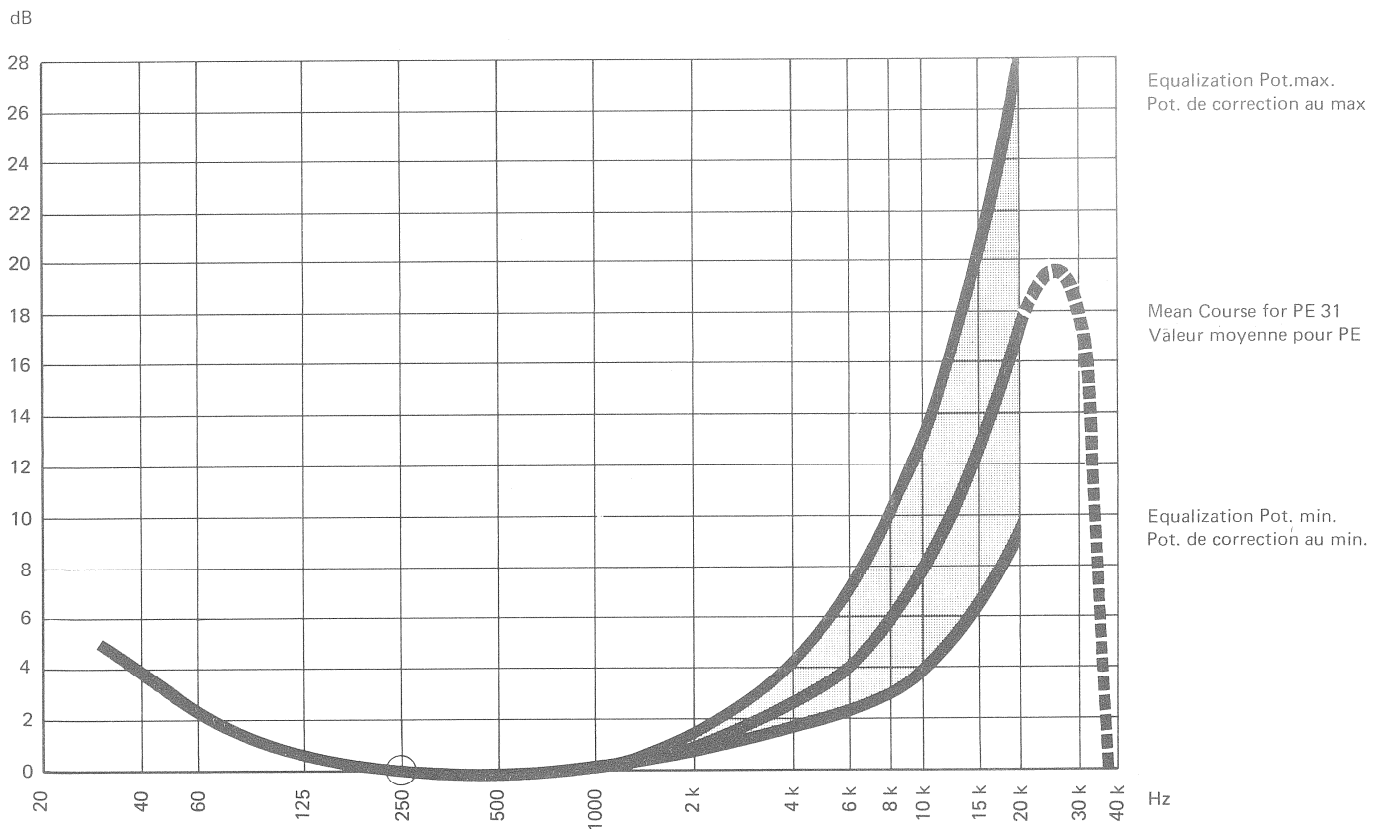

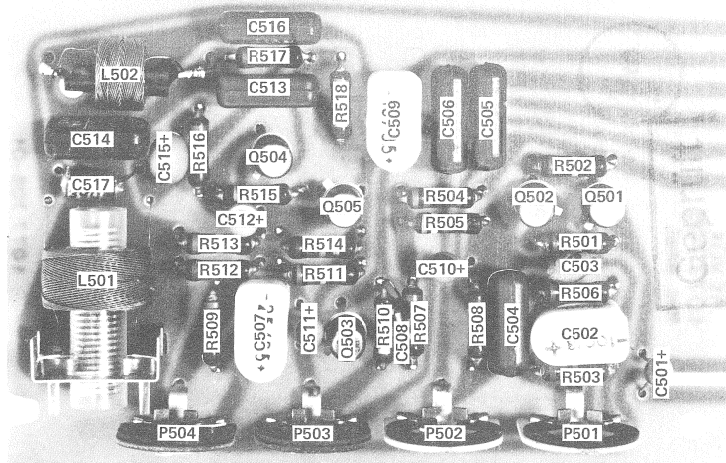
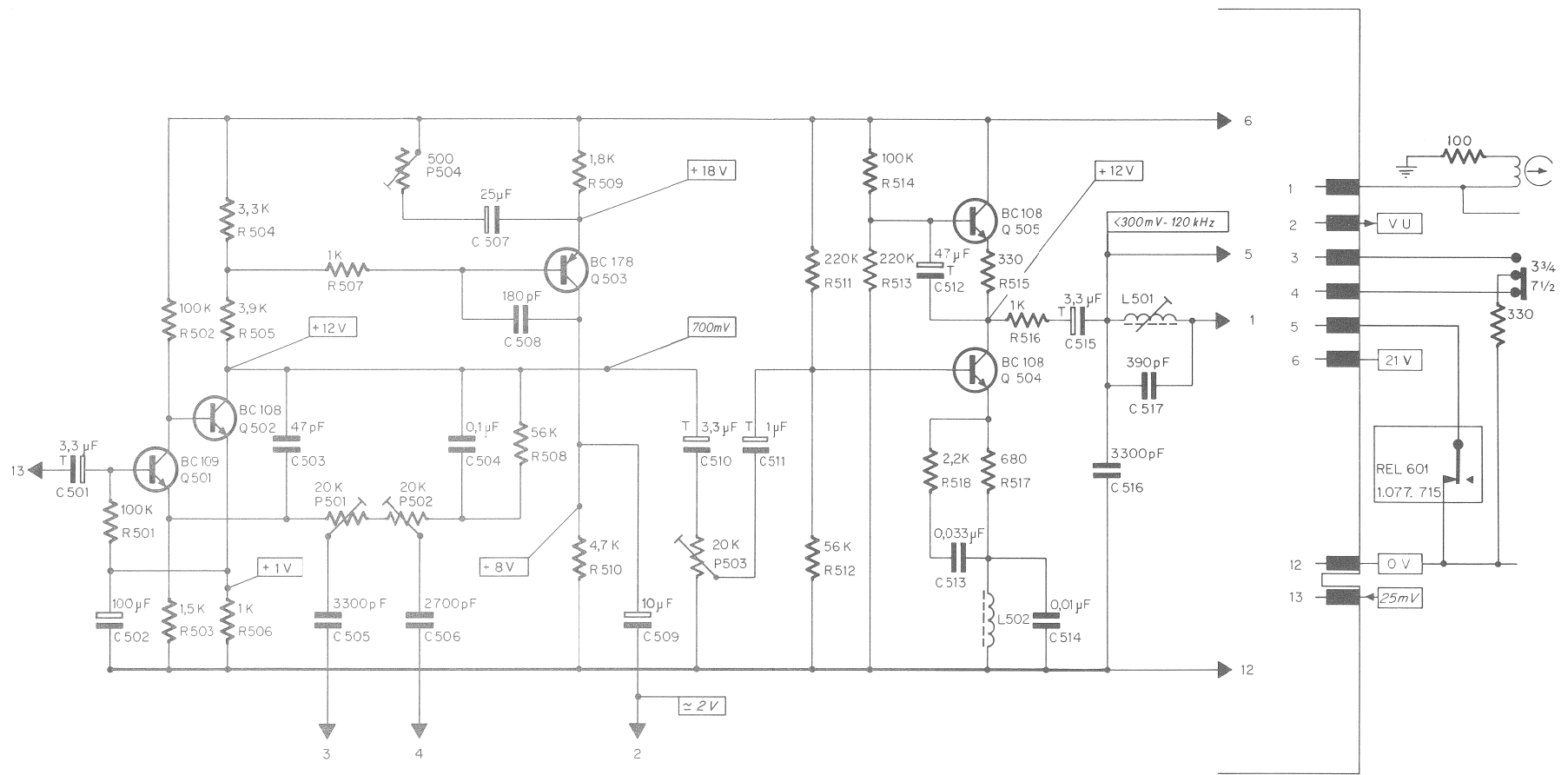

Equalization NAB 7 1/2-15 '' (1.077.782)

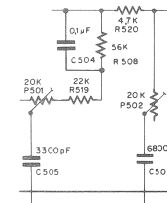

Equalization IEC 7 1/2-15 '' (1.077.780)

- R502 change to 150 k
- C504/R508 replaced by wire bridge
- R518 removed

Record Amplifier 1.077.705
 Amplificateur d'enregistrement

Unspecified carbon film resistors:
1/8 W - 5 %
Résistance à couche sans spécification :
1/8 W - 5 %

** Commercial types
** Type d'usage courant

Identification Position	Part Name Désignation	Type / Remarks Type / Remarques	Specifications Spécifications	Order Number Numéro de commande
	Record Amplifier Amplificateur d'enregistrement	Board assembled plaquette complète		1.077.705
Q 501	Transistor	BC 109 B, BC 149 B		**
Q 502	Transistor	BC 108 B, BC 148 B		**
Q 503	Transistor	BC 178 A, BC 168 A		**
Q 504 Q 505	Transistor	BC 108 B, BC 148 B		**
P 501 P 502	Trim-Potentiometer pot. ajustable	Ruwido P 76 K	20 k - 10 % - 0.15 W	**
P 503	Trim-Potentiometer pot. ajustable	Ruwido P 76 K	20 k - 20 % - 0.15 W	**
P 504	Trim-Potentiometer pot. ajustable	Ruwido P 76 K	500 - 20 % - 0.15 W	**
R 501 R 502	Resistor résistance	carbon film à couche	100 k	**
R 503	Resistor résistance	carbon film à couche	1.5 k	**
R 504	Resistor résistance	carbon film à couche	3.3 k	**
R 505	Resistor résistance	carbon film à couche	3.9 k	**
R 506	Resistor résistance	carbon film à couche	1 k	**
R 507	Resistor résistance	carbon film à couche	1 k	**
R 508	Resistor résistance	carbon film à couche	56 k	**
R 509	Resistor résistance	carbon film à couche	1.8 k	**
R 510	Resistor résistance	carbon film à couche	4.7 k	**
R 511 R 513	Resistor résistance	carbon film à couche	220 k	**
R 512	Resistor résistance	carbon film à couche	56 k	**
R 514	Resistor résistance	carbon film à couche	100 k	**
R 515	Resistor résistance	carbon film à couche	330	**
R 516	Resistor résistance	carbon film à couche	1 k	**
R 517	Resistor résistance	carbon film à couche	680	**
R 518	Resistor résistance	carbon film à couche	2.2 k	**
C 501 C 510	Capacitor condensateur	tantalum au tantale	3.3 μ F - 15 V	**
C 502	Capacitor condensateur	electrolytic électrolytique	100 μ F - 3 V	**
C 503	Capacitor condensateur	ceramic céramique	47 pF - 10 % - 50 V	**
C 504	Capacitor condensateur	polyester au polyester	0.1 μ F - 10 % - 100 V	**
C 505	Capacitor condensateur	polyester au polyester	3300 pF - 10 % - 400 V	**
C 506	Capacitor condensateur	polyester au polyester	2700 pF - 10 % - 400 V	**
C 507	Capacitor condensateur	electrolytic électrolytique	25 μ F - 25 V	**
C 508	Capacitor condensateur	polystyrene au polystyrène	180 pF - 10 % - 160 V	**
C 509	Capacitor condensateur	electrolytic électrolytique	10 μ F - 35 V	**
C 511	Capacitor condensateur	tantalum au tantale	1 μ F - 15 V	**
C 512	Capacitor condensateur	tantalum au tantale	47 μ F - 3 V	**
C 513	Capacitor condensateur	polyester au polyester	0.033 μ F - 10 % - 250 V	**
C 514	Capacitor condensateur	polyester au polyester	0.01 μ F - 10 % - 160 V	**
C 515	Capacitor condensateur	tantalum au tantale	3.3 μ F - 30 V	**
C 516	Capacitor condensateur	polyester au polyester	3300 pF - 10 % - 400 V	**
C 517	Capacitor condensateur	polystyrene au polystyrène	390 pF - 5 % - 160 V	**
L 501	Choke Coil bobine d'arrêt	assembled complète		1.077.750
L 502	Choke Coil MPX bobine d'arrêt MPX	assembled complète		1.077.707

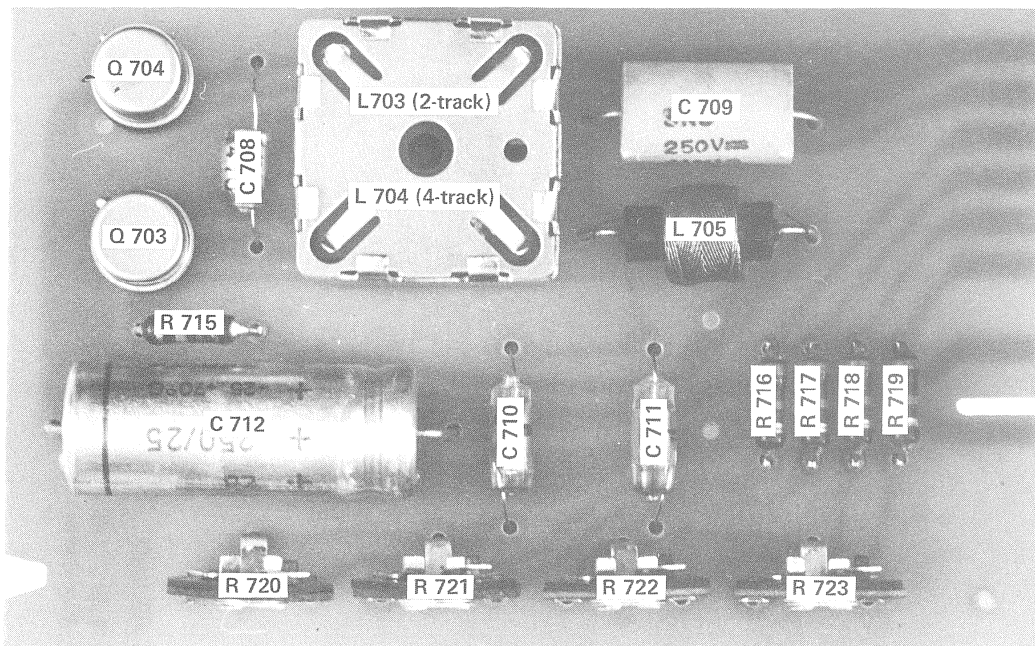

Oscillator 1.077.712
Oscillateur

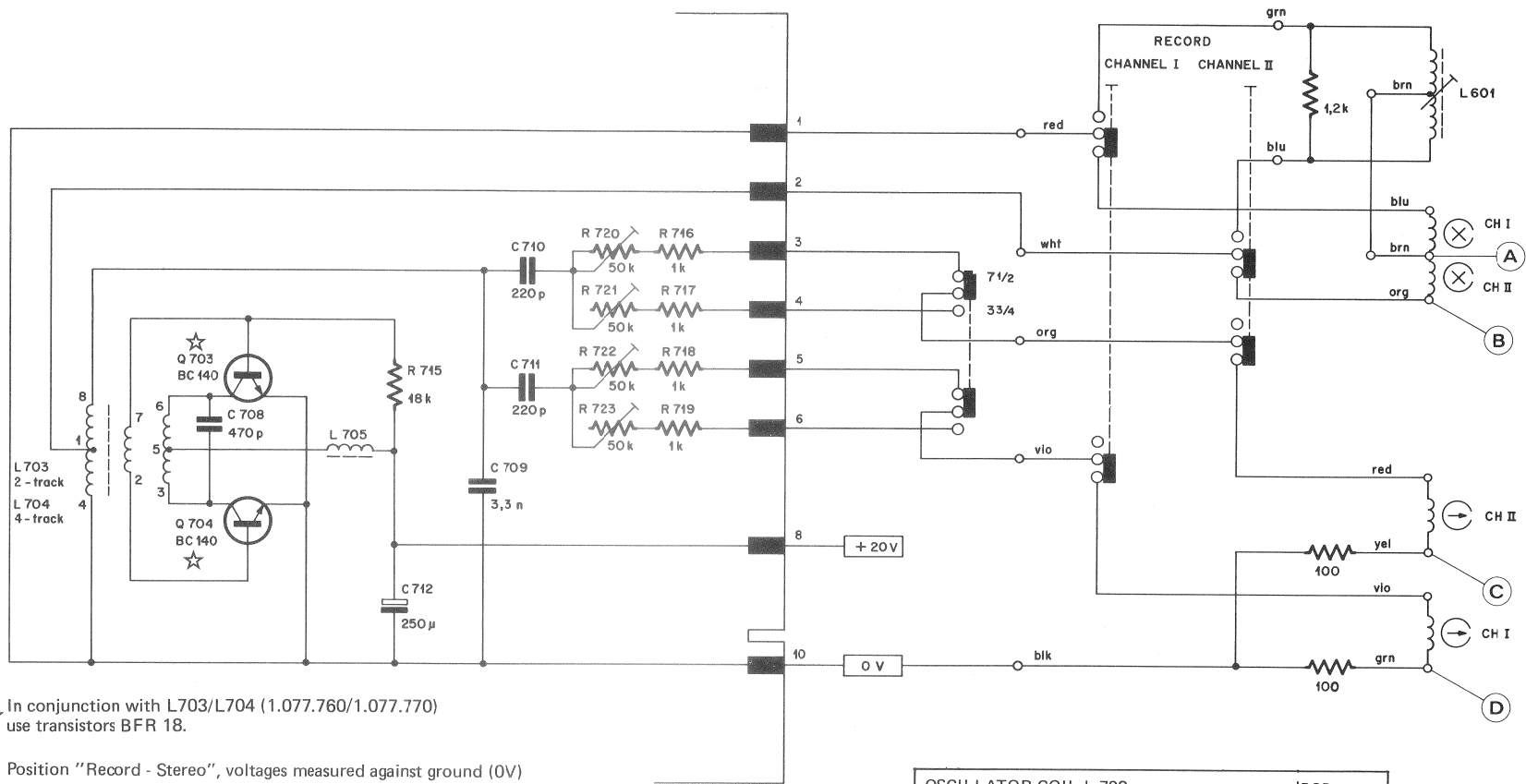

★ In conjunction with L703/L704 (1.077.760/1.077.770) use transistors BFR 18.

Position "Record - Stereo", voltages measured against ground (0V)
 Position "enregistrement stéréo", tensions par rapport à la masse (0V)

Test points Points de mesure	2 - Track 2 - pistes	4 - Track 4 pistes
(A)	approx. 22V/120 kHz	approx. 18V/120 kHz
(B)	approx. 44V/120 kHz	approx. 36V/120 kHz
(C) + (D)	500 mV/120 kHz 50 mV/ 1 kHz*	400 mV/120 kHz 40 mV/ 1 kHz*

OSCILLATOR COIL L 703		PCB
1.022.110 (older version)	no indication	1.077.710
1.077.760	red point on surface	1.077.712
OSCILLATOR COIL L 704		PCB
1.022.112 (older version)	black line on surface	1.077.730
1.077.770	yellow point on surface	1.077.731

Test values (C) and (D) depend on type and speed of tape; they are to be considered nominal.

Les tensions aux points (C) et (D) diffèrent suivant le type et la vitesse de la bande; les valeurs indiquées sont nominales.

* AF - Test (oscillator pulled out), full modulation
 * mesure BF (oscillateur retiré), modulation à 0 dB

Oscillator
Oscillateur 1.077.712

Identification Position	Part Name Désignation		Type/Remarks Type/Remarques		Unspecified carbon film resistors: 1/8 W – 5 %	Order Number Numéro de commande
					Résistances à couche sans spécification: 1/8 W – 5 %	
	Oscillator Board	Plaque oscillateur	2-track, assembled	2 pistes, complète	red dot on oscillator coil point rouge sur bobin. oscill.	1.077.712
			4-track, assembled	4 pistes, complète	yellow dot on oscillator coil point jaune sur bobin. oscill.	1.077.731
Q 703 – Q 704	Transistor		BC 140 - 10			**
R 715	Resistor	résistance	carbon film	à couche	18 k	**
R 716 – R 719	Resistor	résistance	carbon film	à couche	1 k	**
R 720 – R 723	Trim-potentiometer	pot. ajustable	carbon type	au carbone	50 k – 20 % – 0,15 W	**
C 708	Capacitor	condensateur	polystyrol	au polystyrol	470 pF – 5 % – 160 V	**
C 709	Capacitor	condensateur	polystyrene	au polystyrène	3,3 nF – 1 % – 125 V	**
C 710 – C 711	Capacitor	condensateur	polystyrol	au polystyrol	220 pF – 5 % – 160 V	**
C 712	Capacitor	condensateur	electrolytic	électrolytique	250 µF – 25 V	**
L 703	Oscillator coil	bobinage oscillateur	2-track, assembled	2 pistes, complète		1.022.110
L 704	Oscillator coil	bobinage oscillateur	4-track, assembled	4 pistes, complète		1.022.112
L 705	Choke coil	bobine d'arrêt	assembled	complète		1.077.707

**Commercial types
**Type d'usage courant

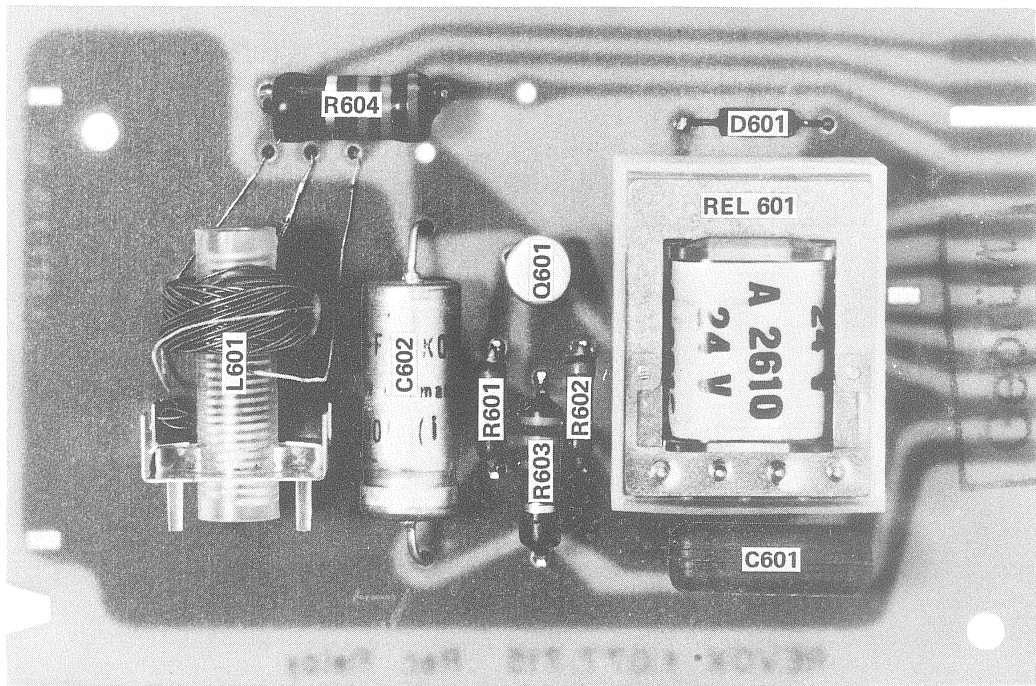

Record Relay 1.077. 715
Relais d'enregistrement

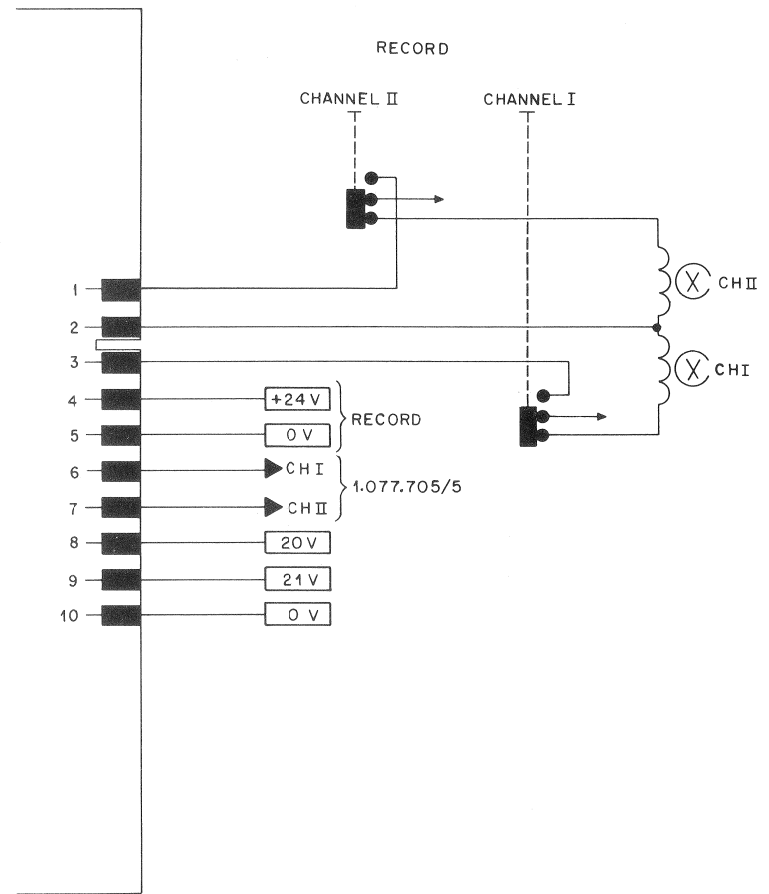
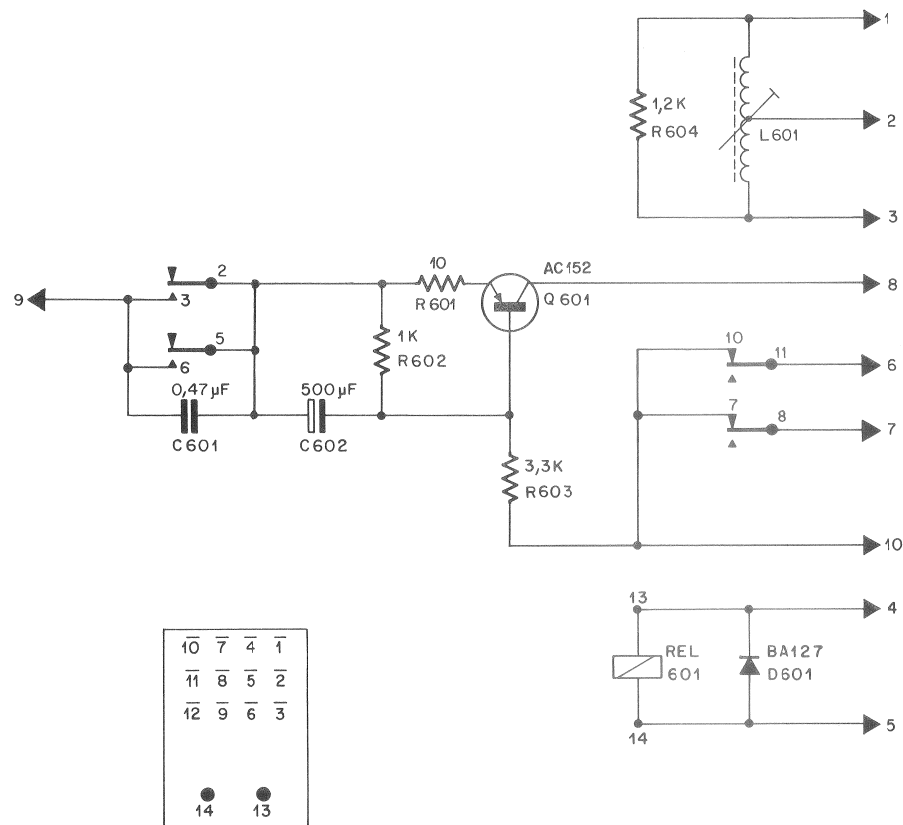

Record Relay
Relais d'enregistrement 1.077.715

Unspecified carbon film resistors:

1/8 W – 5 %

Résistance à couche sans spécification:

1/8 W – 5 %

** Commercial types

** Type d'usage courant

Identification Position	Part Name Désignation	Type / Remarks Type / Remarques	Specifications Spécifications	Order Number Numéro de commande
	Record Relay Relais d'enregistrement	Board assembled plaquette complète		1.077.715
Q 601	Transistor	AC 128, AC 152		* *
D 601	Si-Diode	diode au silicium	50 V – 100 mA	* *
R 601	Resistor	carbon film á couche	10	* *
R 602	Resistor	carbon film à couche	1 k	* *
R 603	Resistor	carbon film à couche	3.3 k – 10 % – 0,3 W	* *
R 604	Resistor	carbon film à couche	approx. 1.2 k – 0.5 W	* *
C 601	Capacitor	polyester au polyester	0.47 µF – 20 % – 100 V	* *
C 602	Capacitor	electrolytic électrolytique	500 µF – 3 V	* *
REL 601	Relay	ITT PZ 4/A 2 610 (24)		56. 04.0121
L 601	Dummy Head	assembled complète		1.077.755

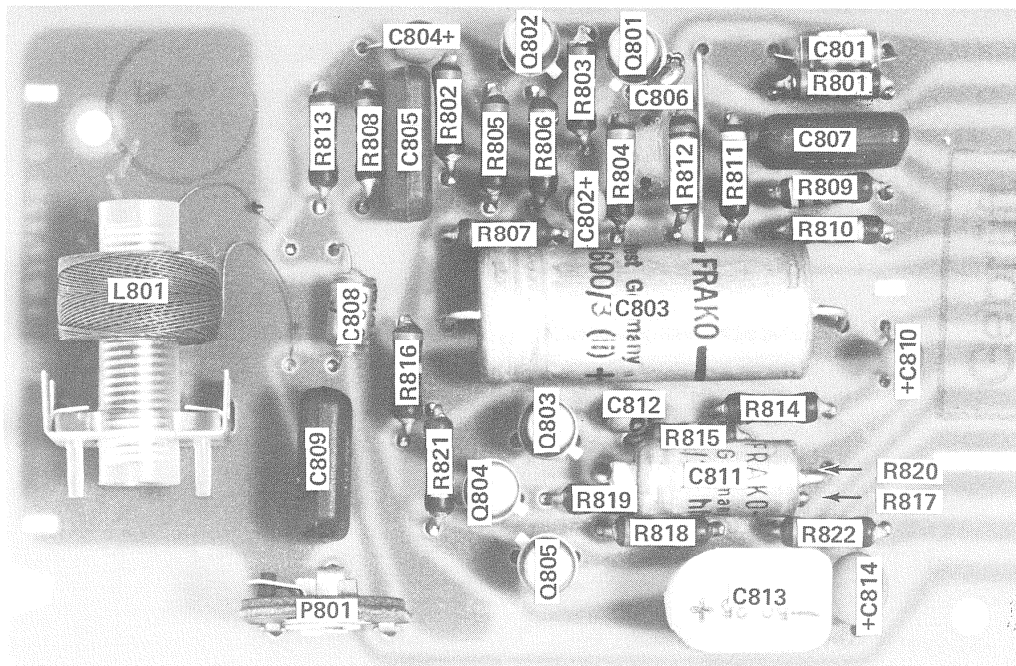

Playback and Drive Amplifier
Amplificateurs de lecture et de ligne 1.077. 720

Frequency Characteristic, Playback Amplifier (current driven)
 Courbe de réponse de l'ampli de lecture (générateur à courant constant)

Test Set-up :
 Dispositif de mesure :

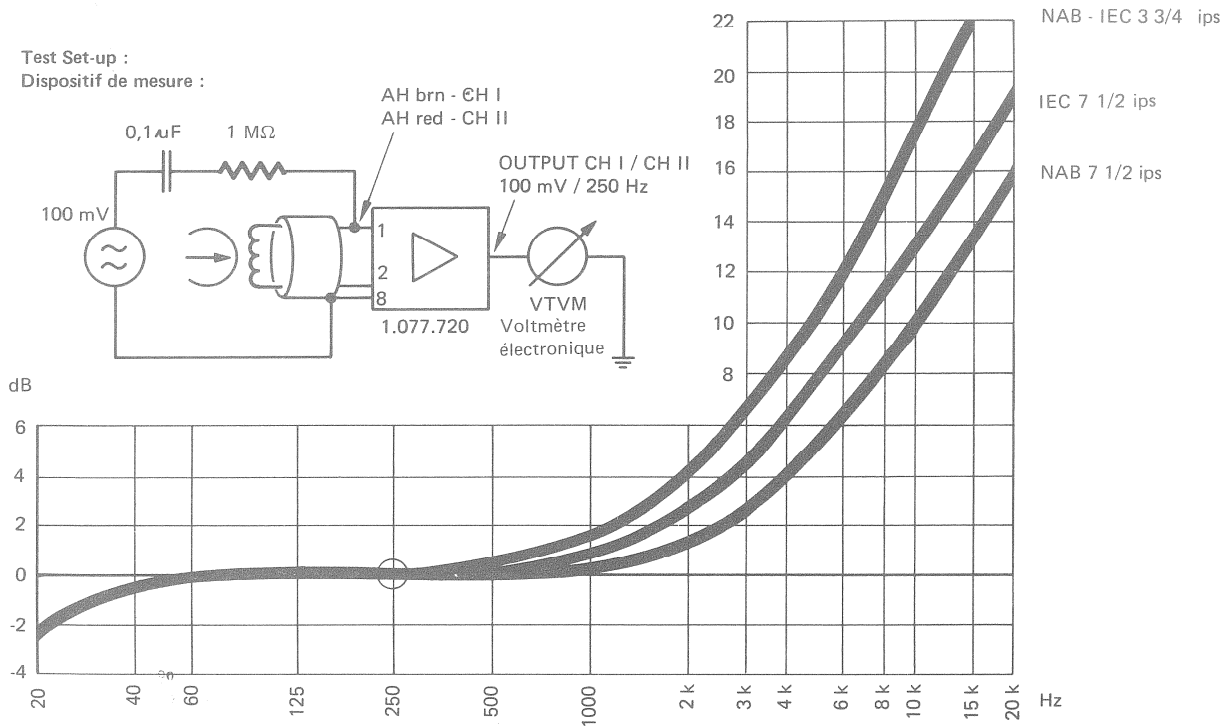
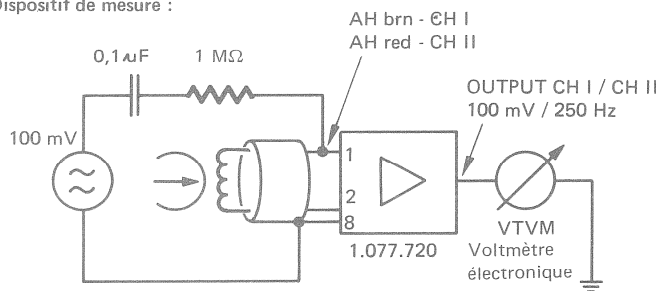

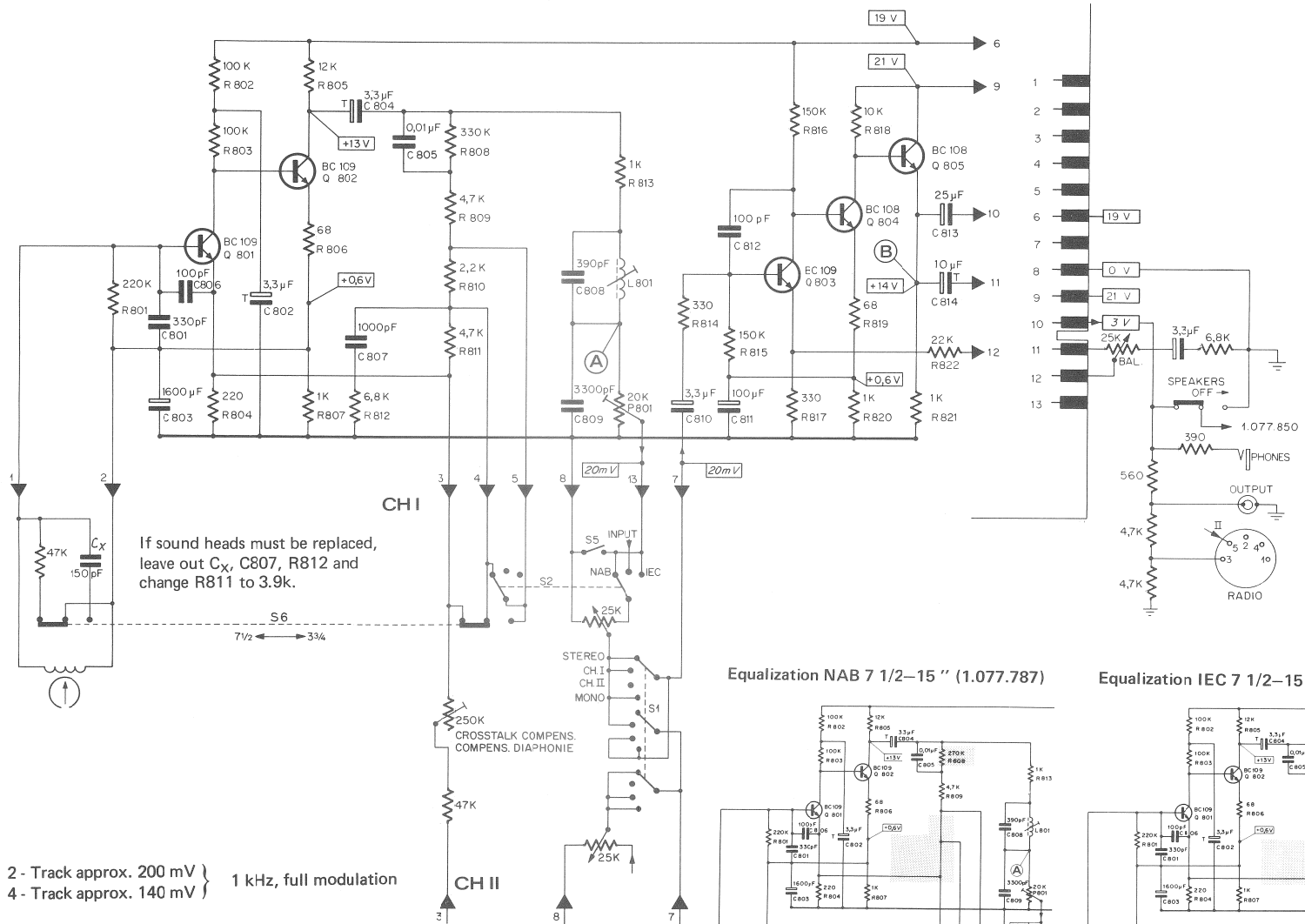

Test points :

- (A) 2 - Track approx. 200 mV } 1 kHz, full modulation
- 4 - Track approx. 140 mV }
- (B) Balance, Control Range ± 7 dB

Points de mesure :

- (A) 2 pistes env. 200 mV } à 1 kHz et modulation maximum
- 4 pistes env. 140 mV }
- (B) plage de réglage de la balance ± 7 dB

Equalization NAB 7 1/2-15 '' (1.077.787)

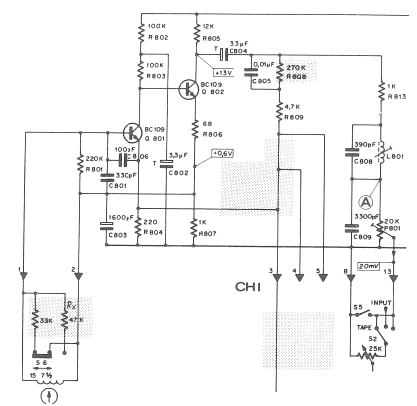

Equalization IEC 7 1/2-15 '' (1.077.785)

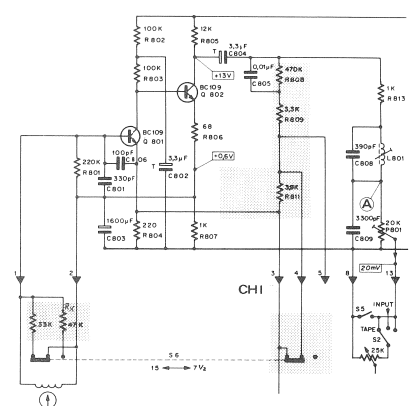

Playback Amplifier
Amplificateur de lecture 1.077.720

Unspecified carbon film resistors :
 1/8W - 5 %
 Résistance à couche sans spécification :
 1/8 W - 5 %

** Commercial types
 ** Type d'usage courant

Identification Position	Part Name Désignation	Type / Remarks Type / Remarques	Specifications Spécifications	Order Number Numéro de commande
	Playback Amplifier Amplificateur de reproduction	Board assembled plaquette complète		1.077.720
Q 801 Q 802	Transistor	BC 109 C, BC 149 C		**
Q 803	Transistor	BC 109 B, BC 149 B		**
Q 804 Q 805	Transistor	BC 108 B, BC 148 B		**
R 801	Resistor résistance	carbon film à couche	220 k	**
R 802 R 803	Resistor résistance	carbon film à couche	100 k	**
R 804	Resistor résistance	carbon film à couche	220	**
R 805	Resistor résistance	carbon film à couche	12 k	**
R 806	Resistor résistance	carbon film à couche	68	**
R 807	Resistor résistance	carbon film à couche	1 k	**
R 808	Resistor résistance	carbon film à couche	330 k	**
R 809 R 811	Resistor résistance	carbon film à couche	4.7 k	**
R 810	Resistor résistance	carbon film à couche	2.2 k	**
R 813	Resistor résistance	carbon film à couche	1 k	**
R 814	Resistor résistance	carbon film à couche	330	**
R 815	Resistor résistance	carbon film à couche	150 k	**
R 816	Resistor résistance	carbon film à couche	150 k	**
R 817	Resistor résistance	carbon film à couche	330	**
R 818	Resistor résistance	carbon film à couche	10 k	**
R 819	Resistor résistance	carbon film à couche	68	**
R 820	Resistor résistance	carbon film à couche	1 k	**
R 821	Resistor résistance	carbon film à couche	1 k	**
R 822	Resistor résistance	carbon film à couche	22 k	**
P 801	Trim-Potentiometer pot. ajustable	Ruwido P 76 K	20 k - 20 % - 0.15 W	**
C 801	Capacitor condensateur	Polystyrol au polystyrol	330 pF - 5 % - 160 V	**
C 802	Capacitor condensateur	tantalum au tantale	3.3 µF - 15 V	**
C 803	Capacitor condensateur	electrolytic électrolytique	1600 µF - 3 V	**
C 804	Capacitor condensateur	electrolytic électrolytique	3.3 µF - 35 V	**
C 805	Capacitor condensateur	polyester au polyester	.01 µF - 5 % - 160 V	**
C 806 C 812	Capacitor condensateur	polystyrene au polystyrène	100 pF - 10 % - 160 V	**
C 807	Capacitor condensateur	polyester au polyester	1000 pF - 10 % - 400 V	**
C 808	Capacitor condensateur	polystyrene au polystyrène	390 pF - 5 % - 160 V	**
C 809	Capacitor condensateur	polyester au polyester	3300 pF - 10 % - 400 V	**
C 810	Capacitor condensateur	tantalum au tantale	3.3 µF - 15 V	**
C 811	Capacitor condensateur	electrolytic électrolytique	100 µF - 3 V	**
C 813	Capacitor condensateur	electrolytic électrolytique	25 µF - 25 V	**
C 814	Capacitor condensateur	tantalum au tantale	10 µF - 15 V	**
L 801	Choke Coil bobine	assembled complète		1.077.750

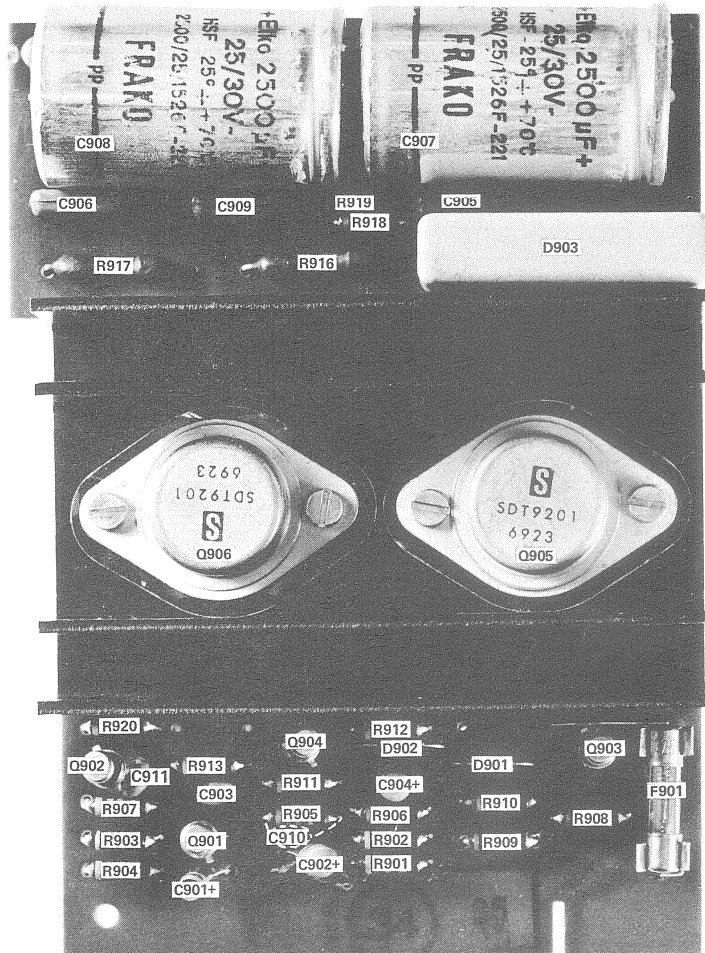

Loudspeaker Amplifier 1.077. 850
 Amplificateur de haut-parleur

Loudspeaker Amplifier with Final Transistors BD 121
Amplificateur de haut-parleur avec transistors de puissance BD 121

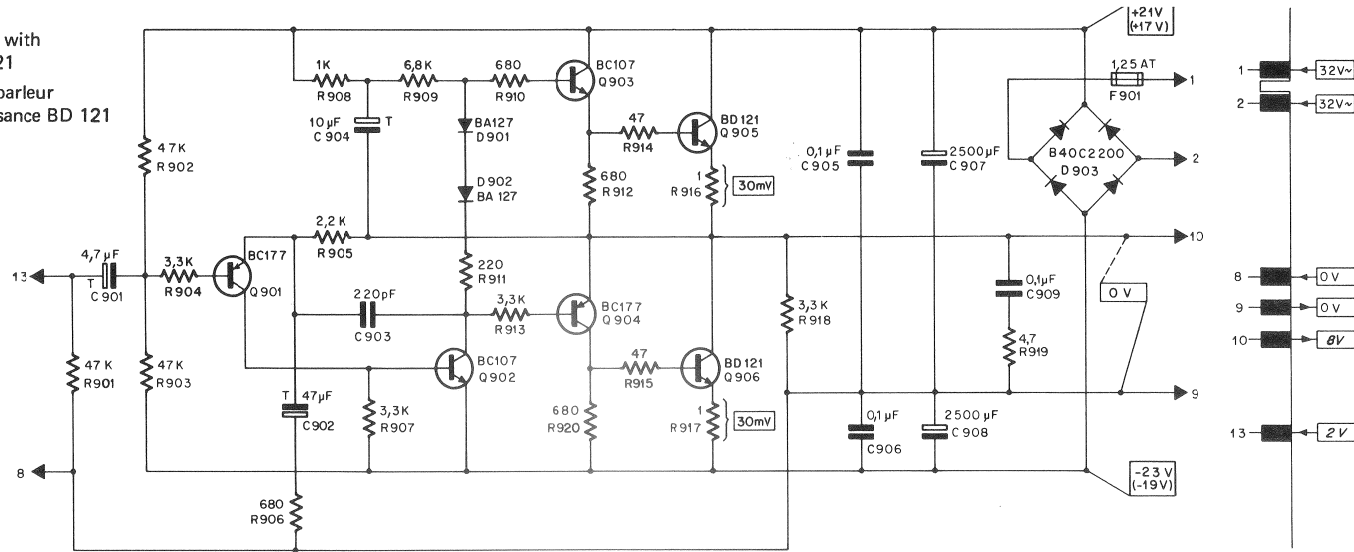

Loudspeaker Amplifier with Final Transistors SDT 9201
Amplificateur de haut-parleur avec transistors de puissance SDT 9201

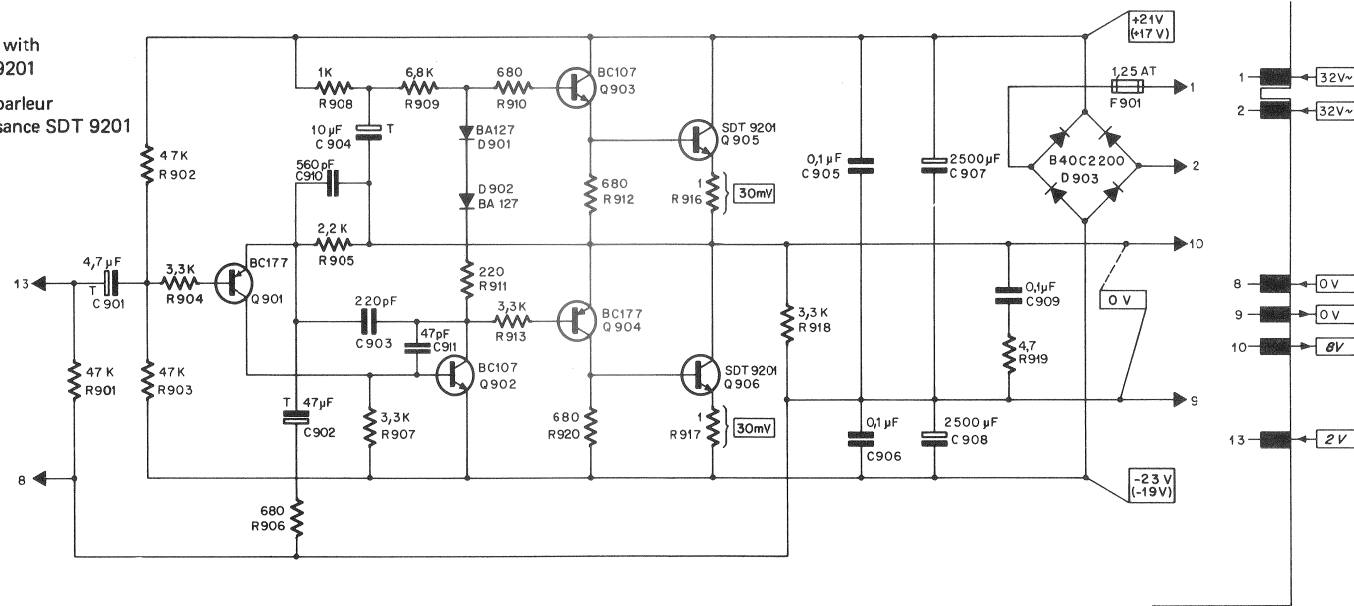

Loudspeaker Amplifier
Amplificateur de haut-parleur

1.077.850

Unspecified carbon film resistors :
 1/8 W - 5 %
 Résistance à couche sans spécification :
 1/8 W - 5%

** Commercial types
 ** Type d'usage courant

Identification Position	Part Name Désignation .	Type / Remarks Type / Remarques	Specifications Spécifications	Order Number Numéro de command
	Loudspeaker Amplifier Amplificateur de haut-parleur	Board assembled plaquette complète		1.077.850
Q 901	Transistor	BC 177 A, BC 157 A		**
Q 901	Transistor	BC 107 A/B, BC 147 A/B		**
Q 903	Transistor	BC 107 A/B		**
Q 904	Transistor	BC 177 A		**
Q 905 Q 906	Transistor	BD 121 (Philips)		**
D 901 D 902	Si-Diode diode au silicium	BA 127	50 V - 100 mA	**
D 903	Si-Rectifier redresseur au silicium	B 40 C 2200		**
R 901 - R 903	Resistor résistance	carbon film à couche	47 k	**
R 904	Resistor résistance	carbon film à couche	3.3 k	**
R 905	Resistor résistance	carbon film à couche	2.2 k	**
R 906	Resistor résistance	carbon film à couche	680	**
R 907	Resistor résistance	carbon film à couche	3,3 k	**
R 908	Resistor résistance	carbon film à couche	1 k	**
R 909	Resistor résistance	carbon film à couche	6.8 k	**
R 910	Resistor résistance	carbon film à couche	680	**
R 911	Resistor résistance	carbon film à couche	220	**
R 912 R 920	Resistor résistance	carbon film à couche	680	**
R 913	Resistor résistance	carbon film à couche	3.3 k	**
R 914 R 915	Resistor résistance	carbon film à couche	47	**
R 916 R 917	Resistor résistance	wire bobinée	1 - 10 % - 1 W	**
R 918	Resistor résistance	carbon film à couche	3.3 k	**
R 919	Resistor résistance	carbon film à couche	4.7 k	**
C 901	Capacitor condensateur	tantalum au tantale	4.7 μ F - 10 V	**
C 902	Capacitor condensateur	tantalum au tantale	47 μ F - 3 V	**
C 903	Capacitor condensateur	ceramic céramique	220 pF - 10 % - 50 V	**
C 904	Capacitor condensateur	tantalum au tantale	10 μ F - 15 V	**
C 905 C 906	Capacitor condensateur	polyester au polyester	0.1 μ F - 20 % - 100 V	**
C 907 C 908	Capacitor condensateur	electrolytic électrolytique	2500 μ F - 25 V	**
C 909	Capacitor condensateur	polyester au polyester	.1 μ F - 20 % - 100 V	**
F 901	Fuse fusible	5 x 20 slo-blo retardé	1.25 A	**
	Additional for amplifier with SDT 9201 final transistors			
	Variante avec transistors de puissance SDT 9201			
Q 905 Q 906	Transistor	SDT 9201		**
C 910	Capacitor condensateur	ceramic céramique	560 pF - 10 % - 50 V	**
C 911	Capacitor condensateur	ceramic céramique	47 pF - 10 % - 50 V	**
R 914	Resistor résistance	bridged court-circuitée		
R 915	Resistor résistance	bridged court-circuitée		

	SLOW	FAST	
(A)			
(B)			
(C)			
(D)			
(E)			
(F)			
(G)			
(H)			
	1.077.724	$T=1250\mu s$	$U = 1V_{pp}$
	1.077.729	$T=2500\mu s$	$U = 2.5V_{pp}$

Valid if IC201 = SN76131N

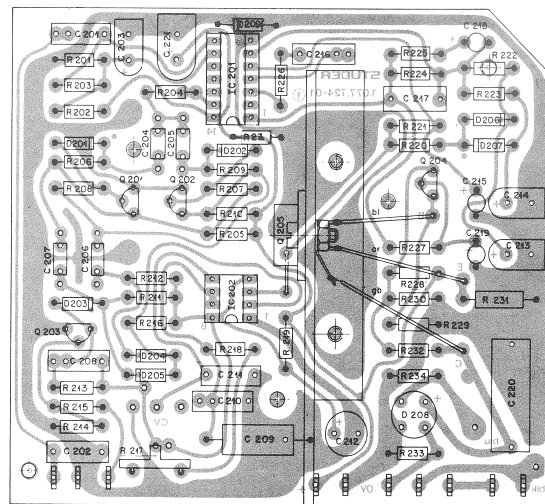
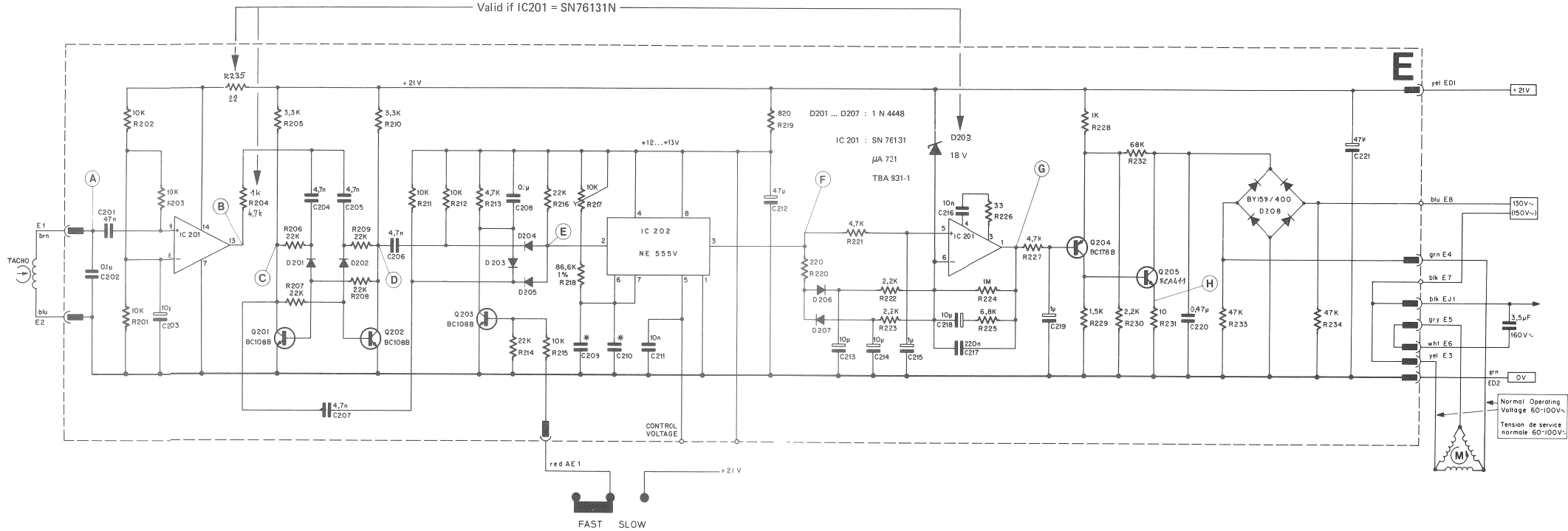

VERSION	1.077.724	1.077.729
SPEED	3.3/4 - 71/2" 71/2 - 15"	1.7/8 - 3.3/4"
* C209	1.6 n	2.4 n
* C210	4.7 n	10 n



Speed Control
Drehzahlregelung
Régulation de vitesse

1.077.724/729

Pos.	Bauteil No.	Bezeichnung	Stk.	Bemerkung
C 201	59.31.4473	C 47N 20% 160V MPETP		
202	59.31.4104	C .1U, 20% 160V MPETP		
203	59.22.8100	C 10U; 100% 63V EL		
204	59.32.3472	C 4,7N, 100% 40V KER		
205	59.32.3472	C 4,7N, 100% 40V KER		
206	59.32.3472	C 4,7N, 100% 40V KER		
207	59.32.3472	C 4,7N 100% 40V KER		
208	59.31.4104	C .1U 20% 160V MPETP		
② 209	59.12.8162	C 1.6N, 1% 125V PS		
210	59.11.4472	C 4,7N 2,5% 160V PC		
211	59.31.4103	C 10N, 20% 160V PETP		
212	59.22.4470	C 47U, 100% 16V EL		
213	59.22.8100	C 10U 100% 63V EL		
214	59.22.8100	C 10U, 100% 63V EL		
215	59.30.6109	C 1U, 50% 35V TA		
216	59.31.4103	C 10N, 20% 160V PETP		
217	59.31.1224	C .22U, 20% 100V MPETP		
218	59.30.4100	C 10U, 50% 16V TA		
219	59.30.6109	C 1U, 50% 16V TA		
220	59.99.0450	C .47U, 20% 150V MP		
221	59.22.6470	C 47U, 50% 40V EL		
D 201	50.04.0125	D 1N4448	SI	
202	50.04.0125	D		
203	50.04.0125	D		
204	50.04.0125	D		
205	50.04.0125	D		
206	50.04.0125	D		
207	50.04.0125	D		
208	70.01.0223	D BY 159 / 400	SI	
③ 209	50.04.1122	D 18V 5% 4W	SI	
④ IC 201	50.05.0237	IC SN 76 131W	LIN	
202	50.05.0158	IC NE 555 V	TIMER	
Aenderungen	⑥ 16.6.77 Rom ⑦	③ 24.6.76 Rom	④ 6.12.76 Rom.	⑤ 15.4.77 Rom.
STUDER REGENSDORF ZÜRICH	Positionsliste		Erstellt: 27.5.74 Rom.	
	Regelprint 9,5 / 19		Geprüft: Rom.	
			Blatt: 1 Blätter: 3	
Kopie für:		Ersatz für:		1.077.724
		Ersetzt durch:		

Pos.	Bauteil No.	Bezeichnung	Stk.	Bemerkung
Q 201	50.03.0438	Q BC 108 B aequiv. NPN		
202	50.03.0438	Q		
203	50.03.0438	Q		
204	50.03.0318	Q BC 178 B aequiv. PNP		
① 205	50.03.0477	Q RCA 411 NPN		
R 201	57.41.4103	R 10 K, 5%, .25W, CSCH		
202	57.41.4103	R 10 K,		
203	57.41.4103	10 K,		
⑤ 204	57.41.4102	1 K,		
205	57.41.4332	3,3 K,		
206	57.41.4223	22 K,		
207	57.41.4223	22 K,		
208	57.41.4223	22 K,		
209	57.41.4223	22 K,		
210	57.41.4332	3,3 K,		
211	57.41.4103	10 K,		
212	57.41.4103	10 K,		
213	57.41.4472	4,7 K,		
214	57.41.4223	22 K,		
215	57.41.4103	10 K,		
216	57.41.4223	22 K,		
217	58.99.0126	R 10 K, 20%, T-Schicht PCSCH		
218	57.99.0179	R 86,6 K, 1% 50 PPM MF		
219	57.41.4821	R 820 , 5% .25W CSCH		
220	57.41.4221	220 ,		
221	57.41.4472	4,7 K,		
222	57.41.4222	2,2 K,		
223	57.41.4222	2,2 K,		
224	57.41.4105	1 M,		
225	57.41.4682	6,8 K,		
226	57.41.4330	33 ,		
Aenderungen ⑥ 16.6.77 Rom. ⑦ ③ 24.6.76 Rom. ④ ⑤ 57.41.4103				
STUDER		Positionsliste		Erstellt: 27.5.74 Rom.
REGENSDORF		ZURICH		Geprüft: Rom
Kopie für:		Ersatz für:		Blatt: 2 Blätter: 3
		Ersetzt durch:		1.077.724

Pos.	Bauteil No.	Bezeichnung	Stk.	Bemerkung
R 227	57.41.4472	R 4,7 K, 5% .25W CSCH		
228	57.41.4102	1 K,		
229	57.41.4152	1,5 K,		
230	57.41.4222	2,2 K,		
231	57.43.4100	10 , .5W		
232	57.41.4683	68 K, .25W		
233	57.41.4473	47 K,		
234	57.41.4473	47 K,		
⑥ 235	57.41.4220	22 ,		
Aenderungen ⑥ 16.6.77 Rom. ⑦ ③ 24.6.76 Rom. ④ 6.12.76 Rom. ⑤ 15.4.77 Rom.				
STUDER		Positionsliste		Erstellt: 27.5.74 Rom.
REGENSDORF		ZURICH		Geprüft: Rom
Kopie für:		Ersatz für:		Blatt: 3 Blätter: 3
		Ersetzt durch:		1.077.724

11. REPLACEMENT PARTS LIST

The replacement parts list is divided into following columns :

INDEX The index number matches the one on the illustration
Take note of the letters referring to said illustration.

QUANTITY (QTY) Indicates the number of parts in the assembly.

PART NAME The short designation, obligatory, is to be included
when writing orders.

ORDER NUMBER Use these part numbers only on all orders.

Note :

**All Orders Must be with Order Number and
PART NAME.**

In - production changes are noted on separate sheets (e. g. PL 6a).
Red index numbers designate these separate sheets.

Check the separate sheets when ordering, please.

INDEX	QTY	PART NAME	ORDER NUMBER
	1	Carrying case, assembled	1.077.831
	1	Cover, case, assembled	1.077.834
	1	Side, left, with loudspeaker	1.077.832
	1	Side, right, with loudspeaker	1.077.833
	4	Loudspeakers	71. 01.0102
		Loudspeakers From No 277664	71. 01.0150
		Loudspeakers From No 279969	71. 01.0151
	1	Handle, carrying, assembled	1.077.805
	1	Fastener, handle	1.077.800 - 08
	1	Cover, voltage selector, with frame	1.077.806
	1	Cover, plastic " connections "	1.077.800 - 01
	1	Cover, plastic " air access "	1.077.800 - 06
	4	Support, rubber, case fastening	1.077.800 - 20
		Lock	
	1	Case lock	33. 01.0104
	1	Key	33. 01.0106
		Fastenings, carrying case	
	4	Screw, sheet metal	20. 21.7311
	4	Washer	23. 01.3043
	4	Foot, case	1.077.831 - 02
	1	Cabinet, walnut, assembled	1.077.800
		Feet, for vertical operation	
	2	Rail, plastic, less feet	1.077.800 - 03
	4	Foot, rubber	1.077.800 - 04
		Fastenings, walnut cabinet	
	4	Screw, sheet metal	20. 21.7310
	4	Washer	1.010.007 - 23
	1	Disconnecter, protectiv	1.077.845
	1	Installation unit, sheet metal incl. fasteners	1.077.840
	3	Fastener	1.040.255
	4	Screw, sheet metal	20. 21.7308

INDEX	QTY	PART NAME	ORDER NUMBER
A		Chassis	
01	1	Chassis, tape drive	1.077.100 - 01
02	1	Frame, left	1.077.100 - 02
03	1	Frame, right	1.077.100 - 03
04	1	Chassis, switch board	1.077.430 - 01
05	1	Panel, shield	1.077.114
06	1	Rail, terminal	1.077.550
07	16	Snapnut	22. 16.2021
08	4	Screw, sheet metal	20. 21.7312
09	4	Washer	1.010.008 - 23
10	8	Screw, sheet metal	20. 21.7308
11	2	Bracket, double angle	1.077.100 - 18
		Plastic Cover, Knobs	
1		Cover, drive	1.077.600
		Cover, drive, for MK II, III, IV	1.077.650
		Panel, front, VU - port bridged	1.077.604
		Panel, front, for MK III	1.077.652
		Panel, front, for MK IV	1.077.670
1		Lid, assembled	1.077.609
		Lid, for MK III	1.077.660
		Lid, for MK IV	1.077.661
2		Spring, lid	1.077.603 - 01
1		Cover, head	1.077.665
4		Knob, rotary, gray MK III	1.077.632
		Knob, rotary, gray MK IV	1.077.631
1		Knob, rotary, balance	1.077.633
4		Skirt, knob, clear	1.077.625 - 01
		Skirt, knob, for MK III	1.077.626 - 01
		Skirt, knob, Tape - Input	1.077.644
		Skirt, knob, Stereo - I - II - Mono	1.077.645
		Skirt, knob, NAB -Input - IEC	1.077.646
		Skirt, knob, CH 1	1.077.647
		Skirt, knob, CH 2	1.077.648
1		Knob, switch, POWER, for MK III	1.077.636
		Knob, switch, POWER, for MK IV	1.077.637

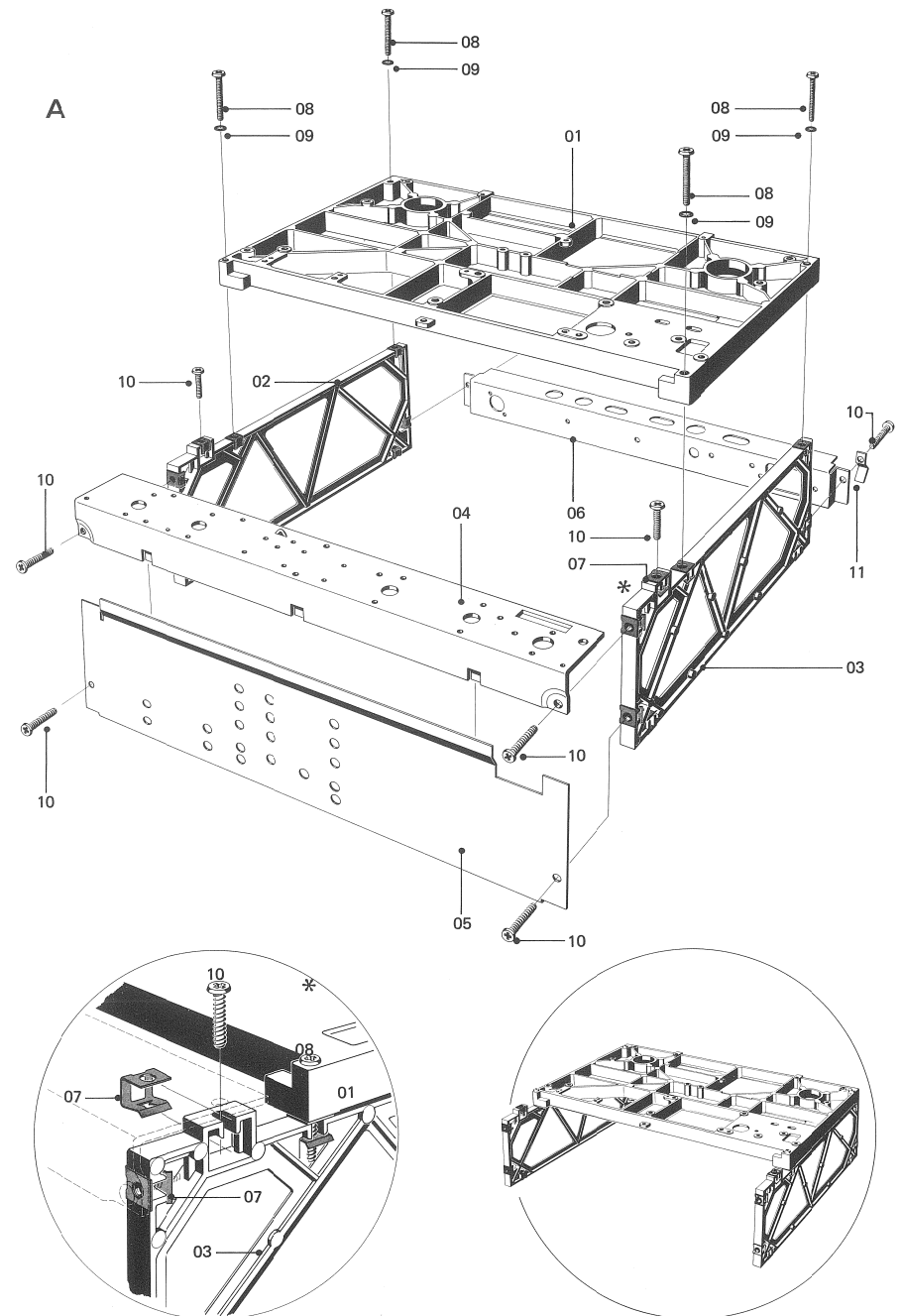

INDEX	QTY	PART NAME	ORDER NUMBER
B		Push Button, Unit	
01	1	Bearing strip, push button (incl. 5 bars)	
02	5	Bracket, plastic (clear)	1.077.490 - 04
03	4	Push button, gray	1.077.490 - 05
04	1	Push button, red	1.077.490 - 06
05	1	Shield plate	1.077.100 - 14
06	1	Spring, tension, tape lift	1.077.100 - 11
07	1	Bar switch, " Speakers Off " " Reel Motors Off ", assembled	1.077.355 - 03
		Socket	
08	3	Socket, Jack, assembled	1.077.500
09	2	Shield plate	1.077.430 - 06
		VU - Meter	
10	2	VU-Meter	1.077.470 - 03
		VU-Meter for MK III	1.077.470 - 04
11	1	Bracket	1.077.485
12	1	Support	1.077.470 - 01
13	2	Push button, red	1.077.475 - 01
14	2	Switch, slide,	1.077.475 - 03
		Lamp socket for MK III	1.077.471
15	7	Socket, plug, assembled	1.077.115
16	7	Sleeve, spring	1.077.100 - 21
		Switch, Board	
17	1	Housing, switch (Before / after tape switch)	1.011.300 - 01
17	1	Housing, switch (Playback mode switch)	1.011.400 - 01
17	2	Housing, switch (Input selector)	1.011.500 - 01
18	4	Rotor, incl. hollow shaft	1.011.180
19	4	Spring, compression (indexing)	1.011.200 - 04
20	4	Ball (indexing)	41. 01.0130
21	13	Contact	1.010.001 - 55

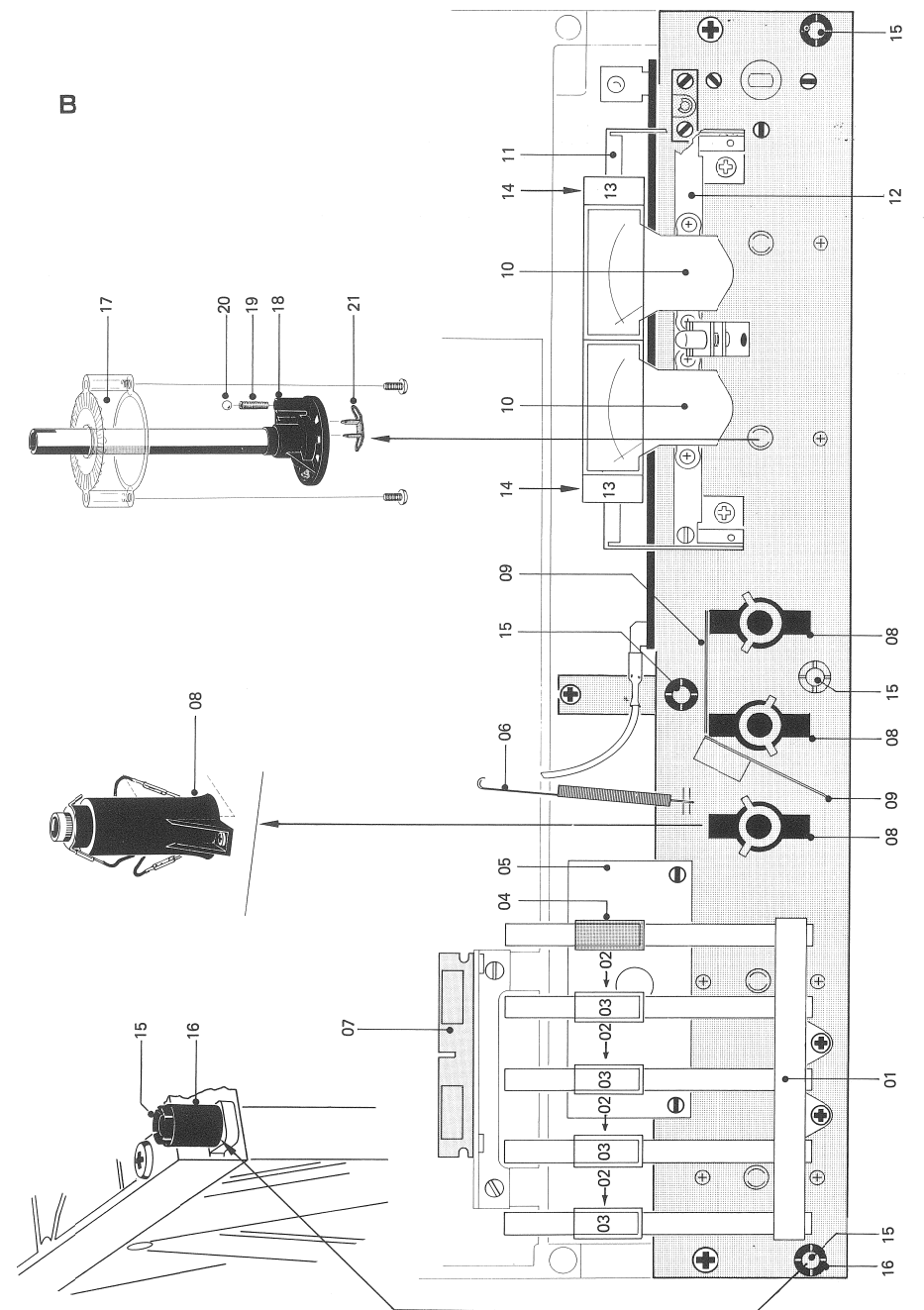

INDEX	QTY	PART NAME	ORDER NUMBER
C		Switch, Power	
01	1	Switch, power, assembled	1.077.440
02	1	Micro-switch (tape tension)	55. 01.0124
03	2	Rivet, tubular	28. 21.1415
04	2	Micro-switch (line)	55. 01.0124
05	4	Bushing, insulation	1.077.440 - 08
06	1	Foil, insulation	1.077.440 - 05
07	2	Spring, flat	1.077.440 - 03
08	1	Ball	41. 01.0160
09	2	Bearing, plastic	1.077.450 - 04
10	4	Clip, retaining Ø 4 mm	24. 16.3040
11	1	Cam, switch (white plastic) with bushing	1.077.450
12	1	Lever	1.077.460
13	1	Bearing	1.077.455
14	2	Ring, retaining Ø 2.3 mm	24. 16.3023
15	1	Washer, tap, hard paper	1.077.440 - 04
16	1	Stop (turn limiting)	1.077.445 - 02
17	1	Bar	1.077.430 - 04
18	1	Link, connecting	1.077.430 - 03
		Rail, Connector	
01	1	Rail, connector, with power cable and remote control cabling	1.077.550
02	1	Enclosure, protective disconnecter	1.077.555
03	1	Socket, instrument	54. 04.0103
04	3	Socket, twin, Cinch	54. 02.0293
05	2	Socket, loudspeaker	54. 02.0301
06	1	Socket, 5 - pole RADIO	54. 02.0310
07	1	Socket, 10 - pole, REMOTE CONTROL	54. 02.0315
08	1	Plug, dummy, remote control, assembled	1.077.570

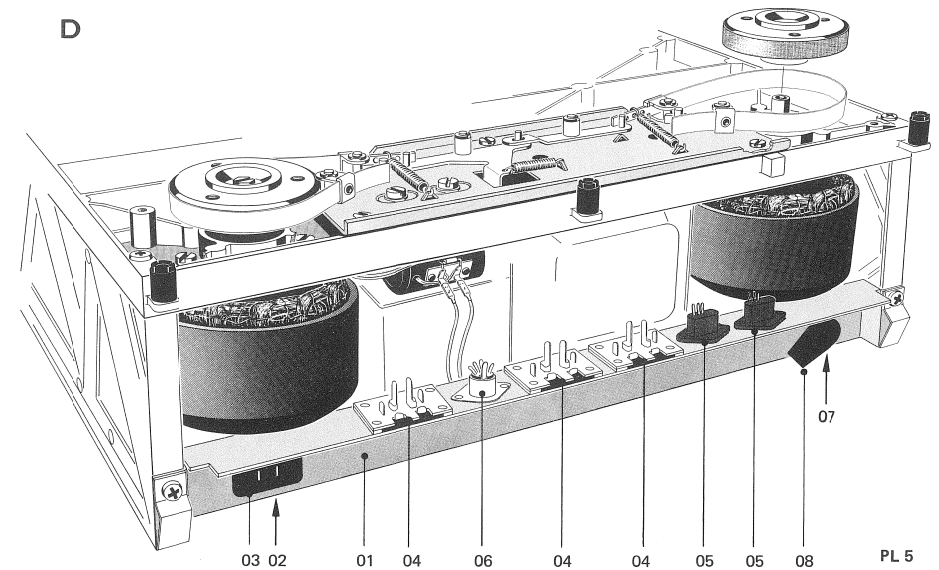
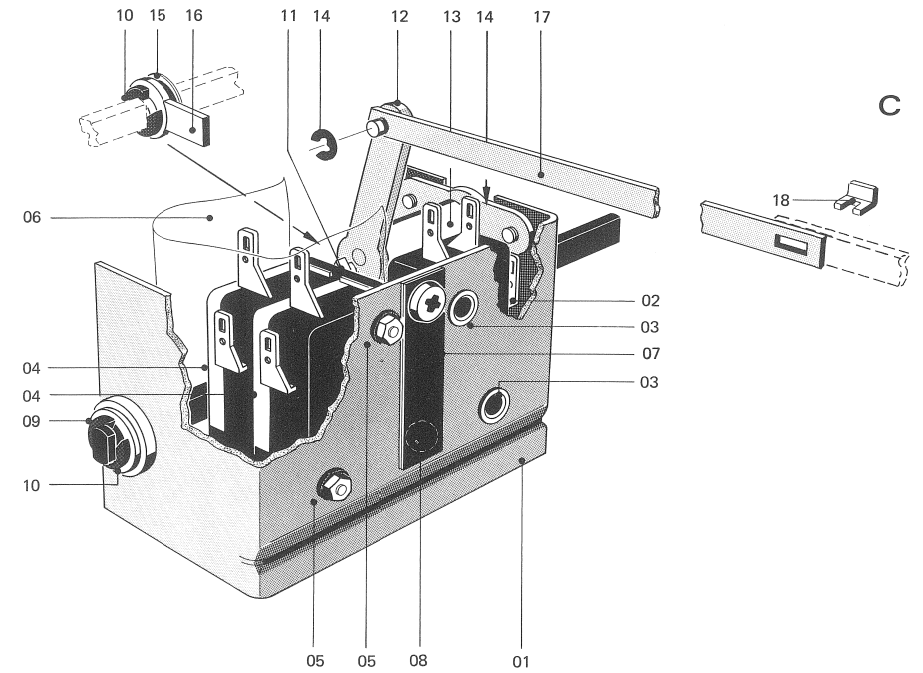

INDEX	QTY	PART NAME	ORDER NUMBER
E		Drive, Tape & Headblock	
01	1	Chassis, cast, tape drive, with pressure lever sintered bearings	
02	4	Cup, tape guide	1.736.222 - 04
03	2	Collar, tape guide	1.736.222 - 05
04	2	Bushing, threaded	1.077.120 - 02
05	4	Screw M 4 x8	21. 01.0455
06	1	Post, tape guide	1.077.120 - 01
07	2	Screw M 3 x 8	21. 01.0355
08	1	Guide, tape, assembled	1.077.145
09	1	Bracket, assembly	1.077.150
10	1	Spring, compression	1.077.145 - 03
11	2	Disc , guide	1.077.145 - 01
12	1	Sleeve, spacer	1.077.145 - 02
13	1	Nut, hex M 3	22. 01.5030
14	1	Lever, tape lift, assembled	1.077.175
15	1	Screw , spec	1.077.120 - 03
16	1	Washer	1.077.120 - 04
17	1	Bracket	1.077.133
18	1	Socket, lamp	53. 04.0102
19	1	Lamp (24 V, 30 mA),	51. 02.0140
20	1	Resistor, photoelectric (end-of-tape switch)	1.077.135
21	1	Base plate, assembled (2 - hole head-fastening)	
22	1	Base plate, assembled (1 - hole head-fastening)	1.077.157
23	2	Housing, shield, ext (2 - hole head-fastening)	
24	2	Housing, shield, ext (1 - hole head-fastening)	1.077.155 - 05
25	2	Housing, shield, int (2 - hole head-fastening)	
26	2	Housing, shield, int (1 - hole head-fastening)	1.077.155 - 06
	4	Plastic pin	1.077.155 - 07
27	1	Lid, shield, playback head, assembled	1.077.165
28	1	Head, playback, 2 - track, (2 - hole head-fastening)	1.116.026
	1	Head, playback, 4 - track, (2 - hole head-fastening)	1.116.046
29	1	Head, playback, 2 - track, (1 - hole head-fastening)	1.116.027
	1	Head, playback, 4 - track, (1 - hole head-fastening)	1.116.047
30	1	Head, record, 2 - track, (2 - hole head-fastening)	1.116.021
	1	Head, record, 4 - track, (2 - hole head-fastening)	1.116.041
31	1	Head, record, 2 - track, (1 - hole head-fastening)	1.116.022
	1	Head, record, 4 - track, (1 - hole head-fastening)	1.116.042
32	1	Head, erase, 2 - track	89. 01.0301
	1	Head, erase, 4 - track	89. 01.0302
33	1	Shim, 4 - track head	1.077.131 - 01
	1	0.1 mm shim, brass for elevation adjustment of erase head	1.010.006 - 23

INDEX	QTY	PART NAME	ORDER NUMBER
E			
34	1	Screw, spec (erase head fastening)	1.077.130 - 02
35	4	Screw, spec (Rec / Play head fastening, 2 - hole)	21. 99.0114
36	2	Screw, spec (Rec / Play head fastening, 1 - hole)	21. 99.0118
37	4/2	Washer, head fastening	23. 01.1032
38	4/2	Washer, securing, head fastening	24. 16.1030
39	2	Screw M 2 x 3, screen lid	21. 01.0201
40	7	Screw M 3 x 6	21. 01.0354
41	4	Setscrew M 3 x 6	21. 18.6354
42	1	Lever, pressure,assembled with pressure roller	1.077.305
43	1	Pressure roller	1.077.312
44	1	Shaft	1.077.305 - 05
45	2	Washer, teflon	1.736.200 - 04
46	1	Snap	1.736.200 - 03
47	1	Lever, pressure, stripped	1.077.305 - 02
48	1	Lever	1.077.305 - 01
49	2	Setscrew, spec	1.077.305 - 06
50	1	Screw, hex head, M 4 x 14	1.077.305 - 07
51	1	Spring, compression	1.077.305 - 04
52	2	Washer, hard paper	
53	1	Shaft	1.077.305 - 03
54	1	Lever	1.077.320
55	1	Link	1.077.100 - 10
56	2	Clip Ø 3.2 mm	24. 16.3032
57	1	Lever	1.077.325
58	2	Setscrew, spec	1.077.325 - 03
59	1	Clevis	1.077.330 - 01
60	1	Screw M 3 x 6	21. 01.0354
61	1	Washer, lock	24. 16.1030
62	1	Plunger	1.077.330
63	1	Solenoid, assembled	1.014.700*
64	1	Nut, hex M 4	22. 01.8040
65	1	Washer	23. 01.3043
66	1	Lever, trip, with knob	1.077.340
67	1	Knob, trip lever	1.736.790 - 02
68	1	Spring, helical	1.077.100 - 08
69	2	Bolt	1.077.100 - 07
70	2	Bolt, threaded	1.736.375 - 01
71	1	Washer	1.736.502 - 04

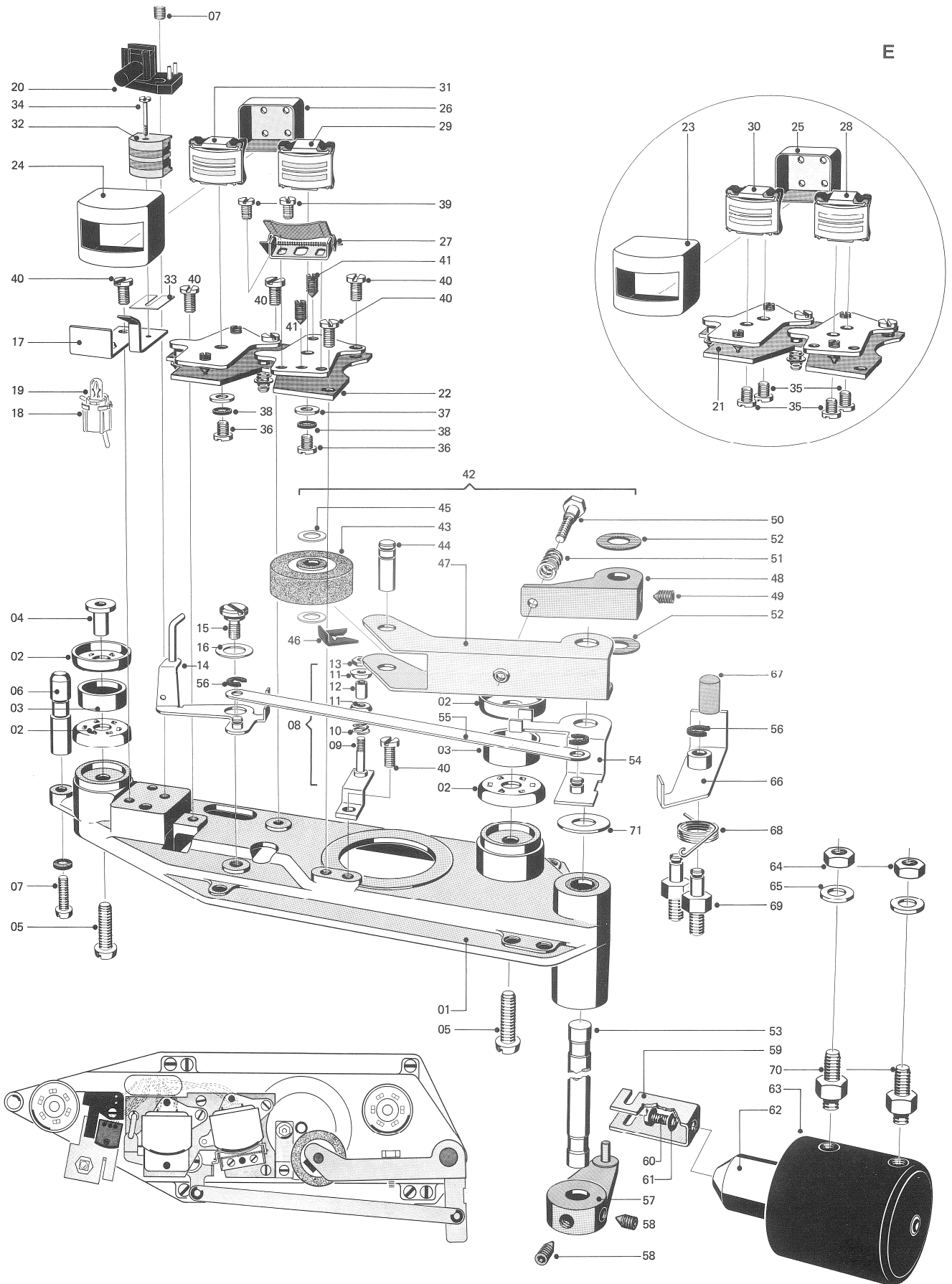

INDEX	QTY	PART NAME	ORDER NUMBER
E 1		Feeler	
01	1	Chassis, cast, tape drive, with pressure lever sintered bearings	1.077.126
02	2	Sleeve, threaded	1.077.121 - 01
03	2	Nut, hex	22.99.0103
04	4	Cap, guiding	1.077.121 - 02
05	2	Washer	1.077.121 - 09
05	2	Washer	1.077.121 - 10
06	1	Bearing, ball	41.99.0102
07	2	Screw, shoulder	1.077.121 - 05
08	1	Ring, plain	1.077.121 - 04
09	1	Stud, threaded	1.077.121 - 06
10	1	Feeler, assembled	1.077.185
11	1	Bolt, guiding	
12	1	Screw, machine, slotted head M 3 x 6	21.01.0354
13	1	Spring, tension	1.077.121 - 08
14	1	Washer	1.077.121 - 07
15	1	Bracket (angle), with spring	1.077.180
16	1	Nut, hex	22.01.8040
17	1	Plunger, complet	1.077.330
		From S 37751 + G 43228	1.077.331
18	1	Screw, collared	1.077.331 - 02
19	1	Clevis	1.077.331 - 01
20	1	Screw, hex, head dog point	1.077.305 - 08
53	1	Shaft with hole	1.077.305 - 03

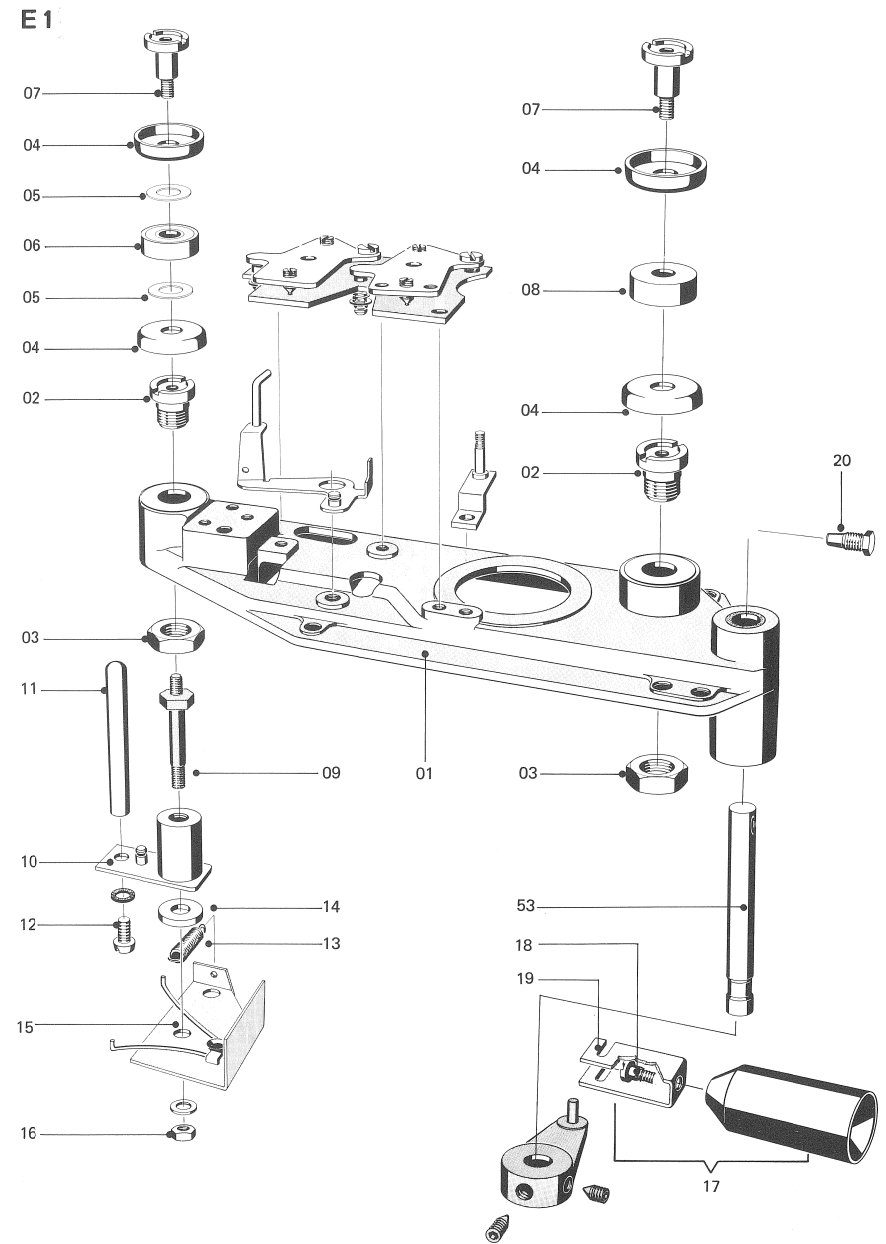

INDEX	QTY	PART NAME	ORDER NUMBER
F		Brake System	
01	1	Chassis, brake	
02	3	Screw M 3 x 6	21. 01.0354
03	3	Washer, lock	24. 99.0105
04	1	Lever, brake	1.077.411
05	1	Lever, brake	1.077.415
06	1	Spring, helical	1.062.210 - 06
07	2	Band, brake	1.077.420
08	2	Spring, helical, brake	1.077.100 - 13
09	6	Clip, retaining Ø 3.2 mm	24. 16.3032
10	1	Solenoid (without plunger)	1.014.750
11	1	Plunger, with collar screw & retainer	1.014.708
12	2	Screw M 4 x 5 (length 5 mm max !)	21. 01.0453
13	2	Washer	24. 99.0106
14	2	Motor, reel (see G - motor, reel)	1.077.280
15	2	Spacer	1.077.100 - 06
16	2	Washer, height adjustment (according to need)	1.736.502 - 04
17	2	Washer, star	24. 16.6080
18	2	Drum, brake, with lining & star washer	1.077.560
		Lining, brake (by the meter)	89. 01.0155
19	2	Washer	23. 01.3043
20	2	Spring, belleville	37. 01.0103
21	2	Screw, hex head M 4 x 8	21. 01.4455
22	2	Turntable, metal	1.077.564
22a			
23	6	Screw M 3 x 8, Ni-plated	21. 02.0355
24	2	Shaft section, 3 - prong	1.077.568 - 03
25	2	Spring, compression	1.736.794 - 03
26	2	Screw, shoulder	1.077.568 - 02
27	8	Screw M 4 x 8	21. 01.0455
28	1	Counter	1.077.100 - 09
29	1	O - Ring	31. 99.0106
30	1	Bolt, threaded	1.077.100 - 19
31	1	Cap, rubber	1.077.100 - 20
32	1	Screw M 3 x 8	21. 01.0355
33	2	Washer, flat	23. 01.2032
34	2	Washer, lock, helical	24. 99.0107

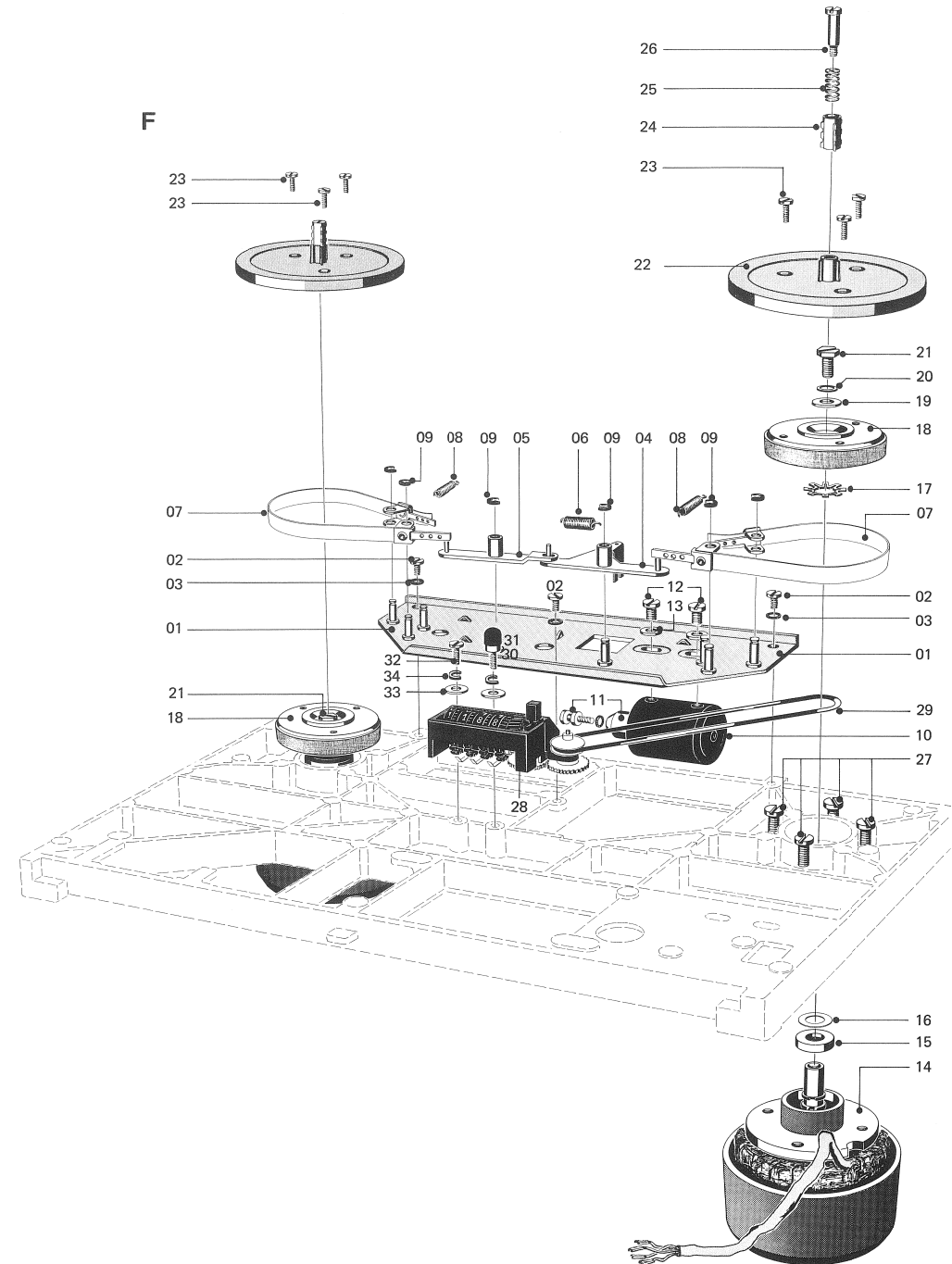

INDEX	QTY	PART NAME	ORDER NUMBER
F1		Modified Brake System	
01	1	Chassis	1.077.406
02	2	Band	1.077.421
03	2	Drum, complete with lining and star washer	1.077.561
		Drum, complete with lining and star washer from 111813	1.077.562

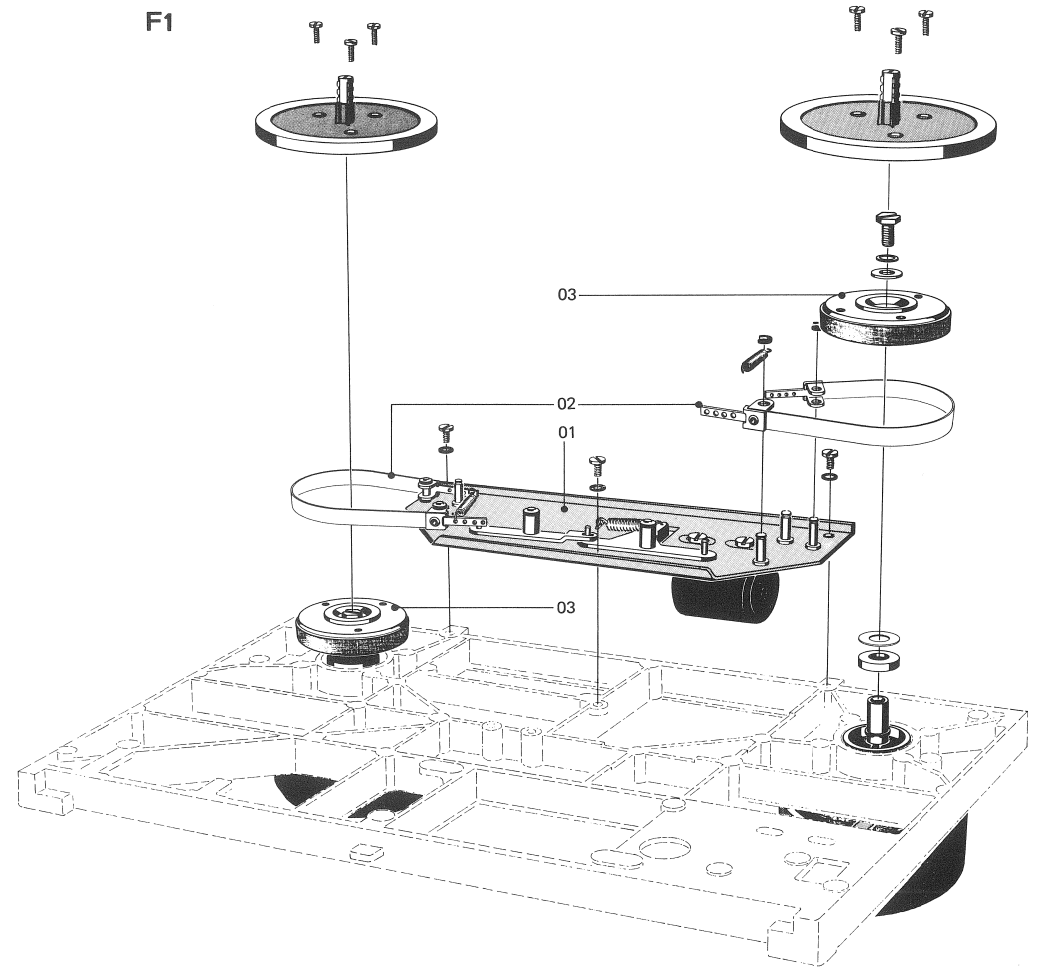

INDEX	QTY	PART NAME	ORDER NUMBER
G		Motor, Reel	
		In case of a defective stator, rotor, or shaft, exchange motor. (See also F - Brake System).	
	1	Motor, reel, assembled	
01	1	Clip, spring	24. 99.0111
02	1	Ring, retaining, external Ø8 mm	24. 16.5080
03	2	Bearing, ball EL8 608	41. 99.0105
04	2	Ring, retaining, (internal Ø22 mm)	24. 16.4220
05	4 - 6	Spring, belleville put in only enough springs till axial play is taken up	37. 02.0103

G

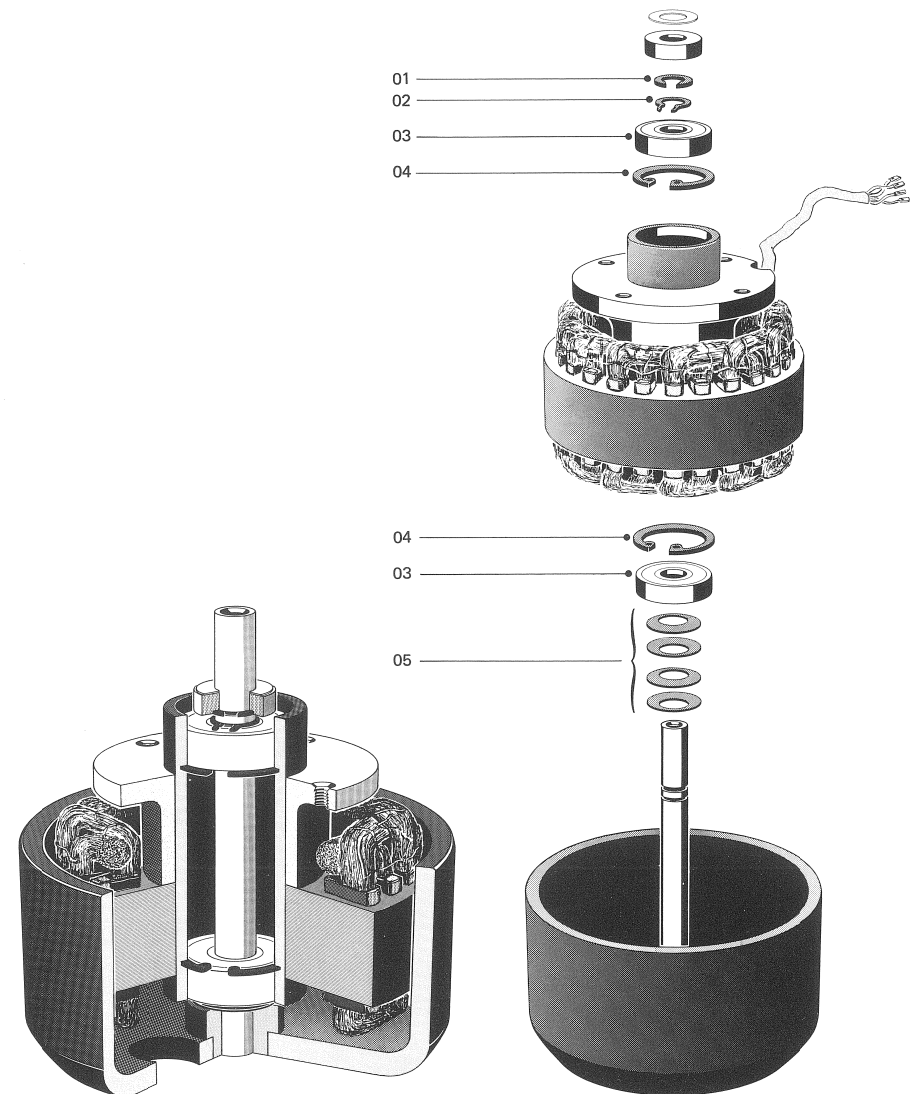

INDEX	QTY	PART NAME	ORDER NUMBER
G 1		Motor, Reel	
		In case of a defective stator, rotor, or shaft, exchange motor. (See also F — Brake System).	
		1 Motor, reel, assembled	1.021.205
	01	1 Clip, spring	24.99.0111
	02	1 Ring, retaining, external (ϕ 8 mm)	24.16.5080
	03	2 Bearing, ball EL 8 608	41.99.0105
04	2 Ring, retaining, (internal ϕ 22 mm)	24.16.4220	
05	2 Spring, belleville	37.02.0206	

G 1

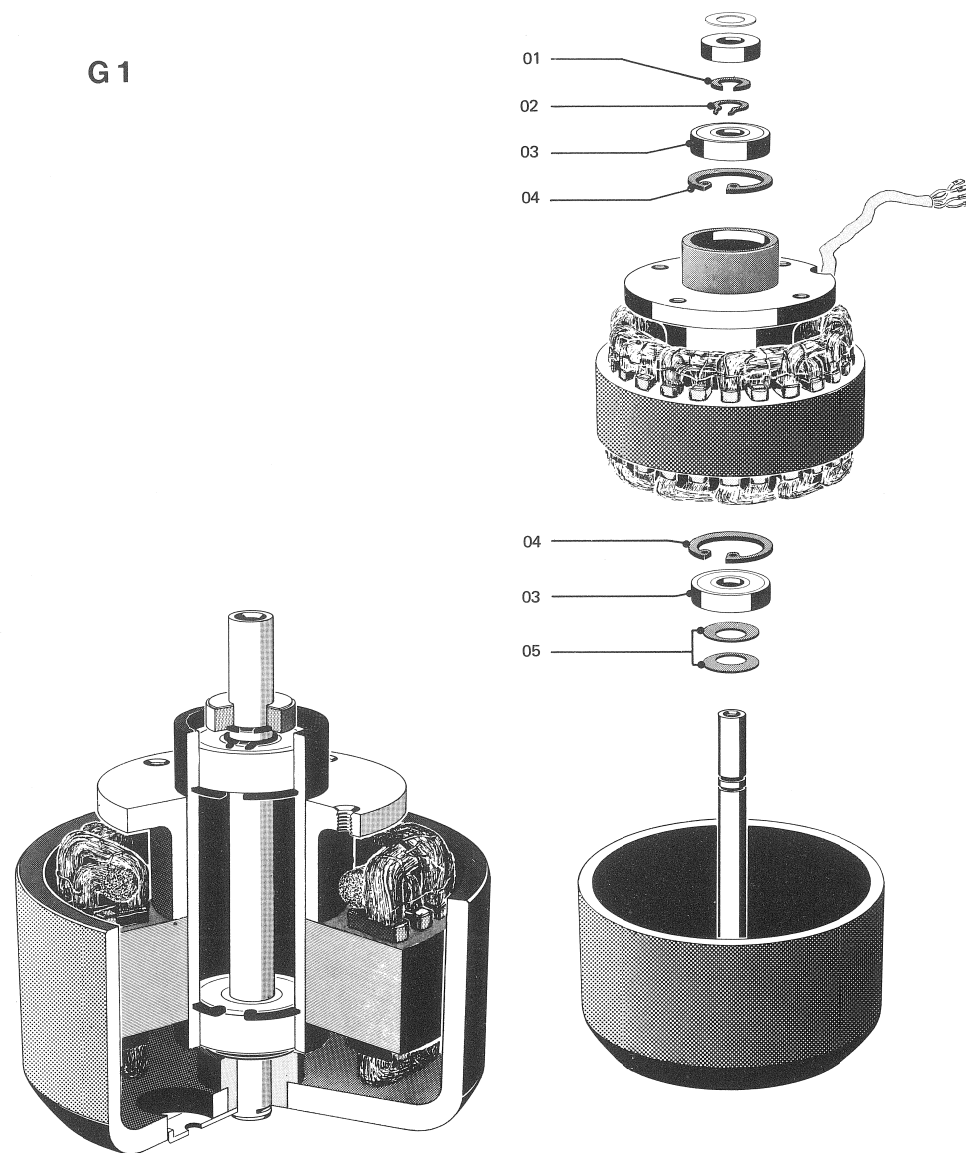

On reel motors of the type 1.021.200 the shaft lock must not be removed.

INDEX	QTY	PART NAME	ORDER NUMBER
H		Motor, Capstan	
01	1	Motor, capstan, assembled	
02 a *	1	Rotor	
02 b *		Rotor	1.021.103
03 a *	1	Shaft, capstan	1.077.200 - 09
03 b *		Shaft, capstan	1.077.200 - 01
04	2	Cap, plastic	1.077.220 - 02
05	2	Ring, felt	1.077.220 - 01
06	1	Bearing, ball	41. 99.0101
07	2	Ring, retaining, internal	24. 16.4220
08	2	Spring, belleville	37. 02.0106
09 a *	1	Clip, shaft	24. 99.0112
09 b *		Clip, shaft	22. 16.6104
10 a *	1	Device, no-turn	1.077.200 - 08
10 b *		Device, no-turn	1.077.200 - 05
11	1	Shield	1.077.200 - 03
12	2	Screw (M3 x 4)	21. 01.0352
13	1	Head, pick-up	1.077.240
14	1	Washer, antivibration	1.077.200 - 04
15	2	Screw (M3 x 6)	21. 99.0117
16	2	Washer, plain	23. 01.1032
17	4	Screw (M4 x 30)	21. 01.0464
18	1	Plate, screening	1.077.100 - 22
		* Suffix a or b denotes matching shaft, rotor and no-turn device	

Bend down lip when using new capstan shaft and no-turn device 10a on old rotors.

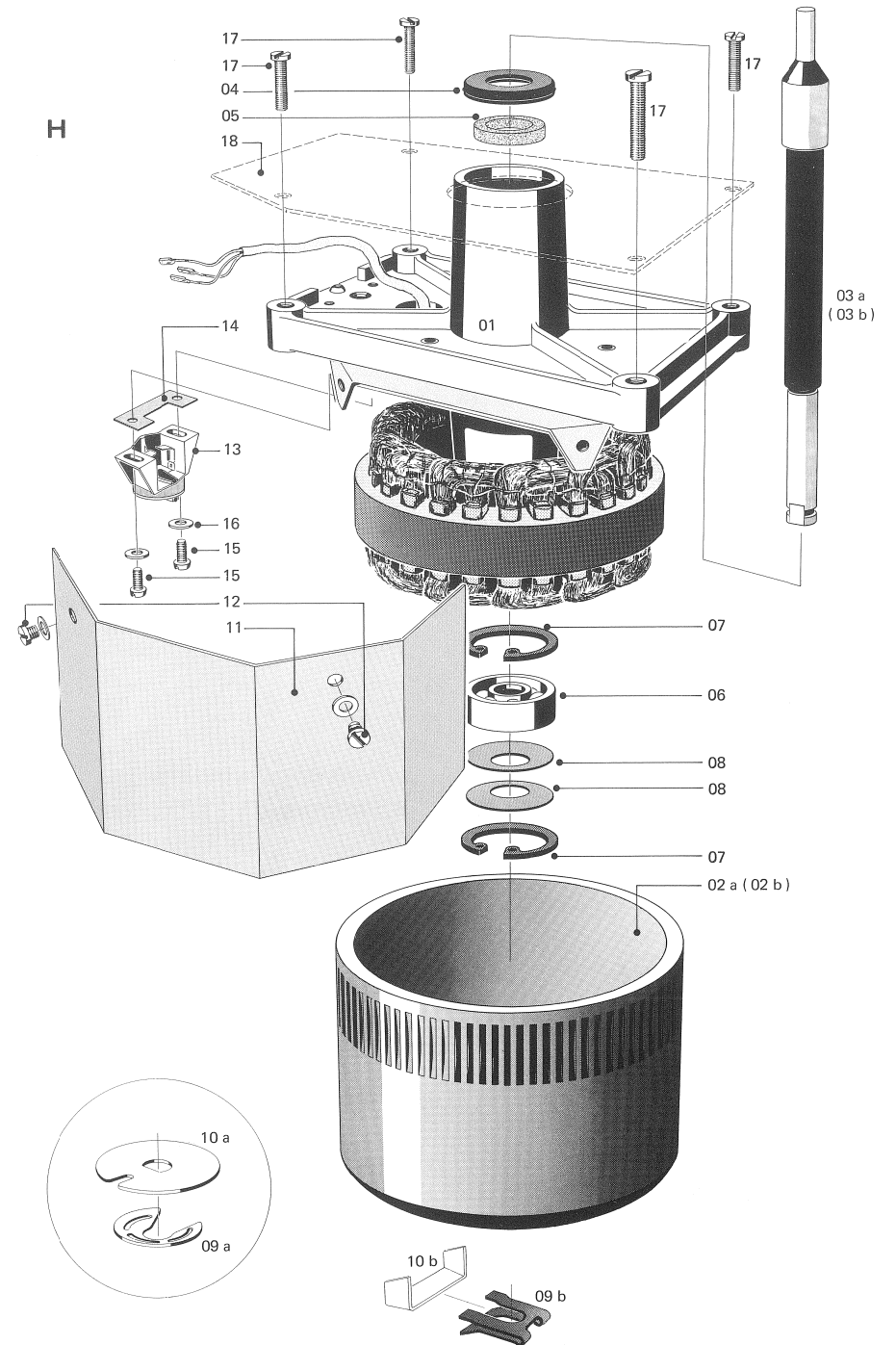
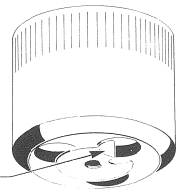

INDEX	QTY	PART NAME	ORDER NUMBER
J		Capstan motor with sleeve bearings	
		Modification effective from serial No. S 60483 and G 78003	
01	1	Motor, capstan, assembled	1.021.160
02	1	Rotor	1.021.161
03	1	Shaft, capstan	1.021.160.12
04	3	Cap, plastic	1.077.220-02
05	3	Ring, felt	1.077.220-01
06	2	Bearing, sleeve must not be removed	
07	1	Ring, spacer	1.021.160-08
08	1	Bearing, thrust	1.021.162
09	1	Washer, low-friction	1.021.160-09
10	2	Spring, belleville	37.02.0106
11	1	Ring, retaining, internal	24.16.4220
12	1	Shield	1.077.200-03
13	2	Screw (M3 x 4)	21.01.0352
14	1	Head, pick-up	1.077.240
15	1	Washer, antivibration	1.077.200-04
16	2	Screw (M3 x 6)	21.99.0117
17	4	Washer, plain	23.01.1032
18	4	Screw (M4 x 30)	21.01.0464
19	1	Plate, screening	1.077.100-22
20	1	Clip, shaft	1.021.160-10
		7,5/15 ips Recorder:	
		Motor, capstan, assembled, 7,5/15 ips	1.021.165
		shaft, capstan 7,5/15 ips	1.021.165.05

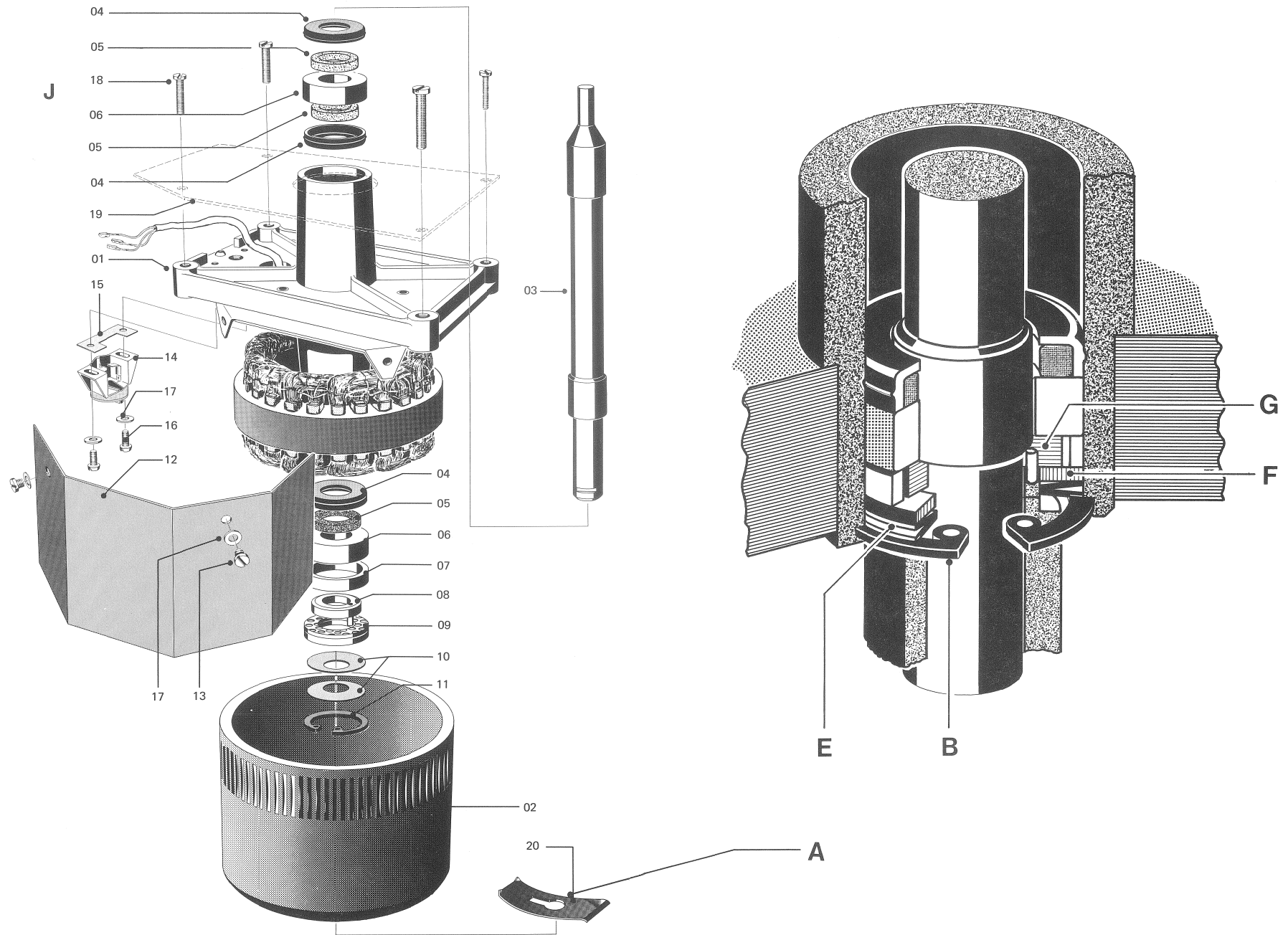

12.1. REVOX A77- DOLBY

12.1.1. Introduction

The DOLBY B Type Noise Reduction System is based on the same principles as the professional DOLBY A System, but is simplified and economical to permit its application in consumer tape recorders. The system is designed to reduce tape hiss by increasing the level of low-level signals in a variable range of high frequencies during recording, and automatically reducing the level during playback of the same locations in the program. Although no change is then heard in the original signal, the attenuation during playback results in a reduction of tape hiss. The amount of noise reduction achieved is approximately 10 dB (DIN weighting).

The basic Dolby B circuit can be switched to make it operate in either the "record" or "play" mode. For many applications, therefore, it is possible to work with one switchable record-play processor per channel. However, in order to allow simultaneous recording and monitoring of Dolby-processed tapes and track-to-track transfer of Dolby recordings, the Dolby version of the Revox A77 is equipped with separate recording and playback processors for each channel.

Because of the limited space available in the Revox A77, the plug-in power amplifiers cannot be accommodated in the Dolby version.

In order to realize the full subjective improvement in signal-to-noise ratio which the Dolby System can provide, it is essential that noise and hum in the program and other components used be substantially below the level of the tape hiss, since these noises, like all sounds of any kind which are part of the original program, will not be reduced or audibly affected in any other way by the Dolby System. Because the Dolby B System reduces noise only above 200 Hz, it is particularly important that low-frequency noise and hum be as low as possible. To avoid amplitude distortion when working with the Dolby System, the tape recorder must have a very linear frequency response.

12.1.2. Circuit Operation Record Processor 1.077.853

In addition to the actual processor, this printed circuit board also contains amplifiers and filters for each channel plus a calibration oscillator which is common to both channels. This oscillator is coupled to the input of each channel by separate 1 Mohm resistors. Power is supplied to the oscillator when the front panel switch is set to the "calibrate" position. The oscillator level is adjustable by means of potentiometer P 103 r which is pre-set at the factory. The oscillator frequency is approximately 800 Hz.

The signal at input 5(11) is amplified by Q1, Q2 from 9 mV to 200 mV.

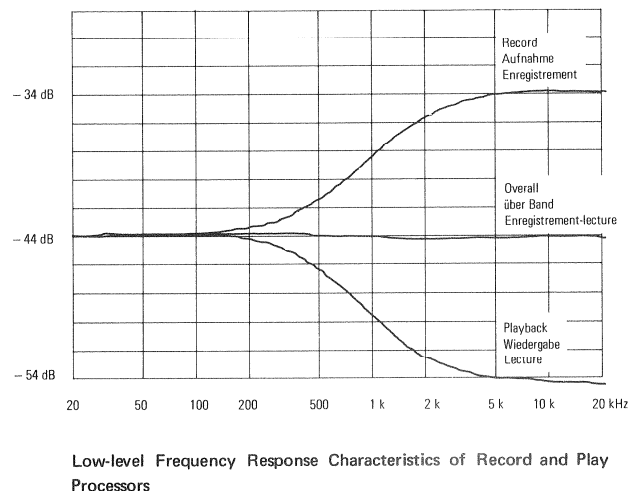

Fig. 12.1.-1.

From there it passes through the filter formed by L1, L2, C3—C7 which is intended to suppress interference from multiplex signals when recording stereo FM broadcasts. Furthermore, any unwanted signals above 20 kHz (e.g., residual bias and erase oscillator signals) are sufficiently attenuated by the active low pass filter built around transistor Q4 that they cannot upset the operation of the dynamic filter section of the noise reduction circuit. If the multiplex filter with its cut-off frequency of 14.5 kHz is not required, it may be disabled by a relay which operates on both channels. The audio signal at the output of the low pass filter Q4 is divided into a main channel and a side channel.

The main channel feeds the signal via R42 and the emitter follower Q9 directly to the output 1 (13).

In the side channel, the signal passes through the dynamic high pass filter formed by C11, R19, C12 and the drain-source path of FET Q5. When low-level signals are present, the FET is non-conductive and has a high drain-source resistance, so that only the first section of the filter C11, R 19 controls the response of the side chain. The output from this filter is then amplified by Q6, Q7 and recombined with the main signal at Q9 via the resistor R 41.

The gain of the side chain is so adjusted that at -40 VU, the combined signal at the output of Q9 is increased by 10 dB at 5 kHz. The graphs in Figure 12.1.-1. show the frequency response for low-level signals. The side-chain output signal is also fed to transistor Q8 where it is amplified, and then rectified and smoothed by the non-linear integrator D4, D5, R34, R36, C20, C21, the resulting D.C. voltage being returned to the gate of FET Q5.

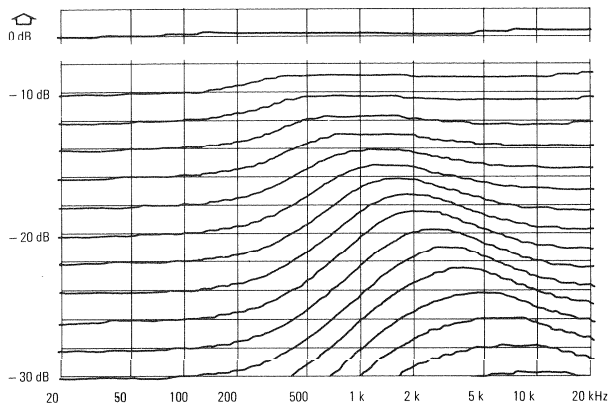

Record Processor Characteristics

Fig. 12.1.-2.

If a higher audio signal causes the D.C. voltage on the gate to exceed the bias point of the source — which is set with P 101 r(law control) — the drain-source path will become conductive. This then results in a change of the turn-over frequency of the second high pass branch formed by C12 and the drain-source resistance. With increasing input level, the proportion of the side channel signal added to the main-channel signal will become smaller, resulting in a frequency characteristic as shown in Figure 12.1.—2.

At 0 VU, the side channel component has become so small that the main signal will appear practically unaltered at the output, that is, it has a linear frequency characteristic.

The variable filter action is shown in Figure 12.1.—3. It shows the amplitude characteristics of test signals at different frequencies and at a low level (–42 VU, which is below the threshold of the compressor) in the presence of 0 VU signals of various frequencies which drive the compressor into gain reduction. When comparing this with a filter of fixed bandwidth, one will note that marked noise reduction is obtained at high frequencies in the presence of high-level signals of lower frequency.

A two-stage non-linear integrator is used in the side chain to avoid the generation of modulation products on transients.

For small signal level variations, diode D5 is non-conducting, so that the time constant of the RC combination R39, C24, provides considerable smoothing effect. On a sudden increase, however, D5 becomes conductive and quickly lowers the gain of the side chain. For large amplitude transients, the attack time will be reduced to 1.5 milliseconds, approximately. To avoid overshoots in the output during this interval, two clipping diodes D2, D3, are provided which respond to extreme transients only until the side chain has returned to its original operating point. As a result, the signal appearing at the output consists of a large amplitude undistorted main signal mixed with a small amplitudeclipped side chain signal. The distortion of the output signal is therefore small, and as the effect lasts for so short a time, inaudible.

12.1.2.

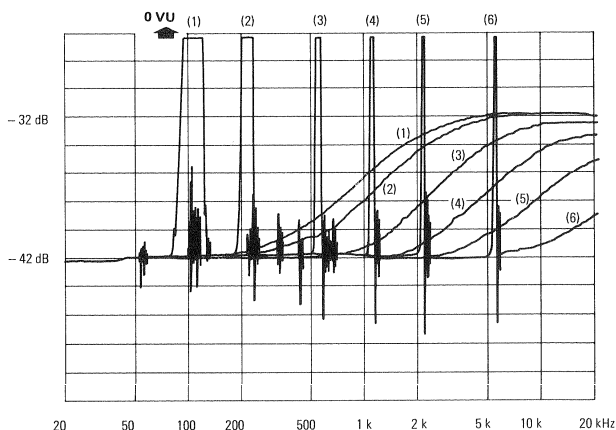

Low-level Frequency Response Characteristics of Record Processor under High-level Signal Conditions

Fig. 12.1.-3.

To prevent the erase oscillator from interfering with the control circuit, the gain of Q8 is greatly reduced at the frequency of the erase oscillator by the parallel resonant circuit L3, C22. Capacitors C19 and C20 give additional attenuation.

Playback Processor 1.077.852

The same basic circuit is used for the playback processor, but instead of the side chain being fed from the input, it is fed from the output. Furthermore, the phase of the output signal (and hence of the side chain signal) is opposite to that of the input so that the side chain forms a negative feedback element, and produces replay characteristics which are complementary to the record characteristics.

The playback processors for both channels are contained on one plug-in printed circuit board. In addition, this board contains the VU meter amplifier Q9, used for matching the the 100 m V levels to the VU meters. Potentiometer P 103 p adjusts the gain of that stage.

The signal arrives from input 9 (13) and is amplified by Q1, Q2, Q3 from 40 mV to the Dolby Level of 100 mV. The voltage divider formed by R14, R15, matches the output signal to the A77 internal operating level of 9 mV which then appears at point 11 (14).

In order to be able to work without Dolby noise reduction, the side chain signals can be shorted out by Q4, in the playback processor and by Q3 in the record processor. Both devices are activated by the Dolby "In-Out-" switch 50 on the front panel of the recorder.

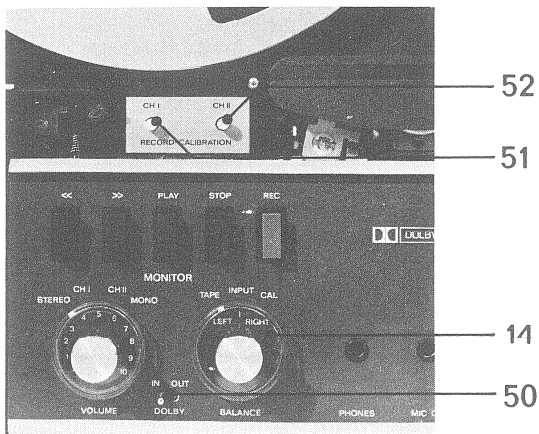

Fig. 12.1.-4.

12.1.3. Use of the Dolby Circuit in the Tape Recorder

To achieve correct performance both the record and playback sections must work at identical levels, that is, the tape recorder must have unity gain and a very linear frequency response from the output of the record processor to the input of the playback processor. All Dolby-encoded tapes must be recorded with the operation of the noise reduction circuitry referred to an absolute level of tape flux. Because the same flux level is also standardized for playback, interchangeability of Dolby-encoded tapes is assured. The standard tape flux is 185 nWb/m which corresponds to the Ampex Reference Level on Ampex calibration tapes with NAB equalization.

Any change in gain between the output of the record processor and the tape would be equivalent to a shift in the processor's characteristics. Differences in tape sensitivity must therefore be balanced out, using the RECORD CALIBRATION (51) / (52) control provided on the front panel for this adjustment.

Adjustment of REC CAL Control

1. Load the recorder with tape of the kind to be used.
2. Set record level controls (15) / (17) to zero.
3. Turn selector switch (14) to CAL.
4. Set the recorder to RECORD.
5. Adjust REC CAL controls (51) / (52) until each meter reads 0 VU.
6. Return selector switch (14) to INPUT or TAPE.

Be careful not to accidentally select the CAL position during source-tape switching while recording, or the calibration oscillator tone will be superimposed upon the signal being recorded.

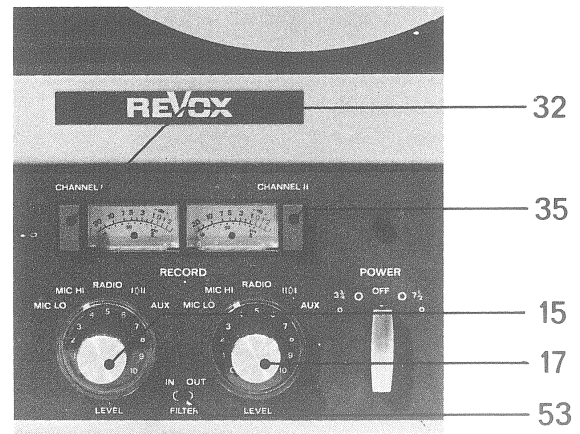

Fig. 12.1.-5.

- (14) on/off-tape monitor selector
 - (15) Record volume control Ch I
 - (17) Record volume control Ch II
 - (32) Record pre-selector Ch I
 - (35) Record pre-selector Ch II
 - (50) DOLBY IN/OUT
Switch to activate or to deactivate the DOLBY noise reduction circuits.
- RECORD CALIBRATION
- (51) Record Calibration for Channel I
 - (52) Record Calibration for Channel II
 - (53) FILTER IN/OUT
Switch for turning the multiplex filter on or off.

Index Numbers

The index numbers 50 to 53 are used for identifying the additional operating controls on the DOLBY equipped REVOX A77 tape recorder. All other index numbers make reference to the operating instructions for the standard version except for the following changes:

Standard Recorder

- Button Speakers off (41)
- Button Reel Motors off (42)
- Monitor selector (14):
 - Position NAB
 - Position IEC

DOLBY Version

- omitted
- omitted
- corresponds to TAPE replaced by Calibrate (new function)

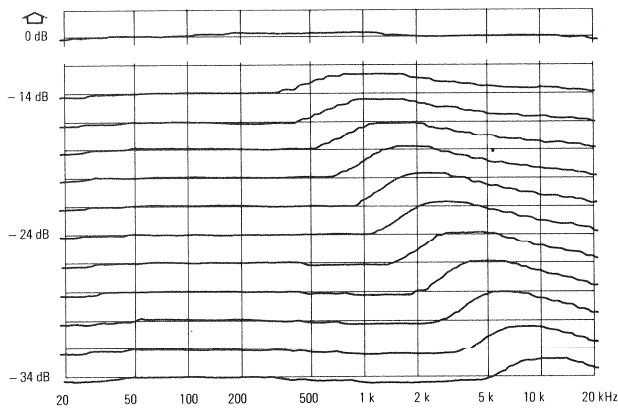

Mismatch Response: 2 dB Gain Between Record and Play Processors

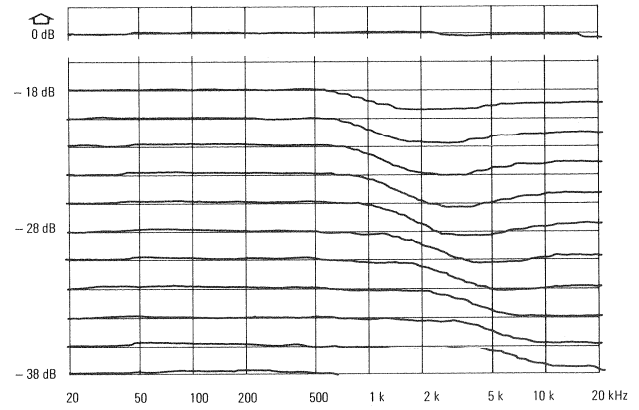

Mismatch Response: 2 dB Loss Between Record and Play Processors

Fig. 12.1.-6.

Fig. 12.1.-7.

12.1.4. Matching and Mismatching

The frequency response of a record/playback processor chain connected in series should be within a tolerance of ± 1 dB. Typically, deviations much smaller than this are achieved. Although mismatching may arise from a number of causes, most commonly it is the result of incorrect adjustment of the signal channel between the record and playback processors for unity gain, either on a wide-band basis or at high frequencies. The effect of such gain errors (wideband) are shown in Figures 12.1.-6. and 12.1.-7. Under dynamic program conditions, response deviations of this magnitude are inaudible.

Other sources of error are incorrect alignment or a build-up of component tolerances. Individual variations in FET's are mainly responsible for errors in the processor characteristics.

It can be seen that the region most sensitive to mismatch is that at a level of about -25 VU; the error will be less at higher and lower levels.

Basic Printed Circuit Board 1.077.854

This board carries both plug-in processors and all of the required interconnections. Also on this board is a Zener diode to derive the $+7.2$ V from the 21 V supply and an RC combination to filter out any hum in the $+27$ V supply for the relay in the record processor.

All interconnections between the switch board and the printed circuit cards carrying the calibration potentiometers, the power supply, the VU meters and the switches "Dolby in/out", "Filter in/out" and "Calibration" are either soldered or plugged onto this board.

Calibration Potentiometer Board 1.077.342

Two potentiometers are mounted on this board for individual front panel adjustment of both record channels to match them to tapes of different sensitivity.

Switchboard 1.077.426

This differs from the corresponding board in the standard version of the A77 in that it carries the pluggable inputs and outputs for the Dolby processor. The NAB/IEC switch has been modified to carry the function of switching the VU meters for metering level from the tape as well as the signal from the record amplifier which is normally metered during recording. Equalization characteristics remain NAB in all three positions of the monitor selector (Tape-Input-Calibration).

Power Transformer 1.077.524

The transformer differs from the standard version in that the wire of the winding for the regulated 21 V supply has been changed from 0.5 mm diameter to 0.9 mm. Both 32 V windings for the power amplifiers have been omitted.

Reel Motors Off Switch

This switch had to be omitted and the two record calibration potentiometers are installed in its place.

VU Meter Level

VU calibration is effected on the DOLBY playback board. The calibration controls in the A77 record amplifiers are disabled.

**Reproducer Test Tapes NAB 7 1/2 ips for
REVOX A77 Dolby 50/3180 μ sec**
(recording of Nov.30 1971)

The tapes contain the following frequencies and levels:

1 kHz	30 s	AMPEX Operating Level
1 kHz	8 s	- 10 dB
10 kHz	60 s	- 10 dB
Frequency response test section: all levels - 20 dB 8 sec.		
1k, 40, 63, 125, 250, 500, 1k, 2k, 4k, 6,3k, 8k, 10k, 12,5k, 14k, 16k, 18k		
1k		- 10 dB

DIN 19 S (70 μ sec) Standard Test Tape issue 1970, No. 5608 was used as the frequency response reference. An Ampex Test Tape (Nov. 71) was used as a level reference.

To obtain the correct frequency response the following correction factors were used (70 μ sec. to 50/3180 μ sec).

40	Hz	+ 3,6 dB
60		+ 1,8
125		+ 0,1
250		- 0,4
500		- 0,2
1	k	0
2		+ 0,7
4		+ 1,7
6,3		+ 2,1
8		+ 2,3
10		+ 2,4
12		+ 2,5
15		+ 2,5

The DIN Standard Test Tape was used because the Ampex tape contains different frequencies and it does not extend beyond 15 kHz.

**REVOX A77 with DOLBY Noise Reduction System,
Additional Technical Data**

All measurements taken with REVOX 601 tape, DOLBY electronics switched on.

2-Track Version (values for the 4-Track Version are shown in parenthesis)

Signal to Noise Ratio, off tape, weighted as per CCIT:

At 7 1/2 ips. better than 67 dB (65 dB)
At 3 3/4 ips. better than 64 dB (62 dB)

Weighted as per ASA A:

At 7 1/2 ips. better than 70 dB (67 dB)
At 3 3/4 ips. better than 67 dB (65 dB)

Distortion measured off tape, 500 Hz
Peak Level (assumed to be +6 VU)

At 7 1/2 ips. better than 1.0 % (1.5 %)
At 3 3/4 ips. better than 1.5 % (2.0 %)

Operating Level 0 dB (100 %):

At 7 1/2 ips. better than 0.5 % (0.5 %)
At 3 3/4 ips. better than 0.5 % (1.0 %)

All other performance data are identical with the data for the standard version of the A77 recorder.

ALIGNMENT INSTRUCTIONS REVOX A 77 DOLBY

Hem	Operation	Alignment Procedure	Test Equipment	Tape Speed ips	Frequency	Voltage	Testpoint	Where to adjust
1.	Adjustment of regulated-Voltage	Adjust exactly to nominal 21 volts	Multimeter	7.5		+ 21 V DC	Yellow wire ED 1	P 106
2.	Adjustment of Tacho Head (S.M. 6.2.1.)	Alter head position to obtain specified tacho voltage	Electronic Voltmeter	3.75		40 m V AC	E1 – E2	mounting screws of tacho-head
3.	Bias-Filter record (S.M. 6.4.3.)	Adjust for minimum voltage	Electronic Voltmeter	7.5	120 kHz	< 300 mV	see fig. 6.4.—63/64	L 501
4.	Bias-Filter, replay (S.M. 6.4.4.)	Adjust for minimum voltage	Electronic Voltmeter	7.5	120 kHz	< 50 mV	Wiper P 801	L 801
5.	Motor Speed (S.M. 6.2.2.)	Adjust tacho frequency (measure over at least 10 sec.)	Digital Counter	7.5 3.75	1601 Hz 800 Hz	10 V	Pin 2 on T 201	T 201 P 201
6.	Oscillator and Bias adjust	As per Service Manual 6.4. Adjust dummy load	Electr. Voltmeter Digital Counter Digital Counter	7.5 7.5 7.5	120 kHz 120 kHz ± 5 kHz 120 kHz ± 5 kHz	2 Track 21 VAC	HB3—HB6 HB3—HB6 HB3—HB6	blue & orange wire Dummy load L 601
7.	DOLBY record adjustments DOLBY "OUT" DOLBY "IN"	Turn FET-bias off, set gain control to minimum amplification DOLBY switch 50 in position "OUT" Connect Audio Generator to "AUX" inputs, Adjust level on Generator Adjust level on Generator DOLBY switch in pos. "IN" measure voltage rise on DOLBY output Level adjustment Level reduction by 2 dB	T19 T 19 VTVM T 19 VTVM T 19 VTVM T 19 VTVM T 19 VTVM		5 kHz 5 kHz 5 kHz 5 kHz 5 kHz 5 kHz	~ 0.45 mV 3 mV 2.6 mV ~ 7 mV (+8 dB) 8.2 mV (+10 dB) -2 dB	 P1, P2 P3, P4 P3, P4 P3, P4 P3, P4	P 101 r (CH I, CH II) P 102 r (CH I, CH II) Generator Generator Generator P 102 r P 101 r
8.	DOLBY replay adjustments DOLBY "OUT" DOLBY "IN"	Turn FET bias off, Set gain control to min. amplification. DOLBY switch 50 in pos. "OUT" Connect Audio Generator to DOLBY inputs (with test clips). Adjust level on generator DOLBY switch 50 in pos. "IN" Adjust level reduction on DOLBY outputs Level increase by 2 dB	T 19 T 19 VTVM T 19 VTVM T 19 VTVM		5 kHz 5 kHz 5 kHz 5 kHz	7.6 mV -10 dB = 2.4 mV + 2 dB = 3 mV	P5, P6 P7, P8 P7, P8 P7, P8	P 101 p (CH I, CH II) P 102 p (CH I, CH II) P 102 p P 101 r
9.	VU-Meter calibration	Connect Audio Generator to "AUX" inputs, Adjust generator output level Calibrate VU-meters	T 19 or generator		1 kHz 1 kHz 1 kHz	~ 13 mV 100 mV 0 VU	P1, P2	P 103 p
10.	Balance Adjustment							
11.	Playback head azimuth adjustment	As per Service Manual sections 6.3.1. and 6.3.2.	DOLBY reference tape					
12.	Playback level off test tape	Playback level calibration	VU-Meter	7.5		185 nWb/m = 0 VU		P 801 print 077.720
13.	Frequency response check	As per Service Manual 6.3.4. and additional instructions.						
14.	Record head azimuth adjustment	"REC. CAL" pot-meters 51/52 fully ccw. T19 generator level (~13 mV) adjusted for 0 VU indication. Reduce generator level -20 dB Adjust azimuth as per S.M. 6.5.3.			10 kHz 10 kHz	VU = 0 dB -20 dB		
15.	RF Bias Adjustment	As per Service Manual 6.5.2. Δ U for Scotch 207	T19	7.5 3.75		4 dB 5 dB	OUTPUT CH I, CH II	

16.	Record Level and calibration oscillator adjustments	Depress button -6 dB on T19, position "INPUT" T19 Adjust generator to read -1 dB on both VU-Meters "REC.CAL" potmeters 51/52 fully ccw, increase generator level, Monitor selector 14 in position "TAPE" Switch to record and adjust potentiometer P503 (record amplifier 1.077.705) to 0dB on VU-Meter. Reduce Generator Level Raise record level "REC.LEVEL" Potmeter fully ccw, turn monitor selector 14 to position "CAL" and adjust calibration oscillator	T19 VU Meter Generator VU Meter Generator VU-Meter VU-Meter		1 kHz	- 1 dB +10 dB 0 dB -10 dB 0 dB 0 dB		"REC.LEVEL" Potmeter 15/17 "REC.CAL" potmeter 51/52 P 103 r
17.	Checking the DOLBY Frequency Response	Reduce T19 generator level by 20 dB, Turn DOLBY switch 50 to position "IN" Frequency response tolerances Level difference Mono-Stereo Attenuation of MPX-filter	T19 T 19 VTVM	7.5 3.75	30-20000 Hz 50-15000 Hz 30-16000 Hz 50-10000 Hz 10 kHz 18 kHz	-20 dB + 2/-3 dB \pm 1,5 dB + 2/-3 dB \pm 1,5 dB 0,5 dB - 25 dB	OUTPUT OUTPUT OUTPUT OUTPUT OUTPUT	
18.	Checking the Output Level	T19 generator at 1 kHz Adjust record level to 0 VU Measure output level (radio output) Level difference Mono-Stereo	T 19 T 19 VTVM		1 kHz	560mV \pm 1dB 0,5 dB	Radio Output	
19.	Distortion Measurement	Measure 3rd harmonic Values independent of DOLBY switch position	T19 distortion analyzer	7.5 3.75 7.5 3.75	1.5 kHz 1.5 kHz 1.5 kHz 1.5 kHz	+ 6 dB + 6 dB 0 VU 0 VU	1,5 % 2 % 0,5 % 1 %	
20.	Noise measurement off tape weighted/unweighted	DOLBY-switch 50 position "IN" DOLBY-switch 50 position "OUT" weighting characteristics as per CCIT (values as per ASA A, see additional technical data)	T19	3.75 7.5 3.75 7.5	unweighted weighted unweighted weighted unweighted weighted unweighted weighted	4-track -53 dB -62 dB -56 dB -65 dB -52 dB -53 dB -55 dB -56 dB	2-track -64 dB -67 dB	
21.	Amplifier noise (without tape) weighted/unweighted	Recorder in "PLAY" mode, all noise readings with reference to +6 VU, Tolerances: Monitor selector 14 in position "INPUT"		7.5 3.75	unweighted weighted unweighted weighted	> 58 dB > 68 dB > 58 dB > 64 dB > 75 dB		
22.	Crosstalk rejection MONO	As per S.M. 6.6.5., adjust trimpot P305, if values differ between DOLBY IN and DOLBY OUT.						
23.	Crosstalk rejection STEREO	As per S.M. 6.6.6.						
24.	Erase efficiency	As per S.M. 6.6.4.						
25.	Final check	MONO-STEREO switch, track to track transfer, input sensitivity, noise voltage, S/N ratio in pos. "MICRO" (> 45 dB) mechanical inspection						

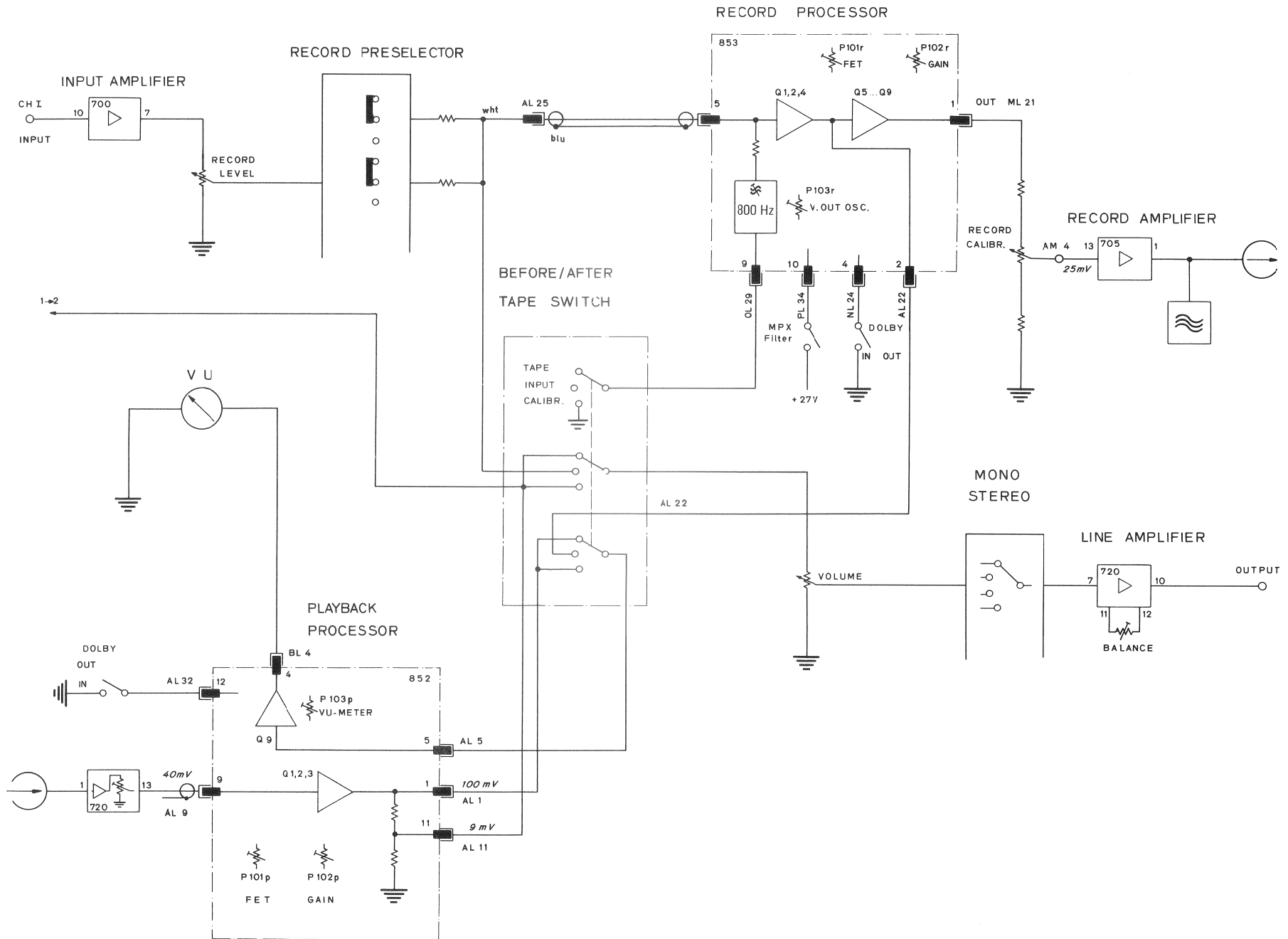

Function Diagram A77 DOLBY

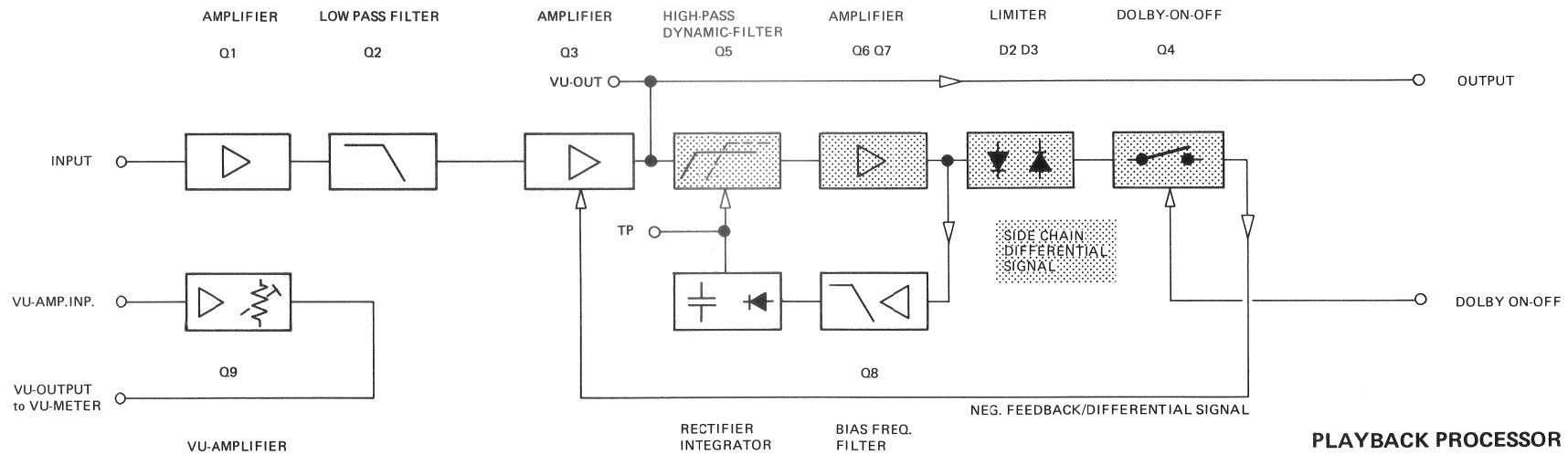
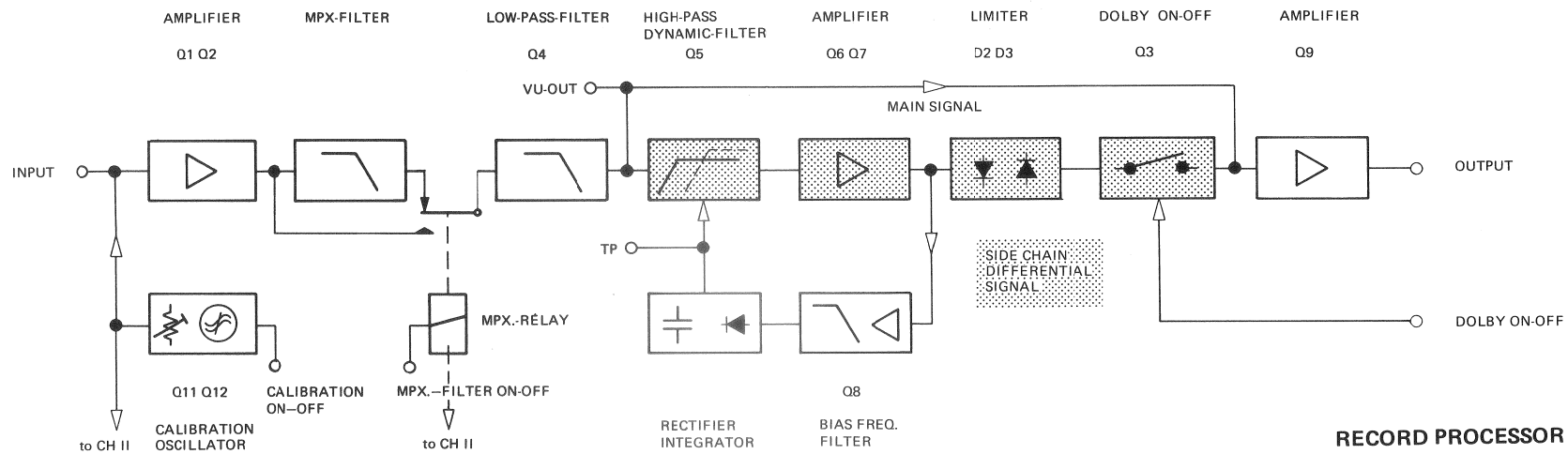

Block Diagram A77 DOLBY

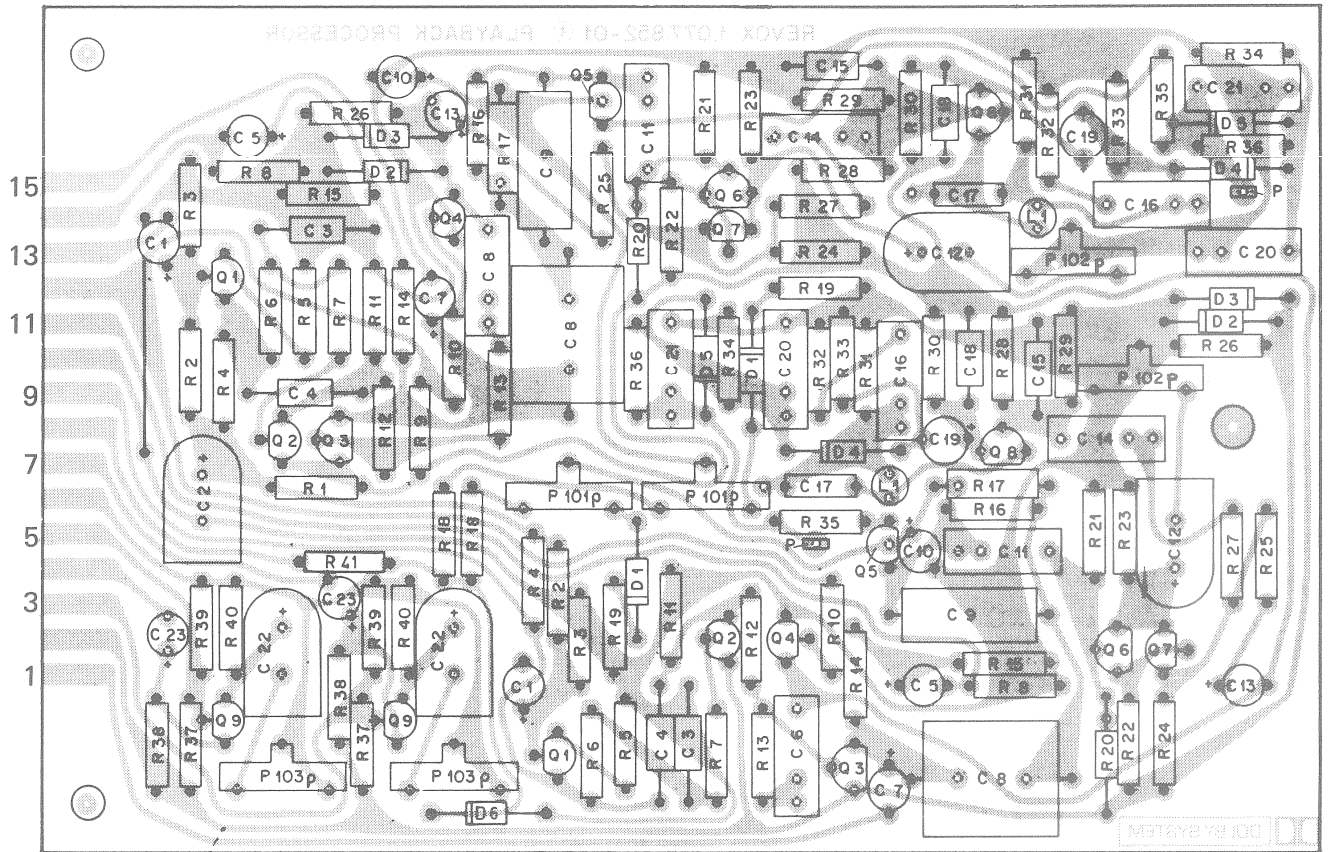

Playback Processor 1.077.852

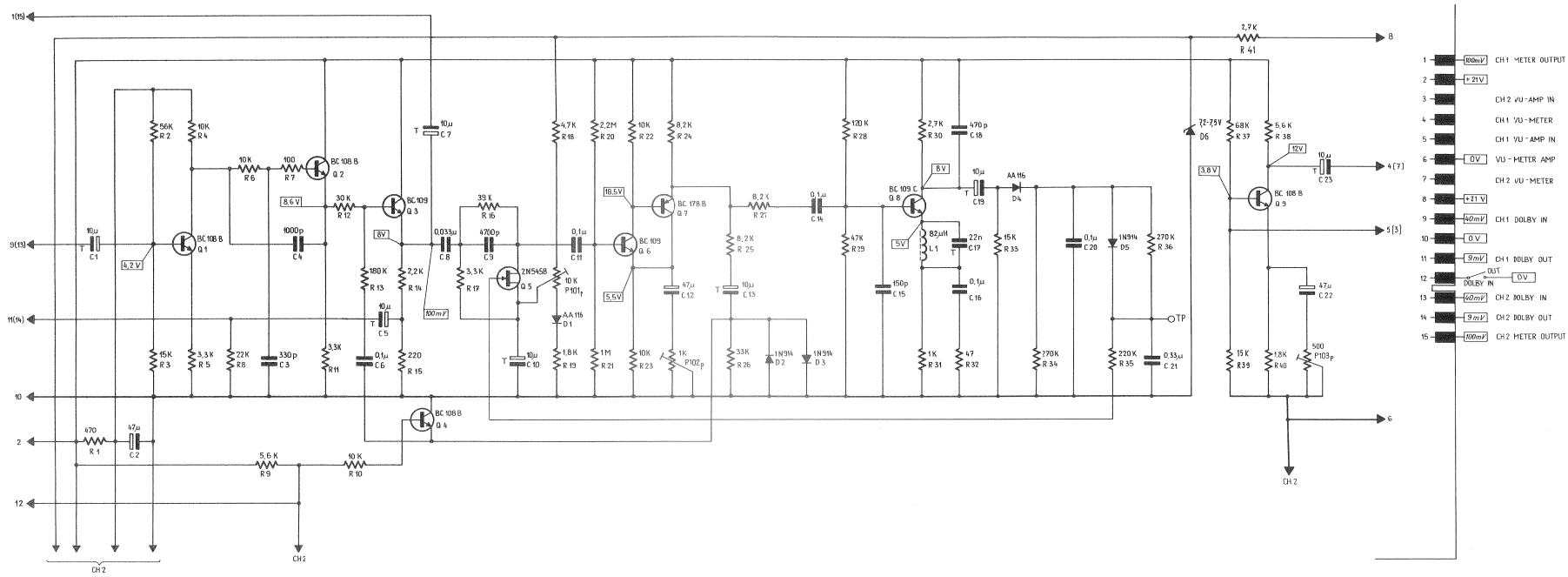

IDENTIFICATION	PART NAME	TYPE / REMARKS	Unspecified carbon film resistors:	**
			1/8 W - 5 %	Commercial types
			SPECIFICATIONS	ORDER NUMBER
	Playback Processor 1.077.852	assembled		1.077.852
C 1	Capacitor	tantalum	10 μ F - 50% - 16V	* *
C 2	Capacitor	elektrolytic	47 μ F - 100% - 25V	* *
C 3	Capacitor	polystyrene	330 pF - 5% - 63V	* *
C 4	Capacitor	polystyrene	1 nF - 5% - 25V	* *
C 5	Capacitor	tantalum	10 μ F - 50% - 16V	* *
C 6	Capacitor	polyester	0.1 μ F - 20% - 160V	* *
C 7	Capacitor	tantalum	10 μ F - 50% - 16V	* *
C 8	Capacitor	polystyrene	33 nF - 1% - 63V	* *
C 9	Capacitor	polystyrene	4.7 μ F - 1% - 63V	* *
C 10	Capacitor	tantalum	10 μ F - 50% - 16V	* *
C 11	Capacitor	polyester	0.1 μ F - 20% - 160V	* *
C 12	Capacitor	electrolytic	47 μ F - 100% - 25V	* *
C 13	Capacitor	tantalum	10 μ F - 50% - 25V	* *
C 14	Capacitor	polyester	0.1 μ F - 20% - 160V	* *
C 15	Capacitor	polystyrene	150 pF - 5% - 63V	* *
C 16	Capacitor	polyester	0.1 μ F - 5% - 100V	* *
C 17	Capacitor	polyester	22 nF - 5% - 250V	* *
C 18	Capacitor	polystyrene	470 pF - 5% - 63V	* *
C 19	Capacitor	tantalum	10 μ F - 50% - 16V	* *
C 20	Capacitor	polyester	0.1 μ F - 20% - 160V	* *
C 21	Capacitor	polyester	0.33 μ F - 20% - 63V	* *
C 22	Capacitor	elektrolytic	47 μ F - 10% - 25V	* *
C 23	Capacitor	tantalum	10 μ F - 50% - 16V	* *
D 1	Ge - Diode	AA 116		* *
D 2	Si - Diode	1N 914		* *
D 3	Si - Diode	1N 914		* *
D 4	Ge - Diode	AA 116		* *
D 5	Si - Diode	1N 914		* *
D 6	Z - Diode		7.5 V - 5% - 0.4 W	* *
P 1	Flat - Connector			54.02.0320
P 101	Trim - Potentiometer		10 k - 20% - 0.15 W	* *
P 102	Trim - Potentiometer		1 k - 20% - 0.15 W	* *
P 103	Trim - Potentiometer		500 - 20% - 0.15 W	* *
Q 1	Transistor	BC 108 B		* *
Q 2	Transistor	BC 108 B		* *
Q 3	Transistor	BC 109 C		* *
Q 4	Transistor	BC 108 B		* *
Q 5	Transistor	2N 5458		* *
Q 6	Transistor	BC 109 C		* *
Q 7	Transistor	BC 178 B		* *
Q 8	Transistor	BC 109 C		* *
Q 9	Transistor	BC 108 B		* *

IDENTIFICATION	PART NAME	TYPE / REMARKS	Unspecified carbon film resistors:	**
			1/8 W - 5 %	Commercial types
			SPECIFICATIONS	ORDER NUMBER
R 1	Resistor	carbon film	470	* *
R 2	Resistor	carbon film	56 k	* *
R 3	Resistor	carbon film	15 k	* *
R 4	Resistor	carbon film	10 k	* *
R 5	Resistor	carbon film	3.3 k	* *
R 6	Resistor	carbon film	10 k	* *
R 7	Resistor	carbon film	100	* *
R 8	Resistor	carbon film	22 k	* *
R 9	Resistor	carbon film	5.6 k	* *
R 10	Resistor	carbon film	10 k	* *
R 11	Resistor	carbon film	3.3 k	* *
R 12	Resistor	carbon film	33 k	* *
R 13	Resistor	carbon film	180 k	* *
R 14	Resistor	carbon film	2.2 k	* *
R 15	Resistor	carbon film	220	* *
R 16	Resistor	carbon film	39 k	* *
R 17	Resistor	metal film	3.3 k - 1% - 0.33 W	* *
R 18	Resistor	carbon film	4.7 k	* *
R 19	Resistor	carbon film	1.8 k	* *
R 20	Resistor	carbon film	2.2M - 5% - 0.25 W	* *
R 21	Resistor	carbon film	1 M	* *
R 22	Resistor	carbon film	10 k	* *
R 23	Resistor	carbon film	10 k	* *
R 24	Resistor	carbon film	8.2 k	* *
R 25	Resistor	carbon film	8.2 k	* *
R 26	Resistor	carbon film	33 k	* *
R 27	Resistor	carbon film	8.2 k	* *
R 28	Resistor	carbon film	120 k	* *
R 29	Resistor	carbon film	47 k	* *
R 30	Resistor	carbon film	2.7 k	* *
R 31	Resistor	carbon film	1 k	* *
R 32	Resistor	carbon film	47 k	* *
R 33	Resistor	carbon film	15 k	* *
R 34	Resistor	carbon film	270 k	* *
R 35	Resistor	carbon film	220 k	* *
R 36	Resistor	carbon film	270 k	* *
R 37	Resistor	carbon film	68 k	* *
R 38	Resistor	carbon film	5.6 k	* *
R 39	Resistor	carbon film	15 k	* *
R 40	Resistor	carbon film	1.8 k	* *
R 41	Resistor	carbon film	2.5 k	* *
L 1	HF - choke		82 μ H - 5%	62.02.4820

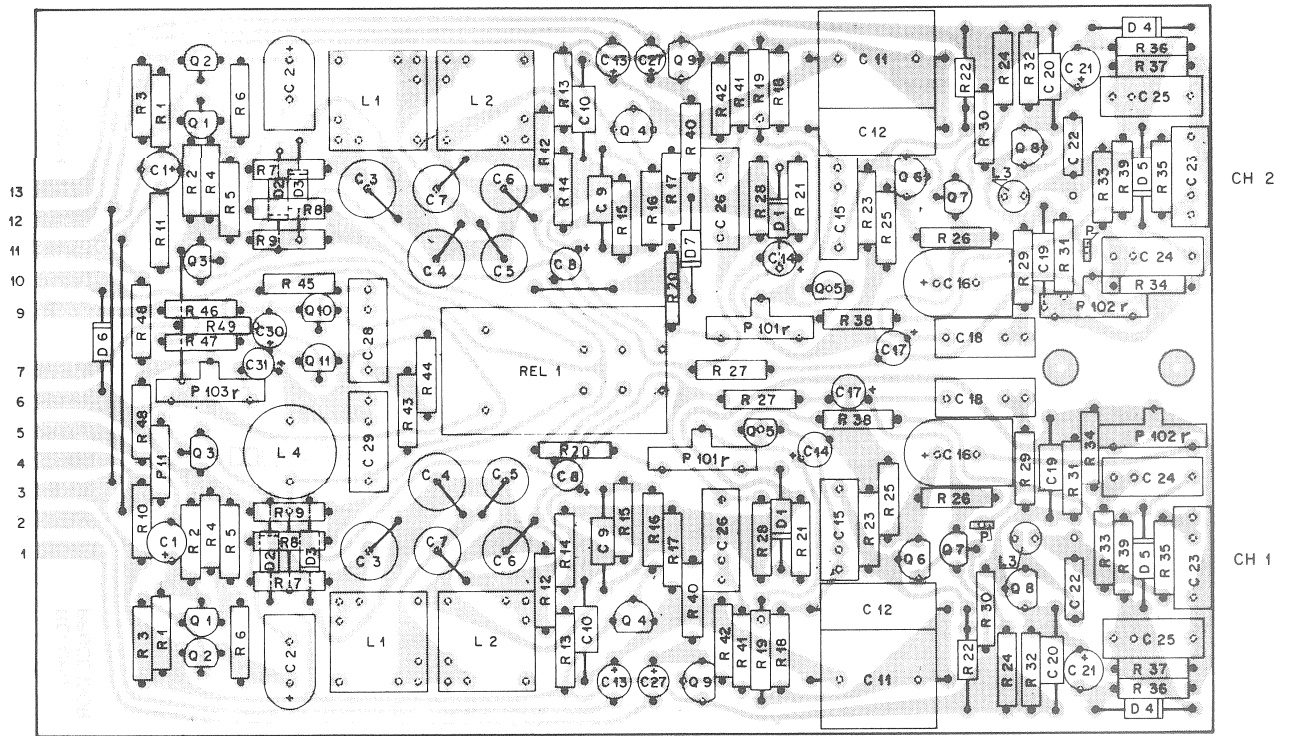

Record Processor 1.077.853

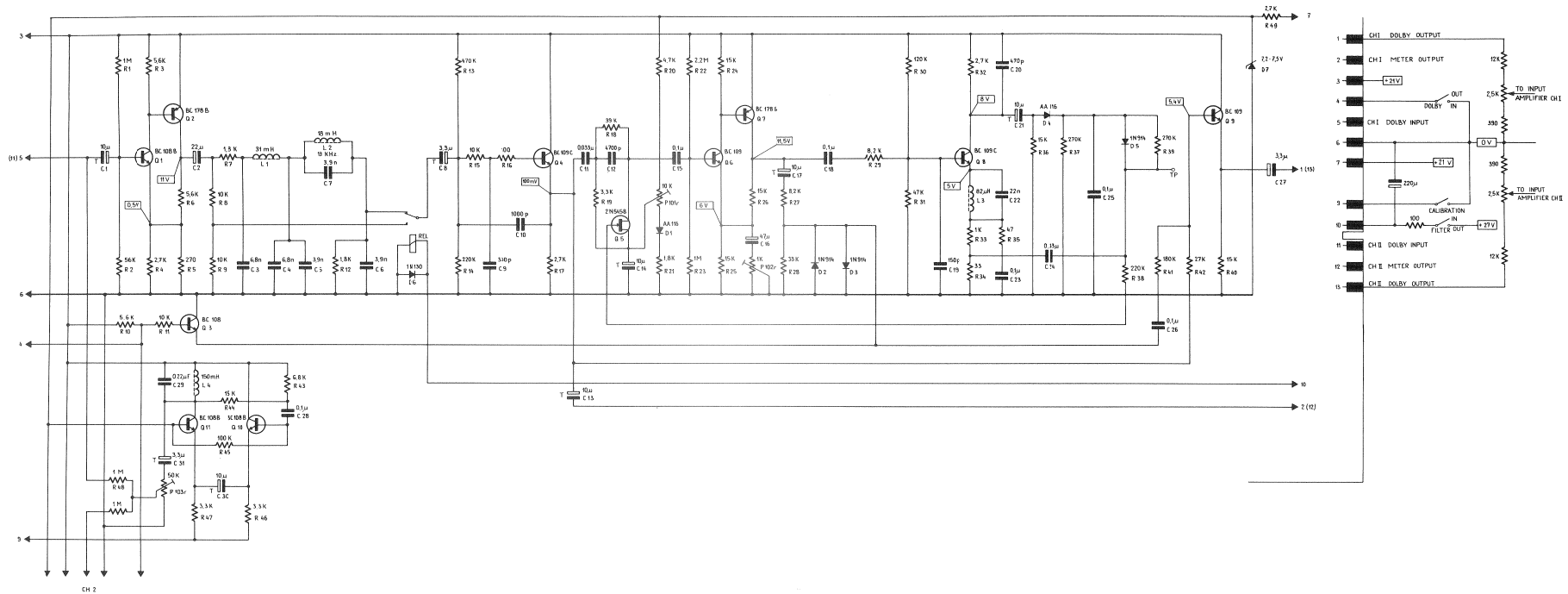

			Unspecified carbon film resistors: 1/8 W - 5 %	** Commercial types
IDENTIFICATION	PART NAME	TYPE / REMARKS	SPECIFICATIONS	ORDER NUMBER
	Record Processor 1.077.853	assembled		1.077.853
C 1	Capacitor	tantalum	10 μ F - 50% - 25V	* *
C 2	Capacitor	elektrolytic	22 μ F - 100% - 25V	* *
C 3	Capacitor	polystyrene	6.8 nF - 2% - 63V	* *
C 4	Capacitor	polystyrene	6.8 nF - 2% - 63V	* *
C 5	Capacitor	polystyrene	3.9 nF - 2% - 63V	* *
C 6	Capacitor	polystyrene	3.9 nF - 2% - 63V	* *
C 7	Capacitor	polystyrene	3.9 nF - 2% - 63V	* *
C 8	Capacitor	tantalum	3.3 μ F - 50% - 16V	* *
C 9	Capacitor	polystyrene	330 pF - 5% - 25V	* *
C 10	Capacitor	polystyrene	1 nF - 5% - 25V	* *
C 11	Capacitor	polystyrene	33 nF - 1% - 63V	* *
C 12	Capacitor	polystyrene	4.7 nF - 1% - 63V	* *
C 13	Capacitor	tantalum	10 μ F - 50% - 16V	* *
C 14	Capacitor	tantalum	10 μ F - 50% - 16V	* *
C 15	Capacitor	polyester	0.1 μ F - 20% - 160V	* *
C 16	Capacitor	elektrolytic	47 μ F - 100% - 25V	* *
C 17	Capacitor	tantalum	10 μ F - 50% - 16V	* *
C 18	Capacitor	polyester	0.1 μ F - 20% - 160V	* *
C 19	Capacitor	polystyrene	150 pF - 5% - 25V	* *
C 20	Capacitor	polystyrene	470 pF - 5% - 25V	* *
C 21	Capacitor	tantalum	10 μ F - 50% - 25V	* *
C 22	Capacitor	polyester	22 nF - 5% - 250V	* *
C 23	Capacitor	polyester	0.1 μ F - 5% - 100V	* *
C 24	Capacitor	polyester	0.33 μ F - 20% - 63V	* *
C 25	Capacitor	polyester	0.1 μ F - 20% - 160V	* *
C 26	Capacitor	polyester	0.1 μ F - 20% - 160V	* *
C 27	Capacitor	tantalum	3.3 μ F - 50% - 16V	* *
C 28	Capacitor	polyester	0.1 μ F - 20% - 160V	* *
C 29	Capacitor	polyester	0.22 μ F - 20% - 100V	* *
C 30	Capacitor	tantalum	10 μ F - 50% - 16V	* *
C 31	Capacitor	tantalum	3.3 μ F - 50% - 16V	* *
D 1	Ge - Diode	AA 116		* *
D 2	Si - Diode	1N 914		* *
D 3	Si - Diode	1N 914		* *
D 4	Ge - Diode	AA 116		* *
D 5	Si - Diode	1N 914		* *
D 6	Si - Diode	1N 4448		* *
D 7	Z - Diode		7.5 V - 5% - 0.4 W	* *
P 1	Flat - connector			54.02.0320
K 1	Relay		24 V - 0.3 A	56.04.0126

				Unspecified carbon film resistors: 1/8 W - 5 %	** Commercial types
IDENTIFICATION	PART NAME	TYPE / REMARKS	SPECIFICATIONS	ORDER NUMBER	
L 1	Filter choke		31 mH - assembled	1.022.134	
L 2	Filter choke		18 mH - assembled	1.022.133	
L 3	HF - choke		82 μ F - 5 %	62.02.4820	
L 4	HF - choke		150 mH - 5 %	62.02.3154	
P 101	Trim - Potentiometer		10k - 20% - 0.15W	* *	
P 102	Trim - Potentiometer		1k - 20% - 0.15W	* *	
P 103	Trim - Potentiometer		50k - 20% - 0.15W	* *	
Q 1	Transistor	BC 108 B		* *	
Q 2	Transistor	BC 178 B		* *	
Q 3	Transistor	BC 108 B		* *	
Q 4	Transistor	BC 109 C		* *	
Q 5	Transistor	2N 5458		* *	
Q 6	Transistor	BC 109 C		* *	
Q 7	Transistor	BC 178 B		* *	
Q 8	Transistor	BC 109 C		* *	
Q 9	Transistor	BC 109 C		* *	
Q 10	Transistor	BC 108 B		* *	
Q 11	Transistor	BC 108 B		* *	
R 1	Resistor	carbon film	1 M	* *	
R 2	Resistor	carbon film	56 k	* *	
R 3	Resistor	carbon film	5.6 k	* *	
R 4	Resistor	carbon film	2.7 k	* *	
R 5	Resistor	carbon film	270	* *	
R 6	Resistor	carbon film	5.6 k	* *	
R 7	Resistor	carbon film	1.8 k	* *	
R 8	Resistor	carbon film	10 k	* *	
R 9	Resistor	carbon film	10 k	* *	
R 10	Resistor	carbon film	5.6 k	* *	
R 11	Resistor	carbon film	10 k	* *	
R 12	Resistor	carbon film	1.8 k	* *	
R 13	Resistor	carbon film	470 k	* *	
R 14	Resistor	carbon film	220 k	* *	
R 15	Resistor	carbon film	10 k	* *	
R 16	Resistor	carbon film	100	* *	
R 17	Resistor	carbon film	2.7 k	* *	
R 18	Resistor	carbon film	39 k	* *	
R 19	Resistor	carbon film	3.3 k - 1% - 0.33W	* *	
R 20	Resistor	carbon film	4.7 k	* *	
R 21	Resistor	carbon film	1.8 k	* *	
R 22	Resistor	carbon film	2.2 M	* *	
R 23	Resistor	carbon film	1 M	* *	
R 24	Resistor	carbon film	15 k	* *	
R 25	Resistor	carbon film	15 k	* *	

			Unspecified carbon film resistors: 1/8 W – 5 %	** Commercial types
IDENTIFICATION	PART NAME	TYPE / REMARKS	SPECIFICATIONS	ORDER NUMBER
R 26	Resistor	carbon film	15 k	* *
R 27	Resistor	carbon film	8.2 k	* *
R 28	Resistor	carbon film	33 k	* *
R 29	Resistor	carbon film	8.2 k	* *
R 30	Resistor	carbon film	120 k	* *
R 31	Resistor	carbon film	47 k	* *
R 32	Resistor	carbon film	2.7 k	* *
R 33	Resistor	carbon film	1 k	* *
R 34	Resistor	carbon film	33	* *
R 35	Resistor	carbon film	47	* *
R 36	Resistor	carbon film	15 k	* *
R 37	Resistor	carbon film	270 k	* *
R 38	Resistor	carbon film	220 k	* *
R 39	Resistor	carbon film	270 k	* *
R 40	Resistor	carbon film	15 k	* *
R 41	Resistor	carbon film	180 k	* *
R 42	Resistor	carbon film	27 k	* *
R 43	Resistor	carbon film	6.8 k	* *
R 44	Resistor	carbon film	15 k	* *
R 45	Resistor	carbon film	100 k	* *
R 46	Resistor	carbon film	3.3 k	* *
R 47	Resistor	carbon film	3.3 k	* *
R 48	Resistor	carbon film	1 M	* *
R 49	Resistor	carbon film	2.7 k	* *

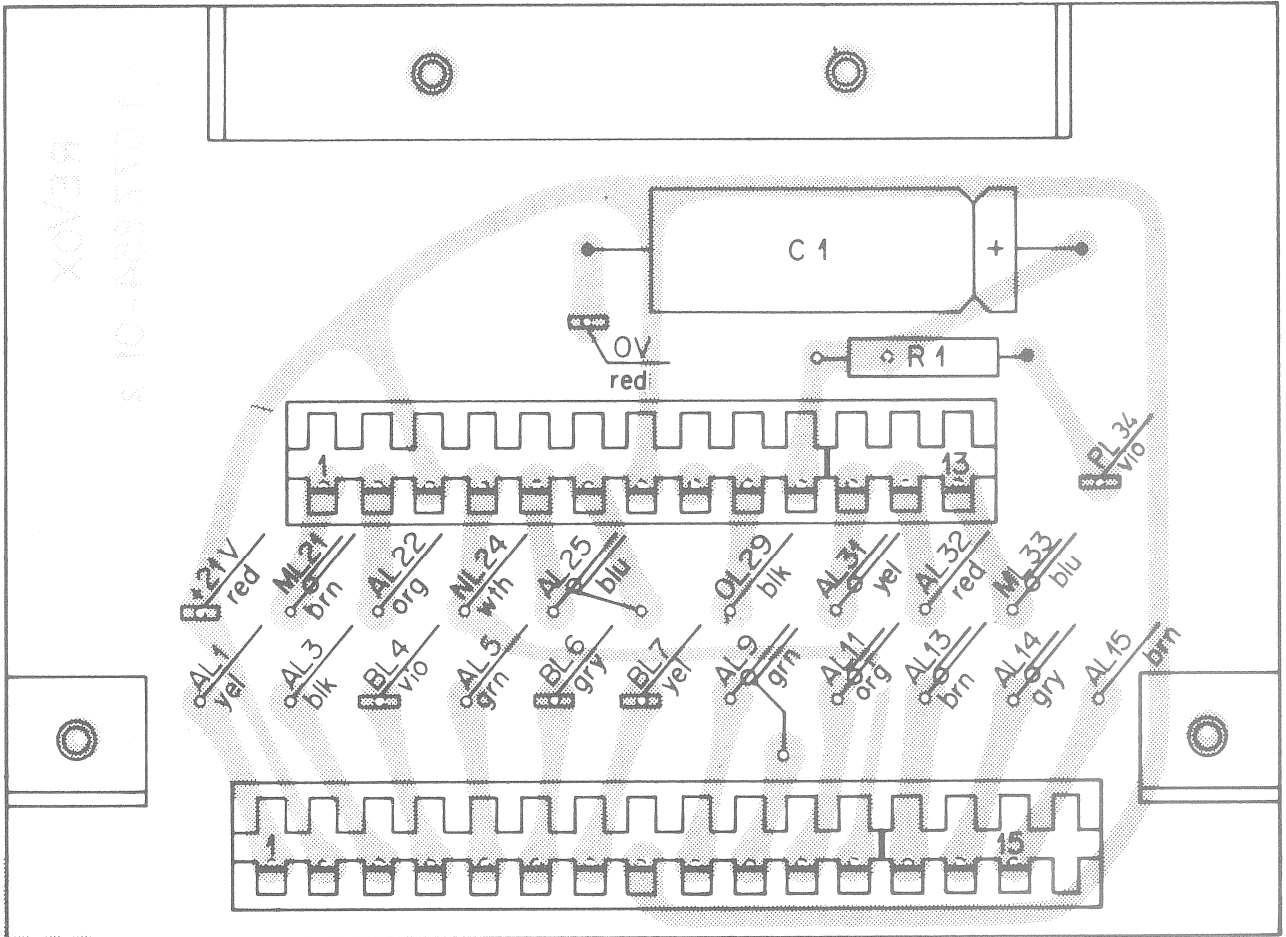

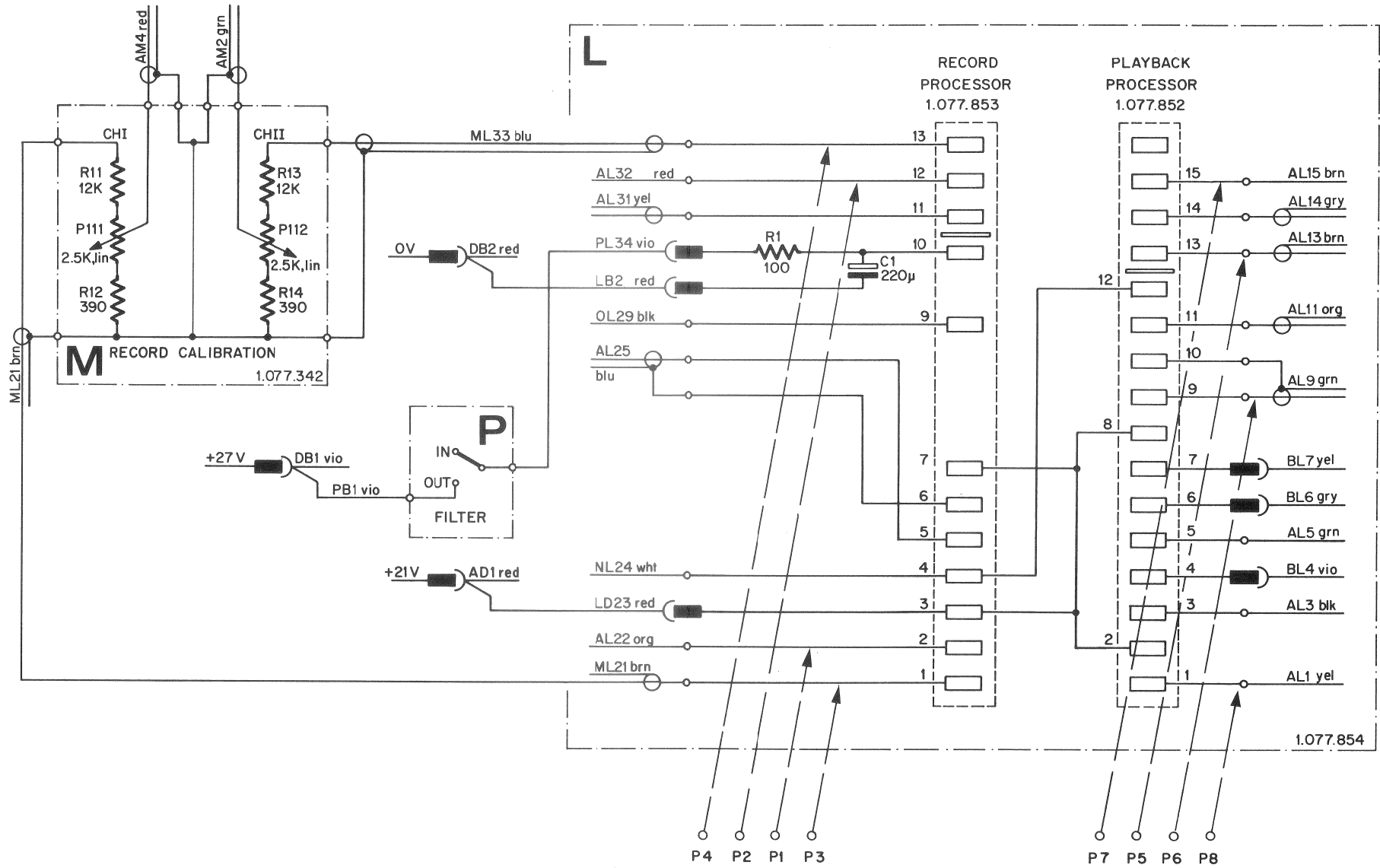

Interconnection 1.077.854

Unspecified carbon film resistors:
1/8 W – 5 %

**
Commercial types

IDENTIFI- CATION	PART NAME	TYPE / REMARKS	SPECIFICATIONS	ORDER NUMBER
	Interconnection 1.077.854	assembled		1.077.854
	Connector	for 1.077.853		1.012.134
	Connector	for 1.077.852		1.012.166
	Coding Piece	2 pieces		1.077.435.-10
	Flat-Connector	6 pieces		54.02.0320
C1	Capacitor	elektrolytic		* *
R1	Resistor	carbon film	100 – 5% – 0.33 W	* *

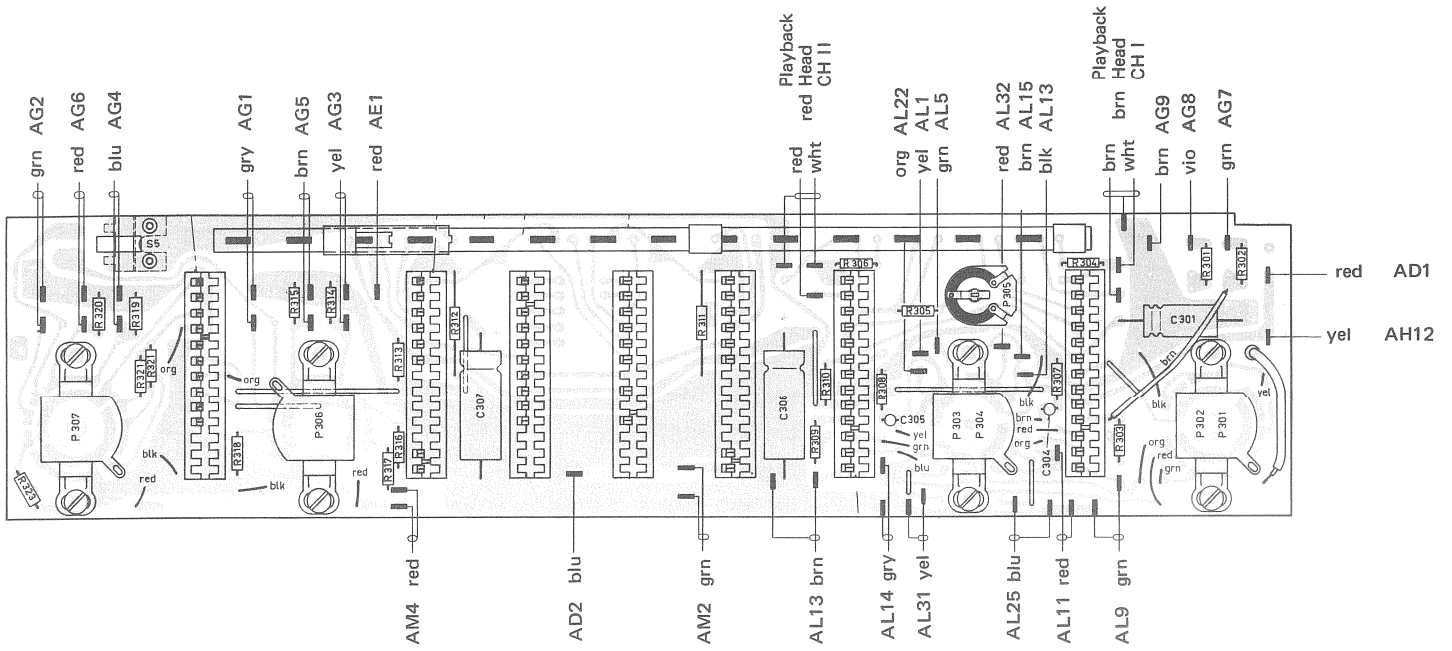

Switch Board
Part Side 1.077.426

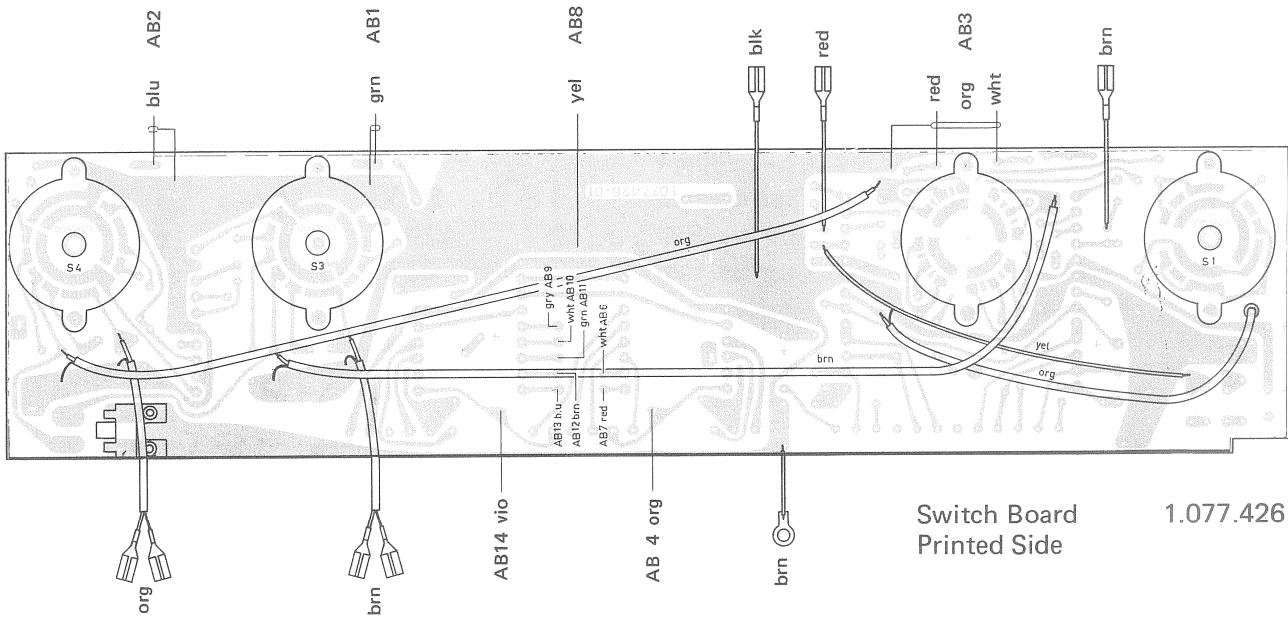

Switch Board
Printed Side 1.077.426

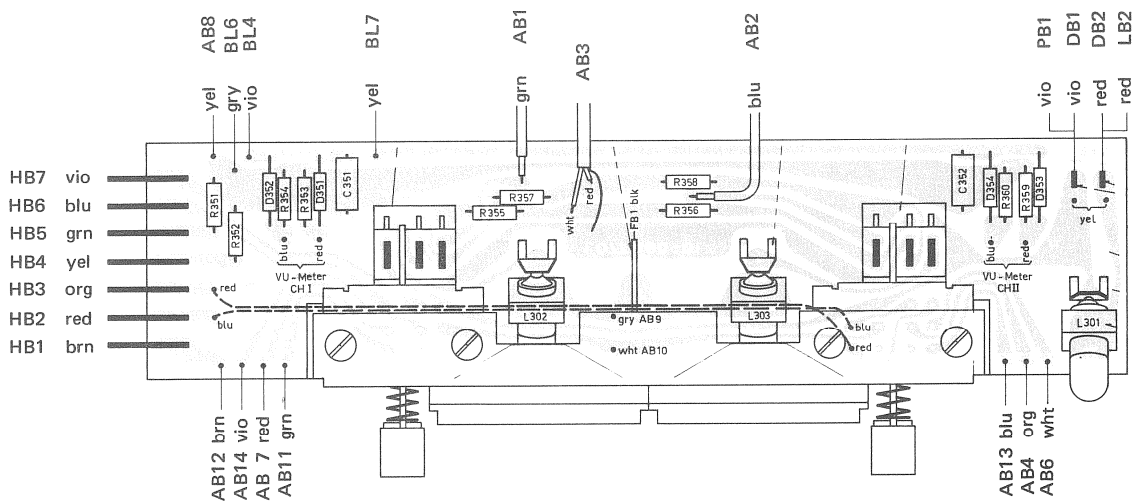

VU-Meter Board 1.077.468

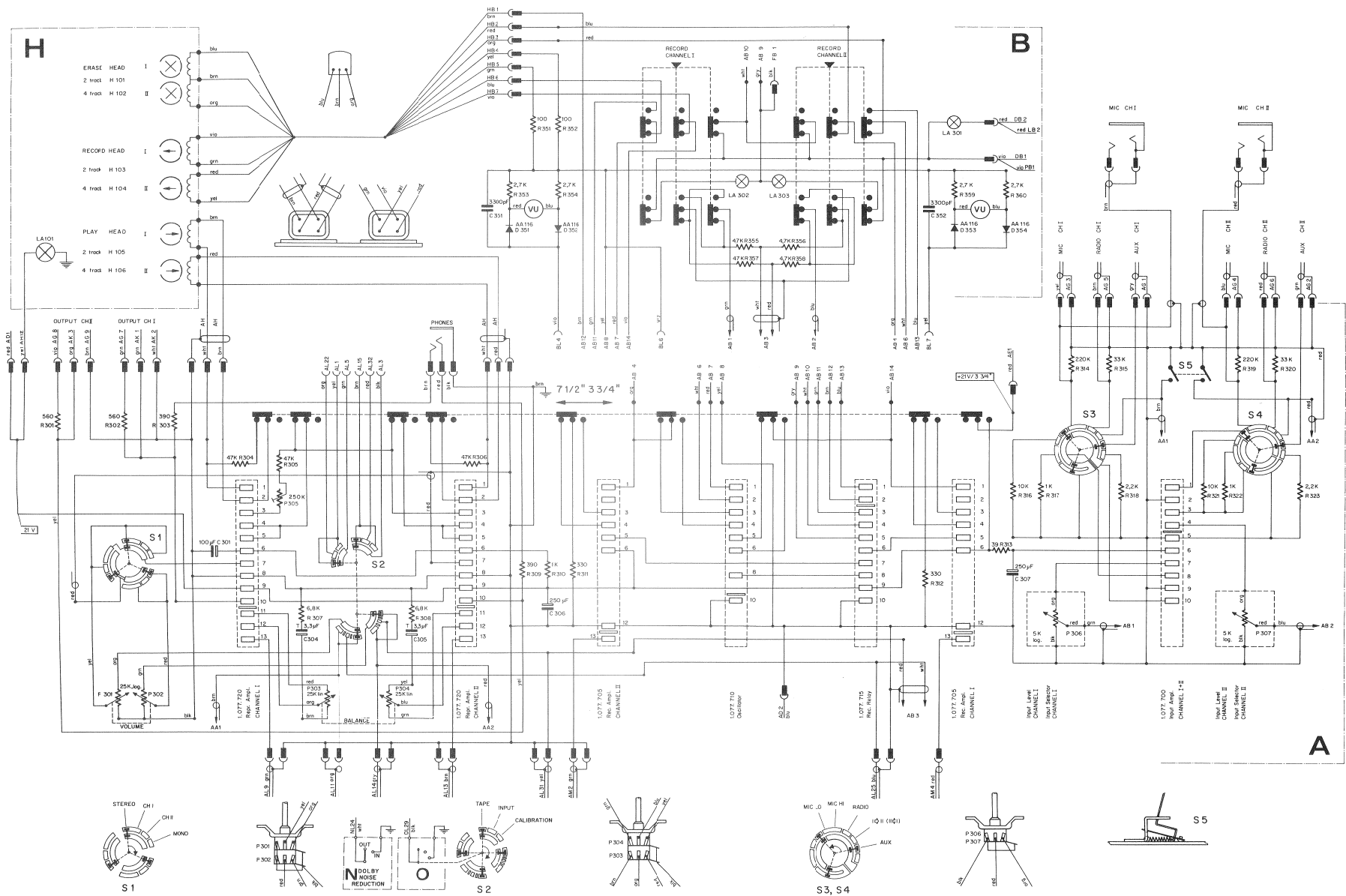

Switch Board 1.077.426

VU-Meter Board 1.077.468

			Unspezifiziert carbon film resistors: 1/8 W – 5 %	** Commercial types
IDENTI- FICATION	PART NAME	TYPE / REMARKS	SPECIFICATIONS	ORDER NUMBER
	VU-Meter Board	assembled		1.077.468
	VU-Meter	2 pieces		1.077.470-02
L 301 – L 303	Lamp Socket			1.077.480-02
L 301	Spring Contact			1.077.480-03
L 302, L 303	Spring Contact			1.077.480-04
L 301 – L 303	Lamp		36 V – 50 mA	51.02.0104
D 351	Ge – Diode	AA 116		* *
D 352	Ge – Diode	AA 116		* *
D 353	Ge – Diode	AA 116		* *
D 354	Ge – Diode	AA 116		* *
R 351	Resistor	carbon film	100	* *
R 352	Resistor	carbon film	100	* *
R 353	Resistor	carbon film	2.7 k	* *
R 354	Resistor	carbon film	2.7 k	* *
R 355	Resistor	carbon film	4.7 k	* *
R 356	Resistor	carbon film	4.7 k	* *
R 357	Resistor	carbon film	4.7 k	* *
R 358	Resistor	carbon film	4.7 k	* *
R 359	Resistor	carbon film	2.7 k	* *
R 360	Resistor	carbon film	2.7 k	* *
C 351	Capacitor	polyester	3300 pF – 400 V	* *
C 352	Capacitor	polyester	3300 pF – 400 V	* *

			Unspecified carbon film resistors: 1/8 W – 5 %	** Commercial types
IDENTIFICATION	PART NAME	TYPE / REMARKS	SPECIFICATIONS	ORDER NUMBER
	Switch Board	assembled		1.077.426
	Connector	1 piece (for 1.077.700)		1.077.435-05
	Connector	2 pieces (for 1.077.705)		1.077.435-03
	Connector	1 piece (for 1.077.715)		1.077.435-06
	Connector	1 piece (for 1.077.710)		1.077.435-04
	Connector	2 pieces (for 1.077.720)		1.077.435-02
	Coding Piece	7 pieces		1.077.435-10
	Switch Slide			1.077.435-07
S 1	Circuit Board Switch, 4/9	Playback mode switch, assembled		1.011.400
S 2	Circuit Board Switch, 3/10	Before/After-tape switch, assembled		1.011.300
S 3	Circuit Board Switch, 5/8	Input selector, assembled		1.011.500
S 4	Circuit Board Switch, 5/8	Input selector, assembled		1.011.500
S 5	Playback Cut-Off Switch	assembled		1.077.437
P 301	Potentiometer	Volume, assembled		1.077.430-09
P 302	Potentiometer	Volume, assembled		1.077.430-09
P 303	Potentiometer	Balance, assembled		1.077.430-08
P 304	Potentiometer	Balance, assembled		1.077.430-08
P 305	Trim-Potentiometer	Ruwido S 76 K	250 k – 20% – 0.15W	* *
P 306	Potentiometer	Input Level, assembled		1.077.430-07
P 307	Potentiometer	Input Level, assembled		1.077.430-07
C 301	Capacitor	elektrolytic	100 μ F – 25 V	* *
C 304	Capacitor	tantalum	3.3 μ F – 15 V	* *
C 305	Capacitor	tantalum	3.3 μ F – 15 V	* *
C 306	Capacitor	electrolytic	250 μ F – 25 V	* *
C 307	Capacitor	electrolytic	250 μ F – 25 V	* *

				Unspecified carbon film resistors: 1/8W – 5 %	** Commercial types
IDENTIFICATION	PART NAME	TYPE / REMARKS	SPECIFICATIONS	ORDER NUMBER	
R 301	Resistor	carbon film	560	* *	
R 302	Resistor	carbon film	560	* *	
R 303	Resistor	carbon film	390	* *	
R 304	Resistor	carbon film	47 k	* *	
R 305	Resistor	carbon film	47 k	* *	
R 306	Resistor	carbon film	47 k	* *	
R 307	Resistor	carbon film	6.8 k	* *	
R 308	Resistor	carbon film	6.8 k	* *	
R 309	Resistor	carbon film	390	* *	
R 310	Resistor	carbon film	1 k	* *	
R 311	Resistor	carbon film	330	* *	
R 312	Resistor	carbon film	330	* *	
R 313	Resistor	carbon film	39	* *	
R 314	Resistor	carbon film	220 k	* *	
R 315	Resistor	carbon film	33 k	* *	
R 316	Resistor	carbon film	10 k	* *	
R 317	Resistor	carbon film	1 k	* *	
R 318	Resistor	carbon film	2.2 k	* *	
R 319	Resistor	carbon film	220 k	* *	
R 320	Resistor	carbon film	33 k	* *	
R 321	Resistor	carbon film	10 k	* *	
R 322	Resistor	carbon film	1 k	* *	
R 323	Resistor	carbon film	2.2 k	* *	