

Zum Gebrauch dieses Handbuches

Das vorliegende Handbuch ist grob in sechs Abschnitte unterteilt:

DEUTSCH	Inhaltsverzeichnis und die Kapitel 1 bis 4 des deutschen Textes
ENGLISH	Inhaltsverzeichnis und die Kapitel 1 bis 4 des englischen Textes
Kapitel 5	Schemata
Kapitel 6	Ersatzteil-Liste
Kapitel 7	Technische Daten

How to use this manual

This manual is roughly divided into six sections:

DEUTSCH	Table of contents and chapter 1 to 4 in german language
ENGLISH	Table of contents and chapter 1 to 4 in english language
CHAPTER 5	Schematics
CHAPTER 6	Spare parts list
CHAPTER 7	Technical specifications

Subject to change  
Prepared and edited by  
STUDER REVOX  
TECHNICAL DOCUMENTATION  
Althardstrasse 10  
CH-8105 Regensdorf-Zurich

Copyright by Willi Studer AG  
Printed in Switzerland  
Order no. 10.30.0281 (Ed. 0985)

**Behandlung von MOS-Bauteilen**

MOS-Bausteine sind besonders empfindlich auf elektrostatische Ladungen. Folgendes ist daher zu beachten:

1. Elektrostatisch empfindliche Bauteile werden in Schutzverpackungen gelagert und transportiert. Auf der Schutzverpackung wird untenstehende Etikette angebracht.

**Handling MOS components**

MOS components are extremely sensitive to static charges. Please observe therefore the following regulations:

1. Components sensitive to static charges are stored and shipped in protective packages. On the package you find the subsequent symbol.

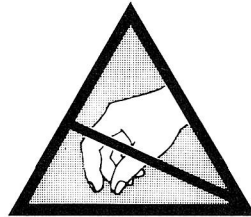
**Manipulation des composants MOS**

Les composants MOS sont extrêmement sensibles à l'électricité statique. Veuillez donc suivre les conseils suivants:

1. Les composants sensibles à l'électricité statique sont stockés et transportés dans des emballages protecteurs. Sur ces emballages est représenté le symbole suivant:

2. Jeglicher Kontakt der Elementanschlüsse mit Kunststoffütten und -folien aus Styropor oder ähnlichen elektrostatisch aufladbaren Materialien ist unter allen Umständen zu vermeiden.

3. Anschlüsse nicht berühren oder nur dann, wenn das Handgelenk geerdet ist.

4. Als Arbeitsunterlage eine geerdete, leitende Matte verwenden.

5. Printkarten nicht unter Spannung herausziehen oder einstecken.

2. Avoid any contact of connector pins with foam packages and -foils made of styropor or similar chargeable package material.

3. Don't touch the connector pins when your wrist is not grounded with a conducting wristlet.

4. Use a grounded conducting mat when working with sensitive components.

5. Never plug or unplug PCBs containing sensitive components when the machine is switched on.

2. Evitez tout contact entre les broches des circuits et les sacs en plastiques, feuilles de styropor ou tout autre matériau susceptible de porter une charge électrostatique.

3. Ne touchez pas les broches des circuits si votre poignet n'est pas relié à la terre par un bracet conducteur.

4. Utilisez un tapis conducteur relié à la terre quand vous travaillez avec des composants sensibles.

5. Ne jamais enficher ou retirer des circuits imprimés contenant des composants sensibles si l'appareil est sous tension.



<b>INHALTSVERZEICHNIS</b>	<b>Seite</b>
<b>1. ALLGEMEINES</b>	
1.1 Uebersicht der Bedienungselemente	1/1
1.1.1 Allgemeine Bedienungselemente	1/1
1.1.2 Spezielle Bedienungselemente	1/2
1.1.3 Anschluesse an der Rueckseite	1/3
<b>2. AUSBAU DER BAUGRUPPEN</b>	
2.1 Entfernen des oberen Deckbleches	2/1
2.2 Entfernen der Seitenwaende	2/1
2.3 Ausbau der einzelnen Printkarten	2/1
2.4 Laufwerk ausbauen	2/1
2.4.1 Laufwerk Nr. 1.769.110	2/1
2.4.2 Laufwerk Nr. 1.769.112	2/2
2.5 Display ausbauen	2/2
2.6 Netztransformator ausbauen	2/2
2.7 Schubladenmotor ausbauen	2/2
2.8 Bedienungseinheit ausbauen	2/3
2.9 Fuehrungsstangen ausbauen	2/3
2.10 CD-Laufwerk-Austausch	2/3
2.11 Zusammenbau	2/3
<b>3. SCHALTUNGSBESCHREIBUNGEN</b>	
3.1 SERVO 1 PCB 1.769.310	3/1
3.1.1 Stabilisierung der Speisespannungen	3/1
3.1.2 Schubladenpositionsdetektor	3/1
3.1.3 Fokus- Regelkreis	3/2
3.1.4 Regelkreis fuer den Disc- Motor	3/2
3.2 Mikroprozessor PCB 1.769.320	3/3
3.2.1 Mikroprozessorsystem	3/3
3.2.2 Schubladenmotor- Steuerung	3/4
3.3 SERVO- 2 PCP 1.769.330	3/4
3.3.1 Radialregelung	3/4
3.3.2 Eigentliche Radialregelung	3/4
3.3.3 Automatic Gain Control- (AGC-) Schaltung	3/5
3.3.4 Offset- Kontrollschaltung	3/5
3.3.5 Spurdetektorschaltung	3/6
3.4 Preamplifier and Laser PCB 1.769.100.35	3/6
3.4.1 Laseransteuerung	3/6
3.4.2 Regelsignale fuer die Fokus- und Radialregelung	3/6
3.4.3 HF- Signalverstaerker	3/6
3.5 Decoder PCB 1.769.300	3/6
3.5.1 Digitale Signalverarbeitung	3/7
3.5.2 Digitaler Sinusgenerator	3/7
3.5.3 HFL- und DO- Detektor	3/7
3.6 DAC PCB 1.769.280	3/7
3.6.1 Digitale Filterung (Oversampling) und D/A- Wandlung	3/7
3.6.2 PegelEinstellung und Kopfhoererverstaerker	3/8

<b>4.</b>	<b>MESSPUNKTE, EINSTELLUNGEN AM B225</b>	
4.1	Messpunkte am B225	4/1
4.1.1	Testpunkte auf Servo 1 PCB 1.769.310	4/1
4.1.2	Testpunkte auf Servo 2 PCB 1.769.330	4/3
4.1.3	Testpunkte auf Mikroprozessor PCB 1.769.320	4/4
4.1.4	Testpunkte auf Decoder PCB 1.769.300	4/6
4.1.5	Testpunkte auf DAC- PCB 1.769.280	4/8
4.2	Einstellungen am CD- Player B225	4/9
4.2.1	Hilfsmittel	4/9
4.2.2	Laufwerkabgleich, Allgemeines	4/9
4.2.3	Laserstrom einstellen	4/9
4.2.4	Symmetrie einstellen	4/10
4.2.5	Fokus- Gain einstellen	4/10
4.2.6	Kontrolle der Winkeleinstellung	4/11
4.2.7	DC- Komponente des Fokus- Signals einstellen	4/12
4.2.8	Spule L1 einstellen	4/12
4.3	Messen der Audio- Daten	4/12
4.3.1	Hilfsmittel	4/12
4.3.2	Klirrfaktor	4/12
4.3.3	Ausgangspegel	4/12
4.3.4	Frequenzgang	4/13
4.3.5	Uebersprechen	4/13
4.3.6	Fremdspannungsabstand	4/13
4.3.7	Geraeuschnspannungsabstand	4/13
4.3.8	Phasenlinearitaet	4/13
4.4	Akustische Beurteilung mit CD- Testplatte	4/13
<b>5.</b>	<b>SCHEMASAMMLUNG</b>	
<b>6.</b>	<b>ERSATZTEILLISTE</b>	
<b>7.</b>	<b>TECHNISCHER ANHANG</b>	
7.1	Technische Daten	7/1
7.2	Abmessungen	7/2

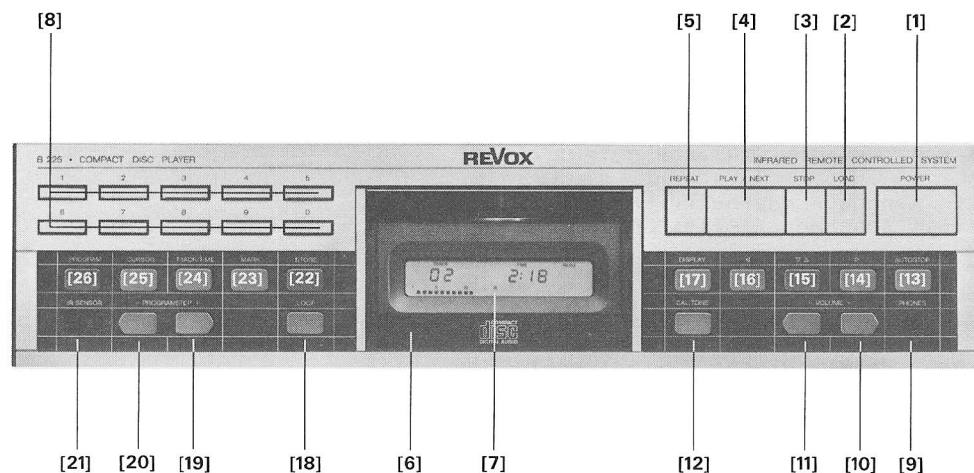
**1. ALLGEMEINES****1.1 Uebersicht der Bedienungselemente****1.1.1 Allgemeine Bedienungselemente**

- {1} POWER \* Mit dieser Taste kann das Geraet ein- und ausgeschaltet werden. Gewisse Teile (Bsp. der IR- Empfaenger) bleiben allerdings immer eingeschaltet (sog. Stand-By Betrieb).
- {2} LOAD Durch Betaetigen dieser Taste faehrt das Laufwerk {6} aus resp. ein.
- {3} STOP \* Mit dieser Taste kann der Abspielvorgang unterbrochen werden. Dadurch wird der Laser-Abtaster wieder in die Anfangsposition zurueck gesteuert und falls das Geraet im Program-Mode war, das Programm abgebrochen. Die Position des Laser- Abtasters kann nach Druetzen der Taste STOP nicht reproduziert werden. Falls dies gewünscht wird, siehe Taste **VA** (PAUSE).
- {4} PLAY/NEXT Abspieltaste mit folgenden Funktionen:  
Betaetigen nach LOAD {2}, die CD beginnt zu drehen, das Inhaltsverzeichnis wird ausgelesen und die Platte wird ab dem ersten Stueck (TRACK) abgespielt. Nochmaliges Druetzen, das naechste Stueck (TRACK) wird angewaehlt. Betaetigen nach Druetzen einer der Tasten {8}, direkte Anwahl des (X-ten) Stueckes. Betaetigen nach Druetzen der Taste PROGRAM {26} der Program-Mode wird aktiviert. Druetzen waehrend einem aktiven Programm, der naechste Programm-Schritt wird angewaehlt.
- {5} REPEAT Druetzen dieser Taste bewirkt sofortiges Repeating des gerade laufenden Stueckes. Ist das Geraet auf Stopp, so wird das erste Stueck der CD abgespielt. Ist das Geraet im Program-Mode, wird der laufende Programm-Schritt wiederholt.
- {6} (Laufwerk) Laufwerkeinschub mit CD-Laufwerk und Fluessigkristall-Anzeige, welches durch Druetzen der Taste LOAD {2} aus- / eingefahren werden kann.
- {7} (Anzeige) Multifunktioneller LC-Display. Diese Anzeige informiert ueber saemtliche Betriebszustaende des Geraetes und ueber den Inhalt der eingelegten CD.
- {8} (Tasten 0-9) Zahlen-Eingabetasten. Sie koennen fuer die direkte Anwahl eines Stueckes (TRACK) in Verbindung mit der Taste PLAY/NEXT {4} oder zur Programmierung verwendet werden.

Mit den Tasten der oberen Reihe ({1} bis {8}), mit Ausnahme der Tasten REPEAT {5} und der Zahl taste 0 kann das Geraet eingeschaltet werden. Dabei startet es im dadurch vorgewaehlten Betriebsmodus.

### 1.1.2 Spezielle Bedienungselemente

Die Bedienungselemente im unteren Frontplattenteil koennen grob in zwei Funktionsgruppen unterteilt werden: Bedienungselemente fuer zusaetzliche Laufwerk- Funktionen und Bedienungselemente fuer die Programmierung.

#### **A Bedienungselemente fuer zusaetzliche Laufwerkfunktionen**

- {9} PHONES            Klinken-Buchse fuer Kopfhoerer 200 ... 600 Ohm.  
{10} VOLUME +        Mit dieser Taste kann der Kopfhoerer-Pegel wie auch der Pegel des Ausgangs VARIABLE OUTPUT erhoehrt werden.  
{11} VOLUME -        Mit dieser Taste kann der Kopfhoerer-Pegel wie auch der Pegel des Ausgangs VARIABLE OUTPUT abgeschwaecht werden.  
{12} CAL TONE \*      Kalibrierton-Taste, mit dieser Taste kann ein 1000 Hz- Kalibrierton auf die Ausgaenge geschaltet werden.  
Der 1000 Hz CAL TONE entspricht dem maximal moeglichen Ausgangspegel. Dieser Maximalpegel ist systembedingt und wird auch von kurzen Impulsen nicht ueberschritten.  
{13} AUTOSTOP        Druetzen dieser Taste bewirkt, dass der Abspielvorgang am Schluss des gerade laufenden Stueckes oder Programm-Schrittes unterbrochen wird. Dabei wird der Laser- Abtaster automatisch an den Anfang des naechsten Stueckes positioniert. Unwillkuerlich nach Druetzen der Taste PAUSE ▼▲ {15} wird das naechste Stueck abgespielt. Nach diesem wird wieder automatisch auf Pause geschaltet.  
{14} Taste ▶        Mit dieser Taste kann in einem Stueck jede Stelle gegen das Ende hin angefahren werden.  
{15} ▼▲ (Pause)\*    Mit dieser Taste kann der Abspielvorgang jederzeit unterbrochen werden.  
{16} Taste ◀        Mit dieser Taste kann in einem Stueck jede Stelle gegen den Anfang hin angefahren werden.  
{17} DISPLAY        Mit dieser Taste kann die Anzeige umgeschaltet werden. Im normalen Abspielmodus wird bei jedem Stueck die Zeit ab Anfang des Stuecks angezeigt. Durch Druetzen dieser Taste wird die gesamte Spielzeit von Anfang bis zum gerade gespielten Stueck angezeigt.

\* Diese Funktionen koennen auch in Programmen verwendet werden.

#### **B Tasten fuer die Programmierung**

- {18} LOOP \*        Mit dieser Taste kann der Befehl gegeben werden, die CD oder das Programm immer wieder abzuspielen, bis die Taste STOP {3} gedruetzt wird.  
{19} +            Diese Taste erlaubt waehrend dem Programmieren das "Aufwaerts- Blaettern" im Programm. Sie ist eine nuetzliche Hilfe wenn ein bestehendes Program abgeaendert werden soll.  
{20} -            Gleiche Funktion wie {19} jedoch abwaerts.  
{21} IR-SENSOR    Infrarot-Empfaengerfenster  
{22} STORE        Speicherladetaste, welche nach jeder Programm-Schritt- Eingabe gedruetzt werden muss. Dadurch wird automatisch der naechste Programmschritt auf der Anzeige angezeigt, und die entsprechenden Angaben koennen eingegeben werden.  
{23} MARK        Mit dieser Taste kann im Programmiervorgang waehrend ein Stueck abgehoeert wird eine Start- und Stopmarke gesetzt werden. Dadurch kann auch im Program-Mode jede beliebige Stelle programmiert werden.  
{24} TRACK/TIME    Mit dieser Taste kann die Anzeige waehrend dem Programmiervorgang von Stueck-(Track-) Eingabe auf Zeiteingabe (Min. und Sec.) geschaltet werden.

- {25} CURSOR Mit dem Cursor kann jede Stelle in der Anzeige angefahren und danach nach Bedarf editiert werden. **Achtung:** Ist die Eingabe auf Zeit (TIME) geschaltet, so muss um die Sekunden zu programmieren nach der Minuten-Eingabe mit dem Cursor weitergeschaltet werden.
- {26} PROGRAM Mit dieser Taste kann der Eingabemodus eingestellt werden. Wird nach erfolgter Programm-Eingabe die Taste PLAY/NEXT {4} gedrueckt, so startet das Geraet im Program-Mode. Falls nach dem Programmvorgang der CD-Player in der normalen Betriebsart gestartet wird, so muss vogaengig zur Taste PLAY/NEXT die Taste PROGRAM {26} nochmals gedrueckt werden.

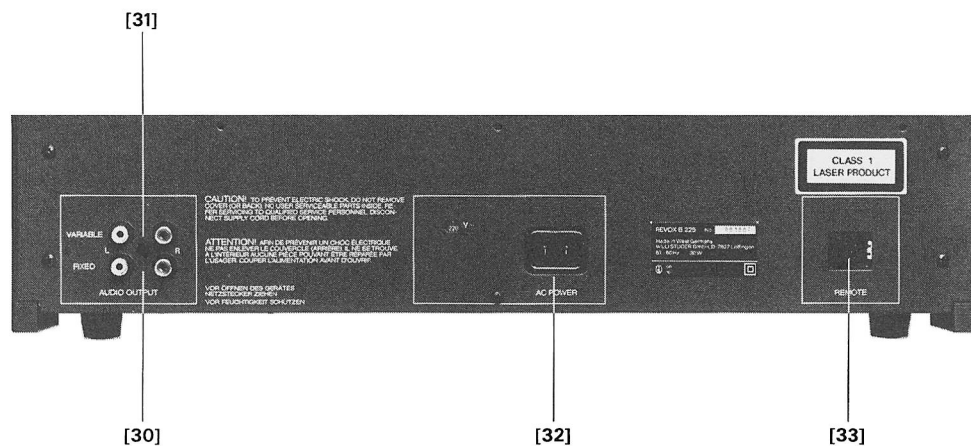

### 1.1.3 Anschlüsse an der Ruckseite

- {30} AUDIO OUTPUT FIXED, Ausgang fuer einen Verstaerker bei welchem der Eingang an den Pegel des CD-Players angepasst werden kann (der Verstaerker REVOX B251 ist ab Werk optimal angepasst).
- {31} AUDIO OUTPUT VARIABLE, an diesen Ausgang koennen Aktivboxen oder eine Endstufe etc. direkt angeschlossen werden. Die Lautstaerke kann mit den beiden Tasten VOLUME + und - an der Frontplatte des CD-Players eingestellt werden.
- {32} AC POWER, Netzanschluss (daneben ist die Spannungseinstellung kontrollierbar).
- {33} REMOTE, ueber diesen Anschluss kann a.) der IR-Empfänger unterdrueckt und b.) eine Kabelfernbedienung angeschlossen werden.

## 2. AUSBAU DER BAUGRUPPEN

### Achtung:

Bevor Gehäuseteile entfernt werden, ist das Gerät vom Netz zu trennen. Für einige Arbeiten ist es notwendig, die Schublade ein- resp. auszufahren. Dies kann von Hand gemacht werden, das Gerät nimmt dabei keinen Schaden.

### 2.1 Entfernen des oberen Deckbleches

- An der Geräterückseite fünf Schrauben {A} lösen.
- Deckblech nach hinten wegziehen.

### 2.2 Entfernen der Seitenwände

- An den Seitenwänden je zwei Schrauben lösen, die Seitenwände können weggenommen werden.

### 2.3 Ausbau der einzelnen Printkarten

Die Printkarten sind nach Entfernen des oberen Abdeckblechs (Kap. 2.1) zugänglich.

Die Printkarten 1.769.280 (DAC PCB), 1.769.300 (DECODER PCB) und 1.769.330 (SERVO 2 PCB) können aus dem Verbindungsprint gezogen werden, wenn die Fixierschrauben {B} gelöst werden.

Um den Print 1.769.320 (MICROPROCESSOR PCB) auszubauen, müssen zuerst vier Steckverbindungen getrennt werden. Danach Schraube {B} lösen und den Print nach hinten aus dem Gerät ziehen.

Der SERVO 1 PCB 1.769.315 ist über das Kühlblech der Spannungsregler mit dem Chassis verbunden. Zuerst müssen sämtliche Steckverbindungen welche auf diesen Print führen ausgezogen werden. Um die drei Befestigungsschrauben des Kühlbleches zugänglich zu machen, muss die Schublade ganz hinausgestossen werden. Danach können die drei Schrauben {C} gelöst und der Print nach hinten herausgezogen werden.

- Fig. 2.3

### 2.4 Laufwerk ausbauen

#### 2.4.1 Laufwerk Nr. 1.769.110

(Geräte Nr. bis 9523, sowie von 10236 bis 11187)

- Oberes Deckblech entfernen (Kap. 2.1)
- Schublade ein wenig herausstossen, und das Gerät auf die Oberseite legen.
- Die Schublade nun soweit herausziehen, bis die Schrauben {D} zugänglich sind.
- Schrauben {D} lösen und das Gerät wieder in normaler Betriebslage auf den Tisch stellen (Achtung, das Laufwerk muss dabei mit der Hand in der Schublade gehalten werden).
- Die Schublade ganz herausziehen und das Laufwerk vorsichtig anheben.
- Die sechs Steckverbindungen (siehe Fig. 2.5) ausziehen.
- Das Laufwerk kann nun aus der Schublade gehoben werden.

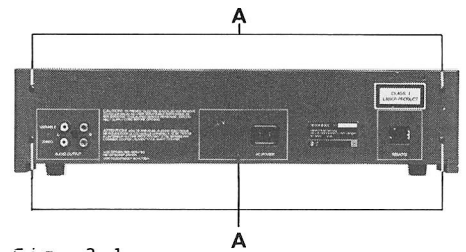

Fig. 2.1

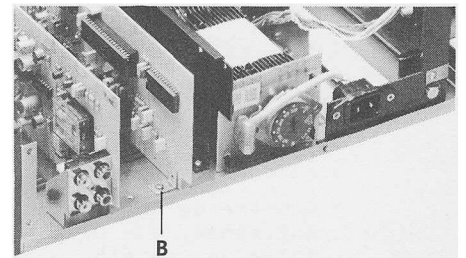

Fig. 2.2

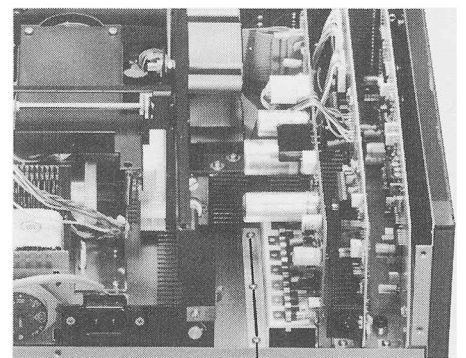

Fig. 2.3

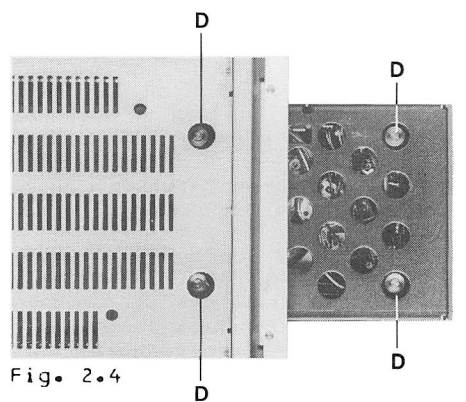

Fig. 2.4

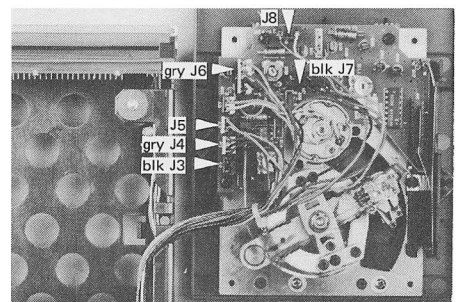

Fig. 2.5

**2.4.2** Laufwerk Nr. 1.769.112

(Geraete Nr. 9524 bis 10235, sowie ab 11188)

- Ausbauen siehe 2.4.1
- Anstelle der sechs Steckverbindungen sind nur deren vier zu loesen (siehe Fig. 2.6).

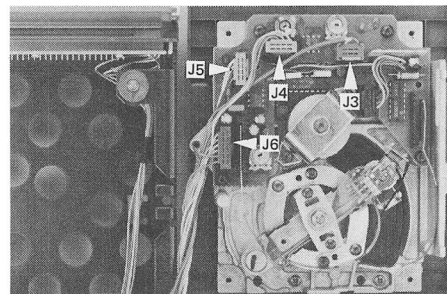

Fig. 2.6

**2.5** Display ausbauen

- Laufwerk ausfahren und auf der Seite je zwei Schrauben {E} loesen.
- Kabelbride {F} loesen und den Stecker des Kabelbundes ausziehen. Das Display kann nun herausgehoben werden, indem der Kabelbund vorsichtig unter dem Laufwerk durchgezogen wird.

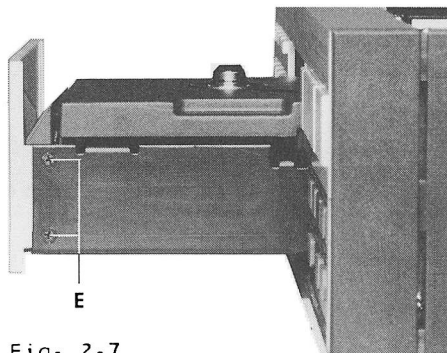

Fig. 2.7

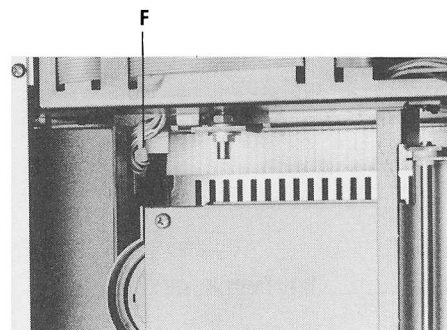

Fig. 2.8

**2.6** Netztransformator ausbauen

- Oberes Deckblech ausbauen (siehe Kap. 2.1).
- Von der Unterseite her vier Schrauben {G} loesen.
- Die Steckverbindungen des Netztransformators zum Servo 1 Print 1.769.315 auftrennen, Apparatestecker durch Loesen der beiden Schrauben ausbauen und Schraube {H} (schwarzes Kabel, Loetoese) loesen.
- Der Transformator kann herausgenommen werden.

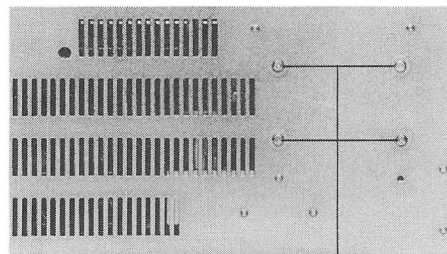

Fig. 2.9

**2.7** Schubladenmotor ausbauen

- Oberes Deckblech ausbauen (siehe Kap. 2.1).
- Netztransformator ausbauen (siehe Kap. 2.6).
- Drei Schrauben {H} von oben loesen, Feder {I} aushaengen, die Steckverbindungen, welche vom Motor zum Mikroprozessor PCB 1.769.320 fuehren trennen, und den Motor vorsichtig herausnehmen.

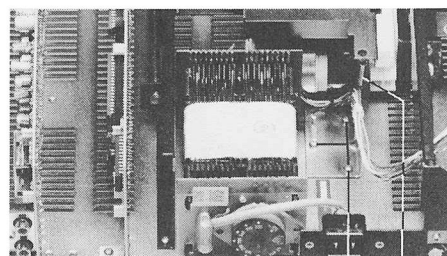

Fig. 2.10

H I



**2.8 ----- Bedienungseinheit ausbauen**

- Oberes Deckblech und Seitenwaende ausbauen (siehe Kap. 2.1 und 2.2).
- Ober- und unterhalb der Bedienungseinheit je vier Schrauben {K} loesen.
- Die Bedienungseinheit vorsichtig vom Chassis wegziehen und die Steckverbindungen auftrennen.

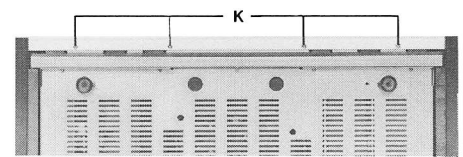
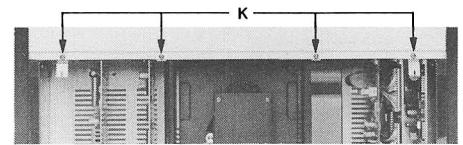

Fig. 2.11

**2.9 ----- Fuehrungsstangen ausbauen**

- Oberes Deckblech ausbauen (siehe Kap. 2.1).
- Den inneren Seegering {L} loesen und die Stange kann nach hinten aus dem Geraet gezogen werden.

**Achtung:** Der kleine O- Ring, welcher den Endanschlag der Schublade daempft, darf nicht verloren gehen.

- Vor dem Wiedereinbau der Fuehrungsstangen, sind diese mit Spezialfett ISOFLEX TOPAS NB52 leicht einzufetten.

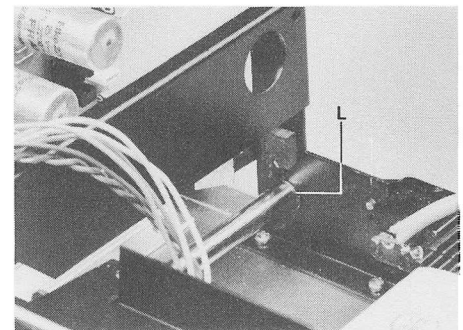

Fig. 2.12

**2.10 ----- CD-Laufwerk-Austausch**

- Laufwerk ausbauen (Kap. 2.4)
- Fruhere Laufwerke sind mit einem Electronic-Print ausgeruestet, der nicht mehr verfuegbar ist. Der neue Print ist mit anderen Anschluss-Steckern bestueckt, sodass die Anschluss-Litzen der fruheren CONNECTION PCB 1.769.390-00/-81 mit neuen Anschluss-Steckern (dem neuen Laufwerk beige-packt) versehen werden muessen. Dazu werden die Litzen moeglichst nahe der alten Stecker abgeschnitten. Die freien Litzenenden werden, ohne die Isolation zu entfernen, laut nachfolgender Tabelle in die neuen Stecker eingesteckt (Pin 1 ist auf dem Stecker bezeichnet), und diese anschliessend bis zum Einrasten zusammengedruickt. Nach einstecken der Stecker auf dem Laufwerkprint, kann das neue Laufwerk wieder montiert werden.

Farbe	1.769.110	1.769.112
blk	J6/1	J5/1
brn	J6/2	J5/2
red	J6/3	J5/3
gry	J6/4	J5/4
blk	J7/1	J4/1
brn	J7/2	J4/2
red	J7/3	J4/3
gry	J7/4	J4/4
yel	J5/1	J6/1
grn	J5/2	J6/2
blk	J4/1	J6/3
brn	J4/2	J6/4
blk	J3/1	J6/5
brn	J3/2	J6/6
wht	J8/1	J3/1
n.c.	J8/2	J3/2
scr.	J8/3	J3/3

**2.11 ----- Zusammenbau**

Der Zusammenbau des Geraetes erfolgt in umgekehrter Reihenfolge. Der Kabelbund in der Schublade muss unbedingt mit einer Kabelbride gemaess Fig. 2.8 befestigt werden.



**3. SCHALTUNGSBESCHREIBUNGEN**

**3.1 SERVO 1 PCB 1.769.310/315**

Auf dem Servo 1 Print sind folgende Schaltungen untergebracht:

- Stabilisierung der Speisespannungen
- Schubladenpositionsdetektor
- Fokusregelkreis
- Regelkreis fuer den Disc- Motor
- Beim Servo 1 PCB 1.769.315 sind die Bauteile (Q 13, C 31, R 60 und R 61) im Gegensatz zum 1.769.310 nicht bestueckt.
- Der Umbau von 1.769.310 auf 1.769.315 wird generell empfohlen; zu diesem Zweck braucht lediglich der Kondensator C 31 ausgeloetet zu werden (Fig. 3.3).

**3.1.1 Stabilisierung der Speisespannungen**

Saemtliche Speisespannungen werden ueber Spannungsregler (IC 4 ... IC 9, LM317/LM337) stabilisiert. Die +5V- Speisung (+5V- STBY) ist dauernd vorhanden. Sie speist das Mikroprozessorsystem und den IR- Empfaenger, auch wenn das Geraet ausgeschaltet ist (Stand By). Die restlichen Speisespannungen werden mit dem Signal PS-OFF vom Mikroprozessor ein- resp. ausgeschaltet. Wird das Geraet ausgeschaltet, so wird PS- OFF "H" (+5V) und die Transistoren Q9 und Q10 werden leitend (gesaettigt). Dadurch werden die +5V- und +12V- Speisungen auf die Restspannung von 1,3V geschaltet. Die -7V- Speisung wird ueber die Schaltung R38, R39 und Q8, die -12V- Speisung ueber R52, R54 und Q11 und die -17V- Speisung ueber R51, R53, und Q12 abgeschaltet. Auf diese Art wird verhindert, dass die positiven Speisespannungen negativ werden koennen. Ueber die Dioden D15, D16 und D17 und die Kondensatoren C29 und C30 wird die Spannung verdoppelt und auf den Spannungsregler IC9 fuer die -17V- Speisung gefuehrt. D18 dient als Schutz des Reglers vor zu hoher Laengsspannung.

**3.1.2 Schubladenpositionsdetektor**

Die beiden Gabel-Lichtschranken DLQ1 und DLQ2 (auf PCB 1.769.310) pruefen, ob die Schublade offen oder zu ist. Die entsprechenden Signale zeigen folgende Zustaende:

Position	DRA-POS-B	DRA-POS-F
geschlossen	L	L
in der Mitte	H	L
offen	H	H

L = 0V  
H = +5V

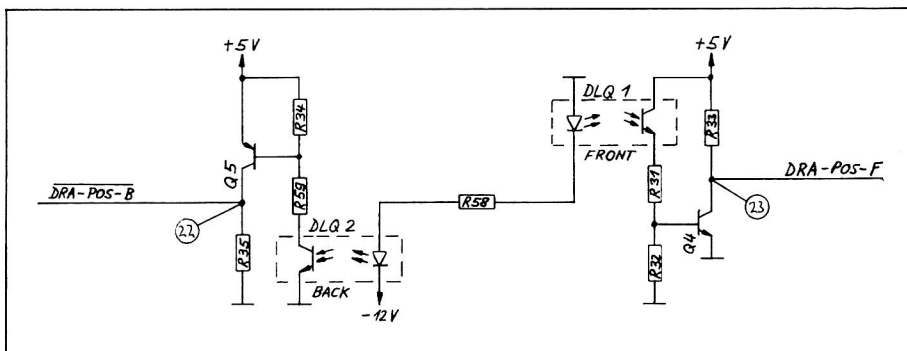

Fig. 3.1

**3.1.3 Fokus- Regelkreis**

Die Objektivlinse ist vertikal beweglich und aehnlich der Mechanik eines Lautsprechers aufgebaut. Die Linse wird magnetisch gesteuert. Die Spule bleibt stationaer, der Magnet wird bewegt. Das Fokus- Fehlersignal FOC-ERR wird zuerst verstaerkt ("Lead"-Verstaerker IC2a, R3, R12, R16, R17, C3, C4) und danach auf den Regelverstaerker ("Lag"- Verstaerker R1, R2, R5, R11, R15, R29, R30, C2, C12, IC2b, Q6, Q7 und die Impedanz der Objektivlinsenspule) gefuehrt. Im Stop- Mode wird der Regelkreis durch das Signal FOC-0 ueber Q1 unterbrochen (FOC-0 = H). Dadurch wird ueber den Endverstaerker (Q6 und Q7) keine unnoetige Energie verbraucht.

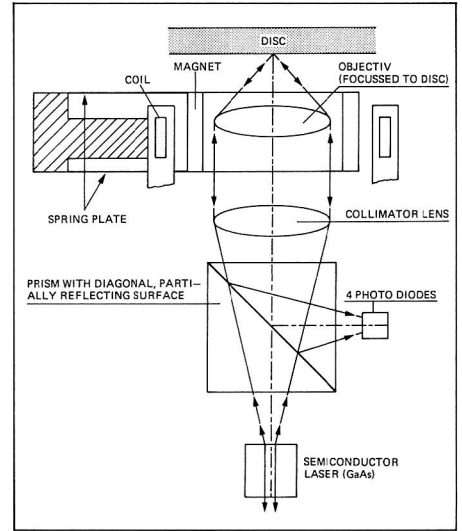

Fig. 3.2

Die Start-Up Schaltung (IC1, R6, R7) stellt die Fokussierung auf die reflektierende Schicht der Compact Disc ein. Dabei werden die Signale FC-1 und FC-2 alternierend auf "H" geschaltet. Dies bewirkt, dass die Objektivlinse sich abwechslungsweise nach oben resp. nach unten bewegt. Ist der Fokuspunkt gefunden, faellt das Signal FOC-NEG kurzfristig auf "L". Darauf gibt der Mikroprozessor den Fokusregelkreis frei (FOC-0 = H).

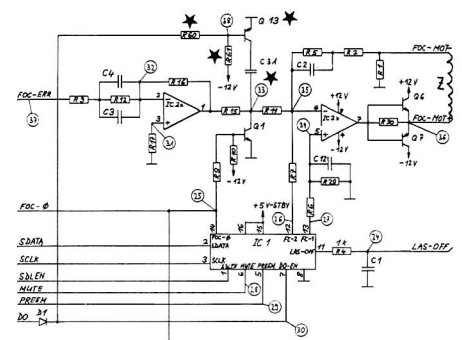

Fig. 3.3 \*Entfallen bei 1.769.315

**3.1.4 Regelkreis fuer den Disc- Motor**

Die Daten von der Compact Disc muessen so konstant wie moeglich der Schaltung fuer die digitale Signalaufbereitung zugefuehrt werden. Die Geschwindigkeit, mit welcher diese Daten (Bit) eintreffen, haengt von der Position des Laser- Abtasters ab (konstante Umfangsgeschwindigkeit zwischen 1,2 und 1,4 m/s). Liest der Laser- Abtaster in der Mitte der CD, so ist die Drehzahl entsprechend hoch, in der Naehة des Randes niedrig. Das Drehzahl- Korrektursignal MCES wird im Fehlerkorrektur- IC (SAA 7020 auf PCB 1.769.300) gebildet.

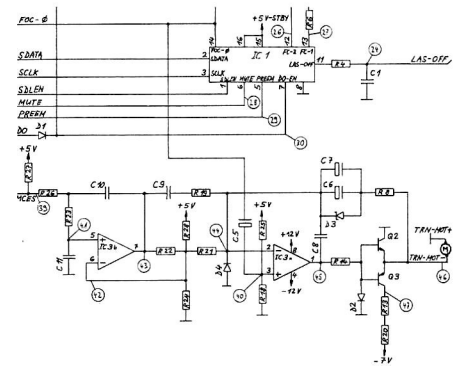

Fig. 3.4

Das MCES- Signal wird ueber das FOC-0- Signal ein- resp. ausgeschaltet (R15, R16, IC3b auf PCB 1.769.330). Zuerst wird das Signal ueber einen Tiefpass zweiter Ordnung gefiltert (R22, R23, R25, R26, R28, C10, C11, IC3b). Das "Lead- Netzwerk" wird durch C9, R19, R21, R24 und R28 gebildet, das "Lag- Netzwerk" durch IC3a, C6, C7, R8, Q2 und Q3. Sobald der Fokuspunkt gefunden ist, wird das Signal FOC-0 "LOW". Dadurch wird das MCES- Signal freigegeben. Gleichzeitig wird ueber C5 ein negativer Impuls auf IC3a, Pin 3 ausgeloeset. Dadurch wird der Transistor Q3 voll durchgesteuert um die Drehzahl der Compact Disc schnell zu erhoehen. Danach regelt nur noch das Signal MCES die Drehzahl.

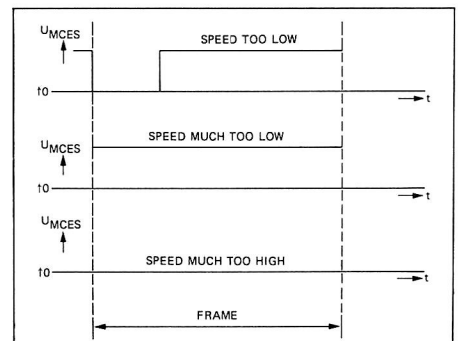

Fig. 3.5

### 3.2 Mikroprozessor PCB 1.769.320

Auf dem Mikroprozessorprint 1.769.320 ist das Mikroprozessorsystem und die Schubladensteuerung untergebracht.

#### 3.2.1 Mikroprozessorsystem

Das Keyboard (Tastatur) wird durch den Master-Mikroprozessor (M-uP, IC2) abgefragt (P00 ... P05, P10 ... P14). Druecken der Taste LOAD bewirkt einen Reset des gesamten Prozessorsystems. Um zwischen einem Netunterbruch und einem LOAD-Befehl zu unterscheiden, wird bei LOAD gleichzeitig P15 des Master-Prozessors auf "L" gezogen. Der Kondensator C12 speichert diesen Zustand solange, bis P15 gelesen wird. Diese unkonventionelle Schaltungsweise hat den Vorteil, dass das Geraet, falls aus irgend einem Grunde das System blockiert werden sollte, jederzeit durch Druecken der LOAD-Taste der Reset-Befehl ausgeloeset werden kann.

Ueber den Interrupt-Eingang des Masterprozessors werden die Befehle vom IR-Empfaenger resp. von der REMOTE-Buchse gelesen. Trifft ein Befehl von der IR-Fernsteuerung ein, so wird das IR-REC-Signal waehrend ca. einer Sekunde auf "LOW" geschaltet. Dadurch leuchtet die LED im IR-Empfaengerfenster (Befehlsempfang-Quittierung).

Die Signale DRA-POS-B und DRA-POS-F informieren den Prozessor ueber die Position der Schublade.

Durch die Signale CLK, DATA, DLEN-1 und DLEN-2 werden die beiden LCD-Treiber PCE 2111 (auf Print 1.769.250) angesteuert.

Die Lautstaerkenveraenderung des Kopfhoererverstaerkers und des Ausgangs VARIABLE OUTPUT wird mit den Signalen CLK, DATA und DLEN-3 (auf Print 1.769.280) gesteuert.

Der Slave-Mikroprozessor (S-uP, IC4) verarbeitet den Subcode (zusaeztlliche Informationen auf der Compact Disc wie Track, Zeit etc). Die dazu benoetigten Signale kommen von Print 1.769.300 (IC13, SAA 7010, Signale Q-SYNC, SWCLK, Q-DATA und P-BIT).

Die Signale RC-0 und  $\overline{\text{RC-0}}$  schalten den Radialregelkreis ein- oder aus. Ist der Radialregelkreis abgeschaltet ( $\overline{\text{RC-0}} = \text{L}$ ), so kann mit den Signalen RC1, RC2, CUR-SUM und CUR-DIR der Laser-Abtaster positioniert werden.

Ueber den Interrupt-Eingang des Slave-Prozessors wird das Tracksignal (TRK) gelesen. Sobald der Laser-Abtaster eine Spur ueberstreicht, wird dieses Signal "L". Die Richtung, in welcher der Laser-Abtaster bewegt wird, wird durch das Signal T1 an den Slave-Prozessor gemeldet. Auch dieses Signal wird "L" sobald eine Spur vom Laser-Abtaster ueberfahren wird. Im Weiteren wird es dazu verwendet, im Suchlauf die Spuren zu zaehlen. Da die Zaehlgeschwindigkeit des Mikroprozessors nicht genuegend hoch ist, wird im schnellen Suchlauf nur jede zweite Spur gezaehlt (Teiler durch 2, IC6b).

Ein ueber das Keyboard eingegebenes Programm wird in IC5 (serielles RAM) gespeichert.

Beide Mikroprozessoren werden durch IC1 (Reset-Baustein TL 7705) gesetzt. Die +5V-STBY-Speisung wird ueber Pin 7 von IC1 ueberwacht. Der Reset wird auch durch Druecken der Taste LOAD ueber R1, R8 und C4 ausgeloeset.

Ueber die REMOTE-Buchse koennen Steuerbefehle von einer Kabelfernbedienung gelesen werden (Pin 2 und Pin 3). Diese Befehle werden ueber den Optokoppler IC 12a galvanisch getrennt. Durch die Komparatorschaltung (IC9a, R44, R45, R48 und R60) werden diese Signale in ein TTL-Signal umgewandelt. Um die Befehle vom Infrarot-Empfaenger stummzuschalten, kann Pin 4 gegenueber Pin 2 auf +5V geschaltet werden. Dazu kann die +5V-STBY-Speisung der REMOTE-Buchse verwendet werden (Pin 1 mit Pin 2 und Pin 4 mit Pin 5 verbinden). Das IR-Signal wird dadurch ueber die Schaltung DLQ2, R41, R42, R43, R62 und IC9b kurzgeschlossen.

### 3.2.2 Schubladenmotor- Steuerung

Der Schubladenmotor- Verstaerker (IC10a, R52,53,56,57,und R58, C14, Q8 und Q9) wird ueber das Schieberegister IC3 (Pin 4 und Pin 5) angesteuert. Wird die Schublade waehrend des Ein- resp. Ausfahrens blockiert, so steigt der Motorstrom und somit die Spannung ueber R64. Dadurch wird das Signal T1 des Masterprozessors "L" (Schaltung R40,54,55,59,63, Q6, Q7, C13 und IC10b). Der Masterprozessor aendert darauf die Richtung der Schublade.

### 3.3 SERVO- 2 PCB 1.769.330

Der Servoprint 2 1.769.330 beinhaltet die Schaltungen fuer die Radialregelung und den IR- Empfaenger.

#### 3.3.1 Radialregelung

Damit der Laser- Abtaster der Spur horizontal folgen kann, ist er in einen Dreharm eingebaut. Grundsaeztlich funktioniert dieser vergleichbar mit einem Drehspulinstrument.

Die Schaltung fuer die Radialregelung kann in vier Bloecke unterteilt werden:

- eigentliche Radialregelung
- AGC- Schaltung
- Offset- Kontrollschaltung
- Spurdetektorschaltung

#### 3.3.2 Eigentliche Radialregelung

Der Wert des Radialfehlersignals RE kann auf folgende Art berechnet werden:  $RE = kd (I1 + I2 + I3 + I4) - k (I1 + I2)$ .

Der Wert von k wird durch die AGC- Schaltung und d durch die Offset- Kontrollschaltung bestimmt.

$$RAD-ERR2 = I1 + I2$$

$$RAD-ERR1 = I3 + I4$$

Ueber die Schaltung IC9b, R58/59/61/62/63 und Q6 werden die Signale RAD-ERR 1 und RAD-ERR 2 summiert. Die Summe fliesst als Strom durch R63 und Q6. Das Fehlersignal RAD-ERR 2 wird ueber R55 und R57 in einen Strom umgewandelt und fliesst durch R54 und Transistor E von IC8. Der Faktor k wird durch die Transistoren A und B sowie C und D (IC8), Faktor d durch Q5 und Transistor F (IC8) gebildet.

An Pin 9 von IC9c erscheint das Signal  $RAD-ERR2 \times k (=k \{I1 + I2\})$ , an Pin 10 von IC9c das Signal  $\{RAD-ERR1 + RAD-ERR2\} kd (= kd \{I1 + I2 + I3 + I4\})$ . Das Differenzsignal (RE), gebildet in IC9c erscheint an Pin8 ( $RE = kd \{I1 + I2 + I3 + I4\} - k\{I1 + I2\}$ ). Das "Lag"- Netzwerk der Radialregelung wird durch R66, R67, R68, C15 und IC9d gebildet, das "Lead"- Netzwerk durch R69, R70 und C16. Das Signal wird ueber die Schutzdioden D5 und D6 auf IC5 gefuehrt. Ueber Schalter B (IC5) gelangt das Signal auf Pin 2 von IC2. IC2 bildet zusammen mit Q2, Q3, R6, R7, R8, RT1 und C5 die Endstufe fuer das Radialregelsignal RAD-MOT+/- RAD-MOT-. RT1 ist ein Schutz fuer die Spule. Ueber Schalter B (IC5) kann die Radial-

regelung ausgeschaltet werden (Signal  $\overline{RC-0}$ ). Dies ist im schnellen Suchlauf, Pause, im Vor- und im Ruecklauf der Fall. In dieser Phase kann der Laser- Abtaster mit den Signalen RC-1, RC-2, CUR-DIR und CUR-SUM positioniert werden.

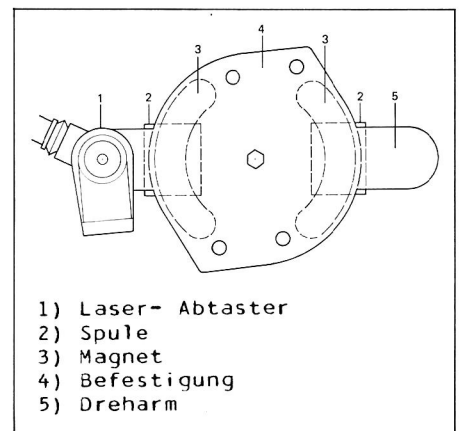

Fig. 3.6

**3.3.3 Automatic Gain Control- (AGC-) Schaltung**

Die Bandbreite des Radialregelkreises wird mit dieser Schaltung konstant gehalten. In der Schaltung IC10c, IC11d, C22, C23, C24, C25, R85, R86, R87, R90 und R91 wird ein 650Hz- Sinussignal erzeugt, welches in den Radialregelkreis eingespiesen wird. Wird die Verstaerkung groesser oder kleiner, so wird auch die Phasenlage des eingespiesenen Signals gegenueber dem rueckkehrenden Signal groesser resp. kleiner. Im Phasendetektor (IC11) werden die beiden Signale verglichen und eine Resultierende gebildet. Diese ist proportional zur Phase und auch zur Verstaerkung. Dieses Signal kontrolliert den Faktor k. Die Verstaerkung ist fuer eine Phasenverschiebung zwischen den Signalen von -135% eingestellt. Das 650Hz- Sinussignal wird deshalb ueber einen 45%-Phasenschieber (R84, C21) auf Pin 13 von IC9d in den Regelkreis eingespiesen. Am Eingang des Phasendetektors (IC11c) ist die Phasenverschiebung 90%. Ueber ein Bandpassfilter wird das 650Hz- Sinussignal aus dem Regelkreis herausgefiltert (IC10d, R82, R83, C19, C20) und in IC11a in ein Rechtecksignal umgewandelt. Dieses Rechtecksignal wird dem Phasenkomparator (IC11c, Pin 8) zugefuehrt. Die Phasenreferenz liefert Pin 9 von IC11c.

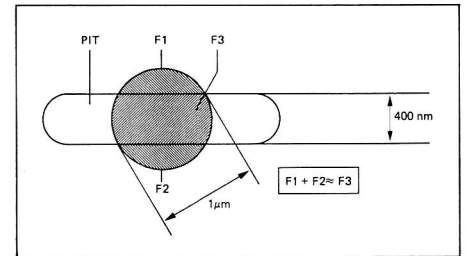

Fig. 3.7

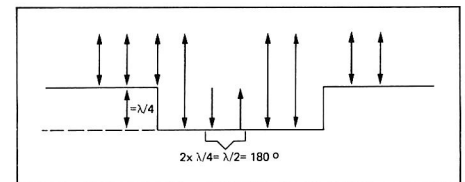

Fig. 3.8

**3.3.4 Offset- Kontrollschaltung**

Mit dieser Schaltung wird die Asymmetrie des reflektierten Laserstrahls korrigiert, damit der Laserstrahl genau in der Mitte der Spur gehalten wird. Wenn der Laserstrahl genau in der Mitte der Spur laeuft, ist der Unterschied von minimaler zu maximaler Reflexion am groessten (ein Pit = minimale Reflexion, zwischen den Pits = maximale Reflexion).

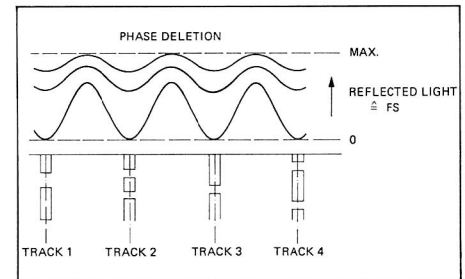

Fig. 3.9

Durch das 650Hz- Sinussignal schwingt der Dreharm in der Spur mit einer Amplitude von 0,05µm. Ist der Laserstrahl in der Mitte der Spur, so werden saemtliche Halbwellen des herausgefilterten Signals auf die gleiche (positive) Seite gefaltet. Ist der Laserstrahl rechts der Spur, ist das Signal in Phase mit dem 650Hz- Schwingung des Dreharms, links davon gegenphasig.

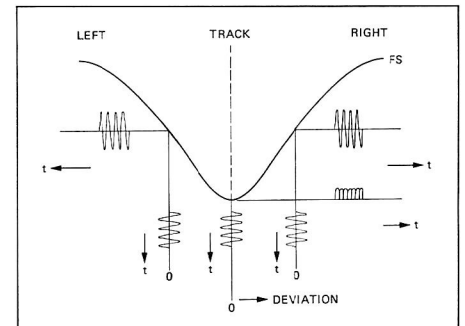

Fig. 3.10

Die Spannung ueber R63 ist proportional zur reflektierenden Lichtintensitaet (I1+I2+I3+I4). Ueber IC6a, R30, R31 und R64 wird die Spannung verstaerkt und in einem Bandpass- Filter die 650Hz- Komponente herausgefiltert (R32, R33, R34, R35, R37, C11, C12 und IC7b). Ueber IC7a, R36 und R38 wird das gefilterte Signal invertiert. Diese und das nicht invertierte Signal werden auf Schalter C von IC5 gefuehrt. Der Ausgang dieses Schalters (IC5, Pin 4) wird ueber IC7d und C30 integriert und bestimmt den Faktor d (Q5 und Transistor F von IC8). Der Zustand des Schalters C (IC5) wird durch das 650Hz- Signal im Regelkreis geschaltet. Dies geschieht ueber den Bandpass R42, R43, R44, R45, C13, C14, D4 und IC7c.

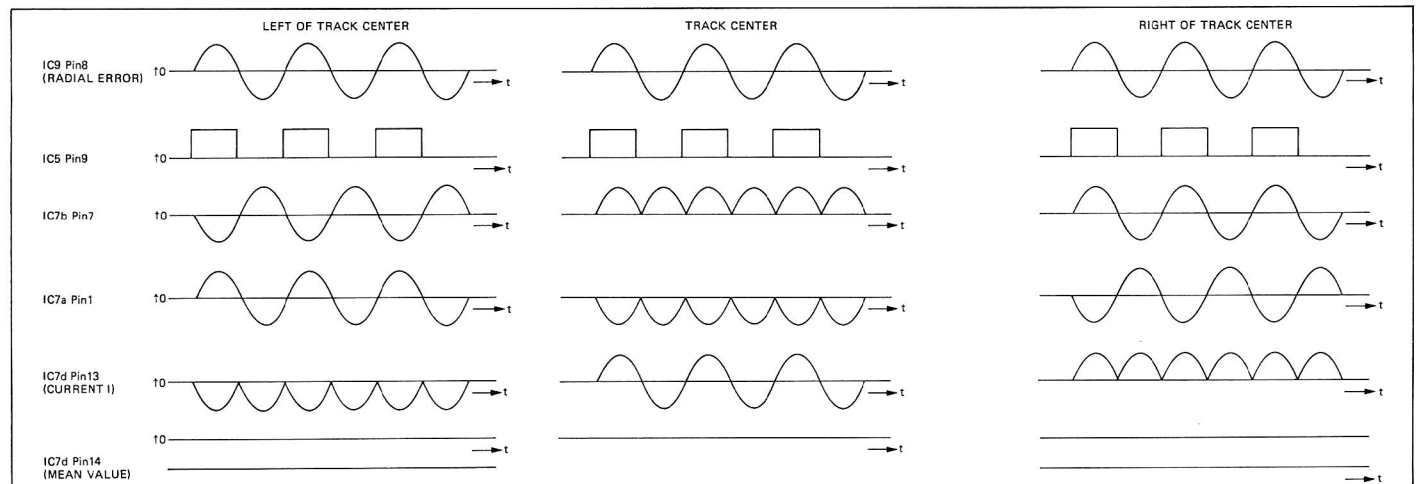

Fig. 3.11

### 3.3.5 Spurdetektorschaltung

Am Interrupt- Eingang des Slaveprozessors werden die Spuren gelesen, welche der Laser- Abtaster ueberstreicht (TRK-SIG). Dieses Signal wird aus dem an IC6, Pin 1 anstehenden Signal (proportional zu  $\{I1+I2+I3+I4\}$ ), dem DO- und dem HFL- Signal gebildet. Wird auf der CD keine Fehlerstelle detektiert, so ist das Signal DO = "L".

Fig. 3.12

Das HFL- Signal ist "H", wenn das HF- Signal genuegend gross ist. Das TRK- Signal ist nur "L", wenn das HF- Signal zu klein ist. Bei jeder Spur, welche uebersprungen wird, ist HFL = "L", falls keine Fehlerstelle auf der CD detektiert ist (DO="L"). Das Radialfehlersignal RE (IC9c, Pin 8) informiert, ob der Laser- Abtaster links oder rechts von der Spur steht. Das dafuer benoetigte Signal (RAD-POS) wird ueber IC3c, R12, R19 und R20 aus dem Radialfehlersignal RE erzeugt.

### 3.4 Preamplifier und Laser PCB (auf dem Laufwerk)

Dieser Print beinhaltet folgende Schaltungen:

- Laseransteuerung
- Regelsignale fuer die Fokus- und Radialregelung
- HF- Signalverstaerker

#### 3.4.1 Laseransteuerung

Die Laserdiode wird ueber Transistor BD 226 gespeist. Durch die Monitorphotodiode kann die Intensitaet des Lasers kontrolliert und mit Trimpotentiometer LASER OUTPUT eingestellt werden. Das Signal LAS-OFF (von Print 1.769.315 / IC1) schaltet den Laser ein resp. aus.

#### 3.4.2 Regelsignale fuer die Fokus- und Radialregelung

In dieser Schaltung werden die folgenden Signale erzeugt:

- FOC-ERR
- RAD-ERR1
- RAD-ERR2

Die Stroeme der vier Photodioden (A1 ... A4) werden in IC NE 5514 verstaerkt. Durch das nachfolgende Netzwerk werden die entsprechenden Fehlersignale gebildet. Das Fokus- Fehlersignal ist proportional zu  $(I1+I4) - (I2+I3)$ .  $I3 + I4$  bilden das RAD-ERR1- Signal,  $I1 + I2$  das RAD-ERR2- Signal. Mit Trimpotentiometer FOCUS GAIN kann die Verstaerkung des Fokus- Regelkreises eingestellt werden, mit Trimpotentiometer FOCUS OFFSET die Symmetrie.

#### 3.4.3 HF- Signalverstaerker

Die Schaltung mit den Transistoren Q1 bis Q7 bildet den HF- Signalverstaerker mit Bandpass-Charakteristik. Tief-frequente (z.B. Regelsignale der Servos) und hochfrequente Stoersignale werden dadurch herausgefiltert.

### 3.5 Decoder PCB 1.769.300

Der Decoderprint enthaelt folgende Schaltungen:

- Digitale Signalverarbeitung
- Digitaler Sinusgenerator
- HFL- und DO- Detektor

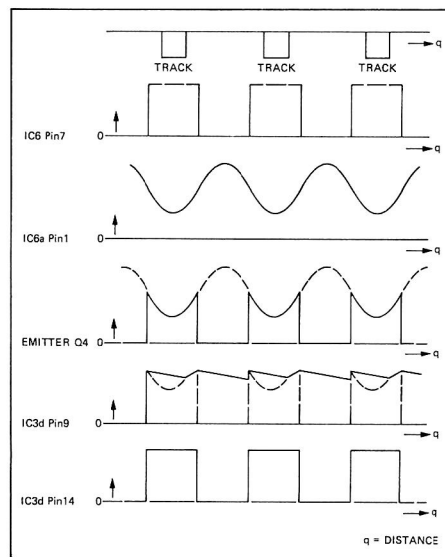

Fig. 3.12

### 3.5.1 Digitale Signalverarbeitung

Das HF- Signal wird in IC13 (SAA 7010) in digitale Daten umgewandelt und unterteilt in Audio- und Informationsdaten (Subcode, fuer den Slave- Prozessor). In IC13 wird auch das CLOCK- Signal regeneriert. Ueber IC12 zusammen mit IC14 werden die Audiodaten auf den richtigen Zeitraster gebracht. Fehlerhafte Audiodaten werden dabei in IC12 erkannt und bei Bedarf korrigiert. Sind die Fehler allerdings nicht mehr korrigierbar, so werden die fehlenden Abtastwerte in IC10 (SAA 7000) durch Interpolation ersetzt. Falls auch dies nicht mehr moeglich waere, wird das NF- Signal langsam stummgeschaltet (soft muting). Die Drehzahl des CD- Motors wird durch das Signal MCES (IC1, Pin 4) geregelt.

### 3.5.2 Digitaler Sinusgenerator

Im PROM (IC4) ist eine Wertetabelle fuer das Sinussignal gespeichert, welches den maximal moeglichen Pegel einer CD darstellt. Die Schaltung besteht aus IC5 bis IC9, wobei IC5 und IC6 die Adressen fuer das PROM liefert. Die parallel/seriell- Umwandlung der Daten geschieht in IC3. Die Umschaltung zwischen Audiodaten von der CD und dem 1kHz- Sinussignal wird durch IC1 gesteuert.

### 3.5.3 HFL- und DO- Detektor

Das HF- Signal wird ueber C6 und R2 in den invertierenden Differenzverstaerker Q1 und Q2 eingespiesen. Ueber C8 resp. C9 werden die Ausgangssignale DC- entkoppelt und ueber D2 und D3 DC- maessig an Masse gebunden. D4 und D5 resp. D6 und D7 bilden je einen Vollwellengleichrichter ueber welche die Kondensatoren C10 resp. C11 geladen werden. Bei normalem HF- Signal ist das DO- Signal "L" und das HFL- Signal "H". Sinkt das HF- Signal auf etwa 75% des normalen Wertes, wird auch das HFL- Signal "L". Erst wenn das HF- Signal auf etwa 10% des normalen Wertes sinkt, aendert das DO- Signal auf "H".

Um zu verhindern, dass die Ausgangssignale von IC11 sich schon bei geringen Verschmutzungen der CD (z.B. Fingerabdruecken) stark veraendern, wurde der Transistor Q3 nachgeschaltet. Weist der HF- Pegel den Nennwert auf, ist Pin 7 von IC11 "H". Dadurch wird Q3 leitend und die Schaltung mit C11 erhaelt eine kleinere Zeitkonstante. Bei Pegelschwankungen, verursacht durch geringe Verschmutzungen, werden parallel dazu die Pegel der beiden Ladekondensatoren schwanken, dadurch veraendern sich allerdings weder das DO- noch das HFL- Signal.

## 3.6 DAC PCB 1.769.280

Folgende Schaltungen befinden sich auf diesem Print:

- Digitale Filterung (Oversampling) und Digital-/Analog- Wandlung
- PegelEinstellung und KopfhoererVerstaerkung

### 3.6.1 Digitale Filterung (Oversampling) und D/A- Wandlung

IC1 (SAA 7030) enthaelt zwei identische Filter fuer die beiden Kanaele. Die Filter sind dreiteilig aufgebaut:

- Oversampling- Teil ("Ueberabtastung")
- Transversal- Digitalfilter
- Noise Shaper

In die vom Decoder kommende 16 Bit- Information wird nach jeder Abtastung durch Interpolation drei neue Abtastwerte eingefuegt. Die Abtastrate wird dadurch viermal groesser ( $4 \times 44,1 \text{ kHz} = 176,4 \text{ kHz}$ ). Danach werden im Transversalfilter die Spektrallinien oberhalb von 20 kHz bis  $176,4 \text{ kHz} - 20 \text{ kHz}$  herausgefiltert. Die Abtastwerte werden auf 14 Bit abgerundet. Der Abrundungsfehler wird danach durch den "Noise Shaper" um die Abtastdauer verzoegert und dem zeitlich naechsten Abtastwert negativ dazuaddiert. Dadurch wird das durch das Runden verursachte Quantisierungsrauschen mehrheitlich gegen den Frequenzbereich oberhalb 20 kHz verschoben. Das digitale Signal wird in IC101 resp. IC201 (TDA 1540) in ein analoges Signal umgewandelt. Um die noch verbleibende Frequenzkomponente bei  $n \cdot (176,4 \text{ kHz} \pm 20 \text{ kHz})$  herauszufiltern, wird nach dem Wandler noch ein Tiefpassfilter dritter Ordnung (Bessel- Filter) nachgeschaltet.

Die Preemphasis wird mit der Schaltung gemäss Fig. 3.13 korrigiert. Der Subcode auf der CD informiert darüber, ob ein Titel mit oder ohne Preemphasis aufgenommen worden ist. Mit dem PREEM-Signal kann entsprechend die Charakteristik des Filters angepasst werden.

**3.6.2 Pegeleinstellung und Kopfhörerverstärker**

Die Volumensteuerung wird durch einen DUAL D/A-Wandler (AD7528) geregelt. Sie dienen als Abschwächer vor dem entsprechenden Eingang (IC103a, Pin 2 = linker Kanal / IC203b, Pin 6 = rechter Kanal). Die Gegenkopplungswiderstände beider Operationsverstärker bleiben konstant, dadurch kann der Pegel mit dieser Schaltung nur abgeschwächt werden. Der Dual-D/A-Wandler wird über ein CMOS Schieberegister durch die Signale DLEN-3, DATA und CLK angesteuert. Die Schaltung gem. Fig. 3.14 bildet den Endverstärker für den Kopfhöreranschluss und ebenfalls für den Ausgang VARIABLE OUTPUT. Dafür wird das Signal allerdings noch über einen Spannungsteiler abgeschwächt, damit das maximale Signal an beiden Ausgängen (FIXED und VARIABLE) gleich gross ist (2V RMS). Um Einschaltknackse zu vermeiden, wird das Signal über Relais K1 geführt. Wird das Gerät eingeschaltet, so wird das Relais durch

das  $\overline{\text{KILL}}$ -Signal angesteuert (nach ca. 1 bis 2 Sekunden steigt das Signal  $\overline{\text{KILL}}$  auf +5V). Dadurch werden die Ausgänge erst durchgeschaltet, wenn die Speisespannungen stabil sind.

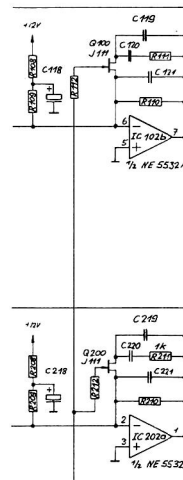

Fig. 3.13

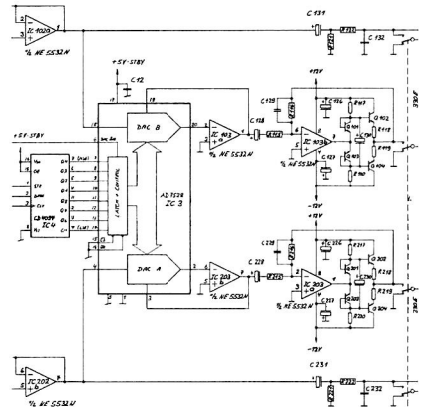

Fig. 3.14



4. MESSPUNKTE, EINSTELLUNGEN AM B225

4.1 Messpunkte am B225

4.1.1 Messpunkte auf Servo 1 PCB 1.769.310

TP	POWER-ON	POWER-OFF
1	+5V +/-5%	+5V +/-5%
2	+5V +/-5%	+1,3V
3	-7V +/-5%	-1,3V
4	+12V +/-5%	+1,3V
5	-12V +/-5%	-1,3V
6	-17V +/-5%	-1,3V

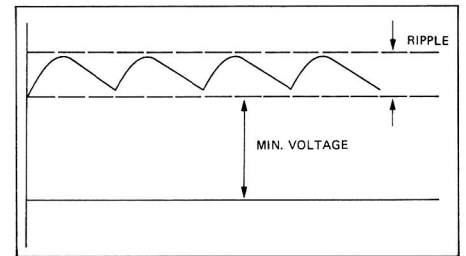

Fig. 4.1

TP	POWER-ON		POWER-OFF	
	Umin.	Rippel	Umin.	Rippel
7	+12V	0,8V	+13,5V	0,3V
8	-14V	0,3V	-15V	0,1V
9	+18V	0,8V	+21V	0,2V
10	-18V	0,8V	-21V	0,2V
11	-27V	3,4V	-38V	0,9V

TP 7 ... TP11 siehe auch Fig. 4.1.

TP	POWER-ON	POWER-OFF
12	0V	+5V
13	0V	+0,7V
14	+1,6V	-0,7V
15	0V	+0,7V
16	+6,5V	-0,7V
17	+6,5V	-0,7V
18	14V	15V
19	14V	15V
20	20V	22V
21	20V	22V

TP18 ... TP21 siehe auch Fig. 4.2.

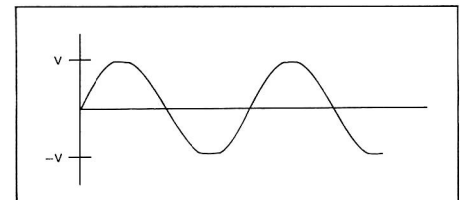

Fig. 4.2

TP	Schubladenposition		
	eingefahren	in der Mitte	ausgefahren
22	0V	+5V	+5V
23	0V	0V	+5V

TP	PLAY- Mode	STOP- Mode	TP	PLAY- Mode	PAUSE/Suchlauf
24	0V	+5V	28	+5V	0V
25	0V	+5V			
26	0V	0V			
27	0V	0V			

Ist bei PLAY- Wahl keine CD eingelegt, werden die Signale an den Testpunkten 26 und 27 viermal abwechselungsweise fuer ca. eine Sekunde +5V.

TP	Preemphasis	TP	PLAY- Mode	Suchlauf
	ja   nein	30	+5V	0V
29	+5V   0V			

TP	PLAY- Mode	STOP- Mode	TP	PLAY- Mode	Suchlauf
31	0V	0V	38	2,6V	-0,7V
32	0V	0V			
33	0V (*)	0V			
34	0V	0V			
35	0V (*)	0V			
36	0V (*)	0V			
37	0V (*)	0V			

(\*) Der Signalverlauf dieser Testpunkte ist im PLAY- Mode vom Hoehenschlag der eingelegten CD abhaengig.

TP	PLAY- Mode	STOP- Mode	
39	7,5kHz (a)	0V	(a) = TTL- Rechtecksignal
40	+2,5V	+2,5V	
41	+2,7V	+0,1V	
42	+2,7V	+0,6V	
43	~2Vpp (b)	-11V	(b) = Regelsignal
44	+2,5V	+0,6V	
45	-2,8V (c)	+8,2V	(c) = Regelsignal, 0,8Vpp ueberlagert
46	- 2V (c)	0V	
47	-6,5V (d)	- 7V	(d) = Regelsignal, 0,3Vpp ueberlagert

4.1.2 Testpunkte auf Servo 2 PCB 1.769.330

TP	STOP- Mode	PLAY- Mode	
1	0V	-1V	
2	0V	-1V	
3	0V	0V	
4	0V	0V	
5	0V	+0,6V	
6	0V	+0,3V	
7	0V	+4,4V	
8	0V	~2Vpp	(siehe Fig. 4.3 D)
9	0V	~2Vpp	(siehe Fig. 4.3 D)
10	0V	~2Vpp	(siehe Fig. 4.3 B)
11	0V	~2Vpp	(siehe Fig. 4.3 A)
12	+0,1V	0V	
13	-12V	~+6V	
14	0V	650Hz TTL	(Rechteck, siehe Fig. 4.3 C)
15	+9,5V	+8,4V	
16	+9,5V	+8,4V	
17	0V	1Vpp 650Hz	(Sinus)
18	0,4Vpp 0,2V DC	0,6Vpp	(650Hz, Sinus)
19	0V	+5V	
20	+5V	0V	
21	+5V	0V	im Suchlauf: zeitweise +5V
22	0V	0V	Impulse bis +1V
23	0V	0V	Impulse +5V
24	0V	0V	Impulse +5V
25	+0,1V	0V	
26	+0,1V	0V	
27	+1V	4Vpp 650Hz Sinus	
28	9Vpp 650Hz Sinus, 3VDC	9Vpp 650Hz Sinus, 3VDC	
29	650Hz TTL	650Hz TTL	(Rechteck, siehe Fig. 4.3 E)
30	650Hz TTL s. Fig. F	650Hz TTL s. Fig. H	
31	+8,7V	+8,7V	
32	+2,5V	+2,5V	
33	1300Hz TTL (Fig. G)	1300Hz TTL (Fig. I)	(Rechteck)

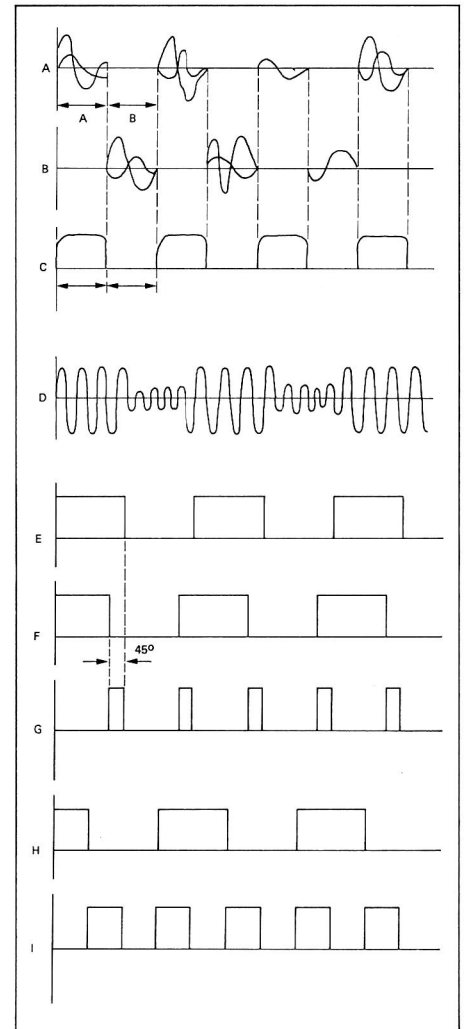

Fig. 4.3

34	+10,5V	-4V	
35	+2,5V	+2,5V	
36	+5V	+4,9V	
37	+5V (e)	+5V	(e) = Das Signal an TP37 faellt bei Umschalten von Stop auf Play kurzfristig auf 0V.
38	650Hz TTL Rechteck	650Hz TTL Rechteck	
39	+0,8V	0V	im Suchlauf: 0V
40	+0,2V	+5V	wechselnd 0V/5V
41	0V	+5V	wechselnd 0V/5V
42	+5V	0V	wechselnd 0V/5V
43	0V	+5V	wechselnd 0V/5V
44	+3,7V	+3,7V	wechselnd 4V/8V
45	0V	+4,2V	wechselnd 3V/6V
46	0V	+3,5V	wechselnd 3,2V/5,6V
47	0V	+4,8V	

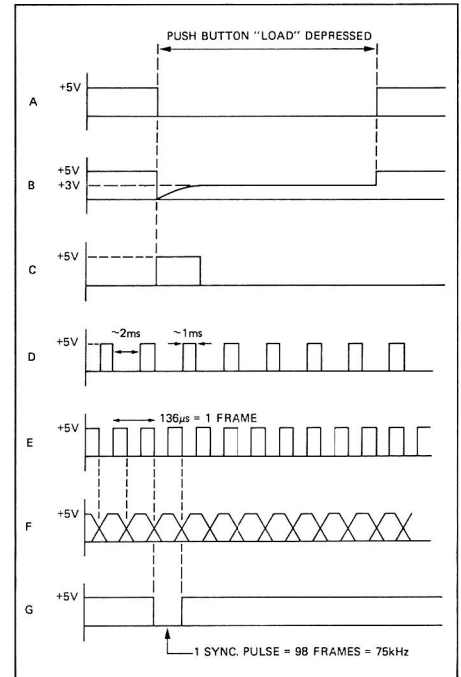

Fig. 4.4

TP	POWER-OFF	POWER-ON
48	+4,3V	+5V
49	+5V	0V
50	+5V	+5V
51	+0,4V	+0,4V
52	+0,3V	+0,3V

Werden Signale von der IR- Fernbedienung empfangen, so entstehen an TP52 Spannungsimpulse von +4,3V.

**4.1.3 Testpunkte auf Mikroprozessor PCB 1.769.320**

TP	STOP-/PLAY-Mode	Schublade	
1	0V	faehrt aus	faehrt ein
2	0V	+5V	0V
3	0V	+10V	-10V
4	0V	+0,4V	-0,4V
5	+5V	+5V	+5V

Bei Ein- und Ausfahren, Richtungswechsel und Blockieren der Schublade faellt das Signal an TP5 kurzfristig auf Null.

TP	STOP-/PLAY-Mode	Druicken der Taste LOAD
6	+5V	0V (Fig. 4.4 A)
7	+5V	+3V (Fig. 4.4 B)
8	0V	+5V-Impuls ca. 30ms
9	+5V	+0,7V (Fig. 4.4 C)

IP	keine Taste gedrueckt	entspr. Taste gedrueckt
10	0V	TTL-Signal Fig. 4.4 D
11	+5V	TTL-Signal Fig. 4.4 D

TP	Schublade		
	eingefahren	Mitte	ausgefahren
12	0V	+5V	+5V
13	0V	0V	+5V

IP	ohne IR-Befehle	mit IR-Befehlen
14	+0,9V	3,8V-Impulse

IP	PLAY- Mode	
15	3,8Vpp*	* = Sinus 4,4336MHz
16	3,5Vpp*	* = Sinus 6,0000MHz
17	+5V	(Schublade ausgefahren = 0V)
18	+5V	(CAL. TONE 1000Hz = 0V)
19	TTL-Signal	(Subcode- Synchronisation 75Hz)
20	TTL-Signal	\
21	TTL-Signal	
22	TTL-Signal	
23	TTL-Signal	
24	TTL-Signal	
24	TTL-Signal	Diese Signale sind sporadisch (nicht periodisch und lassen sich deshalb nicht darstellen. Es handelt sich dabei um die Clock-, Daten- und Enable- Signale.
26	TTL-Signal	
27	TTL-Signal	
28	TTL-Signal	/

IP	Pause von CD	keine Pause von CD
29	+5V	0V

IP	PLAY- Mode	Suchlauf	
30	+5V	0V*	* = bei jeder Spur welche uebersprungen wird
31	650Hz TTL	TTL-Sig.	\
32	650Hz TTL	TTL-Sig.	Spuren, welche uebersprungen werden
33	650Hz TTL	TTL-Sig.	/
34	0V	zeitw.+5V	
35	+5V	zeitw.0V	
36	0V	zeitw.+5V	

TP	Buchse REMOTE	
	offen	Pin 1/2 und 4/5 verb.
37	+0,3V	+0,1V
38	0V	+5V
39	+1,7V	+1,7V
		Pin 1/2 und 3/5 verb.
40	+4,2V	+4,2V
41	+5V	0V
42	0V	+3,7V

#### 4.1.4 Testpunkte auf Decoder PCB 1.769.300

TP	STOP- Mode	PLAY- Mode	
1	-0,7V	DC -0,7V, AC 1,4Vpp	(CD-Daten)
2	+5V	DC +3V, AC 4Vpp	
3	+5V	DC +3V, AC 4Vpp	
4	+2V	+2V	
5	+2,1V	+4,6V	
6	4,5MHz *	8,5MHz *	* = AC 3,3Vpp (Sinus), DC +1,8V
7	4,5MHz (a)	8,5MHz (b)	a = AC 1,9Vpp (Sinus), DC +1,8V b = AC 1,7Vpp (Sinus), DC +1,8V
Beim Wechsel von PLAY auf STOP, faellt die Frequenz in ca. 20 Sekunden auf 4,5MHz.			
8	-7,9V	-7,9V	
9	-8,6V	-8,6V	
10	-7,9V	-7,9V	
11	-0,2V	+0,6V	
12	-0,5V	+4,3V	
13	-0,5V	+5,8V	
14	-0,3V	+0,1V	
15	+0,9V	+0,1V	+0,1V
16	0V	+5V	0V * * immer bei Spur-ueberspringen

#### Test mit CD- Testplatte Best. Nr. 46241

An der Plattenoberflaeche sind auf Track 17 schwarze Punkte (Black Dots) aufgebracht. Waehrend des Abspielens dieses Tracks sollte folgendes gemessen werden:

TP	Messung
15	+5V- Impulse bei den Black Dots
16	0V- Impulse bei den Black Dots

IP	PLAY- Mode
17	TTL- Signal Fig. 4.5 D
18	TTL- Signal Fig. 4.5 B
19	TTL- Signal Fig. 4.5 A
20	TTL- Signal Fig. 4.5 C
21	TTL- Signal Fig. 4.6 F
22	TTL- Signal Fig. 4.6 E
23	TTL- Signal Fig. 4.6 G
24	TTL- Signal Fig. 4.6 H
25	TTL- Signal Fig. 4.7 K
26	TTL- Signal Fig. 4.7 L
27	4,233MHz, Sin. 5Vpp
28	TTL- Signal Fig. 4.7 M
29	TTL- Signal Fig. 4.7 I
30	TTL- Signal Fig. 4.8 O
31	TTL- Signal Fig. 4.8 Q
32	TTL- Signal Fig. 4.8 P
33	TTL- Signal Fig. 4.8 P
34	TTL- Signal Fig. 4.9 N
35	TTL- Signal Fig. 4.9 R
36	TTL- Signal Fig. 4.9 S
37	TTL- Signal Fig. 4.9 T
38	TTL- Signal Fig. 4.9 U
39	TTL- Signal Fig. 4.9 V
40	-2,7V

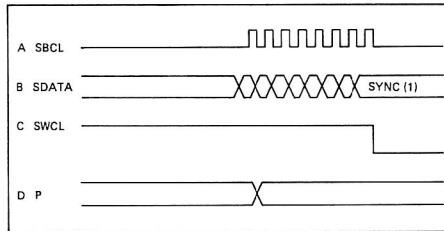

Fig. 4.5

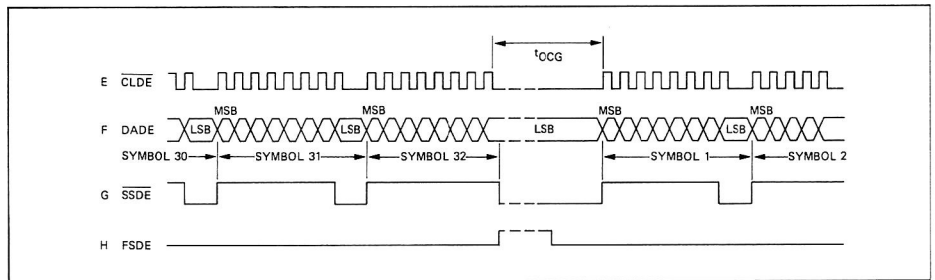

Fig. 4.6

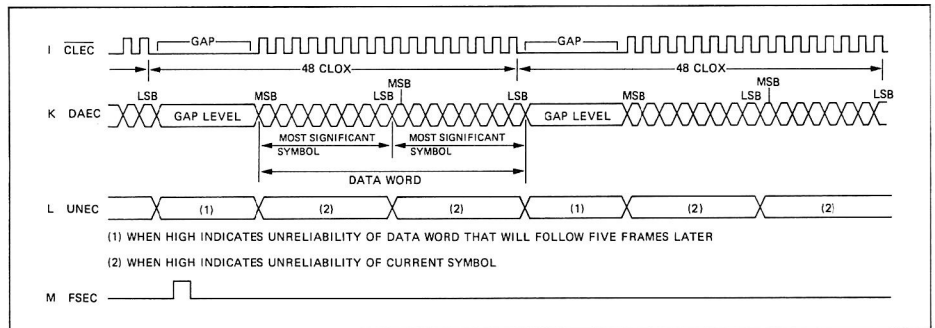

Fig. 4.7

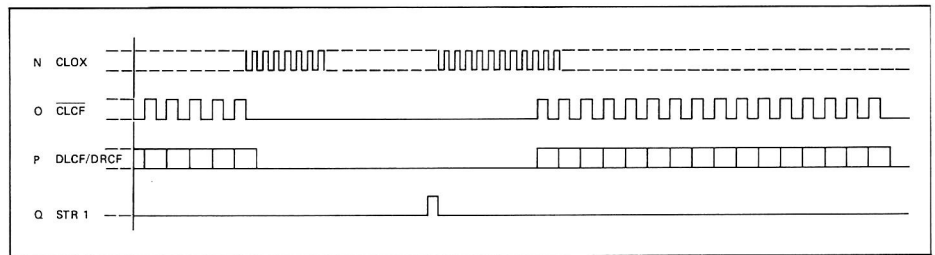

Fig. 4.8

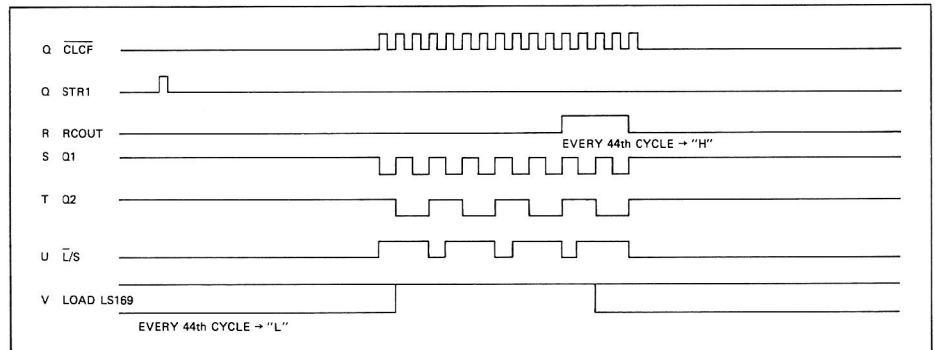

Fig. 4.9

**4.1.5 Testpunkte auf DAC- PCB 1.769.280**

Fuer die folgenden Messungen muss der interne Kalibrierton eingeschaltet sein.

TP	Messung	
1	TTL- Signal Fig. 4.10 A	
2	TTL- Signal Fig. 4.10 B	
3	TTL- Signal Fig. 4.10 C	
4	TTL- Signal Fig. 4.10 D	
5	TTL- Signal Fig. 4.10 E	
6	TTL- Signal Fig. 4.10 F	
7	TTL- Signal Fig. 4.10 G	
8	-5V 5%	
9	0V *	* Beim Abspielen einer CD mit Preemphasis +5V.
10	-12V *	* Beim Abspielen einer CD mit Preemphasis +12V.
11	Sinus 1kHz, 6Vpp	
12	Sinus 1kHz, 6Vpp	
13	Sinus 1kHz, 6Vpp	
14	Sinus 1kHz, 6Vpp	
15	Sinus 1kHz, 6Vpp	
16	Sinus 1kHz, 14,5Vpp	\   maximaler Pegel, der Pegel   = dieser Testpunkte kann mit   den Tasten VOLUME einge-   stellt werden. /
17	Sinus 1kHz, 14,5Vpp	
18	Sinus 1kHz, 6Vpp	
19	+5V *	* Schublade ausgefahren = 0V
20	+12V *	* Schublade ausgefahren = -12V

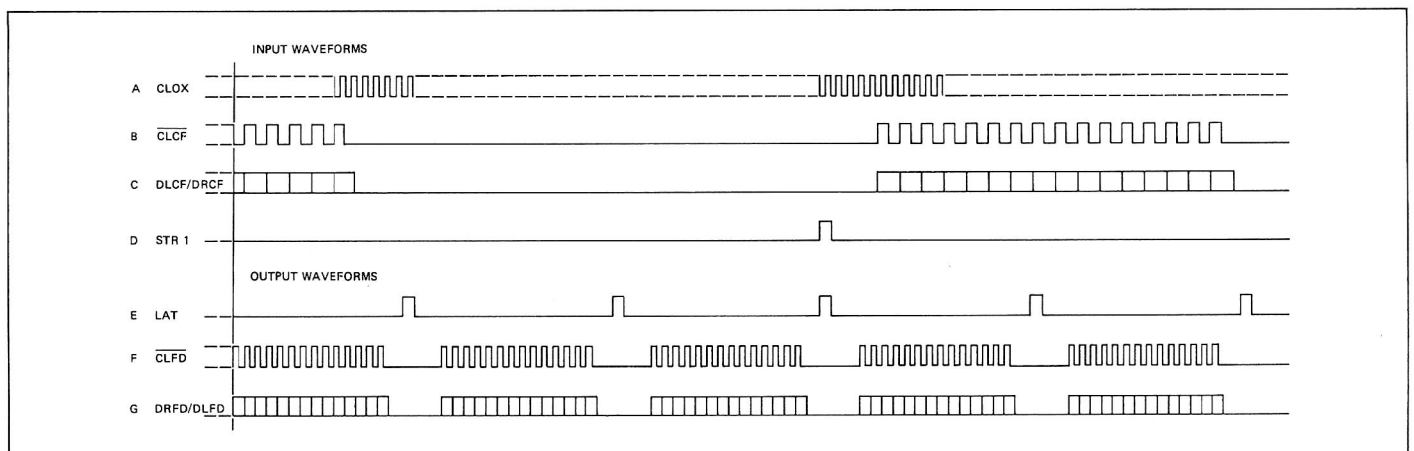

Fig. 4.10



#### 4.2 Einstellungen am CD- Player B225

##### Bemerkung:

Sauberkeit am Arbeitsplatz ist hoeschstes Gebot. Nur dadurch ist gewaehrleistet, dass kein Schmutz oder lose Metallteile in den CD- Mechanismus gelangen.

Falls Arbeiten an den Printkarten notwendig sind, muessen unbedingt die ESE- Hinweise (siehe letzte Seite Inhaltsverzeichnis) beachtet werden.

Vor Inbetriebnahme des Geraetes ist darauf zu achten, ob die Transportsicherungsschrauben geloest sind.

Das CD- Laufwerk ist mit selbst- schmierenden Lagern versehen und darf nicht geschmiert werden.

Wenn fuer Messungen oder Einstellungen der Betrieb des Geraetes mit offener Schublade und eingelegter CD erforderlich ist, muss die hintere Gabellichtschranke unterbrochen werden (der Sensor detektiert dadurch "Schublade eingefahren") und die CD mit einem ausgebauten Haftmagneten fixieren.

Die Laser- Optik kann mit einem Luftpinsel gereinigt werden.

Der Schwingkreis bestehend aus Kapazitaetsdiode DZ1 (8B2/2) und der Spule L1 auf dem Decoder Print 1.769.300 wird durch IC13 (SAA7010) automatisch abgeglichen. Fuer eine Basiseinstellung siehe 4.2.8.

##### 4.2.1 Hilfsmittel

- DC- Voltmeter
- Kathodenstrahl- Oszilloskop
- CD- Testplatte Frequenzgang Best. Nr. 46240
- CD- Testplatte Drop Outs Best. Nr. 46241
- Glas - CD fuer Optikeinstellungen Best. Nr. 46242
- Set Serviceprints und Kabel Best. Nr. 46230
- Set ESE- Arbeitsplatz Best. Nr. 46200

##### 4.2.2 Laufwerkabgleich, Allgemeines

- Oberes Deckblech entfernen.
- Geraet ans Netz anschliessen und mit Taste LOAD die Schublade ausfahren.
- Hintere Lichtschranke abdecken.
- Testplatte 5 (Best. Nr. 46241) auflegen und mit einem ausgebauten Haft- Magneten fixieren.
- Fuer saemtliche Einstellarbeiten wird das Geraet auf PLAY Stueck 1 der CD betrieben. Es ist also von Vorteil ueber den Programmiermodus die Funktion LOOP einzugeben.

##### 4.2.3 Laserstrom einstellen

- Geraet ausschalten, Servo-2 PCB 1.769.330 ausbauen und ueber Service-Print (Best. Nr. 46230) wieder einstecken.
- Linke Spannfeder fuer Gehaeusedeckel mit Kreuzschlitz- Schraubenzieher loesen und etwas nach rechts drehen um Kurzschluss mit den Kontakten von Servo-2 PCB zu verhindern (siehe Fig. 4.12).
- Abdeckung des IR-Empaengers auf Servo-2 PCB 1.769.330 mit einem Stueck Papier gegen den benachbarten Print isolieren.
- Geraet an der Tischkante aufstellen, damit die ausgefahrene Schublade von unten zugaenglich ist.

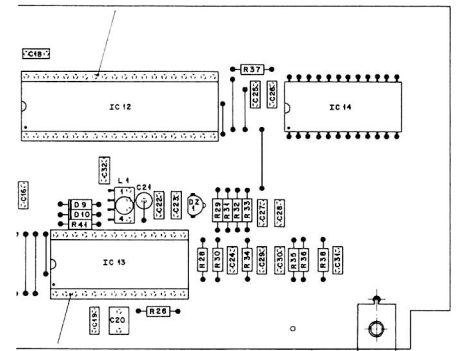

Fig. 4.11

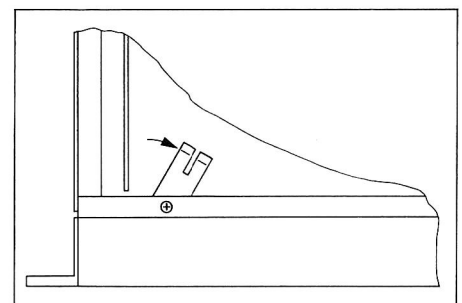

Fig. 4.12

- DC-Voltmeter (Bereich 1,5V DC) an R63 auf Servo-2 PCB anschliessen (siehe Fig.4.15, Pfeil).
- Gerat einschalten und mit PLAY/NEXT Track 1 der Referenz CD (Best. Nr.46241) starten.
- Mit Trimpotentiometer LASER OUTPUT (auf Laufwerk 1.769.100.35/.36, Fig. 4.13/.14) die Spannung an R63 auf 500mV +/- 50mV einstellen.

Dieser Abgleich sollte nur vorgenommen werden, wenn die gemessene Spannung ausserhalb der angegebenen Toleranz liegt. Wenn ein Abgleich vorgenommen wurde, muss die Einstellung des Focus-Gain nach 4.2.5 ueberprueft werden.

**Achtung:**

Spannungswerte ueber 550mV verkuerzen die Lebensdauer des Laser-abtasters.

- Gerat ausschalten und Servo-2 PCB wieder einbauen.

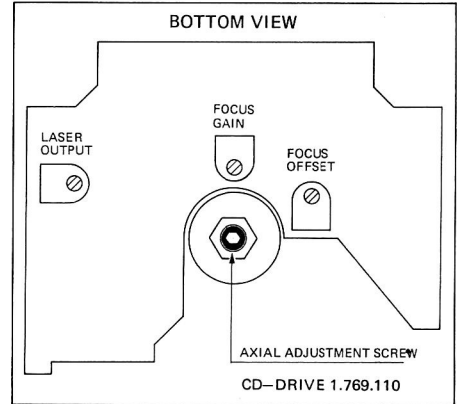

Fig. 4.13

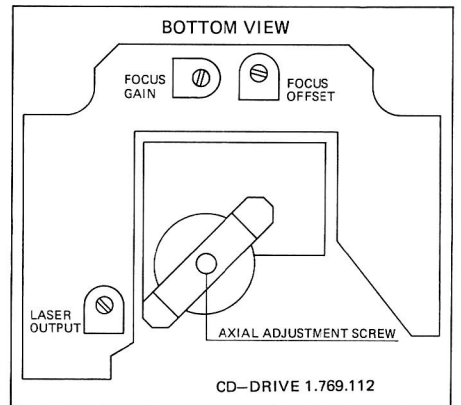

Fig. 4.14

**4.2.4 Symmetrie einstellen**

(Potentiometer FOCUS OFFSET, auf Laufwerk 1.769.110/112)

Die Symmetrie wird bei allen Laufwerken werkseitig eingestellt und sollte nicht veraendert werden.

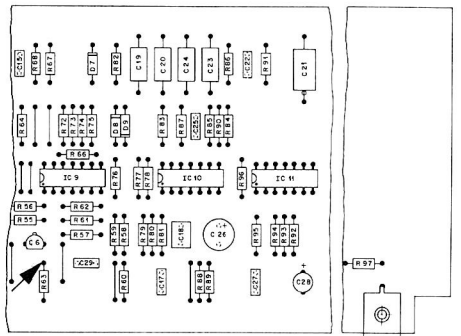

Fig. 4.15

**4.2.5 Fokus- Gain einstellen**

- Gerat ausschalten, Servo-1 PCB 1.769.315 ausbauen und ueber Serviceprint wieder einstecken.
- NF- Generator an X- Eingang eines Oszilloskopes und ueber ein R-C-R- Glied (gem.Fig. 4.16) an Pin 6 von IC2 (auf 1.769.310/315) anschliessen (f= 600Hz +/-5Hz, U= 250...300mV RMS).
- Mit Trimpotentiometer FOCUS GAIN (auf Laufwerk 1.769.100.35/.36) die Amplitude A der Lissajous-Figur auf ein Minimum abgleichen.

**Achtung:** Die Masse des NF- Generators ist unbedingt mit 0V oder dem Gerate- Chassis zu verbinden.

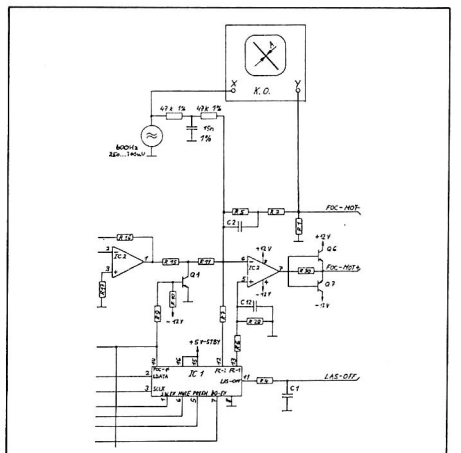

Fig. 4.16

#### 4.2.6 Kontrolle der Winkeleinstellung

- Geräet ausschalten und Schublade von Hand ca. drei-viertel ausfahren (beide hinteren Messingschrauben muessen durch die Offnungen im Bodenblech sichtbar sein, siehe Fig. 4.17).
- Die vier Laufwerkbehaftungsschrauben A loesen.
- Die Schublade ganz herausziehen, das Laufwerk vorne vorsichtig anheben und die Steckverbindungen zum Laufwerk trennen.
- Laufwerk aus der Schublade heben und die obere Kunststoffabdeckung abnehmen (zwei Kreuzschlitz-schrauben loesen).
- Den Spiegel auf die Laserlinse, und die Glas - CD (beides in Set Nr. 46242 enthalten) auf das Laufwerk legen.
- Das Laufwerk unter eine geradlinige Lichtquelle (z.B. Leuchtstoffroehre) stellen.
- Den Laser- Abtaster in Mittelstellung bringen und das Laufwerk so drehen, dass der Arm parallel zur Licht- quelle steht (siehe Fig. 4.18).
- Beim Betrachten der beiden Reflexionen der Licht- quelle in der Glas - CD und im Spiegel auf dem Abtaster (wie in Fig. 4.18) darf deren seitlicher Versatz nicht mehr als 2,5mm betragen.
- Laufwerk so aufstellen, dass die Lichtquelle einen 90°- Winkel zum Abtasterarm bildet (siehe Fig. 4.19).
- Der Abstand der beiden Reflexionen darf auch jetzt nicht groesser als 2,5mm sein.

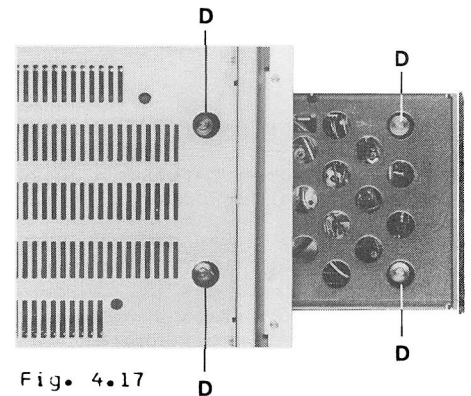

Fig. 4.17

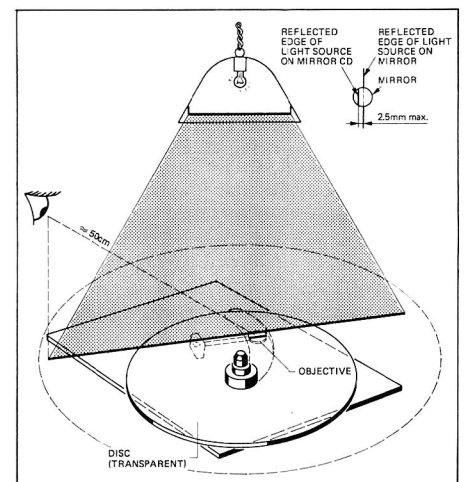

Fig. 4.18

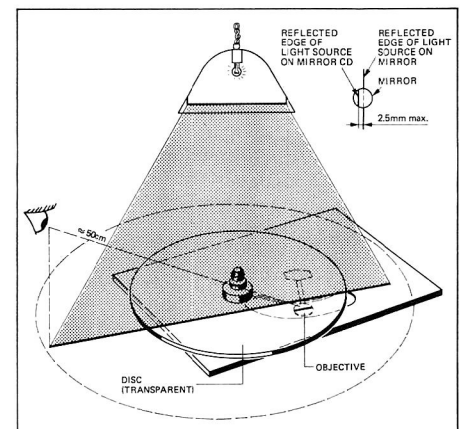

Fig. 4.19

Wenn die Abweichung zu gross ist, muss die Winkeleinstellung korrigiert werden:

- Mit Torx-Schlüssel Nr.8 Schrauben {A} loesen, bis sich die Lagerplatte {B} verschieben laesst.
- Die Lagerplatte kann nun gemass Fig. 4.20 verschoben werden. Bei korrekter Position Schrauben {A} wieder festdrehen.
- Nach diesen Einstellungen muss die Winkeleinstellung nochmals ueberprueft werden.
- Kunststoffabdeckung montieren und Laufwerk einbauen. Danach Kontrolle gemass 4.2.7 (DC-Komponente des Fokus- Signals einstellen).

#### 4.2.7 DC- Komponente des Fokus- Signals einstellen

- DC- Voltmeter an R1 (Servo 1- Print 1.769.315) anschliessen.

Der folgende Abgleich muss nur vorgenommen werden, wenn die DC- Abweichung grosser als  $\pm 140\text{mV}$  ist. Ist der Abgleich nicht moeglich, muss der Motor ersetzt werden.

- Achsial- Stellschraube des Disc- Motors so einstellen, dass  $0\text{V} \pm 50\text{mV}$  gemessen werden.
- Wird der Motor ersetzt, so muessen die Einstellungen gemass 4.2.6 und 4.2.7 durchgefuehrt werden.

#### 4.2.8 Spule L1 einstellen

Der folgende Abgleich muss nur vorgenommen werden, wenn eine neuengelegte Disc zeitweise nicht startet.

- Geraet ausschalten, Decoder PCB 1.769.300 ausbauen und ueber Serviceprint (Best. Nr. 46230) wieder einstecken.
- Digitalvoltmeter an Pin 18 von IC 13 anschliessen.
- Im Wiedergabebetrieb durch drehen des Abstimmkerns der Spule L1 eine Spannung von  $4,75\text{V DC}$  einstellen.
- Decoder PCB 1.769.300 wieder einbauen.

### 4.3 Messen der Audio- Daten

#### 4.3.1 Hilfsmittel

- CD- Testplatte Best. Nr. 46240
- autom. Klirrfaktormessbruecke (z.B. Tektronix AA 501 / fuer alle Messungen muss Taste RESPONSE auf Stellung RMS sein).
- Messfilter (fuer Klirrfaktormessung)
- Frequenzaehler
- Oszilloskop

#### 4.3.2 Klirrfaktor

- Messaufbau gem Fig. 4.21
- Mit der Taste VOLUME + maximaler Pegel einstellen
- Testplatte (Best. Nr. 46240) auflegen, fuer die Messung des linken Kanals Track 4 abspielen, fuer den rechten Kanal Track 8.
- Der Klirrfaktor muss kleiner als  $0,006\%$  sein.

#### 4.3.3 Ausgangspegel

- Taste CAL TONE druecken, mit Taste VOLUME + den maximalen Pegel einstellen.
- Die Ausgaenge FIXED und VARIABLE messen. Der Pegel muss  $2\text{V RMS} \pm 10\%$  betragen. Die Kanalgleichheit muss besser als  $0,2\text{dB}$  sein.

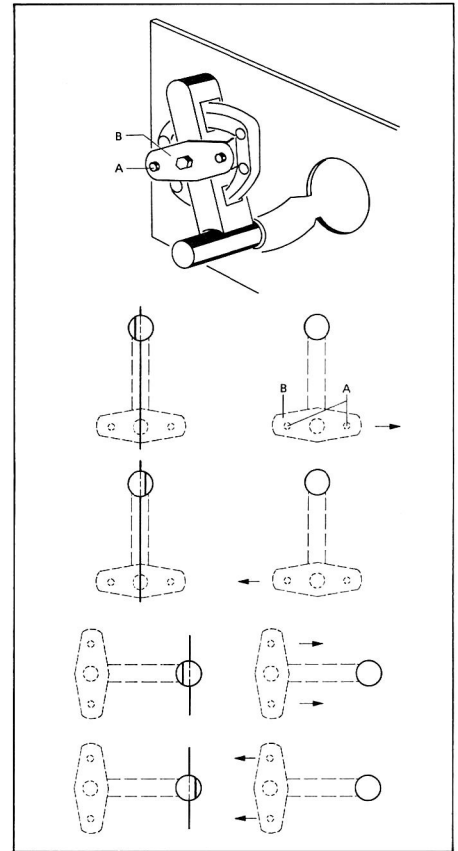

Fig. 4.20



Fig. 4.21

**4.3.4** Frequenzgang

- Mit Taste VOLUME + den Maximalpegel einstellen.
- Als Referenz 0dB gilt der Kalibrierton (1kHz).
- Track 4 und 8 (CD Best. Nr. 46240) abspielen und die Ausgaenge FIXED und VARIABLE messen. Der Frequenzgang muss innerhalb der Toleranz von +0 -0,6dB liegen.

**4.3.5** Uebersprechen

- Mit Taste VOLUME + den Maximalpegel einstellen.
- Referenz = CAL TONE 1000Hz
- Ueber ein 30kHz- Tiefpassfilter werden beide Ausgaenge gemessen:
- Track 8 fuer Messung Uebersprechen R zu L
- Track 4 fuer Messung Uebersprechen L zu R
- Die Uebersprechdaempfung muss mindestens 90dB betragen.

**4.3.6** Fremdspannungsabstand

- Volume auf Maximum, Referenz = CAL TONE 1000Hz.
- Track 18 abspielen und ueber ein 30kHz- Tiefpassfilter die Ausgaenge FIXED und VARIABLE messen.
- Der erreichte Wert muss ueber 96dB liegen.

**4.3.7** Geraeuschnennungsabstand

- Volumen auf Maximum, Referenz = CAL TONE 1000Hz.
- Track 18 abspielen und ueber ein A- Filter die Ausgaenge FIXED und VARIABLE messen.
- Der erreichte Wert muss ueber 100dB liegen.

**4.3.8** Phasenlinearitaet

- Oszilloskop an einem Ausgang anschliessen.
- Track 20 abspielen, und die Rechtecksignale bei 100Hz, 400Hz, 1002Hz und 5512Hz optisch beurteilen.
- Die Kurvenform muss symmetrisch sein (siehe Fig. 4.22).

**4.4** Akustische Beurteilung mit CD- Testplatte  
(Best. Nr.46241)

- Die CD- Testplatte enthaelt folgende simulierte Fehler, mit welchen das Fehlerkorrektursystem geprueft werden kann:
- Informationsunterbrueche von 400-900 Mikrometer (Track 5 bis Track 9)
  - Schwarze Punkte (Black Dots) von 300 bis 800 Mikrometer (Track 11 bis Track 17)
  - Simulierter Fingerabdruck (Track 18 und 19)

Die simulierten Defekte duerfen keine Drop Outs (Ausfaelle der Wiedergabe) verursachen. Falls trotzdem Drop Outs hoerbar werden, koennen beispielsweise folgende Fehler vorliegen:

- IC13 (SAA 7010, Demodulator), Clock- Regeneration mit PLL defekt.
- HFL- und DO- Detektor defekt.

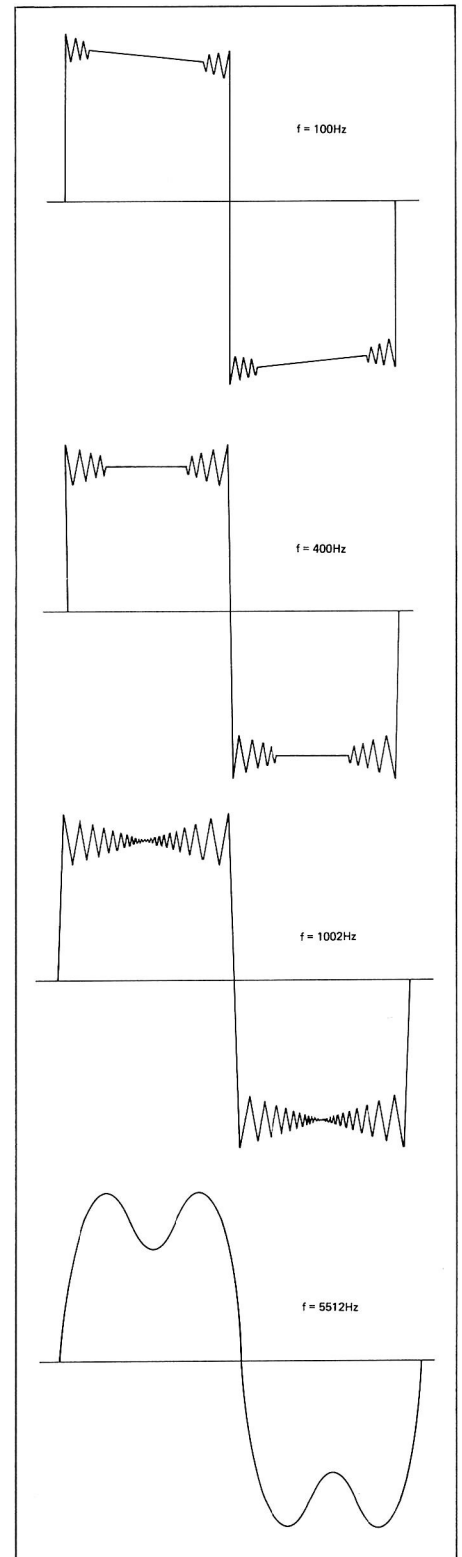

Fig. 4.22

TABLE OF CONTENTS		page
<b>1.</b>	<b>GENERAL</b>	
1.1	Index of CD player controls	1/1
1.1.1	General controls	1/1
1.1.2	Special controls	1/2
1.1.3	Rear panel connectors	1/3
<b>2.</b>	<b>REMOVAL OF ASSEMBLIES</b>	
2.1	Removing the top cover	2/1
2.2	Removing the side panels	2/1
2.3	Removing the individual circuit boards	2/1
2.4	Removing the player mechanism	2/1
2.4.1	Player mechanism 1.769.110	2/1
2.4.2	Player mechanism 1.769.112	2/2
2.5	Removing the display	2/2
2.6	Removing the power transformer	2/2
2.7	Removing the drawer motor	2/2
2.8	Removing the operating panel	2/3
2.9	Removing the guide rods	2/3
2.10	Exchange of the player mechanism	2/3
2.11	Reassembly	2/3
<b>3.</b>	<b>CIRCUIT DESCRIPTIONS</b>	
3.1	SERVO 1 PCB 1.769.310	3/1
3.1.1	Stabilization of the supply voltages	3/1
3.1.2	Drawer position detector	3/1
3.1.3	Focus control loop	3/2
3.1.4	Disc motor control loop	3/2
3.2	Microprocessor PCB 1.769.320	3/3
3.2.1	Microprocessor system	3/3
3.2.2	Drawer motor control	3/4
3.3	SERVO- 2 PCB 1.769.330	3/4
3.3.1	Radial control	3/4
3.3.2	Radial control circuit	3/4
3.3.3	Automatic gain control- (AGC-) circuit	3/5
3.3.4	Offset control circuit	3/5
3.3.5	Track detecting circuit	3/6
3.4	Preamplifier and laser PCB 1.769.100.35	3/6
3.4.1	Laser control	3/6
3.4.2	Focus and radial control signals	3/6
3.4.3	HF signal amplifier	3/6
3.5	Decoder PCB 1.769.300	3/6
3.5.1	Digital signal processing	3/7
3.5.2	Digital sine-wave generator	3/7
3.5.3	HFL and DDO detector	3/7
3.6	DAC PCB 1.769.280	3/7
3.6.1	Digital filtering (oversampling) and D/A conversion	3/7
3.6.2	Level adjustment and headphones amplifier	3/8

**4. TEST POINTS, ADJUSTMENTS ON B225**

4.1	Test points on B225	4/1
4.1.1	Test points on SERVO 1 PCB 1.769.310	4/1
4.1.2	Test points on SERVO 2 PCB 1.769.330	4/3
4.1.3	Test points on microprocessor PCB 1.769.320	4/4
4.1.4	Test points on decoder PCB 1.769.300	4/6
4.1.5	Test points on DAC- PCB 1.769.280	4/8
4.2	Adjustments on CD player B225	4/9
4.2.1	Aids	4/9
4.2.2	Aligning the player mechanism, general	4/9
4.2.3	Adjusting the laser current	4/9
4.2.4	Adjusting the balance	4/10
4.2.5	Adjusting the focus gain	4/10
4.2.6	Checking the angle alignment	4/11
4.2.7	Adjusting the DC component of the focus signal	4/12
4.2.8	Adjusting coil L1	4/12
4.3	Measuring the audio data	4/12
4.3.1	Aids	4/12
4.3.2	Harmonic distortion	4/12
4.3.3	Output level	4/12
4.3.4	Frequency response	4/12
4.3.5	Cross talk	4/13
4.3.6	Signal-to-noise ratio, linear	4/13
4.3.7	Signal-to-noise ratio, weighted	4/13
4.3.8	Phase linearity	4/13
4.4	Listening test with reference CD	4/13

**5. DIAGRAMS****6. SPARE PARTS****7. TECHNICAL APPENDIX**

7.1	Technical data	7/1
7.2	Dimensions	7/2

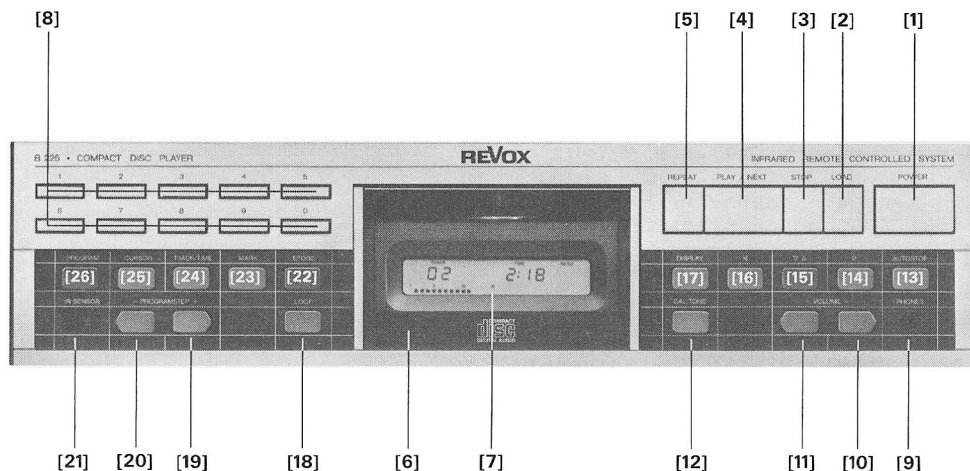
1. GENERAL1.1 Index of CD player controls1.1.1 General controls

- [1] POWER \* Key for switching the CD player ON and OFF. However, certain assemblies (such as the IR receiver) remain always switched on (in so-called standby mode).
- [2] LOAD The drawer with the player mechanism [6] opens or closes when this key is pressed.
- [3] STOP \* Interrupts the player function. The optical laser head is retracted to the starting position and the program is cancelled if the CD player was in program mode. The position in which the laser pickup was operating before STOP was pressed cannot be reproduced. If this is desired, please refer to ▼▲ (PAUSE) key.
- [4] PLAY/NEXT Play key with the following functions:  
If pressed after LOAD [2], the CD starts to rotate, the content list is read, and the disc is played starting at the first selection (TRACK). The next selection (TRACK) is accessed when this key is pressed again.  
If pressed after PROGRAM MODE [26] has been selected: play program mode is activated.
- [5] REPEAT The selection currently being played is repeated immediately when this key is pressed. If the CD player is in STOP mode, the first selection of the compact disc will be played. If the CD player is in program mode, the current program step will be repeated.
- [6] (CD drive) Drawer module with CD player mechanism and liquid-crystal display. The drawer can be opened or closed with LOAD [2].
- [7] (Display) Multifunction LC display which provides information on all operating modes of the CD player and the content of the loaded compact disc.
- [8] (keys 0-9) Digit keys for direct addressing of a selection (TRACK) in conjunction with PLAY/NEXT [4], or for programming.

The CD player can be switched on by pressing any of the controls [1] through [8] of the upper row (except REPEAT [5] and the digit key 0). The CD player starts in the selected operating mode.



### 1.1.2 Special controls

The controls in the lower front-panel section can be roughly divided into two function groups: controls for supplementary player functions, and programming controls.

#### A Controls for supplementary player functions

- [9] PHONES Headphones jack socket for headphones 200 to 600 ohms.
- [10] VOLUME + Increases the headphones level and the level of the VARIABLE OUTPUT.
- [11] VOLUME - Decreases the headphones level and the level of the VARIABLE OUTPUT
- [12] CAL TONE \* This calibration button connects a 1000 Hz calibration tone to the outputs so that the recording level of a connected tape deck can be accurately adjusted. The 1000 Hz CAL TONE corresponds to the maximum output level. This maximum level is system-dependent and will not be exceeded even by short peak pulses.
- [13] AUTOSTOP Interrupts the playing sequence at the end of the current selection or program step. The laser pickup is automatically positioned at the beginning of the next selection. The next selection is started immediately when PAUSE ▼▲ [15] is pressed. Upon conclusion of this selection, the CD player switches again to PAUSE mode.
- [14] Key ▶ Repositions the pickup from any location toward the end.
- [15] ▼▲ (pause)\* Interrupts the playing sequence at any time.
- [16] ◀ key Repositions the pickup from any location toward the start.
- [17] DISPLAY Switches over the display mode. The time elapsed since the start of the current selection is displayed in normal PLAY mode. The total play time from the start to the current selection can be displayed by pressing this key.

\* These functions can also be programmed.

#### B PROGRAMMING keys

- [18] LOOP \* Command key for repeating the CD or the program until STOP [3] is pressed.
- [19] + Forward "paging" in program mode. Particularly useful for modifying an existing program.
- [20] - Same function as [19] but backward paging.
- [21] IR SENSOR Infrared receiver window
- [22] STORE Memory load key to be pressed after each program step entry. The next program step is subsequently displayed so that the corresponding entries can be made.
- [23] MARK Allows a start and a stop mark to be set in programming mode while a selection is being played. Any CD location can thus be programmed.
- [24] TRACK/TIME Switches the display in programming mode from selection (track) input to time input (minutes and seconds).

- [25] CURSOR Any position on the display can be edited by approaching it with the cursor. NOTE: if the display is in TIME mode, the cursor must be advanced with this key in order to enter the seconds after the minutes.
- [26] PROGRAM Sets the program entry mode. If PLAY/NEXT [4] is pressed after the program entries have been completed, the CD player starts in PROGRAM mode.  
If the CD player is to be started in normal mode after the program entries have been completed, press the PROGRAM key [26] again before PLAY/NEXT [4].

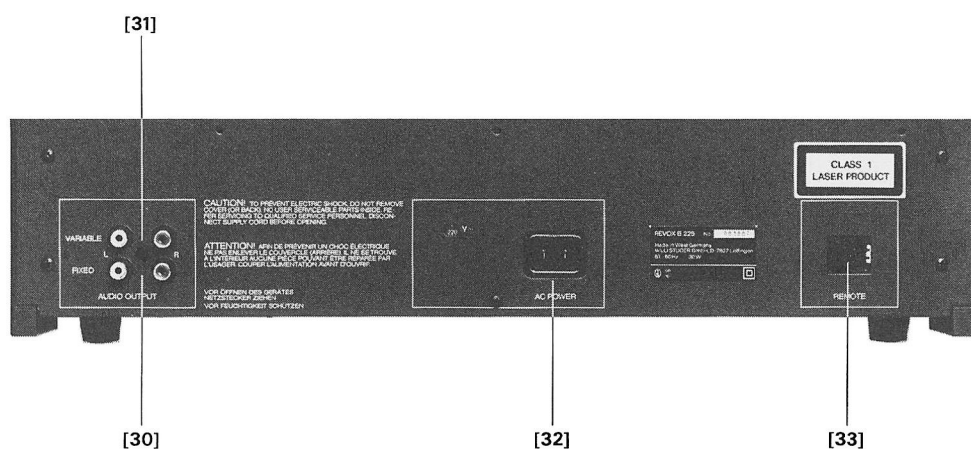

### 1.1.3 Rear-panel connectors

- [30] AUDIO OUTPUT FIXED. Output for connecting an amplifier on which the input can be matched to the level of the CD player (the REVOX B251 amplifier is ideally matched at the factory).
- [31] AUDIO OUTPUT VARIABLE. Active speakers or an output stage, etc. can be connected directly to this output. The volume can be adjusted with VOLUME + and - on the front panel of the CD player.
- [32] AC POWER. Power inlet (the setting of the line voltage selector can be checked adjacent to it).
- [33] REMOTE. This connector can be used for: a) disabling the IR receiver and b) connecting a cable-type remote control device.

## 2. REMOVAL OF ASSEMBLIES

### Important:

Disconnect the CD player from the AC supply before removing any parts of the housing. For certain work it is necessary to open or close the drawer module. This can be done manually without damaging the unit.

### 2.1 Removing the top cover

- Unfasten five screws [A] on the rear of the CD player.
- Withdraw cover toward the rear.

### 2.2 Removing the side panels

- Unfasten two screws on each side panel in order to remove them.

### 2.3 Removing the individual circuit boards

The circuit boards are accessible when the top cover is removed (Section 2.1).

The circuit boards 1.769.280 (DAC PCB), 1.769.300 (DECODER PCB), and 1.769.330 (SERVO 2 PCB) can be pulled out of the interconnection board after the fixing screws [B] have been unfastened.

Four connectors must be detached before the PCB 1.769.320 (MICROPROCESSOR) is removed. Then unfasten screw [B] and withdraw the PCB from the housing toward the rear.

The SERVO 1 PCB 1.769.315 is connected to the chassis via the cooling plate of the voltage regulators. First detach all connectors leading to this PCB. Push the drawer out completely in order to gain access to the three fixing screws. The three screws (C) can subsequently be unfastened and the PCB withdrawn toward the rear.

### 2.4 Removing the player mechanism

#### 2.4.1 Player mechanism No. 1.769.110

(Serial numbers up to 9523 and from 10236 up to 11187)

- Remove top cover (Section 2.1)
- Push drawer out part of the way and set the CD player upside down.
- Now pull the drawer out to the point where the screws [D] become accessible.
- Unfasten screw [D] and set the CD player again in its normal operating position on the bench (NOTE: hold the player mechanism with your hand to prevent it from falling out of the drawer).
- Pull drawer out completely and carefully lift the CD player.
- Detach the six connectors (see Fig. 2.5).
- The player mechanism can now be lifted out of the drawer.

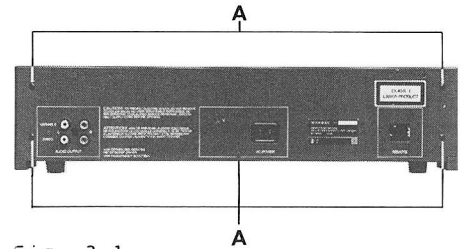

Fig. 2.1

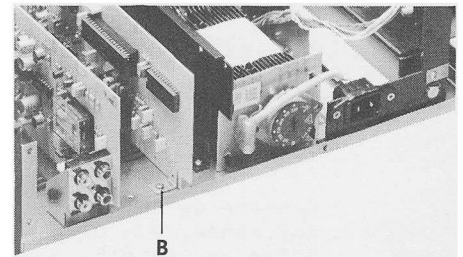

Fig. 2.2

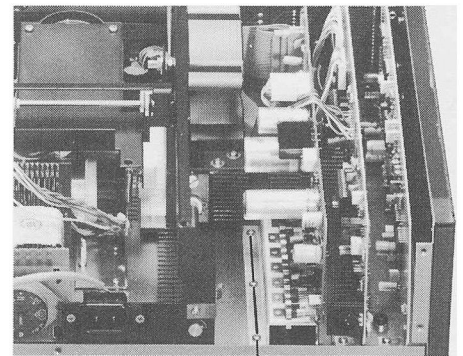

Fig. 2.3

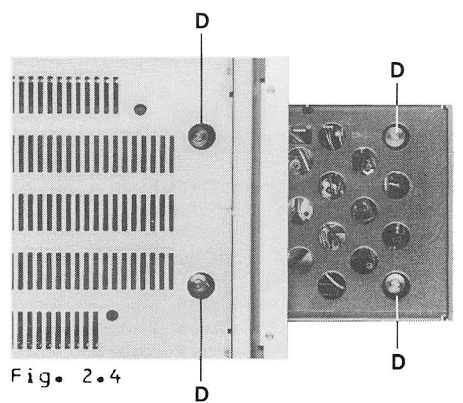

Fig. 2.4

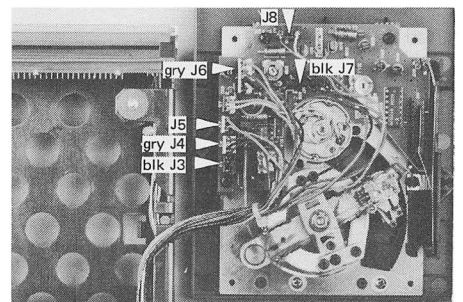

Fig. 2.5

#### 2.4.2 Player mechanism No. 1.769.112

(Serial numbers from 9524 up to 10235 and from 11188 onward)

- Removal: refer to 2.4.1
- Instead of six connectors only four have to be disconnected (see Fig. 2.6).

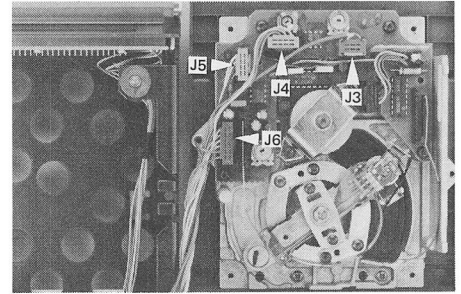

Fig. 2.6

#### 2.5 Removing the display

- Open the drawer and unfasten two screws [E] on each side.
- Unfasten cable clamp [F] and detach connector of cable harness. The display can now be lifted out by carefully sliding the cable harness out below the player mechanism.

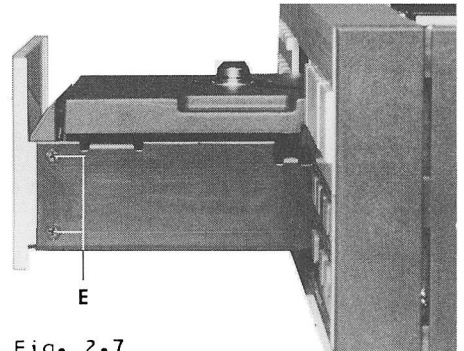

Fig. 2.7

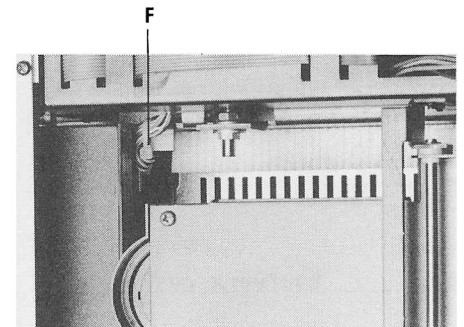

Fig. 2.8

#### 2.6 Removing the power transformer

- Remove top cover (see Section 2.1).
- Unfasten four screws [G] from the bottom.
- Detach the connectors of the power transformer to the SERVO 1 PCB 1.769.315, remove power inlet by unfastening the two screws and unfasten screw (H) (black cable, soldering tag).
- The transformer can now be removed.

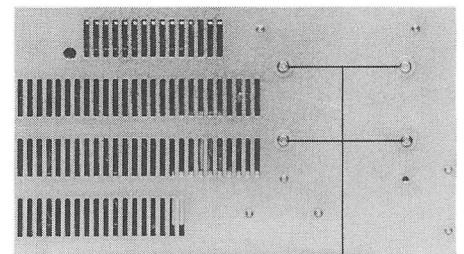

Fig. 2.9

#### 2.7 Removing the drawer motor

- Remove top cover (see Section 2.1).
- Remove power transformer (see Section 2.6).
- Unfasten three screws [H] from the top, unhook spring [I], detach connectors leading from the motor to the microprocessor PCB 1.769.320, and carefully lift out the motor.

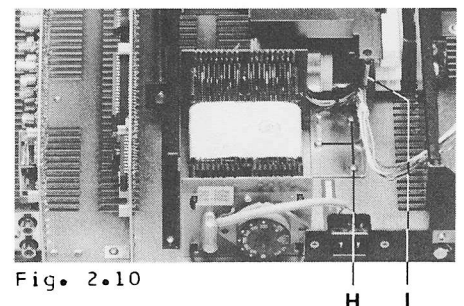

Fig. 2.10

H I

### 2.8 Removing the operating panel

- Remove top cover (Section 2.1) and side panels (Section 2.2).
- Unfasten four screws [K] each on the top and the bottom of the operating panel.
- Carefully withdraw operating panel from the chassis and detach the connectors.

### 2.9 Removing the guide rods

- Remove top cover (see Section 2.1).
- Unfasten the inner retaining ring [L]; the rod can now be pulled out of the unit from the rear.

Note: Do not lose the small O-ring that cushions the drawer stop.

Lubricate the guide rods slightly with special grease ISOFLEX TOPAS NB 52 before reinserting them.

### 2.10 Exchange of the player mechanism

- Remove player mechanism (see 2.4).
  - Previous player mechanisms were equipped with an Electronics PCB that is no longer available. On the new PCB different connectors are used. The plugs of the previous CONNECTION PCB 1.769.390-00/-81 have to be replaced by new ones (included in the new player mechanism). Cut the wires as close to the connectors as possible. The wire ends are to be placed into the new connectors without stripping the ends according to the table below; pin 1 is indicated on each plug. Then squeeze the connector until the notches engage.
- After inserting the plugs on the player mechanism PCB, the new one can be reinstalled.

colour	1.769.110	1.769.112
blk	J6/1	J5/1
brn	J6/2	J5/2
red	J6/3	J5/3
gry	J6/4	J5/4
blk	J7/1	J4/1
brn	J7/2	J4/2
red	J7/3	J4/3
gry	J7/4	J4/4
yel	J5/1	J6/1
grn	J5/2	J6/2
blk	J4/1	J6/3
brn	J4/2	J6/4
blk	J3/1	J6/5
brn	J3/2	J6/6
wht	J8/1	J3/1
n.c.	J8/2	J3/2
scr.	J8/3	J3/3

### 2.11 Reassembly

The CD player is reassembled by following the dismantling steps in the reverse order. It is absolutely essential to secure the cable harness in the drawer with a clip as illustrated in Fig. 2.8.

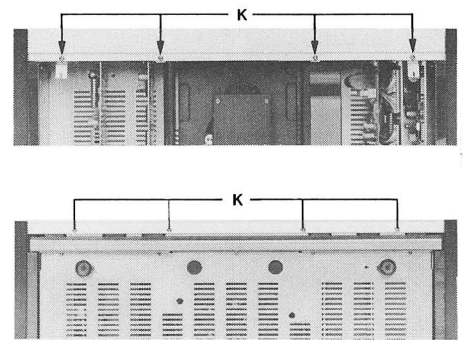

Fig. 2.11

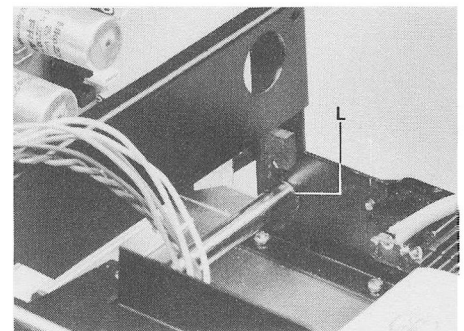

Fig. 2.12

### 3. CIRCUIT DESCRIPTIONS

#### 3.1 SERVO 1 PCB 1.769.310/315

The following circuits are implemented on the SERVO 1 PCB:

- Stabilization of the supply voltages
- Drawer position detector
- Focus control loop
- Disc motor control loop
- On the Servo 1 PCB 1.769.315, in contrast to 1.769.310, the components Q 13, C 31, R60 and R 61 are not installed.
- Modification of 1.769.310 to 1.769.315 is recommended. Only unsoldering of capacitor C 31 is required (Fig. 3.3).

##### 3.1.1 Stabilization of the supply voltages

All supply voltages are stabilized by voltage controllers (IC 4 to IC 9, LM317/LM337).

The +5V supply (+5 V STBY) is always available. It supplies the microprocessor system and the IR receiver even when the CD player is switched off (standby). The remaining supply voltages are switched on or off by the microprocessor with the PS-OFF signal. When the CD player is switched off, PS-OFF becomes "H" (+5 V) and transistors Q9 and Q10 become conductive (saturated), causing the +5 V and +12 V supply voltages to drop to a residual voltage of 1.3 V. The -7 V supply is switched off through the circuit R38, R39, and Q8; the -12 V supply via R52, R54, and Q11; and the -17 V supply via R51, R53, and Q12. This prevents the positive supply voltages from becoming negative. The voltage is doubled through diodes D15, D16, D17 and capacitors C29, C30, and taken to the voltage controller IC9 for the -17 V supply. D18 protects the controller from an excessive direct-axis component of the voltage.

##### 3.1.2 Drawer position detector

The two light barriers DLQ1 and DLQ2 (on PCB 1.769.310) check whether the drawer is open or closed. The corresponding signals indicate the following conditions:

<u>Position</u>	<u>DRA-POS-B</u>	<u>DRA-POS-F</u>
closed	L	L
half way	H	L
open	H	H

L = 0 V  
H = +5 V

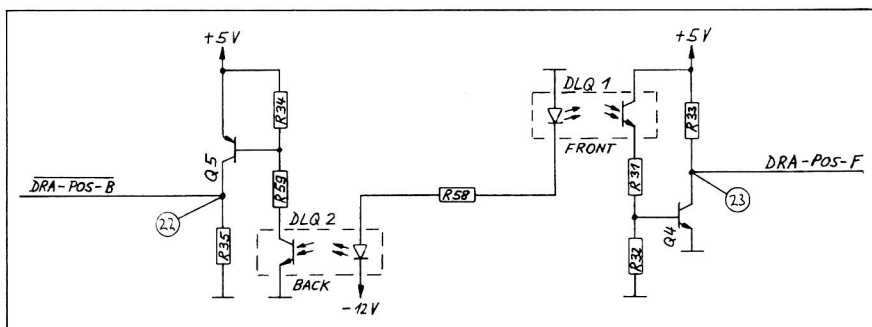

Fig. 3.1

3.1.3 Focus control loop

The lens can be moved vertically and is designed similar to the mechanical system of a speaker. The coil is stationary and the magnet moves. The focus error signal FOC-ERR is first amplified (lead amplifier IC2a, R3, R12, R16, R17, C3, C4) and subsequently taken to the controlling amplifier ("lag" amplifier R1, R2, R5, R11, R15, R29, R30, C2, C12, IC2b, Q6, Q7 and the impedance of the lens coil). In STOP mode, the control loop is interrupted via Q1 by the signal FOC-0 (= H) which means that no unnecessary power is consumed by the output amplifier (Q6 and Q7).

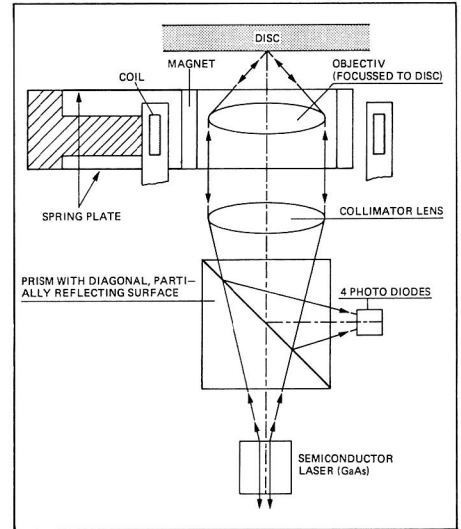

Fig. 3.2

The start-up circuit (IC1, R6, R7) adjusts the focussing to the reflective layer of the compact disc. The signals FC-1 and FC-2 are alternately switched to "H", causing the lens to move alternately up or down. Once the correct focus has been found, the signal FOC-NEG briefly drops to "L". The microprocessor then enables the focus control loop (FOC-0, FC-1, and FC-2 = "L").

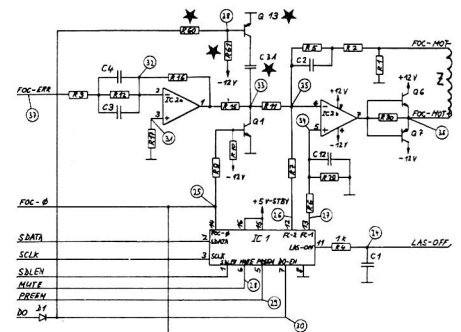

Fig. 3.3 \*not used for 1.769.315

3.1.4 Disc motor control loop

The data from the compact disc must be supplied as steadily as possible to the digital signal processing circuit. The speed with which these data (bits) arrive depends on the position of the laser pick-up (constant peripheral speed between 1.2 and 1.4 m/s). If the laser pick-up reads in the middle of the CD, the speed is much higher than near the edge. The speed correction signal MCES is generated in the error correction IC (SAA 7020 on PCB 1.769.300).

The signal MCES is switched off or on via the signal FOC-0 (R15, R16, IC3b on PCB 1.769.330). The signal is first filtered via a 2nd order low pass (R22, R23, R25, R26, R28, C10, C11, IC3b). The "lead network" is formed by C9, R19, R21, R24, and R28, the "lag network" by IC3a, C6, C7, R8, Q2, and Q3. As soon as the focal point has been found, the signal FOC-0 changes to "LOW" and the signal MCES is enabled. A negative pulse via C5 is simultaneously triggered on IC3a, pin 3, thereby fully driving transistor Q3 in order to rapidly accelerate the compact disc. The speed is subsequently controlled by the MCES signal.

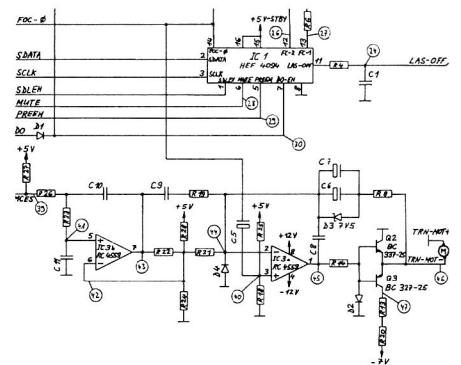

Fig. 3.4

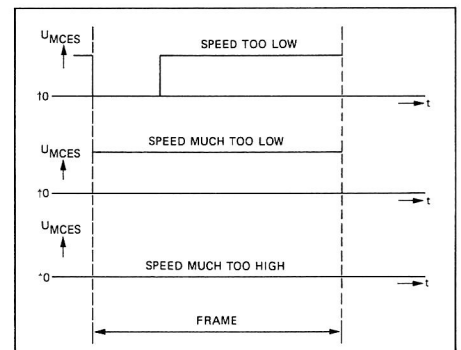

Fig. 3.5



### 3.2 Microprocessor PCB 1.769.320

The microprocessor system and the drawer control are implemented on the microprocessor PCB 1.769.320.

#### 3.2.1 Microprocessor system

The master microprocessor (M- $\mu$ P, IC2) scans the keyboard (P00 to P05, P10 to P14). The microprocessor system is reset when the LOAD key is pressed. To enable differentiation between a power failure and a LOAD command, P15 of the master processor is also pulled to "L" in conjunction with a LOAD command. Capacitor C12 latches this condition until P15 is read. This unconventional circuit arrangement offers the advantage that a RESET command can be initiated at any time by pressing the LOAD key in the event that the system becomes blocked for any reason.

The commands from the IR receiver or the REMOTE socket are read through the interrupt input of the master processor. When a command arrives from the IR remote control, the IR-REC signal is switched to "LOW" for approximately one second, causing the LED in the IR receiver window to turn on (command acknowledgment). The signals ~~DRA-POS-B~~ and DRA-POS-F supply the processor with drawer position information.

The signals CLK, DATA, DLEN-1, and DLEN-2 control the two LCD drivers PCE 2111 (on PCB 1.769.250). The gain of the headphones amplifier and the VARIABLE OUTPUT is controlled by the signals CLK, DATA, and DLEN-3 (on PCB 1.769.280).

The slave microprocessor (S- $\mu$ P, IC4) processes the subcode (supplementary information on the compact disk such as track, time, etc.). The required signals originate from PCB 1.769.300 (IC13, SAA 7010, signals Q-SYNC, SWCLK, Q-DATA, and P-BIT). The signals RC-0 and ~~RC-0~~ switch the radial-control loop on or off. When the radial control loop is switched off (~~RC-0~~ = L), the laser pick-up can be repositioned with the signals RCl, RC2, CUR-SUM, and CUR-DIR. The track signal (TRK) is read through the interrupt input of the slave processor. This signal changes to "L" as soon as the laser pick-up passes over a track. The direction in which the laser pick-up moves is reported to the slave processor by the signal T1. This signal also changes to "L" as soon as the laser pick-up passes over a track. It is also used in search mode for counting the tracks. Because the counting speed of the microprocessor is not high enough, only every other track is counted in fast search mode (division by 2, IC6b). Any program entered through the keyboard is stored serially in IC5 (serial RAM). Both microprocessors are initialized by IC1 (reset chip TL 7705). The +5 V STBY supply is supervised by IC1 via pin 7. A reset is also initiated via R1, R8, and C8 when the LOAD key is pressed. Commands from a cable-type remote control can be read through the REMOTE socket (pin 2 and pin 3). These commands are electrically isolated through the optocoupler IC 12a. These signals are converted to TTL signals by the comparator circuit (IC9a, R44, R45, R48, and R60). In order to disable the commands from the infrared receiver, the voltage at pin 4 must be higher than on pin 2 by +5 V. The +5 V STBY of the REMOTE socket can be used for this purpose (interconnect pins 1 and 2, pins 4 and 5). The IR signal is thus short-circuited via DLQ2, R41, R42, R43, R62, and IC9b.



### 3.2.2 Drawer motor control

The drawer motor amplifier (IC10a, R52,53,56,57, and R58, C14, Q8 and Q9) is controlled through the shift register IC3 (pins 4 and 5). If the drawer movement is blocked during the opening or closing operation, the motor current rises and hence the voltage across R64. Signal T1 of the master processor consequently changes to "L" (circuit R40,54,55,59,63, Q6, Q7, C13, and IC10b). In response the master processor reverses the direction of the drawer movement.

### 3.3 SERVO-2 PCB 1.769.330

The SERVO 2 PCB 1.769.330 contains the circuits for radial control and the IR receiver.

#### 3.3.1 Radial control

A moving arm allows the laser pick-up to follow the track horizontally. This arm basically functions like a moving coil instrument.

The radial-control circuit can be subdivided into four blocks:

- Radial control circuit
- AGC circuit
- Offset control circuit
- Track detection circuit

#### 3.3.2 Radial-control circuit

The value of the radial-error signal can be computed as follows:  $RE = kd (I1 + I2 + I3 + I4) - k (I1 + I2)$ . The value of k is determined by the AGC circuit, and d by the offset control circuit.

$$RAD-ERR2 = I1 + I2$$

$$RAD-ERR1 = I3 + I4$$

The signals RAD-ERR1 and RAD-ERR2 are summed via the circuit IC9b, R58/59/61/62/63 and Q6. The sum flows as a current through R63 and Q6. The error signal RAD-ERR 2 is converted via R55 and R57 to a current that flows through R54 and transistor E of IC8. The factor k is formed by transistors A and B as well as C and D (IC8), factor d is formed by Q5 and transistor F (IC8).

The signal  $RAD-ERR 2 \times k (=k [I1 + I2])$  on pin 10 of IC9c appears on pin 9 of IC9c; the signal  $[RAD-ERR1 + RAD-ERR2] kd (= kd [I1 + I2 + I3 + I4])$  appears on pin 10 of IC9c. The difference signal (RE), developed in IC9c, appears on Pin 8 ( $RE = kd [I1 + I2 + I3 + I4] - K[I1 + I2]$ ). The "lag" network of the radial control is implemented by R66, R67, R68, C15, and IC9d, the "lead" network by R69, R70, and C16. The signal is conducted to IC5 through the protective diodes D5 and D6. The signal is taken through switch B (IC5) to pin 2 of IC2 which together with Q2, Q3, R6, R7, R8, RT1, and C5 constitutes the output stage for the radial-control signal RAD-MOT+/RAD-MOT-. RT1 protects the coil. The control can be disabled (Signal RC-0). This occurs in search, pause, forward and reverse mode. The laser pick-up can be positioned during this phase with the signals RC-1, RC-2, CUR-DIR, and CUR-SUM.

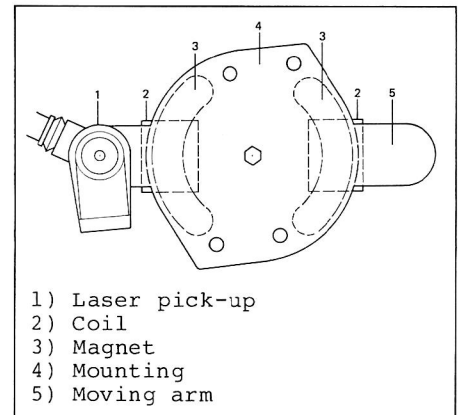

Fig. 3.6

3.3.3 Automatic gain control (AGC) circuit

The bandwidth of the radial-control circuit is stabilized by this circuit. A 650 Hz sine-wave signal is generated in the circuit IC10c, IC11d, C22, C23, C24, C25, R85, R86, R87, R90, and R91. As the gain increases or decreases the phase relation of the supplied signal becomes also larger or smaller with respect to the returning signal. The two signals are compared in the phase detector (IC11) and a new signal is developed. The latter is proportional to the phase and also to the gain. This signal controls the factor k. The gain is laid out for a phase shift between the signals of  $-135^\circ$ . The 650 Hz sine-wave signal is therefore fed into the control loop at pin 13 of IC9d through a  $45^\circ$  phase shifter (R84, C21). The phase shift is  $90^\circ$  at the input of the phase detector. The 650 Hz sine-wave signal is eliminated from the control circuit through a bandpass (IC10d, R82, R83, C19, C20) and converted in IC11a to a square-wave signal. This square-wave signal is input to the phase comparator (IC11c, pin 8). The phase reference is supplied by pin 9 of IC11c.

3.3.4 Offset control circuit

The asymmetry of the reflected laser beam is corrected by this circuit to ensure that the laser beam is kept exactly on the center of the track. The difference between minimum and maximum reflection is the greatest (presence of pit = minimum reflection, between pits = maximum reflection) when the laser beam follows exactly the center of the track.

Through the 650 Hz sine-wave signal the moving arm oscillates with an amplitude of  $0.05 \mu\text{m}$ . If the laser beam is on the track center, all half-waves of the filtered out signal are folded to the same (positive) side. If the laser beam is to the right of the track center, the signal is in-phase with the 650 Hz oscillations of the moving arm, or antiphase if the beam is on the left of the track center.

The voltage across R63 is proportional to the reflected light intensity ( $I_1+I_2+I_3+I_4$ ). The voltage is amplified through IC6a, R30, R31, and R64, and the 650 Hz component is filtered out in a bandpass (R32, R33, R34, R35, R37, C11, C12, and IC7b). The filtered signal is inverted through IC7a, R36, and R38. The former and the noninverted signal are taken to switch C of IC5. The output of this switch (IC5, pin 4) is integrated through IC7d and C30 and determines the factor d (Q5 and transistor F of IC8). The status of switch C (IC5) is controlled by the 650 Hz signal in the control loop via the bandpass R42, R43, R44, R45, C13, C14, D4, and IC7c.

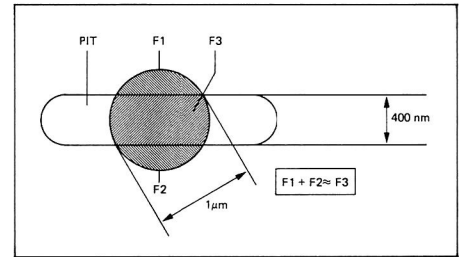

Fig. 3.7

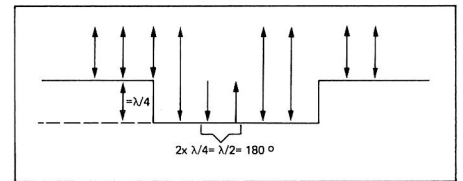

Fig. 3.8

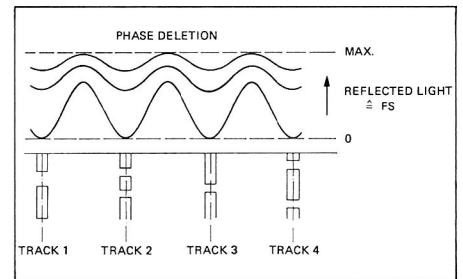

Fig. 3.9

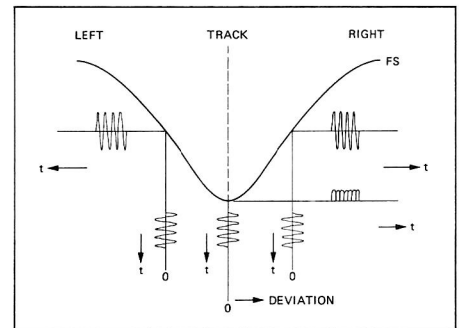

Fig. 3.10

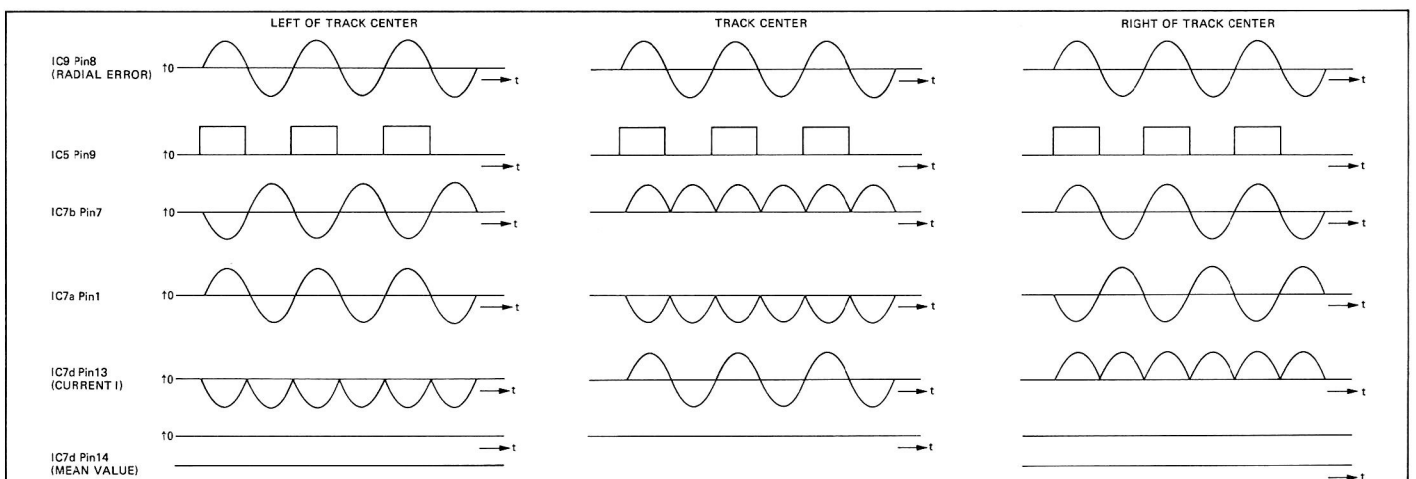

Fig. 3.11

### 3.3.5 Track detection circuit

The tracks which are skimmed over by the laser pick-up are read through the interrupt input of the slave processor (TRK-SIG). This signal is generated from the signal available at IC6, pin 1 (proportional to  $[I1+I2+I3+I4]$ ), the DO and the HFL signal. The signal DO is "L" when no error location is detected on the CD.

The HFL signal is "H" when the HF signal is large enough. The TRK signal is only "L" when the HF signal is too small. For each skipped track, HFL is "L" if no error location is detected on the CD (DO="L"). The radial-error signal RE (IC9c, pin 8) informs whether the laser scanner is positioned to the left or the right of the track. The signal required for this purpose (RAD-POS) is generated via IC3c, R12, R19, and R20 from the radial-error signal.

### 3.4 Preamplifier and laser PCB (on the player mechanism)

This board comprises the following circuits:

- Laser control
- Signal for focus and radial control
- HF signal amplifier

#### 3.4.1 Laser control

The laser diode is supplied via transistor BD 226. The laser light is checked via the monitor photo diode and adjustable with the trimmer potentiometer LASER OUTPUT. The LAS-OFF signal (from PCB 1.769.315 / IC1) switches the laser on or off.

#### 3.4.2 Focus and radial-control signals

The following signals are generated by this circuit:

- FOC-ERR
- RAD-ERR1
- RAD-ERR2

The currents of the four photodiodes (A1 to A2) are amplified in IC NE5514. The corresponding error signals are generated by the subsequent network. The focus error signal is proportional to  $(I1 + I4) - (I2 + I3)$ .  $I3 + I4$  form the RAD-ERR1 signal,  $I1 + I2$  the RAD-ERR2 signal. With FOCUS GAIN potentiometer, the amplification of the focus circuit can be adjusted and the balance with FOCUS OFFSET.

#### 3.4.3 HF signal amplifier

The circuit comprising transistors Q1 through Q7 constitutes the signal amplifier with bandpass characteristic. Low-frequency (e.g. control signals of the servos) and high-frequency disturbance signals are consequently filtered out.

### 3.5 Decoder PCB 1.769.300

The decoder PCB contains the following circuits:

- Digital signal processing
- Digital sine-wave generator
- HFL and DO detector

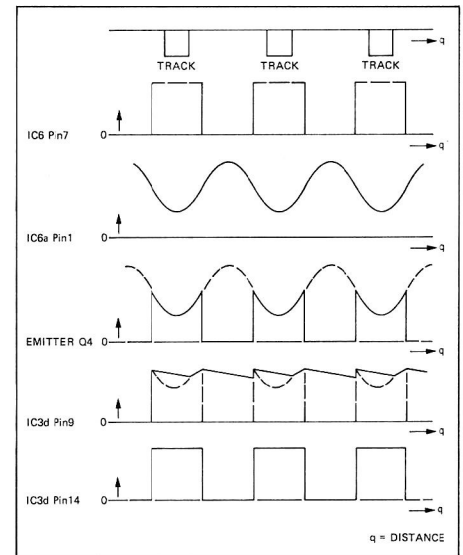

Fig. 3.12

### 3.5.1 Digital signal processing

The HF signal is converted in IC13 (SAA 7010) into digital signals and split into audio and information data (subcode, for the slave processor). The CLOCK signal is also regenerated in IC13. The audio data are brought into the correct time slot pattern. Corrupted audio data are not recognized in IC12 and corrected if necessary. Should the errors be incorrigible, the missing sample values are replaced in IC10 (SAA 7000) through interpolation. Should this also be infeasible, the HF signal is slowly muted (soft muting). The speed of the CD motor is controlled by the signal MCEs (IC1, pin 4).

### 3.5.2 Digital sine-wave generator

The PROM (IC4) contains a value table for the sine-wave signal which represents the maximum possible level of a CD.

The circuit consists of IC5 through IC9 with IC5 and IC6 supplying the addresses for the PROM. Parallel/serial data conversion is performed in IC3. The change-over between audio data from the CD and the 1 kHz sine-wave signal is controlled by IC1.

### 3.5.3 HFL and DO detector

The HF signal is fed into the inverting differential amplifier Q1 and Q2 through C6 and R2. The output signals are DC-decoupled via C8 and C9 respectively and tied to DC ground via D2 and D3. D4 and D5 or D6 and D7 respectively constitute a full-wave rectifier each through which the capacitors C10 or C11 are charged. With a normal HF signal the DO signal is "L" and the HFL signal is "H". If the HF signal drops to approximately 70% of the normal value, the HFL signal also changes to "L". Only when the HF signal drops to approximately 10% of the normal value does the DO signal change to "H".

To prevent the output signals of IC11 from being influenced too strongly by minor contaminations (e.g. fingerprints) on the CD, transistor Q3 has been added to the output. When the RF level is at nominal value, pin 7 of IC11 is "H". Q3 becomes conductive and the circuit with C11 receives a smaller time constant. With level fluctuations caused by minor contaminations, the levels of the two input capacitors fluctuate in parallel, but neither the DO nor the HFL signal are affected.

## 3.6 DAC PCB 1.769.280

The following circuits are implemented on this PCB:

- Digital filtering (oversampling) and digital/analog conversion
- Level adjustment and headphones amplifier

### 3.6.1 Digital filtering (oversampling) and D/A conversion

IC1 (SAA 7030) contains two identical filters for both channels. These filters feature 3 sections:

- Oversampling section
- Transversal digital filter
- Noise shaper

After each scanning cycle, the new sample values are inserted by interpolation into the 16-bit information arriving from the decoder. The scanning rate thus becomes 4 times greater ( $4 \times 44.1 \text{ kHz} = 176.4 \text{ kHz}$ ). The spectral lines above 20 kHz up to 176.4 kHz - 20 kHz are filtered out by the transversal filter. The sample values are truncated to 14 bits. The noise shaper subsequently delays the truncation error by the scan duration and negatively added to the next sample value. The quantizing noise caused by truncation is thereby largely shifted toward the frequency range above 20 kHz. The digital signal is converted in IC101 or IC201 (TDA 1540) to an analog signal. In order to filter out the residual frequency component at  $n (176.4 \text{ kHz} + 20 \text{ kHz})$ , a low pass of the third order (Bessel filter) has been added to the converter output.

The preemphasis is corrected with the circuit illustrated in Fig. 3.13. The subcode on the CD specifies whether the selection was recorded with or without preemphasis. The characteristic of the corresponding filter can be adjusted with the PREEM signal.

### 3.6.2 Level adjustment and headphones amplifier

The volume is controlled by a DUAL D/A converter (AD7528). It serves as an attenuator before the corresponding input (IC103a, pin 2 = left-hand channel / IC 203b, pin 6 = right-hand channel). The negative-feedback resistances of both opamps remain unchanged which means that the level can only be attenuated with this circuit. The dual D/A converter is controlled by a CMOS shift register through the signals DLEN-3, DATA, and CLK. The circuit illustrated in Fig. 3.14 constitutes the output amplifier for the headphones socket and also the VARIABLE OUTPUT. The signal is also attenuated for this purpose through a voltage divider so that the signal is the same (2 V RMS) at both outputs (FIXED and VARIABLE). The signal is taken through relay K1 in order to prevent power-on switching clicks. When power is applied, the relay is selected by the KILL signal (which rises to +5 V after approximately 1 to 2 seconds). As a result, the outputs are only through-connected when the supply voltages are stable.

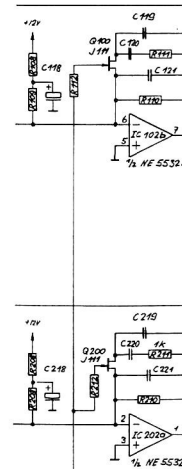

Fig. 3.13

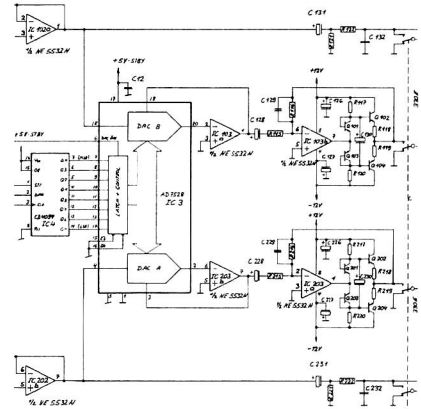

Fig. 3.14

4. TEST POINTS, ADJUSTMENTS ON B225

4.1 Test points on B225

4.1.1 Test points on SERVO 1 PCB 1.769.310

TP	POWER-ON	POWER-OFF
1	+5V +/-5%	+5V +/-5%
2	+5V +/-5%	+1.3V
3	-7V +/-5%	-1.3V
4	+12V +/-5%	+1.3V
5	-12V +/-5%	-1.3V
6	-17V +/-5%	-1.3V

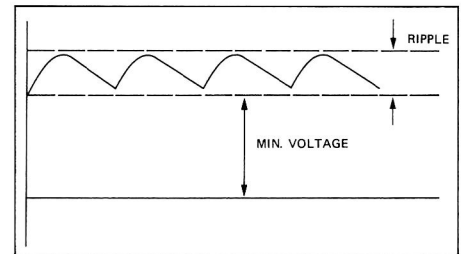

Fig. 4.1

TP	POWER-ON		POWER-OFF	
	Vmin.	Ripple	Vmin.	Ripple
7	+12V	0.8V	+13.5V	0.3V
8	-14V	0.3V	-15V	0.1V
9	+18V	0.8V	+21V	0.2V
10	-18V	0.8V	-21V	0.2V
11	-27V	3.4V	-38V	0.9V

TP 7 to TP11, also refer to Fig. 4.1

TP	POWER-ON	POWER-OFF
12	0V	+5V
13	0V	+0.7V
14	+1.6V	-0.7V
15	0V	+0.7V
16	+6.5V	-0.7V
17	+6.5V	-0.7V
18	14V	15V
19	14V	15V
20	20V	22V
21	20V	22V

TP18 to TP21, also refer to Fig. 4.2

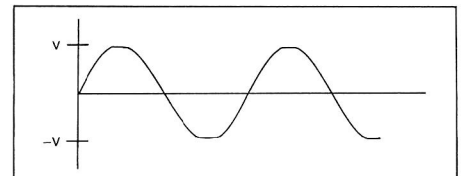

Fig. 4.2

TP	Drawer position		
	closed	half way	open
22	0V	+5V	+5V
23	0V	0V	+5V

TP	PLAY- Mode	STOP- Mode	TP	PLAY- Mode	PAUSE/SEARCH
24	0V	+5V	28	+5V	0V
25	0V	+5V			
26	0V	0V			
27	0V	0V			

If no CD is mounted when PLAY is selected, the signals on TP26 and 27 become +5V in four intervals of approximately one second each.

TP	Preemphasis	TP	PLAY- Mode	SEARCH
	yes   no	30	+5V	0V
29	+5V   0V			

TP	PLAY- Mode	STOP- Mode	TP	PLAY- Mode	SEARCH
31	0V	0V	38	2.6V	-0.7V
32	0V	0V			
33	0V (*)	0V			
34	0V	0V			
35	0V (*)	0V			
36	0V (*)	0V			
37	0V (*)	0V			

(\*) In PLAY- mode, the signal pattern of these test points depends on the wobble of the mounted compact disc.

TP	PLAY- Mode	STOP- Mode	
39	7.5kHz (a)	0V	(a) = TTL- square-wave signal
40	+2.5V	+2.5V	
41	+2.7V	+0.1V	
42	+2.7V	+0.6V	
43	~2Vpp (b)	-11V	(b) = Control signal
44	+2.5V	+0.6V	
45	-2.8V (c)	+8.2V	(c) = Control signal, 0.8V superposed
46	- 2V (c)	0V	
47	-6.5V (d)	- 7V	(d) = Control signal, 0.3V superposed

4.1.2 Test points on SERVO 2 PCB 1.769.330

TP	STOP- Mode	PLAY- Mode	
1	0V	-1V	
2	0V	-1V	
3	0V	0V	
4	0V	0V	
5	0V	+0.6V	
6	0V	+0.3V	
7	0V	+4.4V	
8	0V	~2Vpp	(see Fig. 4.3 D)
9	0V	~2Vpp	(see Fig. 4.3 D)
10	0V	~2Vpp	(see Fig. 4.3 B)
11	0V	~2Vpp	(see Fig. 4.3 A)
12	+0.1V	0V	
13	-12V	~+6V	
14	0V	650Hz TTL	(Square wave, see Fig. 4.3 C)
15	+9.5V	+3.4V	
16	+9.5V	+3.4V	
17	0V	1Vpp 650Hz	(sine)
18	0.4Vpp 0.2V DC	0.6Vpp	(sine 650Hz)
19	0V	+5V	
20	+5V	0V	
21	+5V	0V	Search mode: intermittent +5V
22	0V	0V	pulses up to +1V
23	0V	0V	pulses up to +5V
24	0V	0V	pulses up to +5V
25	+0.1V	0V	
26	+0.1V	0V	
27	+1V	4Vpp 650Hz sine	
28	9Vpp 650Hz sine, 3VDC	9Vpp 650Hz sine, 3VDC	
29	650Hz TTL	650Hz TTL	(Square wave, see Fig. 4.3 E)
30	650Hz TTL see Fig.F	650Hz TTL see Fig.H	
31	+9.7V	+8.7V	
32	+2.5V	+2.5V	
33	1300Hz TTL (Fig. G)	1300Hz TTL (Fig. I)	(Square wave)

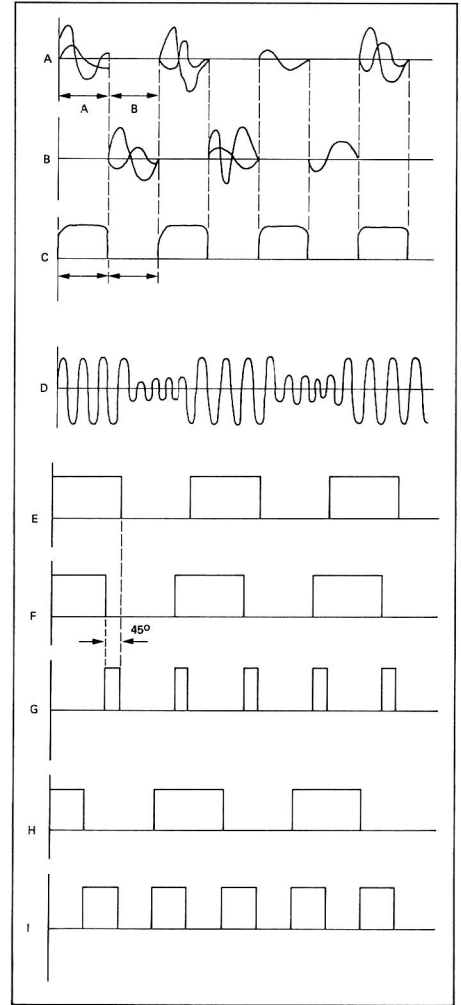

Fig. 4.3



34	+10.5V	-4V	
35	+2.5V	+2.5V	
36	+5V	+4.9V	
37	+5V (e)	+5V	(e) = The signal on TP37 briefly drops to 0V during the change-over from STOP to PLAY
38	650Hz TTL squ. wave	650Hz TTL squ. wave	
39	+0.8V	0V	search mode:-----+ 0V
40	+0.2V	+5V	alternating 0V/5V
41	0V	+5V	alternating 0V/5V
42	+5V	0V	alternating 0V/5V
43	0V	+5V	alternating 0V/5V
44	+3.7V	+3.7 V	alternating 4V/8V
45	0V	+4.2V	alternating 3V/6V
46	0V	+3.5V	alternating 3.2V/ 5.6V
47	0V	+4.8V	

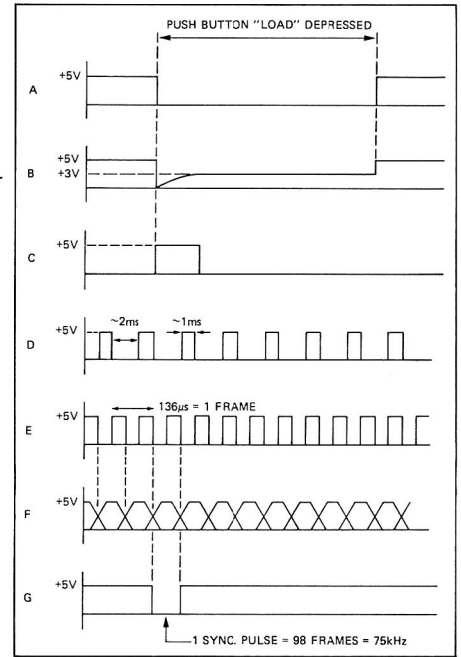

Fig. 4.4

TP	POWER-OFF	POWER-ON
48	+4.3V	+5V
49	+5V	0V
50	+5V	+5V
51	+0.4V	+0.4V
52	+0.3V	+0.3V

when signals are received from the IR- remote control, pulses of +4.3V occur on TP52.

4.1.3 Test points on MICROPROCESSOR PCB 1.769.320

TP	STOP-/PLAY-Mode	Drawer	
		opens	closes
1	0V	0V	+5V
2	0V	+5V	0V
3	0V	+10V	-10V
4	0V	+0.4V	-0.4V
5	+5V	+5V	+5V

During the opening and closing movement, direction change, and blocking of the drawer, the signal on TP5 briefly drops to zero.

TP	STOP-/PLAY-Mode	Pressing the LOAD key
6	+5V	0V (Fig. 4.4 A)
7	+5V	+3V (Fig. 4.4 B)
8	0V	+5V-pulse ca. 30ms
9	+5V	+0.7V (Fig. 4.4 C)

TP	No key pressed	Corresponding key pressed
10	0V	TTL- signal Fig. 4.4 0
11	+5V	TTL- signal Fig. 4.4 0

TP	Drawer		
	closed	half way	open
12	0V	+5V	+5V
13	0V	0V	+5V

TP	Without IR commands	With IR commands
14	+0.9V	3.8V- pulse

TP	PLAY- Mode	
15	3.8Vpp*	* = sine 4.4336MHz
16	3.5Vpp*	* = sine 6.0000MHz
17	+5V	(Drawer open = 0V)
18	+5V	(CAL. TONE 1000Hz = 0V)
19	TTL-signal	(Subcode synchronization 75Hz)
20	TTL-signal	\
21	TTL-signal	
22	TTL-signal	
23	TTL-signal	
24	TTL-signal	
24	TTL-signal	
26	TTL-signal	
27	TTL-signal	
28	TTL-signal	/

These signals are sporadic, (not periodic) and can thus not be represented. They are clock, data and enable signals.

TP	Pause from CD	No pause from CD
29	+5V	0V

TP	PLAY- Mode	Search	
30	+5V	0V*	* = for each skipped track
31	650Hz TTL	TTL-sig.	\
32	650Hz TTL	TTL-sig.	
33	650Hz TTL	TTL-sig.	
34	0V	+5V (a)	
35	+5V	0V (a)	
36	0V	+5V (a)	

Tracks that are skipped

a = intermittent



17	TTL- signal Fig. 4.5 D
18	TTL- signal Fig. 4.5 B
19	TTL- signal Fig. 4.5 A
20	TTL- signal Fig. 4.5 C
21	TTL- signal Fig. 4.6 F
22	TTL- signal Fig. 4.6 E
23	TTL- signal Fig. 4.6 G
24	TTL- signal Fig. 4.6 H
25	TTL- signal Fig. 4.7 K
26	TTL- signal Fig. 4.7 L
27	4.233MHz, sine 5Vpp
28	TTL- signal Fig. 4.7 M
29	TTL- signal Fig. 4.7 I
30	TTL- signal Fig. 4.8 O
31	TTL- signal Fig. 4.8 Q
32	TTL- signal Fig. 4.8 P
33	TTL- signal Fig. 4.8 P
34	TTL- signal Fig. 4.9 N
35	TTL- signal Fig. 4.9 R
36	TTL- signal Fig. 4.9 S
37	TTL- signal Fig. 4.9 T
38	TTL- signal Fig. 4.9 U
39	TTL- signal Fig. 4.9 V
40	-2.7V

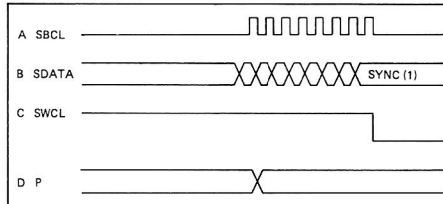

Fig. 4.5

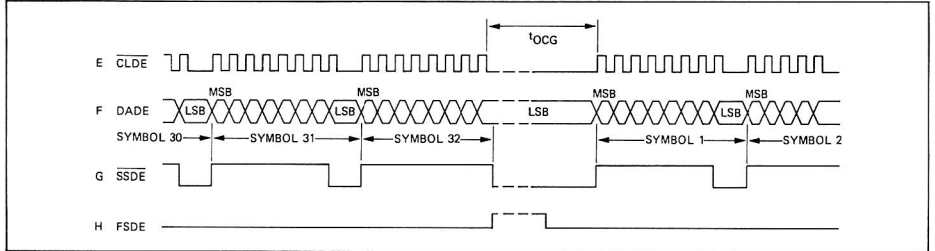

Fig. 4.6

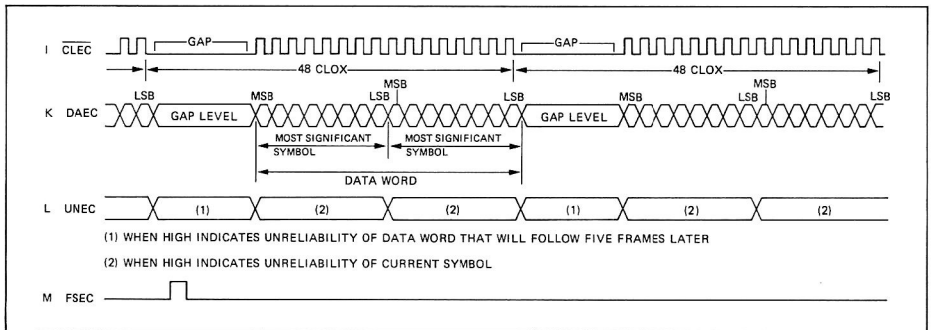

Fig. 4.7

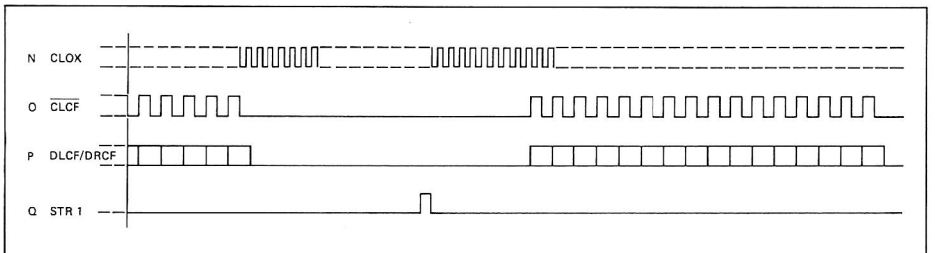

Fig. 4.8

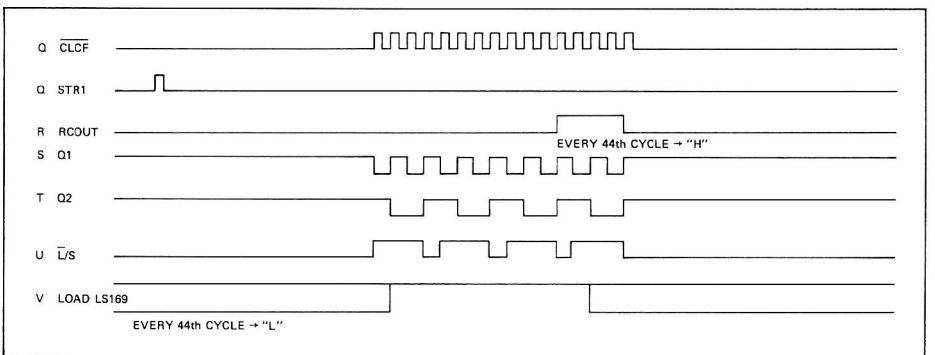

Fig. 4.9

4.1.5 Test points on DAC PCB 1.769.280

The internal calibration must be switched on for the following measurements:

TP	Measurement	
1	TTL- signal Fig. 4.10 A	
2	TTL- signal Fig. 4.10 B	
3	TTL- signal Fig. 4.10 C	
4	TTL- signal Fig. 4.10 D	
5	TTL- signal Fig. 4.10 E	
6	TTL- signal Fig. 4.10 F	
7	TTL- signal Fig. 4.10 G	
8	-5V 5%	
9	0V *	* +5V when playing a CD with preemphasis
10	-12V *	* +12V when playing a CD with preemphasis
11	sine 1kHz, 6Vpp	
12	sine 1kHz, 6Vpp	
13	sine 1kHz, 6Vpp	
14	sine 1kHz, 6Vpp	
15	sine 1kHz, 6Vpp	\
16	sine 1kHz, 14.5Vpp	Maximum level; the level of
17	sine 1kHz, 14.5Vpp	= these test points can be
18	sine 1kHz, 6Vpp	adjusted with the VOLUME
		keys.
19	+5V *	* Drawer open = 0V
20	+12V *	* Drawer open = -12V

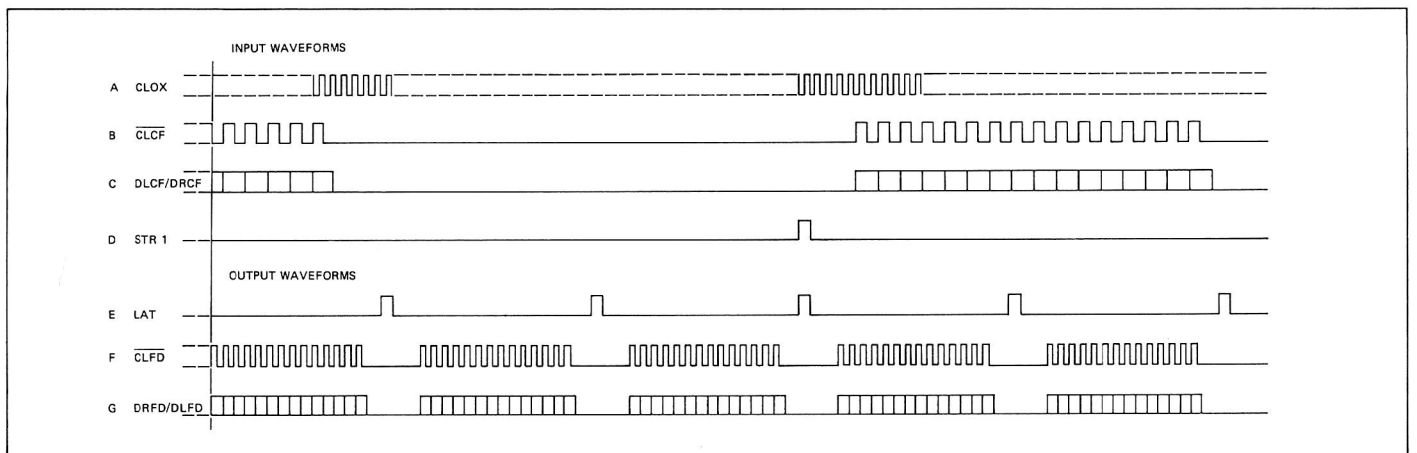

Fig. 4.10

#### 4.2 Adjustments on CD player B225

##### Note:

Cleanliness in the work area is of outmost importance and ensures that no contaminants or metal particles can enter into the CD mechanism.

If any work on printed circuit boards is necessary, it is essential to observe the ESE recommendations (refer to last page of contents).

Before putting the CD player into operation ensure that the transport screws have been unfastened.

The CD player mechanism is equipped with self-lubricating bearings which should not be lubricated.

If the drawer must be open and a disc mounted in order to perform certain measurements or adjustments, the rear light barrier must be interrupted (the detector responds as if the drawer were closed) and the compact disc must be secured with a removed adhesive magnet.

The optical system of the laser can be cleaned with an air brush.

The oscillating circuit, consisting of capacity diode DZ1 (BB 2/2) and coil L1, - to be found on DECODER PCB 1.769.300 - is automatically tuned by IC13 and DZ1. For basic alignment consult 4.2.8.

##### 4.2.1 Aids

- DC voltmeter
- Cathode ray oscilloscope
- Reference CD, frequency response, part No. 46240
- Reference CD, drop outs, part No. 46241
- Mirror CD for adjusting the optical system, part No. 46242
- Set of service PCBs and cables, part No. 46230
- ESE work location kit, part No. 46200

##### 4.2.2 Aligning the player mechanism, general

- Remove top cover.
- Connect CD player to AC supply and open the drawer by pressing the LOAD key.
- Cover rear light barrier.
- Mount reference disc 5 (part No. 46241) and secure it with a removed adhesive magnet.
- Selection 1 of the CD is to be played for all alignment work. It is, therefore, advantageous to enter the LOOP command in programming mode.

##### 4.2.3 Adjustment of laser current

- Switch CD player off, remove SERVO 2 PCB 1.769.330 and reinsert it via the service PCB (order No. 46230).
- Unfasten the left-hand tensioning spring of the housing cover by means of a screwdriver for recessed-head screws and turn to the right to prevent short circuit with the contacts of SERVO 2 PCB (see Fig. 4.12).
- Use a piece of paper to insulate the screening cover of the IR receiver on SERVO 2 PCB 1.769.330 against the adjacent PCB.
- Place the CD player on the edge of the work bench so that the drawer becomes accessible from the bottom.

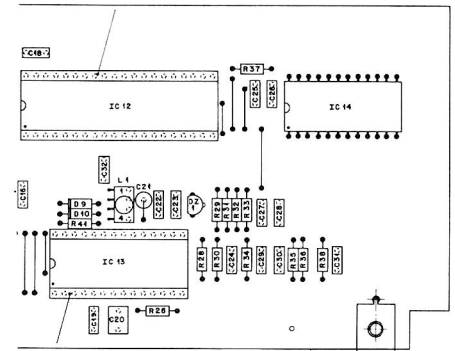

Fig. 4.11

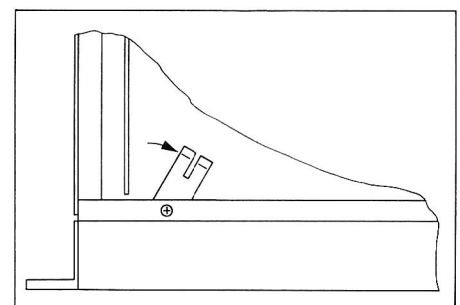

Fig. 4.12



#### 4.2.6 Checking the angle alignment

- Switch CD player off and open the drawer manually about 3/4 of the way (the two rear brass screws should be visible through the openings in the bottom panel, see Fig. 4.17).
- Unfasten the four player mechanism screws A.
- Open the drawer all the way, carefully lift the front of the player mechanism and remove the plugs of the player mechanism.
- Lift the player mechanism out of the drawer and remove the top plastic cover (unfasten two cross-recessed screws).
- Place the mirror on the laser lens and the glass CD on the player mechanism (both in set No. 46242).
- Position the player mechanism below a straight light source (e.g. fluorescent lamp).
- Put the laser pickup arm into the center position and turn the player mechanism in such a way that the arm is parallel to the light source (see Fig. 4.18).
- When viewing the two light source reflections in the glass CD and in the mirror on the pickup (as illustrated in Fig. 4.18), the lateral offset should not exceed 2.5 mm.
- Set up the player mechanism in such a way that the light source forms a 90 degree angle to the pickup arm (see Fig. 4.19).
- The distance between the two reflections should again not exceed 2.5 mm.

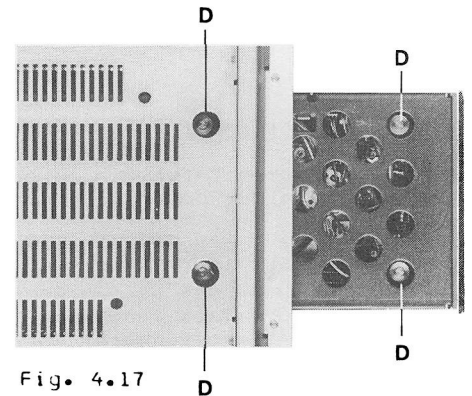

Fig. 4.17

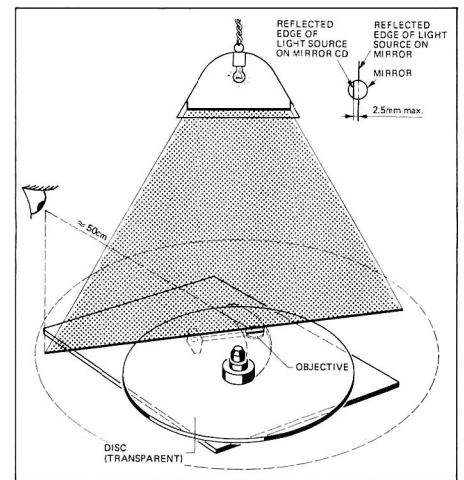

Fig. 4.18

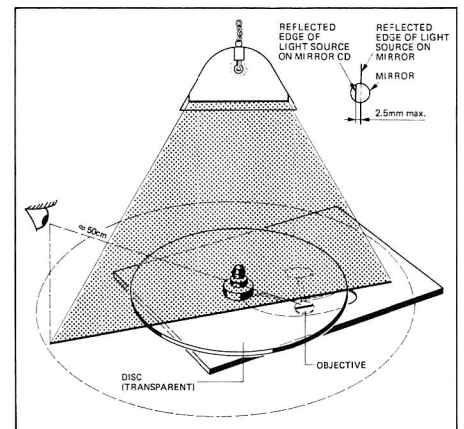

Fig. 4.19



The angle alignment must be corrected if the deviation is too large:

- Loosen screws [A] with Torx key No. 8 until the support plate [B] can be shifted.
- The support plate can now be shifted according to Fig. 4.20. Retighten the screws [A] when the position is correct.
- The angle alignment must be rechecked after these adjustments.
- Remount the top plastic cover and reinstall player mechanism. Check the DC component of the focus signal according to 4.2.7.

#### 4.2.7 Adjusting the DC component of the focus signal

- Connect DC voltmeter to R1 (SERVO 1 PCB 1.769.315).

The following adjustment is only necessary if the DC deviation exceeds  $\pm 140$  mV. Replace the motor if alignment is not possible.

- Adjust the axial set screw of the disc motor in such a way that  $0 \text{ V} \pm 50 \text{ mV}$  is measured.
- If the motor is replaced, perform the adjustments according to 4.2.6 and 4.2.7.

#### 4.2.8 Adjusting coil L1

The following adjustment is required if a newly inserted CD does not always start correctly.

- Switch CD player off, remove DECODER PCB 1.769.300 and reconnect it via the service PCB (order No. 46230).
- Connect digital voltmeter to pin 18 of IC13.
- Adjust in PLAY mode to a voltage of 4.75 VDC by turning the tuning core of L1.
- Reinsert DECODER PCB 1.769.300.

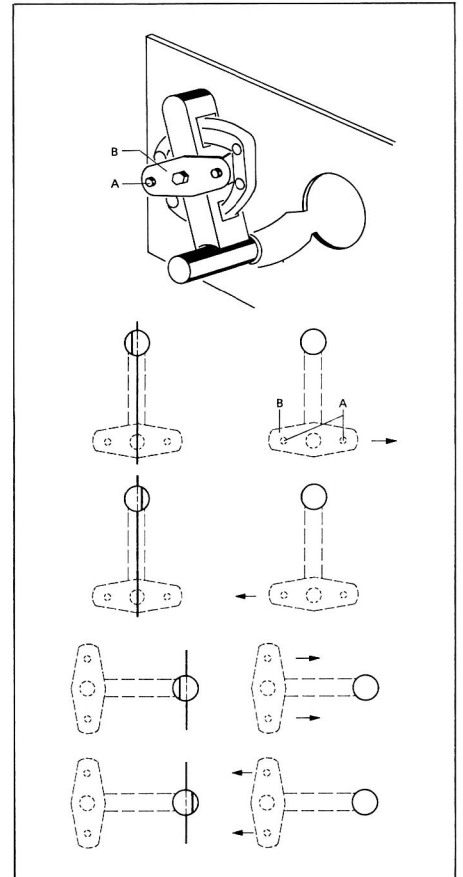

Fig. 4.20

### 4.3 Measuring the audio data

#### 4.3.1 Aids

- Reference CD, part No. 46240
- Automatic distortion meter (e.g. Tektronix AA 501; the RESPONSE button must be in the RMS position for all measurements)
- Measuring filter (for distortion measurement)
- Frequency counter
- Oscilloscope

#### 4.3.2 Harmonic distortion

- Measuring arrangement according to Fig. 4.21.
- Adjust for maximum level with VOLUME + key
- Mount reference disc (part No. 46240). Play track 4 for measuring the left-hand channel and track 8 for measuring the right-hand channel.
- The harmonic distortion should be less than 0.006%.

#### 4.3.3 Output level

- Press CAL TONE button and adjust for maximum level with VOLUME + key.
- The level of the FIXED and VARIABLE outputs should be 2 V RMS  $\pm 10\%$ . The balance between channels should be better than 0.2 dB.

#### 4.3.4 Frequency response

- Adjust for maximum level with VOLUME + key.
- The calibration tone (1 kHz) serves as the 0 dB reference.
- Play tracks 4 and 8 (CD part No. 46240) and measure the outputs FIXED and VARIABLE. The frequency response should be within  $+0$  to  $-0.6$  dB.



Fig. 4.21

#### 4.3.5 Cross talk

- Adjust for maximum level with VOLUME + key.
- Reference = CAL TONE 1000 Hz)
- Measure both outputs across a 30 kHz low-pass:  
Play track 8 for measuring cross talk R -> L  
Play track 4 for measuring cross talk L -> R
- The cross talk attenuation should be at least 90 dB.

#### 4.3.6 Signal-to-noise ratio, linear

- Maximum volume, reference = CAL TONE 1000 Hz.
- Play track 18 and measure the outputs FIXED and VARIABLE via a 30 kHz low-pass.
- The measured value should be higher than 96 dB.

#### 4.3.7 Signal-to-noise ratio, weighted

- Maximum volume, reference = CAL TONE 1000 Hz.
- Play track 18 and measure the outputs FIXED and VARIABLE via an A filter.
- The measured value should be higher than 100 dB.

#### 4.3.8 Phase linearity

- Connect oscilloscope to one of the outputs.
- Play track 20 and visually assess the square-wave signals at 100 Hz, 400 Hz, 1002 Hz, and 5512 Hz. The curve should be shaped symmetrically (see Fig. 4.22).

#### 4.4 Listening test with reference CD (part No. 46241)

The reference CD simulates the following errors for checking the error correction system:

- Information gaps with a length of 400 to 900  $\mu\text{m}$  (tracks 5 through 9)
- Black dots from 300 to 800 micrometers (tracks 11 through track 17)
- Simulated fingerprint (tracks 18 and 19)

The simulated defects should not cause any drop-outs (reproduction gaps). If drop-outs become audible, this can for example be caused by the following errors:

- IC13 (SAA 7010, demodulator), clock regeneration with PLL defect.
- HFL an DO detector defective.

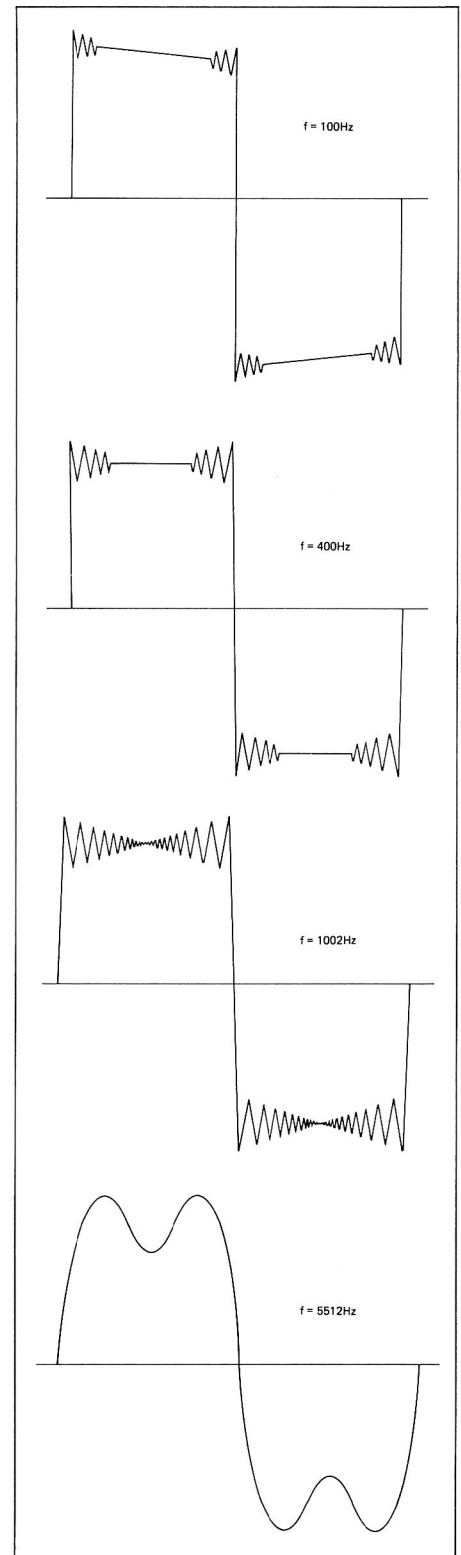
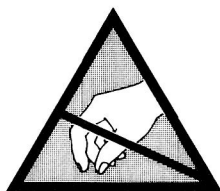

Fig. 4.22

## CONTENTS

DESCRIPTION	SCHEMATIC NO.	SECTION/PAGE
BLOCK DIAGRAM B225		5/2
KEYBOARD RIGHT	1.769.200-00	5/3
KEYBOARD LEFT	1.769.210-00	5/3
INTERCONNECTION PCB	1.769.230-00	5/5
MAINS TRANSFORMER UNIT	1.769.260-00	5/6
SERVO 1 PCB	▲ 1.769.310-00/315-00	5/7
SERVO 2 PCB	▲ 1.769.330-00	5/11
MICROPROCESSOR PCB	▲ 1.769.320-00	5/13
LCD PCB	▲ 1.769.250-00	5/15
CONNECTION PCB	1.769.390-00/-81	5/17
CONNECTION PCB	1.769.395-00	5/19
CD-DRIVE MECHANISM	▲ 1.769.110-00	5/21
CD-DRIVE MECHANISM	▲ 1.769.112-00	5/22
INTERCONNECTION PCB RIGHT	1.769.220-00	5/23
DECODER PCB	▲ 1.769.300-00	5/25
DAC PCB	▲ 1.769.280-00	5/27



ALL PCBs MARKED WITH THIS SIGN ▲  
CONTAIN COMPONENTS SENSITIVE TO  
STATIC CHARGES.  
PLEASE, REFER TO PREFACE BEFORE  
YOU REMOVE THESE BOARDS.

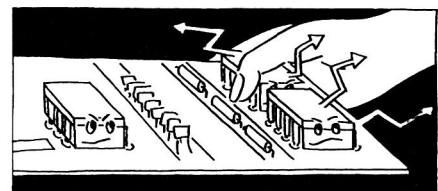

BLOCK DIAGRAM B225

14.10.83 DSe STUDER BLOCK DIAGRAM

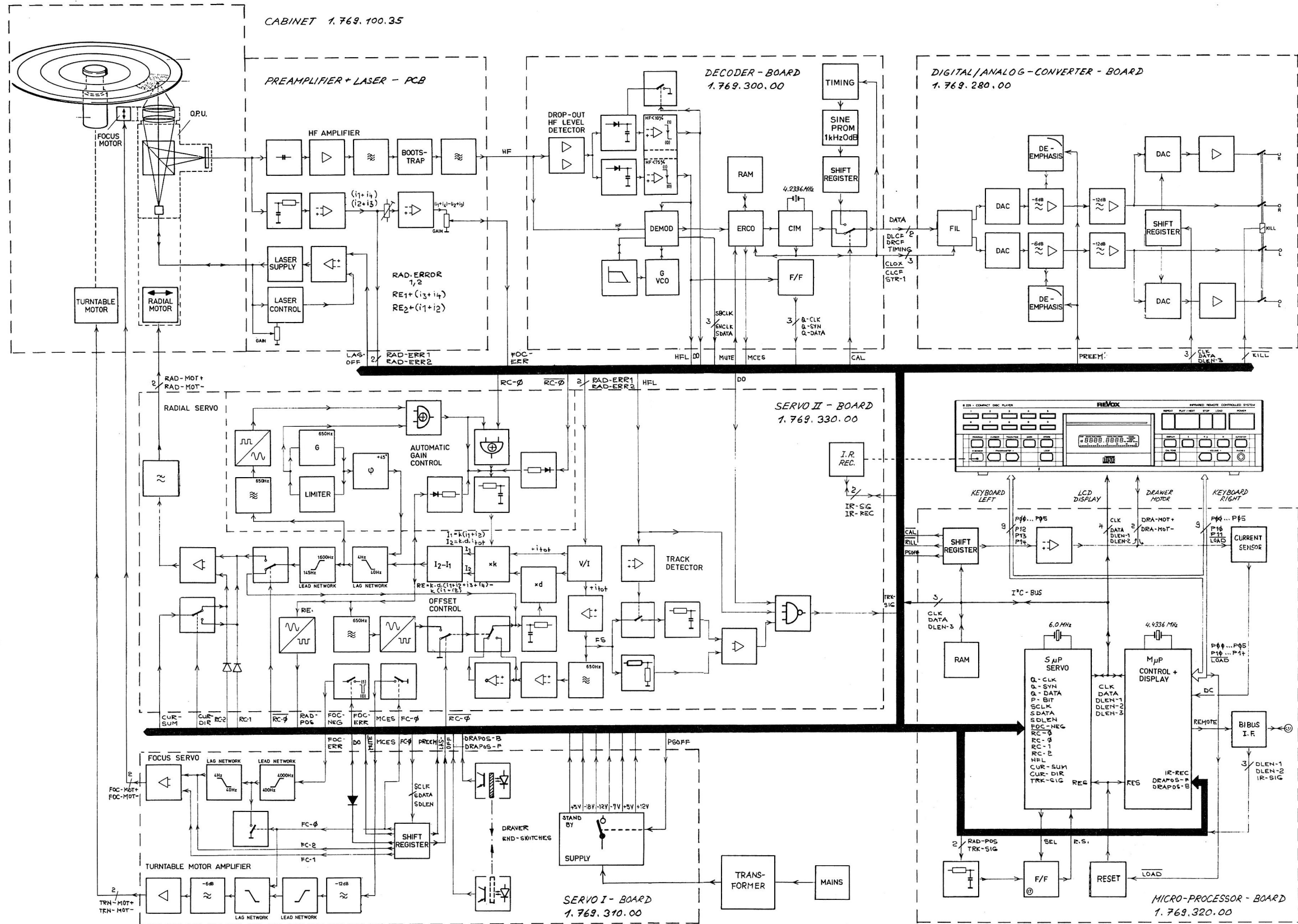

14.10.83 DSe STUDER BLOCK DIAGRAM

KEYBOARD RIGHT 1.769.200-00  
 KEYBOARD LEFT 1.769.210-00

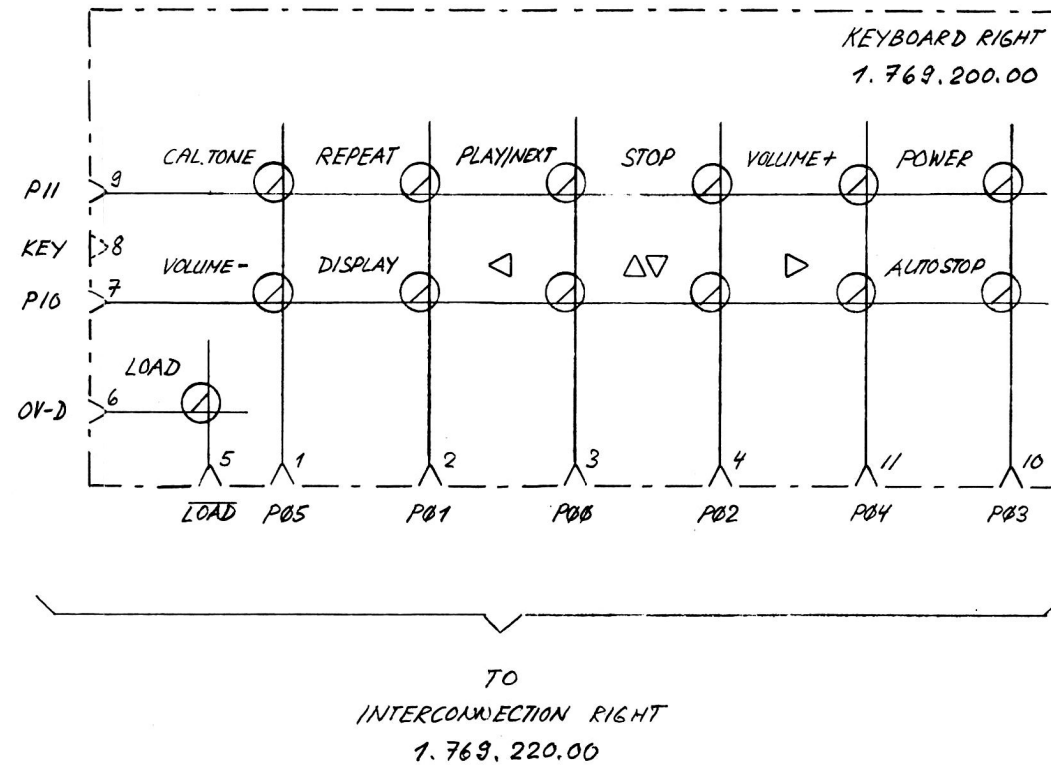
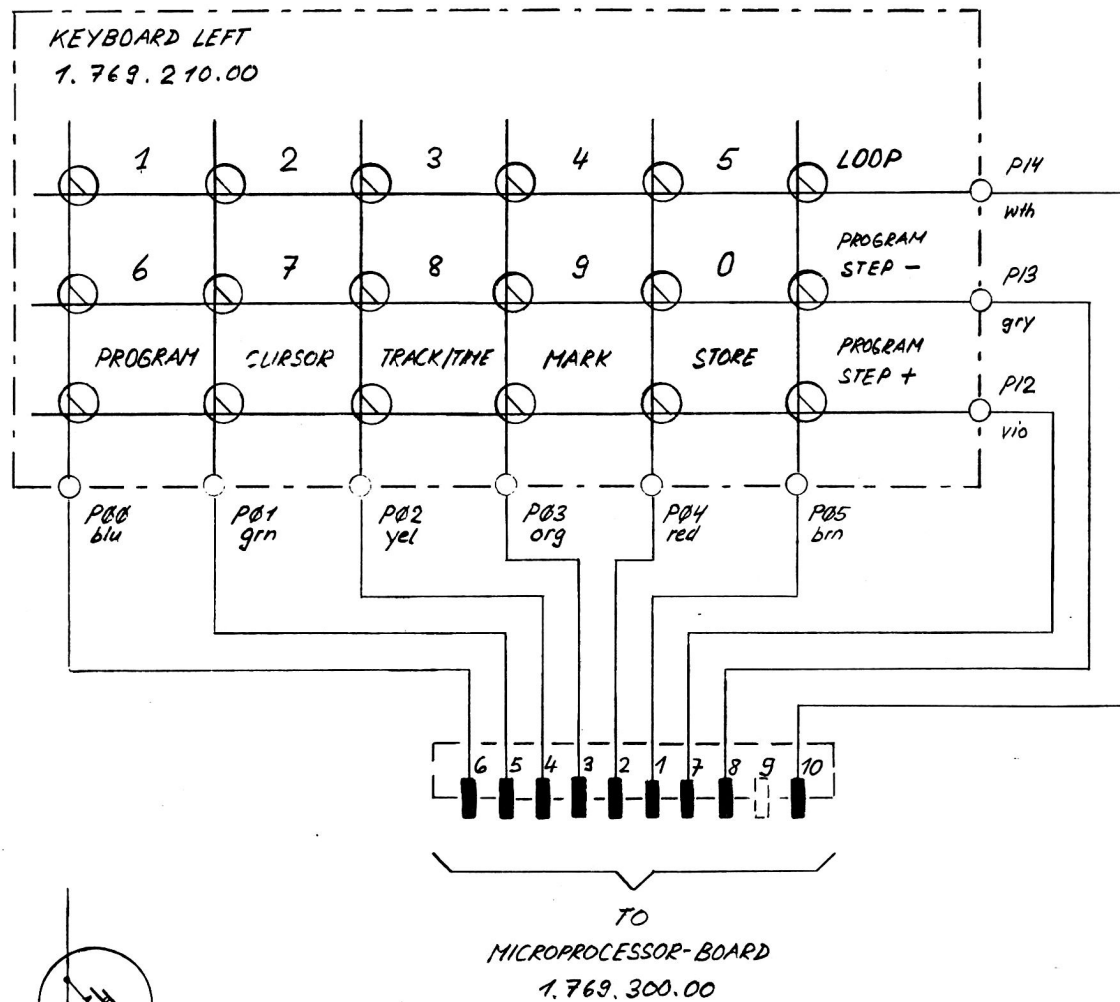
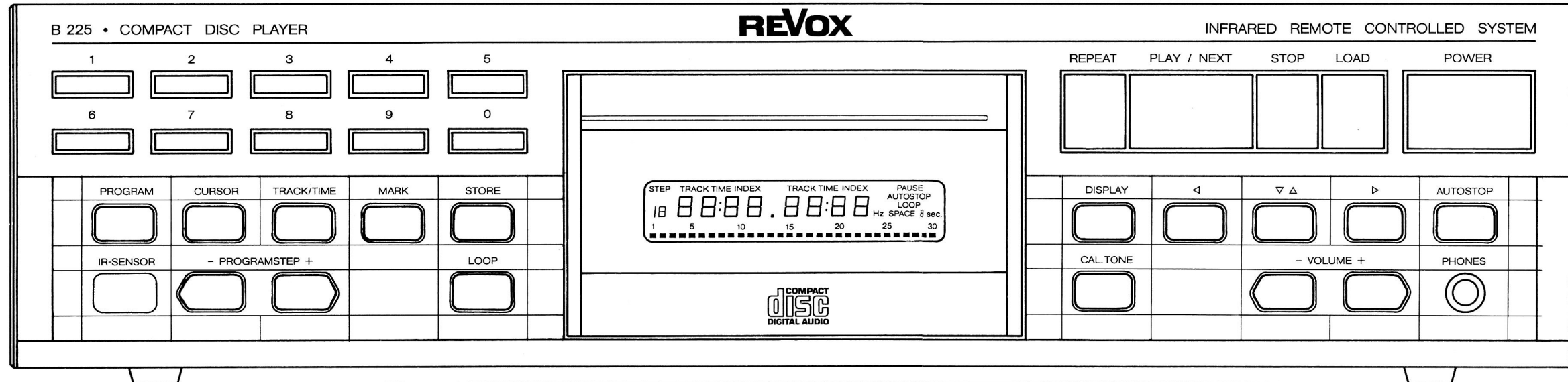

KEYBOARD RIGHT 1.769.200-00  
 KEYBOARD LEFT 1.769.210-00

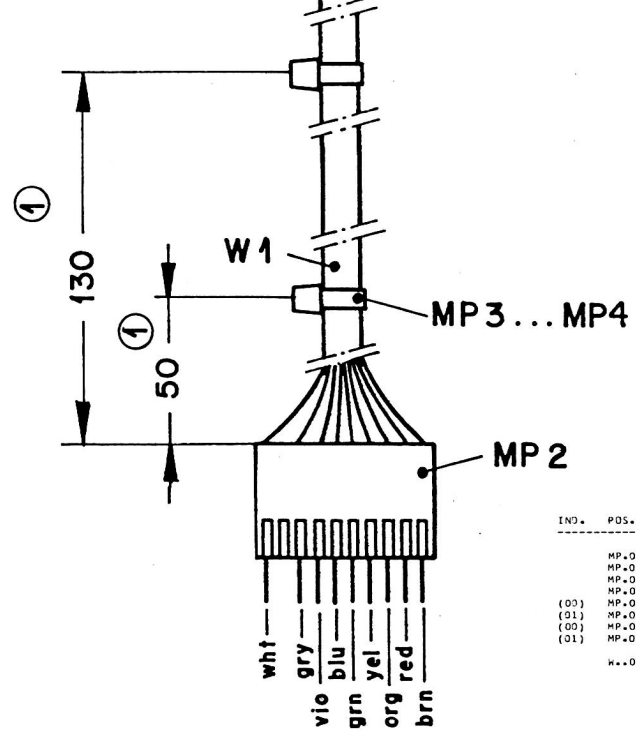
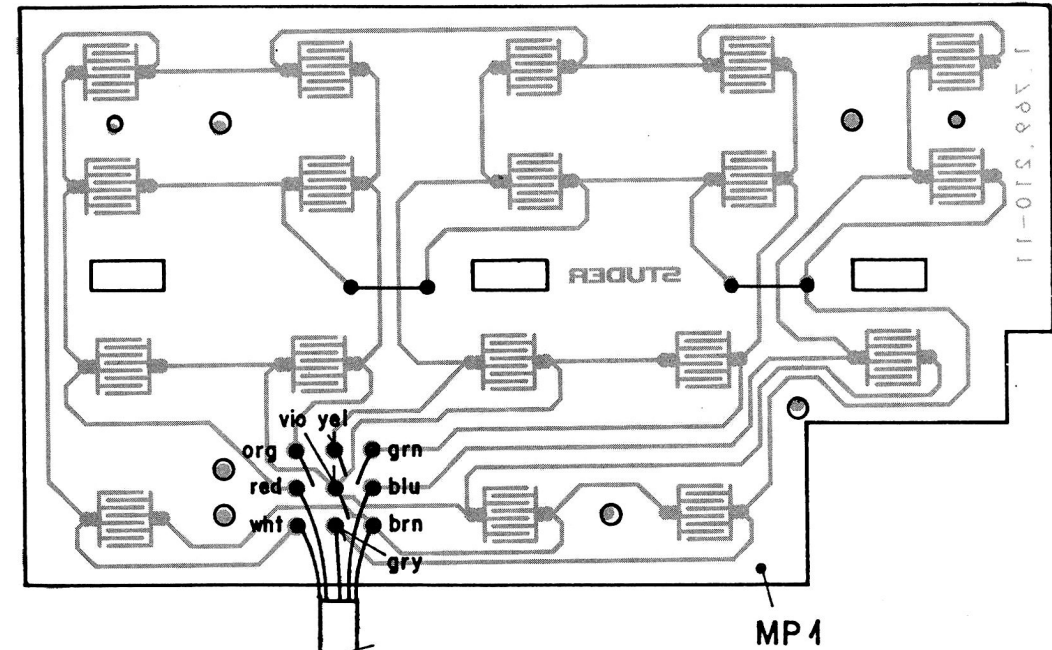
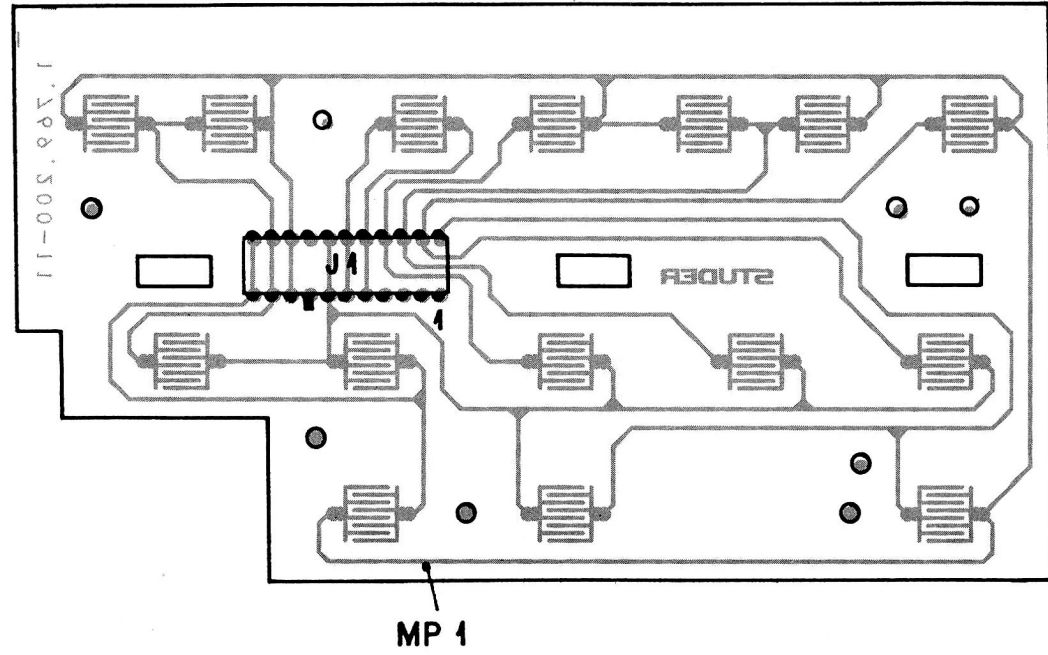

IND.	POS.ND.	PART NO.	VALUE	SPECIFICATIONS / EQUIVALENT	MANUF.
		MP.0001	1.769.200.11	KEYBOARD-PCB RIGHT	St
		J..0001	54.01.0308	11 POLE CIS SOCKET STRIP	

IND.	POS.ND.	PART NO.	VALUE	SPECIFICATIONS / EQUIVALENT	MANUF.
		MP.0001	1.769.210.11	KEYBOARD-PCB LEFT	St
		MP.0002	34.01.0256	10 POLE CIS PIN CASE	
		MP.0003	35.03.0109	TY-RAP	
		MP.0004	35.03.0109	TY-RAP	
(00)		MP.0005	35.03.0109	TY-RAP	
(01)		MP.0005		not used	
(00)		MP.0006	35.03.0109	TY-RAP	
(01)		MP.0006		not used	
		W..0001	1.769.210.93	WIRING-LIST KEYBOARD LEFT	St

MANUFACTURER: St=Studer  
 ORIG 83/10/13  
 S T U D E R 83/10/13 DR KEYBOARD RIGHT 1.769.200.00 PAGE 1

(01) 10.01.84 modification after 0-serie  
 MANUFACTURER: St=Studer  
 ORIG 83/10/13 (01) 84/01/10  
 S T U D E R 84/01/10 DR KEYBOARD LEFT 1.769.210.00 PAGE 1



INTERCONNECTION PCB LEFT 1.769.230-00

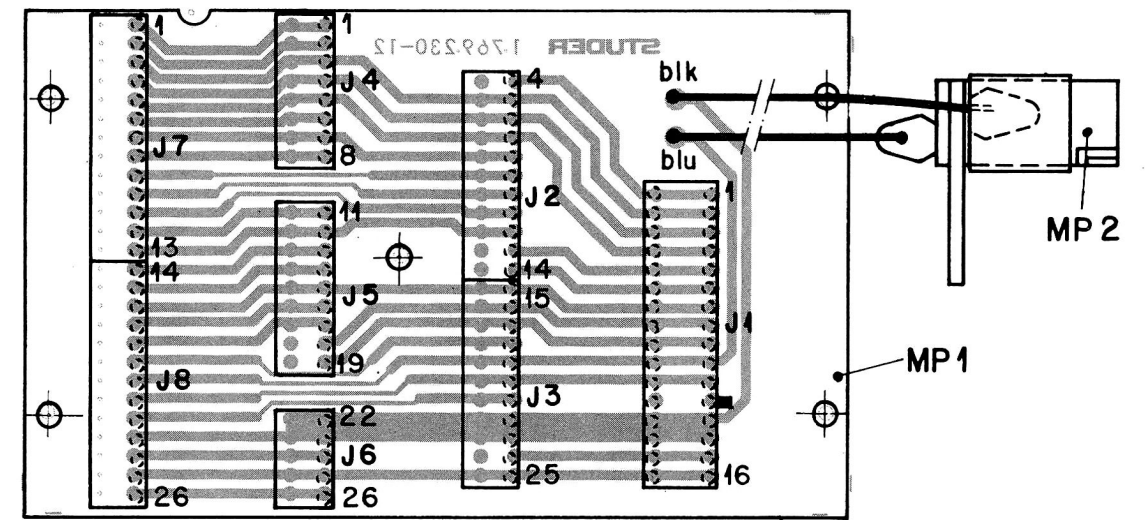
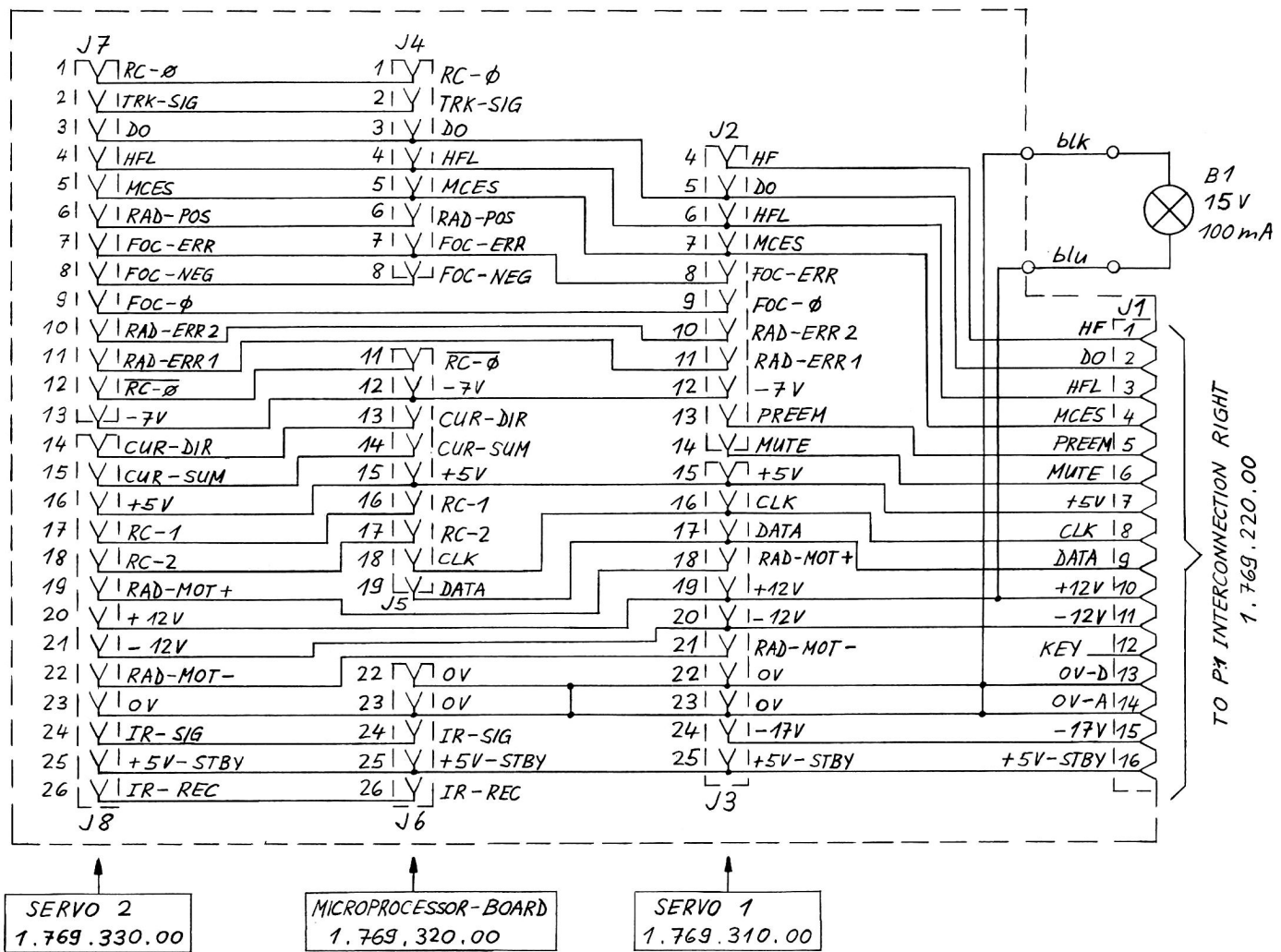

IND.	POS. NO.	PART NO.	VALUE	SPECIFICATIONS / EQUIVALENT	MANUF.
	J..0001	54.01.0311	16 POLE	CIS SOCKET STRIP	
	J..0002	54.01.0240	11 POLE	CIS SOCKET STRIP	
	J..0003	54.01.0240	11 POLE	CIS SOCKET STRIP	
	J..0004	54.01.0262	8 POLE	CIS SOCKET STRIP	
	J..0005	54.01.0235	9 POLE	CIS SOCKET STRIP	
	J..0006	54.01.0246	5 POLE	CIS SOCKET STRIP	
	J..0007	54.01.0299	13 POLE	CIS SOCKET STRIP	
	J..0008	54.01.0299	13 POLE	CIS SOCKET STRIP	
(00)	MP..0001	1.769.230.11		INTERCONNECTION-PCB LEFT	St
(01)	MP..0001	1.769.230.12		INTERCONNECTION-PCB LEFT	St
(02)	MP..0002	53.04.0121		LAMP-CONNECTOR	
	W..0001	1.769.230.93		WIRING-LIST INTERCONNECTION LEFT	St
(03)	W..0002	1.010.132.65		SHRINKING-TUBE	St

28.10.83 GP	10.1.84 GP	B 225 COMPACT-DISC-PLAYER	
STUDER	INTERCONNECTION LEFT	SC 1.769.230.00	PAGE 1 OF 1

(01) 10.01.84 modification after 0-serie  
 (02) 17.02.84  
 (03) 17.04.85  
 MANUFACTURER: St-Studer  
 ORIG 85/10/13 (01) 84/01/10 (02) 84/02/17 (03) 85/04/17  
 S T U D E R (03) 85/04/17 DR INTERCONNECTION LEFT 1.769.230.00 PAGE 1

MAINS TRANSFORMER UNIT 1.769.260-00

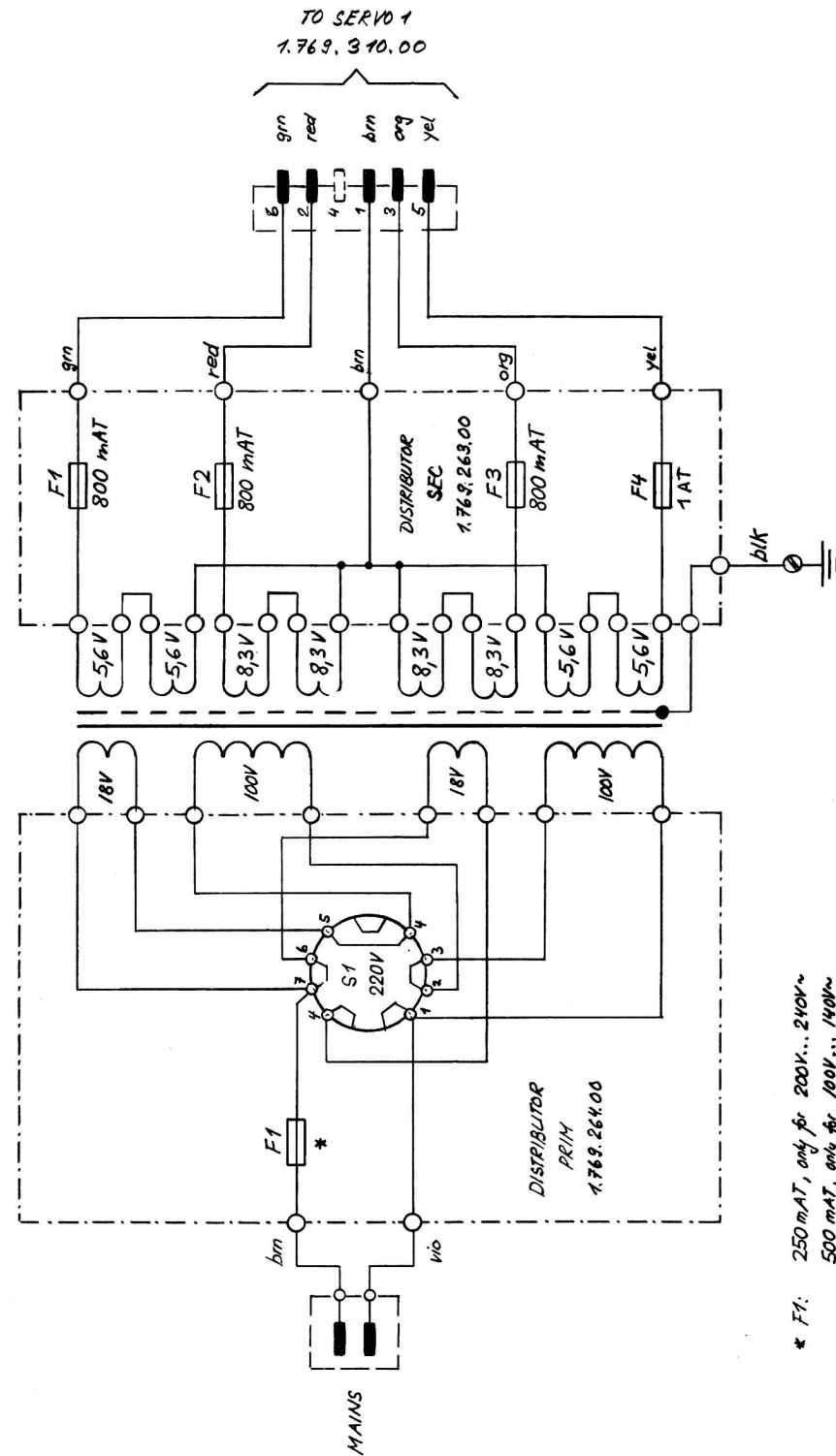

\* F1: 250 mA T, only for 200V...240V  
500 mA T, only for 100V...140V  
all fuses are slow blow

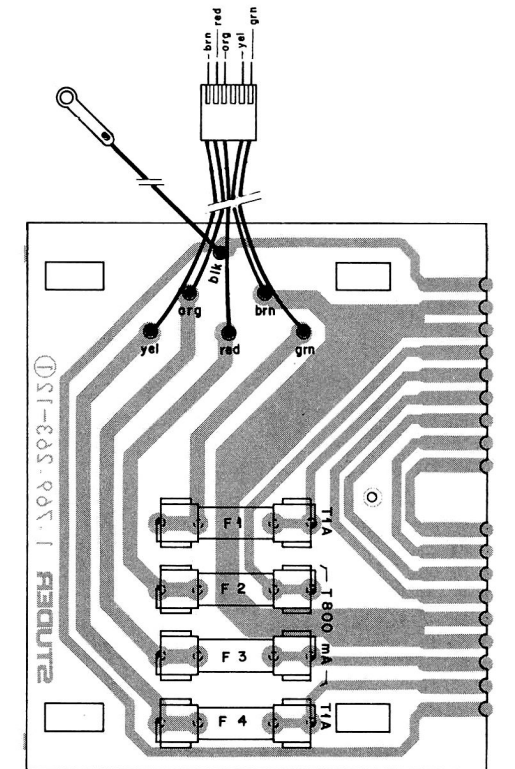
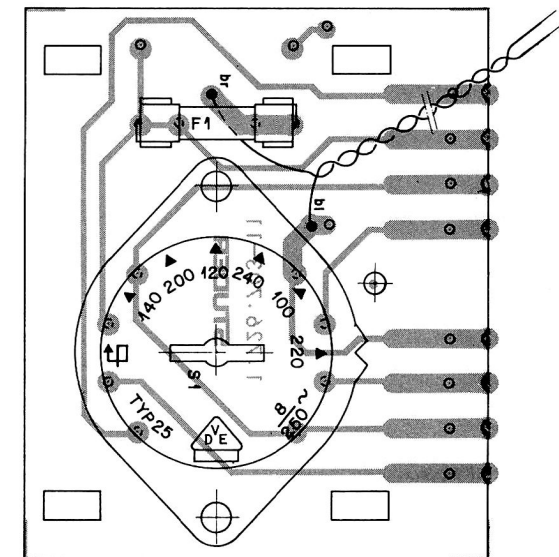
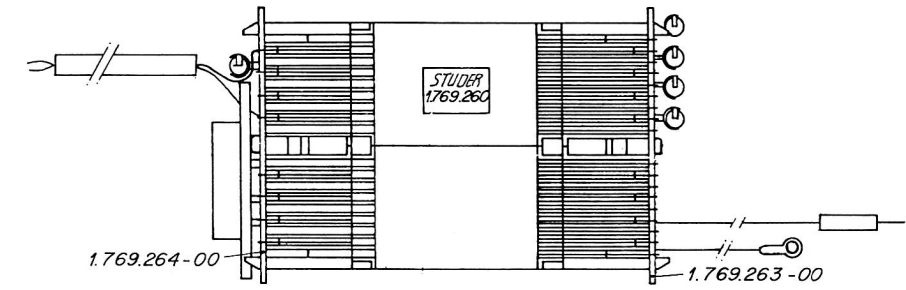

IND.	POS.NO.	PART NO.	VALUE	SPECIFICATIONS / EQUIVALENT	MANUF.
(00)	F.....1	51.01.0109		FUSE: T 160mA 5 20 : SEE NOTE	
(01)	F.....1	51.01.0111		FUSE: T 250mA 5 20 : SEE NOTE	
MP.....1		1.726.703.11		DISTRIBUTOR-PCB PRIM	St
MP.....3		53.03.0142		FUSE-CLIP	
MP.....4		53.03.0142		FUSE-CLIP	
S.....1		53.03.0131		VOLTAGE SELECTOR 100...240 VAC	
W.....1		1.769.264.93		WIRING-LIST DISTRIBUTOR PRIM	St

IND.	POS.NO.	PART NO.	VALUE	SPECIFICATIONS / EQUIVALENT	MANUF.
(00)	F.....1	51.01.0115		T 630MA 5 20	
(01)	F.....1	51.01.0116		T 800MA 5 20	
(02)	F.....1	51.01.0117		T 1 A 5 20	
(00)	F.....2	51.01.0115		T 630MA 5 20	
(01)	F.....2	51.01.0116		T 800MA 5 20	
(00)	F.....3	51.01.0115		T 630MA 5 20	
(01)	F.....3	51.01.0116		T 800MA 5 20	
(00)	F.....4	51.01.0115		T 630MA 5 20	
(01)	F.....4	51.01.0116		T 800MA 5 20	
(02)	F.....4	51.01.0117		T 1 A 5 20	
(00)	MP.....1	1.769.263.11		DISTRIBUTOR-PCB SEC	St
(01)	MP.....1	1.769.263.12		DISTRIBUTOR-PCB SEC	St
MP.....2		53.03.0142		FUSE-CLIP	
MP.....3		53.03.0142		FUSE-CLIP	
MP.....4		53.03.0142		FUSE-CLIP	
MP.....5		53.03.0142		FUSE-CLIP	
MP.....6		53.03.0142		FUSE-CLIP	
MP.....7		53.03.0142		FUSE-CLIP	
MP.....8		53.03.0142		FUSE-CLIP	
MP.....9		53.03.0142		FUSE-CLIP	
W.....1		1.769.263.93		WIRING-LIST DISTRIBUTOR SEC	St

03/10/83 DE	21.2.84 GP	B225 COMPACT DISC PLAYER		
STUDER	MAINS-TRANSFORMER	SC	1.769.260.00	PAGE 1 OF 1

(01) 10-01-84 modification after 0-series  
 F1: PART NO. 51.01.0111 250mA T 5920 \*only for 200...240V  
 F1: PART NO. 51.01.0114 500mA T 5920 \*only for 100...140V  
 ORIG 83/10/04 (01) 84/01/10  
 S T U D E R 84/01/10 DR DISTRIBUTOR PRIM 1.769.264.00 PAGE 1

(01) 10-01-84 modification after 0-series  
 (02) 07-09-84  
 MANUFACTURER: St=Studer  
 ORIG 83/10/04 (01) 84/01/10 (02) 84/09/07  
 S T U D E R (02) 84/09/07 DR DISTRIBUTOR SEC 1.769.263.00 PAGE 1



SERVO 1 PCB 1.769.310-00/315-00 "ESE"

27.10.83 GP ③ 6.6.84 DR B 225 COMPACT-DISC-PLAYER  
 STUDER SERVO 1 PCB "ESE" SC 1.769.310.00 PAGE 1 OF 2

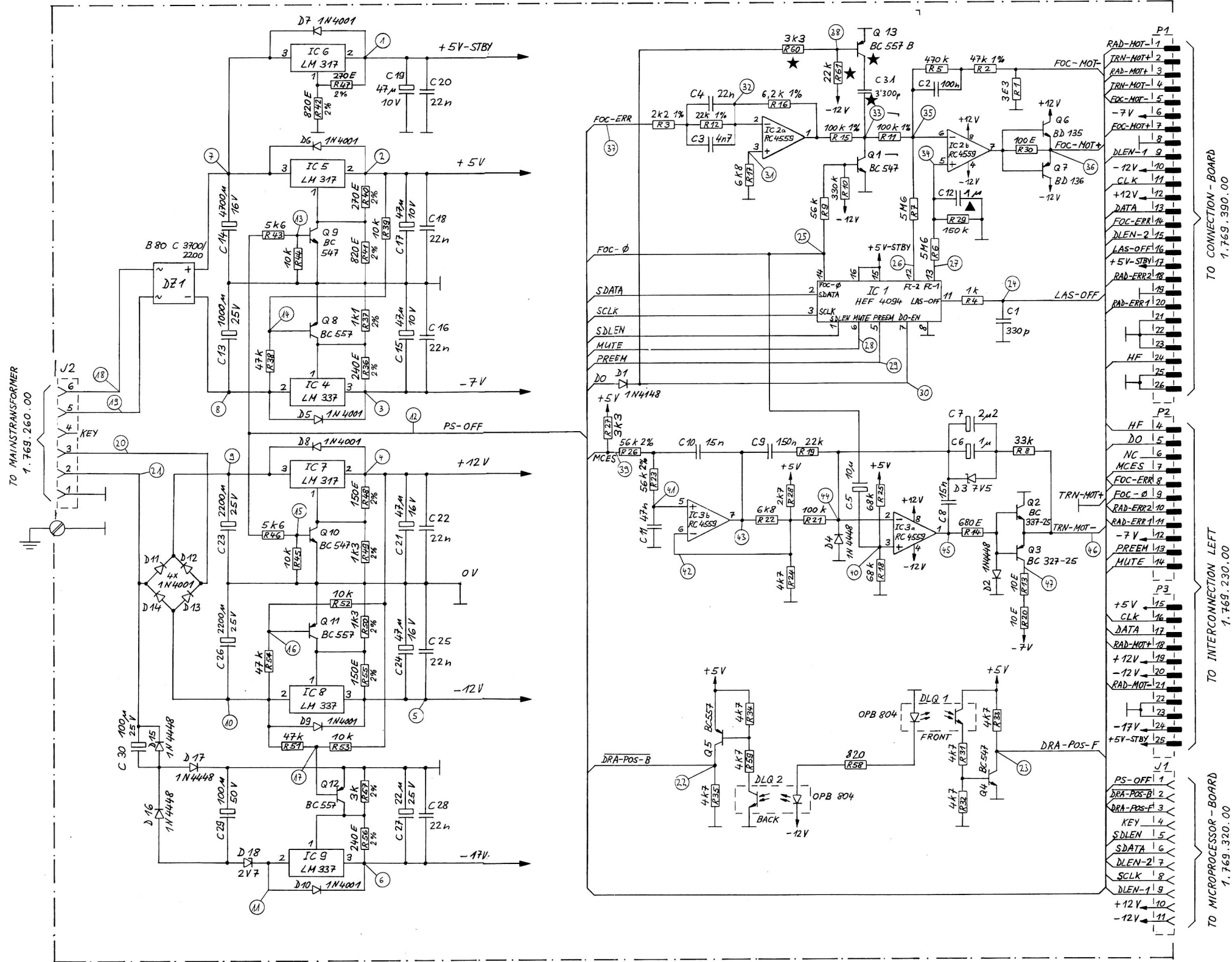

★ NOT USED FOR 1.769.315  
 ▲ HAS BEEN MODIFIED

27.10.83 GP ③ 6.6.84 DR B 225 COMPACT-DISC-PLAYER  
 STUDER SERVO 1 PCB "ESE" SC 1.769.310.00 PAGE 2 OF 2

TO MAINSTRANSFORMER 1.769.260.00  
 TO CONNECTION-BOARD 1.769.390.00  
 TO INTERCONNECTION LEFT 1.769.230.00  
 TO MICROPROCESSOR-BOARD 1.769.320.00

SERVO 1 PCB 1.769.310-00 "ESE"

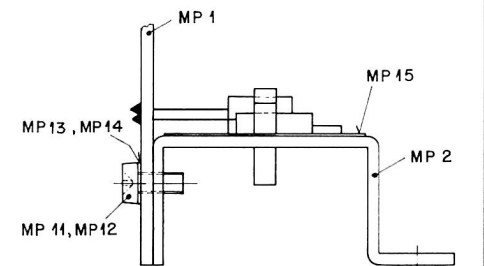
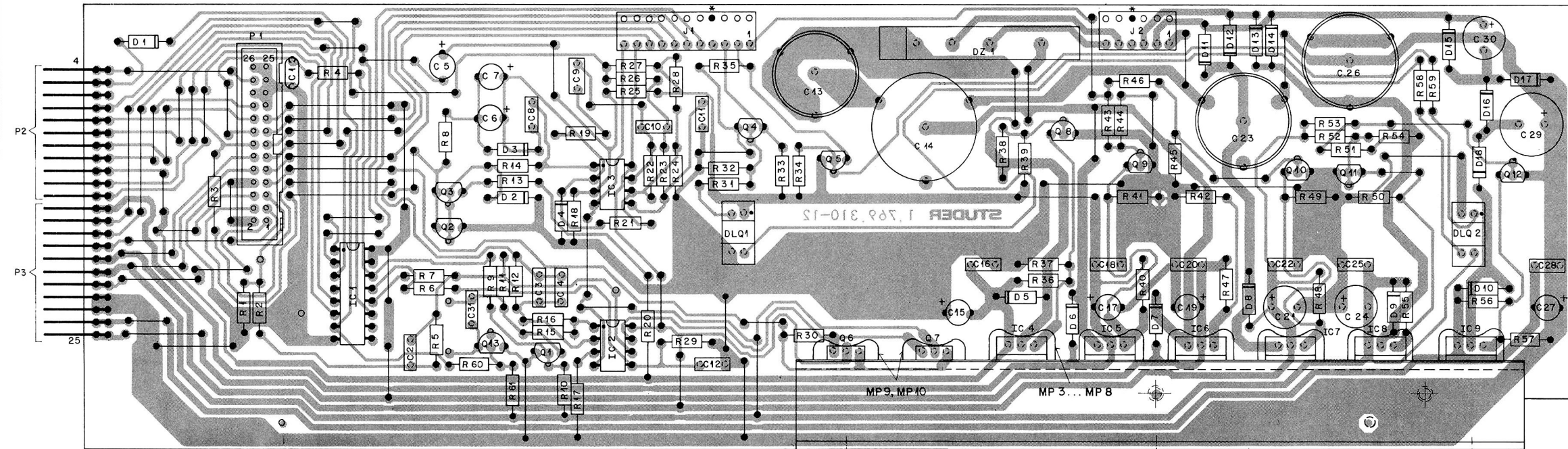

IND.	POS.-NO.	PART NO.	VALUE	SPECIFICATIONS / EQUIVALENT	MANUF.
		C.....1	59-34-4331	330 p	cer
		C.....2	59-06-0104	100 n	cer
		C.....3	59-06-0472	4.7 n	cer
		C.....4	59-06-0223	22 n	cer
		C.....5	59-22-4100	10 u	16V, el
		C.....6	59-22-8109	1 u	16V, el
		C.....7	59-22-8229	2.2 u	16V, el
		C.....8	59-06-0153	15 n	cer
		C.....9	59-06-0154	150 n	cer
		C.....10	59-06-0153	15 n	cer
		C.....11	59-06-0473	47 n	cer
		C.....12	59-06-0126	100 n	cer
(00)		C.....12	59-06-0126	100 n	cer
(01)		C.....13	59-22-4222	2200 u	16V, el
		C.....13	59-22-5102	1000 u	25V, el
		C.....14	59-22-4472	4700 u	10V, el
		C.....15	59-22-3470	47 u	10V, el
		C.....16	59-06-0223	22 n	cer
		C.....17	59-22-3470	47 u	10V, el
		C.....18	59-06-0223	22 n	cer
		C.....19	59-22-3470	47 u	10V, el
		C.....20	59-06-0223	22 n	cer
		C.....21	59-22-4470	47 u	10V, el
		C.....22	59-06-0223	22 n	cer
		C.....23	59-22-5222	2200 u	25V, el
		C.....24	59-22-4470	47 u	10V, el
		C.....25	59-06-0223	22 n	cer
		C.....26	59-22-5222	2200 u	25V, el
		C.....27	59-22-5220	22 u	25V, el
		C.....28	59-06-0223	22 n	cer
		C.....29	59-22-8101	100 u	50V, el
		C.....30	59-22-5101	100 u	25V, el
(01)		C.....31	59-06-0332	3.3 n	cer
		D.....1	50-04-0125	1N 4448	SI general purpose
		D.....2	50-04-0125	1N 4448	SI general purpose
		U.....3	50-04-1103	7.5 V	zener, .4W

S T U D E R (04) 84/09/26 DR SERVO 1 1.769-310.00 PAGE 1

IND.	POS.-NO.	PART NO.	VALUE	SPECIFICATIONS / EQUIVALENT	MANUF.
		D.....4	50-04-0125	1N 4448	SI general purpose
		D.....5	50-04-0122	1N 4001	50V, 1A
		D.....6	50-04-0122	1N 4001	50V, 1A
		D.....7	50-04-0122	1N 4001	50V, 1A
		D.....8	50-04-0122	1N 4001	50V, 1A
		D.....9	50-04-0122	1N 4001	50V, 1A
		D.....10	50-04-0122	1N 4001	50V, 1A
		D.....11	50-04-0122	1N 4001	50V, 1A
		D.....12	50-04-0122	1N 4001	50V, 1A
		D.....13	50-04-0122	1N 4001	50V, 1A
		D.....14	50-04-0122	1N 4001	50V, 1A
		D.....15	50-04-0125	1N 4448	SI general purpose
		D.....16	50-04-0125	1N 4448	SI general purpose
		D.....17	50-04-0125	1N 4448	SI general purpose
(01)		D.....18	50-04-1106	2.7 V	zener, .4W
		DLQ.....1	50-04-2128	OPB 804	OPTO-COUPLER
		DLQ.....2	50-04-2128	OPB 804	OPTO-COUPLER
		DZ.....1	70-01-0235	B 80 C 3700/2200	RECTIFIER
		IC.....1	50-07-0018	HEF 4094	CMOS SHIFT-REGISTER
		IC.....2	50-09-0107	RC 4559	DUAL OP-AMP
		IC.....3	50-09-0107	RC 4559	DUAL OP-AMP
		IC.....4	50-10-0105	LM 337	NEG. VOLTAGE-REGULATOR
		IC.....5	50-10-0104	LM 317	POS. VOLTAGE-REGULATOR
		IC.....6	50-10-0104	LM 317	POS. VOLTAGE-REGULATOR
		IC.....7	50-10-0104	LM 317	POS. VOLTAGE-REGULATOR
		IC.....8	50-10-0105	LM 337	NEG. VOLTAGE-REGULATOR
		IC.....9	50-10-0105	LM 337	NEG. VOLTAGE-REGULATOR
		J.....1	54-01-0291	11 PDL	CIS SOCKET STRIP
		J.....2	54-01-0216	6 PDL	CIS SOCKET STRIP
(00)		MP.....1	1.769-310-11		SERVO 1-PCB
(01)		MP.....1	1.769-310-12		SERVO 1-PCB
		MP.....2	1.769-310-01		HEAT-SINK

S T U D E R (04) 84/09/26 DR SERVO 1 1.769-310.00 PAGE 2

IND.	POS.-NO.	PART NO.	VALUE	SPECIFICATIONS / EQUIVALENT	MANUF.
		MP.....3	50-20-2033		CLIP TO 220
		MP.....4	50-20-2033		CLIP TO 220
		MP.....5	50-20-2033		CLIP TO 220
		MP.....6	50-20-2033		CLIP TO 220
		MP.....7	50-20-2033		CLIP TO 220
		MP.....8	50-20-2033		CLIP TO 220
		MP.....9	50-20-2032		CLIP TO 126
		MP.....10	50-20-2032		CLIP TO 126
		MP.....11	21-26-0354		SCREW, CYLIN.-HEAD, M3-0.6
		MP.....12	21-26-0354		SCREW, CYLIN.-HEAD, M3-0.6
		MP.....13	24-16-1030		WASHER, D 5.5/3.2
		MP.....14	24-16-1030		WASHER, D 5.5/3.2
		MP.....15	1.769-310-03		THERMOPLASTIC
		P.....1	54-01-2033	26 PIN	FLAT-CABLE PCB-CONNECTOR
		P.....2	54-01-0431	11 PIN	CIS STRIP
		P.....3	54-01-0431	11 PIN	CIS STRIP
		U.....1	50-03-0436	BC 947B	BC 237B, BC 550B
(00)		Q.....2	50-03-0495	BD 135	NPN, 45V, 1.5A
(01)		Q.....2	50-03-0340	BC 337-2	5
(01)		Q.....3	50-03-0510	BD 136	PNP, 45V, 1.5A
(01)		Q.....3	50-03-0351	BC 327-2	5
		U.....4	50-03-0436	BC 947B	BC 237B, BC 550B
		U.....5	50-03-0515	BC 307B	BC 560B
		U.....6	50-03-0495	BD 135	NPN, 45V, 1.5A
		Q.....7	50-03-0510	BD 136	PNP, 45V, 1.5A
		U.....8	50-03-0515	BC 307B	BC 560B
		Q.....9	50-03-0436	BC 947B	BC 237B, BC 550B
		Q.....10	50-03-0436	BC 947B	BC 237B, BC 550B
		Q.....11	50-03-0515	BC 307B	BC 560B
		Q.....12	50-03-0515	BC 307B	BC 560B
(01)		Q.....13	50-03-0515	BC 307B	BC 560B
		R.....1	57-11-4339	3.3	
		R.....2	57-11-3473	47 k	1%, mf
		R.....3	57-11-3222	2.2 k	1%, mf

S T U D E R (04) 84/09/26 DR SERVO 1 1.769-310.00 PAGE 3

IND.	POS.-NO.	PART NO.	VALUE	SPECIFICATIONS / EQUIVALENT	MANUF.
		R.....4	57-11-4102	1 k	cer
		R.....5	57-11-4474	470 k	cer
		R.....6	57-11-5685	6.8 M	cer
(01)		R.....6	57-11-5565	5.6 M	cer
(00)		R.....7	57-11-5685	6.8 M	cer
(01)		R.....7	57-11-5565	5.6 M	cer
(00)		R.....8	57-11-4273	27 k	cer
(01)		R.....8	57-11-4333	33 k	cer
(00)		R.....9	57-11-4563	56 k	cer
		R.....10	57-11-4334	330 k	cer
		R.....11	57-11-3104	100 k	1%, mf
		R.....12	57-11-3222	2.2 k	1%, mf
		R.....13	57-11-4100	10	cer
		R.....14	57-11-4681	680	cer
		R.....15	57-11-3104	100 k	1%, mf
		R.....16	57-11-3123	12 k	1%, mf
(02)		R.....16	57-11-3622	6.2 k	1%, mf
		R.....17	57-11-4682	6.8 k	cer
		R.....18	57-11-4683	6.8 k	cer
		R.....19	57-11-4223	22 k	cer
		R.....20	57-11-4100	10	cer
		R.....21	57-11-3104	100 k	cer
		R.....22	57-11-4682	6.8 k	cer
		R.....23	57-11-4563	56 k	2%, mf
		R.....24	57-11-4472	4.7 k	cer
		R.....25	57-11-4683	6.8 k	cer
		R.....26	57-11-4563	56 k	2%, mf
		R.....27	57-11-4332	3.3 k	cer
		R.....28	57-11-4272	2.7 k	cer
		R.....29	57-11-4154	150 k	cer
		R.....30	57-11-4101	100	cer
(00)		R.....31	57-11-4102	1 k	cer
(01)		R.....31	57-11-4472	4.7 k	cer
		R.....32	57-11-4472	4.7 k	cer
		R.....33	57-11-4472	4.7 k	cer
		R.....34	57-11-4472	4.7 k	cer
		R.....35	57-11-4472	4.7 k	cer

S T U D E R (04) 84/09/26 DR SERVO 1 1.769-310.00 PAGE 4

IND.	POS.-NO.	PART NO.	VALUE	SPECIFICATIONS / EQUIVALENT	MANUF.
(00)		R.....36	57-11-4161	160	2%, mf
(01)		R.....36	57-11-4541	240	2%, mf
(00)		R.....37	57-11-4751	750	2%, mf
(01)		R.....37	57-11-4112	1.1 k	2%, mf
		R.....38	57-11-4473	47 k	cer
		R.....39	57-11-4103	10 k	cer
		R.....40	57-11-4271	270	2%, mf
		R.....41	57-11-4821	820	2%, mf
		R.....42	57-11-4821	820	2%, mf
		R.....43	57-11-4562	5.6 k	cer
		R.....44	57-11-4103	10 k	cer
		R.....45	57-11-4103	10 k	cer
		R.....46	57-11-4562	5.6 k	cer
		R.....47	57-11-4271	270	2%, mf
(00)		R.....48	57-11-4111	110	2%, mf
(01)		R.....48	57-11-4151	150	2%, mf
(00)		R.....49	57-11-4102	1 k	2%, mf
(01)		R.....49	57-11-4132	1.3 k	2%, mf
(00)		R.....50	57-11-4132	1.3 k	2%, mf
(01)		R.....50	57-11-4132	1.3 k	2%, mf
		R.....51	57-11-4473	47 k	cer
		R.....52	57-11-4133	10 k	cer
		R.....53	57-11-4103	10 k	cer
		R.....54	57-11-4473	47 k	cer
(00)		R.....55	57-11-4111	110	2%, mf
(01)		R.....55	57-11-4151	150	2%, mf
(00)		R.....56	57-11-4121	120	2%, mf
(01)		R.....56	57-11-4241	240	2%, mf
(00)		R.....57	57-11-4162	1.6 k	2%, mf
(01)		R.....57	57-11-4332	3.3 k	2%, mf
(00)		R.....58	57-11-4102	1 k	cer
(01)		R.....58	57-11-4821	820	cer
(00)		R.....59	57-11-4102	1 k	cer
(01)		R.....59	57-11-4472	4.7 k	cer
(01)		R.....60	57-11-4332	3.3 k	cer
(01)		R.....61	57-11-4225	22 k	cer
(01)		R.....62	57-11-4393	39 k	cer

S T U D E R (04) 84/09/26 DR SERVO 1 1.769-310.00 PAGE 5

IND.	POS.-NO.	PART NO.	VALUE	SPECIFICATIONS / EQUIVALENT	MANUF.
		R.....62	57-11-4393		

SERVO 1 PCB 1.769.315-00 "ESE"

FOR LAYOUT SEE 1.769.310 SECTION 5/8

IND.	POS.ND.	PART NO.	VALUE	SPECIFICATIONS / EQUIVALENT	MANUF.	IND.	POS.ND.	PART NO.	VALUE	SPECIFICATIONS / EQUIVALENT	MANUF.
C.....1	59.34.4331	330 p	cer	*** all capacitors 10% ***		R.....11	57.11.3104	100 k	1% mf		
C.....2	59.00.0104	100 n		*** film type unless ***		R.....12	57.11.3223	22 k	1% mf		
C.....3	59.06.0472	4.7 n		*** otherwise noted ***		R.....13	57.11.4100	10			
C.....4	59.06.0223	22 n				R.....14	57.11.4681	680			
C.....5	59.22.8103	10 u	16V, el			R.....15	57.11.3104	100 k	1% mf		
C.....6	59.22.8109	1 u	16V, el			R.....16	57.11.3622	6.2 k	1% mf		
C.....7	59.22.8227	2.2 u	16V, el			R.....17	57.11.4682	6.8 k			
C.....8	59.06.0153	15 n				R.....18	57.11.4683	68 k			
C.....9	59.06.0154	150 n				R.....19	57.11.4223	22 k			
C.....10	59.06.0153	15 n				R.....20	57.11.4100	10			
C.....11	59.06.0473	4.7 n				R.....21	57.11.4104	100 k			
C.....12	59.06.0105	1 u				R.....22	57.11.4682	6.8 k			
C.....13	59.22.5122	1000 u	25V, el			R.....23	57.11.4563	56 k	2% mf		
C.....14	59.22.4472	4700 u	16V, el			R.....24	57.11.4672	4.7 k			
C.....15	59.22.3470	4.7 u	10V, el			R.....25	57.11.4683	68 k			
C.....16	59.06.0223	22 n				R.....26	57.11.4563	56 k	2% mf		
C.....17	59.22.3470	4.7 u	10V, el			R.....27	57.11.4332	3.3 k			
C.....18	59.06.0223	22 n				R.....28	57.11.4272	2.7 k			
C.....19	59.22.3470	4.7 u	10V, el			R.....29	57.11.4154	150 k			
C.....20	59.06.0223	22 n				R.....30	57.11.4101	100			
C.....21	59.22.4470	47 u				R.....31	57.11.4472	4.7 k			
C.....22	59.06.0223	22 n				R.....32	57.11.4472	4.7 k			
C.....23	59.22.5222	2200 u	25V, el			R.....33	57.11.4472	4.7 k			
C.....24	59.22.4470	47 u	16V, el			R.....34	57.11.4472	4.7 k			
C.....25	59.06.0223	22 n				R.....35	57.11.4472	4.7 k			
C.....26	59.22.5222	2200 u	25V, el			R.....36	57.11.4241	240	2% mf		
C.....27	59.22.5220	22 u	25V, el			R.....37	57.11.4112	1.1 k	2% mf		
C.....28	59.06.0223	22 n				R.....38	57.11.4473	47 k			
C.....29	59.22.8101	100 u	50V, 1A			R.....39	57.11.4103	10 k			
C.....30	59.22.5101	100 u	25V, el			R.....40	57.11.4271	270	2% mf		
D.....1	50.04.0125	1N 4448	SI general purpose			R.....41	57.11.4021	820	2% mf		
D.....2	50.04.0125	1N 4448	SI general purpose			R.....42	57.11.4821	820	2% mf		
D.....3	50.04.1103	7.5 V	zener, .4W			R.....43	57.11.4562	5.6 k			
D.....4	50.04.0125	1N 4448	SI general purpose			R.....44	57.11.4103	10 k			
D.....5	50.04.0122	1N 4001	50V, 1A			R.....45	57.11.4103	10 k			
D.....6	50.04.0122	1N 4001	50V, 1A			R.....46	57.11.4562	5.6 k			
D.....6	50.04.0122	1N 4001	50V, 1A			R.....47	57.11.4271	270	2% mf		

S T U D E R (00) 84/11/21 DR SERVO 1 1.769.315.00 PAGE 1 S T U D E R (00) 84/11/21 DR SERVO 1 1.769.315.00 PAGE 4

IND.	POS.ND.	PART NO.	VALUE	SPECIFICATIONS / EQUIVALENT	MANUF.	IND.	POS.ND.	PART NO.	VALUE	SPECIFICATIONS / EQUIVALENT	MANUF.
D.....7	50.04.0122	1N 4001	50V, 1A			R.....48	57.11.4151	150	2% mf		
D.....8	50.04.0122	1N 4001	50V, 1A			R.....49	57.11.4132	1.3 k	2% mf		
D.....9	50.04.0122	1N 4001	50V, 1A			R.....50	57.11.4132	1.3 k	2% mf		
D.....10	50.04.0122	1N 4001	50V, 1A			R.....51	57.11.4473	47 k			
D.....11	50.04.0122	1N 4001	50V, 1A			R.....52	57.11.4103	10 k			
D.....12	50.04.0122	1N 4001	50V, 1A			R.....53	57.11.4103	10 k			
D.....13	50.04.0122	1N 4001	50V, 1A			R.....54	57.11.4473	47 k			
D.....14	50.04.0122	1N 4001	50V, 1A			R.....55	57.11.4151	150	2% mf		
D.....15	50.04.0125	1N 4448	SI general purpose			R.....56	57.11.4241	240	2% mf		
D.....16	50.04.0125	1N 4448	SI general purpose			R.....57	57.11.4302	3 k	2% mf		
D.....17	50.04.0125	1N 4448	SI general purpose			R.....58	57.11.4821	820			
D.....18	50.04.1106	2.7 V	zener, .4W			R.....59	57.11.4472	4.7 k			
DLU...1	50.04.2128	DPB 804	DPTD-COUPLER								
DLU...2	50.04.2128	DPB 804	DPTD-COUPLER								
DZ...1	70.01.0235		B 80 C 3700/2200, RECTIFIER								
IC...1	50.07.0018	HEF 4094	CMOS SHIFT-REGISTER								
IC...2	50.09.0107	RC 4559	DUAL OP-AMP								
IC...3	50.09.0107	RC 4559	DUAL OP-AMP								
IC...4	50.10.0105	LM 337	NEG. VOLTAGE-REGULATOR								
IC...5	50.10.0104	LM 317	POS. VOLTAGE-REGULATOR								
IC...6	50.10.0104	LM 317	POS. VOLTAGE-REGULATOR								
IC...7	50.10.0104	LM 317	POS. VOLTAGE-REGULATOR								
IC...8	50.10.0105	LM 337	NEG. VOLTAGE-REGULATOR								
IC...9	50.10.0105	LM 337	NEG. VOLTAGE-REGULATOR								
J...1	54.01.0291	11 POLE	CIS SOCKET STRIP								
J...2	54.01.0216	6 POLE	CIS SOCKET STRIP								
MP...1	1.769.310.12		SERVO 1-PCB		St						
MP...2	1.769.310.01		HEAT-SINK		St						
MP...3	50.20.2003		CLIP TO 220								
MP...4	50.20.2003		CLIP TO 220								
MP...5	50.20.2003		CLIP TO 220								
MP...6	50.20.2003		CLIP TO 220								

S T U D E R (00) 84/11/21 DR SERVO 1 1.769.315.00 PAGE 2 S T U D E R (00) 84/11/21 DR SERVO 1 1.769.315.00 PAGE 5

IND.	POS.ND.	PART NO.	VALUE	SPECIFICATIONS / EQUIVALENT	MANUF.	IND.	POS.ND.	PART NO.	VALUE	SPECIFICATIONS / EQUIVALENT	MANUF.
MP...7	50.20.2003			CLIP TO 220							
MP...8	50.20.2003			CLIP TO 220							
MP...9	50.20.2002			CLIP TO 126							
MP...10	50.20.2002			CLIP TO 126							
MP...11	21.26.0354			SCREW, CYLIN-HEAD, M3.0*6							
MP...12	21.26.0354			SCREW, CYLIN-HEAD, M3.0*6							
MP...13	24.16.1030			WASHER, D 5.5/3.2							
MP...14	24.16.1030			WASHER, D 5.5/3.2							
MP...15	1.769.310.03			THERMOPLASTIC							
P...1	54.14.2003	26 PIN		FLAT-CABLE PCB-CONNECTOR							
P...2	54.01.0431	11 PIN		CIS STRIP							
P...3	54.01.0431	11 PIN		CIS STRIP							
Q...1	50.03.0436	BC 547B		BC 237B, BC 550B							
Q...2	50.03.0340	BC 337									
Q...3	50.03.0351	BC 327									
Q...4	50.03.0436	BC 547B		BC 237B, BC 550B							
Q...5	50.03.0515	BC 557B		BC 307B, BC 560B							
Q...6	50.03.0495	BU 135		PNP, 45V, 1.5A							
Q...7	50.03.0510	BD 136		PNP, 45V, 1.5A							
Q...8	50.03.0515	BC 557B		BC 307B, BC 560B							
Q...9	50.03.0436	BC 547B		BC 237B, BC 550B							
Q...10	50.03.0436	BC 547B		BC 237B, BC 550B							
Q...11	50.03.0515	BC 557B		BC 307B, BC 560B							
Q...12	50.03.0515	BC 557B		BC 307B, BC 560B							
R...1	57.11.4339	3.3									
R...2	57.11.3223	2.2 k		1% mf *** all resistors 5% .25W ***							
R...3	57.11.3222	1 k		1% mf *** general purpose ***							
R...4	57.11.4102	1 k		*** unless otherwise noted ***							
R...5	57.11.4474	470 k									
R...6	57.11.5565	5.6 M									
R...7	57.11.5565	5.6 M									
R...8	57.11.4333	33 k									
R...9	57.11.4563	56 k									
R...10	57.11.4334	330 k									

S T U D E R (00) 84/11/21 DR SERVO 1 1.769.315.00 PAGE 3

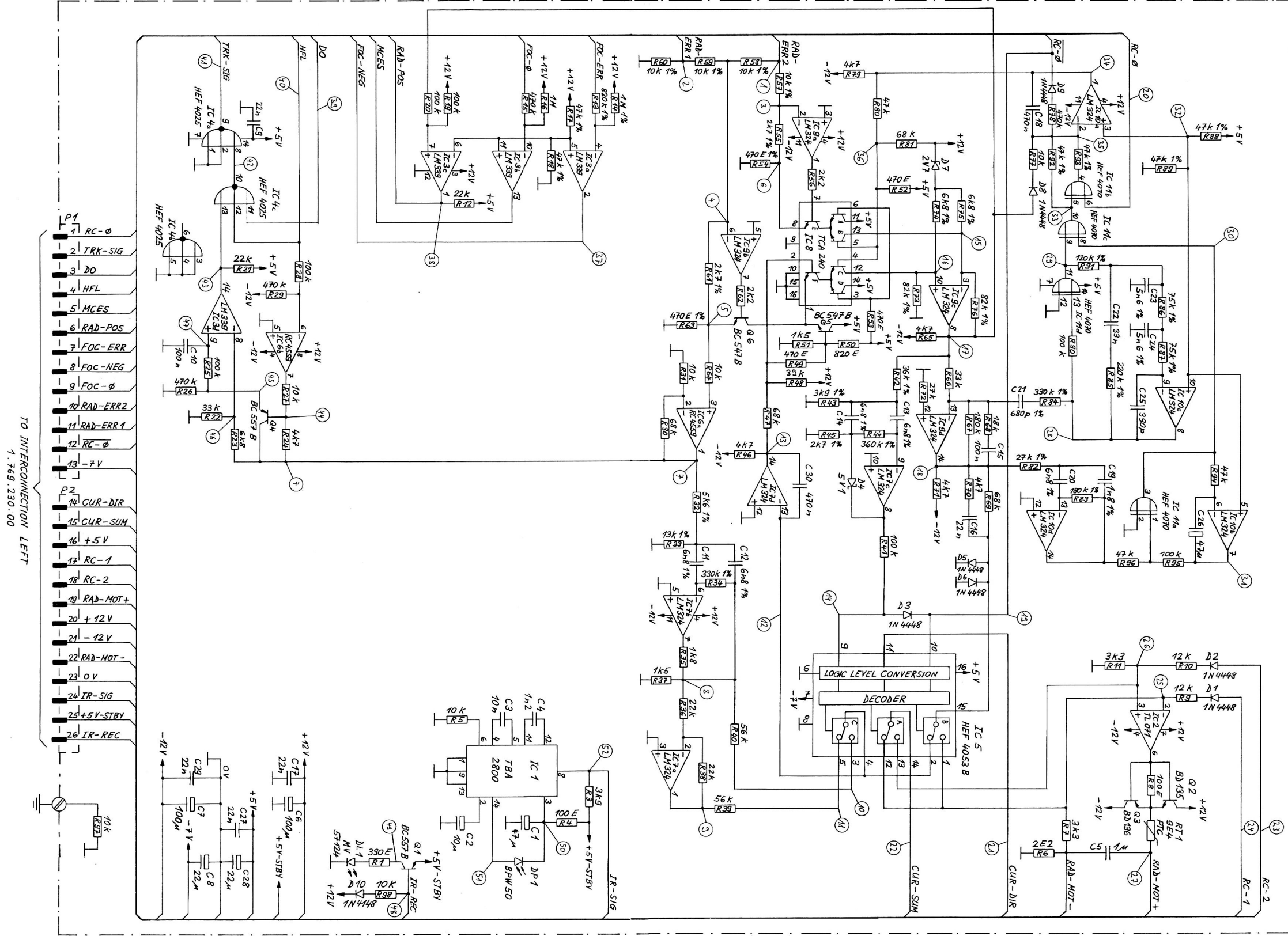

TO INTERCONNECTION LEFT  
1.769.330.00



SERVO 2 PCB 1.769.330-00 "ESE"

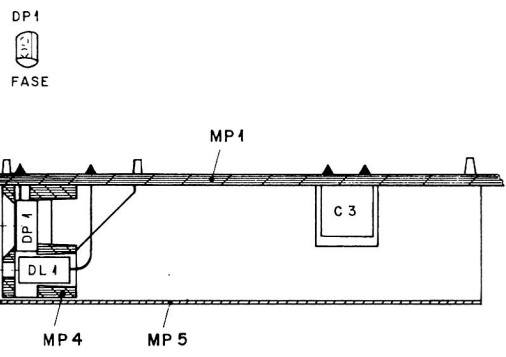
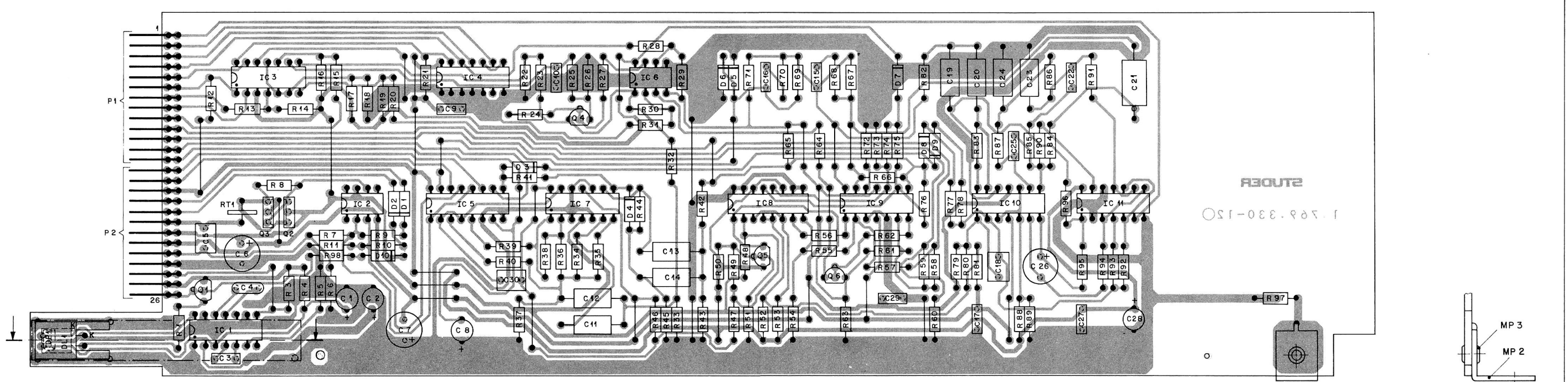

IND.	POS.-NO.	PART NO.	VALUE	SPECIFICATIONS / EQUIVALENT	MANUF.
(00)	C.....1	59-22-5220	22 u	10V, el	all capacitors 10% 50V
(01)	C.....1	59-22-6470	47 u	10V, el	all capacitors 10% 50V
	C.....2	59-22-6100	10 u	10V, el	film type unless
	C.....3	59-06-0103	10 n		otherwise noted
	C.....4	59-32-4123	1.2 n		
	C.....5	59-06-0105	1 u	5%, cer	
(00)	C.....6	59-22-5220	22 u	16V, el	
(01)	C.....6	59-22-4101	100 u	16V, el	
(00)	C.....7	59-22-5220	22 u	16V, el	
(01)	C.....7	59-22-4101	100 u	16V, el	
	C.....8	59-22-5220	22 u	10V, el	
	C.....9	59-06-0223	22 n		
	C.....10	59-06-0104	100 n		
	C.....11	59-12-7682	6.8 n	1%	
	C.....12	59-12-7682	6.8 n	1%	
	C.....13	59-12-7682	6.8 n	1%	
	C.....14	59-12-7682	6.8 n	1%	
	C.....15	59-06-0104	100 n		
	C.....16	59-06-0223	22 n		
	C.....17	59-06-0223	22 n		
	C.....18	59-06-0474	470 n		
	C.....19	59-12-7182	1.8 n	1%	
	C.....20	59-12-7682	6.8 n	1%	
	C.....21	59-12-9681	680 p	1%	
	C.....22	59-06-0333	33 n	1%	
	C.....23	59-12-7562	5.6 n	1%	
	C.....24	59-12-7562	5.6 n	1%	
	C.....25	59-34-5391	390 p	5%, cer	
	C.....26	59-22-4470	47 u	16V, el	
	C.....27	59-06-0223	22 n		
	C.....28	59-22-5220	22 u	16V, el	
	C.....29	59-06-0223	22 n		
	C.....30	59-06-0474	470 n		
	D.....1	50-04-0125	1N 4448	SI general purpose	
	D.....2	50-04-0125	1N 4448	SI general purpose	
	D.....3	50-04-0125	1N 4448	SI general purpose	

STUDER (02) 84/04/02 DR SERVO 2 1.769.330.00 PAGE 1

IND.	POS.-NO.	PART NO.	VALUE	SPECIFICATIONS / EQUIVALENT	MANUF.
	D.....4	50-04-1112	5.1 V	zener, +4W	
	D.....5	50-04-0125	1N 4448	SI general purpose	
	D.....6	50-04-0125	1N 4448	SI general purpose	
	D.....7	50-04-1106	2.7 V	zener, +4W	
	D.....8	50-04-0125	1N 4448	SI general purpose	
	D.....9	50-04-0125	1N 4448	SI general purpose	
(01)	D.....10	50-04-0125	1N 4448	SI general purpose	
	DL.....1	50-04-2119	HV 57124	LED	GI,NS
	DP.....1	50-04-2136	BPH 50	PHOTO DIODE	Ph
	IC.....1	50-11-0121	TBA 2800	IR-RECEIVER	ITT
	IC.....2	50-09-0103	TL 071	OP-AMP	
	IC.....3	50-11-0104	LM 339	DUAL COMPARATOR	
	IC.....4	50-07-0012	HEF 4025	CMOS NOR-GATES	
	IC.....5	50-07-0015	HEF 4053	CMOS ANALOG SWITCHES	
	IC.....6	50-09-0107	RC 4559	DUAL OP-AMP	
	IC.....7	50-05-0199	LM 324	QUAD OP-AMP	
	IC.....8	50-04-0123	TCA 240	BALANCED MODULATOR	
	IC.....9	50-05-0199	LM 324	QUAD OP-AMP	
	IC.....10	50-05-0199	LM 324	QUAD OP-AMP	
	IC.....11	50-07-0070	HEF 4070	CMOS EXOR-GATES	
(00)	MP.....1	1.769.330.11		SERVO 2-PCB	St
(01)	MP.....1	1.769.330.12		SERVO 2-PCB	St
	MP.....2	1.769.280.01		PCB-HOLDER	St
	MP.....3	28.21.1450		TUBULAR RIVET D 3.1*4.0	St
	MP.....4	1.769.330.01		IR-DIODE-SOCKET	St
	MP.....5	1.769.330.02		IR-SHIELD-CASE	St
	P.....1	54-01-0433	13 PIN	C15 STRIP	
	P.....2	54-01-0433	13 PIN	C15 STRIP	
	Q.....1	50-03-0515	BC 557B	BC 560B, BC 307B	
	Q.....2	50-03-0495	BD 135	45V, 1A	
	Q.....3	50-03-0510	BD 136	45V, 1A	

STUDER (02) 84/04/02 DR SERVO 2 1.769.330.00 PAGE 2

IND.	POS.-NO.	PART NO.	VALUE	SPECIFICATIONS / EQUIVALENT	MANUF.
	Q.....4	50-03-0515	BC 557B	BC 560B, BC 307B	
(07)	Q.....5	50-03-0508	MPS 2369	FT 500µHz	Not
(01)	Q.....5	50-03-0436	BC 547B	BC 550B, BC 237B	
	Q.....6	50-03-0436	BC 547B	BC 550B, BC 237B	
	R.....1	57-11-4391	390	all resistors 5% .25W	
(00)	R.....2	57-11-4392	3.9 k	general purpose	
(01)	R.....2	57-11-4392	not used	general purpose	
	R.....3	57-11-4392	3.9 k	general purpose	
	R.....4	57-11-4101	100	unless otherwise noted	
	R.....5	57-11-4103	10 k		
	R.....6	57-11-4229	2.2		
	R.....7	57-11-4332	3.3 k		
	R.....8	57-11-4101	100		
	R.....9	57-11-4123	12 k		
	R.....10	57-11-4123	12 k		
	R.....11	57-11-4332	3.3 k		
	R.....12	57-11-4223	22 k		
	R.....13	57-11-3824	820 k	1%, mf	
	R.....14	57-11-3105	1 M	1%, mf	
	R.....15	57-11-4474	470 k	2%, mf	
	R.....16	57-11-4105	1 M	2%, mf	
	R.....17	57-11-3473	47 k	1%, mf	
	R.....18	57-11-3473	47 k	1%, mf	
	R.....19	57-11-4104	100 k	2%, mf	
	R.....20	57-11-4104	100 k	2%, mf	
	R.....21	57-11-4223	22 k		
	R.....22	57-11-4333	33 k		
	R.....23	57-11-4682	6.8 k		
	R.....24	57-11-4472	4.7 k		
	R.....25	57-11-4104	100 k		
	R.....26	57-11-4474	470 k		
	R.....27	57-11-4103	10 k		
	R.....28	57-11-4104	100 k		
	R.....29	57-11-4474	470 k		
	R.....30	57-11-4683	68 k		
	R.....31	57-11-4103	10 k		

STUDER (02) 84/04/02 DR SERVO 2 1.769.330.00 PAGE 3

IND.	POS.-NO.	PART NO.	VALUE	SPECIFICATIONS / EQUIVALENT	MANUF.
	R.....32	57-11-3562	5.6 k	1%, mf	
	R.....33	57-11-3133	13 k	1%, mf	
	R.....34	57-11-3334	330 k	1%, mf	
	R.....35	57-11-4182	1.8 k		
	R.....36	57-11-4223	22 k		
	R.....37	57-11-4152	1.5 k		
	R.....38	57-11-4223	22 k		
	R.....39	57-11-4563	56 k		
	R.....40	57-11-4563	56 k		
	R.....41	57-11-4104	100 k		
	R.....42	57-11-3363	36 k	1%, mf	
	R.....43	57-11-3392	3.9 k	1%, mf	
	R.....44	57-11-3364	360 k	1%, mf	
	R.....45	57-11-3272	2.7 k	1%, mf	
	R.....46	57-11-4472	4.7 k		
	R.....47	57-11-4683	68 k		
(00)	R.....48	57-11-3623	62 k	1%, mf	
(02)	R.....48	57-11-4393	39 k		
	R.....49	57-11-4471	470		
	R.....50	57-11-4821	820		
	R.....51	57-11-4152	1.5 k		
	R.....52	57-11-4471	470		
	R.....53	57-11-4471	470		
	R.....54	57-11-3471	470	1%, mf	
	R.....55	57-11-3272	2.7 k	1%, mf	
	R.....56	57-11-4222	2.2 k		
	R.....57	57-11-3103	10 k	1%, mf	
	R.....58	57-11-3103	10 k	1%, mf	
	R.....59	57-11-3103	10 k	1%, mf	
	R.....60	57-11-3103	10 k	1%, mf	
	R.....61	57-11-3272	2.7 k	1%, mf	
	R.....62	57-11-4222	2.2 k		
	R.....63	57-11-3471	470	1%, mf	
	R.....64	57-11-4103	10 k		
	R.....65	57-11-4472	4.7 k		
	R.....66	57-11-4333	33 k		
	R.....67	57-11-4184	180 k		

STUDER (02) 84/04/02 DR SERVO 2 1.769.330.00 PAGE 4

IND.	POS.-NO.	PART NO.	VALUE	SPECIFICATIONS / EQUIVALENT	MANUF.
	R.....68	57-11-4183	18 k		
	R.....69	57-11-4683	68 k		
	R.....70	57-11-4472	4.7 k		
	R.....71	57-11-4472	4.7 k		
	R.....72	57-11-4273	27 k		
	R.....73	57-11-3623	62 k	1%, mf	
	R.....74	57-11-3682	6.8 k	1%, mf	
	R.....75	57-11-3682	6.8 k	1%, mf	
	R.....76	57-11-3823	82 k	1%, mf	
	R.....77	57-11-4103	10 k		
	R.....78	57-11-4474	470 k		
	R.....79	57-11-4472	4.7 k		
	R.....80	57-11-4473	47 k		
	R.....81	57-11-4683	68 k	1%, mf	
	R.....82	57-11-3273	27 k	1%, mf	
	R.....83	57-11-3184	180 k	1%, mf	
	R.....84	57-11-3334	330 k	1%, mf	
	R.....85	57-11-3224	220 k	1%, mf	
	R.....86	57-11-3753	75 k	1%, mf	
	R.....87	57-11-3753	75 k	1%, mf	
	R.....88	57-11-3473	47 k	1%, mf	
	R.....89	57-11-3473	47 k	1%, mf	
	R.....90	57-11-4104	100 k		
	R.....91	57-11-3124	120 k	1%, mf	
	R.....92	57-11-3473	47 k	1%, mf	
	R.....93	57-11-3473	47 k	1%, mf	
	R.....94	57-11-4473	47 k	1%, mf	
	R.....95	57-11-4104	100 k		
	R.....96	57-11-4473	47 k		
	R.....97	57-11-4103	10 k		
(01)	R.....98	57-11-4103	10 k		
	RT.....1	57-99-0222	9.4	PTC	
(00)	RT.....2	57-99-0222	9.4	PTC	
(01)	RT.....2	57-99-0222	9.4	not used	

STUDER (02) 84/04/02 DR SERVO 2 1.769.330.00 PAGE 5

IND.	POS.-NO.	PART NO.	VALUE	SPECIFICATIONS / EQUIVALENT	MANUF.
	R.....99	57-11-3562	5.6 k	1%, mf	
	R.....100	57-11-3133	13 k	1%, mf	
	R.....101	57-11-3334	330 k	1%, mf	
	R.....102	57-11-4182	1.8 k		
	R.....103	57-11-4223	22 k		
	R.....104	57-11-4152	1.5 k		
	R.....105	57-11-4223	22 k		
	R				

MICROPROCESSOR PCB 1.769.320-00 "ESE"

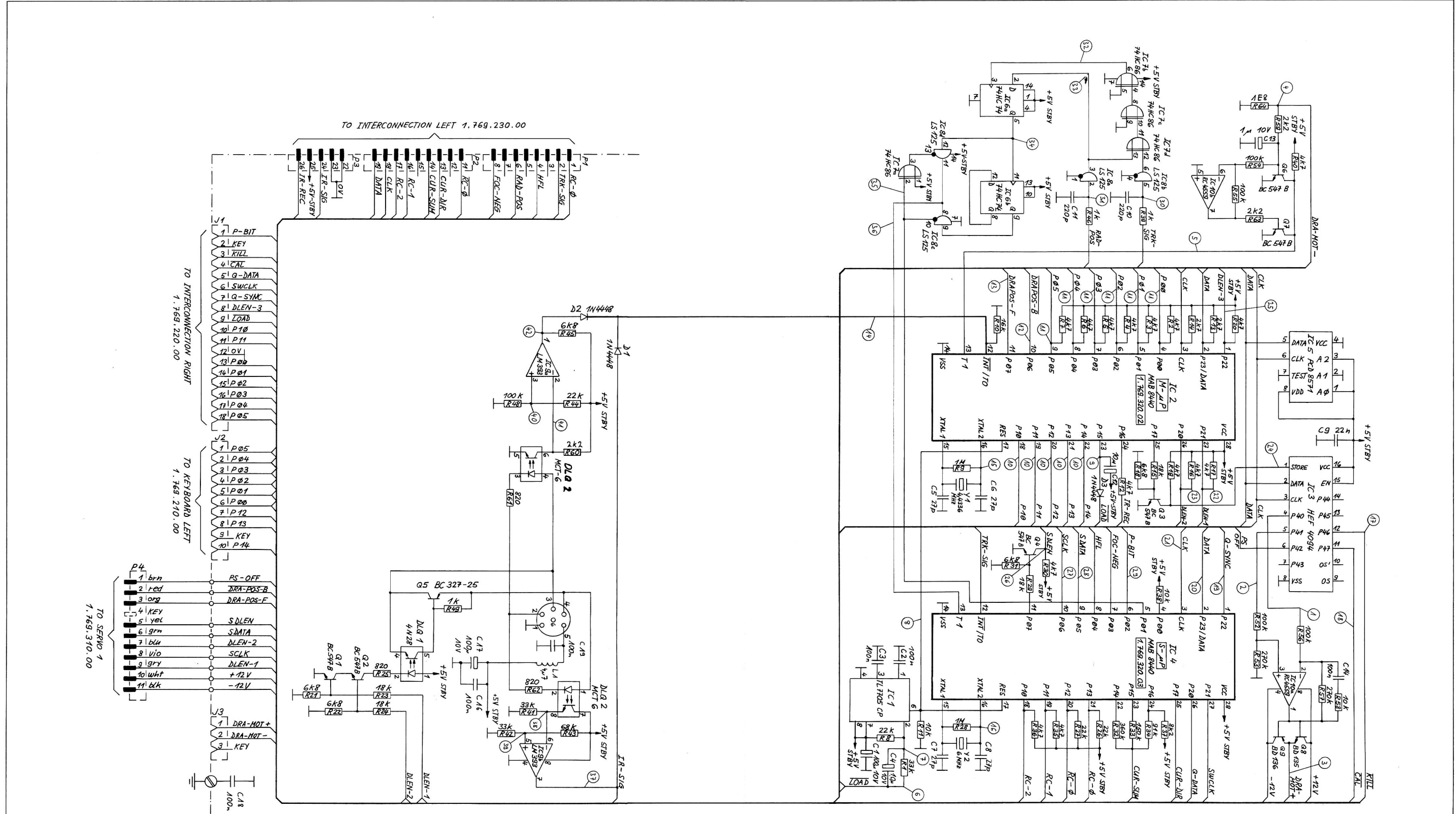

11.11.83 GP	© 12.3.85 DR	B 225 COMPACT-DISC-PLAYER		
STUDER	MICROPROCESSOR PCB "ESE"	SC 1.769.320.00	PAGE 2 OF 2	

11.11.83 GP	© 12.3.85 DR	B 225 COMPACT-DISC-PLAYER		
STUDER	MICROPROCESSOR PCB "ESE"	SC 1.769.320.00	PAGE 1 OF 2	

MICROPROCESSOR PCB 1.769.320-00 "ESE"

IND.	POS.NO.	PART NO.	VALUE	SPECIFICATIONS / EQUIVALENT	MANUF.	IND.	POS.NO.	PART NO.	VALUE	SPECIFICATIONS / EQUIVALENT	MANUF.	IND.	POS.NO.	PART NO.	VALUE	SPECIFICATIONS / EQUIVALENT	MANUF.	IND.	POS.NO.	PART NO.	VALUE	SPECIFICATIONS / EQUIVALENT	MANUF.
(00)	C.....1	59.22.3470	47 uF	10 V, el		IC.....7	50.17.1086	74 HC 86	74 LS 86	BUFFER		Q.....9	50.03.0510	BD 136	PNP, 45 V, 1.5 A		R.....36	57.11.4472	4.7 kOhm		R.....36	57.11.4472	4.7 kOhm
(02)	C.....1	59.22.3101	100 uF	10 V, el		IC.....8	50.06.0125	LS 125		DUAL-COMPARATOR		R.....1	57.11.4333	33 kOhm	*** all resistors 5 ± 0.25 W ***		R.....37	57.11.4822	8.2 kOhm		R.....37	57.11.4822	8.2 kOhm
(00)	C.....2	59.06.0104	100 nF	10X film type		IC.....9	50.05.0283	LM 393		DUAL-OP-AMP		R.....2	57.11.4472	4.7 kOhm	*** general purpose ***		R.....38	57.11.4103	10 kOhm		R.....38	57.11.4103	10 kOhm
(00)	C.....3	59.06.0102	1 nF	10X film type		IC.....10	50.09.0107	RC 4559				R.....3	57.11.4472	4.7 kOhm	*** unless otherwise noted ***		R.....39	57.11.4102	1 kOhm		R.....39	57.11.4102	1 kOhm
(06)	C.....4	59.06.0104	100 nF	10X film type		J.....1	54.01.0247	18 POLE	C15 SOCKET STRIP			R.....4	57.11.4472	4.7 kOhm		R.....40	57.11.4472	4.7 kOhm		R.....40	57.11.4472	4.7 kOhm	
	C.....5	59.22.6100	10 uF	10 V, el		J.....2	54.01.0307	10 POLE	C15 SOCKET STRIP			R.....5	57.11.4472	4.7 kOhm		R.....41	57.11.4333	33 kOhm		R.....41	57.11.4333	33 kOhm	
	C.....6	59.34.2270	27 pF	cer		J.....3	54.01.0249	3 POLE	C15 SOCKET STRIP			R.....6	57.11.4472	4.7 kOhm		R.....42	57.11.4333	33 kOhm		R.....42	57.11.4333	33 kOhm	
	C.....7	59.34.2270	27 pF	cer		J.....4	54.20.2001	6 POLE	DIN JACK SOCKET			R.....7	57.11.4472	4.7 kOhm		R.....43	57.11.4683	68 kOhm		R.....43	57.11.4683	68 kOhm	
	C.....8	59.34.2270	27 pF	cer		(02) L.....1	62.02.3479	4.7 uH				R.....8	57.11.4223	22 kOhm		R.....44	57.11.4683	68 kOhm		R.....44	57.11.4683	68 kOhm	
	C.....9	59.06.0223	22 nF	10X film type		(00) MP.....1	1.769.320.11		MICROPROCESSOR-PCB	St		R.....9	57.11.4105	1 kOhm		R.....45	57.11.4682	6.8 kOhm		R.....45	57.11.4682	6.8 kOhm	
	C.....10	59.34.4221	220 pF	cer		(01) MP.....1	1.769.320.12		MICROPROCESSOR-PCB	St		R.....10	57.11.4103	10 kOhm		R.....46	57.11.4102	1 kOhm		R.....46	57.11.4102	1 kOhm	
	C.....11	59.34.4221	220 pF	cer		(02) MP.....1	1.769.320.13		MICROPROCESSOR-PCB	St		R.....11	57.11.4103	10 kOhm		R.....47	57.11.4474	470 kOhm		R.....47	57.11.4474	470 kOhm	
(00)	C.....12	59.34.4151	150 pF	cer		(00) MP.....2	1.769.320.14		PCB-HOLDER	St		R.....12	57.11.4472	4.7 kOhm		(00) R.....48	57.11.4102	1 kOhm		(00) R.....48	57.11.4102	1 kOhm	
(01)	C.....12	59.22.6100	10 uF	10 V, el		(02) MP.....1	1.769.320.13		MICROPROCESSOR-PCB	St		R.....13	57.11.4272	2.7 kOhm		(01) R.....48	57.11.4104	100 kOhm		(01) R.....48	57.11.4104	100 kOhm	
	C.....13	59.22.6109	1 uF	10 V, el		MP.....3	28.21.1450		TUBULAR RIVET D 3.1x4.0			R.....14	57.11.4272	2.7 kOhm		(00) R.....49	57.11.4333	33 kOhm		(00) R.....49	57.11.4333	33 kOhm	
	C.....14	59.06.0104	100 nF	10X film type		MP.....4	1.769.320.93		WIRING-LIST MICROPROCESSOR-BOARD	St		R.....15	57.11.4183	18 kOhm		(01) R.....49	57.11.4102	1 kOhm		(01) R.....49	57.11.4102	1 kOhm	
(00)	C.....15	59.06.0102	1 nF	10X film type		MP.....5	54.01.0229	11 POLE	C15 PIN CASE			R.....16	57.11.4472	4.7 kOhm		(00) R.....50	57.11.4682	6.8 kOhm		(00) R.....50	57.11.4682	6.8 kOhm	
(01)	C.....15	59.06.0104	100 nF	10X film type		(00) MP.....6	35.03.0109		TY-RAP, PLASTIC			R.....17	57.11.4472	4.7 kOhm		(01) R.....50	57.11.4682	6.8 kOhm		(01) R.....50	57.11.4682	6.8 kOhm	
(02)	C.....16	59.22.3101	100 uF	10V, el		(02) MP.....6			not used		R.....18	57.11.4682	6.8 kOhm		(00) R.....51	57.11.4103	10 kOhm		(00) R.....51	57.11.4103	10 kOhm		
(02)	C.....17	59.22.3101	100 uF	10V, el		(02) MP.....7			TY-RAP, PLASTIC		R.....19	57.11.4472	4.7 kOhm		(01) R.....51	57.11.4103	10 kOhm		(01) R.....51	57.11.4103	10 kOhm		
(02)	C.....18	59.06.0104	100 nF	10X film type		(02) MP.....7			not used		R.....20	57.11.4472	4.7 kOhm		(01) R.....51	57.11.4103	10 kOhm		(01) R.....51	57.11.4103	10 kOhm		
(02)	C.....19	59.06.0104	100 nF	10X film type		P.....1	54.01.0428	8 PIN	C15 STRIP		R.....21	57.11.4682	6.8 kOhm		R.....52	57.11.4104	100 kOhm		R.....52	57.11.4104	100 kOhm		
	D.....1	50.04.0125	1N 4448	general purpose		P.....2	54.01.0429	9 PIN	C15 STRIP		R.....22	57.11.4682	6.8 kOhm		R.....53	57.11.4274	270 kOhm		R.....53	57.11.4274	270 kOhm		
	D.....2	50.04.0125	1N 4448	general purpose		P.....3	54.01.0425	5 PIN	C15 STRIP		R.....23	57.11.4183	18 kOhm		R.....54	57.11.4104	100 kOhm		R.....54	57.11.4104	100 kOhm		
(01)	D.....3	50.04.0125	1N 4448	general purpose		Q.....1	50.03.0436	BC 547 B	BC 237 B, BC 550 B		R.....24	57.11.4183	18 kOhm		R.....55	57.11.4104	100 kOhm		R.....55	57.11.4104	100 kOhm		
	DLQ.....1	50.99.0126	4 N 28	DPTD-COUPLER		Q.....2	50.03.0436	BC 547 B	BC 237 B, BC 550 B		R.....25	57.11.4223	22 kOhm		R.....56	57.11.4104	100 kOhm		R.....56	57.11.4104	100 kOhm		
	DLQ.....2	50.99.0111	HCT 6	DUAL-DPTD-COUPLER		Q.....3	50.03.0436	BC 547 B	BC 237 B, BC 550 B		R.....26	57.11.4223	22 kOhm		R.....57	57.11.4274	270 kOhm		R.....57	57.11.4274	270 kOhm		
	IC.....1	50.11.0122	TL 7705	CP RESET-GENERATOR		Q.....4	50.03.0436	BC 547 B	BC 237 B, BC 550 B		R.....27	57.11.4223	22 kOhm		R.....58	57.11.4103	10 kOhm		R.....58	57.11.4103	10 kOhm		
	IC.....2	1.769.320.02	8440	M-MICROCOMPUTER	St	Q.....5	50.03.0515	BC 557 B	BC 307 B, BC 560 B		R.....28	57.11.4105	1 kOhm		R.....59	57.11.4222	2.2 kOhm		R.....59	57.11.4222	2.2 kOhm		
	IC.....3	50.07.0018	HEF 4094	CMOS-SHIFT-REGISTER		(01) Q.....5	50.03.0351	BC 327-2	5		R.....29	57.11.4183	18 kOhm		(00) R.....60	57.11.4102	1 kOhm		(00) R.....60	57.11.4102	1 kOhm		
	IC.....4	1.769.320.03	8440	S-MICROCOMPUTER	St	Q.....6	50.03.0436	BC 547 B	BC 237 B, BC 550 B		R.....30	57.11.4472	4.7 kOhm		(01) R.....60	57.11.4472	4.7 kOhm		(01) R.....60	57.11.4472	4.7 kOhm		
	IC.....5	50.14.0123	PCD 8571	CMOS-RAM 128x8		Q.....7	50.03.0436	BC 547 B	BC 237 B, BC 550 B		R.....31	57.11.4682	6.8 kOhm		(05) R.....60	57.11.4222	2.2 kOhm		(05) R.....60	57.11.4222	2.2 kOhm		
	IC.....6	50.17.1074	74 LS 74	74 LS 74		Q.....8	50.03.0495	BD 135	PNP, 45 V, 1.5 A		R.....32	57.11.4366	360 kOhm		(00) R.....61	57.11.4122	1.2 kOhm		(00) R.....61	57.11.4122	1.2 kOhm		
											R.....33	57.11.4154	150 kOhm		(01) R.....61	57.11.4821	820 Ohm		(01) R.....61	57.11.4821	820 Ohm		
											R.....34	57.11.4913	91 kOhm		R.....62	57.11.4821	820 Ohm		R.....62	57.11.4821	820 Ohm		
											R.....35	57.11.4472	4.7 kOhm		R.....63	57.11.4222	2.2 kOhm		R.....63	57.11.4222	2.2 kOhm		

S T U D E R (06) 85/03/12 DR MICROPROZESSOR-BOARD 1.769.320.00 PAGE 1 S T U D E R (06) 85/03/12 DR MICROPROZESSOR-BOARD 1.769.320.00 PAGE 2 S T U D E R (06) 85/03/12 DR MICROPROZESSOR-BOARD 1.769.320.00 PAGE 3 S T U D E R (06) 85/03/12 DR MICROPROZESSOR-BOARD 1.769.320.00 PAGE 4

IND.	POS.NO.	PART NO.	VALUE	SPECIFICATIONS / EQUIVALENT	MANUF.
(09)	X.....4	53.03.0173	XTC DIL 28-pin		
(02)	X.....2	53.03.0173	XTC DIL 28-pin		
(03)	X.....4	53.03.0173	XTC DIL 28-pin		
(03)	X.....5			not used	
	Y.....1	49.01.0554	4.433619 MHz	HC18U QUARZ	
	Y.....2	49.01.0551	4.433619 MHz	HC18U QUARZ	

(01) 10.01.84 modification after 0-serie  
 (02) 23.03.84 Funkschutzzeichen  
 (03) 06.04.85  
 (04) 06.04.84 Berichtigung  
 (05) 29.06.84  
 (06) 12.03.85 reset-problems during power-on  
 MANUFACTURER: St-Studer  
 DR10 83/10/13 (01) 84/01/10 (02) 84/03/23 (03) 84/04/06 (04) 84/04/06  
 (05) 84/06/28 (06) 85/03/12  
 S T U D E R (06) 85/03/12 DR MICROPROZESSOR-BOARD 1.769.320.00 PAGE 5

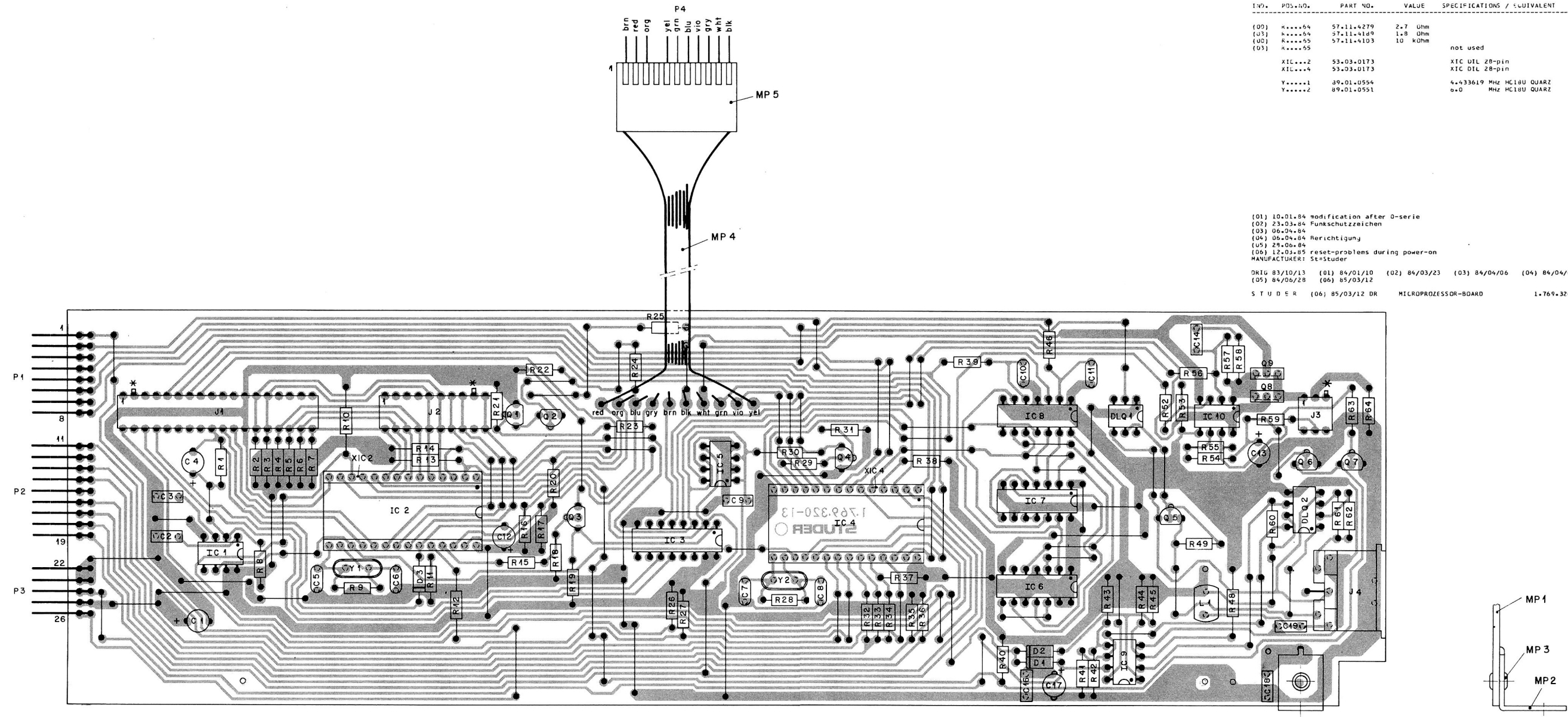



LCD PCB 1.769.250-00 "ESE"

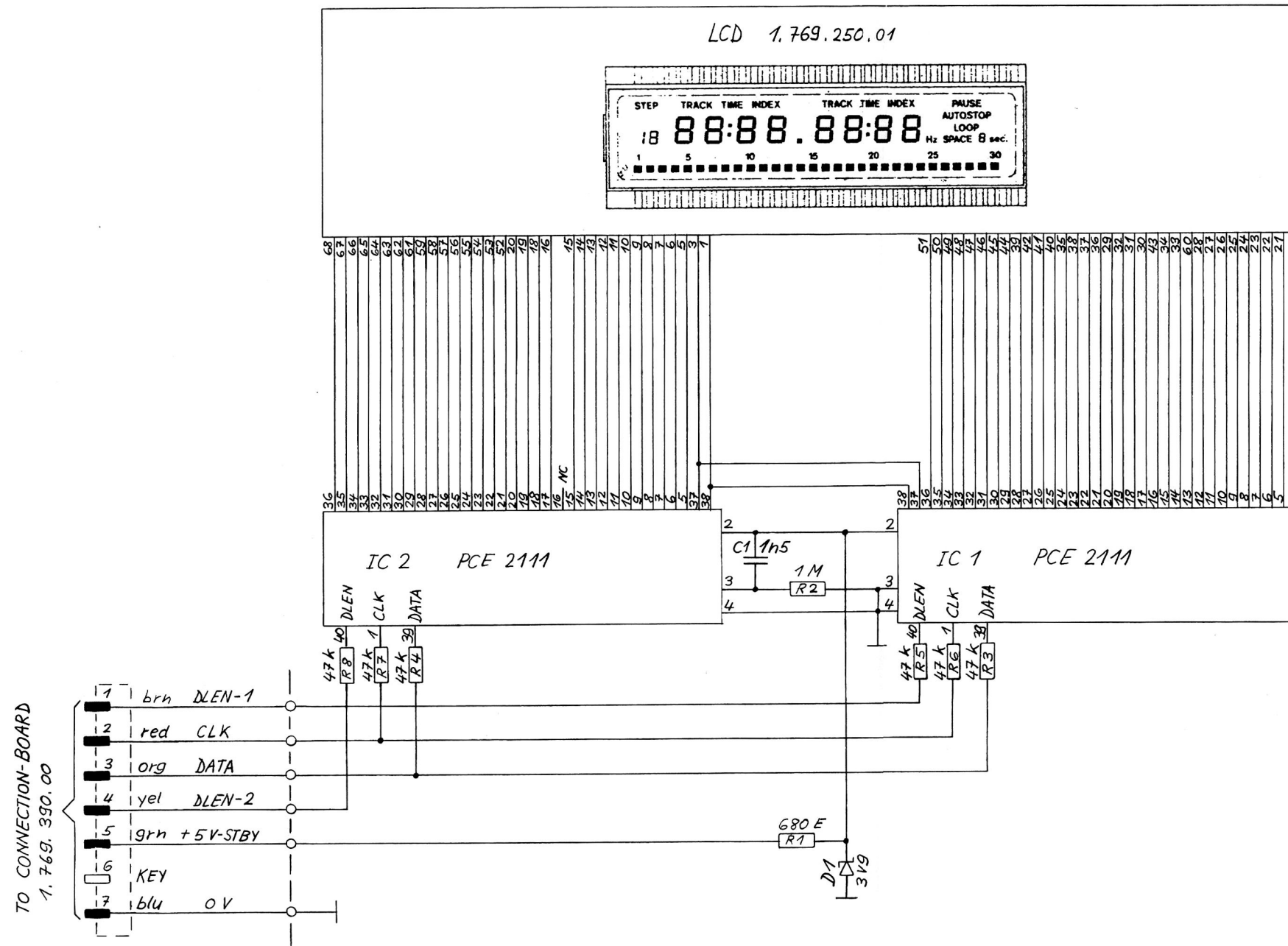

24.10.83 GP	B225 COMPACT-DISC-PLAYER	PAGE 1 OF 1
STUDER	LCD - BOARD	SC 1.769.250.00



LCD PCB 1.769.250-00 "ESE"

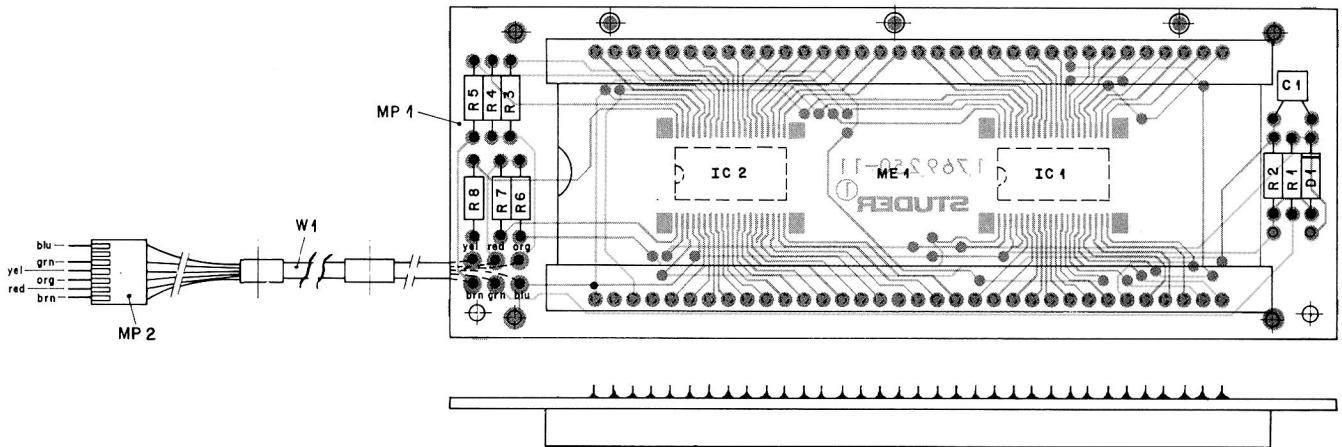

IND.	POS.-NO.	PART NO.	VALUE	SPECIFICATIONS / EQUIVALENT	MANUF.
	C..0001	59.32.4152	1.5 n	ceramic, 50V, 20%	
	D..0001	50.04.1101	3.9 V	zener, .4W	
	IC.0001	50.16.0112	PCE 2111	LCD-DRIVER	
	IC.0002	50.16.0112	PCE 2111	LCD-DRIVER	
	ME.0001	1.769.250.01		LCD	
	MP.0001	1.769.250.11		LCD-PCB	St
	MP.0002	59.01.0233	7 POLE	CIS PIN CASE	
(00)	MP.0003	35.03.0109		TY-RAP, PLASTIC	
(01)	MP.0003			not used	
(00)	MP.0004	35.03.0109		TY-RAP, PLASTIC	
(01)	MP.0004			not used	
(00)	MP.0005	35.03.0109		TY-RAP, PLASTIC	
(01)	MP.0005			not used	
(00)	MP.0006	35.03.0109		TY-RAP, PLASTIC	
(01)	MP.0006			not used	
(01)	MP.0007	1.769.100.45		BLENDE	
(00)	MP.0008	20.21.7102		SCREW	
(01)	MP.0009	20.21.7102		SCREW	
(01)	MP.0010	20.21.7102		SCREW	
	R..0001	57.11.4481	680	*** all resistors 5% ***	
	R..0002	57.11.5105	1 M		
	R..0003	57.11.4473	47 k		
	R..0004	57.11.4473	47 k		
	R..0005	57.11.4473	47 k		
	R..0006	57.11.4473	47 k		
	R..0007	57.11.4473	47 k		
	R..0008	57.11.4473	47 k		
	W..0001	1.769.250.93		WIRING-LIST LCD-BOARD	St

S T U D E R (01) 84/05/15 DR LCD-BOARD 1.769.250.00 PAGE 1

IND. POS.-NO. PART NO. VALUE SPECIFICATIONS / EQUIVALENT MANUF.  
 (01) 15.05.84  
 MANUFACTURER: St=Studer

CONNECTION PCB 1.769.390-00/-81/395-00

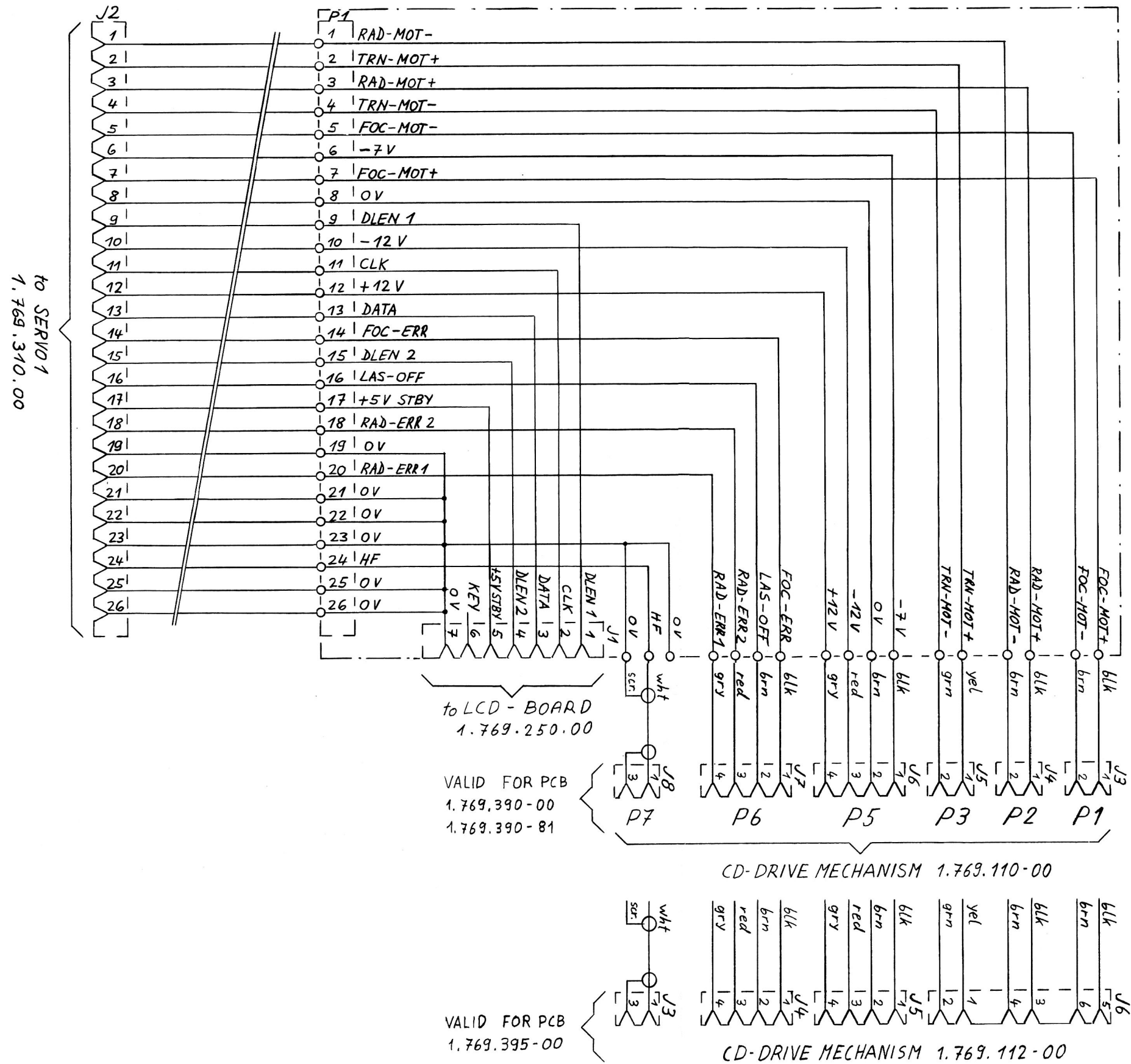

TO SERVO 1  
1.769.310.00

to LCD - BOARD  
1.769.250.00

VALID FOR PCB  
1.769.390-00  
1.769.390-81

VALID FOR PCB  
1.769.395-00

CD-DRIVE MECHANISM 1.769.110-00

CD-DRIVE MECHANISM 1.769.112-00

16.03.84 GP	B 225 COMPACT-DISC-PLAYER	PAGE 1 OF 1
STUDER	CONNECTION - BOARD	SC 1.769.390.81

CONNECTION PCB 1.769.390-00/-81

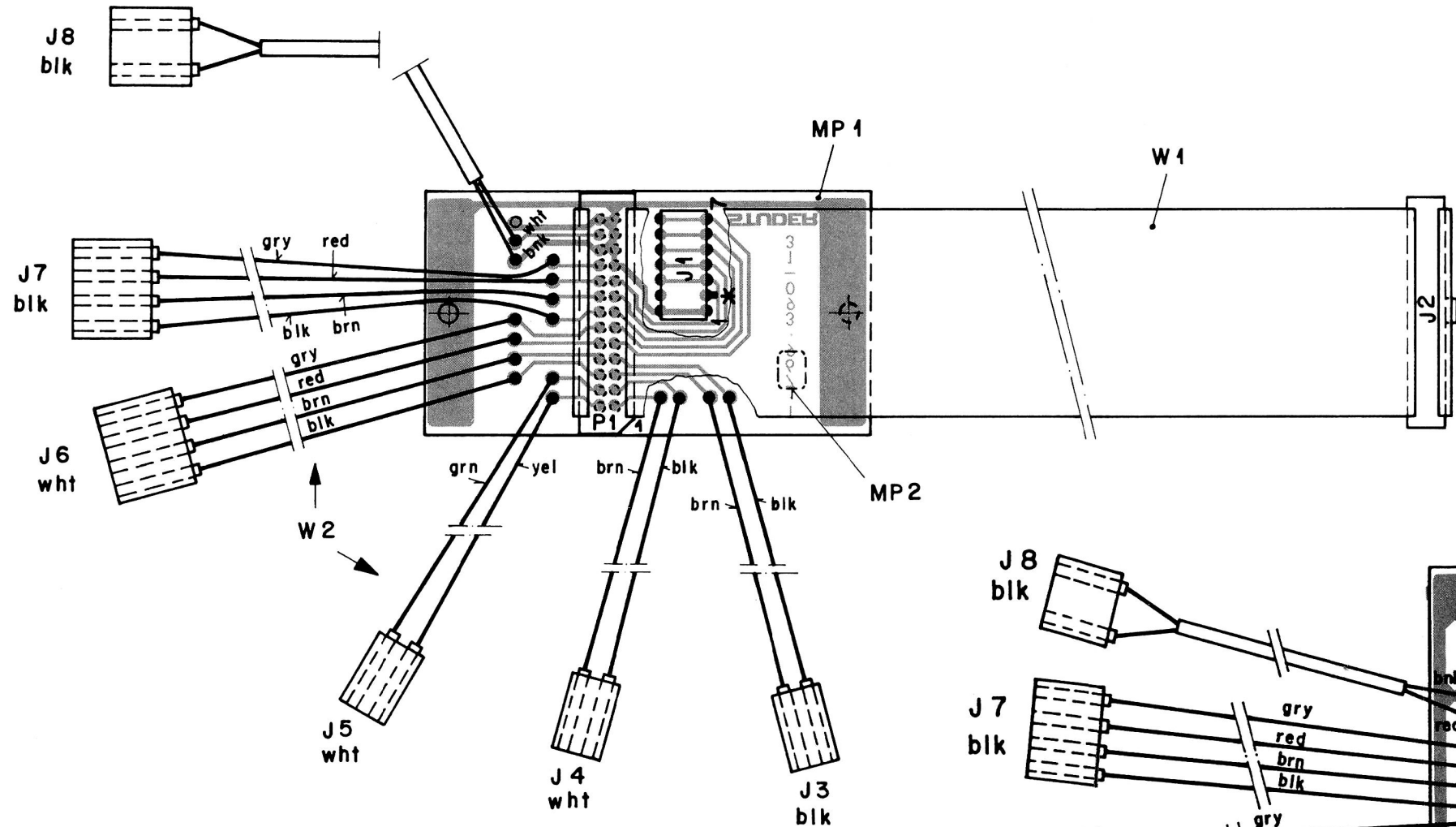

IND.	POS.NO.	PART NO.	VALUE	SPECIFICATIONS / EQUIVALENT	MANUF.
	J1-0001	54-01-0244	7 POLE	CIS SOCKET STRIP	
	MP-0001	1-769-390-13		CONNECTION-PCB	St
	MP-0002	1-010-081-43		MODIFICATION-LABEL	St
(01)	MP-0003	1-769-390-90		ISOLIERSCHLAUCHLISTE	St
	W1-0001	1-023-112-05		FLAT-CABLE 26-CONDUCTORS	St
	W1-0002			WIRES OF 1.769-100-35	

(01) 26-06-86  
 MANUFACTURER: St-Studer  
 ORIG 84/03/16 (01) 84/06/26  
 S T U D E R (01) 84/06/26 DR CONNECTION-BOARD 1.769-390-81 PAGE 1

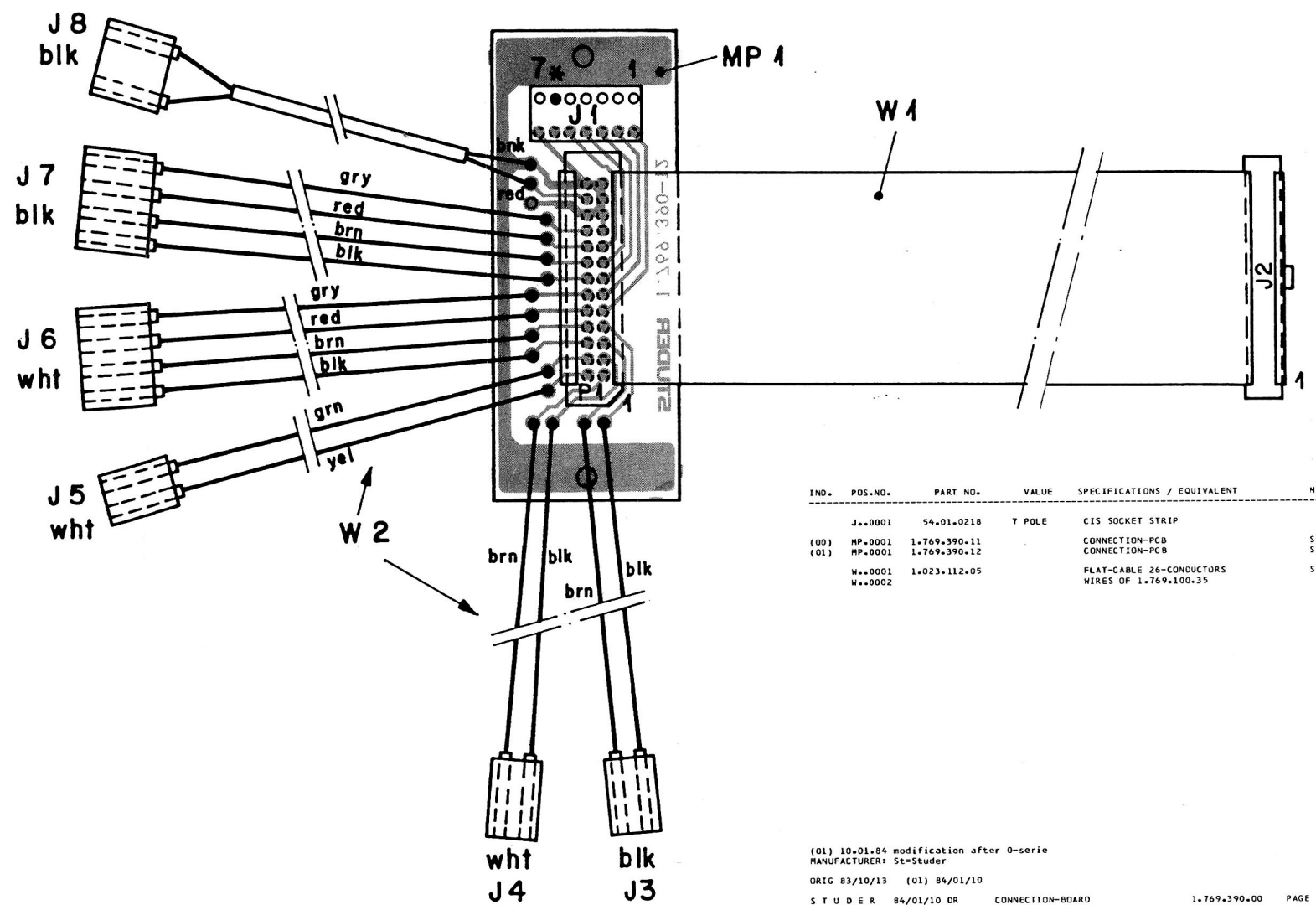

IND.	POS.NO.	PART NO.	VALUE	SPECIFICATIONS / EQUIVALENT	MANUF.
	J1-0001	54-01-0218	7 POLE	CIS SOCKET STRIP	
(00)	MP-0001	1-769-390-11		CONNECTION-PCB	St
(01)	MP-0001	1-769-390-12		CONNECTION-PCB	St
	W1-0001	1-023-112-05		FLAT-CABLE 26-CONDUCTORS	St
	W1-0002			WIRES OF 1.769-100-35	

(01) 10-01-86 modification after 0-serie  
 MANUFACTURER: St-Studer  
 ORIG 83/10/13 (01) 84/01/10  
 S T U D E R 84/01/10 DR CONNECTION-BOARD 1.769-390-00 PAGE 1

CONNECTION PCB 1.769.395-00

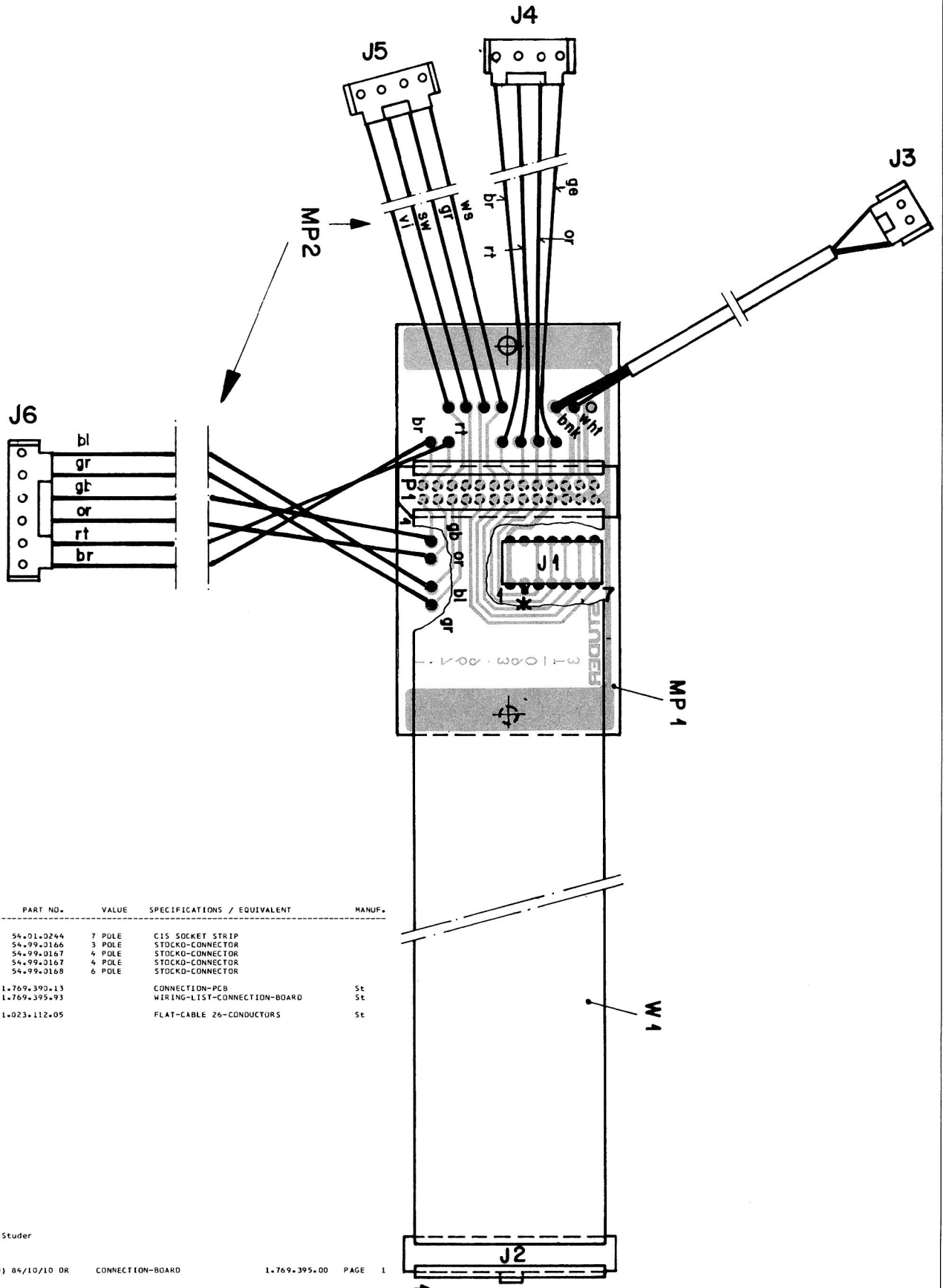

IN°.	POS. NO.	PART NO.	VALUE	SPECIFICATIONS / EQUIVALENT	MANUF.
J.....1		54.01.0244	7 POLE	C15 SOCKET STRIP	
J.....3		54.99.0166	3 POLE	STOCKO-CONNECTOR	
J.....4		54.99.0167	4 POLE	STOCKO-CONNECTOR	
J.....5		54.99.0167	4 POLE	STOCKO-CONNECTOR	
J.....6		54.99.0168	6 POLE	STOCKO-CONNECTOR	
MP.....1		1.769.395.13		CONNECTION-PCB	St
MP.....2		1.769.395.93		WIRING-LIST-CONNECTION-BOARD	St
W.....1		1.023.112.05		FLAT-CABLE 26-CONDUCTORS	St

MANUFACTURER: St=Studer

DRIG 84/10/10

S T U D E R (00) 84/10/10 DR CONNECTION-BOARD

1.769.395.00 PAGE 1

CD-DRIVE MECHANISM 1.769.110-00 "ESE"

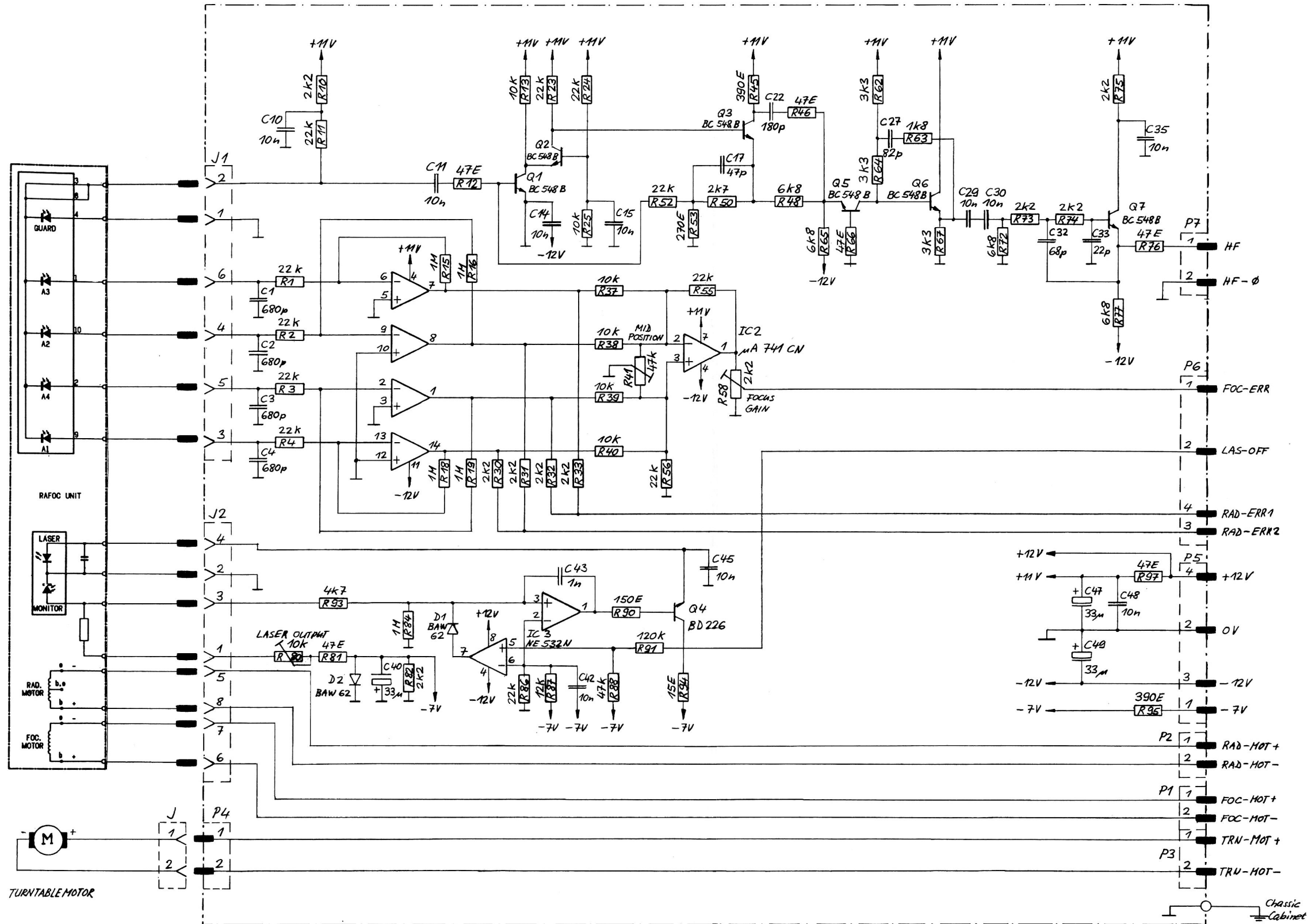

© 28.10.83 D. & S. B225 COMPACT DISC PLAYER  
 STUDER PREAMPLIFIER + LASER - BOARD SC 1.769.100.35 PAGE 1 OF 1

CD-DRIVE MECHANISM 1.769.112 "ESE"

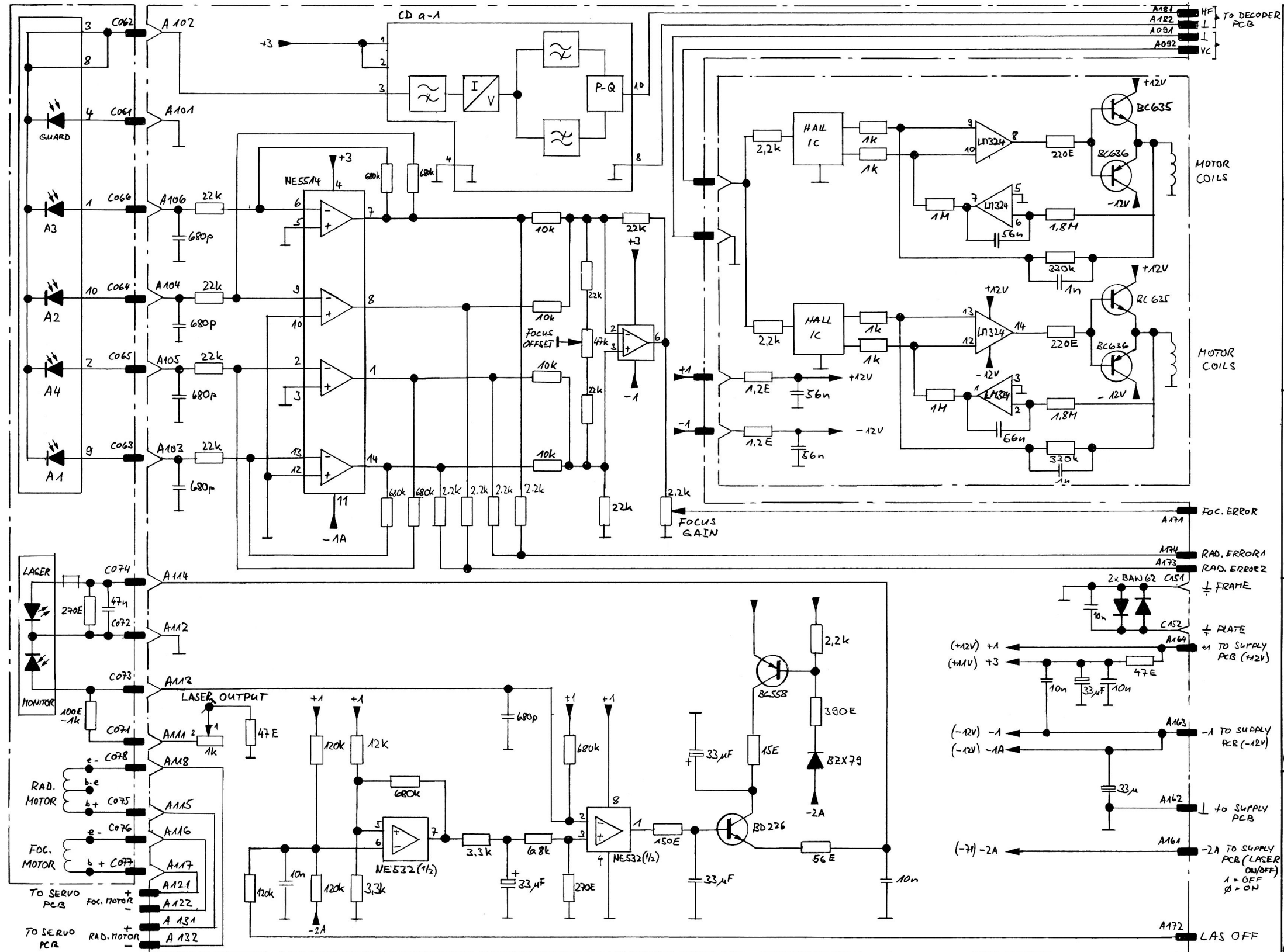

07.02.85  
 B225 COMPACT DISC PLAYER  
 PREAMPLIFIER+LASER PCB  
 STUDER  
 PAGE 1 OF 1  
 SC 1.769.100.36

INTERCONNECTION PCB RIGHT 1.769.220-00

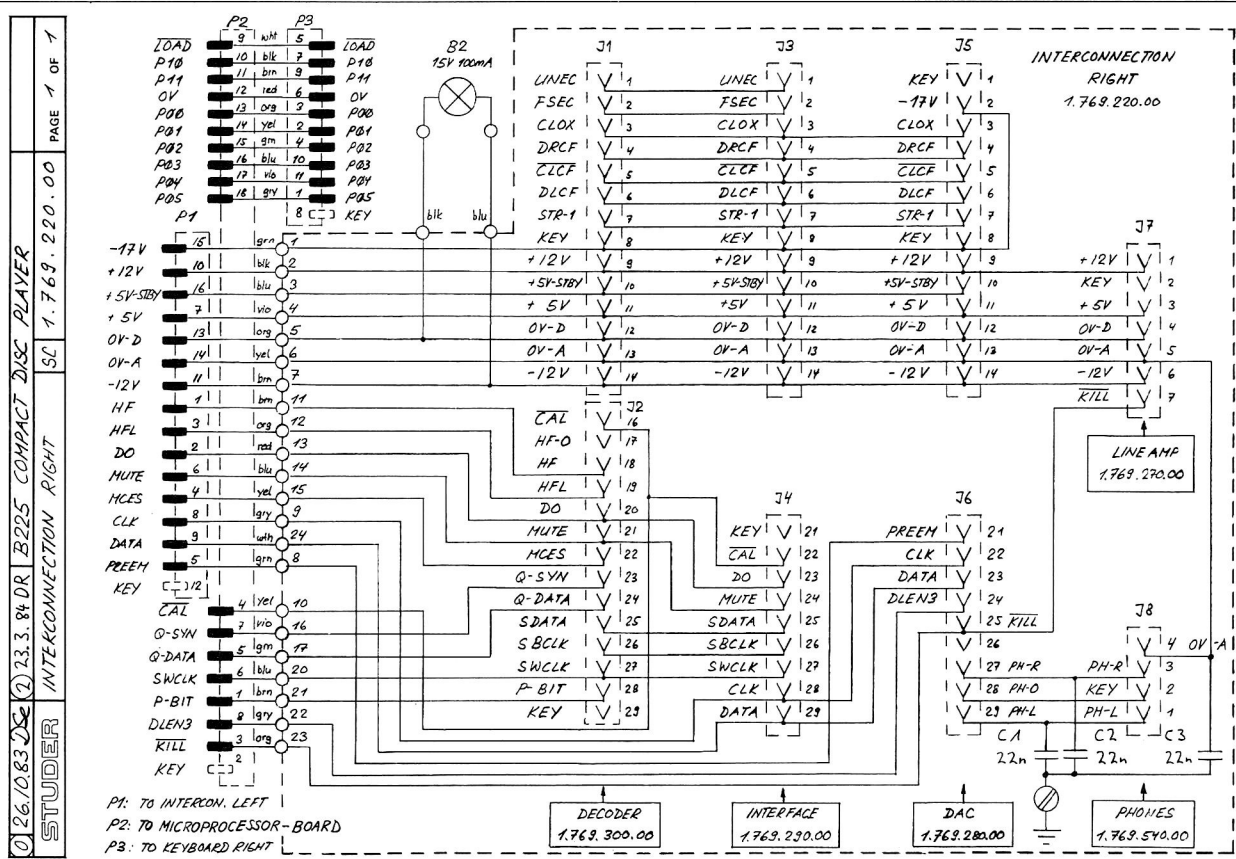

01261083 DSE 1) 23.3.84 DR B225 COMPACT DISC PLAYER  
 STUDER INTERCONNECTION RIGHT  
 SL 1.769.220.00  
 PAGE 1 OF 1

P1: TO INTERCON. LEFT  
 P2: TO MICROPROCESSOR-BOARD  
 P3: TO KEYBOARD RIGHT

POS	SIGNAL	COLOR	CONNECTOR	CONNECTOR	CONNECTOR	PRINT CON
W 1	NAME		P 1	P 2	P 3	MP 1
1	HF	BRN	1			11
2	DO	RED	2			13
3	HFL	ORG	3			12
4	MCES	YEL	4			15
5	PREEM	GRN	5			8
6	MUTE	BLU	6			14
7	+5V	VIO	7			4
8	CLK	GRY	8			9
9	DATA	WTH	9			24
10	+12V	BLK	10			2
11	-12V	BRN	11			7
12	OV-D	ORG	13			5
13	OV-A	YEL	14			6
14	-18V	GRN	15			1
15	+5V-STBY	BLU	16			3
16	P-BIT	BRN		1		21
17	KILL	ORG		3		23
18	CAL	YEL		4		10
19	Q-DATA	GRN		5		17
20	SWCLK	BLU		6		20
21	Q-SYN	VIO		7		16
22	DLEN3	GRY		8		22
23	LOAD	WHT		9	5	
24	P10	BLK		10	7	
25	P11	BRN		11	9	
26	OV	RED		12	6	
27	P00	ORG		13	3	
28	P01	YEL		14	2	
29	P02	GRN		15	4	
30	P03	BLU		16	10	
31	P04	VIO		17	11	
32	P05	GRY		18	1	



INTERCONNECTION PCB RIGHT 1.769.220-00

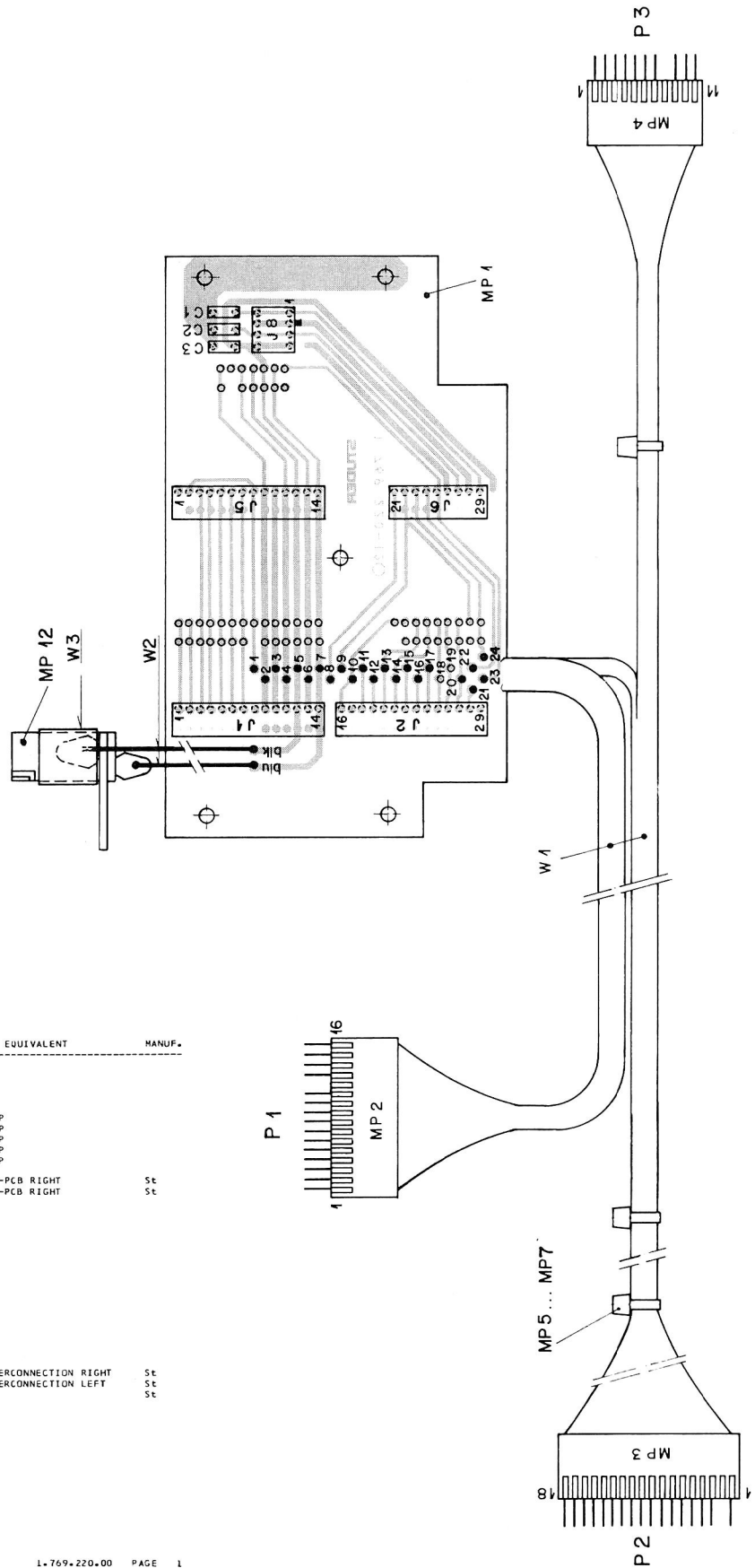

IND.	POS. NO.	PART NO.	VALUE	SPECIFICATIONS / EQUIVALENT	MANUF.
(03)	C..0001	59.06.0223	22 n		
(03)	C..0002	59.06.0223	22 n		
(03)	C..0003	59.06.0223	22 n		
	J..0001	54.01.0300	14 POLE	CIS SOCKET STRIP	
	J..0002	54.01.0300	14 POLE	CIS SOCKET STRIP	
	J..0005	54.01.0300	14 POLE	CIS SOCKET STRIP	
	J..0006	54.01.0235	9 POLE	CIS SOCKET STRIP	
	J..0008	54.01.0304	4 POLE	CIS SOCKET STRIP	
(07)	MP..0001	1.769.220-11		INTERCONNECTION-PCB RIGHT	St
(03)	MP..0001	1.769.220-12		INTERCONNECTION-PCB RIGHT	St
	MP..0002	54.01.0283	16 POLE	CIS PIN CASE	
	MP..0003	54.01.0267	18 POLE	CIS PIN CASE	
	MP..0004	54.01.0229	11 POLE	CIS PIN CASE	
	MP..0005	35.03.0109		TY-RAP, PLASTIC	
	MP..0006	35.03.0109		TY-RAP, PLASTIC	
	MP..0007	35.03.0109		TY-RAP, PLASTIC	
(00)	MP..0006	35.03.0109		TY-RAP, PLASTIC	
(01)	MP..0008			not used	
(00)	MP..0009	35.03.0109		TY-RAP, PLASTIC	
(01)	MP..0009			not used	
(00)	MP..0010	35.03.0109		TY-RAP, PLASTIC	
(01)	MP..0010			not used	
(00)	MP..0011	35.03.0109		TY-RAP, PLASTIC	
(01)	MP..0011			not used	
(02)	MP..0012	53.04.0121		LAMP-CONNECTOR	
	W..0001	1.769.220-93		WIRING-LIST INTERCONNECTION RIGHT	St
(04)	W..0002	1.769.230-93		WIRING-LIST INTERCONNECTION LEFT	St
(04)	W..0003	1.010.132-05		SHRINKING-TUBE	St

(01) 10.01.84 modification after 0-serie  
 (02) 17.02.84  
 (03) 23.03.84 Funkschutzzeichen  
 (04) 17.04.85  
 MANUFACTURER: St=Studer



DECODER PCB 1.769.300-00 "ESE"

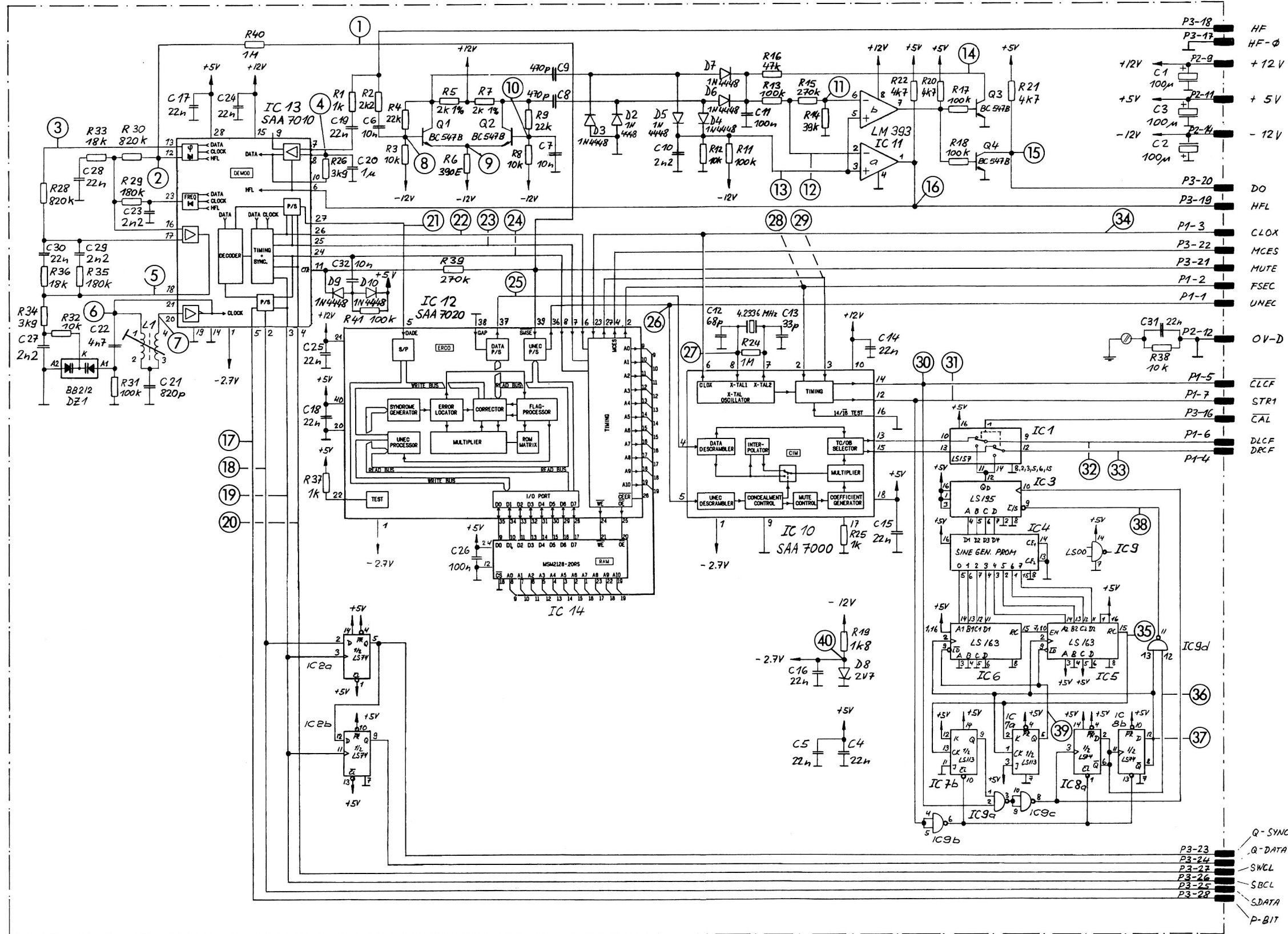

① 22.09.83 Dse	10.1.84 GP	COMPACT DISC PLAYER B225	SC 1.769.300.00	PAGE 1 OF 1
<b>STUDER</b>			DECODER	

- P3-23 Q-SYNC
- P3-24 Q-DATA
- P3-27 SWCL
- P3-26 SBCL
- P3-25 S-DATA
- P3-28 P-BIT

DECODER PCB 1.769.300-00 "ESE"

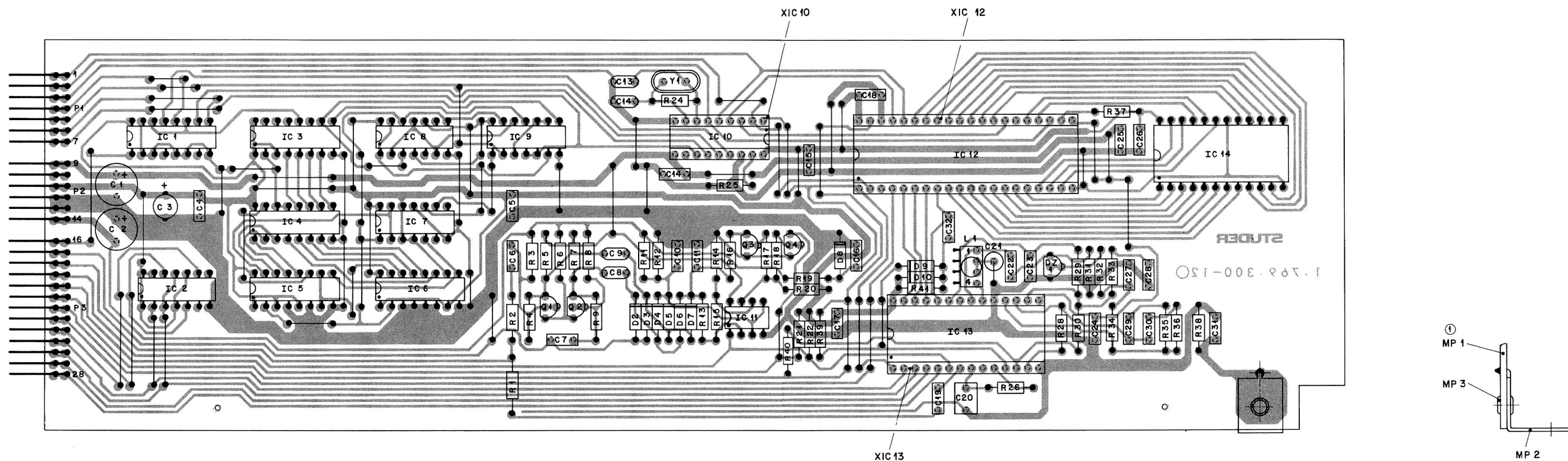

IND.	POS.NO.	PART NO.	VALUE	SPECIFICATIONS / EQUIVALENT	MANUF.	IND.	POS.NO.	PART NO.	VALUE	SPECIFICATIONS / EQUIVALENT	MANUF.	IND.	POS.NO.	PART NO.	VALUE	SPECIFICATIONS / EQUIVALENT	MANUF.	IND.	POS.NO.	PART NO.	VALUE	SPECIFICATIONS / EQUIVALENT	MANUF.
(00)	C..0001	59.22.5220	22 u	25V + e1		(01)	D..0001		not used	*** all diodes SI general purpose ***		P..0003	54.01.0433	13 PIN	CIS STRIP		R..0032	57.11.4103	10 k				
(01)	C..0001	59.22.4101	100 u	16V + e1		D..0002	50.04.0125	1N4448		*** all diodes SI general purpose ***		R..0001	50.03.0436	BC 237B	BC 547B, BC 550B		R..0033	57.11.4183	18 k				
(00)	C..0002	59.22.5220	22 u	25V + e1		D..0003	50.04.0125	1N4448				Q..0001	50.03.0436	BC 237B	BC 547B, BC 550B		R..0034	57.11.4392	3.9 k				
(01)	C..0002	59.22.4101	100 u	16V + e1		D..0004	50.04.0125	1N4448				Q..0002	50.03.0436	BC 237B	BC 547B, BC 550B		R..0035	57.11.4184	180 k				
(00)	C..0003	59.22.5220	22 u	25V + e1		D..0005	50.04.0125	1N4448				Q..0003	50.03.0436	BC 237B	BC 547B, BC 550B		R..0036	57.11.4183	18 k				
(01)	C..0003	59.22.3101	100 u	10V + e1		D..0006	50.04.0125	1N4448				Q..0004	50.03.0436	BC 237B	BC 547B, BC 550B		R..0037	57.11.4102	1.0 k				
(01)	C..0004	59.06.0223	22 n	*** all capacitors 10% 50V ***		D..0007	50.04.0125	1N4448				R..0001	57.11.4102	1.0 k	*** all resistors 10% ***	(01)	R..0039	57.11.4274	270 k				
C..0005	59.06.0223	22 n		*** film type ***		D..0008	50.04.1106	2.7 V		5%, .40W, zener		R..0002	57.11.4222	2.2 k	*** general purpose ***	(01)	R..0040	57.11.4105	1 M				
C..0006	59.06.0103	10 n		*** unless otherwise noted ***		(01)	D..0009	50.04.0125	1N4448			R..0003	57.11.4103	10 k	*** unless otherwise ***	(01)	R..0041	57.11.4104	100 k				
C..0007	59.06.0103	10 n				(01)	D..0010	50.04.0125	1N4448			R..0004	57.11.4223	22 k	*** noted ***								
C..0008	59.34.5471	470 p	cer			D..0011	50.99.0165	BB 212, DUAL VARICAP DIODE		PH		R..0005	57.11.3202	2 k	1%	XIC0010	53.03.0175	XIC DIL 18-pin					
C..0009	59.34.5471	470 p	cer			IC..0001	50.17.1157	74HC157		HCMOS *** HCMOS= high-speed CMOS ***		R..0006	57.11.4391	390	1%	XIC0012	53.03.0172	XIC DIL 40-pin					
C..0010	59.06.0222	2.2 n				IC..0002	50.17.1074	74HC074		HCMOS *** see note 1) below ***		R..0007	57.11.3202	2 k	1%	XIC0013	53.03.0173	XIC DIL 28-pin					
C..0011	59.06.0104	100 n				IC..0003	50.17.1195	74HC195		SINE-PRDM, compact disc	St	R..0008	57.11.4103	10 k		Y..0001	89.01.0555	4.2336 MHZ, QUARTZ		Ph			
C..0012	59.34.4680	68 p	cer			IC..0004	1.025.026.80	1KHZ 00B				R..0009	57.11.4223	22 k									
C..0013	59.34.2330	33 p	cer			IC..0005	50.17.1163	74HC163				R..0010	57.11.4332	3.3 k	not used								
C..0014	59.06.0223	22 n				IC..0006	50.17.1163	74HC163				R..0011	57.11.4104	100 k									
C..0015	59.06.0223	22 n				IC..0007	50.17.1113	74HC113				R..0012	57.11.4103	10 k									
C..0016	59.06.0223	22 n				IC..0008	50.17.1074	74HC074				R..0013	57.11.4104	100 k									
C..0017	59.06.0223	22 n				IC..0009	50.17.1000	74HC000				R..0014	57.11.4393	39 k									
C..0018	59.06.0223	22 n				IC..0010	50.13.0109	SA 7000		Conc. Interpol.+ Muting	Ph	R..0015	57.11.4274	270 k									
C..0019	59.06.0223	22 n				IC..0011	50.05.0283	LW 393 N		Error-Correction	Ph	R..0016	57.11.4473	47 k									
C..0020	59.06.0105	1.0 u				IC..0012	50.13.0111	SA 7020		Demodulator	Ph	R..0017	57.11.4104	100 k									
C..0021	59.04.7821	820 p				IC..0013	50.13.0110	SA 7010		HM 6116 LP-3,MSM 5128-15, RAM 2K08	Ph	R..0018	57.11.4104	100 k									
C..0022	59.06.5472	4.7 n	5%			IC..0014	50.14.0107	MSM2128				R..0019	57.11.4182	1.8 k									
C..0023	59.06.5222	2.2 n	5%			L..0001	62.99.0110	7..8 uH		INDUCTOR	Ph	R..0020	57.11.4472	4.7 k									
C..0024	59.06.0223	22 n				(00)	MP..0001	1.769.300.11		DECODER-PCB	St	R..0021	57.11.4472	4.7 k									
C..0025	59.06.0223	22 n				(01)	MP..0001	1.769.300.12		DECODER-PCB	St	R..0022	57.11.4105	1 M									
C..0026	59.06.0104	100 n					MP..0002	1.769.280.01		PCB-HOLDER	St	R..0023	57.11.4102	1.0 k									
C..0027	59.06.5222	2.2 n	5%				MP..0003	28.21.1450		TUBULAR RIVET D 3.104.0	St	R..0024	57.11.4392	3.9 k									
C..0028	59.06.5223	22 n	5%				P..0001	54.01.0427		CIS STRIP		R..0025	57.11.4824	820 k									
C..0029	59.06.5222	2.2 n	5%				P..0002	54.01.0426		CIS STRIP		R..0026	57.11.4184	180 k									
C..0030	59.06.5223	22 n	5%									R..0027	57.11.4824	820 k									
C..0031	59.06.0223	22 n										R..0028	57.11.4184	180 k									
(01)	C..0032	59.06.0103	10 n									R..0029	57.11.4184	180 k									
(00)	D..0001	50.04.0125	1N4448	*** all diodes SI general purpose ***								R..0030	57.11.4824	820 k									
												R..0031	57.11.4104	100 k									

DAC PCB 1.769.280-00 "ESE"

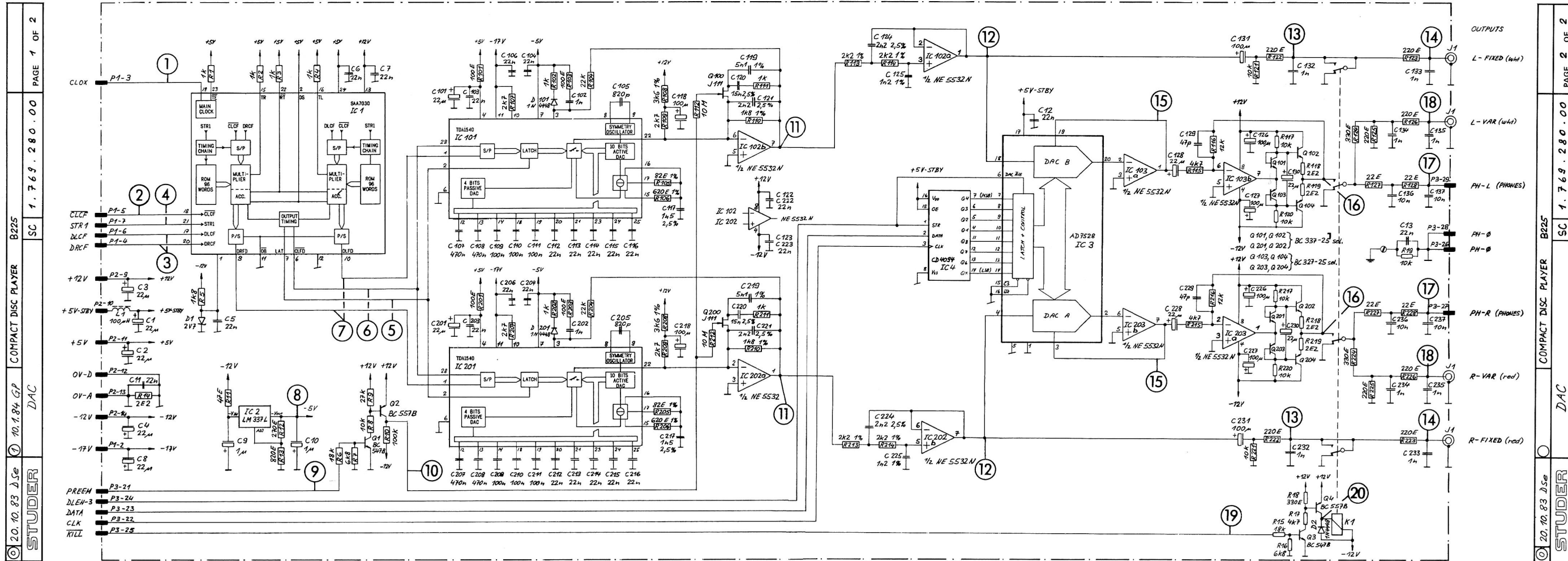

© 20.10.83 J.S. STUDER  
 10.1.84 G.P. COMPACT DISC PLAYER B225 SC 1.769.280.00 PAGE 1 OF 2  
 DAC

COMPACT DISC PLAYER B225 SC 1.769.280.00 PAGE 2 OF 2  
 DAC



DAC PCB 1.769.280-00 "ESE"

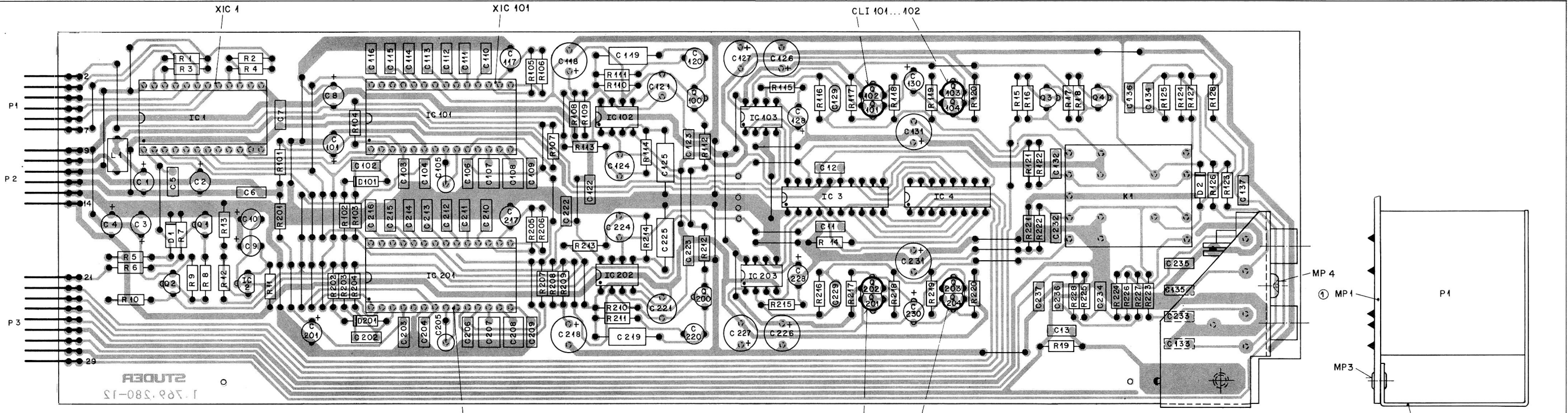

IND.	POS-NO.	PART NO.	VALUE	SPECIFICATIONS / EQUIVALENT	MANUF.	IND.	POS-NO.	PART NO.	VALUE	SPECIFICATIONS / EQUIVALENT	MANUF.	IND.	POS-NO.	PART NO.	VALUE	SPECIFICATIONS / EQUIVALENT	MANUF.	IND.	POS-NO.	PART NO.	VALUE	SPECIFICATIONS / EQUIVALENT	MANUF.	
C..0001	59.22.5220	22	u	e1 *** all capacitors 10% 25V ***		C..0215	59.06.0223	22	n			Q..0002	50.03.0515	BC 557B	BC 307B, BC 560B	R..0214	57.11.3222	2-2	k	1%, metal film				
C..0002	59.22.5220	22	u	e1 *** film type ***		C..0216	59.06.0223	22	n	2.5%		Q..0003	50.03.0436	BC 547B	9C 237B, BC 550B	R..0215	57.11.4472	4-7	k	2%				
C..0003	59.22.5220	22	u	e1 *** unless otherwise noted ***		C..0217	59.05.2152	1-5	n	1%		Q..0004	50.03.0515	BC 557B	BC 307B, BC 560B	R..0216	57.11.4123	12	k	2%				
C..0004	59.22.5220	22	u			(01) C..0218	59.22.4101	100	u	e1	16V vel	Ph	Q..0101	50.03.0516	BC 337	NPN, 1) see note below	Six							
C..0005	59.06.0223	22	n			C..0219	59.12.7512	5-1	n	1%		Q..0102	50.03.0516	BC 337	NPN, 1) see note below	Six								
C..0006	59.06.0223	22	n			C..0220	59.05.2153	15	n	2.5%		Q..0104	50.03.0625	BC 327	PNP, 2) see note below	Six								
C..0007	59.06.0223	22	n			C..0221	59.05.2222	2-2	n	2.5%		Q..0200	50.03.0216	J 111	ND-FET, Rds(on) < 30 ohm	Six								
C..0008	59.22.5220	22	u	e1		C..0222	59.06.0223	22	n			Q..0201	50.03.0516	BC 337	NPN, 1) see note below	Six								
C..0009	59.22.8109	1-0	u	e1		C..0223	59.06.0223	22	n	2.5%		Q..0202	50.03.0516	BC 337	NPN, 1) see note below	Six								
C..0010	59.22.8109	1-0	u	e1		C..0224	59.05.2222	2-2	n	1%		Q..0203	50.03.0625	BC 327	PNP, 2) see note below	Six								
C..0011	59.06.0223	22	n			C..0225	59.12.7122	1-2	n	1%		Q..0204	50.03.0625	BC 327	PNP, 2) see note below	Six								
C..0012	59.06.0223	22	n			(01) C..0226	59.22.5101	100	u	e1	16V vel	R..0001	57.11.4102	1-0	k	*** all resistors 5% ***								
C..0013	59.06.0223	22	n			C..0227	59.22.4101	100	u	e1	16V vel	R..0002	57.11.4102	1-0	k	*** general purpose ***								
C..0014	59.06.0223	22	n			C..0228	59.22.5220	22	u	e1	*** unless otherwise noted ***	R..0003	57.11.4102	1-0	k									
C..0015	59.04.7821	820	n	5%		C..0229	59.34.2470	47	p	cer		R..0004	57.11.4102	1-0	k									
C..0016	59.06.0223	22	n			C..0230	59.22.5220	22	u	e1		R..0005	57.11.4182	1-8	k									
C..0017	59.06.0474	470	n			(01) C..0231	59.22.5101	100	u	e1		R..0006	57.11.4183	18	k									
C..0018	59.06.0474	470	n			C..0232	59.05.2102	1-0	n			R..0007	57.11.4682	6-8	k									
C..0019	59.06.0104	100	n			(01) C..0233	59.05.2102	1-0	n			R..0008	57.11.4103	10	k									
C..0020	59.06.0104	100	n			C..0234	59.05.2102	1-0	n			R..0009	57.11.4273	27	k									
C..0021	59.06.0223	22	n			(01) C..0235	59.05.2102	1-0	n			R..0010	57.11.4104	100	k									
C..0022	59.06.0223	22	n			C..0236	59.05.2103	10	n			R..0011	57.11.4670	4-7	k									
C..0023	59.06.0223	22	n			(01) C..0237	59.06.0103	10	n	16V vel		R..0012	57.11.4221	2-2	k									
C..0024	59.06.0223	22	n			C..0238	59.05.2103	10	n			R..0013	57.11.4682	6-8	k									
C..0025	59.06.0223	22	n			(01) C..0239	59.06.0103	10	n	16V vel		R..0014	57.11.4220	22	k									
C..0026	59.06.0223	22	n			C..0240	59.05.2103	10	n			R..0015	57.11.4183	18	k									
C..0027	59.06.0223	22	n			CLI0101	50.20.2001			2 * TO 92-CLIP		R..0016	57.11.4682	6-8	k									
C..0028	59.06.0223	22	n			CLI0102	50.20.2001			2 * TO 92-CLIP		R..0017	57.11.4472	4-7	k									
C..0029	59.06.0223	22	n			CLI0201	50.20.2001			2 * TO 92-CLIP		R..0018	57.11.4102	1-0	k									
C..0030	59.06.0223	22	n								R..0019	57.11.4103	10	k										
C..0031	59.06.0223	22	n								R..0101	57.11.4101	100	k										
C..0032	59.06.0223	22	n								R..0102	57.11.4102	1-0	k										
C..0033	59.06.0223	22	n								R..0103	57.11.4101	100	k										
C..0034	59.06.0223	22	n								R..0104	57.11.4223	22	k										
C..0035	59.06.0223	22	n																					
C..0036	59.06.0223	22	n																					
C..0037	59.06.0223	22	n																					
C..0038	59.06.0223	22	n																					
C..0039	59.06.0223	22	n																					
C..0040	59.06.0223	22	n																					
C..0041	59.06.0223	22	n																					
C..0042	59.06.0223	22	n																					
C..0043	59.06.0223	22	n																					
C..0044	59.06.0223	22	n																					
C..0045	59.06.0223	22	n																					
C..0046	59.06.0223	22	n																					
C..0047	59.06.0223	22	n																					
C..0048	59.06.0223	22	n																					
C..0049	59.06.0223	22	n																					
C..0050	59.06.0223	22	n																					
C..0051	59.06.0223	22	n																					
C..0052	59.06.0223	22	n																					
C..0053	59.06.0223	22	n																					
C..0054	59.06.0223	22	n																					
C..0055	59.06.0223	22	n																					
C..0056	59.06.0223	22	n																					
C..0057	59.06.0223	22	n																					
C..0058	59.06.0223	22	n																					
C..0059	59.06.0223	22	n																					
C..0060	59.06.0223	22	n																					
C..0061	59.06.0223	22	n																					
C..0062	59.06.0223	22	n																					
C..0063	59.06.0223	22	n																					
C..0064	59.06.0223	22	n																					
C..0065	59.06.0223	22	n																					
C..0066	59.06.0223	22																						

OPERATING SECTION

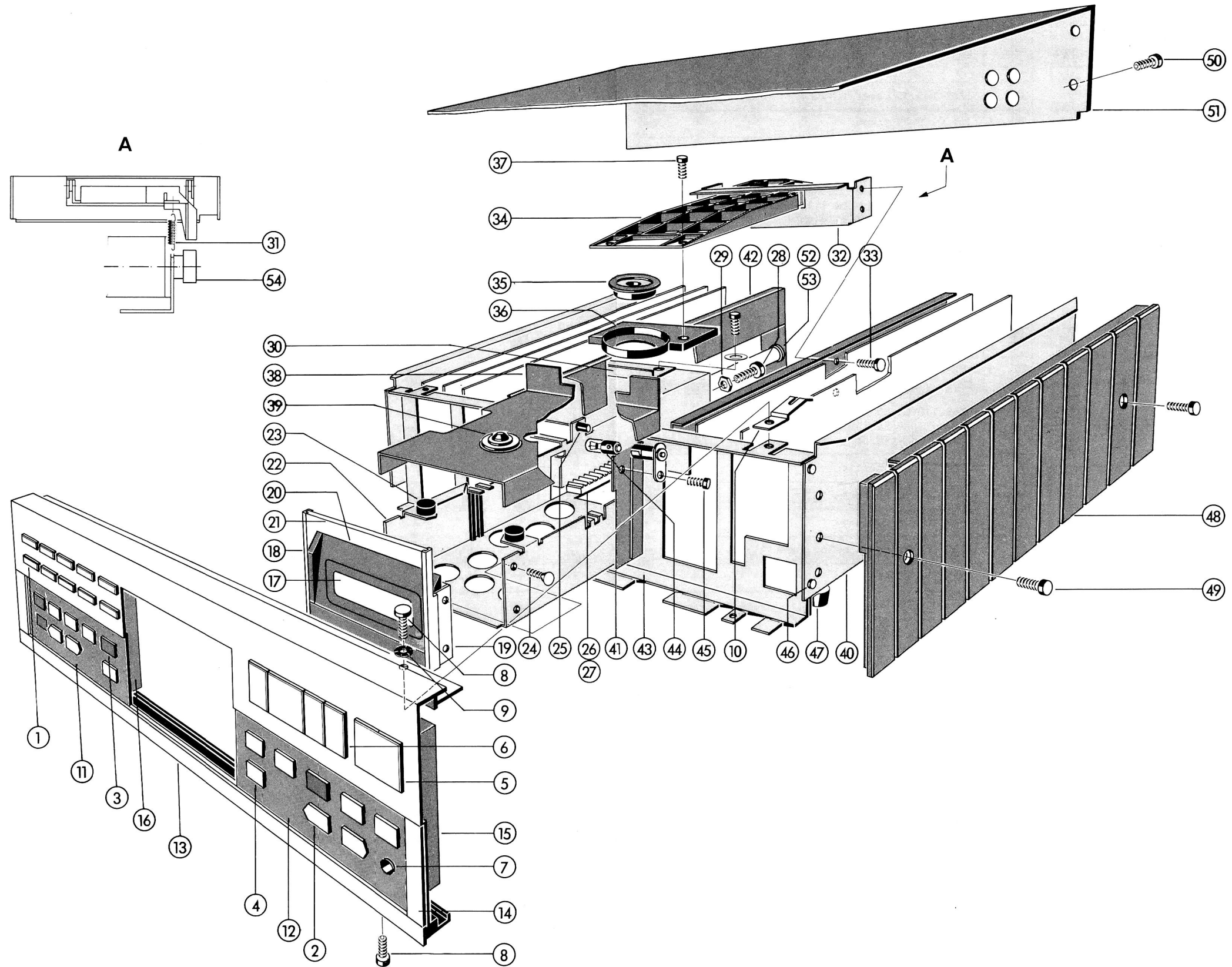

## OPERATING SECTION

	QTY	ORDER NUMBER	PART NAME	
01	10	1.769.100.10	Push button	5x21
02	4	1.769.100.22	Push button	arrow
03	3	1.769.100.01	Push button	red
04	9	1.769.100.21	Push button	grey
05	2	1.726.600.54	Push button	21x36
06	3	1.769.100.09	Push button	21x17,5
07	1	54.24.0101	Wire harness headphones	
	1	1.769.100.52	Clamping spring	
08	8	21.26.0353	Screw	M3x5
09	2	24.16.2030	Fan-shaped washer	
10	2	1.726.510.07	Flat spring	
11	1	1.769.100.08	Front shield	left
12	1	1.769.100.07	Front shield	right
13	1	1.769.104.00	Front cover	
14	2	1.769.100.23	Trim strip	
15	1	1.769.100.02	Operating chassis	right
	1	1.769.100.04	Conductive rubber mat	right
16	1	1.769.100.03	Operating chassis	left
	1	1.769.100.05	Conductive rubber mat	left
17	1	1.769.250.00	LCD - Board	
	3	20.21.7102	Screw	2.2x4.5
18	1	1.769.100.44	Holder	left
19	1	1.769.100.43	Holder	right
20	1	1.769.100.45	Cover	
21	1	1.769.100.46	Window	
22	1	1.769.100.41	Drawer	
23	4	1.769.110.02	Damping element	
24	4	1.010.031.21	Screw	M5x3
25	1	1.769.100.51	Bolt	
	2	23.01.3043	Washer	4.3
	1	24.16.1040	Lock washer	4.3
	1	22.01.8040	Nut	M4
26	1	1.769.100.47	Toothed rack	
27	3	20.23.7371	Screw	self-tapping
28	1	21.99.0172	Screw	M3x10
29	1	22.01.5030	Nut	M3
30	1	1.769.100.61	Sensor shield	
	2	21.26.0353	Screw	M3
	2	23.01.3032	Washer	3.2

	QTY	ORDER NUMBER	PART NAME	
31	1	1.010.100.37	Tension spring	
	1	1.010.037.37	Serial numbers from 9524 up to 10235 and from 11188 onward.	
	1	1.010.037.37	Tension spring	
	1	1.010.037.37	Serial numbers up to 9523 and from 10236 up to 11187.	
32	1	1.769.100.26	Level support	
33	4	21.99.0173	Screw	M3x4
34	1	1.769.100.54	Solenoid lift	
35	1	1.769.112.03	Adhesive magnet	
	1	1.769.110.03	Serial numbers from 9524 up to 10235 and from 11188 onward.	
	1	1.769.110.03	Adhesive magnet	
	1	1.769.110.03	Serial numbers up to 9523 and from 10236 up to 11187.	
36	1	1.769.100.37	Solenoid holder	
37	2	20.23.7355	Screw	self-tapping
38	1	1.769.100.34	CD - Drive Cover	
	2	20.99.0102	Screw	2.9 spec.
39	1	1.769.112.00	CD - Drive	
	1	1.769.110.00	Serial numbers from 9524 up to 10235 and from 11188 onward.	
	1	1.769.110.00	CD - Drive	
	1	1.769.110.00	Serial numbers up to 9523 and from 10236 up to 11187.	
40	1	1.769.102.01	Chassis	
41	1	1.769.100.27	Support	right
42	1	1.769.100.28	Support	left
43	1	1.769.100.24	Basic print support	
44	2	51.02.0127	Bulb	15 V
45	2	21.99.0173	Screw	M3x4
46	8	21.26.0353	Screw	M3x5
47	4	31.02.0209	Foot	
48	1	1.769.090.06	Side cover	right/left
49	4	1.010.027.21	Screw	M4x12
50	5	1.010.026.21	Screw	M3x5
51	1	1.769.090.02	Cover plate	
52	1	1.769.100.30	Guiding rod	long
	2	1.769.100.32	Bearing bushing	
	2	24.16.5120	Retaining ring	
	2	24.16.3060	Retaining clip	
53	1	1.769.100.31	Guiding rod	short
	1	1.769.100.32	Bearing bushing	
	1	24.16.5120	Retaining ring	
	2	24.16.3060	Retaining clip	
54	1	1.769.100.48	Toothed wheel	
	1	21.59.5452	Hexagon socket set screw	

CD DRIVE SERIAL NUMBERS UP TO 9523 AND FROM 10236 UP TO 11187

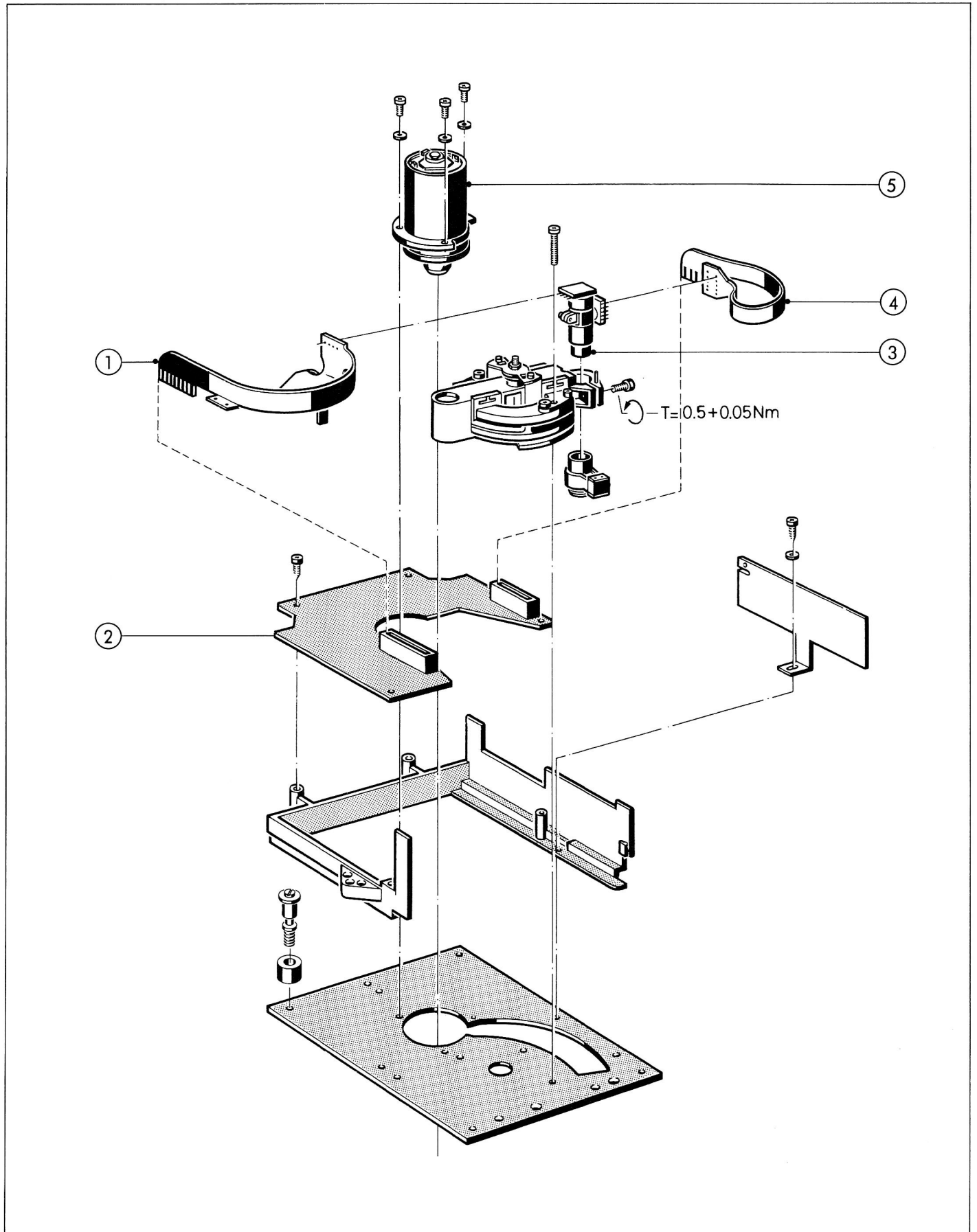

## CD DRIVE SERIAL NUMBERS UP TO 9523 AND FROM 10236 UP TO 11187.

	QTY	ORDER NUMBER	PART NAME
01	1	1.769.110.25	Flex. print 1
02	1	1.769.110.30	CD - drive print
03	1	1.769.110.27	Laser
04	1	1.769.110.26	Flex. print 2
05	1	1.769.110.24	CD - motor



CD DRIVE SERIAL NUMBERS FROM 9524 UP TO 10235 AND FROM 11188 ONWARD.

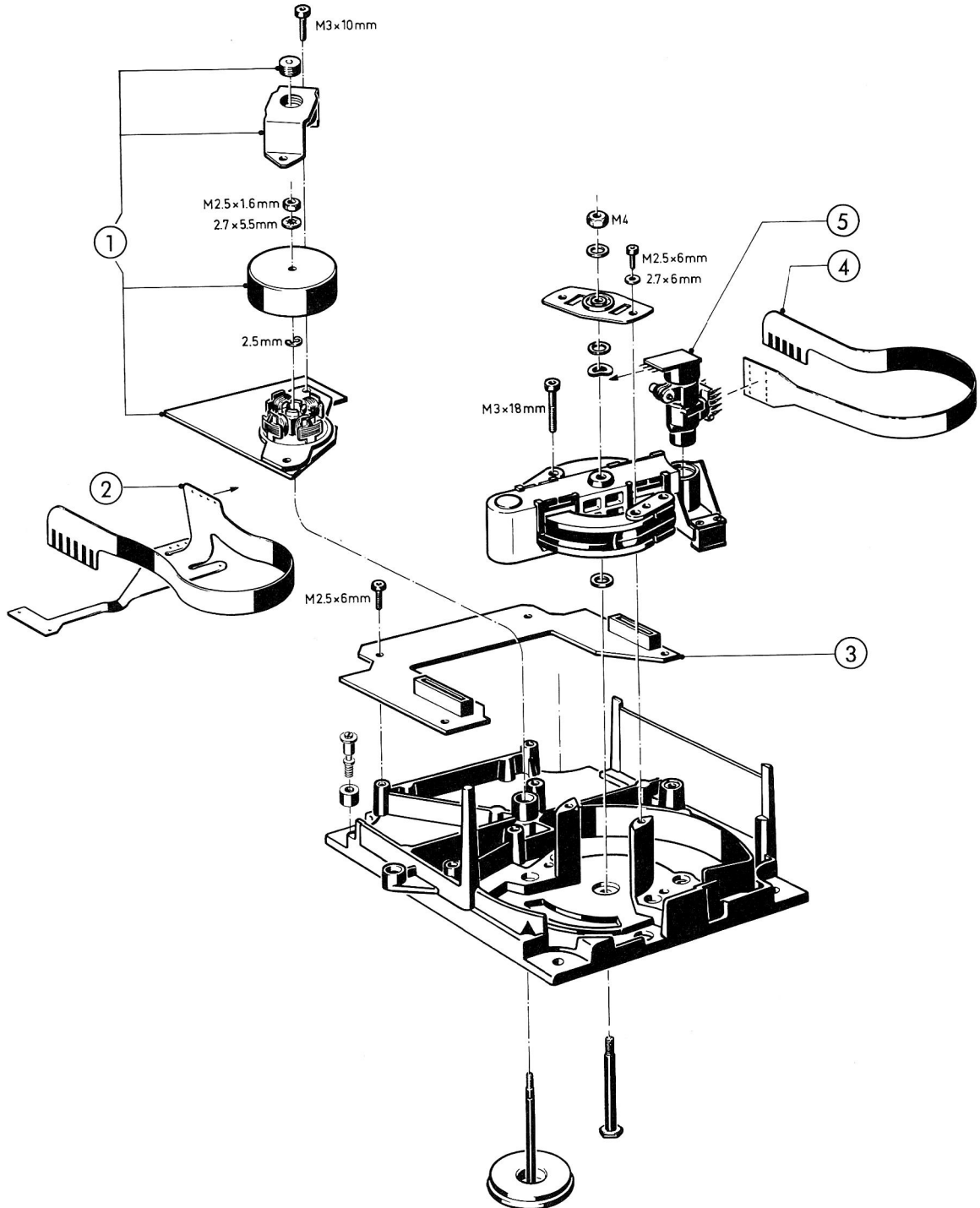

## CD DRIVE SERIAL NUMBERS FROM 9524 UP TO 10235 AND FROM 11188 ONWARD

	QTY	ORDER NUMBER	PART NAME
01	1	1.769.112.33	Casting chassis
02	1	1.769.112.30	CD- drive print
03	1	1.769.112.28	Laser support
04	1	1.769.110.29	Focussing unit
05	1	1.769.110.26	Flex. print 2
06	1	1.769.110.25	Flex. print 1
07	1	1.769.110.27	Laser
08	1	1.769.112.24	CD- drive motor
09	4	1.769.110.01	Spec. screw

**7. TECHNISCHER ANHANG****7.1 Technische Daten****A Audio- Daten**

Anzahl Kanäle: 2  
 Frequenzgang: 20Hz ... 20kHz, +0/-0,6dB  
 Klirrfaktor: < 0,006% (20Hz ... 20kHz)  
 Fremdspannungsabstand: > 96dB (20Hz ... 20kHz)  
 Geräuschspannungsabstand: > 100dB (20Hz ... 20kHz)  
 Uebersprechen: > 90dB (20Hz ... 20kHz)  
 Ausgangspegel:  
 - AUDIO OUTPUT FIXED 2V, Ri <500 Ohm, kurzschlussfest  
 - AUDIO OUTPUT VARIABLE 0 ... 2V, Ri <500 Ohm, kurzschlussfest  
 Kopfhörer- Ausgang 4,5V, Ri <50 Ohm, kurzschlussfest  
 Kanalgleichheit (L/R) <0,2dB  
 Phasenlinearität durch digitale Filterung (Oversampling)  
 Monokompatibilität durch getrennte D/A-Wandler L und R

**B Abtast- System**

Abtastfrequenz: 44,1 kHz  
 Quantisierung: 16 Bit linear/Kanal  
 optischer Abtaster: AlGaAs- Halbleiterlaser  
 Wellenlänge: 0,78 µm  
 Fehlerkorrektur- System: CIRC (Cross Interleave Reed Solomon Code)  
 Preemphasis 50/15µs, wird automatisch durch Subcode der CD geschaltet

**C Laufwerk / Steuerung**

CD- Drehgeschwindigkeit: 500 ... 200 U/min  
 Abtastgeschwindigkeit: 1,2 ... 1,4 m/s  
 Gleichlaufschwankungen: quärzgenau  
 max. Spieldauer: 74 Minuten  
 Startzeit aus Pause: < 0,6s  
 Suchzeit fuer beliebige Stelle: < 4s (ueber 12000 Spuren pro Sekunde)

**D Anzeige**

Multifunktionaler LC-Display informiert ueber folgende Zustaende:  
 TRACK: der aktuelle Stand kann entweder in der TRACK- Anzeige oder im 30- Segment-Balken gelesen werden.  
 INDEX: Indices werden automatisch angezeigt  
 TIME: jede moegliche Zeit kann ausgelesen werden; TRACK TIME und CD TIME.  
 PAUSE, AUTOSTOP, LOOP: spezielle Betriebsarten werden ausgelesen.  
 PROGRAM MODE: jeder Programm- Schritt wird sekunden-genau angezeigt.

**E Programmiermoeglichkeiten**

Anzahl Programm- Schritte: 19  
 Inhalt der Programm- Schritte: TRACK, TIME oder auch vermischt  
 Programmiermoeglichkeiten: Eingabe ueber Keyboard oder durch Setzen von Marken.  
 Genauigkeit der Schritte: jeder Schritt kann sekundengenau definiert werden.  
 Sonderfunktionen: Sonderfunktionen wie LOOP, PAUSE etc. koennen programmiert werden.

**F Allgemeines**

Stromversorgung: 100/120/140V, 200/220/240V +/-10%  
 einstellbar, 50/60 Hz  
 Netzsicherungen: 100 ... 140V = T 500 mA slow  
 200 ... 240V = T 250 mA slow  
 Stromverbrauch: max. 40 Watt  
 Abmessungen: 450 x 109 x 332 mm (BxHxT)  
 Gewicht (Masse): 8,5kg

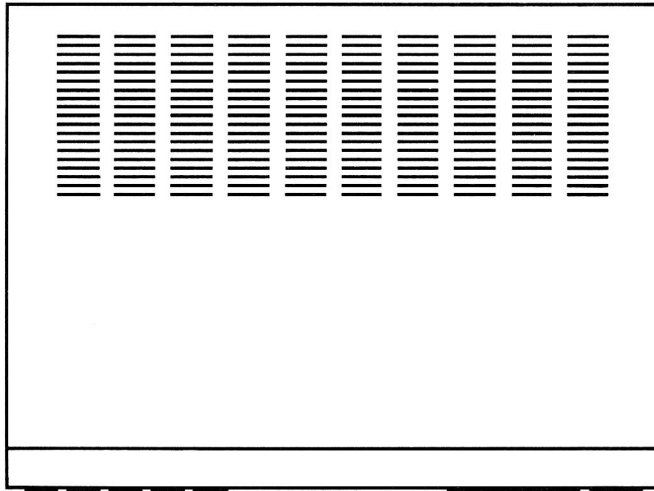
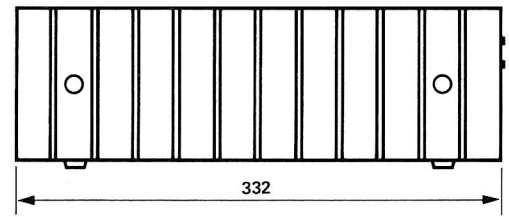
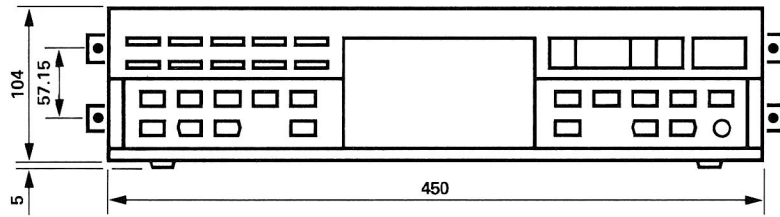
**7.2** Abmessungen (mm)

7. TECHNICAL APPENDIX7.1 Technical data

## A Audio data

Number of channels: 2  
Frequency response: 20 Hz to 20 kHz, +0/-0.6 dB  
Harmonic distortion: < 0.006% (20 Hz to 20 kHz)  
S/N ratio, linear: > 96 dB (20 Hz to 20 kHz)  
S/N ratio, weighted: > 100 dB (20 Hz to 20 kHz)  
Cross talk attenuation: > 90 dB (20 Hz to 20 kHz)  
Output level:  
- AUDIO OUTPUT FIXED 2 V,  $R_i < 500$  ohms,  
short-circuit proof  
- AUDIO OUTPUT VARIABLE 0 to 2 V,  $R_i < 500$  ohms,  
short-circuit proof  
Headphones output: 4.5 V,  $R_i < 50$  ohms,  
short-circuit proof  
Channel balance (L/R): < 0.2 dB  
Phase linearity through digital filter (oversampling)  
Mono compatibility through separated D/A converters L and R

## B Scanning system

Sampling frequency: 44.1 kHz  
Quantizing: 16 bit linear/channel  
Optical readout system: AlGaAs semiconductor laser  
Wave length: 0.78  $\mu$ m  
Error correction system: CIRC (Cross Interleave  
Reed Solomon Code)  
Preemphasis: 50/15  $\mu$ s, automatically controlled  
by subcode of CD

## C Player mechanism / control

Rotary speed of CD: 500 to 200 r.p.m.  
Scanning velocity: 1.2 to 1.4 m/s  
Wow and flutter: quartz accuracy  
Max. playing time: 74 minutes  
Start delay from pause: < 0.6 s  
Search time for  
any location: < 4 s (over 12,000 tracks per second)

## D Display

Multifunction LC display, supplies the following status information:  
TRACK: The current track can either be read  
off the TRACK display or the 30-segment  
bar.  
INDEX: Indices are displayed automatically  
TIME: Any time can be read out; TRACK TIME  
and CD TIME  
PAUSE, AUTOSTOP, LOOP: Special operation modes are read out.  
PROGRAM MODE: Each program step is displayed with  
seconds accuracy.

## E Programming facilities

Number of program steps: 19  
Contents of program steps: TRACK, TIME or mixed  
Programming facilities: Input via keyboard or by setting marks.  
Accuracy of steps: Each step can be defined with seconds  
accuracy.  
Special functions: Special functions such as LOOP, PAUSE,  
etc. can be programmed.

## F General

Power requirements: 100/120/140 V, 200/220/240 V  $\pm 10\%$   
adjustable, 50/60 Hz  
Power fuses: 100 to 140 V = 500 mA slow-blow  
200 to 240 V = 250 mA slow-blow  
Power consumption: Max. 40 W  
Dimensions: 450 x 109 x 332 (W x H x D)  
Weight: 8.5 kg

7.2 Dimensions (mm)

