

# TECHNICAL MANUAL

*Quality Uncompromised*

# ROTEL® RA-840BX4

STEREO INTEGRATED AMPLIFIER

## TABLE OF CONTENTS

Chassis Layout .....	1
Adjustment .....	1
Schematic Diagram.....	2
Wiring Diagram.....	4
Printed Circuit Boards.....	5
PC Board Ass'y Parts List .....	6

**THE ROTEL CO., LTD.**

1-36-8 OHOKAYAMA, MEGURO-KU, TOKYO 152, JAPAN

**ROTEL ELECTRONICS CO., LTD.**

ROTEL BLDG., 3F. NO. 35, FUSING N. ROAD, TAIPEI, TAIWAN, REPUBLIC OF CHINA

MN20001755

# Chassis Layout

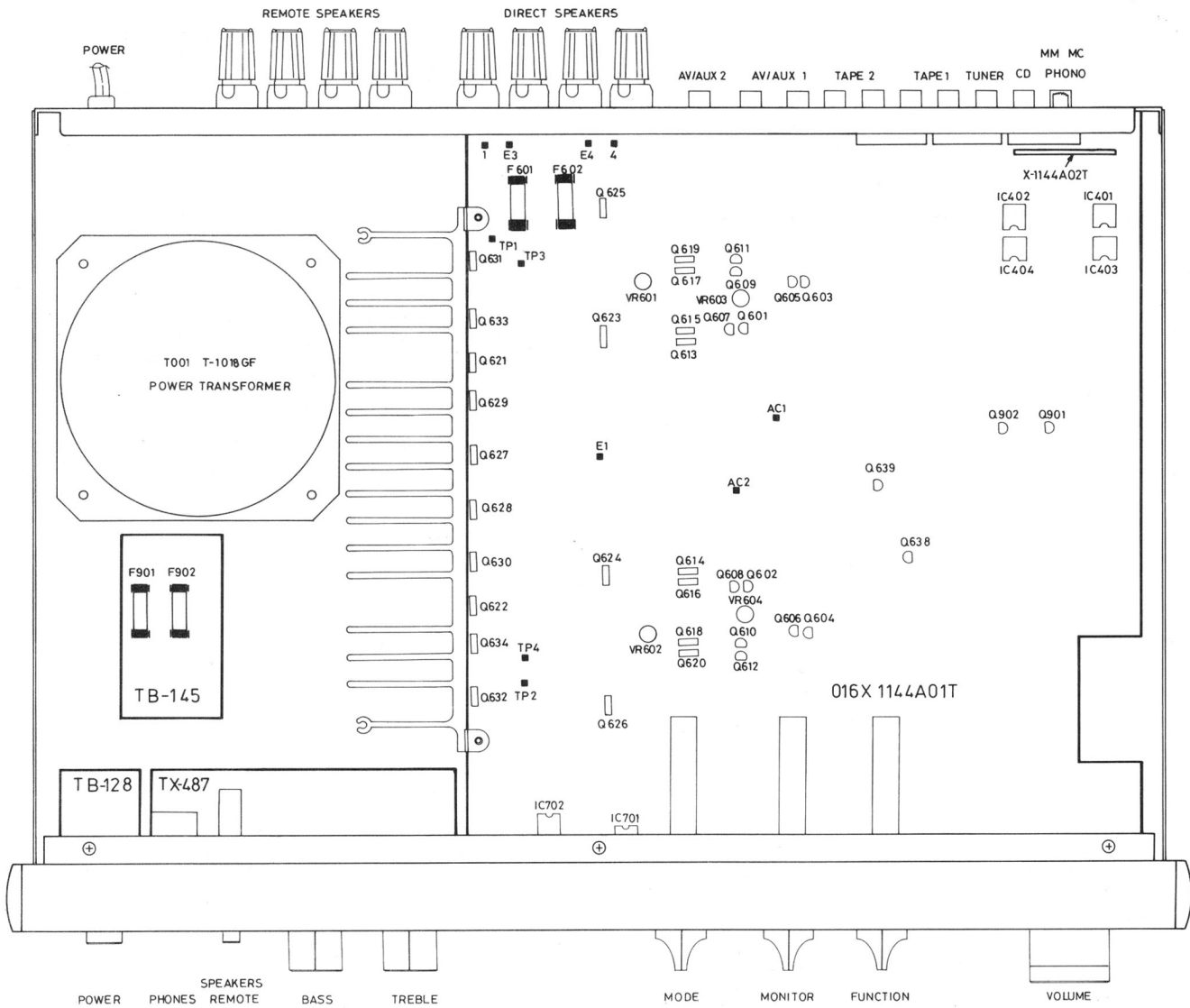

## Power Amplifier Bias Adjustment

**Instruments:** DC milli-voltmeter

**Notes:** Prior to Bias Adjustment, run about 5 minutes with rated output (8 ohm) and warm up Power Transistor and Heat Sink.  
Set Volume Control to Minimum.

Step	Coupling		Adjust	Adjust for
	Plus Lead	Minus Lead		
1	TP3	TP1	VR601	DC milli-voltmeter reads 2.5mV
2	TP4	TP2	VR602	
3	1	E1	VR603	DC milli-voltmeter reads 0 mV
4	2	E2	VR604	

# Schematic Diagram

NOTE: PARTS AND CIRCUIT SUBJECT TO CHANGES FOR IMPROVEMENT WITHOUT PRIOR NOTICE.

## RA-840BX4

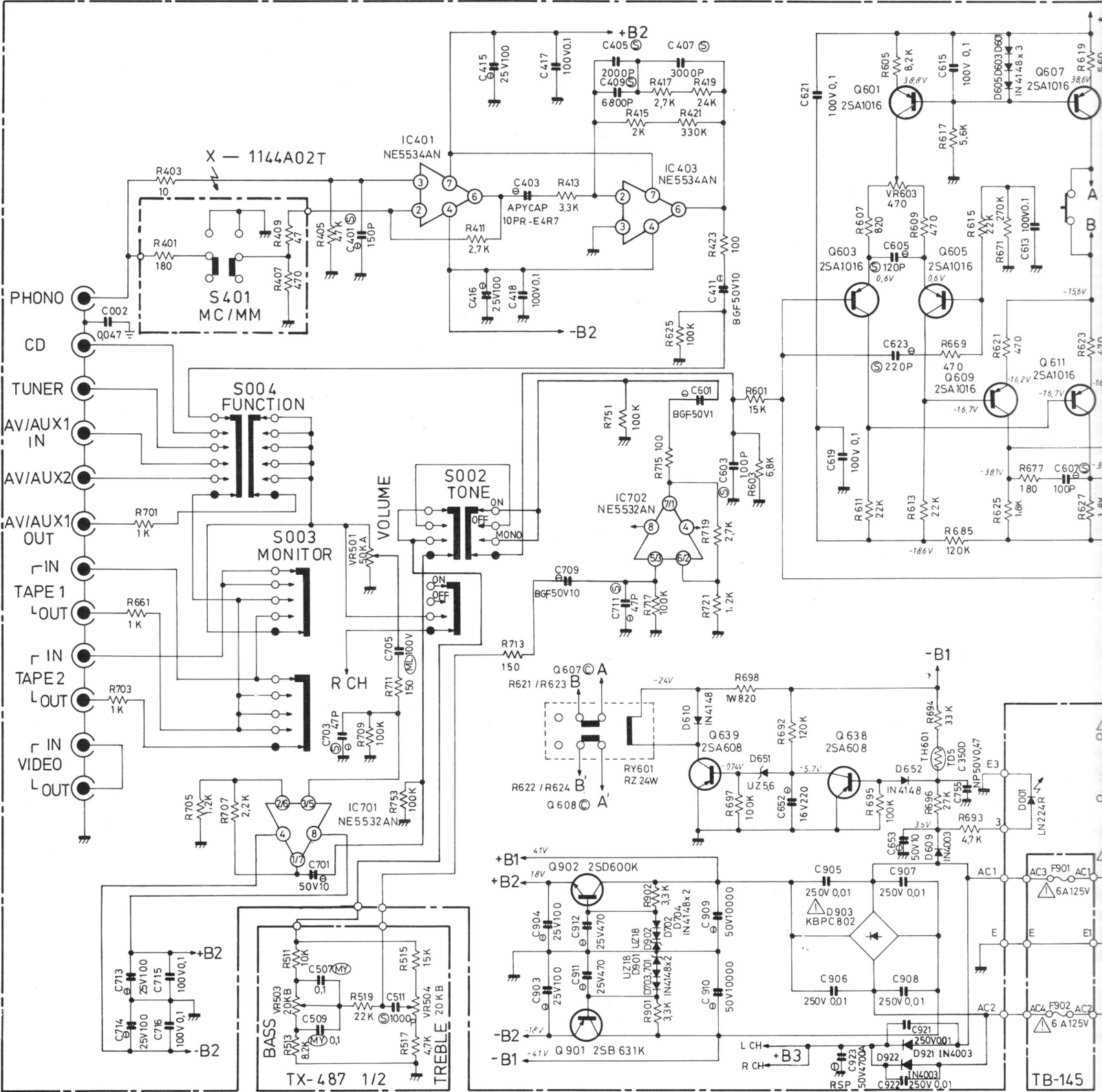

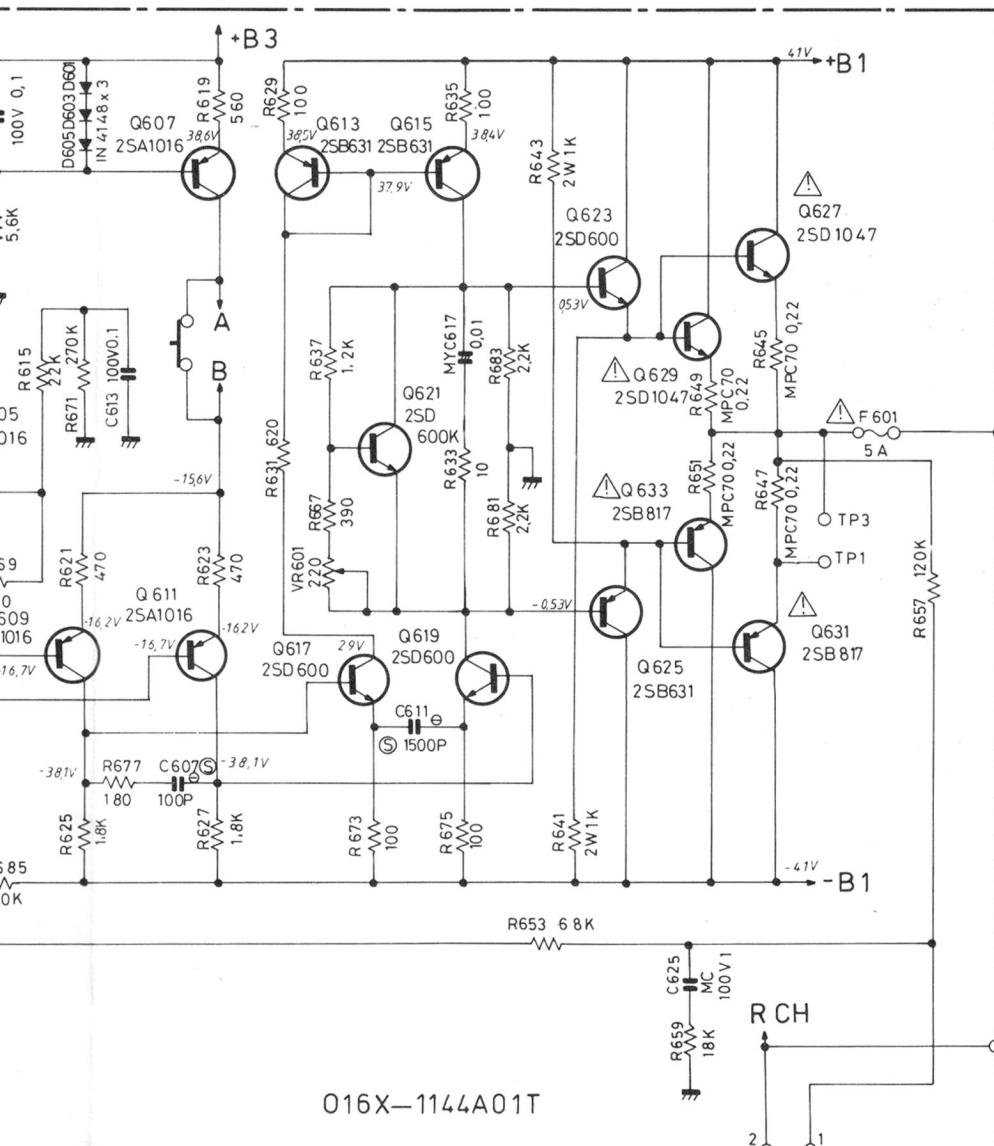

016X-1144A01T

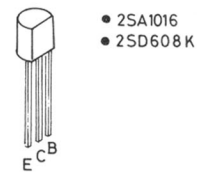

- 2SA1016
- 2SD608K

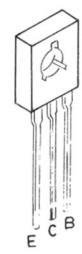

- 2SD600K
- 2SB631



- 2SB817
- 2SD1047

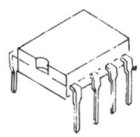

- NE5532AN
- NE5534AN

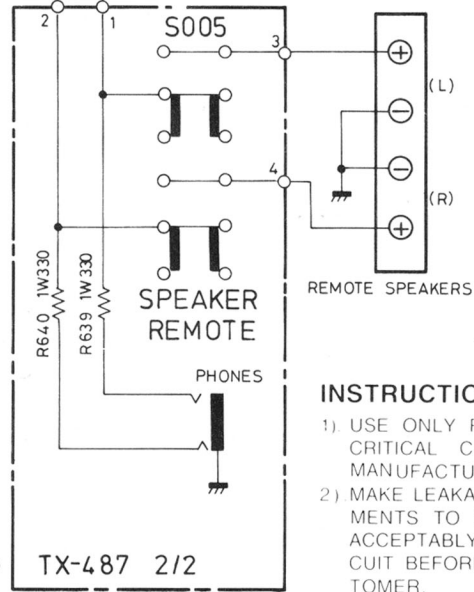
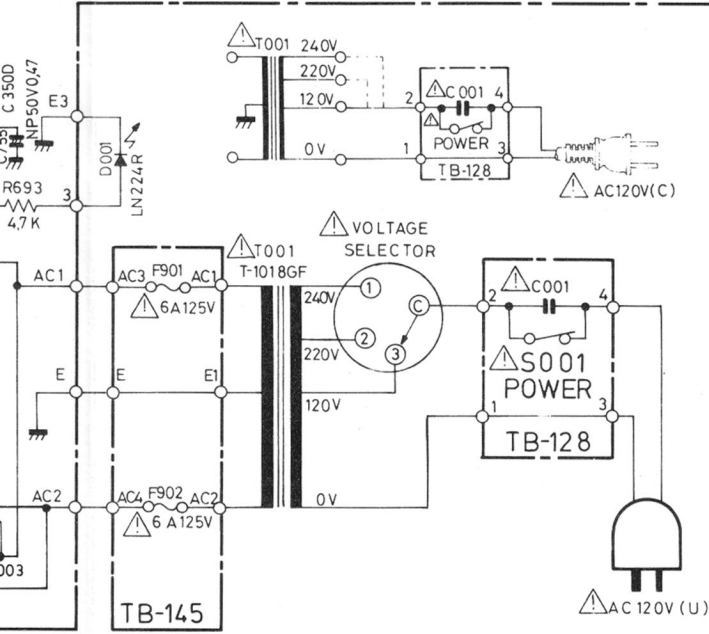

**INSTRUCTIONS FOR SERVICING PERSONNEL:**

- 1) USE ONLY REPLACEMENT PARTS THAT HAVE THE CRITICAL CHARACTERISTICS RECOMMENDED BY MANUFACTURER.
- 2) MAKE LEAKAGE-CURRENT OR RESISTANCE MEASUREMENTS TO DETERMINE THAT EXPOSED PARTS ARE ACCEPTABLY INSULATED FROM THE AC SUPPLY CIRCUIT BEFORE RETURNING THE UNIT TO THE CUSTOMER.

# Wiring Diagram

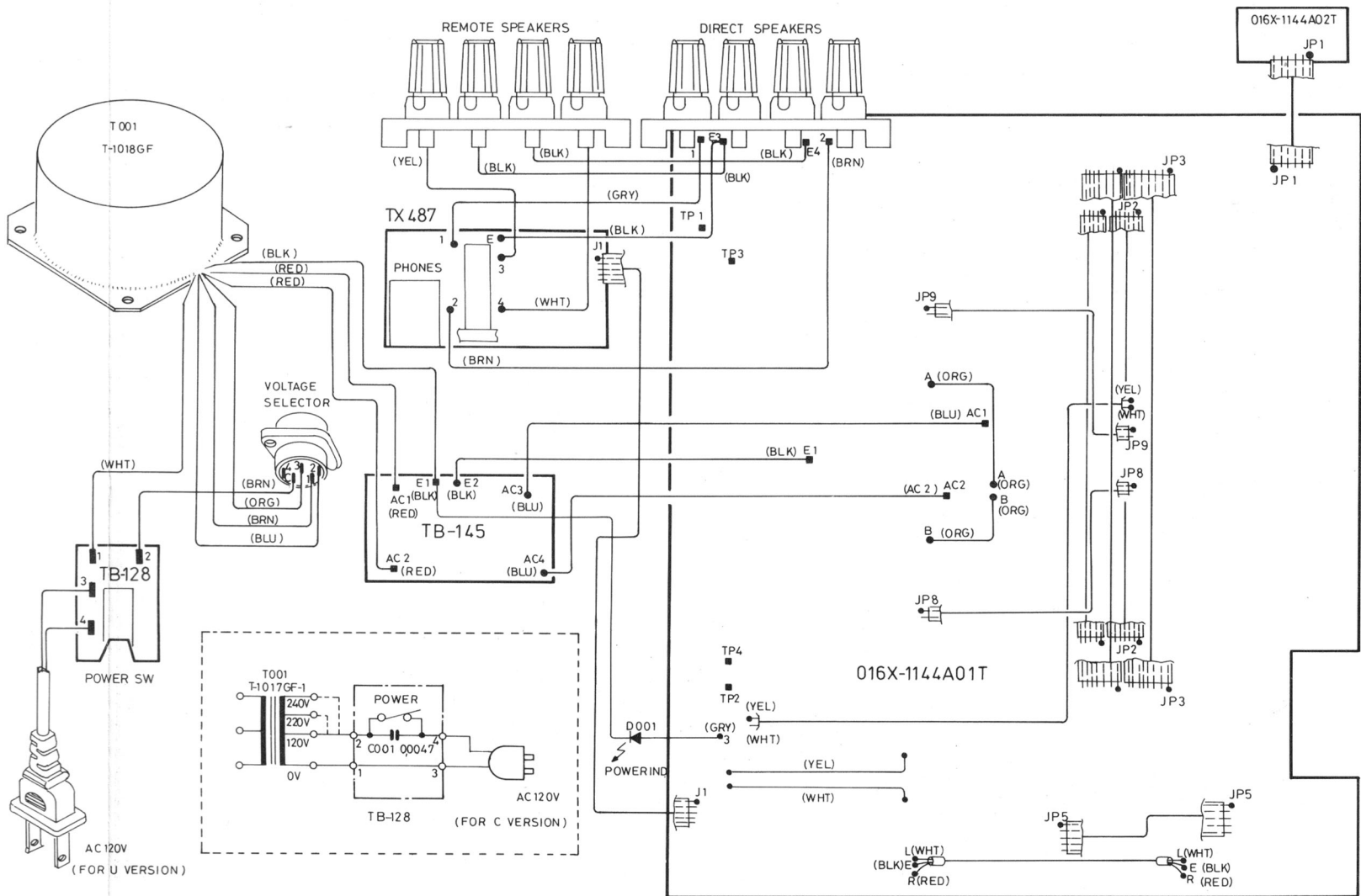

# Printed Circuit Boards

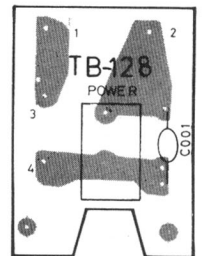
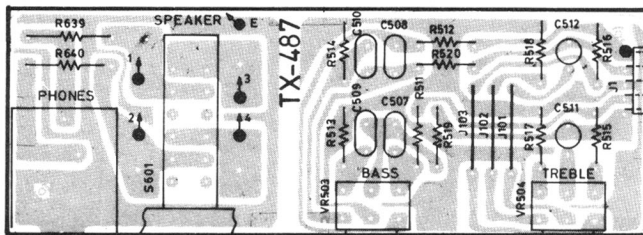
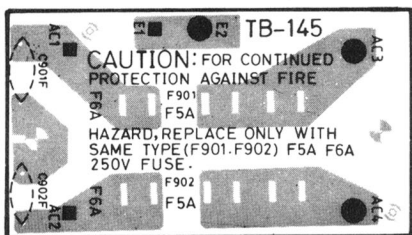
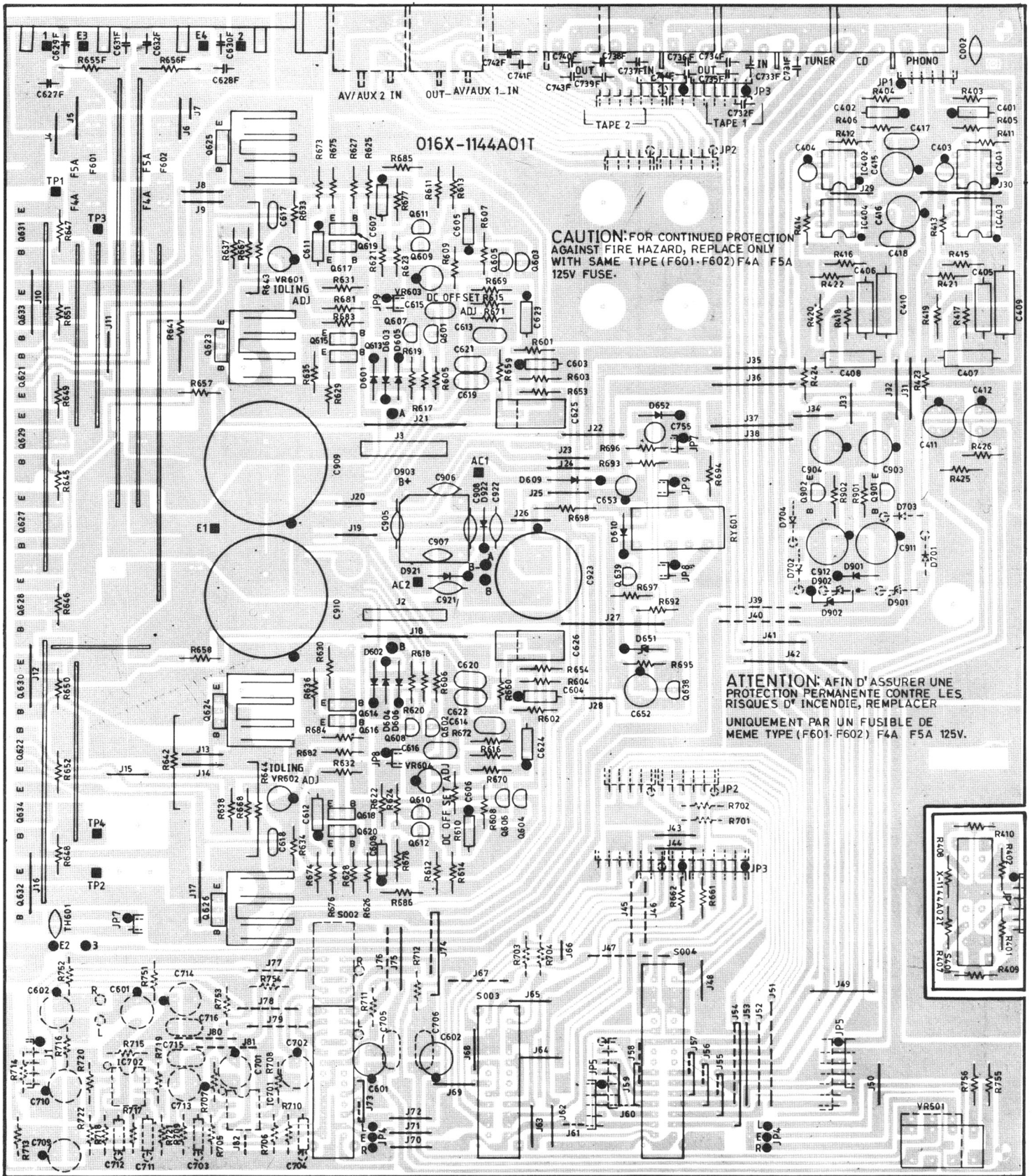

# Parts List

NOTE: THE COMPONENTS IDENTIFIED BY  $\Delta$  MARK ARE FOR SAFETY. REPLACE ONLY WITH ORIGINAL PARTS. DO NOT SUBSTITUTE.

SYMBOL	PARTS NO.	DESCRIPTION
X-1144A01T PCB ASSEMBLY		
R403,404	RM11009715	R,METAL MRS2510R 0.4W
R405,406	RM14702715	R,METAL MRS2547K 0.4W
R411,412	RM12701718	R,METAL MRS252.7K 0.4W
R413,414	RM13301710	R,METAL MRS253.3K 0.4W
R415,416	RM12001710	R,METAL MRS252K 0.4W
R417,418	RM12701718	R,METAL MRS252.7K 0.4W
R419,420	RM12402715	R,METAL MRS2524K 0.4W
R421,422	RM13303717	R,METAL MRS25330K 0.4W
R423,424	RM11000712	R,METAL MRS25 100R 0.4W
R425,426	RM11003713	R,METAL MS25100K 0.4W
C401,402	CS31511318	CAP,STYROL 150P 50V
C403,404	CA14707830	CAP,APYCAP 4.7uF 10V
C405,406	CS32010301	CAP,POLYSTYRENE 2000P 160V
C407,408	CS33010308	CAP,POLYSTYRENE 3000P 160V
C409,410	CS36810300	CAP,POLYSTYRENE 6800P 160V
C411,412	CE01006500	CAP,ELEC. 10uF 50V
C415,416	CE51005254	CAP,ELEC. 100uF 25V
C417,418	CP61008321	CAP,M.P. 0.1uF 100V
IC401-404	IC00001735	IC NE5534AN
VR501	RV10001498	R,VARIABLE 4TR-2691
R601,602	RM01502714	R,METAL MRS2515K 0.4W
R603,604	RM16801710	R,METAL MRS256.8K 0.4W
R605,606	RM18201710	R,METAL MRS258.2K 0.4W
R607,608	RM18200716	R,METAL MRS25820R 0.4W
R609,610	RM14700718	R,METAL MRS25470R 0.4W
R611-616	RM12202714	R,METAL MRS2522K 0.4W
R617,618	RM15601712	R,METAL MRS255.6K 0.4W
R619,620	RM15600719	R,METAL MRS25560R 0.4W
R621-624	RM14700718	R,METAL MRS25470R 0.4W
R625-628	RM11801710	R,METAL MRS251.8K 0.4W
R629,630	RM11000712	R,METAL MRS25100R 0.4W
R631,632	RM15600719	R,METAL MRS25560R 0.4W
R633,634	RM11009715	R,METAL MRS2510R 0.4W
R635,636	RM11000712	R,METAL MRS25100R 0.4W
R637,638	RM11201717	R,METAL MRS251.2K 0.4W
R641-644	RM61001229	R,METAL RD2BJ1K
R645-652	RS20228230	R,SQUARE TYPE MPC70-0.22F
R653,654	RM16802713	R,METAL MRS2568K 0.4W
R657,658	RM11203714	R,METAL MRS25120K 0.4W
R659,660	RM01802710	R,METAL MRS2518K 0.4W
R661,662	RM11001716	R,METAL MRS251K 0.4W
R667,668	RM13900719	R,METAL MRS25390R 0.4W
R669,670	RM14700718	R,METAL MRS25470R 0.4W
R671,672	RM12703715	R,METAL MRS25270K 0.4W
R673,674	RM11000712	R,METAL MRS25100R 0.4W
R675,676	RM11000712	R,METAL MRS25100R 0.4W
R677,678	RM01800713	R,METAL MRS25180R 0.4W
R681-684	RM02201718	R,METAL MRS252.2K 0.4W
R685,686	RM11203714	R,METAL MRS25120K 0.4W
R692	RD21203820	R,CARBON 120K J 1/4W
R693	RD24701829	R,CARBON 4.7K J 1/4W
R694	RD23002828	R,CARBON 30K J 1/4W
R695	RD21003829	R,CARBON 100K J 1/4W
R696	RD22702820	R,CARBON 27K J 1/4W
R697	RD21003829	R,CARBON 100K J 1/4W
R698	RM98200120	R,METAL 820 1W

SYMBOL	PARTS NO.	DESCRIPTION
C601,602	CE54707478	CAP,ELEC. 4.7uF 50V
C603,604	CS31011310	CAP,POLYSTYRENE 100P 160V
C605,606	CS31211300	CAP,POLYSTYRENE 120P 160V
C607,608	CS31011310	CAP,POLYSTYRENE 100P 160V
C611,612	CS31510302	CAP,POLYSTYRENE 1500P 160V
C613-616	CP61008321	CAP,M.P. 0.1uF 100V
C617,618	CM01009427	CAP,MYLAR 103 J 50V
C619-622	CP61008321	CAP,M.P. 0.1uF 100V
C623,624	CS32211306	CAP,POLYSTYRENE 220P 160V
C625,626	CY01007303	CAP,LAYER 1uF 100V
C652	CE02205164	CAP,ELEC. 220uF 16V
C653	CE01006500	CAP,ELEC. 10uF 50V
Q601-610	TR10000023	TRANSISTOR 2SA1016
Q613-616	TR10000047	TRANSISTOR 2SB631K
Q617-624	TR40000069	TRANSISTOR 2SD600K
Q625,626	TR10000047	TRANSISTOR 2SB631K
Q627-630	TR40000045	TRANSISTOR 2SD1047
Q631-634	TR20000040	TRANSISTOR 2SB817
Q638,639	TR10000126	TRANSISTOR 2SA608K
D601-610	DD10000100	DIODE 1N4148
D651	DD20000041	DIODE RD-5.6E
D652	DD10000100	DIODE 1N4148
VR601,602	RV40000046	R,SEMI-FIXED VM6CKPV-1S-B 220 OHM
VR603,604	RV40000058	R,SEMI-FIXED VM6CKPV-1S-B 470 OHM
RY601	LY00000174	RELAY RZ-24W
TH601	DD60000260	THERMINTOR TD5C350C $\Delta$
C002	CC05009457	CAP,CERAMIC 0.047uF 50V
R701-704	RM11001716	R,METAL MRS251K 0.4W
R705,706	RM11201717	R,METAL MRS251.2K 0.4W
R707,708	RM02201718	R,METAL MRS252.2K 0.4W
R709,710	RM21003829	R,METAL MRS25100K 0.4W
R711-714	RM11500710	R,METAL MRS25150R 0.4W
R715,716	RM11000712	R,METAL MRS25100R 0.4W
R717,718	RM11003713	R,METAL MRS25100K 0.4W
R719,720	RM12701718	R,METAL MRS252.7K 0.4W
R721,722	RM11201717	R,METAL MRS251.2K 0.4W
R751-754	RM11003713	R,METAL MRS25100K 0.4W
R755,756	RM15601712	R,METAL MRS255.6K 0.4W
C701,702	CE01006500	CAP,ELEC. 10uF 50V
C703,704	CS34712311	CAP,POLYSTYRENE 47P 160V
C709,710	CE01006500	CAP,ELEC. 10uF 50V
C711,712	CS34712311	CAP,POLYSTYRENE 47P 160V
C713,714	CE51005254	CAP,ELEC. 100uF 25V
C715,716	CP61008321	CAP,M.P. 0.1uF 100V
C755	CN04708503	CAP,NON-POLARIZED 0.47uF 50V NP
D701-704	DD10000100	DIODE 1N4148
IC701,702	IC00001693	IC NE5532AN
S002	SH30000420	FUNCTION SW 4TR-2401
S003	SH30000407	FUNCTION SW 4TR-2399
S004	SH30000419	FUNCTION SW 4TR-2400
R901,902	RM13301710	R,METAL MRS253.3K 0.4W
C903,904	CE51005254	CAP,ELEC. 100uF 25V
C905-908	CC01009256	CAP,CERAMIC 0.01uF 250V $\Delta$
C909,910	CE51003403	CAP,ELEC. 10000uF 50V $\Delta$
C911,912	CE64705259	CAP,ELEC. 470uF 25V

SYMBOL	PARTS NO.	DESCRIPTION
C921,922	CC01009256	CAP,CERAMIC 0.01uF 250V $\Delta$
C923	CE54704477	CAP,CERAMIC 4700uF 50V $\Delta$
Q901	TR10000047	TRANSISTOR 2SB631K
Q902	TR40000069	TRANSISTOR 2SD600K
D901,902	DD20000041	DIODE RD18E
D903	DD10000147	DIODE KBPC802 $\Delta$
D921,922	DD10000068	DIODE 1N4003
X-1144A02T PCB ASSEMBLY		
R401,402	RM01800713	R,METAL MRS25180R 0.4W
R407,408	RM14700718	R,METAL MRS25470R 0.4W
R409,410	RM14709710	R,METAL MRS2547R 0.4W
S401	SH20000265	SLIDE SW 4TR-2172
TX-487 PCB ASSEMBLY		
R511,512	RM11002710	R,METAL MRS2510K 0.4W
R513,514	RM18201710	R,METAL MRS258.2K 0.4W
R515,516	RM01502714	R,METAL MRS2515K 0.4W
R517,518	RM14701711	R,METAL MRS254.7K 0.4W
R519,520	RM12202714	R,METAL MRS2522K 0.4W
C507-510	CM01008423	CAP,MYLAR 104 J 50V
C511,512	CS41010429	CAP,STYROL 1000P 50V
VR503,504	RV10000433	R,VARIABLE 4TR-1742
S601	SH11000239	1 KEY PUSH SW 4TR-2328
R639,640	RM93300123	R,METAL 330 1W
	JH00000135	HEAD PHONE JACK C-3399#1
TB-145 PCB ASSEMBLY		
F901,902	FU24000136	FUSE 125V UL/CSA 5MF 6.0A (U,C,A) $\Delta$
	FU23000086	FUSE 250V 6.3A $\Delta$
TB-128A PCB ASSEMBLY		
S001	SH40000120	POWER SW C-3600B-T $\Delta$
C001	CK00000035	SPARK KILLER DE7150F472M $\Delta$
OTHERS		
	AB00000470	BOTTOM BOARD 3TTH-10C#3
	AF20000210	FRONT CHASSIS 2TTH-2A#2
	AM00001458	CHASSIS BODY 3TTH-6A
	AR20000486	PRINTED REAR CHASSIS
	AS01000221	SIDE CHASSIS 3TTH-8A
	PT00000229	POWER TRANSFORMER T-1018GF $\Delta$
	FT00000138	RUBBER FOOT 4TR-2274 40F $\times$ 8
	CD00000218	AC CORD SPT-2 AWG#18 4TR-670#4 (U,C,A,H1-H4) $\Delta$
	CD00000048	AC POWER CORD 4TR-1037 (H5-H7,E,K2) $\Delta$
	CD00000085	AC POWER CORD C-2504A (K1) $\Delta$
	CD00000115	AC POWER CORD C-3763-T (G) $\Delta$

SYMBOL	PARTS NO.	DESCRIPTION
	VC00000048	VOLTAGE SELECTOR FS907B (U) $\Delta$
	AH20000485	HEAT SINKER BOARD 4TTH-12#2
	KB10001321	KNOB 4TR-2255 20F
	KB10001424	KNOB 4TR-2356#2 20F M
	KB10001436	KNOB 4TR-2366 33F WF
	KB10001448	KNOB 4TR-2367 33F
	KB20000507	PUSH BUTTON C-3982#2-T
	KB20001561	PUSH BUTTON 4TR-2176 14x14
	AU00001067	UPPER COVER 3TTF-5#5
	PL00000770	STYROL SIDE MOULDING 2TTF-9A TZ-165
	SR00000316	FIBER SPACER 4TZX-27A#2
	SR00000882	UPPER COVER SPACER 4TR-2418
	SR00000936	KNOB SPACER 4TR-2541 29.5F
	TN10003288	INSIDE CARTON 4TR-2377#10
	AA20000567	FRONT PANEL 2TT-1B#6
	BU00000384	PUSH RING 4TR-1546#2
	OM10000085	ORNAMENTAL SIDE PLATE 3TTF-6
	BU00000682	POWER BUTTON RING 4TR-2177 14x14