

# **ROTEL** *hifi*

---

STEREO COMPACT DISC PLAYER

# **RCD-965BX**

---

# **TECHNICAL MANUAL**

## **TABLE OF CONTENTS**

Safety Caution.....	1
Chassis Layout.....	1
Specifications.....	2
Alignment.....	2
Wiring Diagram.....	3
Printed Circuit Boards.....	4
Schematic Diagram.....	6
Disassembly Diagram.....	7
PC Board Ass'y Parts List.....	8

**THE ROTEL CO., LTD.**

1-36-8, OHOKAYAMA, MEGURO-KU, TOKYO 152, JAPAN

**ROTEL ELECTRONICS CO., LTD.**

3F-2, NO.35, FU HSING NORTH ROAD, TAIPEI, TAIWAN, REPUBLIC OF CHINA

MN20001974

# Safety Caution

## PROTECTION OF EYES FROM LASER BEAM DURING SERVICING

THIS SET EMPLOYS A LASER. THEREFORE, BE SURE TO FOLLOW CAREFULLY THE INSTRUCTIONS BELOW WHEN SERVICING.

### WARNING !!

WHEN SERVICING, DO NOT APPROACH THE LASER EXIT WITH THE EYE TOO CLOSELY. IN CASE IT IS NECESSARY TO CONFIRM LASER BEAM EMISSION, BE SURE TO OBSERVE FROM A DISTANCE OF MORE THAN 30cm FROM THE SURFACE OF THE OBJECTIVE LENS ON THE OPTICAL PICK-UP BLOCK.

## LASER WARNING LABEL

THE LABEL SHOWN BELOW ARE AFFIXED.

### CAUTION

INVISIBLE LASER RADIATION WHEN OPEN, DO NOT STARE INTO BEAM.

### DANGER

INVISIBLE LASER RADIATION WHEN OPEN, AVOID DIRECT EXPOSURE TO BEAM.

# Chassis Layout

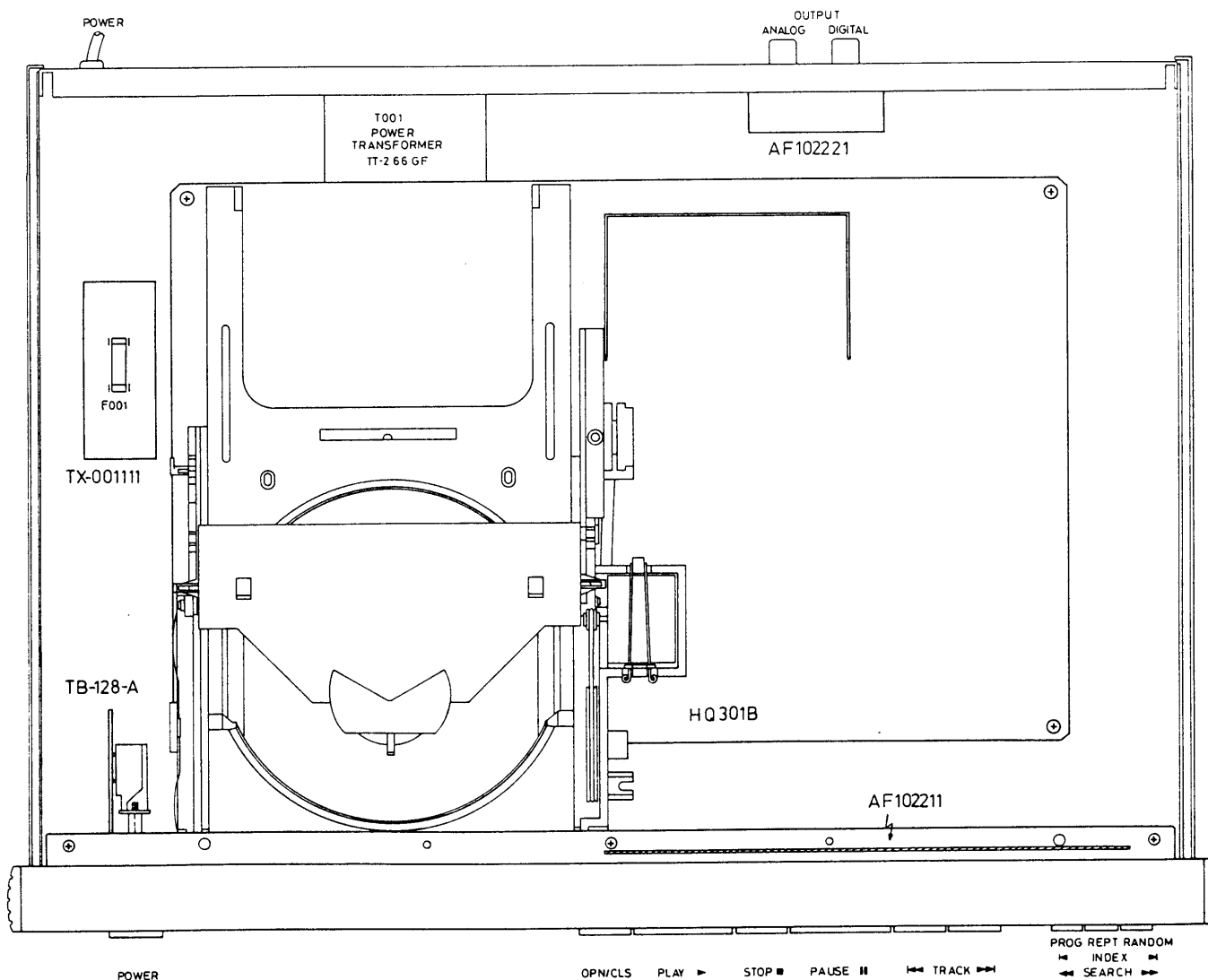

# Specifications

RCD-965BX

## AUDIO

Number of Channels.....2  
Frequency Range.....20 to 20,000 Hz  
Amplitude Linearity..... +/- 0.05 dB  
Channel Unbalance..... +/- 0.5 dB  
Phase Linearity..... +/- 0.5 degrees  
Signal-to-Noise Ratio.....100 dB  
Dynamic Range.....96 dB  
Channel Separation.....100 dB (1 kHz)  
THD + Noise.....0.0025 % (1 kHz)  
Intermodulation Distortion...0.0025 % (1 kHz)  
Out-Band Rejection..... > 60 dB, above 24.1 kHz  
Wow and Flutter.....Quartz crystal precision  
Max Output Level.....2 V rms  
Output Impedance.....200 ohms  
Min Load Impedance.....10 kohms

## DIGITAL OUTPUT

Output Level.....0.5 V P.P.  
Load Impedance.....75 ohms

## MISCELLANEOUS

Power Requirement.....120 V/ 60 Hz, 220 V/ 50 Hz,  
240 V/ 50 Hz (depending on  
destinations)  
Power Consumption.....30 watts  
Dimension (overall).....440 (W) x 92 (H) x 316 (D) mm  
17-3/8" x 3-5/8" x 12-7/16"  
Weight (net).....5.8 Kg / 12.76 lbs

- Specifications and design subject to possible modification without notice.

# Alignment

## ALIGNMENT PROCEDURE FOR THE LASER CURRENT AND THE FOCUS OFFSET (RCD-965BX)

**NOTE 1.** This alignment must be done only if or the monoboard or the CDM is replaced for service purpose.

**NOTE 2.** The given measurement date are only for alignment after service. When checking monokits for these date, different values can be found. This is normal and gives no reason for malfunction.

**NOTE 3.** The used test disc must be a SONY type 4 (YEDS 18).

A. Turn used laser variable resistor R302 in a position that the total resistance of R302 plus R135 is 1 kohm.

Turn the focus variable resistor R301 in the middle position.

B. Switch the power ON and verify that the display light up.

C. Place the test disc in the tray. The test disc must be clean (no finger prints) and may not be damaged.

D. Connect a DC voltmeter over resistor R115, switch the power on, press the PLAY button and check the reading of the DC voltmeter.

E. While the monokit is playing, adjust the laser current with variable resistor R302 at a value of 50 mV +/- 2 mV.

F. Switch the power off and connect a DC voltmeter over capacitor C135, switch the power on, press the PLAY button and check the reading of the DC voltmeter.

G. While the monokit is playing, adjust the focus offset with variable resistor R301 at a value of 400 mV +/- 20 mV.

**REMARK:** It is normal that the focus readout is not stable, but is varying within certain range.

For Service Manuals  
**MAURITRON SERVICES**  
8 Cherry Tree Road, Chinnor  
Oxfordshire, OX9 4QY.  
Tel (01844) 351694  
Fax (01844) 352554  
email:- mauritron@dial.pipex.com

# Wiring Diagram

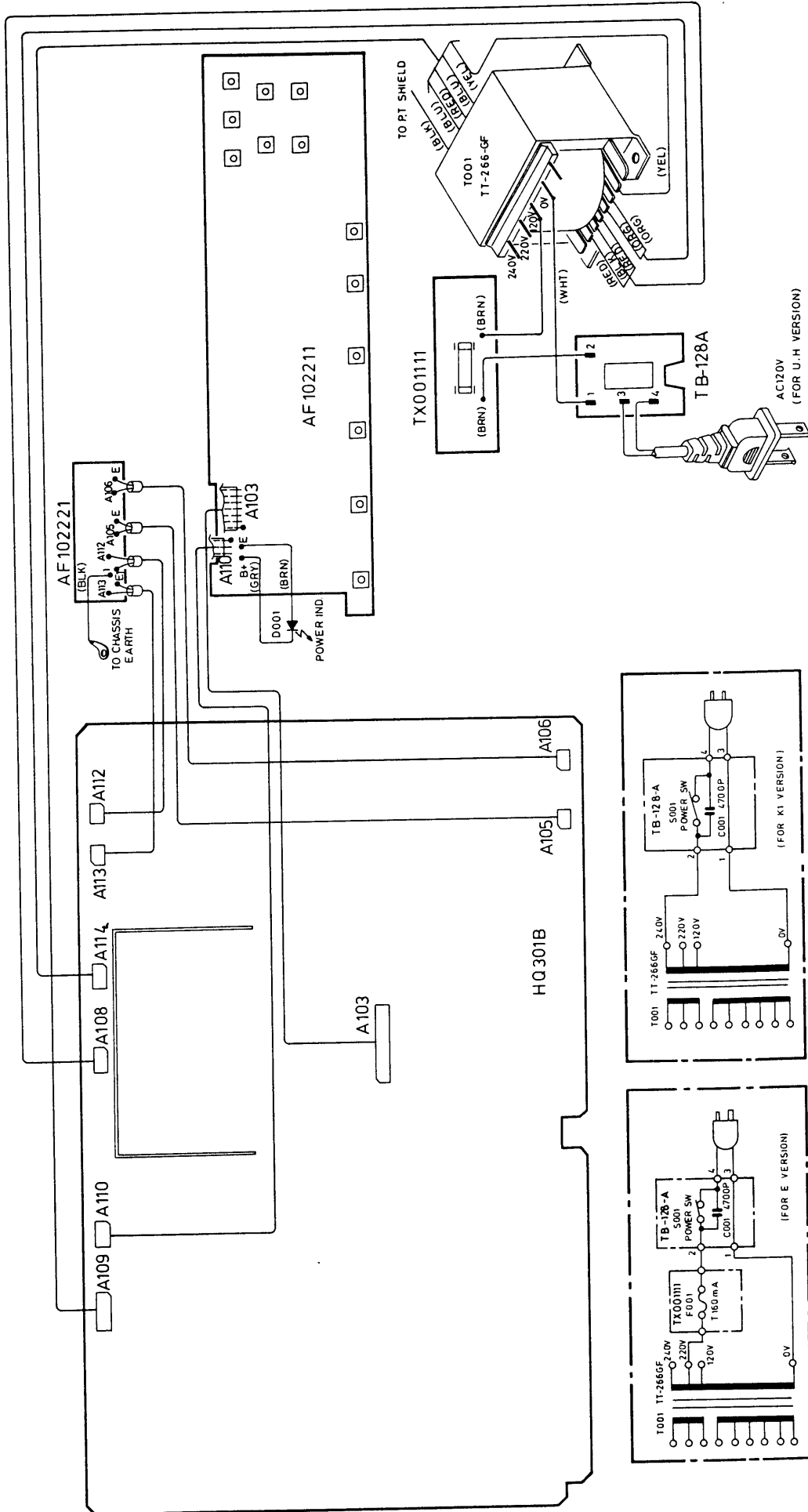

# Printed Circuit Boards

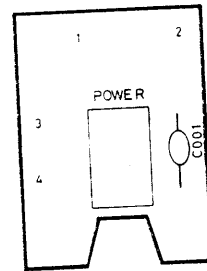
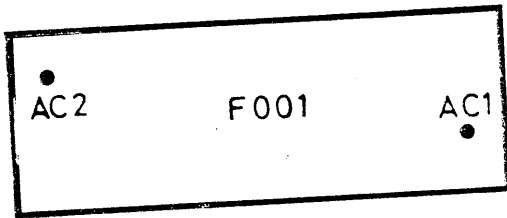
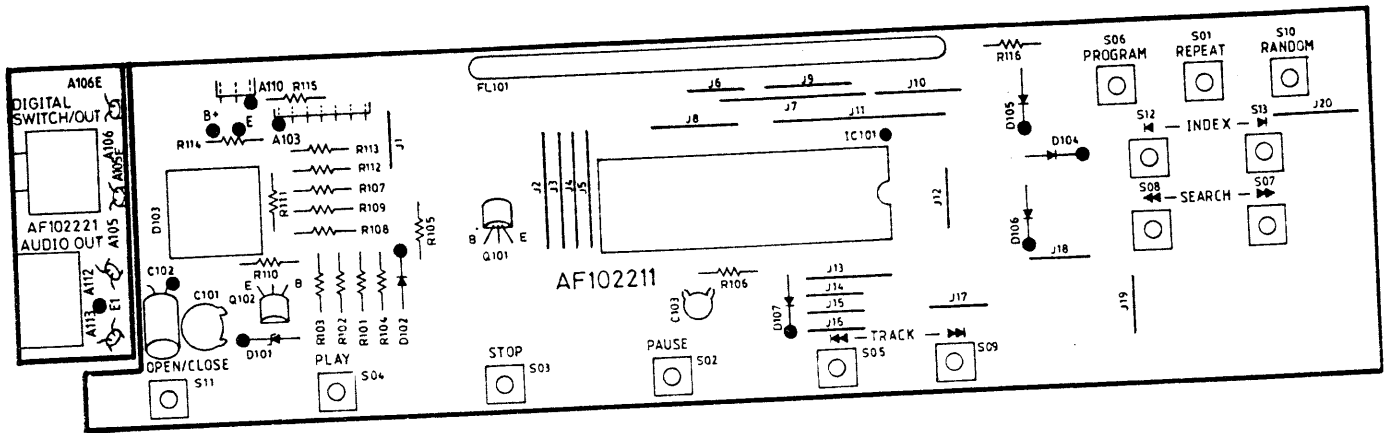

# REMOTE CONTROL HANDSET

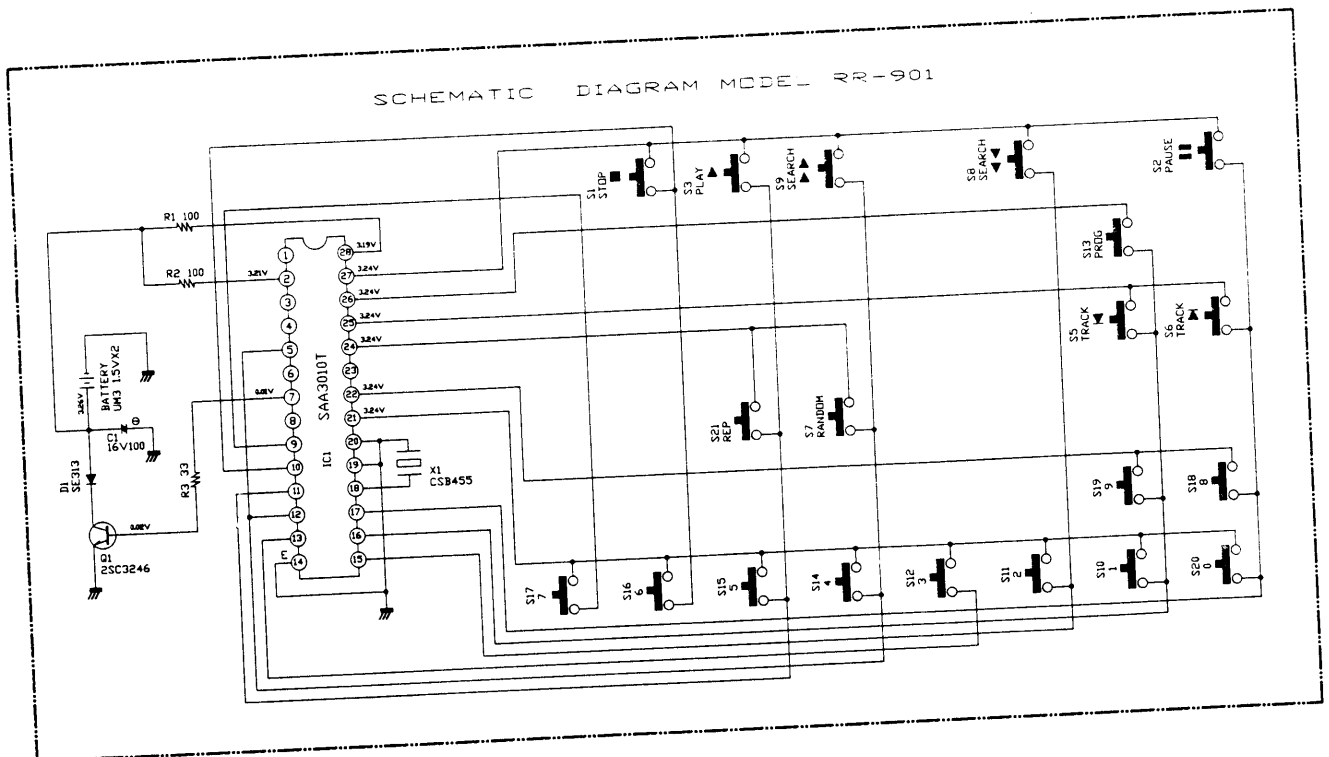

# Printed Circuit Boards

(HQ 301B TOP SIDE)

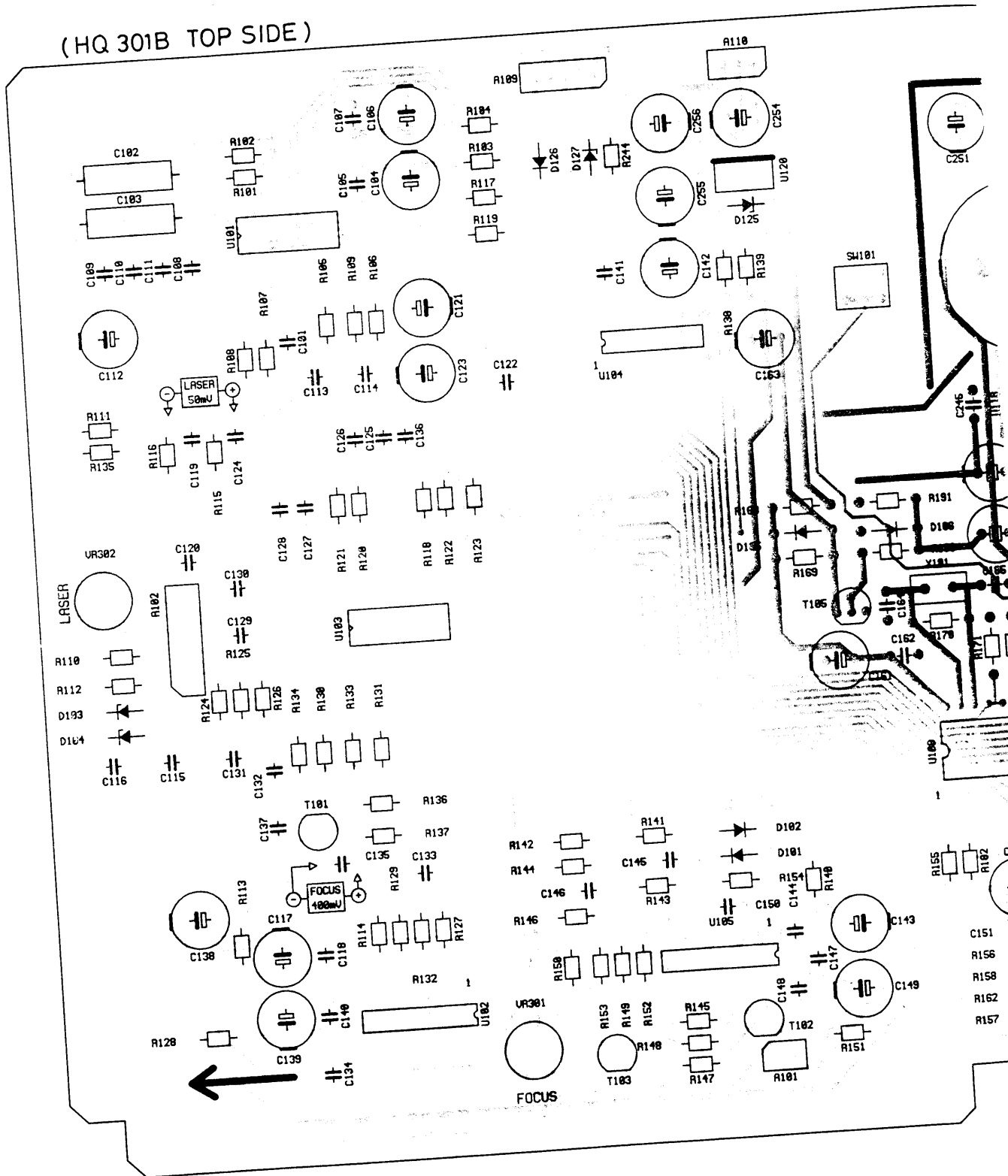

# uit Boards

(TOP SIDE)

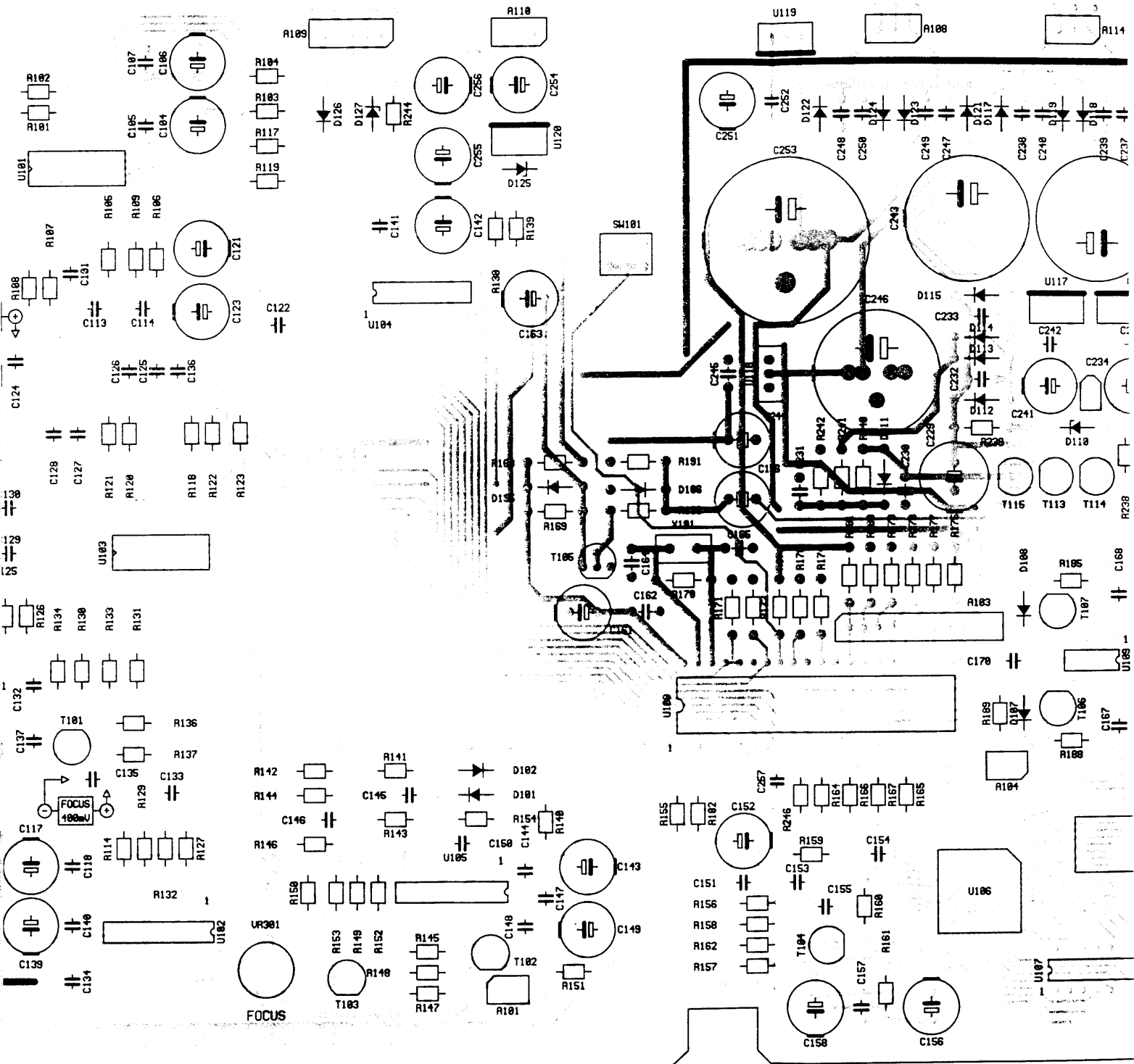

For Service Manuals  
**MAURITRON SERVICES**  
 8 Cherry Tree Road, Chinnor  
 Oxfordshire, OX9 4QY.  
 Tel (01844) 351694  
 Fax (01844) 352554  
 email: mauritron@dial.pipex.com

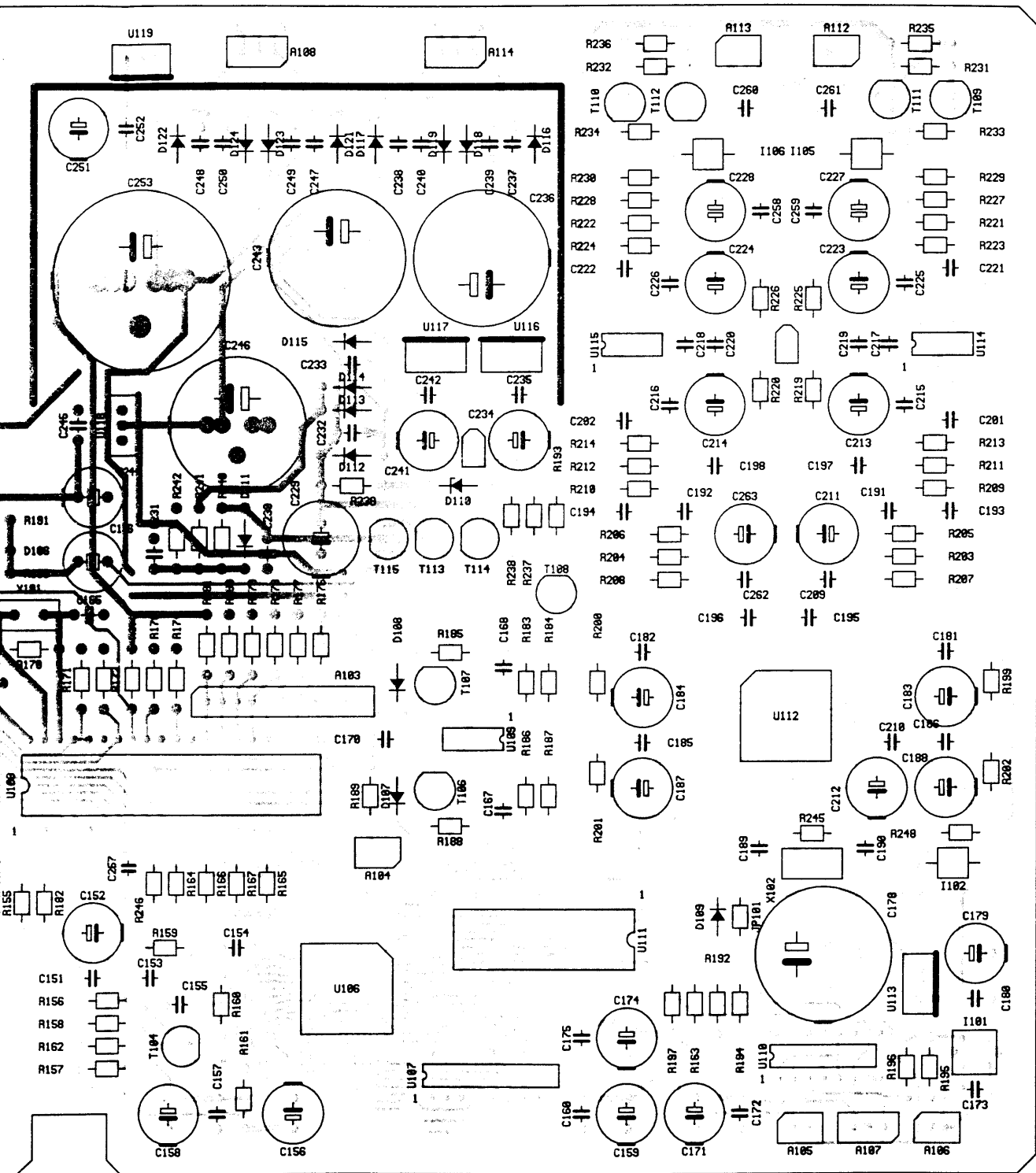





# SCHEMATIC DIAGRAM MODEL RCD-965BX

NOTE 1

FL101 6-MT-139G

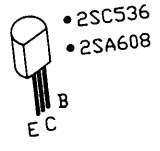
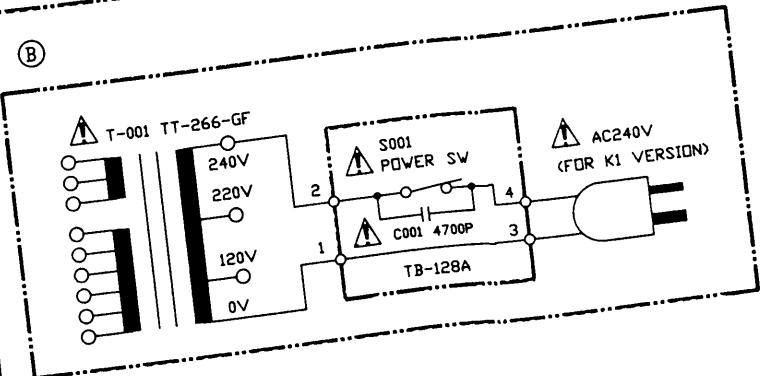
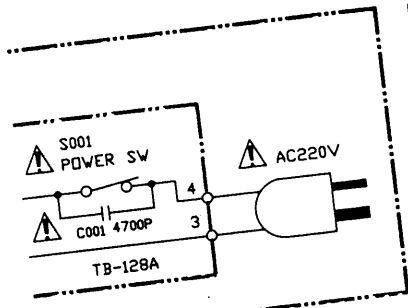
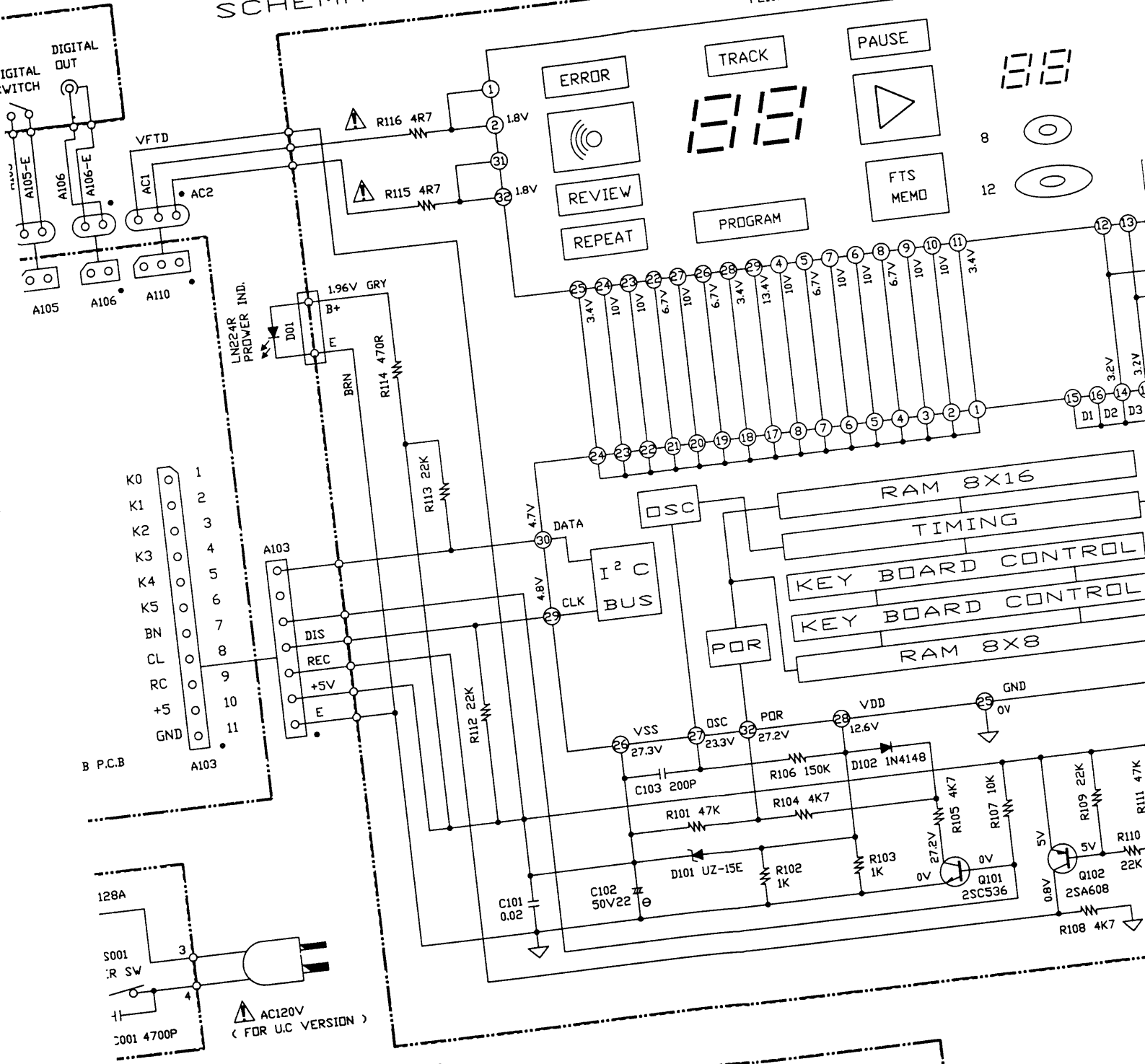

For Service Manual  
**MAURITRON SERVICE**  
 8 Cherry Tree Road, Ch  
 Oxfordshire, OX9 4C  
 Tel (01844) 351694  
 Fax (01844) 352555  
 email: mauritron@dial.pip

FL101 6-MT-139G

AF102211

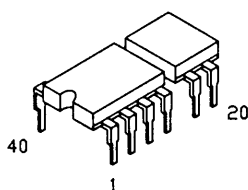
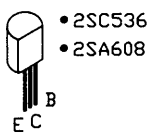
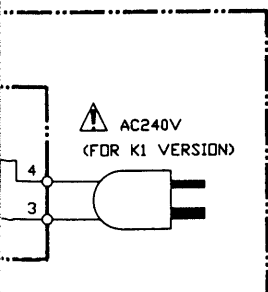
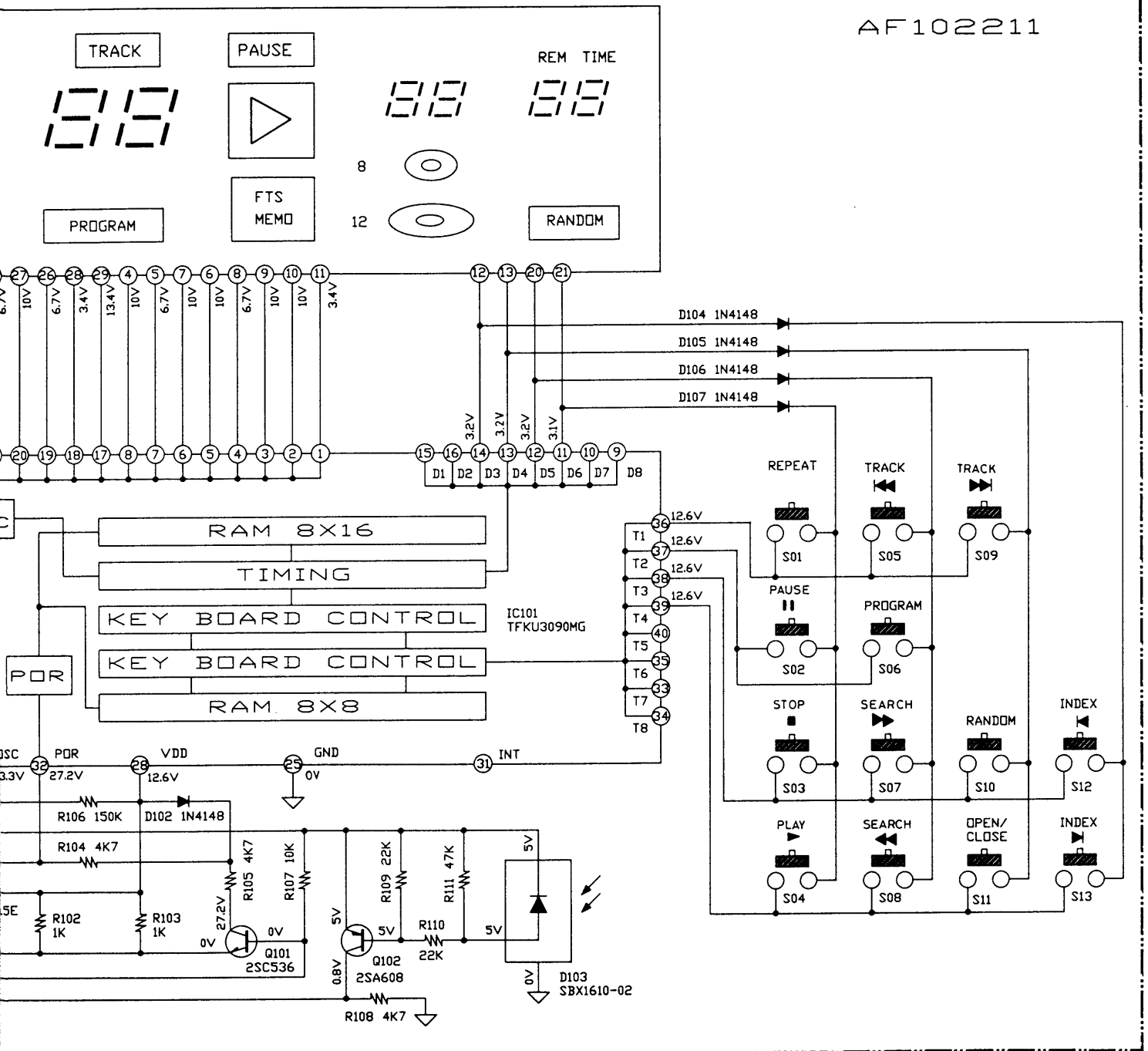

• TFKU3090MG

**INSTRUCTION FOR SERVICING PERSONNEL:**

- 1). USE ONLY REPLACEMENT PARTS THAT HAVE THE CRITICAL CHARACTERISTICS RECOMMENDED BY MANUFACTURER.
- 2). MAKE LEAKAGE-CURRENT OR RESISTANCE MEASUREMENTS TO DETERMINE THAT EXPOSED PARTS ARE ACCEPTABLY INSULATED FROM THE AC SUPPLY CIRCUIT BEFORE RETURNING THE UNIT TO THE CUSTOMER.

# Disassembly Diagram

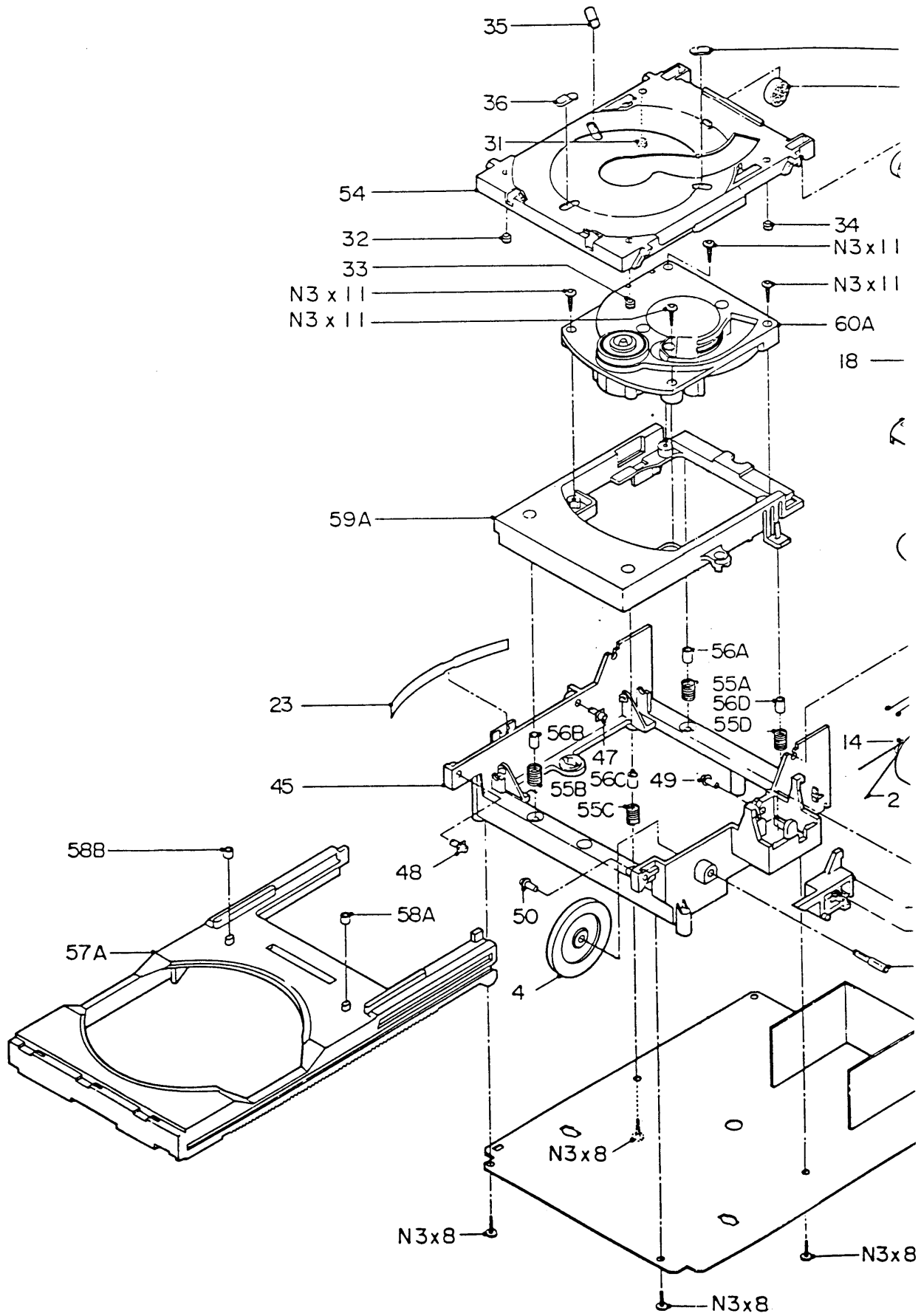

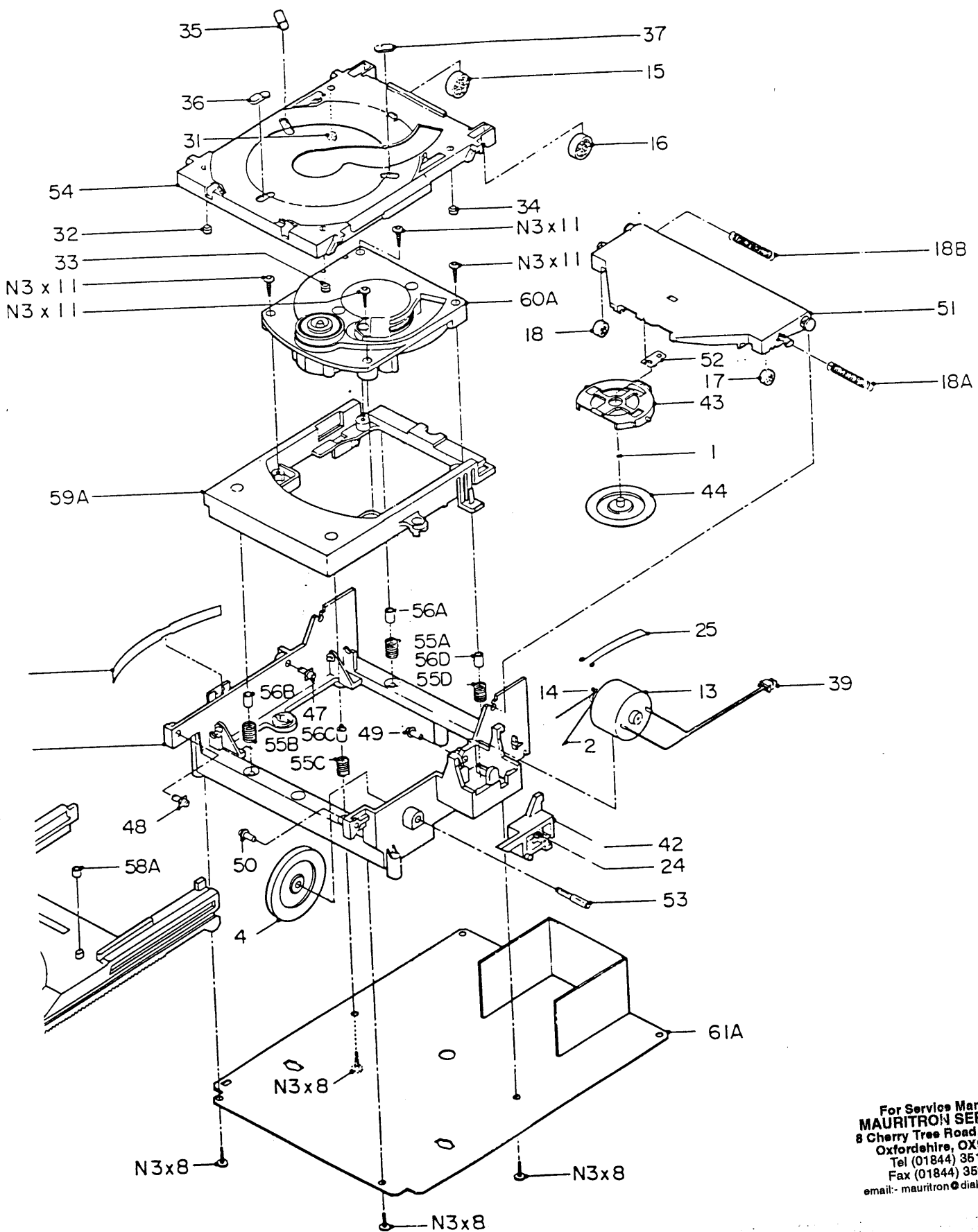

- 19
- 1
- 2
- 4
- 13
- 14
- 15
- 17
- 23
- 24
- 25
- 31
- 33
- 35
- 39
- 42
- 43
- 44
- 45
- 47
- 49
- 51
- 52
- 53
- 54
- 18.
- 55.
- 55C
- 56.
- 56C
- 58.
- 57.
- 59.
- 60
- N3

For Service Manuals  
**MAURITRON SERVICES**  
 8 Cherry Tree Road, Chinnor  
 Oxfordshire, OX9 4QY.  
 Tel (01844) 351694  
 Fax (01844) 352554  
 email: mauritron@dial.pipex.com

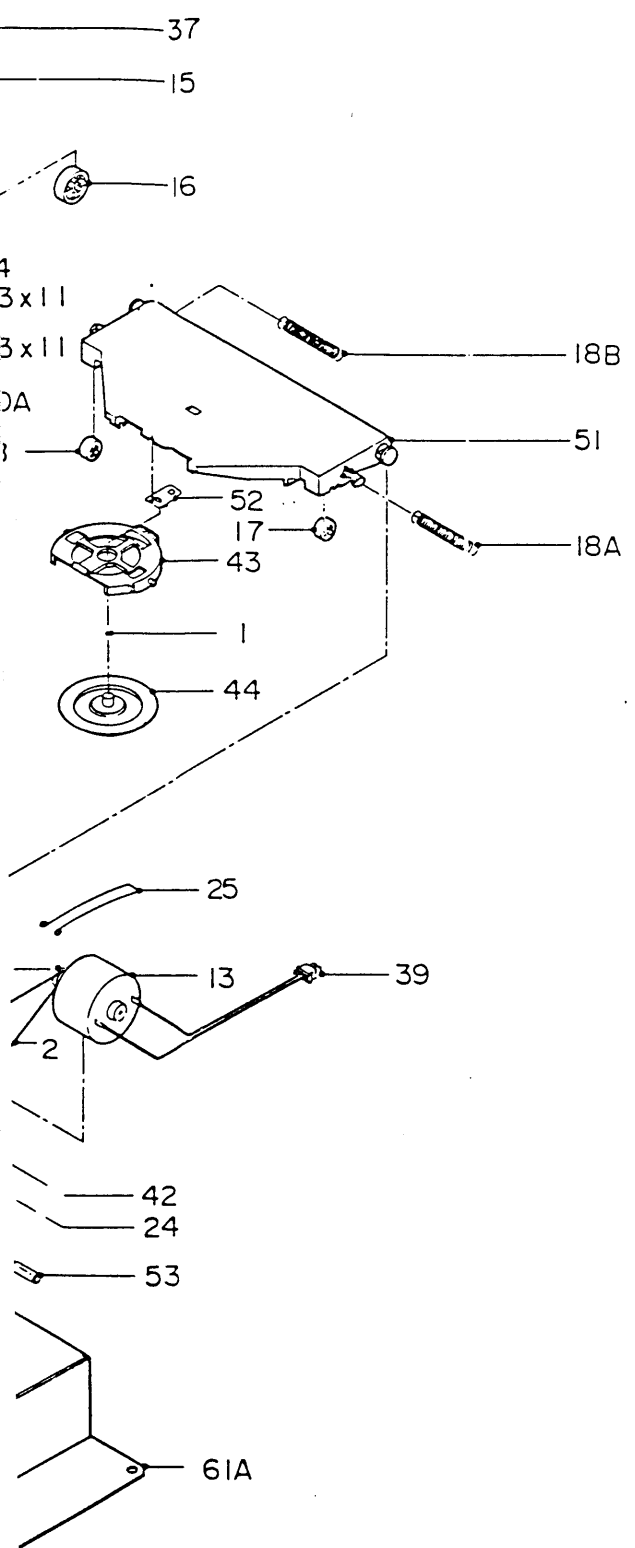

ITEM	PART NO.	DESCRIPTION
1	013 40001	BALL 3F
2	017 40002	BELT
4	077 30005	GEAR WHEEL
13	118 40001	DC MOTOR
14	139 40003	PULLEY (MOTOR)
15, 16	151 40001	ROLLER
17, 18	151 40002	ROLLER
23	172 30015	FLAT SPRING
24	172 40013	COMPRESSION SPRING
25	172 40014	SPRING
31, 32	208 40014	TULE
33, 34	208 40001	TULE
35-37	208 40002	ORNAMENTAL TULE
39	241 40003	LEAD ASS'Y
42	255 30003	SWITCH BRACKET
43	258 20004	CENTRING RING
44	258 30003A	CARRIER
45	259 10002	CHASSIS
47, 48	271 30003	GUIDE
49, 50	271 30004	GUIDE
51	300 10004A	LID
52	300 40005	PIVOT PLATE
53	316 40005	SHAFT
54	317 10003A	LIFT PLATE
18A, 18B	172 40018	TENSION SPRING
55A, 55B		
55C, 55D	172 40016	COMPRESSION SPRING
56A, 56B		
56C, 56D	078 40002	SUSPENSION GROMMET
58A, 58B	078 40003	DAMPING GROMMET
57A	317 10004	TRAY ASS'Y
59A	259 10003A	SUPPORT PIECE
60A	480 32403	CDM4 MINI (DC) ACCESSORY
N3x11	160 40002	PLAST SCR M3x8

# Parts List





NOTE: THE COMPONENTS IDENTIFIED BY  $\triangle$  MARK ARE FOR SAFETY. REPLACE ONLY WITH ORIGINAL PARTS. DO NOT SUBSTITUTE.





SYMBOL	PARTS NO.	DESCRIPTION
AF102211 PCB ASSEMBLY		
R101	RD24702822	R, CARBON 47K 1/4W J
R102, 103	RD21001821	R, CARBON 1K 1/4W J
R104, 105	RD24701829	R, CARBON 4.7K 1/4W J
R106	RD21503826	R, CARBON 150K 1/4W J
R107	RD21002825	R, CARBON 10K 1/4W J
R108	RD24701829	R, CARBON 4.7K 1/4W J
R109, 110	RD22202822	R, CARBON 22K 1/4W J
R111	RD24702822	R, CARBON 47K 1/4W J
R112, 113	RD22202822	R, CARBON 22K 1/4W J
R114	RD24700825	R, CARBON 470 1/4W J
R115, 116	RD24708824	R, CARBON 4.7 1/4W J
C101	CC02009456	CAP. CERAMIC 0.02uF 50V
C102	CE02206508	CAP. ELEC. 22uF 50V
C103	CC02011430	CAP. CERAMIC 200P 50V
D101	DD20000193	DIODE RD-15E
D102	DD80000021	DIODE IN4148-86
D103	IC00002030	REMOTE RECEIVER SBX1610-02
D104-107	IC80000021	DIODE IN4148-86
Q101	TR30000327	TRANSISTOR 2SC536
Q102	TR10000126	TRANSISTOR 2SA608K
IC101	IC00002272	IC TMS3767
FL101	DD40001142	FL TUBE 6-MT-139G
S01-S13	SH60000240	KEY BOARD SW 4TR-2343
AF102221 PCB ASSEMBLY		
	JP01000115	1P PIN JACK 4TR-2487#3
	JP02000211	2P PIN JACK 4TR-2166#4
TX001111 PCB ASSEMBLY		
F001	FU25000065	FUSE 250V 300mA UL-CSA $\triangle$
	FU23000261	FUSE 250V T 160mA S $\triangle$
TB-128A PCB ASSEMBLY		
S001	SH40000120	POWER SW C-3600B-T $\triangle$
C001	CK00000035	SPARK KILLER DE7150F472M $\triangle$
HQ301B MONOBOARD PCB		
D101, 102	058 40004	DIODE IN4002
D103, 104	058 40009	ZENER HZ7C2 (7V5)
D105, 106	058 40002	DIODE IN4148
D107-109	058 40004	DIODE IN4002
D110	058 40014	ZENER HZ4B2 (3V9)
D111	058 40002	DIODE IN4148
D112	058 40004	DIODE IN4002
D113, 114	058 40002	DIODE IN4148
D115-124	058 40004	DIODE IN4002
D125	058 40013	ZENER HZ15-3 (15V)
D126	058 40004	DIODE IN4002
D127	058 40022	ZENER HZ6C2 (6V2)
I101	198 40001	DIG OUT TRANSFORMER
I102	089 31479	COIL LAL04 4MUH7 PM10
I105	089 41680	COIL LAL104 68MUH PM10
I106	089 41680	COIL LAL04 68MUH PM10
M101	040 40001	SPRING CLIP
M102	079 40001	SILICON GREASE
M103	081 40007	HEAT SINK
M104	099 40078	LABEL
M105	179 40001	TACT SWITCH (4.3MM)
M106	511 16004	PRINTED CIRCUIT BOARD HQ301B
T101	201 40012	TRANS BC338-25
T102	201 40002	TRANS BC558B
T103	201 40002	TRANS BC558B
T104	201 40006	TRANS BF450
T105	201 40001	TRANS BC548B

SYMBOL	PARTS NO.	DESCRIPTION
T106	201 40012	TRANS BC338-25
T107	201 40011	TRANS BC328-25
T108	201 40013	TRANS BC338-40
T109	201 40013	TRANS BC338-40
T110	201 40013	TRANS BC338-40
T111	201 40013	TRANS BC338-40
T112	201 40013	TRANS BC338-40
T113	201 40001	TRANS BC548B
T114	201 40002	TRANS BC558B
T115	201 40015	TRANS BC548C
U101	088 44011	IC TDA8809T/C2
U102	088 43048	IC TCA0372/DP2
U103	088 44010	IC TDA8808T/C3
U104	088 42003	IC 74HCT00
U105	088 43048	IC TCA0372/DP2
U106	088 44015	IC SAA7310GP
U107	088 41002	IC UPD41416-20 16Kx4
U108	088 44021	IC MC68HC05C8/P110
U109	088 44009	IC NJM5534DD
U110	088 42002	IC 74HCT08P
U111	088 44007	IC SAA7220P/B
U112	088 44049	IC SAA7323GP
U113	088 43012	IC MC7805ACT (5V2)
U114	088 44031	IC XR5534A
U115	088 44031	IC XR5534A
U116	088 43035	IC MC79M15CT
U117	088 43023	IC MC78M15CT
U118	088 43033	IC MC79M05CT
U119	088 43012	IC MC7805ACT (5V2)
U120	088 43022	IC MC78M12CT
X101	148 40002	CER RES 4.0000MHZ
X102	052 42002	CRYSTAL 11.2896MHZHC-49/U
OTHERS		
AF50000030		FRONT CHASSIS 2TQO-2
AM00001951		CHASSIS BODY 2TQO-3#2
AR50000071		PRINTED REAR CHASSIS TRP-595
DI00001223		COMPACT DISC MONOKIT HQ301B
PT26607105		POWER TRANSFORMER
		TT-266-GF $\triangle$
FT00000229		PLASTIC FOOT 4TSH-19#2
		50Fx14H
SP40000693		P.T PLASTIC PLATE 4TR-2701
CD00000216		AC CORD SPT-2 AWG#18
		4TR-670#4 (U, C, A) $\triangle$
CD00000292		AC POWER CORD UP-401F
		4TR-2631#1 (D) $\triangle$
CD00000048		AC POWER CORD 4TR-1037
		(H, E, K2) $\triangle$
CD00000115		AC POWER CORD C-3763-T
		(G) $\triangle$
NP00001949		NAME STICKER AC 120V
		4TR-2828#1 TNP-382
NP00001962		NAME STICKER AC 240V
		4TR-2828#3 TNP-384
NP00001974		NAME STICKER AC 120V-C
		4TR-2828#4 TNP-385
NP00001950		NAME STICKER AC 220V
		4TR-2828#2 TNP-383
NP00001998		NAME STICKER AC 230V
		4TR-2828#5 TNP-389
AA50000077		FRONT PANEL 2TQP-1 TFP-627
AW00000587		PANEL WINDOW 4TQO-7
BU00001145		POWER RING W/LED 4TQF-13
		14x14
KB20002796		TACT BUTTON 3 KEY 3TQP-2
KB20002711		TACT BUTTON 6 KEY 3TQK-8
KB20002784		TACT BUTTON 2 KEY 3TQO-4

# Parts List

BY  MARK ARE FOR SAFFTY.REPLACE ONLY WITH ORIGINAL PARTS.DO NOT SUBSTITUTE.

OPTION
LY
ON 47K 1/4W J
ON 1K 1/4W J
ON 4.7K 1/4W J
ON 150K 1/4W J
ON 10K 1/4W J
ON 4.7K 1/4W J
ON 22K 1/4W J
ON 47K 1/4W J
ON 22K 1/4W J
ON 470 1/4W J
ON 4.7 1/4W J
RAMIC 0.02uF 50V
EC. 22uF 50V
RAMIC 200P 50V
RD-15E
IN4148-86
RECEIVER SBX1610-02
IN4148-86
STOR 2SC536
STOR 2SA608K
3767
E 6-MT-139G
ARD SW 4TR-2343
LY
JACK 4TR-2487#3
JACK 4TR-2166#4
LY
50V 300mA UL-CSA 
50V T 160mA S 
Y
SW C-3600B-T 
KILLER DE7150F472M 
B
IN4002
HZ7C2 (7V5)
IN4148
IN4002
HZ4B2 (3V9)
IN4148
IN4002
IN4148
IN4002
HZ15-3 (15V)
IN4002
HZ6C2 (6V2)
T TRANSFORMER
AL04 4MUH7 PM10
AL04 68MUH PM10
AL04 68MUH PM10
CLIP
N GREASE
INK
WITCH (4.3MM)
D CIRCUIT BOARD HQ301B
BC338-25
BC558B
BC558B
BF450
BC548B

SYMBOL	PARTS NO.	DESCRIPTION
T106	201 40012	TRANS BC338-25
T107	201 40011	TRANS BC328-25
T108	201 40013	TRANS BC338-40
T109	201 40013	TRANS BC338-40
T110	201 40013	TRANS BC338-40
T111	201 40013	TRANS BC338-40
T112	201 40013	TRANS BC338-40
T113	201 40001	TRANS BC548B
T114	201 40002	TRANS BC558B
T115	201 40015	TRANS BC548C
U101	088 44011	IC TDA8809T/C2
U102	088 43048	IC TCA0372/DP2
U103	088 44010	IC TDA8808T/C3
U104	088 42003	IC 74HCT00
U105	088 43048	IC TCA0372/DP2
U106	088 44015	IC SAA7310GP
U107	088 41002	IC UPD41416-20 16Kx4
U108	088 44021	IC MC68HC05C8/P110
U109	088 44009	IC NJM5534DD
U110	088 42002	IC 74HCT08P
U111	088 44007	IC SAA7220P/B
U112	088 44049	IC SAA7323GP
U113	088 43012	IC MC7805ACT (5V2)
U114	088 44031	IC XR5534A
U115	088 44031	IC XR5534A
U116	088 43035	IC MC79M15CT
U117	088 43023	IC MC78M15CT
U118	088 43033	IC MC79M05CT
U119	088 43012	IC MC7805ACT (5V2)
U120	088 43022	IC MC78M12CT
X101	148 40002	CER RES 4.0000MHZ
X102	052 42002	CRYSTAL 11.2896MHZHC-49/U
OTHERS		
AF50000030		FRONT CHASSIS 2TQ0-2
AM00001951		CHASSIS BODY 2TQ0-3#2
AR50000071		PRINTED REAR CHASSIS TRP-595
DI00001223		COMPACT DISC MONOKIT HQ301B
PT26607105		POWER TRANSFORMER
		TT-266-GF 
FT00000229		PLASTIC FOOT 4TSH-19#2
		50Fx14H
SP40000693		P.T PLASTIC PLATE 4TR-2701
CD00000216		AC CORD SPT-2 AWG#18
		4TR-670#4 (U,C,A) 
CD00000292		AC POWER CORD UP-401F
		4TR-2631#1 (D) 
CD00000048		AC POWER CORD 4TR-1037
		(H,E,K2) 
CD00000115		AC POWER CORD C-3763-T
		(G) 
NP00001949		NAME STICKER AC 120V
		4TR-2828#1 TNP-382
NP00001962		NAME STICKER AC 240V
		4TR-2828#3 TNP-384
NP00001974		NAME STICKER AC 120V-C
		4TR-2828#4 TNP-385
NP00001950		NAME STICKER AC 220V
		4TR-2828#2 TNP-383
NP00001998		NAME STICKER AC 230V
		4TR-2828#5 TNP-389
AA50000077		FRONT PANEL 2TQP-1 TFP-627
AW00000587		PANEL WINDOW 4TQ0-7
BU00001145		POWER RING W/LED 4TQF-13
		14x14
KB20002796		TACT BUTTON 3 KEY 3TQP-2
KB20002711		TACT BUTTON 6 KEY 3TQK-8
KB20002784		TACT BUTTON 2 KEY 3TQ0-4

SYMBOL	PARTS NO.	DESCRIPTION
	OM10001272	ORNAME
	OM10001387	CD ALUM
	OM10001399	CD PLAS
	KB20002681	POWER B
	OM70000065	PUSH BU
		4TTL-15
	OM70000168	FILTER
		83x32x2
	OM70000193	FILTER
		22x14x2
	AU00001262	TOP COV
	OM10001417	FL ORN
		4TQ0-8#
	DD40000095	L.E.D S
	SRO0000882	UPPER C
	MN10002860	OWNER'S
	PLO0001099	STYROL
		2TTF-9A
	TN10003847	INSIDE



# Parts List

STITUTE.

SYMBOL	PARTS NO.	DESCRIPTION
	OM10001272	ORNAMENTAL SIDE 4TR-2797#2
	OM10001387	CD ALUM. DOOR 4TQO-6
	OM10001399	CD PLASTIC DOOR 3TQO-5
	KB20002681	POWER BUTTON 4TQF-15 14x14
	OM70000065	PUSH BUTTON CONNECTOR 4TTL-15
	OM70000168	FILTER BOARD 4TSJ-9#2 83x32x2T
	OM70000193	FILTER BOARD 4TSJ-9#3 22x14x2T
	AU00001262	TOP COVER 3TTF-5#8
	OM10001417	FL ORNAMENTAL PLATE 4TQO-8#2 TFP-647
	DD40000095	L.E.D SEL1124R
	SR00000882	UPPER COVER SPACER 4TR-2418
	MN10002860	OWNER'S MANUAL
	PL00001099	STYROL SIDE MOULDING 2TTF-9A#2 TZ-165-1
	TN10003847	INSIDE CARTON 4TR-2854#2

-49/U

2  
TRP-595

HQ301B

#2

R-2701

△  
F

37

-T

-C

FP-627

F-13

QP-2

QK-8

QO-4



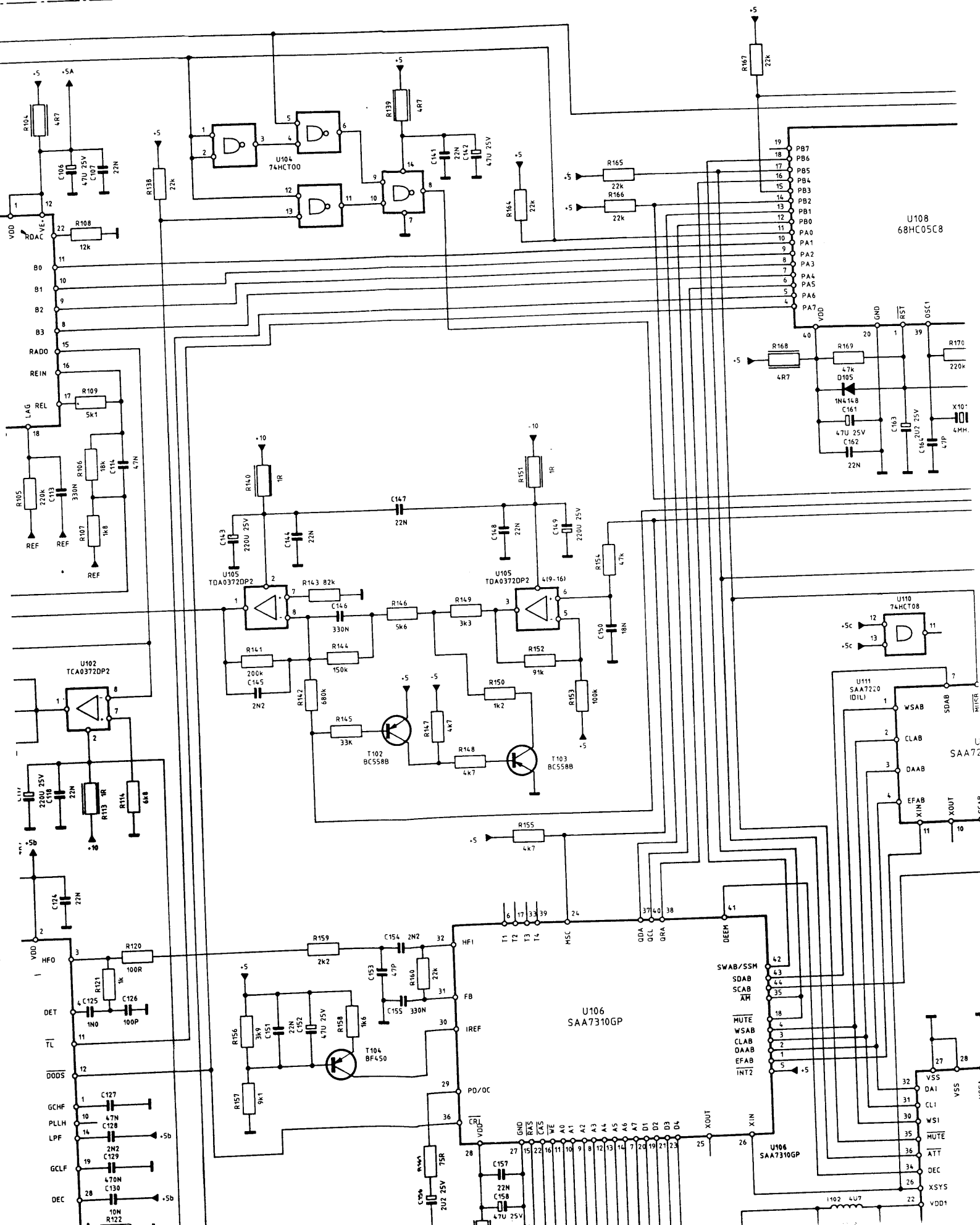

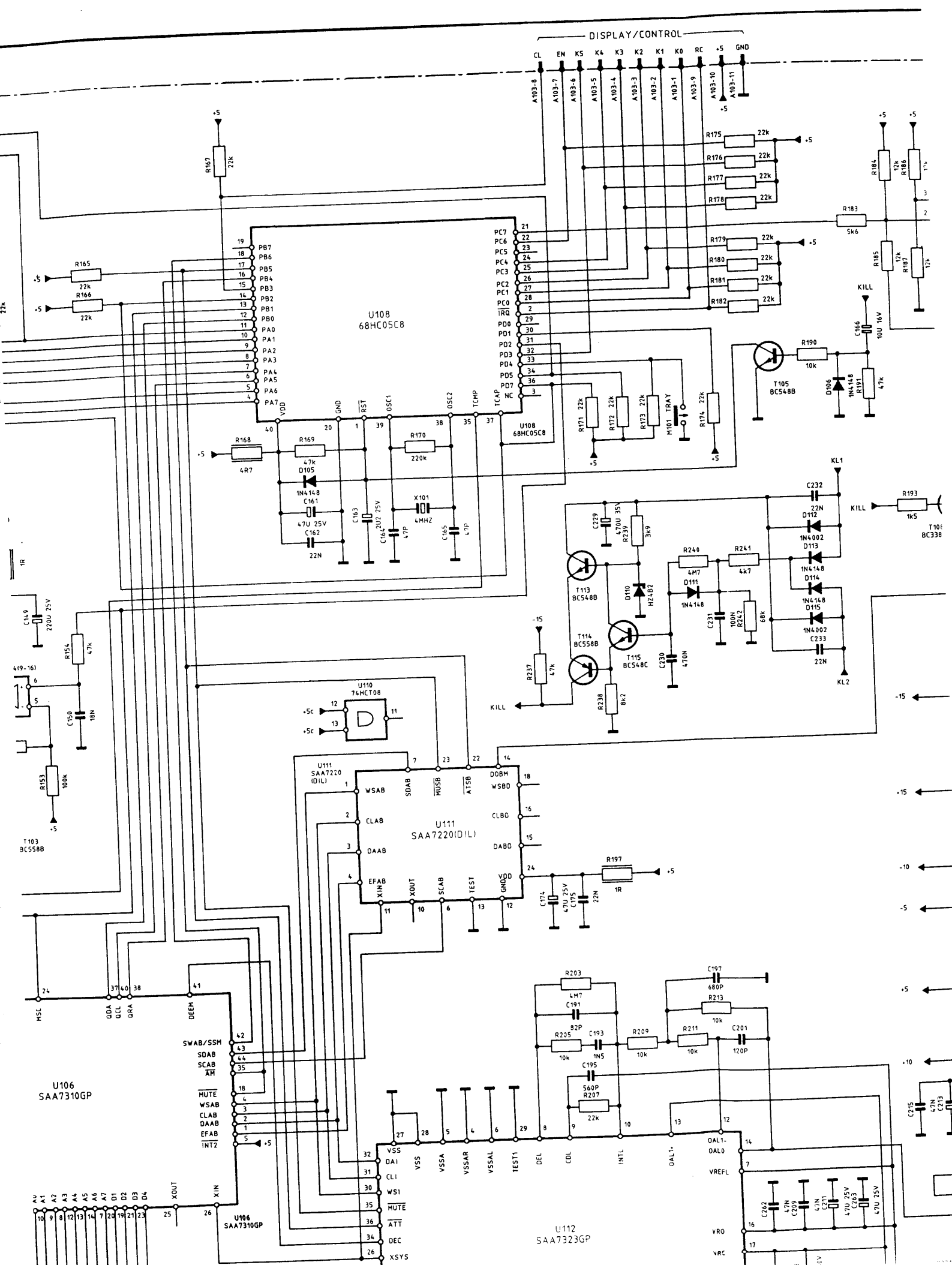

DISPLAY/CONTROL

U108  
68HC05C8

U111  
SAA7220(IDIL)

U106  
SAA7310GP

U112  
SAA7323GP

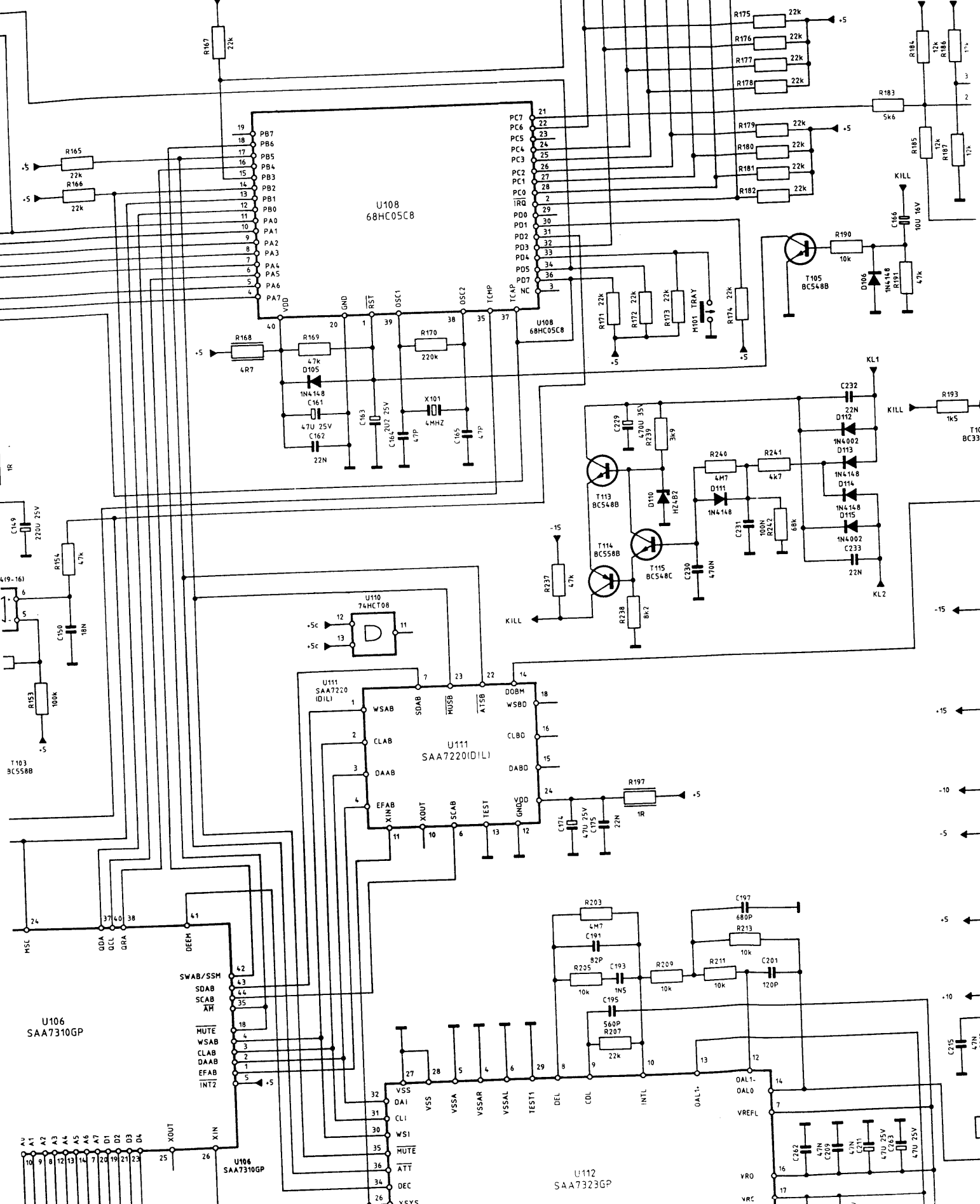

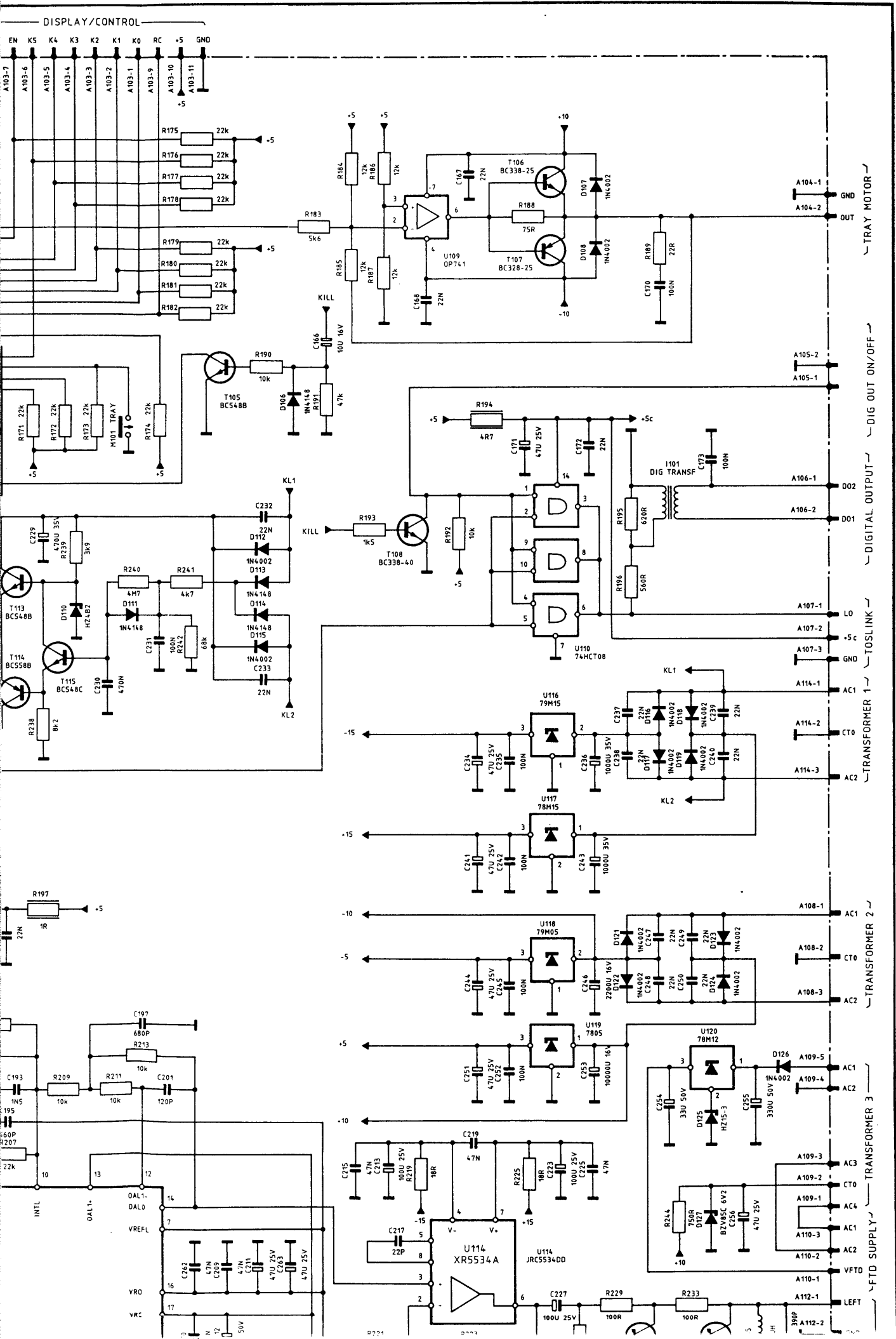

DISC DRIVE

MECHANISM

FOCUS

LASER

RADIAL SPINDLE MOTOR

