

Quality Uncompromised

ROTEL®

Technical Manual



STEREO CASSETTE TAPE DECK

RD-820

TABLE OF CONTENTS

Chassis Layout	2	Repair Parts List	8
Playback System Adjustments	3	Schematic Diagram	9
Recording System Adjustments	5	Wiring Diagram	11
REC/PB System Adjustments	6	Disassembly Diagram (1/2)	13
Block Diagram	7	Disassembly Diagram (2/2)	15

INHALTSVERZICHMIS

Chassis-Anordnung	2	Reparaturteilliste	8
Wiedergabepegels-Einstellung	3	Schaltungsschema	9
Aufnahmesystems-Einstellung	5	Drahtleitung Diagramm	11
Aufnahmesystems und Wiedergabepegels-Einstellung	6	Illustration des Auseinanderbaus (1/2)	13
Blockschaltbild	7	Illustration des Auseinanderbaus (2/2)	15

TABLE DES MATIERES

Installation du châssis	2	Liste des pièces de rechange	8
Réglages de système de la reproduction	4	Diagramme de schématique	9
Réglages du système de l'enregistrement	5	Diagramme de connexion	11
Reglages de système de L'enregistrement/reproduction	7	Schéma de démontage (1/2)	13
Schéma symoptique	7	Schéma de démontage (2/2)	15

THE ROTEL CO., LTD.
ROTEL ELECTRONICS CO., LTD.
ROTEL OF AMERICA, INC.
ROTEL HI FI LIMITED.

1-36-8 OHOKAYAMA, MEGURO-KU, TOKYO 152, JAPAN
2ND FLOOR, EVERGLORY BLDG., NO. 305, SECTION 3,
NANKING E. ROAD, TAIPEI, TAIWAN, REPUBLIC OF CHINA

13518 SO. NORMANDIE, GARDENA, CALIF. 90249, U.S.A.
2-4 ERICA ROAD, STACEY BUSHES, MILTON KEYNES,
BUCKINGHAMSHIRE, ENGLAND

Printed in Taiwan '82 JUL. 082TMRD-820

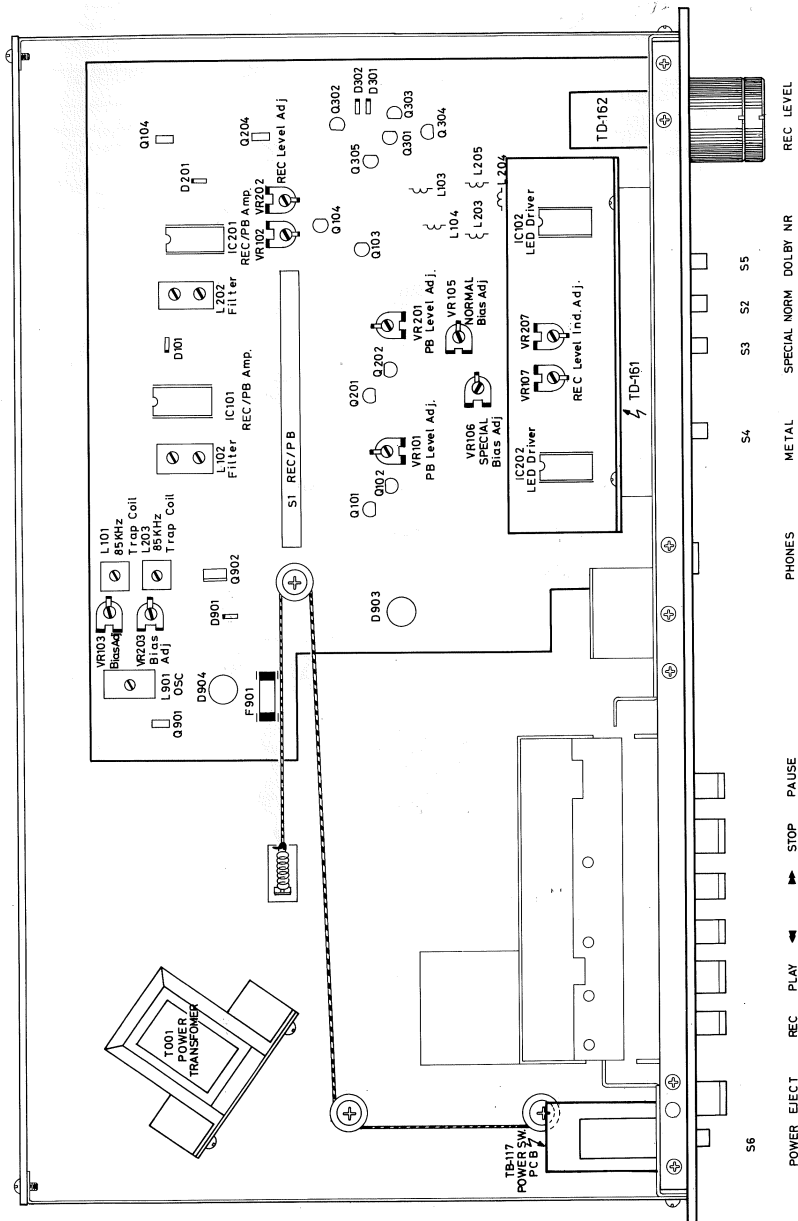

Instruments: Oscilloscope, AC VTVM, Frequency Counter and Test Tape

Conditions: Oscilloscope, AC VTVM and Frequency Counter . . . LINE OUT Tape Selector . . . NORMAL Dolby NR . . . OFF

Adjustment Item	Test Tape	Adjust	Adjust for
Azimuth	LCT-3004-C	REC/PB head screw	Obtain largest wave form on Oscilloscope for both channels (Fig. 1)
Dolby Level	LCT-7001	VR101 (L-ch) VR102 (R-ch)	AC VTVM reads 580mV at TP1, TP2.
LED Calibration		VR107 (L-ch) VR207 (R-ch)	The LEDs indicator corresponds with the 0dB LED. (Fig. 2)
Playback EQ Check	LCT-3009-C		Output Level difference between 40Hz, 1KHz and 10KHz signal is within ± 3.0 dB
Tape Speed Deflection Check/Tape Speed Adjust	LCT-3001		Check that allowable margin of deflection at middle of or at the end of winding is in the range of $\pm 2\% - 1\%$ (at 3000Hz allowable margin of deflection of speed is 3060-2970) If Tape Speed deflection surpasses the above range adjust speed of Motor (Fig. 3)

Wiedergabepegels-Einstellung

Instrumente: Oszillograph, Wechselspannungsvoltmeter, Frequenz-Zähler und Test-cassette

Bedienung: Oszillograph, Wechselspannungsvoltmeter und Frequenz-Zähler . . . LINE OUT, Bank-Wahler . . . NORMAL
Dolby NR Taste . . . OFF

Einstellungsteil	Test-Cassette	Einstellung	Einstellungszweck
Azimuth	LCT-3004-C	REC/PB Tonkopfschraube	Maximum-Wellenform auf Oszillograph für beiden Kanäle (Abb. 1) erhalten.
Dolby-Regel	LCT-7001	VR101 (L-K) VR102 (R-K)	Wechselspannungsvoltmeter auf 580mV einstellen Bei TP 1, TP 2.
Zähler-LED		VR107 (L-K) VR207 (R-K)	Der LEDs-Anzeiger auf dem 0dB LED. (Abb. 2)
Prüfung der Wiedergabe "EQ"	LCT-3009-C		Ausgangspegelunterschied zwischen 40Hz, 1KHz und 10KHz darf innerhalb ± 3.0 dB betragen.
Überprüfung der Bandgeschwindigkeit /Einstellung der Bandgeschwindigkeitabweichung	LCT-3001		Prüfen, ob Abweichung von der Sollgeschwindigkeit im Bereich $\pm 2\% - 1\%$ liegt (bei 3000 Hz zwischen 3060-2970 Hz). Bei grösser Abweichung Motorgeschwindigkeit nachstellen (Abb. 3)

Instruments: Oscilloscope, Voltmètre électronique

Conditions: Oscilloscope, Voltmètre électronique
selecteur de bande . . . NORMAL

Item de réglage	Bande d'essai
Azimuth	LCT-3004-C
Niveau de Dolby	LCT-7001
Calibrage de LED	LCT-3009-C
Contrôle de l'égalisation de reproduction	LCT-3001
Contrôle de la Variation de la vitesse de bande/réglage de la vitesse	LCT-3001

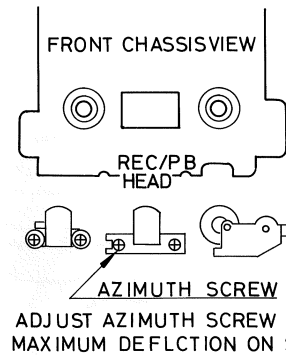

Fig. 1 Azimuth Adjustment
Abb. 1 Azimuteinstellung
Fig. 1 Réglage de l'azimut

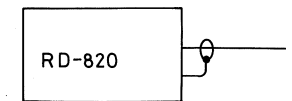

Fig. 3 Tape speed Adjustment
Abb. 3 Einstellung der Bandgeschwindigkeit
Fig. 3 Réglage de la vitesse de défilement

Playback System Adjustments

Instruments: Oscilloscope, AC VTVM, Frequency Counter and Test Tape
 Conditions: Oscilloscope, AC VTVM and Frequency Counter ... LINE OUT Tape Selector ... NORMAL Dolby NR ... OFF

Adjustment Item	Test Tape	Adjust	Adjust for
Azimuth	LCT-3004-C	REC/PB head screw	Obtain largest wave form on Oscilloscope for both channels (Fig. 1)
Dolby Level	LCT-7001	VR101 (L-ch) VR102 (R-ch)	AC VTVM reads 580mV at TP ₁ , TP ₂ .
LED Calibration		VR107 (L-ch) VR207 (R-ch)	The LEDs indicator corresponds with the 0dB LED. (Fig. 2)
Playback EQ Check	LCT-3009-C		Output Level difference between 40Hz, 1KHz and 10KHz signal is within ± 3.0 dB
Tape Speed Deflection Check/Tape Speed Adjust	LCT-3001		Check that allowable margin of deflection at middle of or at the end of winding is in the range of +2% - 1% (at 3000Hz allowable margin of deflection of speed is 3060-2970) If Tape Speed deflection surpasses the above range adjust speed of Motor (Fig. 3)

Wiedergabepegels-Einstellung

Instrumente: Oszillograph, Wechselspannungsvoltmeter, Frequenz-Zähler und Test-cassette
 Bedienung: Oszillograph, Wechselspannungsvoltmeter und Frequenz-Zähler ... LINE OUT, Bank-Wahler ... NORMAL Dolby NR Taste ... OFF

Einstellungsteil	Test-Cassette	Einstellung	Einstellungszweck
Azimuth	LCT-3004-C	REC/PB Tonkppfschraube	Maximum-Wellenform auf Oszillograph für beiden Kanäle (Abb. 1) erhalten.
Dolby-Regel	LCT-7001	VR101 (L-K) VR102 (R-K)	Wechselspannungsvoltmeter auf 580mV einstellen Bei TP ₁ , TP ₂ .
Zähler-LED		VR107 (L-K) VR207 (R-K)	Der LEDs-Anzeiger auf dem 0dB LED. (Abb. 2)
Prüfung der Wiedergabe "EQ"	LCT-3009-C		Ausgangspegelunterschied zwischen 40Hz, 1KHz und 10KHz darf innerhalb + 3.0dB betragen.
Überprüfung der Bandgeschwindigkeit /Einstellung der Bandgeschwindigkeitabweichung	LCT-3001		Prüfen, ob Abweichung von der Sollgeschwindigkeit im Bereich + 2% - 1% liegt (bei 3000 Hz zwischen 3060-2970 Hz). Bei grösser Abweichung Motorgeschwindigkeit nachstellen (Abb. 3)

Réglages de système de la reproduction

Instruments: Oscilloscope, Voltmètre électronique à courant alternatif, Analyseur de fréquence et bande d'essai.
 Conditions: Oscilloscope, Voltmètre électronique à courant alternatif et analyseur de fréquence ... LINE OUT selecteur de bande ... NORMAL Dolby NR ... OFF

Item de réglage	Bande d'essai	Régler	Régler pour
Azimuth	LCT-3004-C	Vis de tête de Enregistrement/reproduction	Obtenir forme d'onde la plus grande sur l'oscilloscope pour les deux canaux (fig. 1)
Niveau de Dolby	LCT-7001	VR101 (canalgauche) VR102 (canal droit)	Le voltmètre électronique à courant Alternatif lit 580 mV à TP ₁ , TP ₂ .
Calibrage de LED		VR107 (canal gauche) VR207 (canal droit)	LEDs Indicateur correspond à la 0dB LED. (fig. 2)
Contrôle de l'égalisation de reproduction	LCT-3009-C		Différence de niveau de sortie entre les signaux 40 Hz, 1 KHz et 10KHz est dans ± 3.0 dB.
Contrôle de la Variation de la vitesse de bande/réglage de la vitesse	LCT-3001		Vérifier que la marge admissible de variation au milieu ou à la fin de bobinage est dans la plage donnée de +2% - 1% (à 3000 Hz marge admissible de variation de la vitesse est 3060-2970). Si la variation de vitesse de bande surpasse la plage donnée ci-dessus, régler la vitesse de moteur. (fig. 3)

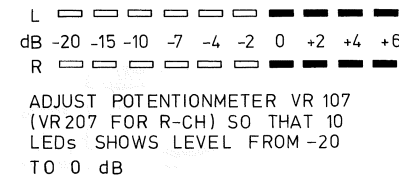
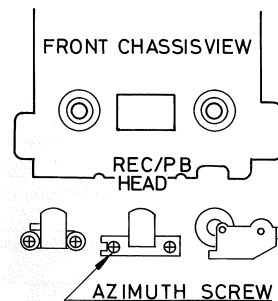
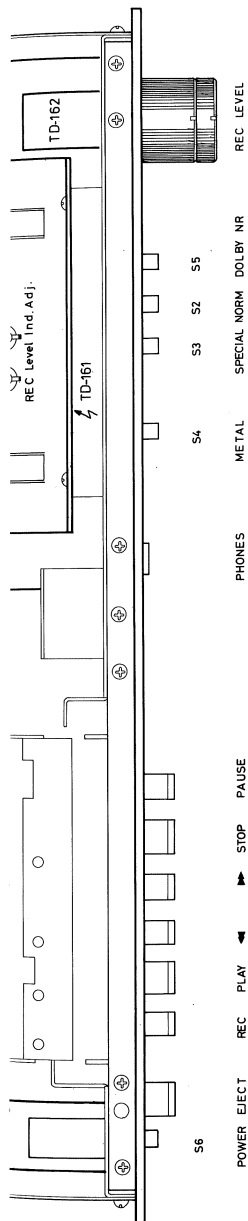

Fig.2 Dolby Level Adjustment
 Abb. 2 Einstellung der Dolby-Regel.
 Fig. 2 Réglage du niveau Dolby

Fig. 1 Azimuth Adjustment
 Abb. 1 Azimuteinstellung
 Fig. 1 Réglage de l'azimuth

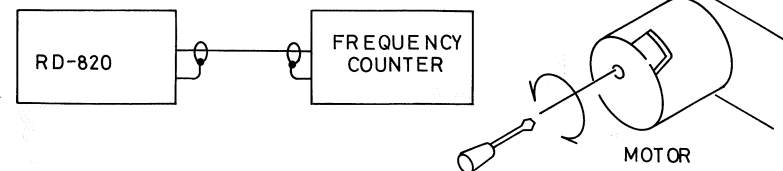

Fig. 3 Tape speed Adjustment
 Abb. 3 Einstellung der Bandgeschwindigkeitabweichung
 Fig. 3 Réglage de la vitesse de défilement de la bande

Recording System Adjustments

Instruments: Oscilloscope, Signal Generator, AC VTVM and Blank Tape
 Conditions: Dolby NR ... OFF REC Level ... Maximum

Adjustment Item	Coupling	Tape Selector	Adjust	Adjust for
Bias Carrier	Oscilloscope ... Point TP 11 (TP12R-ch)	METAL	L101 (L-ch) L201 (R-ch)	Obtain Min. deflection on the Oscilloscope
19KHz Filter	S.G. (400Hz 0dB) ... LINE IN/LINE OUT ... 450mV Changed S.G. to 19KHz Dolby NR ... ON	NORMAL	L102 (L-Ch) L202 (R-Ch)	AC VTVM reads 30dB (Minimum)
Bias Voltage	Oscilloscope ... Point 11 12 (R-ch)	METAL	VR103 (L-Ch) VR203 (R-Ch)	AC VTVM reads 8mV
		SPECIAL	VR106	AC VTVM reads 5mV
		NORMAL	VR105	AC VTVM reads 4mV

Aufnahmesystems-Einstellung

Instruments: Oszillograph, NF-Generator, Wechselspannungsvoltmeter und Leercassette.
 Bedienungen: Dolby NR Taste ... OFF Aufnahmepegelregler ... Maximum

Einstellungsteil	Kupplung	Band-Wähler	Einstellung	Einstellungszweck
Bias-Trägerstrom	Oszillograph ... Punkt TP11(TP12R-K)	METAL	L101 (L-K) L201 (R-K)	Min. Abweichung auf Oszillograph erhalten.
19KHz Filter	NF-Generator (400Hz 0dB) ... an "LINE IN/LINE OUT ... 450mV NF-Generator auf 19 KHz. Dolby NR ... ON	NORMAL	L102 (L-Ch) L202 (R-Ch)	Wechselspannungsvoltmeter auf -30dB einstellen, (Minimum)
Vorspannung	Oszillograph ... Punkt 11(12 R-K)	METAL	VR103 (L-Ch) VR203 (R-Ch)	Wechselspannungsvoltmeter auf 8mV einstellen.
		SPECIAL	VR106	Wechselspannungsvoltmeter auf 5mV einstellen.
		NORMAL	VR105	Wechselspannungsvoltmeter auf 4mV einstellen.

Réglages de système de l'enregistrement

Instruments: Oscilloscope, Générateur de signal, voltmètre électronique à courant alternatif et bande vierge
 Conditions: Dolby NR ... OFF Niveau de l'enregistrement ... maximum

Item de réglage	Accouplement	Selecteur de bande	Régler	Régler pour
Porte-Polarisation	Oscilloscope ... Point TP11(TP12canal droit)	METAL	L-101 (canal gauche) L201 (canal droit)	Obtenir la variation min. sur l'oscilloscope
Filtre 19KHz	Générateur de signal (400Hz 0dB) ... LINE IN/LINE OUT ... 450mV Changé le générateur de signal à 19KHz Dolby NR ... ON	NORMAL	L102 (L-Ch) L202 (R-Ch)	Voltmètre électronique à courant alternatif lit -30dB (minimum)
Voltage de polarisation	Oscilloscope ... Point 11(12 Canal droit)	METAL	VR103 (L-Ch) VR203 (R-Ch)	Voltmètre électronique à courant alternatif lit 8mV
		SPECIAL	VR106	Voltmètre électronique à courant alternatif lit 5mV
		NORMAL	VR105	Voltmètre électronique à courant alternatif lit 4mV

REC/PB System Adjustments

Instruments: Signal Generator, H.D. Analyzer and Blank Tape
 Conditions: Dolby NR ... OFF REC Level ... Maximum PLAY, REC, PAUSE ... ON

Adjustment	Conditions	Adjust	Adjust for
REC/PB Output Level	S.G. (400Hz 0dB) ... LINE IN/LINE OUT ... 450mV Release Pause Button and playback it again.	VR102 (L-ch) VR202 (R-ch)	Recording and Playback level difference must be within ± 1 dB
Distortion Check	S.G. (400Hz 0dB) ... LINE IN/LINE OUT ... 450mV H.D. Analyzer ... LINE OUT Release Pause Button and playback it again.		Check that distortion is within following range. a. METAL Tape ... unter 2% b. SPECIAL Tape ... unter 4% c. NORMAL Tape ... unter 2%
	If the distortion factor exceeds the above, recheck Bias Current Adjustment.		
Frequency Response Check	METAL Tape insert it	VR103 (L-ch) VR203 (R-ch)	40Hz-125Hz ... 5dB 125Hz-10KHz ... 3dB 10KHz-15KHz ... 5dB
	SPECIAL Tape insert it	VR106	
	NORMAL Tape insert it	VR105	40Hz-125Hz ... 5dB 125Hz-10KHz ... 3dB 10KHz-14KHz ... 5dB

Aufnahmesystems-und Wiedergabepiegels-Einstellung

Instruments: NF-Generator, Klirrfaktormessbrücke und Leer-cassette
 Bedienungen: Dolby NR ... OFF Aufnahmepegel ... Maximum
 PLAY, REC, PAUSE Taste ... ON

Einstellung	Bedienungen	Einstellen	Einstellungszweck
Aufnahme/Wiedergabe Ausgangspegel	NF-Generator (400 Hz 0dB) ... LINE IN/LINE OUT ... 450mV Pause-Taste freigeben und spielen es rück noch einmal.	VR102 (L-Ch) VR202 (R-Ch)	Die Differenz der Aufnahme und Wiedergabe-Ausgangspegel innerhalb einer Toleranz von ± 1 dB liegen müssen.
Prüfen des Klirrfaktors	NF-Generator (400 Hz 0dB) ... LINE IN/LINE OUT ... 450mV Klirrfaktormessbrücke ... LINE OUT Pause-Taste freigeben und spielen es rück noch einmal.		Prüfen, ob Klirrfaktor den folgenden Werten entspricht: a. METAL Band ... unter 2% b. SPECIAL Band ... unter 4% c. NORMAL Band ... unter 2%
	Wenn der Klirrfaktor die angegebenen Werte übersteigt, dann Vormagnetisierungstrom prüfen.		
Prüfen des Frequenzgangs	METAL Band einschieben	VR103 (L-Ch) VR203 (R-Ch)	40Hz-125Hz ... 5dB 125Hz-10KHz ... 3dB 10KHz-15KHz ... 5dB
	SPECIAL Band einschieben	VR106	
	Normal Band einschieben	VR105	40Hz-125Hz ... 5dB 125Hz-10KHz ... 3dB 10KHz-14KHz ... 5dB

Réglages de sy l'enregistrement

Instruments: Générateur de signal, analyseur
 Conditions: Dolby NR ... OFF
 Niveau de l'enregistrement ... m

Réglage	Conditions
Niveau de la sortie de l'enregistrement/reproduction	Générateur de signal (4 ... LINE IN/LINE OU Relâcher le bouton de reproduction encore.
Contrôle de la déformations	Générateur de signal (4 ... LINE IN/LINE OU Analyseur H.D. ... LIN Relâcher le bouton de et reproduire encore.
	Si le facteur de la défor du courant de la polaris
Contrôle de réponse de fréquence	Insérer la bande META
	Insérer la bande SPECI
	Insérer la bande NORM

Block Diagram, Schéma synopti

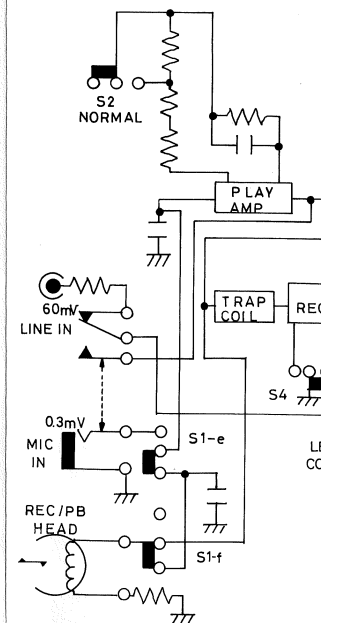

Réglages de système de l'enregistrement/reproduction

Instruments: Générateur de signal, analyseur H.D., et bande vierge
Conditions: Dolby NR ... OFF

Niveau de l'enregistrement ... maximum Reproduction, enregistrement, pause ... ON

Réglage	Conditions	Régler	Régler pour
Niveau de la sortie de l'enregistrement/reproduction	Générateur de signal (400 Hz 0dB) ... LINE IN/LINE OUT ... 450mV Relâcher le bouton de pause et reproduire encore.	VR102 (L.Ch) VR202 (R.Ch)	Différence de niveau de l'enregistrement et reproduction doit être dans ± 1 dB.
Contrôle de la déformations	Générateur de signal (400 Hz 0dB) ... LINE IN/LINE OUT ... 450mV Analyseur H.D. ... LINE OUT Relâcher le bouton de pause et reproduire encore.	Vérifier que la déformation est dans la plage donnée suivante. a. Bande métal ... sous 2% b. Special ... sous 4% c. Bande normale ... sous 2%	
	Si le facteur de la déformation excède les valeurs ci-dessus, vérifier le réglage du courant de la polarisation.		
Contrôle de réponse de fréquence	Insérer la bande METAL	VR103 (L.Ch) VR203 (R.Ch)	40Hz-125Hz ... 5dB 125Hz-10KHz ... 3dB 10KHz-15KHz ... 5dB.
	Insérer la bande SPECIAL	VR106	
	Insérer la bande NORMAL	VR105	40Hz-125Hz ... 5dB 125Hz-10KHz ... 3dB 10KHz-14KHz ... 5dB.

Block Diagram/Blockschaltbild/ Schéma synoptique

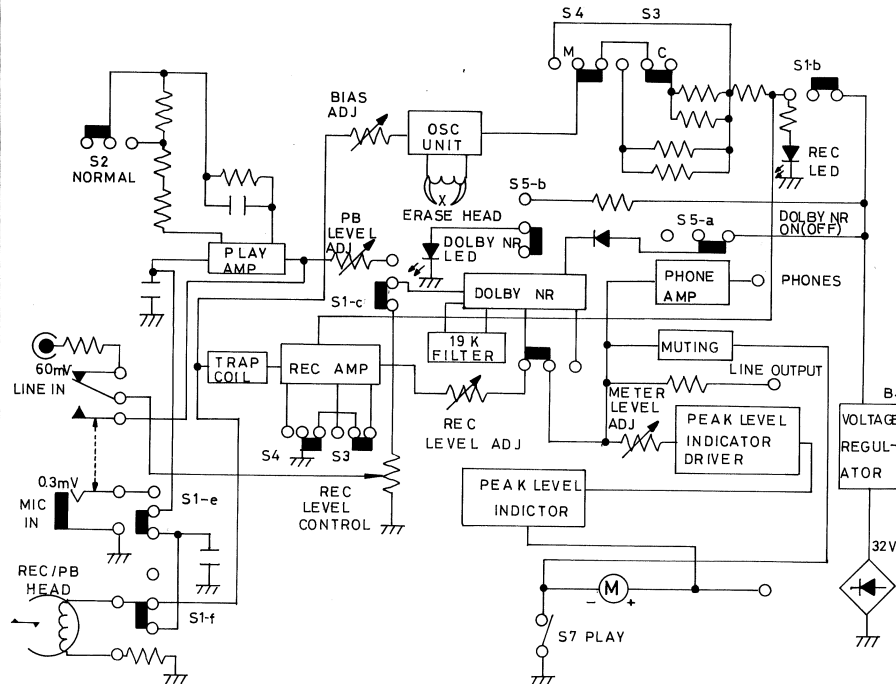

Repair Parts List/Reparaturteilliste/ Liste des pièces de rechange

Schematic Location	Parts No.	Description	Schematic Location	Parts No.	Description
TRANSISTORS, DIODES AND IC'S			VR107,207	0518-1-401-3K	3KB, REC Level Ind. Adj.
SWITCHES AND OTHERS			S1	0614TR-1205	Switch, Slide, REC/PB
Q101-103	0332SC1570-EF	2SC1570, MIC/REC Amp.	S2,3,4,5	0614TR-1563	Switch, Push 5-Key, NORMAL/SPECIAL/METAL/DOLBY NR
Q104,204	0332SD571-KL	2SD571 (K,L), Phono Amp.	S6	061C-3700	Switch, Power Supply (for UL, CSA)
Q105,205	032LC945-PK	LC945, for Mute	T001	022TT-148-GF-1	Power Transformer, (120 only)
Q091	0332SD600K-EF	2SD 600K (E,F), OSC		022TT-148-GF	Power Transformer, (Multi Type)
Q902	0332SD313-DE	2SD313 (E'D), Stabilizer	F901,902	036L250V0.5A	Fuse, 0.5A AC Circuit Protector (Long Size)
D101,201	0341N4148	1N4148, Reversal Prevention		036ASG3250V0.5A	Fuse, 0.5A AC Circuit Protector (Long Size UL)
D102	034C-3942	DOLBY NR and REC Level Ind. (G//GGGG)		036(S) F500mA	Fuse, 500mA, AC Circuit Protector (Mini Size "S" "D" mark)
D103-108	034C-3943	REC Level Ind. (GGRRRR/)		036M500mA	Fuse, 500mA, AC Circuit Protector (Mini Size)
D203-208	034C-3943	REC Level Ind. (GGRRRR/)			
D113	034C-3944	REC and REC Level Ind. (R//GGGG)			
D301,302	034UZ-3.6B	UA-3.6B, Reversal Prevention 3.6V/4W			
D303	0341N4148	1N4148, Reversal Prevention			
D901	034HZ22-1	WZ-210, Zener Regulator 21V $\frac{1}{2}$ W			
D902	034LN224RP-6	LN224RP, Power Ind.			
D903,904	034W-02	W-02, Regulator			
IC101,201	031LM1111B	LM111B, REC/PB Amp.			
IC102	031TA-7667P	TA-7667P, LED Driver			
IC202	031TA-7666P	TA-7666P, LED Driver			
COILS AND VARIABLE RESISTORS					
L101,201	021TRL-195	85KHz, Trap Coil			
L102,202	021TRL-164	Filter			
L103,203	021TRL-147	Peaking Coil			
L104,204	021TRL-153	Peaking Coil			
L105,205	021TRL-161	Peaking Coil			
L901	021TRL-168	OSC			
VR101,201	0518-1-401-50K	50KB, PB Level Adj.			
VR102,202	0518-1-401-20K	20KB, REC Level Adj.			
VR103,203	0518-1-401-100K	100KB, Bias Adj.			
VR104	0514TR-1505	50KAx2, REC Level Control			
VR105	0518-1-401-5K	5KB, NORMAL Bias Adj.			
VR106	0518-1-401-1K	1KB, SPECIAL Bias Adj.			

Schematic Diagram/Schaltungsschema/Diagramme de schématique

NOTE: PARTS CIRCUIT SUBJECT TO CHANGES FOR IMPROVEMENTS WITHOUT PRIOR NOTICE MODEL RD-820

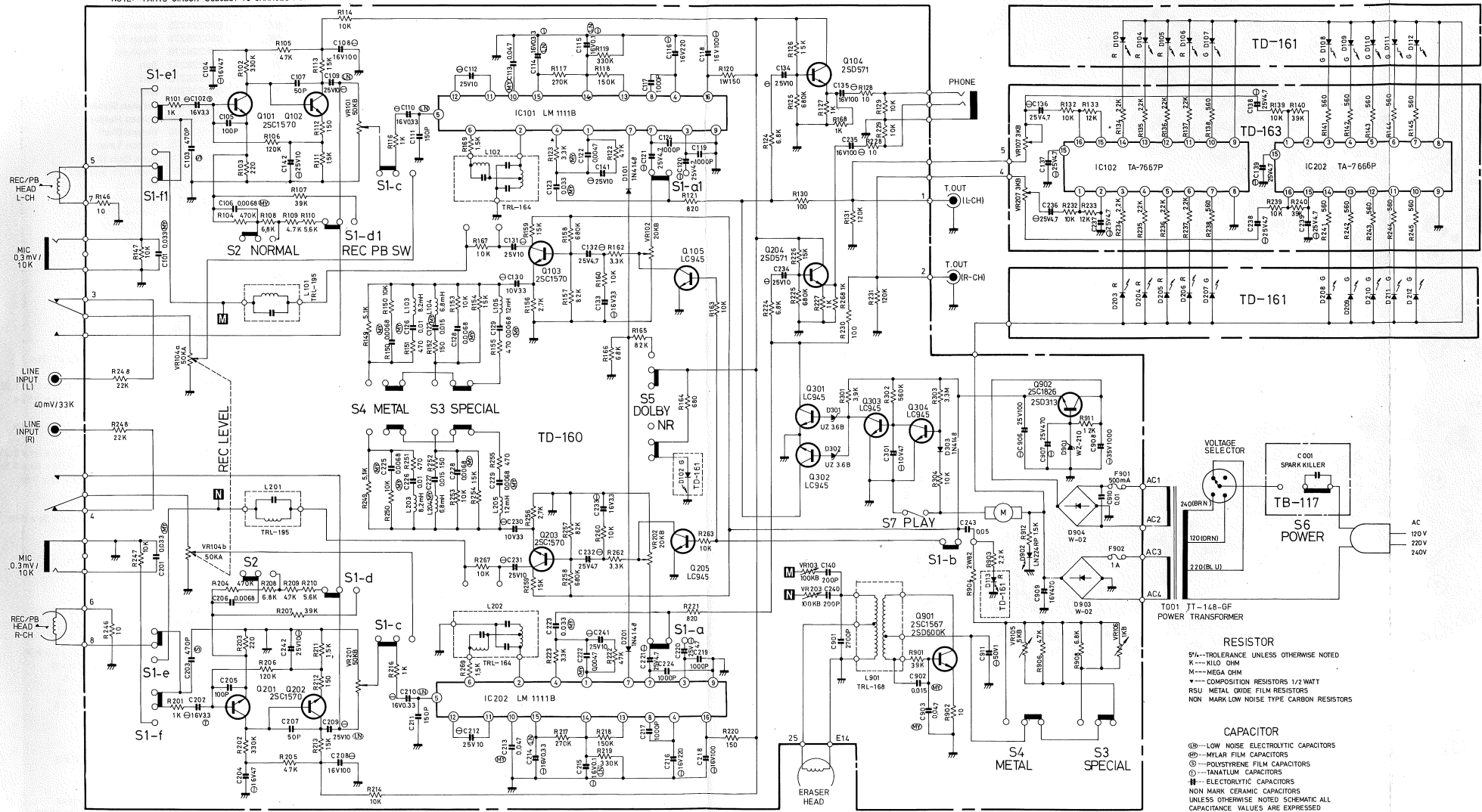

RESISTOR
 5%—TOLERANCE UNLESS OTHERWISE NOTED
 K—KILO OHM
 M—MEGA OHM
 *—COMPOSITION RESISTORS 1/2 WATT
 RSU—METAL OXIDE FILM RESISTORS
 NON—MARK LOW NOISE TYPE CARBON RESISTORS

CAPACITOR
 (B)—LOW NOISE ELECTROLYTIC CAPACITORS
 (M)—MYLAR FILM CAPACITORS
 (P)—POLYSTYRENE FILM CAPACITORS
 (T)—TANTALUM CAPACITORS
 (E)—ELECTROLYTIC CAPACITORS
 NON MARK—CERAMIC CAPACITORS
 UNLESS OTHERWISE NOTED SCHEMATIC ALL CAPACITANCE VALUES ARE EXPRESSED

Wiring Diagram/Drahtleitung Diagramm/Diagramme de connexion

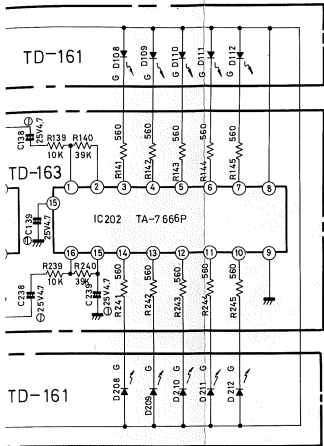

LM-1111 B			
1	INPUT 3.6V	9	GROUND 0V
2	INPUT 3.6V	10	DECOUPLING 35V
3	OUTPUT 3.6V	11	OUTPUT 3.6V
4	BIAS 3.6V	12	INPUT 1.5V
5	INPUT 3.6V	13	BIAS 1.5V
6	OUTPUT 3.6V	14	OUTPUT 8V
7	OUTPUT 3.6V	15	CONROL 8V
8	DECOUPLING 0V	16	VCC 8.4V

ITEM	SCHEMATIC	LOCATION(LAST)
REC PB AMP	R 168	C139
	R 268	C242
AUTO SHUT OFF	R 304	C301
POWER SUPPLY	R 912	C911
CHASSIS		C001

TOP VIEW

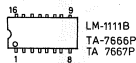

BOTTOM VIEW



SIDE VIEW

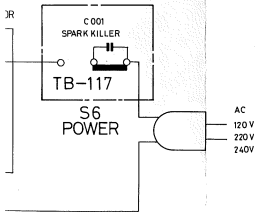
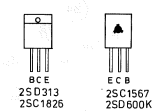

SISTOR
 ICE UNLESS OTHERWISE NOTED
 4
 M
 TION RESISTORS 1/2 WATT
 FNE FILM CAPACITORS
 4 CAPACITORS
 LYTIC CAPACITORS
 TRAMIC CAPACITORS
 WISE NOTED SCHEMATIC ALL
 VALUES ARE EXPRESSED

PACITOR
 SE ELECTROLYTIC CAPACITORS
 IM CAPACITORS
 FNE FILM CAPACITORS
 4 CAPACITORS
 LYTIC CAPACITORS
 TRAMIC CAPACITORS
 WISE NOTED SCHEMATIC ALL
 VALUES ARE EXPRESSED

REC/PB AMP / AUTO SHUT OFF POWER SUPPLY C.B.D.

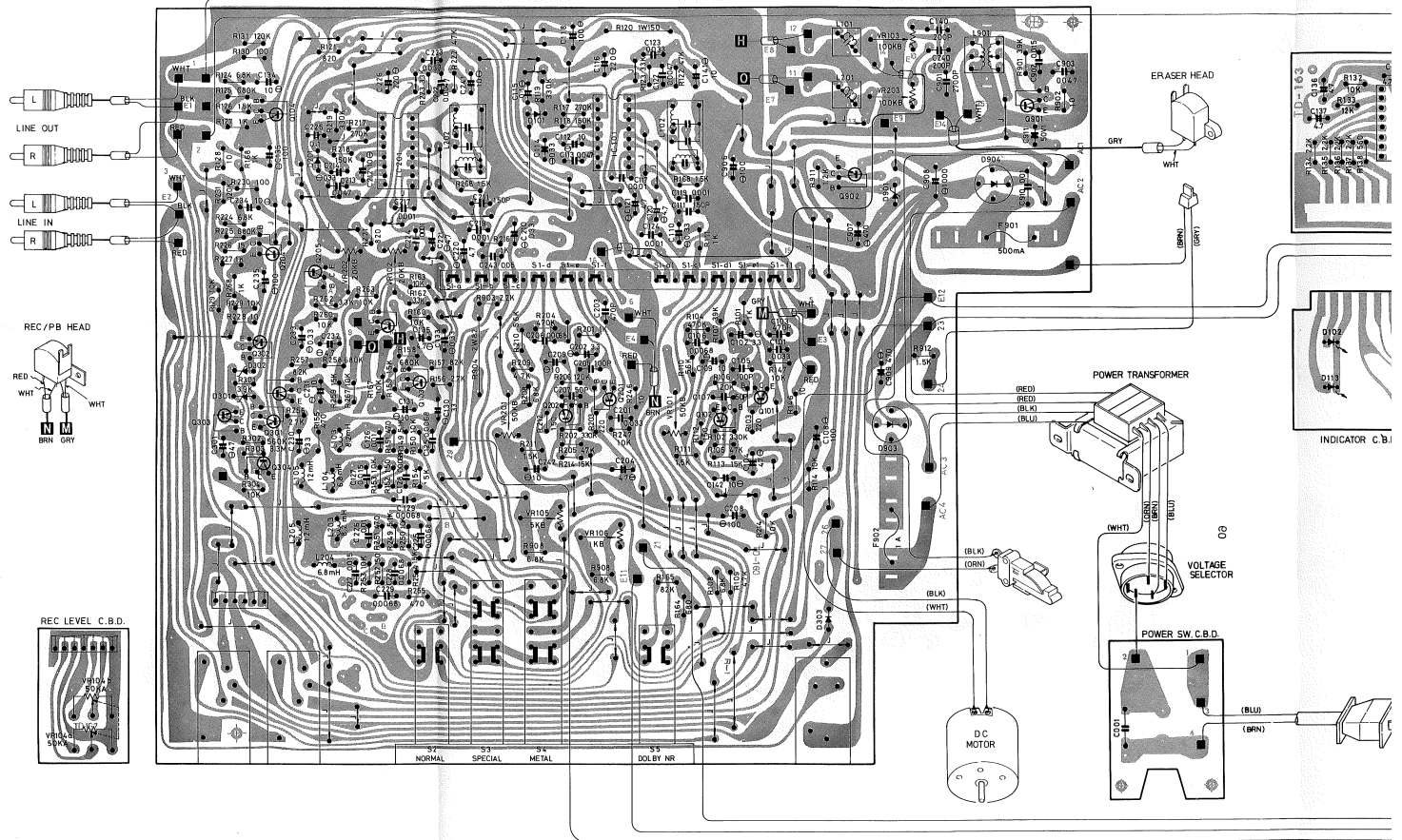

Wiring Diagram/Drahtleitung Diagramm/Diagramme de connexion

REC / PB AMP / AUTO SHUT OFF POWER SUPPLY C.B.D.

B	
9	GROUND 0V
0	DEC COUPLING 35V
1	OUTPUT 3.4V
12	INPUT 1.5V
13	BIAS 1.5V
14	OUTPUT 8V
15	CONTROL 8V
16	VCC 8.4V

SCHEMATIC TION(LAST)	
68	C139
68	C249
04	C301
12	C911
—	CO01

18
66P
67P

370

1 B
C1567
D600K

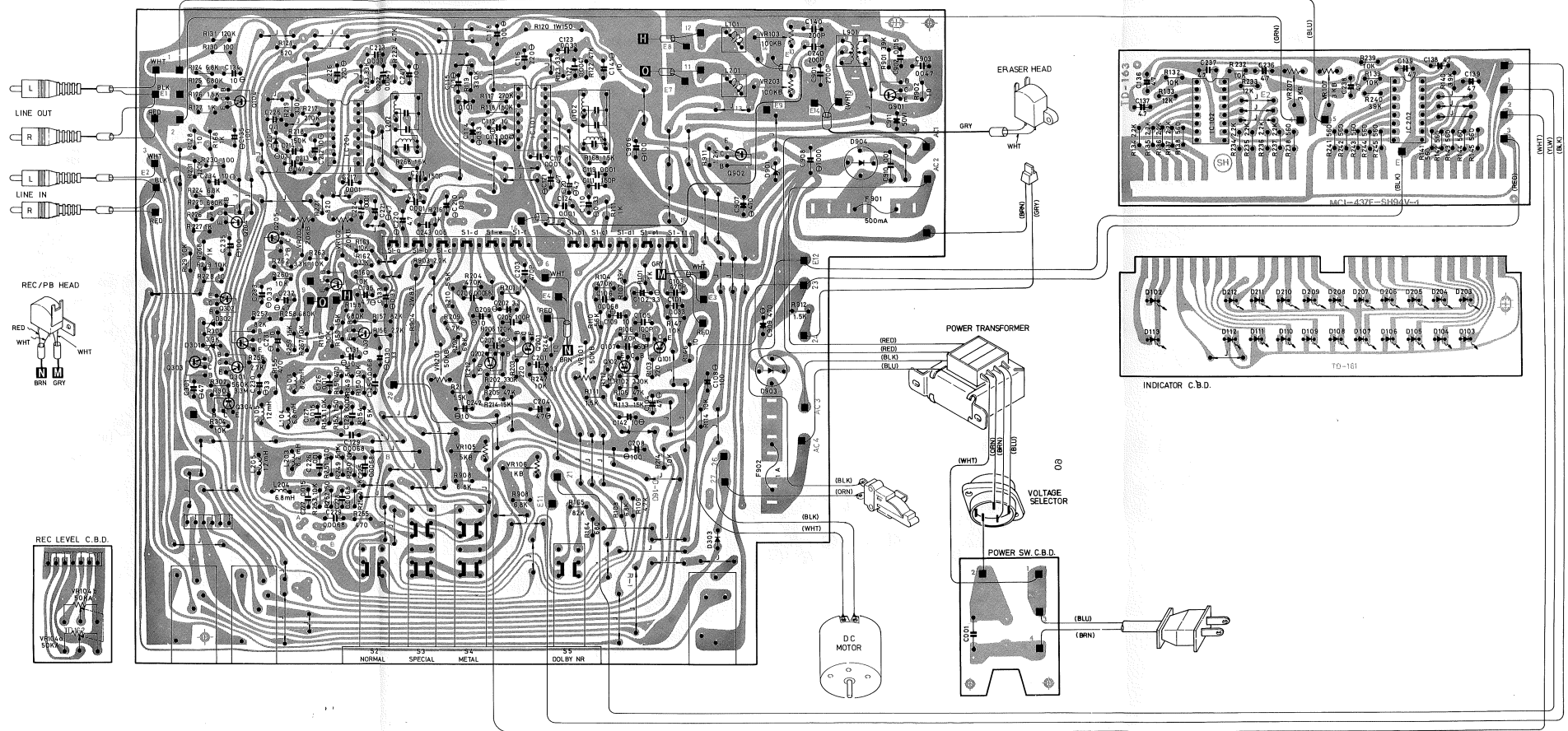

Disassembly Diagram / Illustration des Auseinanderbaus / Schéma de démontage (1 / 2)

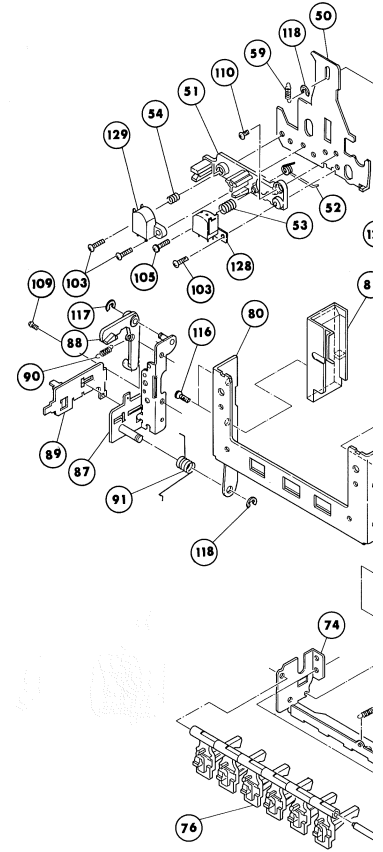
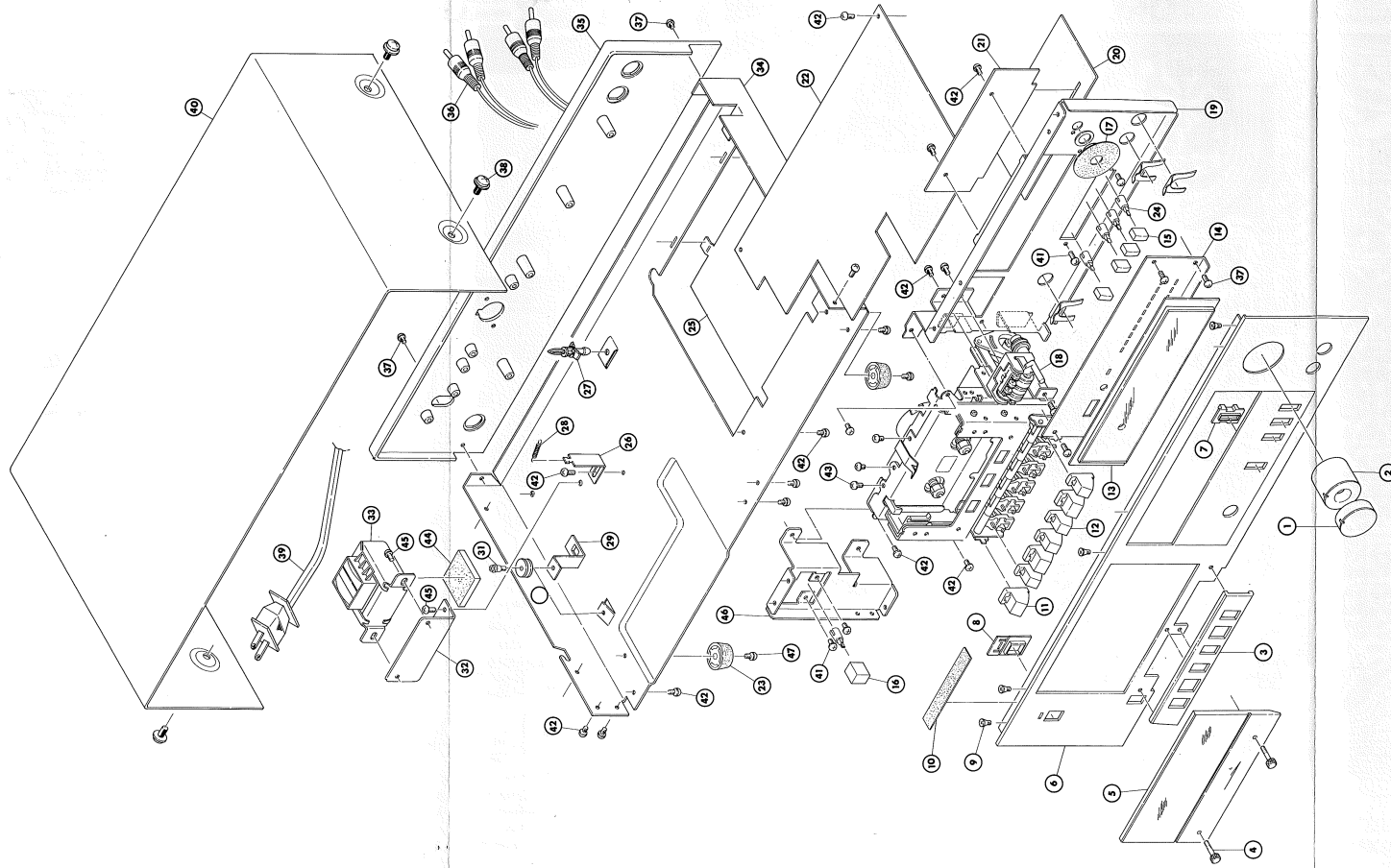

Key No.	Parts No.	Description
1	012C-3872-T	Knob, 30¢ for REC Level (WL)
2	012C-3873-T	Knob, 30¢ for REC Level (WR)
3	0192TWH-7A#1	Deck Button Ornamental Board
4	07141TXV-30	Screw, Ornamental Board
5	0143TWD-13	Acrylic Door Plate
6	0112TWD-1A#1	Front Panel
7	019C-3546-T	Push SW Connector Frame
8	0194TR-1946	Push SW Connector Frame
9	071SA3x6N	Screw, MF3x6Ni
10	0194TR-1087	Felt, Front Panel
11	0124TR-1545	Deck Push Button
12	0124TXV-16	Deck Push Button
13	0133TWD-6#4	Panel Window
14	015DB-173	LED Ornamental Plate
15	012C-3372#1	Push Button (DOLBY/NR/METAL/SPEC/NORM)
16	012C-3882	Push Button
17	0194TR-1083B#3	Felt, Knob (39¢)
18	0694TR-1511	Tape Counter
19	0132TWD-2B	Front Chassis (A)
20	501TD-163	PCB (TD-163)
21	501TD-161	PCB (TD-161)
22	501TD-160	PCB (TD-160)
23	0194TR-1257A	Plastic Foot
24	0194TR-1216	Push Button Connector
25	0133TXD-14	Bottom Cover
26	0134TXD-8A	REC String Support
27	019C-1195	Plastic PCB Support
28	019C-3490	REC Spring
29	0134TWD-9	REC String Support
30	0194TR-905A	Pulley
31	07141TR-1004	Pulley Screw
32	0134TXD-18	PT Support
33	022TT-148-GF-1	Power Transformer (120 only)
	022TT-148-GF	Power Transformer (Multi Type)
34	0132TWD-4	Main Chassis
35	0152TWD-14#1	Plastic Rear Board
36	07341TR-1135B#1	Pin Jack Shield Cord
37	071BZTP3x8B	Screw, TPV3x8BK
38	071NBW4x6N	Screw, MPW4x6Ni
39	0724TR-670#1	AC Power Cord (U.C.)
	0724TR-670	AC Power Cord (H.E)
40	072C-2504	AC Power Cord (K)
	072C-3763	AC Power Cord (G)
41	0142TWE-5#3	Upper Cover
42	071NB3x6N	Screw, MV3x6Ni
43	071BZTP3x6Z	Screw, TPV3x6Ni
44	071NBTP2.6x4Z	Screw, TPV2.6x4Ni
	0194TR-1144A	PT, Rubber Spacer
45	071NB4x6N	Screw, MP4x6Ni
46	0134TWD-3B	Front Chassis (B)
47	071BZTP3x8Z	Screw, TPV3x8Ni

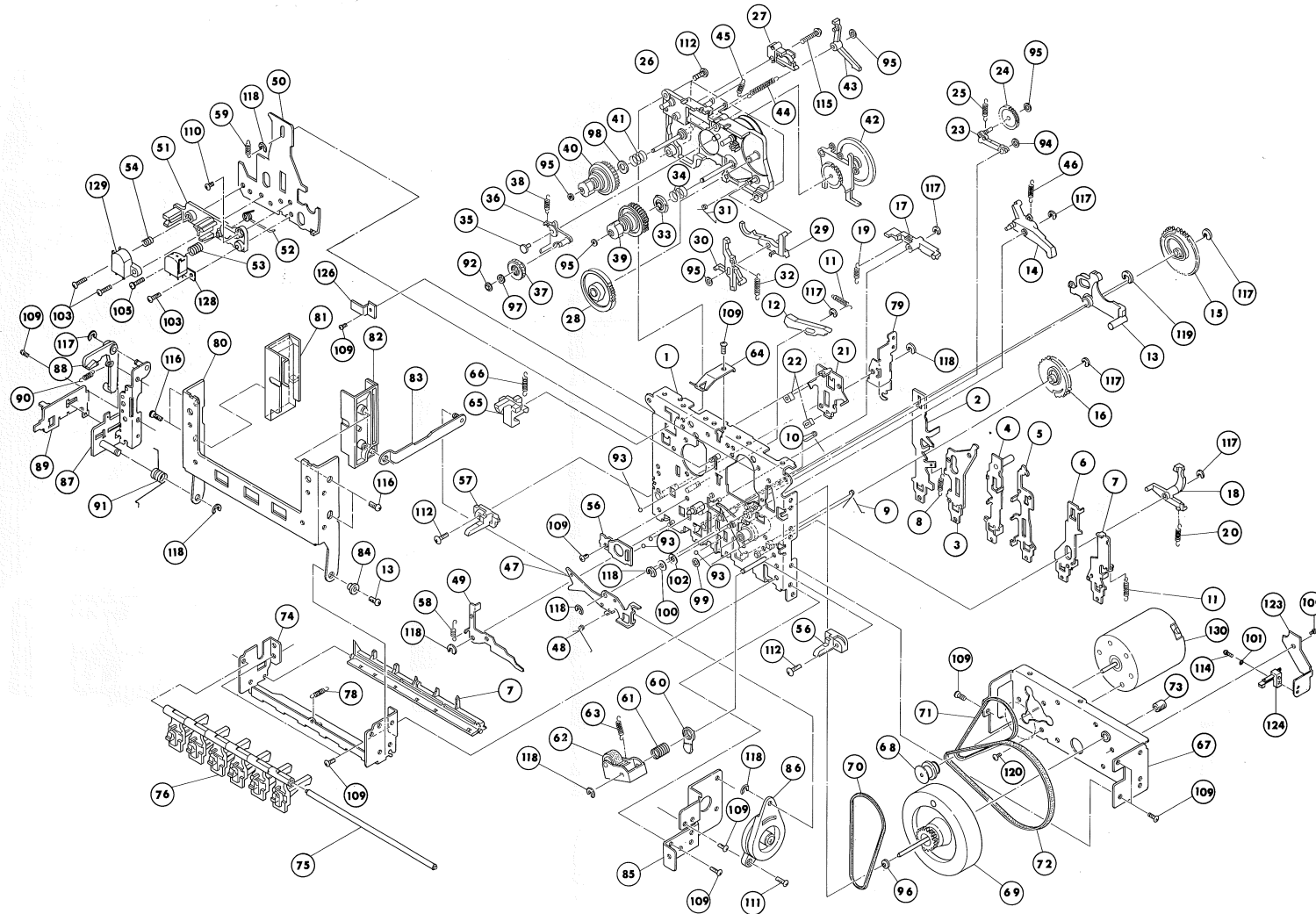

Key No.	Parts No.	Des
1	090221191	Che
2	090221192	Rec
3	090221193	Play
4	090221194	Rev
5	090221195	FF
6	090221196	Sto
7	090221197	Pau
8	090226241	Rec
9	090226242	Lev
10	090226243	Lev
11	090226244	Pau
12	090221198	Rec
13	090221199	Shi
14	090221200	Shi
15	090226244	Gea
16	090226245	Gea
17	090221201	Gea
18	090221202	Gea
19	090221203	Shi
20	090221204	Loc
21	090221203	Bra
22	090226249	Bra
23	090221204	FF
24	090226250	FF
25	090226251	FF
26	090221205	Rec
27	090226252	Qui
28	090226253	Aut
29	090221206	Sen
30	090221207	Aut
31	090226254	Sen
32	090226255	Aut
33	090221208	Aut
34	090226256	Ten
35	090226257	Bus
36	090221209	Play
37	090226258	Play
38	090226259	Play
39	090221210	T R
40	090221211	S R
41	090226260	Bac
42	090221212	FR
43	090221213	Rev
44	090226261	FR
45	090226262	FR
46	090226263	Shii
47	090221214	Aut
48	090226264	Aut
49	090221215	FR
50	090221216	Hea
51	090221217	Hea
52	090226265	Hea
53	090226266	Hea
54	090226267	Hea
55	090226268	Hea
56	090221218	Cas
57	090221219	Cas
58	090226269	FR
59	090226270	Bra
60	090221220	Pau
61	090226271	Pau
62	090221221	P. F
63	090226272	P. F
64	090226273	Paci
65	090221222	Rec
66	090226274	Rec

Disassembly Diagram / Illustration des Auseinanderbaus / Schéma de démontage (2/2)

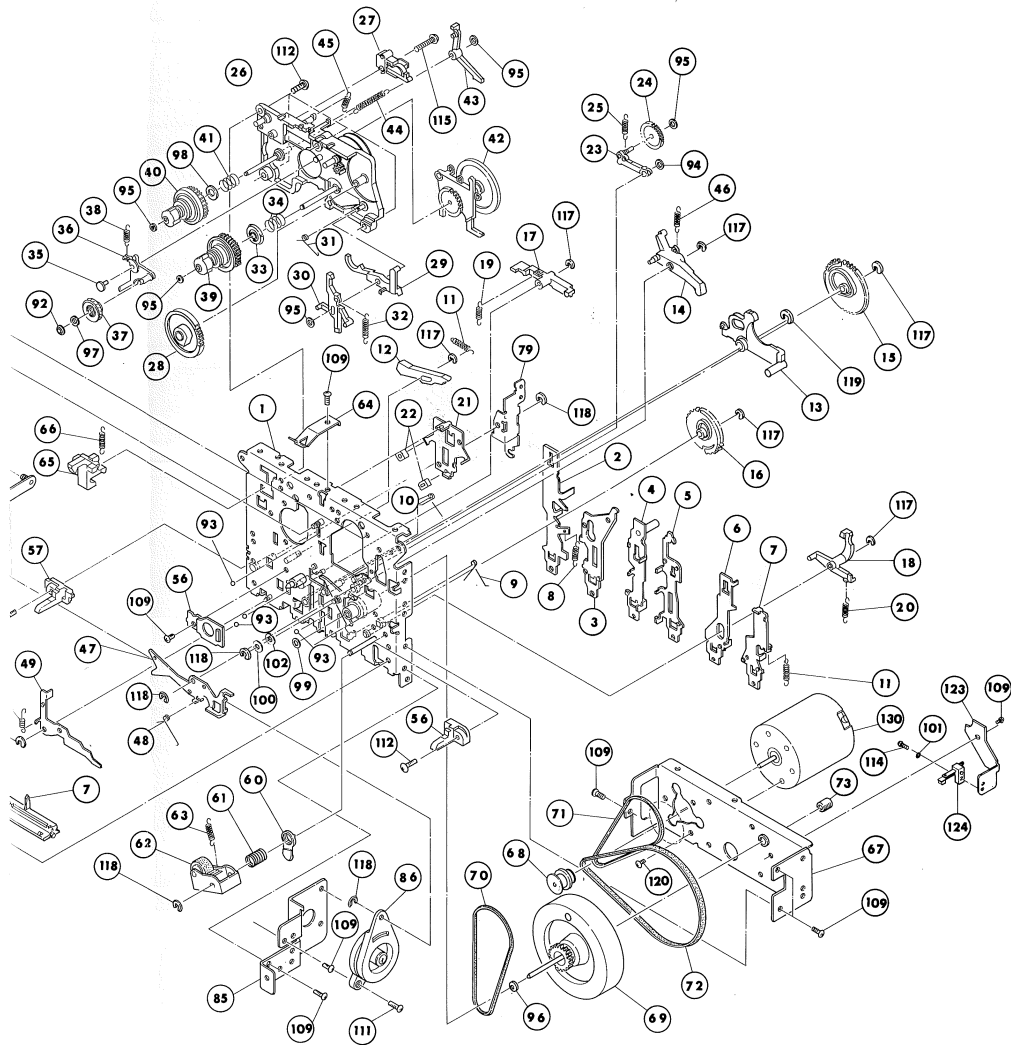

Key No.	Parts No.	Description	Key No.	Parts No.	Description
1	090221191	Chassis Assy	67	090221223	Motor Bracker (D)
2	090221192	Rec Lever	68	090226275	Motor Pulley (C)
3	090221193	Play Lever	69	090226276	Flywheel
4	090221194	Rew Lever Assy	70	090226277	Belt
5	090221195	FF Lever	71	090226278	Belt
6	090221196	Stop Lever	72	090226279	Belt
7	090221197	Pause Lever Assy	73	090227202	Capstan Screw
8	090226241	Rec Lever Spring	74	090221225	Button Holder
9	090226242	Lever Spring (B)	75	090226280	Button Shaft
10	090226243	Lever Spring (C)	76	090221225	Button Lever
11	090226244	Pause Lever Spring	77	090221226	Lock Cam (F)
12	090221198	Rec Lever (B)	78	090226281	Lock Cam Spring
13	090221199	Shift Arm (A)	79	090221227	Rec Arm
14	090221200	Shift Arm (B)	80	090221228	Cassette Case
15	090226244	Gear (A)	81	090221229	Cassette Pocket (L)
16	090226245	Gear (B)	82	090221230	Cassette Pocket (R)
17	090221201	Gear Lock Arm (A)	83	090221231	Damper Link Assy
18	090221202	Gear Lock Arm (B)	84	090227236	Case Collar
19	090221203	Shift Arm (A) Spring	85	090221232	Damper Bracket
20	090221204	Lock Arm (B) Spring	86	090221233	Damper Assy
21	090221203	Brake Lever	87	090221234	Case Bracket Assy
22	090226249	Brake Shoe	88	090221235	Case Lock Arm
23	090221204	FF Idler Arm Assy	89	090221236	Eject Lever
24	090226250	FF Gear	90	090226158	Pause Lever Spring
25	090226251	FF Gear Spring	91	090226282	Case Spring
26	090221205	Reel Base Assy	92	770911197	Push Nut 1.9φ x 6φ x 0.25t
27	090226252	Quick Action Switch	93	651010113	Steel Ball 2φ
28	090226253	Auto Gear	94	770500109	Polyslider Washer 1.2φ x 5φ x 0.25t
29	090221206	Sensor Arm	95	770500110	Polyslider Washer 1.7φ x 3.5φ x 0.25t
30	090221207	Auto Arm	96	770500087	Polyslider Washer 2.6φ x 4.7φ x 0.25t
31	090226254	Sensor Arm Spring	97	770500111	Polyslider Washer 3.2φ x 6φ x 0.25t
32	090226255	Auto Arm Spring	98	770500112	Polyslider Washer 4.7φ x 9φ x 0.5t
33	090221208	Auto Clutch Assy	99	770500056	Nylon Washer 24φ x 5φ x 0.5t
34	090226256	Tension Spring	100	090227237	Nylon Washer
35	090226257	Bush	101	090227207	Plain Washer (S) 2φ
36	090221209	Play Arm	102	770500003	Plain Washer (L) 32φ x 8φ x 0.5t
37	090226258	Play Idler	103	090227238	Binding Screw
38	090226259	Play Arm Spring	104		
39	090221210	T Reel Assy	105	090227239	Washer Head Screw
40	090221211	S Reel Assy	106		
41	090226260	Back Tension Spring	107		
42	090221212	FR Pulley Arm Assy	108		
43	090221213	Rew Arm	109	763202604	Tap Tite Screw 2.6 x 4
44	090226261	FR Pulley Arm SP. (A)	110	763222604	Tap Tite Screw (BL) 2.6 x 4
45	090226262	FR Pulley Arm SP. (B)	111	763202606	Tap Tite Screw 2.6 x 6
46	090226263	Shift Arm (B) Spring	112	763222608	Tap Tite Screw (BL) 2.6 x 8
47	090221214	Auto Lock Arm	113	763202608	Tap Tite Screw 2.6 x 8
48	090226264	Auto Lock Arm Spring	114	723202006	Tapping Screw 2 x 6
49	090221215	FR Lock Arm (N)	115	723202012	Tapping Screw 2 x 12
50	090221216	Head Chassis	116	723202606	Tapping Screw 2.6 x 6
51	090221217	Head Base	117	770500005	E Ring 2φ
52	090226265	Head Base Spring	118	770500027	E Ring 2.5φ
53	090226266	Head Spring	119	770500040	E Ring 4φ
54	090226267	Head Spring	120	703202603	Pan Pan Screw 2.6 x 3
55	090226268	Head Chassis Spring	121		
56	090221218	Cassette Guide (R)	122		
57	090221219	Cassette Guide (L)	123	090221237	Pause Switch Bracket
58	090226269	FR Lock Arm Spring	124	615212288	Leaf Switch LSA-1123-29
59	090226270	Brake Spring	125		
60	090221220	Pause Cam	126	090221238	Sub Bracket (C)
61	090226271	Pause Cam Spring	127		
62	090221221	P. Roller Arm Assy	128	241001125	RP Head
63	090226272	P. Roller Spring	129	241001126	E Head
64	090226273	Pack Spring	130	260101130	Motor
65	090221222	Rec Sensor			
66	090226274	Rec Sensor Spring			