



Technical Manual

STEREO ACTIVE CONTROLLER RHA10 REMOTE HANDUNIT RHR10AT

Table of Contents

Specification1
 Parts List2.3
 Wiring Diagram4.5
 Schematic Diagram RHR10AT6
 PCB Assembly7.8
 Schematic Diagram RHA109.10

Specifications

- Total Harmonic Distortion
 (20 Hz — 20 kHz,
 rated output) No more than 0.004%
 (20 Hz — 20 kHz,
 10 V output)..... No more than 0.004%
- Intermodulation
 Distortion
 (60 Hz : 7 kHz=4 : 1) .. No more than 0.004%
- Input (1-5) Sensitivity/
 Impedance..... 140 mV/13 kohms
- REC OUT Impedance .. 100 ohms
- Output Sensitivity/
 Impedance..... 0.775 V/100 ohms
- Frequency response..... 4 Hz — 100 kHz ± 0.1 / ± 0.3 dB
- Signal-to-Noise Ratio
 (IHF A Network)..... 100 dB
- Power Supply..... AC 120 V/60 Hz, 230 V/50 Hz,
 240 V/50 Hz
- Power Consumption 12 W (2.4 W during standby)
- Dimensions..... 470 (W) x 76 (H) x 332 (D) mm
 (18 1/2" x 3" x 13 1/16")
- Weight 7.7 kg/16.90 lbs

- Specifications and design subject to possible modification without notice.

Serial No. Beginning

SYMBOL	PARTS NO.	DESCRIPTION
016E-1192-00T PCB ASSEMBLY		
C401, 402	041 25BGF100M	CAP, ELEC. 25V100UF
C403, 404	041 25BGF100M	CAP, ELEC. 25V100UF
C405, 406	044 MKT1818-410/015	CAP, M. P 100V104K
C407, 408	044 MKT1818-410/015	CAP, M. P 100V104K
C501, 502	041 25BGF47M	CAP, ELEC. 25V47UF
C503, 504	044 FKP2-100V101	CAP, P. P 100V100PF
C505, 506	041 50BGF010M	CAP, ELEC. 50V10UF
C507, 508	041 25BGF47M	CAP, ELEC. 25V47UF
C515, 516	041 35BGF100M	CAP, ELEC. 35V100UF
C517, 518	041 35BGF100M	CAP, ELEC. 35V100UF
C901, 902	041 LGS1H472MHS	CAP, ELEC. 50V4700UF
C903, 904	041 LGS1H472MHS	CAP, ELEC. 50V4700UF
C905, 906	041 35BGF470M	CAP, ELEC. 35V470UF
C907, 908	041 35BGF470M	CAP, ELEC. 35V470UF
C909, 910	041 35BGF100M	CAP, ELEC. 35V100UF
C911, 912	041 35BGF100M	CAP, ELEC. 35V100UF
C915, 916	041 35BGF470M	CAP, ELEC. 35V470UF
C917, 918	041 25BGF100M	CAP, ELEC. 25V100UF
C922	043 250VZF103	CAP, CERA. 250V0. 01UF
C923	043 250VZF103	CAP, CERA. 250V0. 01UF
C924	043 250VZF103	CAP, CERA. 250V0. 01UF
C925, 926	044 MKT1818-410/015	CAP, M. P 100V0. 1UF
C927, 928	044 MKT1818-410/015	CAP, M. P 100V0. 1UF
C001	043 250VZF103	CAP, CERA 250V0. 01UF
C002	043 250VZF103	CAP, CERA 250V0. 01UF
D501, 502	034 1N4148	DIODE
D503, 504	034 1N4148	DIODE
D505, 506	034 1N4148	DIODE
D507, 508	034 1N4148	DIODE
D509, 510	034 MA27W-A	DIODE
D701	034 1N4148	DIODE
D713	034 1N4148	DIODE
D714	034 1N4148	DIODE
D715	034 1N4148	DIODE
D901, 902	034 BR84	DIODE
D905	034 RD24EB	DIODE
D907	034 RD24EB	DIODE
D908	034 RD18EB	DIODE
D909	034 RD18EB	DIODE
D910	034 E562	DIODE
D912	034 E562	DIODE
IC401, 402	031 AD712JN	IC
Q501, 502	033 2SC2362K-FG	TRANSISTOR
Q503, 504	033 2SC2362K-FG	TRANSISTOR
Q505, 506	033 2SA1016K-FG	TRANSISTOR
Q507, 508	033 2SA1016K-FG	TRANSISTOR
Q509, 510	033 2SA1016K-FG	TRANSISTOR
Q511, 512	033 2SC2362K-FG	TRANSISTOR
Q513, 514	033 2SA1016K-FG	TRANSISTOR
Q515, 516	033 2SC2362K-FG	TRANSISTOR

SYMBOL	PARTS NO.	DESCRIPTION
Q517, 518	033 2SC2682-P	TRANSISTOR
Q519, 520	033 2SA1142-P	TRANSISTOR
Q701	032 2SC536K-FG	TRANSISTOR
Q702	032 2SC536K-FG	TRANSISTOR
Q710	032 2SC536K-FG	TRANSISTOR
Q711	032 2SC536K-FG	TRANSISTOR
Q901, 902	033 2SB631K-EF	TRANSISTOR
Q903, 904	033 2SD600K-EF	TRANSISTOR
Q905, 906	033 2SC536K-EF	TRANSISTOR
Q907, 908	033 2SA608K-FG	TRANSISTOR
Q909	033 2SD600K-EF	TRANSISTOR
Q910	033 2SB631K-EF	TRANSISTOR
R201, 202	054 MK23K32FECZ	R, METAL 1% 3.32K
R203, 204	054 MK23K32FECZ	R, METAL 1% 3.32K
R205, 206	054 MK23K32FECZ	R, METAL 1% 3.32K
R207, 208	054 MK23K32FECZ	R, METAL 1% 3.32K
R209, 210	054 MK23K32FECZ	R, METAL 1% 3.32K
R401, 402	054 MK2221KFECZ	R, METAL 1% 221K
R403, 404	054 MK2221KFECZ	R, METAL 1% 221K
R405, 406	054 MK2001KFECZ	R, METAL 1% 1K
R407, 408	054 MK2001KFECZ	R, METAL 1% 1K
R409, 410	054 MK2100KFECZ	R, METAL 1% 100K
R411, 412	054 MK2100KFECZ	R, METAL 1% 100K
R413, 414	054 MK2100RFECZ	R, METAL 1% 100R
R415, 416	054 MK2100RFECZ	R, METAL 1% 100R
R501, 502	054 VSH101	R, METAL 100R
R503, 504	054 VSH473	R, METAL 47K
R505, 506	054 MK21K21FECZ	R, METAL 1% 1.21K
R507, 508	054 MK21K21FECZ	R, METAL 1% 1.21K
R509, 510	054 MK21K21FECZ	R, METAL 1% 1.21K
R511, 512	054 MK21K21FECZ	R, METAL 1% 1.21K
R513, 514	054 MK2274RFECZ	R, METAL 1% 274R
R515, 516	054 MK2274RFECZ	R, METAL 1% 274R
R517, 518	054 MK222K1FECZ	R, METAL 1% 22.1K
R519, 520	054 MK2475RFECZ	R, METAL 1% 475R
R521, 522	054 MK2475RFECZ	R, METAL 1% 475R
R523, 524	054 MK2221RFECZ	R, METAL 1% 221R
R525, 526	054 VSH472	R, METAL 4.7K
R527, 528	054 VSH223	R, METAL 22K
R529, 530	054 VSH100	R, METAL 10R
R531, 532	054 VSH100	R, METAL 10R
R533, 534	054 VSH473	R, METAL 47K
R535, 536	054 VSH101	R, METAL 100R
R701	054 MK2100KFECZ	R, METAL 1% 100K
R702	054 MK247K5FECZ	R, METAL 1% 47.5K
R703	054 MK2100kFECZ	R, METAL 1% 100k
R704	054 MK2475RFECZ	R, METAL 1% 475R
R710	054 MK2221KFECZ	R, METAL 1% 221k
R711	054 MK25K62FECZ	R, METAL 1% 5.62K
R712	054 MK21k82FECZ	R, METAL 1% 1.82K

SYMBOL	PARTS NO.	DESCRIPTION
R713	054 MK25K62FECZ	R, METAL 1% 5. 62K
R714	054 RSS1X-180F	R, METAL 1W 180R
R715	054 MK2221KFECZ	R, METAL 1% 221K
R904	054 MK21K21FECZ	R, METAL 1% 1. 21k
R905	054 MK21K21FECZ	R, METAL 1% 1. 21k
RY701	063 RY24W-KJ	RELAY
RY710	063 DH24D2-0	RELAY
SW1	062 C-4407A01	INPUT SELECTOR SWITCH
SW2	062 C-4407A02	REC OUT SELECTOR SWITCH
SW3	062 4TR-2908	REC OFF SWITCH
VR501	151 C-4410A02	VR 20K WITH MOTOR
<u>016X-1184-01T PCB ASSEMBLY</u>		
C721	041 U16V220	CAP, ELEC. 16V220UF
C722	043 50VZF103	CAP, CERA 250V0. 01UF
C951	041 U35V470	CAP, ELEC. 35V470UF
C952	041 U35V100	CAP, ELEC. 35V100UF
C953	041 U16V100	CAP, ELEC. 16V100UF
C954	044 DE7150F472M	SPARK KILLER
C955	043 250VZF103	CAP, CERA 250V0. 01UF
D721	034 RD12EB	DIODE
D722	034 RD5. 6EB	DIODE
D950	034 W02	DIODE
D951	034 1N4148	DIODE
F905	036 (S)T1A	FUSE 5ST1
	036 (U)F2. 5A	FUSE 5MF2. 5
IC720	031 LB1645N	IC
IC951	031 LM7806	IC
MOV1	034 TNR9G391K	METAL OXIDE VARISTOR
MOV2	034 TNR9G221K	METAL OXIDE VARISTOR
Q720	032 2SD863-EF	TRANSISTOR
Q951	032 2SC536-FG	TRANSISTOR
Q952	032 2SD863-EF	TRANSISTOR
R720	054 RSS1X-68F	R, METAL 1W 68R
R721	054 MK23K32FECZ	R, METAL 1% 3. 32K
R722	054 MK2010RFECZ	R, METAL 1% 10R
R951	054 RSS1X-100F	R, METAL 1W 100R
R952	054 MK222K1FECZ	R, METAL 1% 22. 1K
R953	054 MK2825RFECZ	R, METAL 1% 825R
R954	054 MK2010KFECZ	R, METAL 1% 10K
R955	054 ERQ14AJ2R2P	R, FUSE 5% 2. 2R
RY950	063 VFB24HU	RELAY
S731	061 4TR-2386#1	1 KEY PUSH SWITCH
<u>X-1184-02T PCB ASSEMBLY</u>		
C730	041 U10V47	CAP, ELEC. 16V47UF
C731	041 U16V100	CAP, ELEC. 16V100UF
C732	044 MKT1818-410/015	CAP, M. P 100V0. 1UF
C733	044 MKT1818-410/015	CAP, M. P 100V0. 1UF
C734	043 50VYB221	CAP, CERA 50V220pF
C735	043 50VYB221	CAP, CERA 50V220pF

SYMBOL	PARTS NO.	DESCRIPTION
C736	041 U25V10	CAP, ELEC. 25V10UF
D731	034 1N4148	DIODE
IC731	031 LC6522C-3433	IC
IC732	031 SBX1610-02	IC
Q731	032 2SC536K-FG	TRANSISTOR
R730	054 MK2100RFECZ	R, METAL 1% 100R
R731	054 MK247K5FECZ	R, METAL 1% 47. 5K
R732	054 MK247K5FECZ	R, METAL 1% 47. 5K
R733	054 MK247K5FECZ	R, METAL 1% 47. 5K
R734	054 MK247K5FECZ	R, METAL 1% 47. 5K
R735	054 MK247K5FECZ	R, METAL 1% 47. 5K
R736	054 MK247K5FECZ	R, METAL 1% 47. 5K
X731	023 CSB800J500	CERAMIC FILTER
<u>X-1184-03T PCB ASSEMBLY</u>		
D771	034 LTL2201A	LED
<u>OTHERS</u>		
011	PZ2-01A00	FRONT PANEL
012	PK4-13A00	KNOB 23 φ
012	PK4-14A00	KNOB 33 φ (WF)
012	PK4-15C00	KNOB 33 φ (WR)
012	PK4-16A00	KNOB PUSH 15X15
014	PK3-04B00T	BOTTOM BOARD
014	PK3-01A00	UPPER BOARD
014	PK3-24A00	WOOD SIDE BOARD
015	TRP-620	REAR CHASSIS
019	PK4-07A00T	METAL FOOT
022	T-1041S03	POWER TRANSFORMER
069	C-4459A00	AC OUTLET
069	4TR-2786	AC INLET
069	PK4-25A00T	EARTH TERMINAL
072	C-4392A01	AC CORD for USA, CANADA
072	C-4393A01	AC CORD for EUROPA
072	C-4393A02	AC CORD for UK
072	C-4423A01	AC CORD for AUSTRALIA
081	PZ4-11A00	INSIDE CARTON
RHR-10AT		REMOTE HANDSET
<u>E-1193 PCB ASSEMBLY</u>		
IC1	031 LC7461M-8100	IC
D1	034 SE313	LED
Q1	032 2SC2274K-EF	TRANSISTOR
X1	023 CSB455EB	CERAMIC FILTER
C1	034 50VSL101	CAP, CERA 50V100pF
C2	034 50VSL101	CAP, CERA 50V100pF
C3	041 U16V47	CAP, ELEC. 50V47UF
<u>OTHERS</u>		
011	PZ3-16A00T	FRONT PANEL (METAL)
019	PZ3-17A00T	PANEL (PLASTIC)
014	PZ3-26A00T	BOTTOM BOARD
014	PZ4-25A00T	SENSOR WINDOW
019	PZ3-22A00T	RUBBER BUTTON
019	PZ4-27A00T	BATTERY COVER

Wiring Diagram

RHA10

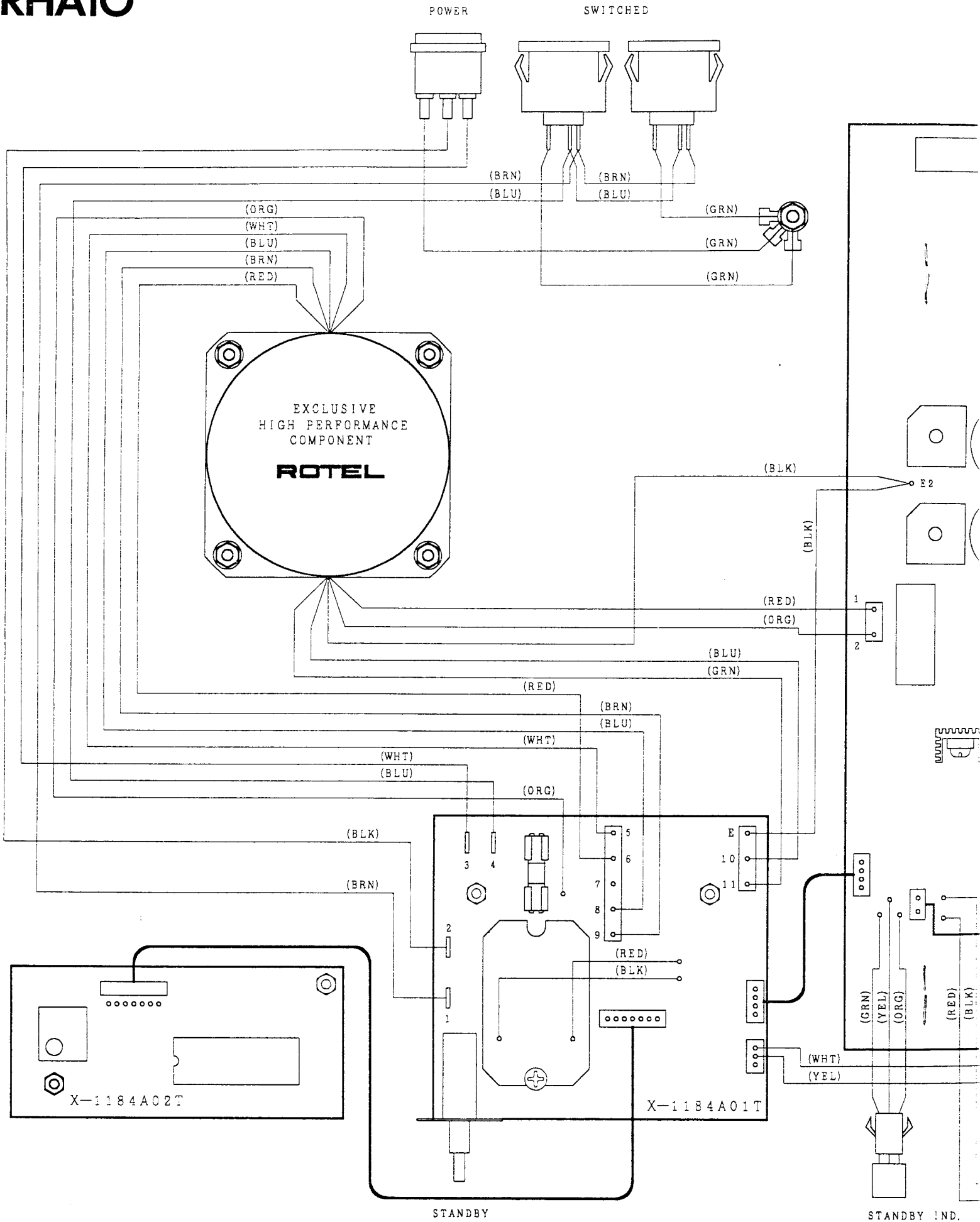

OUTPUT

5

4

3

2

1

2

1

OUT

IN

OUT

IN

3

2

1

016E-1192A00T

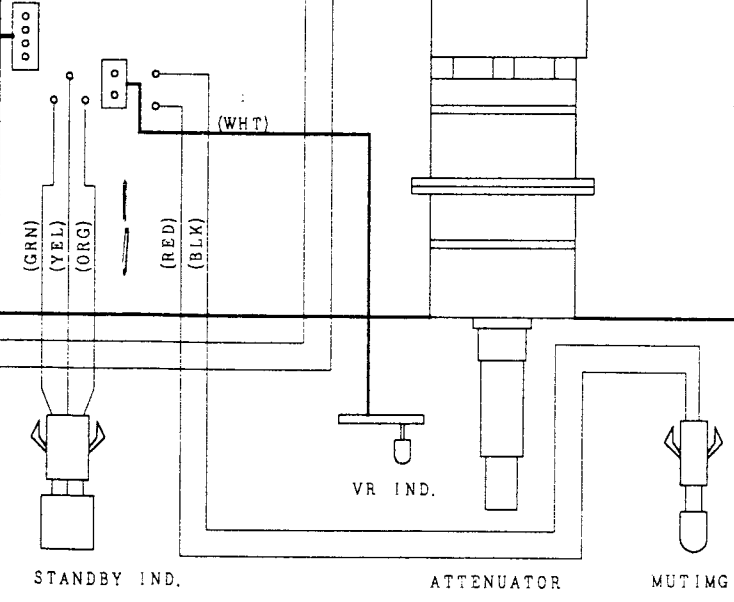
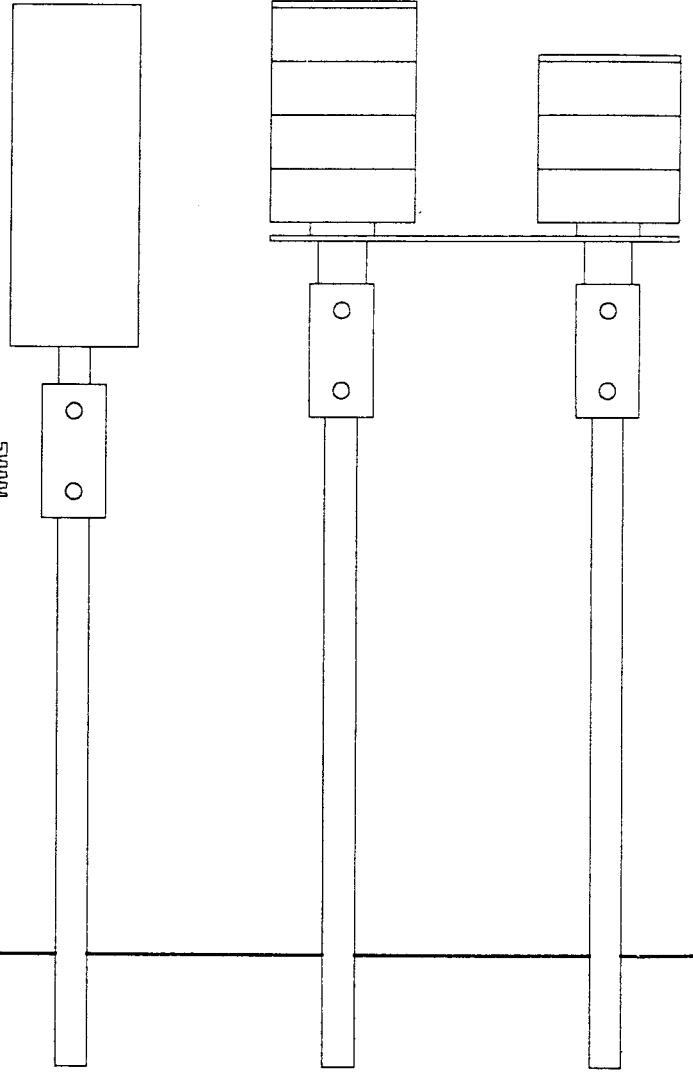
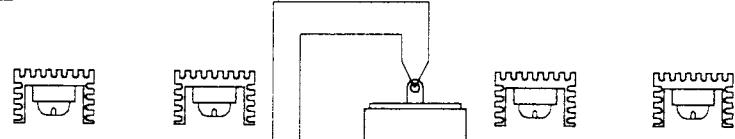
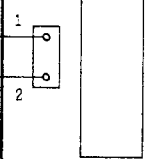
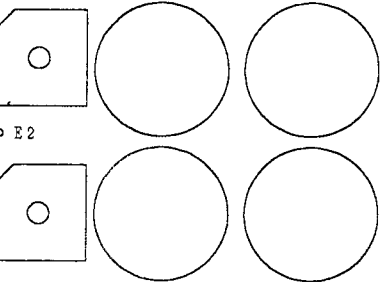
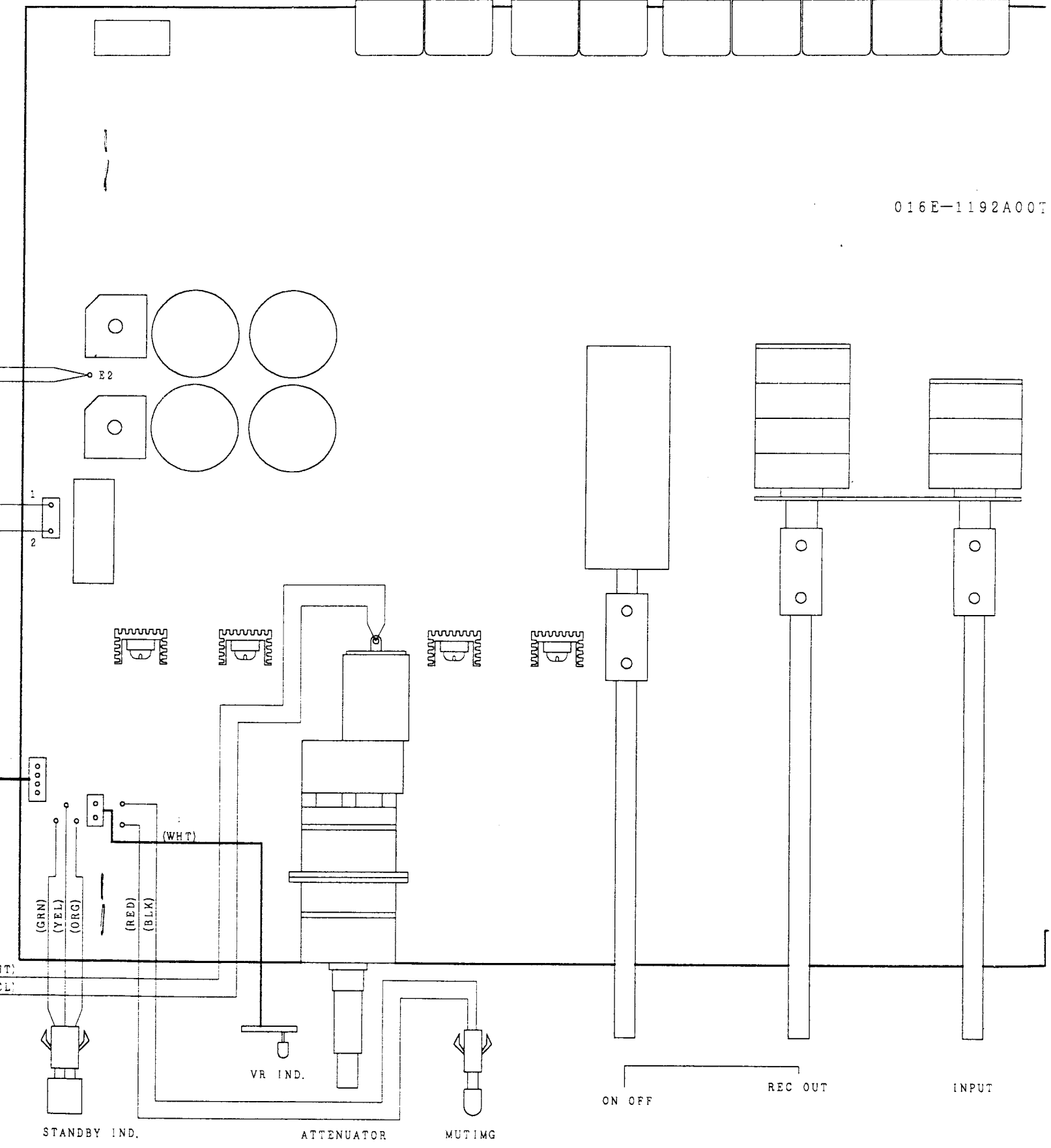

Schematic Diagram RHR10AT

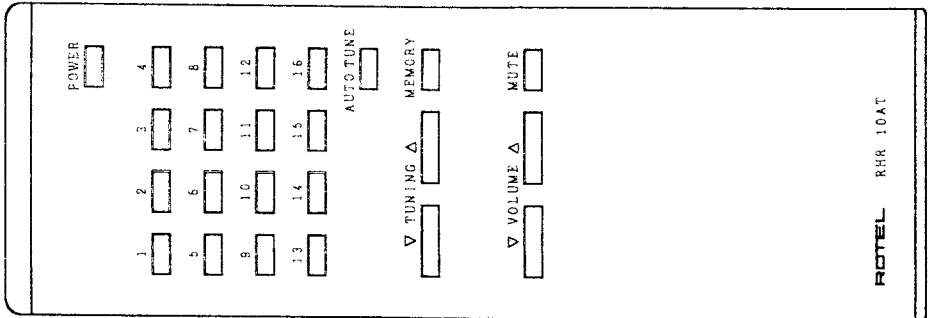
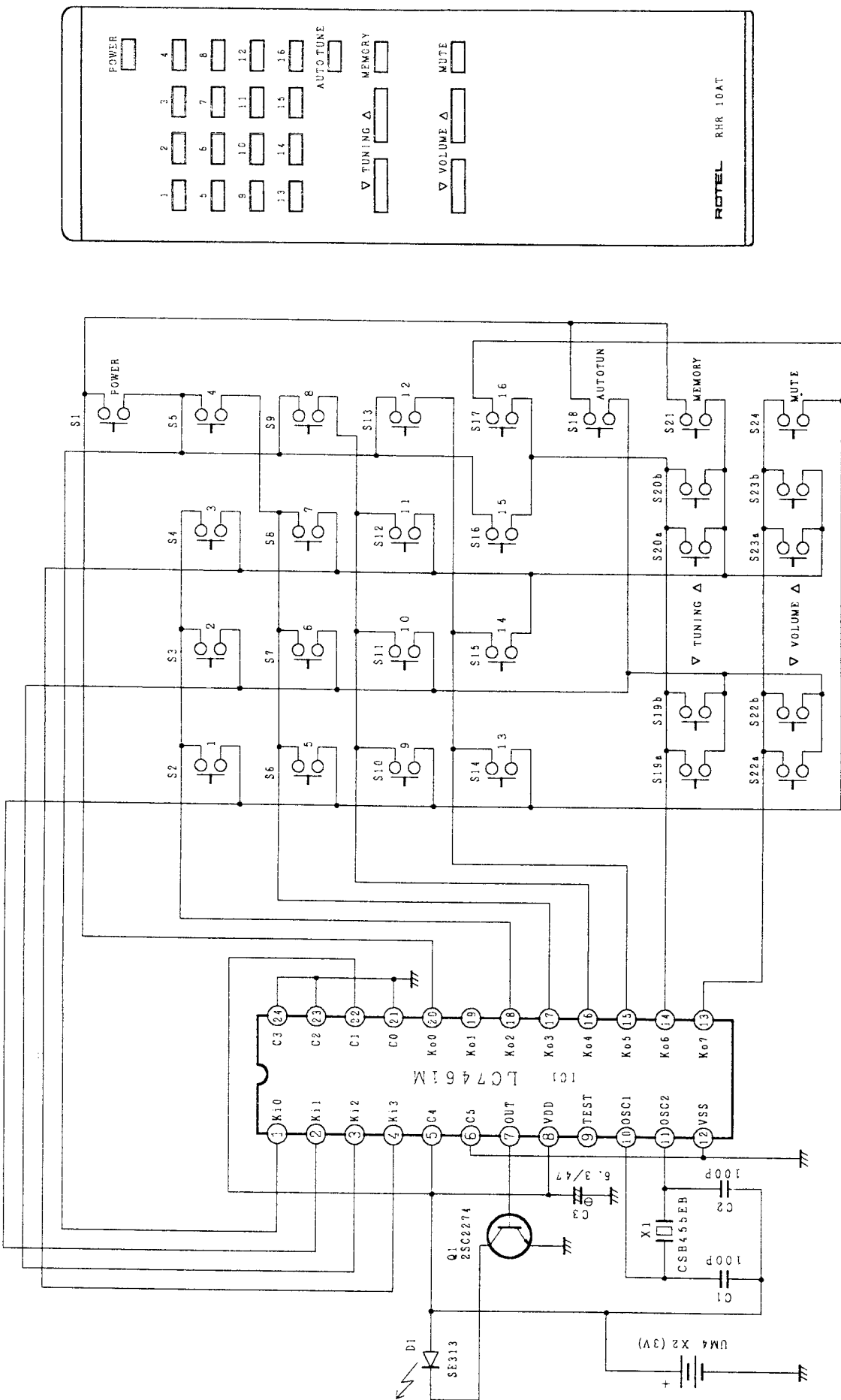

016E-1193A00

POWER

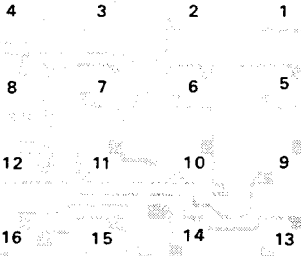

AUTO TUNE

MEMORY ▲ TUNING ▼

MUTE ▲ VOLUME ▼

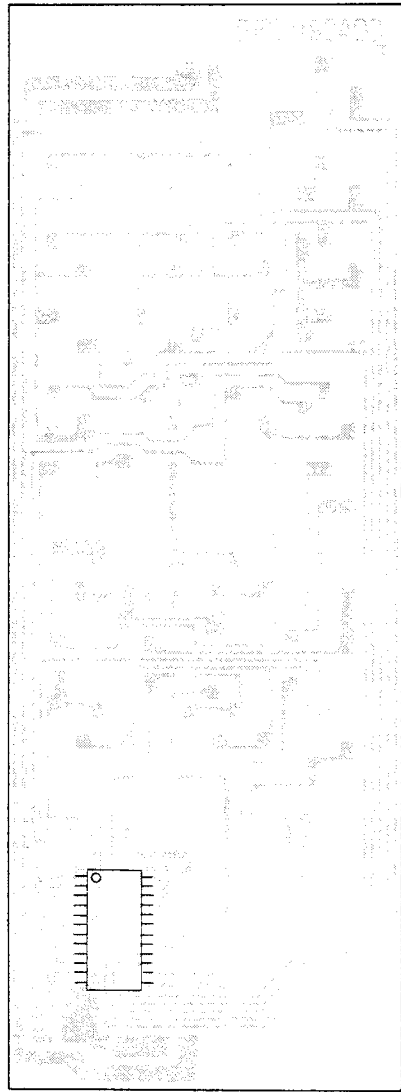
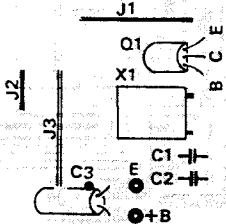

X1184B03T
S1L 300V
0A0E

CAUTION: REPLACE ONLY WITH SAME TYPE FUSE
ATTENTION: UTILISER UN FUSIBLE DE RECHANGE DE MEME TYPE

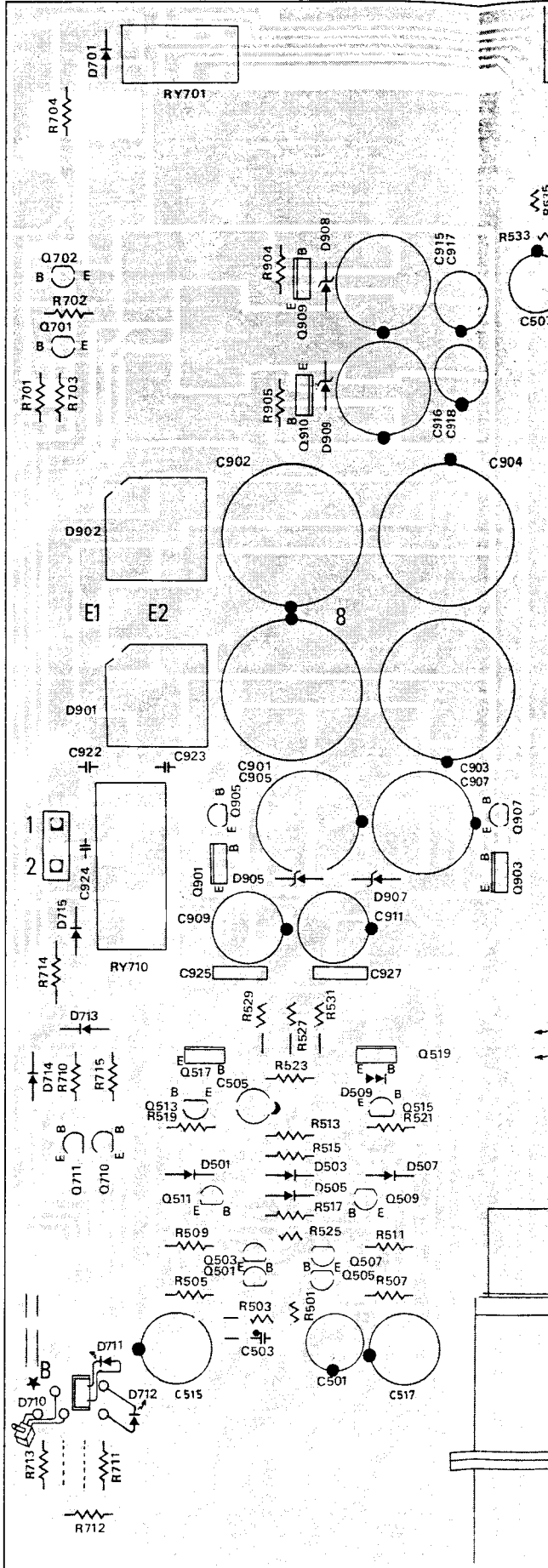
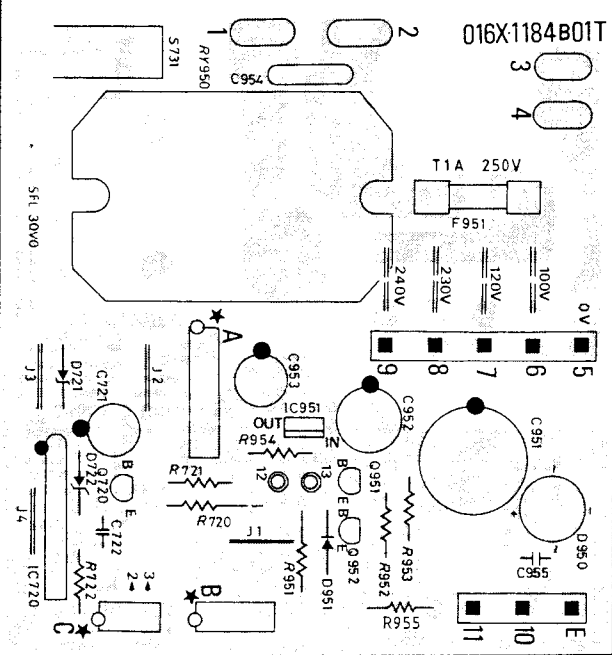
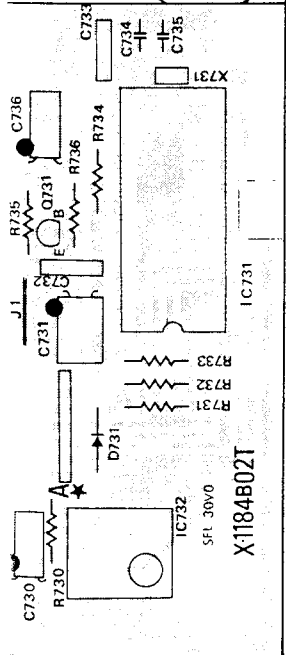

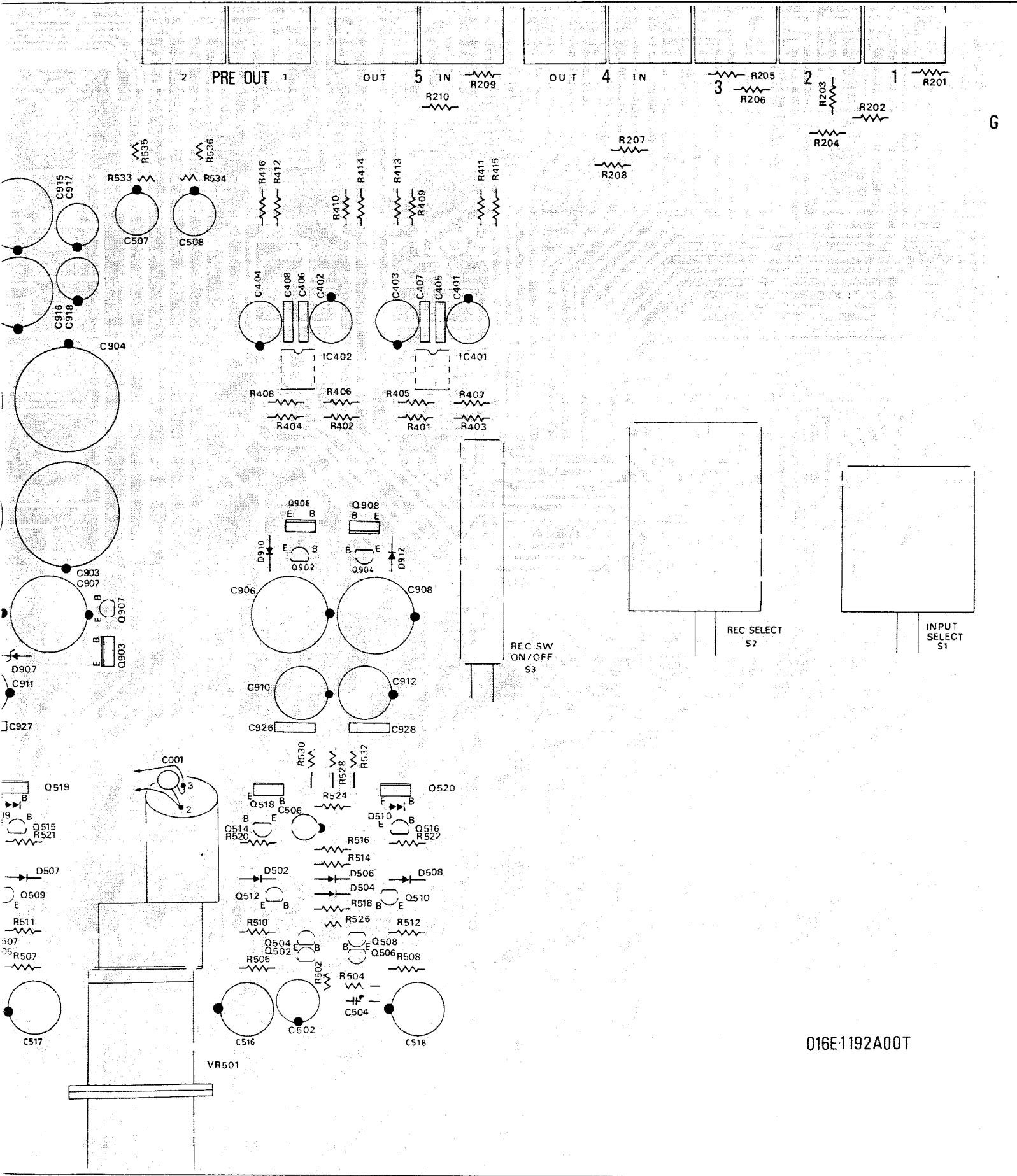

016E-1192A00T

LEFT INPUT

RIGHT INPUT

LEFT OUTPUT

RIGHT OUTPUT

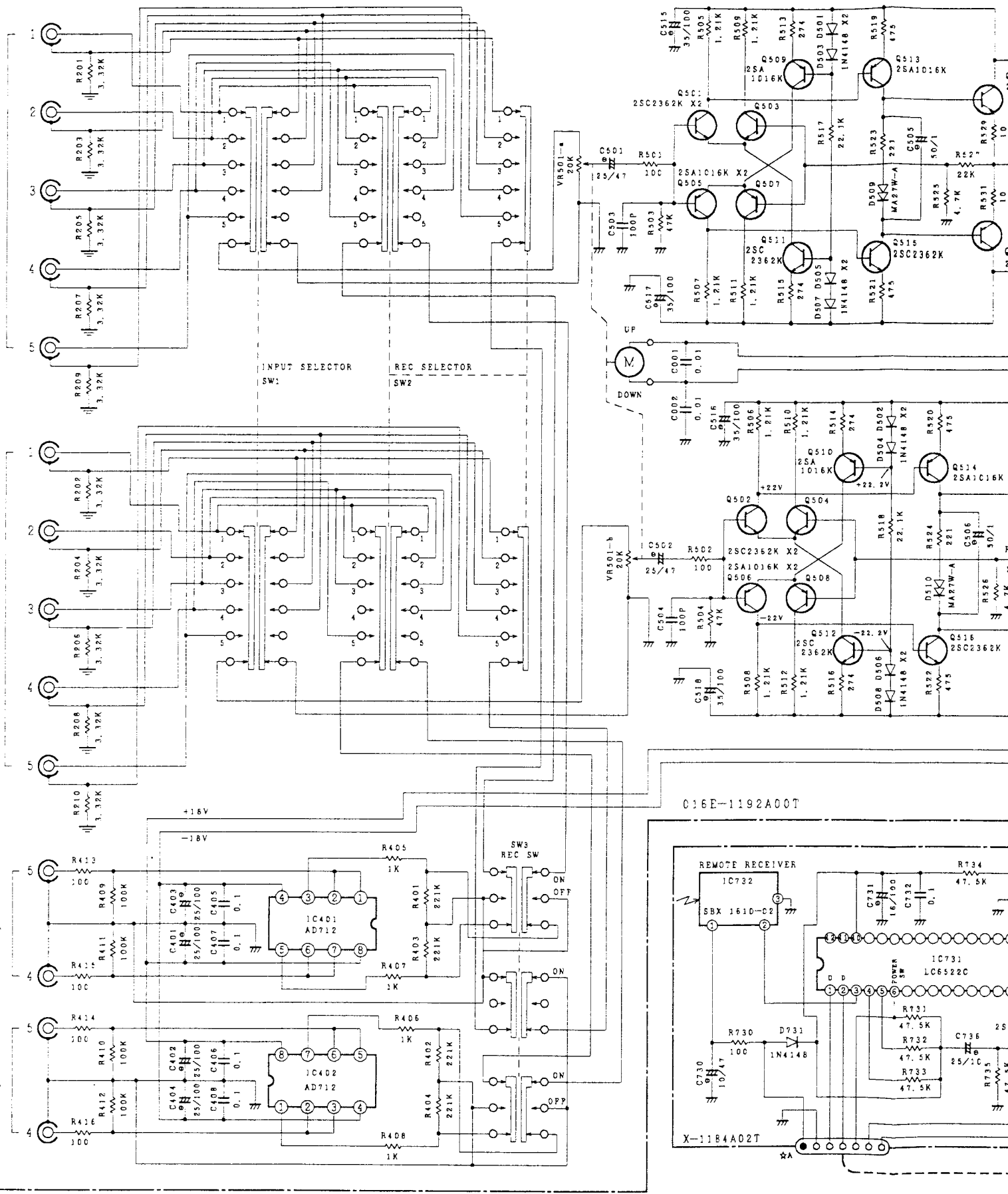

C16E-1192A00T

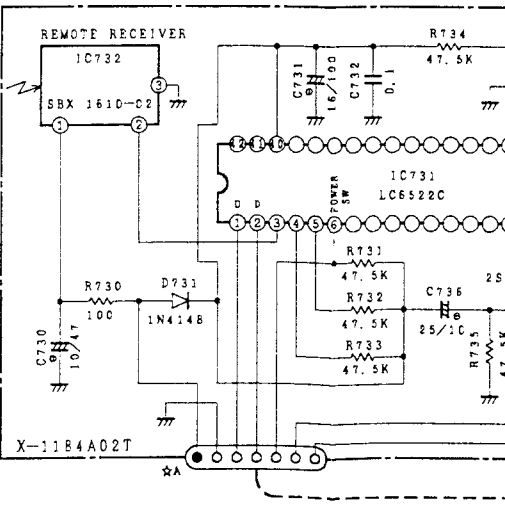

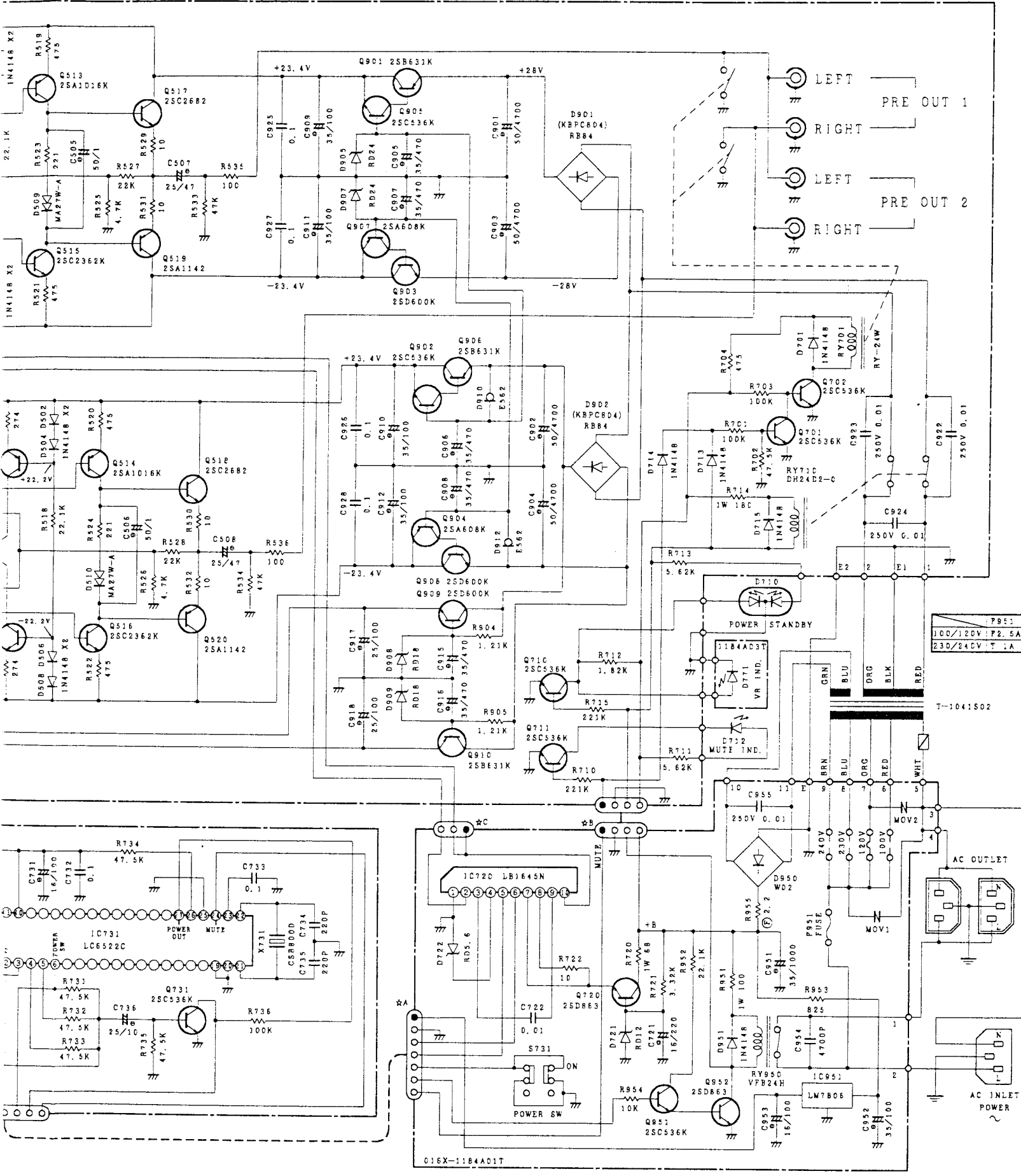

P951
100/120V P2.5A
230/240V T 1A

T-1041502

016X-1184AD1T