

Quality. Uncompromised.

**ROTEL**®

# Technical Manual

**MICRO COMPONENT 80 SYSTEM**

STEREO CASSETTE DECK  
**RMD-80**

STEREO INTEGRATED AMPLIFIER  
**RMA-80**

AM/FM STEREO TUNER  
**RMT-80/-80L**

## TABLE OF CONTENTS

INTRODUCTION . . . . .	2
ADDENDA . . . . .	2
I. CASSETTE DECK RMD-80	
Adjustment . . . . .	4
Troubleshooting Guide . . . . .	5
Block Diagram . . . . .	6
Record/Playback Level Diagram . . . . .	7
Disassembly Diagram . . . . .	8
II. TUNER RMT-80/-80L	
Adjustment . . . . .	11
Dial Stringing Diagram . . . . .	14
SPECIFICATIONS . . . . .	15
REPAIR PARTS LIST . . . . .	16
CHASSIS LAYOUT . . . . .	19
SCHEMATIC DIAGRAM . . . . .	21
CIRCUIT BOARD DIAGRAMS. . . . .	25

## TABLE DES MATIERES

INTRODUCTION . . . . .	2
ADDENDA . . . . .	2
I. MAGNETOCASSETTE RMD-80	
Réglage . . . . .	4
Guide de dépannage . . . . .	5
Schéma synoptique . . . . .	6
Diagramme du niveau d'enregistrement/lecture . . . . .	7
Schéma de démontage . . . . .	8
II. TUNER RMT-80/-80L	
Réglage . . . . .	11
Diagramme du câble d'entraînement . . . . .	14
CARACTERISTIQUES . . . . .	15
LISTE DES PIECES DE RECHANGE . . . . .	16
INSTALLATION DU CHASSIS. . . . .	19
DIAGRAMME SCHEMATIQUE . . . . .	21
DIAGRAMMES DES PLAQUETTES DES CIRCUITS IMPRIMES. . . . .	25

Serial Nos. Beginning  
NC89755

**THE ROTEL CO., LTD.**  
**ROTEL ELECTRONICS CO., LTD.**  
**ROTEL OF AMERICA, INC.**  
**ROTEL HI FI LIMITED.**

1-36-8 OHOKAYAMA, MEGURO-KU, TOKYO 152, JAPAN  
2ND FLOOR, EVERGLORY BLDG., NO. 305, SECTION 3,  
NANKING E. ROAD, TAIPEI, TAIWAN, REPUBLIC OF CHINA  
13528 SO. NORMANDIE, GARDENA, CALIF. 90249, U.S.A.  
2-4 ERICA ROAD, STACEY BUSHES, MILTON KEYNES,  
BUCKINGHAMSHIRE, ENGLAND

# Introduction

This booklet contains technical instructions for Rotel Micro-80 system: RMA-80, RMD-80 and RMT-80/-80L. Among the models, RMD-80 and RMT-80/-80L are not equipped with their own power supply section. They are designed to receive power from RMA-80. Therefore, when repairing RMD-80 or RMT-80/-80L, power should be supplied through RMA-80. If a separate power supply is used instead of RMA-80, the voltage applied and connections should be the same as with RMA-80.

## ADDENDA

### I. RMA-80

A. Power transformer for Europe and U.K. units has been changed from the conventional toroidal type (T-132E) to 2L type (T-143E). Toroidal type (T-132E) is available for repair purpose only.

### II. RMD-80

A. Auto-shut-off circuit has been partially modified as follows:

- Stop-sensor is changed from hall-IC to reed-switch type (see Fig. A) because of short supply of hall ICs.
- Accordingly, p-c board designation has been changed from X-386A to X-413. The size and terminal locations of the new p-c board remain the same as in X-386A, so that those two types are interchangeable.
- No circuit constant has been changed. (See p-c board diagrams on page 25).
- If constant supply of hall-ICs becomes available, the X-386A p-c board assembly may be used again.

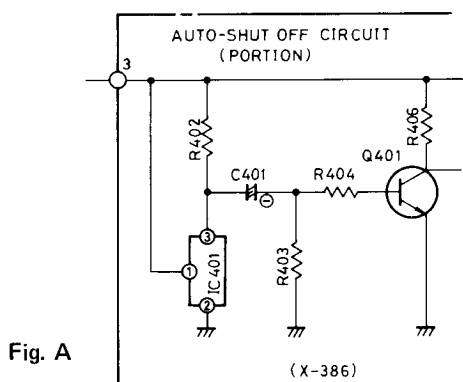

### III. RMT-80L

A. Specification for AM antenna coil has been changed: Symbol No. for this coil has been altered from RL-209 to RL-209A. Part No. remains the same. For a repair purpose, only new type coil will be supplied. Because of this change, L002 and C251 have been removed as shown in Fig. B. Therefore, when replacing conventional coil with a new one, L002, 1mH and C251, 10pF should be removed. Circuit diagrams in this booklet are drawn based on new circuitry.

# Introduction

La présente brochure contient des instructions techniques relatives à Système Micro-80 de Rotel: RMA-80, RMD-80 et RMT-80/-80L. Parmi ces modèles, RMD-80 et RMT-80/-80L ne comportent pas en propre de section d'alimentation. Ils sont conçus pour être alimentés à partir du RMA-80. En conséquence, lors de la réparation de RMD-80 ou de RMT-80/-80L, l'alimentation doit être fournie par le RMA-80. Dans le cas où une source d'alimentation séparée est utilisée à la place du RMA-80, la tension fournie et les branchements doivent être les mêmes que pour le RMA-80.

## ADDENDA

### I. RMA-80

A. Le transformateur de puissance pour les modèles à destination de l'Europe et du Royaume Uni est modifié: le type toroïdal conventionnel (T-132E) est remplacé par le type 2L (T-143E). Le type toroïdal (T-132E) n'est disponible qu'aux fins de réparation.

### II. RMD-80

A. Le circuit d'arrêt automatique a été modifié comme suit:

- Le détecteur d'arrêt, auparavant un CI-Hall est remplacé par un commutateur à lame (voir Fig. A), du fait du manque de CI Hall.
- En conséquence, la désignation de la plaquette de circuit imprimé est modifiée de X-386A à X-413. Les dimensions et les emplacements des bornes de la nouvelle plaquette restent les mêmes que pour la plaquette X-386A, de sorte que les deux types sont interchangeables.
- Aucune constante du circuit n'a été changée. (Voir les schémas de plaquettes de circuits page 25.)
- Dans le cas où il devient possible d'obtenir de façon stable des CI-Hall à nouveau, la plaquette X-386A peut être utilisée à nouveau.

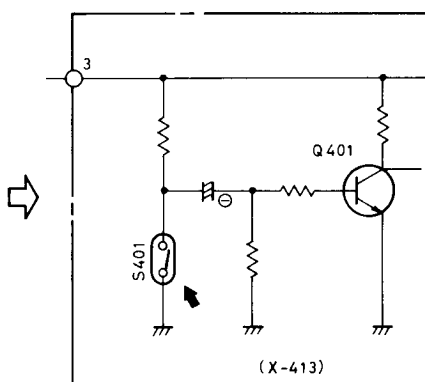

### III. RMT-80L

A. La spécification de la bobine d'antenne MA est modifiée: le No. de symbole de cette bobine, RL-209, est remplacé par le No. RL-209A. Le No. de Pièce reste le même. Pour les réparations, seul le nouveau type de bobine sera fourni. En raison de cette modification, L002 et C251 ont été supprimés, comme indiqué sur la Fig. B. En conséquence, lors du remplacement de la bobine conventionnelle par une neuve, L002, 1mH et C251, 10pF, doivent être enlevés. Les schémas de cir-

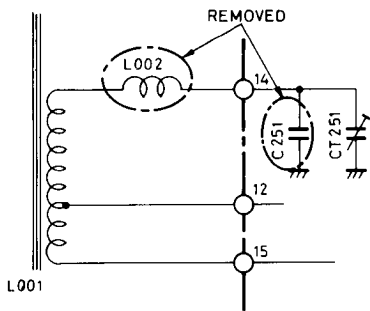

Fig. B

cuit de la présente brochure sont basés sur les nouveaux types de pièces.

**IV. RMT-80/-80L**

A. Transistor Q204 for AM tuning indicator driver has been changed from 2SC1684 to 2SC2634. Together with this change, the decoupling capacitor C220 at collector side of Q204 has been changed from 1mfd to 100mfd. Circuit diagrams in this booklet are drawn based on new circuitry.

B. Circuit constant of FM OSC has been changed:  
 1. CT102 has been changed from 20pF max. ( $N800 \pm 300 \times 10^{-6}$ ) to 10pF max. ( $NPO \pm 200 \times 10^{-6}$ ) (Part No. 490110124). Together with this change, capacitor C105 connected in parallel with this trimmer has been changed from mica type, 20pF to ceramic type, 24pF PH(N150) (Part No. 443241237).

For the units destined for South Africa, the following change has been made:

- CT102: Same as STD spec.
- C105: 10pF → 15pF RH (Part No. 443151232)

The reason for the above change: to prevent frequency drift due to temperature change.

The change given above is applicable to the units with Serial No. beginning ND75906.

**IV. RMT-80/-80L**

A. Le transistor Q204 pour le driver de l'indicateur d'accord MA est modifié de 2SC1684 à 2SC2634. En fonction de cette modification, le capaciteur de découplage C220 du côté collecteur de Q204 passe de 1mfd à 100mfd. Les schémas de circuit de la présente brochure sont basés sur les nouveaux types de pièces.

B. La constante de circuit de FM OSC a été modifiée:  
 1. CT102 passe de 20pF max. ( $N800 \pm 300 \times 10^{-6}$ ) à 10 pF max. ( $NPO \pm 200 \times 10^{-6}$ ) (No. de Pièce 490110124). En fonction de cette modification, le capaciteur C105 branché en parallèle avec ce capaciteur d'appoint, jusqu'à présent de type mica, 20pF, est remplacé par le type céramique, 24pF PH(N150) (No. de Pièce 443241237). Pour les modèles destinés à l'Afrique du Sud, la modification suivante a été apportée:

- CT102: Identique au type STD.
- C105: 10pF → 15pF RH (No. de Pièce 443151232)

Cette modification a été effectuée afin d'obtenir une meilleure tenue en matière d'excursion de fréquence due aux variations de température.

Cette modification s'applique aux unités dont le No. de série commence à ND75906.

**V. RMA-80, RMD-80 and RMT-80/-80L**

A. Front panel assembly has been changed:  
 1. Push button assembly conventionally installed on the front panel has been separated from the front panel module. Front panel assembly for repair is supplied without push buttons. New push buttons are supplied for each function separately.

- a) Part No. for new front panel:
  - for RMA-80 . . . . 111911548
  - for RMD-80 . . . . 111911549
  - for RMT-80 . . . . 111911550
  - for RMT-80L . . . 111911551
- b) Part No. for new push buttons
  - for Function, Power, etc. (14 x 4) . . 116210092
  - for Loudness, Muting,
  - Dolby NR (□5) . . . . . 116210094

**V. RMA-80, RMD-80 et RMT-80/-80L**

A. Le panneau de façade fait l'objet d'une modification:  
 1. Le groupe bouton-poussoir figurant auparavant sur le panneau est séparé du panneau de façade. En conséquence, le panneau de façade pour réparation est fourni sans boutons-poussoirs. Les boutons-poussoirs sont fournis séparément.

- a) No. de Pièce du nouveau panneau de façade:
  - pour RMA-80 . . . . . 111911548
  - pour RMD-80 . . . . . 111911549
  - pour RMT-80 . . . . . 111911550
  - pour RMT-80L . . . . . 111911551
- b) No. de Pièce des nouveaux boutons-poussoirs:
  - pour Fonction, Général, etc (14 x 4). 116210092
  - pour Correction Physiologique, Amortissement,
  - Dolby NR (□5) . . . . . 116210094

## I. CASSETTE DECK

### ADJUSTMENT

**Instruments:** Audio Generator, AC VTVM, Oscilloscope, Test Tape (LCT-3004-C and LCT-7001 or equivalent), Metal Blank Tape (SONY Metallic Tape)

#### A. Azimuth Adjustment

1. Set Tape Selector to NORMAL and Dolby NR switch to OFF.
2. Insert Test Tape (LCT-3004-C or equivalent) into deck and play it back.

Adjust azimuth screw (Fig. 1) to increase the output levels of both channels at playback to maximum and reduce the difference in output between left and right channels to minimum.

3. After adjustment, fix the azimuth screw with paint.

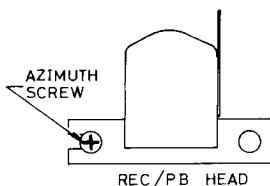

Fig. 1

#### B. Rec Bias Adjustment

1. Insert metal blank tape into the deck. Set Tape Selector to METAL, Dolby NR switch to OFF, Bias Control to mid-position, and Rec Level control to maximum.
2. Apply 400Hz signal into LINE IN (L-ch) from Audio Generator (AG). Adjust output of AG so that Line output level is 58mV. Record this signal. Change the frequency of AG to 10,000Hz (with the input at the same level). Then record the signal. Adjust potentiometer VR105 on REC/PB p-c board (Fig. 2), by recording and playing back, until outputs for 10,000Hz and 400Hz signals reach the same level.
3. Carry out this adjustment for R-ch, using potentiometer VR106 on REC/PB p-c board.

#### C. Playback Level Adjustment

1. Set Tape Selector to NORMAL and Dolby NR switch to OFF. Connect AC Voltmeter to Line Out.
2. Play back Test Tape LCT-7001 (or equivalent), and adjust potentiometer VR101 (VR102 for R-ch) on REC/PB p-c board (Fig. 2) so that AC Voltmeter reads 580mV.

#### D. Record Level Adjustment

1. Set Tape Selector to METAL, Dolby NR switch to OFF and Rec Level Control to maximum. Connect Audio Generator (AG) to Line In and AC Voltmeter and Oscilloscope to Line Out.
2. Insert metal tape (SONY's Metallic Tape) into the deck, and depress REC, PLAY and PAUSE buttons. Apply 400Hz (sine wave) signal from AG. Adjust output of AG so that AC Voltmeter reads 580mV.
3. Record this signal. Check to see that AC Voltmeter reads 580mV when playing back the recorded tape.
4. If recording and playback levels differ from each other, repeat the step 3 until the two levels become almost equal, by adjusting potentiometer VR103 (VR104 for R-ch) on REC/PB p-c board (Fig. 2) while recording.

## I. MAGNETOCASSETTE

### REGLAGE

**Instruments:** Générateur d'audio-fréquences, VTVM CA, Bande d'essai (LCT-3004-C et LCT-7001 ou équivalente), Bande au métal (Metallic tape de SONY)

#### A. Réglage de l'azimut

1. Régler le sélecteur de bande sur la position NORMAL et mettre l'interrupteur Dolby NR sur OFF.
2. Mettre en place et passer la bande d'essai (LCT-3004-C ou équivalente). Régler la vis d'azimut (Fig. 1) pour augmenter le niveau de sortie des deux canaux à la reproduction au maximum et pour réduire au minimum la différence entre les niveaux de sortie des canaux droite et gauche.
3. Après avoir effectué le réglage, enduire la vis d'azimut de peinture.

#### B. Réglage de polarisation d'enregistrement

1. Insérer une bande vierge au métal dans la platine de magnétophone. Régler le Sélecteur de bande sur METAL, l'interrupteur Dolby NR sur OFF, la commande de polarisation en position médiane et la commande de niveau d'enregistrement sur la position maximum.
2. Injecter un signal de 400Hz sur la borne LINE IN (Canal de gauche) à l'aide d'un générateur de signaux. Ajuster la sortie du générateur de façon à obtenir un niveau de sortie de ligne de 58mV. Enregistrer le signal sur la bande. Modifier le réglage du générateur audio, sur 10.000Hz (l'entrée restant au même niveau). Enregistrer le signal. Ajuster ensuite le potentiomètre VR105 de la plaquette de circuit REC/PB (voir Fig. 2) tout en répétant les opérations d'enregistrement et d'écoute, jusqu'à ce que les sorties correspondant aux signaux de 10.000Hz et 400Hz atteignent le même niveau.
3. Effectuer le même réglage pour le canal de droite également, à l'aide du potentiomètre VR106 de la plaquette de circuit REC/PB.

#### C. Réglage du niveau de lecture

1. Régler le sélecteur de bande sur NORMAL et l'interrupteur Dolby NR sur OFF. Brancher un voltmètre CA sur la borne de sortie de ligne.
2. Procéder à l'écoute de la bande d'essai LCT-7001 ou un équivalent et ajuster le potentiomètre VR101 (VR102 pour le canal de droite) sur la plaquette de circuit REC/PB (voir Fig. 2) de façon à obtenir sur le voltmètre CA un affichage de 580mV.

#### D. Réglage du niveau d'enregistrement

1. Régler le sélecteur de bande sur la position METAL, l'interrupteur Dolby NR sur la position OFF et la commande de niveau d'enregistrement sur la position maximum. Brancher un générateur de signaux audio sur l'entrée de ligne et un voltmètre CA ainsi qu'un oscilloscope sur la sortie de ligne.
2. Insérer une bande au métal (Metallic Tape de Sony) dans la platine et presser les commandes REC, PLAY et PAUSE. Injecter un signal de 400Hz (onde sinusoïdale) à partir du Générateur audio. Ajuster la sortie du générateur de signaux de façon que le voltmètre CA affiche la valeur 580mV.

3. Enregistrer le signal sur la bande. Vérifier que le voltmètre CA affiche bien 580mV lors de la lecture de la bande précédemment enregistrée.
4. Si une différence est relevée entre les niveaux d'enregistrement et de lecture, répéter l'opération du point 3 en ajustant le potentiomètre VR103 (VR104 pour le canal de droite) de la plaquette de circuit REC/PB (voir Fig. 2) lors de l'enregistrement.

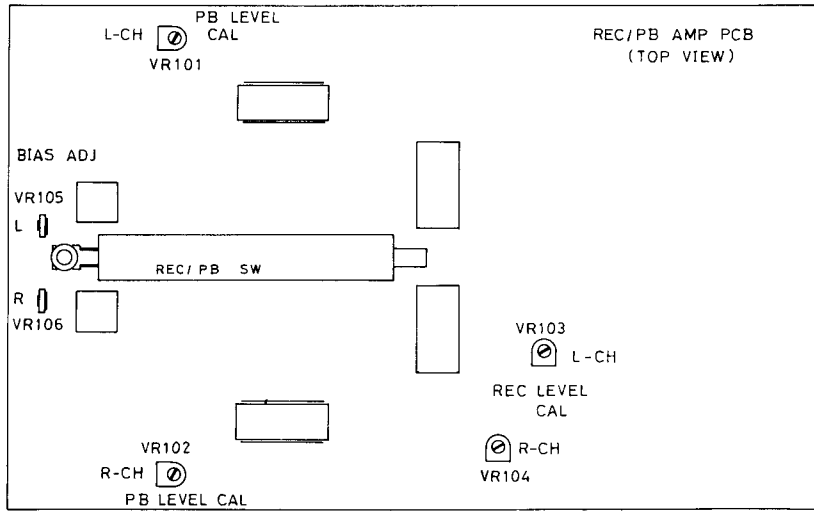

Fig. 2

## Troubleshooting Guide RMD-80

- A. Tape does not feed at constant speed on PLAY.**
1. Failure of pinch roller, or
  2. Pinch roller is dirty with oil, dirt or other foreign matters, or
  3. Inadequate pressure from pinch roller,
    - a) Failure of pressure spring, or
  4. Capstan or belt is oily, or
  5. Take-up reel pulley is dirty, or
  6. Inadequate back tension.
- B. Too much wow on PLAY**
1. Check items 1 through 6 in phase A.
  2. Capstan is bent, or
  3. Belt deformation.
- C. Neither recording nor playback can be made.**
1. Transistor Q101 or Q103 (Q102 or Q104 for R-ch) on REC/PB p-c board may be faulty, or
  2. IC101 (IC102 for R-ch) on REC/PB p-c board may be faulty, or
  3. REC/PB switch may be faulty, or
  4. REC/PB head may be faulty.
- D. Recording alone cannot be made.**
1. Transistor Q105 or Q107 (Q106 or Q108 for R-ch) may be faulty, or
  2. Rec Bias circuit may be faulty.

### NOTE:

When replacing REC/PB switch, take note of the following items.

1. Make sure the orientation of the switch is correct. (Longer one of the movable projections should be toward the center of p-c board.)
2. Attach the pulley to the shorter projection of the switch (Fig. C). When attaching the pulley mount-

## Guide de dépannage RMD-80

- A. En reproduction (PLAY), la bande ne défile pas à vitesse constante.**
1. Galet presseur défectueux, ou
  2. Galet presseur sale ou recouvert d'huile ou autres corps étrangers, ou
  3. Pression inadéquate du galet presseur,
    - a) Ressort de pression défectueux, ou
  4. Cabestan ou courroie enduit d'huile, ou
  5. Roue de la bobine réceptrice sale, ou
  6. Tension arrière inadéquate.
- B. Trop de pleurage à la lecture.**
1. Vérifier chaque point de 1 à 6 de la phase A.
  2. Le cabestan est tordu, ou
  3. La courroie est déformée.
- C. Ni l'enregistrement ni la lecture ne sont obtenus.**
1. Transistor Q101 ou Q103 (Q102 ou Q104 pour le canal de droite) de la plaquette de circuit REC/PB défectueux, ou
  2. IC101 (IC102 pour le canal de droite) de la plaquette de circuit REC/PB défectueux, ou
  3. Commutateur REC/PB défaillant, ou
  4. Tête REC/PB défaillante.
- D. Seul l'enregistrement ne peut être obtenu.**
1. Les transistors Q105 ou Q107 (Q106 ou 108 pour le canal de droite) sont défectueux, ou
  2. Le circuit de polarisation d'enregistrement est défaillant.

### NOTE:

Lors de la pose du commutateur Enregist./Lecture, suivre la séquence suivante.

1. Veiller à bien orienter le commutateur. (La saillie la plus longue doit être orientée vers le centre de la plaquette.)

ing plate to the switch, be careful not to tighten the mounting screw excessively (Fig. C).

- The tension of the wire for switching the REC button should be adjusted carefully: neither too loose or too tight setting allows correct switching. Adjust the tension with the switch set in the playback mode. Loosen the screw on tension adjuster, and operate the adjuster in either direction indicated by arrow as shown in Fig. D. When making adjustment, do not let the switch turn into the record mode (i.e. the projection of the switch should not move toward the adjuster). Optimal tension should be obtained when the wire is in a slightly loose condition, but not to the extent of slackening.

- If the tension of wire is too tight, the switch will be incapable of returning to playback mode on switching from REC to PB, resulting in unstable playback action.
- If too loose, switching into the REC mode will not be made correctly.

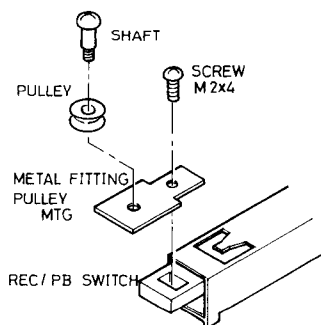

Fig. C

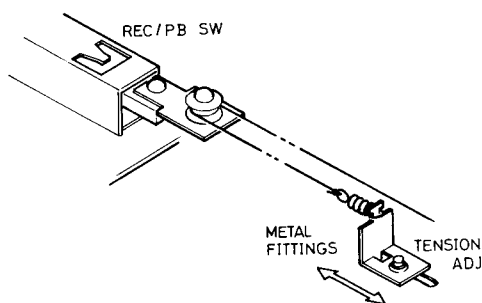

Fig. D

- Fixer la poulie sur la saillie la plus courte du commutateur (Fig. C). Prendre soin de ne pas serrer trop la vis de fixation de la plaque de montage de la poulie sur le commutateur (Fig. C).
- La tension du fil du commutateur de commande d'Enregis. doit faire l'objet d'un réglage précis: ni trop lâche ni trop tendue, de façon à permettre un mouvement correct. Ajuster la tension lorsque le commutateur est en position de lecture. Desserrer la vis du tendeur et décaler celui-ci dans l'une des directions indiquées par la flèche, comme illustré sur la Fig. D. Lors de ce réglage, le commutateur ne doit pas passer en mode d'enregistrement (la saillie du commutateur ne doit pas se déplacer vers le tendeur). La tension optimale est obtenue lorsque le fil est quelque peu lâche, mais sans accuser de flèche.
  - Si la tension du fil est trop élevée, le commutateur ne peut revenir en mode de lecture lors du passage de REC à PB, ce qui provoque un mouvement instable lors du passage à la lecture.
  - Si la tension est trop faible, le passage en mode REC ne peut s'effectuer correctement.

## Block Diagram

## Schéma synoptique

RMD-80

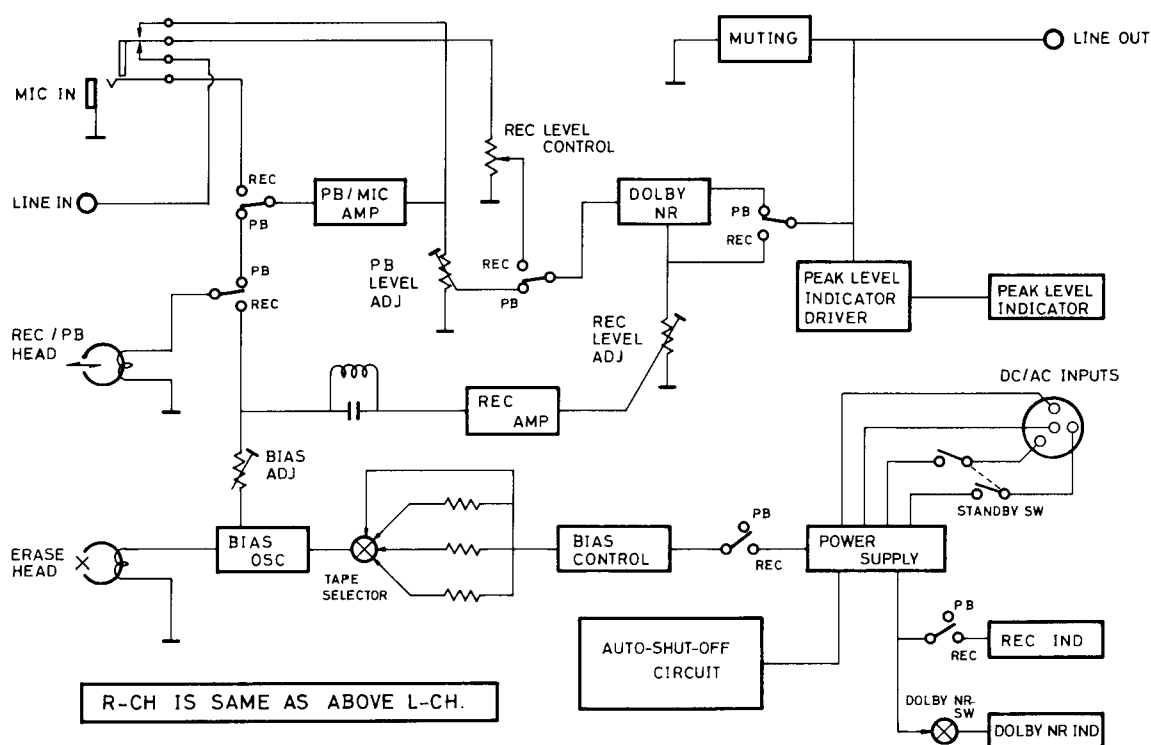

**RECORD/PLAYBACK LEVEL DIAGRAM**  
**DIAGRAMME DU NIVEAU D'ENREGISTREMENT/LECTURE**

**PLAYBACK MODE**  
**MODE DE LECTURE RMD-80**

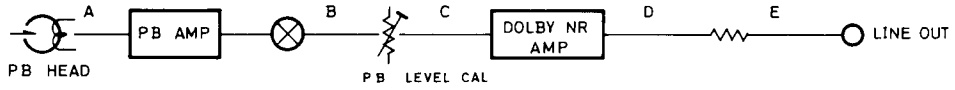
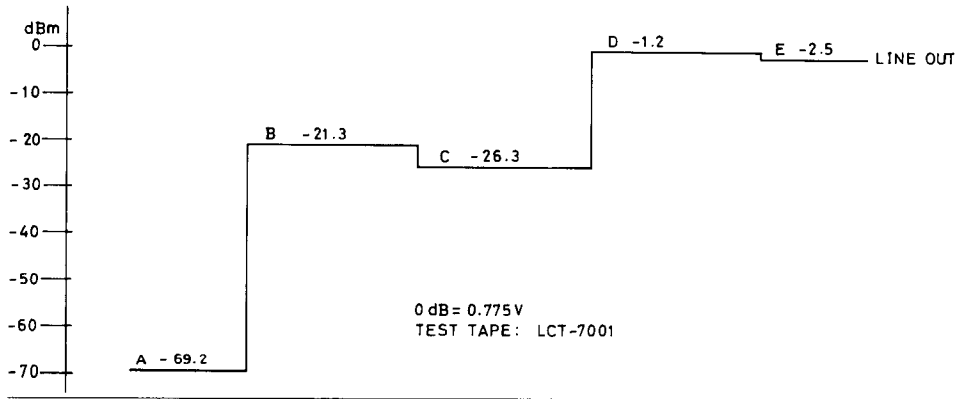

**RECORDING MODE**  
**MODE D'ENREGISTREMENT RMD-80**

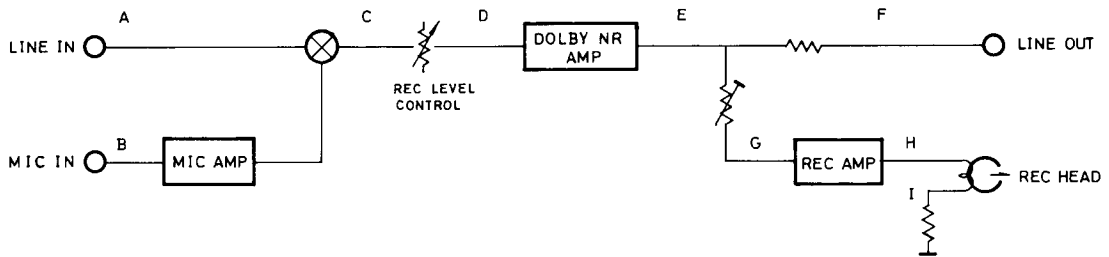
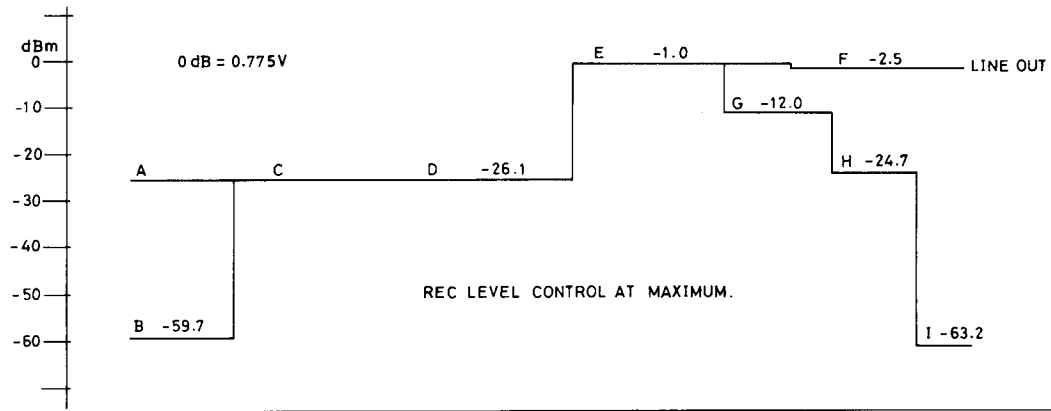

## Disassembly Diagram

## Schéma de démontage

No.	Description	Part No.	No.	Description	Part No.
1.	Chassis Ass'y	090221101	63.	Dust Cover (B)	090221121
2.	Eject Lever Ass'y	090221102	64.	Lamp Window	090221122
3.	Lever Spring (B)	090226151	65.	Lamp (12V, 63mA)	350120006
4.	Rec Lever	090221103	66.	Eject Lever (C)	090221123
5.	Play Lever	090221104	67.	Eject Lever Spring (B)	090226182
6.	Brake Lever	090221105	68.	Button Holder (L)	090221124
7.	Brake Shoe	090226152	69.	Button Holder (R)	090221125
8.	Brake Spring	090226153	70.	Cassette Case Ass'y	090221126
9.	Play Idler Arm	090221106	71.	Case Clamp Spring	090226182
10.	Idler Arm Spring	090226154	72.	Not used	—
11.	FF Tension Spring	090226155	73.	Button Lever	116210075
12.	FF Lever	090221107	74.	Button Shaft (B)	090226183
13.	FF Lever Spring	090226156	75.	Button Collar	090227204
14.	Cassette Guide	090221108	76.	Case Up Spring	090226184
15.	Review Lever	090221109	77.	Damper Holder	090221127
16.	Rew Lever Spring (B)	090226157	78.	Damper Ass'y	090221128
17.	Pause Lever Ass'y	090221110	79.	Damper Link Ass'y	090221129
18.	Pause Lever Spring	090226158	80.	Solenoid Holder Ass'y	090221130
19.	Cam Plate (C)	090221111	81.	Solenoid	240111249
20.	Not used	—	82.	Solenoid Spring	090226185
21.	Cam Plate Spring (A)	090226159	83.	Auto Arm (C)	090221131
22.	Leaf Switch, Play	615212286	84.	Switch Holder	090221132
23.	Center Pulley Arm Ass'y	090221112	85.	Leaf Switch, Pause	615212288
24.	Center Arm Spring	090226160	86.	Center Arm Collar	090227205
25.	Motor Holder (B)	090221113	87.	Motor	260101130
26.	Motor Cushion	090226161	88 to 111	Not used	—
27.	Motor Ring	090227201	112.	Polyslider Washer, $\phi 1.6 \times \phi 1.3 \times t0.25$	770500079
28.	Motor Pulley	090226162	113.	Oil-seal Washer, $\phi 1.9 \times \phi 5 \times t0.5$	090227206
29.	Flywheel (B)	090226163	114.	Polyslider Washer, $\phi 2.1 \times \phi 4 \times t0.25$	770500080
30.	Belt	090226164	115.	Washer (A), $\phi 4.1 \times \phi 8 \times t0.25$	090227207
31.	Flywheel Bracket	090221114	116.	Not used	—
32.	Capstan Screw	090227202	117.	Not used	—
33.	Not used	—	118.	Plain Washer (L), $\phi 2$	090227208
34.	FF Idler	090226165	119.	Plain Washer (S), $\phi 2$	090227209
35.	Takeup Reel Ass'y	090226166	120.	Plain Washer (L), $\phi 2.6$	090227210
36.	Supply Reel Ass'y	090226167	121.	Plain Washer (S), $\phi 2.6$	090227211
37.	Back Tension Spring	090226168	122.	Plain Washer (L), $\phi 3$	090227212
38.	Pause Arm	090221115	123.	Not used.	—
39.	Play Idler	090226169	124.	Screw, M2 x 4, Pan	703202004
40.	Idler Bush	090226170	125.	Screw, M2 x 6, Pan	703202006
41.	Pause Cam	090221116	126.	Screw, M2.6 x 3, (BLK), Pan	703222603
42.	Pause Cam Spring	090226171	127.	Screw, M2.6 x 5, Pan	703202605
43.	Pack Clamp Spring	090226172	128.	Not used	—
44.	Rec Sensor	090221117	129.	Screw, M3 x 5, Pan	703203005
45.	Rec Sensor Spring	090226173	130.	Not used	—
46.	Sub-chassis Ass'y	090221118	131.	Screw, M2.6 x 5 w/SPW	713202605
47.	Sub-chassis Spacer	090226174	132.	Screw, M2.6 x 8 w/SPW	713202608
48.	Not used	—	133.	Screw, M3 x 5 w/SPW	713203005
49.	Not used.	—	134.	Not used	—
50.	Cord Clamp	090227203	135.	Screw, 2.6 x 4, Tap-tight	763202604
51.	Rec/PB Head	241001118	136.	Screw, 2.6 x 6, Tap-tight	763202606
52.	Erase Head	241001121	137.	Screw, 2.6 x 8, Tap-tight	763202608
53.	Head Spring	090226175	138.	Not used	—
54.	Panel Tension Spring	090226176	139.	Screw, M2 x 6, Bind	705002006
55.	Panel Spring (L)	090226177	140.	Screw, 2 x 6, Tapping	723202006
56.	Panel Spring (R)	090226178	141.	Not used	—
57.	Pinch Roller Arm Ass'y	090221119	142.	E-ring, $\phi 1.5$	770500026
58.	Pinch Roller Arm Spring	090226179	143.	E-ring, $\phi 2.5$	770500027
59.	Counter Holder (D)	090221120	144.	E-ring, $\phi 3$	770500039
60.	Counter Belt	090226180	145.	E-ring, $\phi 4$	770500040
61.	Counter	650901118	146.	Not used	—
62.	Leaf Switch, Muting	615212287	147.	Spring Pin	090227215



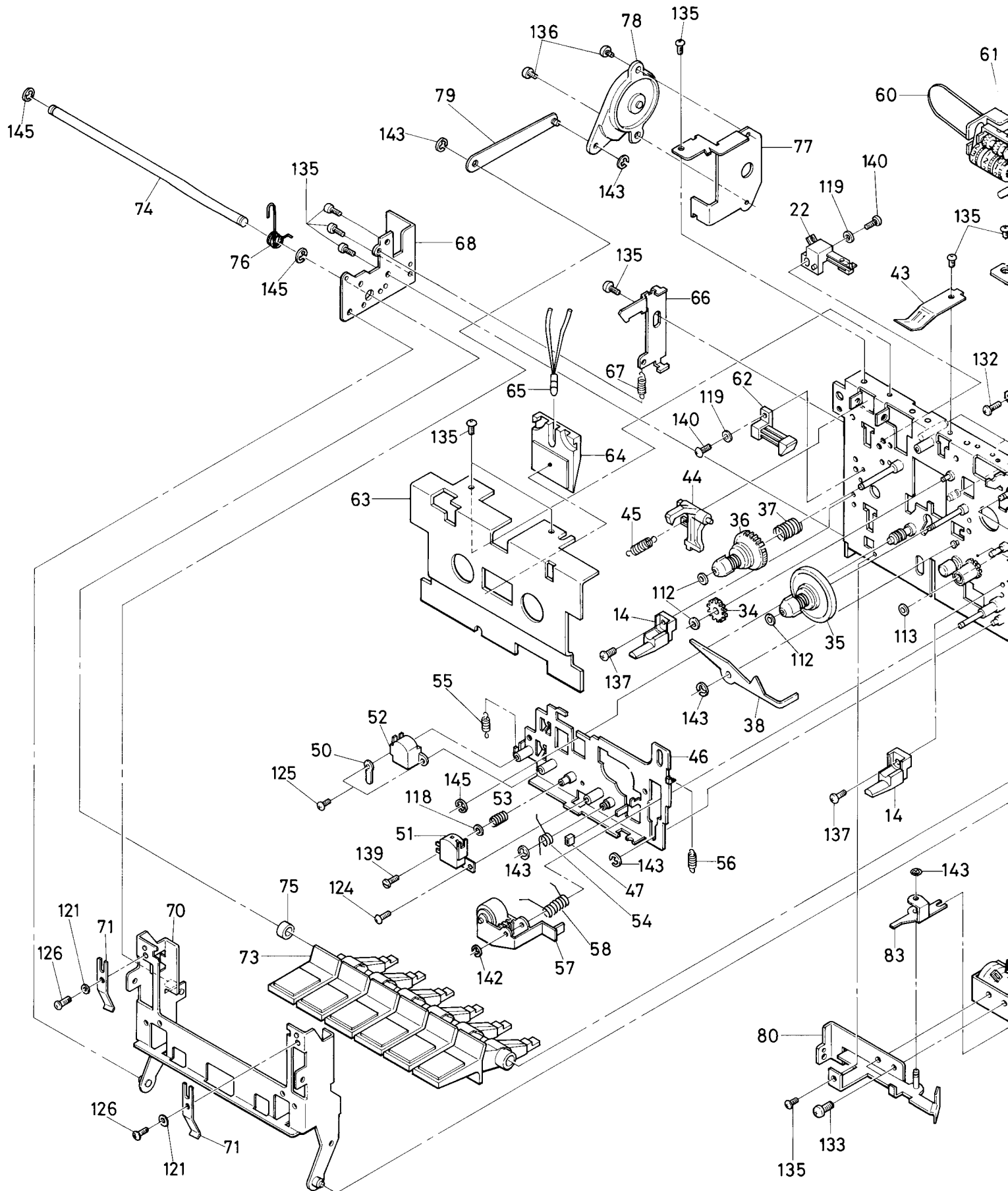

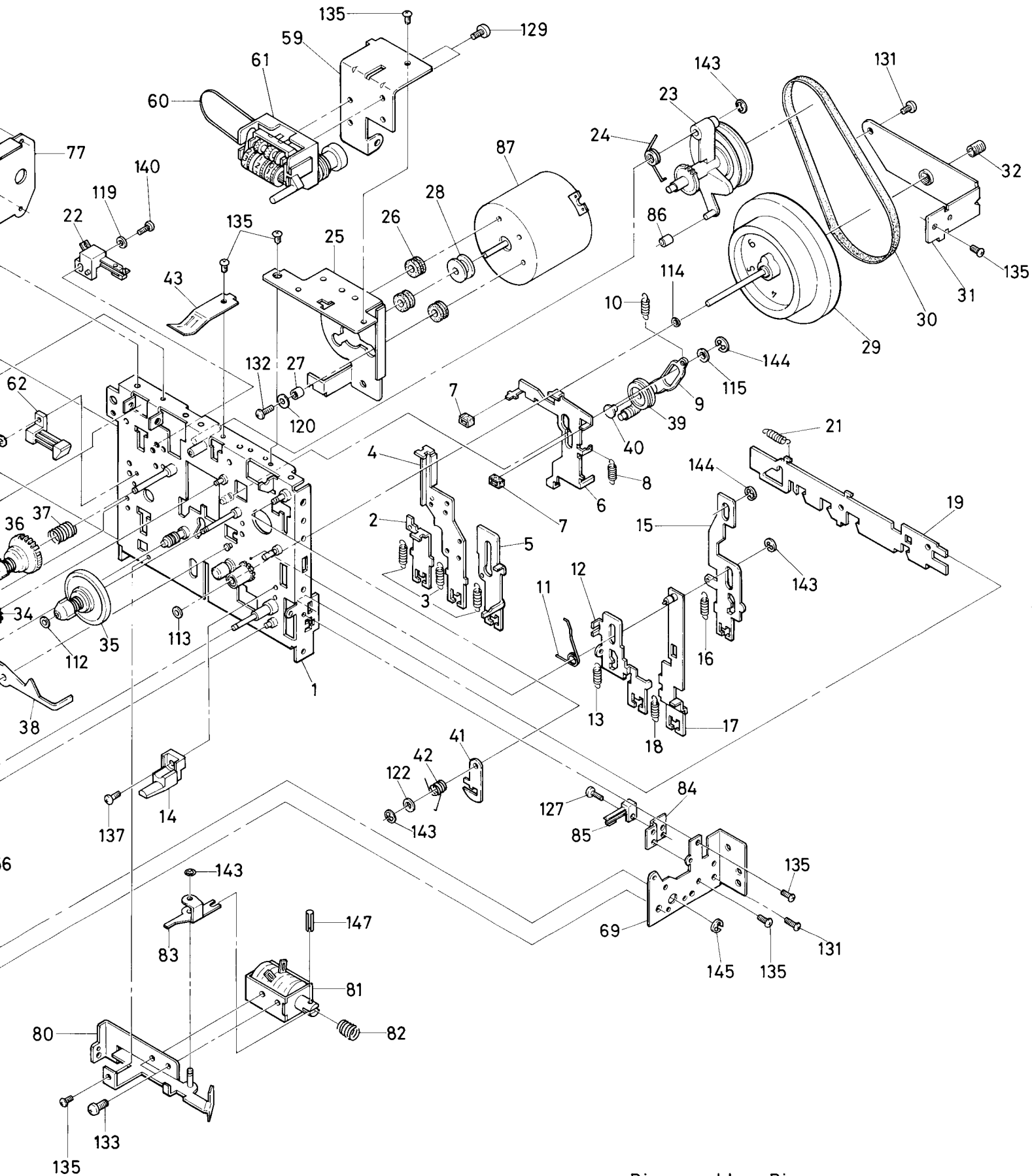

**Disassembly Diagram**  
MODEL NO. RMD-80  
1980, 7, 9 YORIKO TERAYAMA

## II. TUNER

### A. FM IF and RF Alignment

**Instruments:** FM Signal Generator, Oscilloscope, HD Analyzer, Zero-center Meter

- Set Function Selector to FM position beforehand.
- 1. Connect Zero-center Meter to test point (plus lead to pin 8 and minus lead to pin 7). \*<sup>1</sup>  
Connect Oscilloscope and HD Analyzer to OUTPUT (L-ch or R-ch).
- 2. Receive white noise, and adjust the bottom core of FM IFT L109 so that Zero-center Meter needle falls on mid-position.
- 3. Receive 90MHz signal from FM Signal Generator. Antenna input should be set to the optimal level where adjustment can be carried out satisfactorily with the appropriate amount of noise contained in the signal wave (3μV-5μV). Adjust FM IFT L105 so that the waveform is largest and contains noise uniformly on the top and bottom of the waveform. (See Fig. 3.)  
**Note:** Although two synchronizing points are available, be sure to synchronize at the upper point.
- 4. Repeat steps 2 and 3 until no further improvement is noticed.
- 5. Set the dial to 90MHz position precisely. Adjust FM OSC coil L102 to obtain 90MHz signal from FM SG, and adjust RF coils L103 and 101 to obtain maximum sensitivity at 90MHz.
- 6. Next, set the dial to 106MHz and switch the frequency of FM SG to 106MHz. Adjust FM OSC trimmer capacitor CT102 to receive 106MHz signal, and adjust RF trimmer capacitors CT103 and 101 for maximum sensitivity at 106MHz.
- 7. Repeat steps 5 and 6 until no further improvement is noticed.
- 8. Receive 90MHz (400Hz, 100% modulated, 1mV input) signal from FM SG. Adjust top core of FM IFT L109 to minimize distortion.  
If Zero-center Meter needle deviates from mid-position after adjustment in step 8, fine-adjust the bottom core of FM IFT L109.
- 9. Receive 90MHz, 1mV signal from FM SG in a manner that center indicator LED 2 (green) alone glows. (Needle of Zero-center Meter should fall on mid-position.)  
Maintaining this state;
  - a) Set the SG to a position 50kHz higher than 90 MHz, and adjust potentiometer VR172\*<sup>2</sup> so that LED 1 dimly glows.
  - b) Set the SG to a position 50kHz lower than 90MHz, and adjust potentiometer VR171\*<sup>3</sup> so that LED 3 dimly glows. See Fig. 3.

## II. TUNER

### A. Alignement FI MF et HF

**Instruments:** Générateur de signal MF, oscilloscope, analyseur à distorsion non-linéaire et compteur à centre zéro

- Placer le sélecteur de fonction à la position FM d'avance.
- 1. Brancher le compteur à centre zéro sur le point d'épreuve (conducteur positif à la broche 8 et conducteur négatif à la broche 7). Brancher l'oscilloscope et l'analyseur à distorsion non-linéaire sur OUTPUT (au canal droit ou gauche).
- 2. Recevoir le bruit blanc, et régler l'âme inférieure de FM IFT L109 de sorte que l'aiguille du compteur à centre zéro tombe sur la position moyenne.
- 3. Recevoir le signal de 90MHz du générateur de signal MF. L'entrée de l'antenne doit être réglée au niveau optimal où le réglage peut être mis à exécution d'une manière satisfaisante avec la quantité appropriée de bruit contenue dans l'onde de signal (3μV-5μV). Régler FM IFT L105 de sorte que la forme d'onde soit plus grande et contienne le bruit uniformément sur le sommet et le fond de la forme d'onde. (Fig. 3)  
**Note:** Quoique les deux points d'accord soient disponibles, s'assurer de synchroniser dans le point supérieur.
- 4. Répéter les points 2 et 3 jusqu'à ce qu'aucune amélioration additionnelle ne soit plus observée.
- 5. Placer le cadran à la position de 90MHz précisément. Régler la bobine FM OSC L102 pour obtenir le signal de 90MHz du générateur de signal MF, et régler les bobines RF L103 et 101 pour obtenir la sensibilité maximale à 90MHz.
- 6. Ensuite, placer le cadran à 106MHz et commuter la fréquence du générateur de signal MF à 106MHz. Régler le condensateur de réglage FM OSC CT102 pour recevoir le signal de 106MHz, et régler les condensateurs de réglage RF CT103 et 101 pour la sensibilité maximale à 106MHz.
- 7. Répéter les points 5 et 6 jusqu'à ce qu'aucune amélioration additionnelle ne soit plus observée.
- 8. Recevoir le signal de 90MHz (Mod. du 100% de 400 Hz, entrée de 1mV) du générateur de signal MF. Régler l'âme supérieure de FM IFT L109 pour minimiser la distortion.  
Si l'aiguille du compteur à centre zéro s'écarte de la position moyenne après le réglage dans le point 8, régler finement l'âme inférieure de FM IFT L109.
- 9. Recevoir le signal de 90MHz et 1mV du générateur de signal MF de sorte que la LED 2 (vert) s'allume seulement. (L'aiguille du compteur à centre zéro doit tomber sur la position moyenne).  
En maintenant cet état:
  - a) Placer le générateur de signal à une position de 50kHz plus haute que 90MHz, et régler le potentiomètre VR172 de sorte que la LED 1 s'allume légèrement.
  - b) Placer le générateur de signal à une position de 50 kHz plus basse que 90MHz, et régler le potentiomètre VR171 de sorte que la LED 3 s'allume légèrement. Voir la Fig. 3.

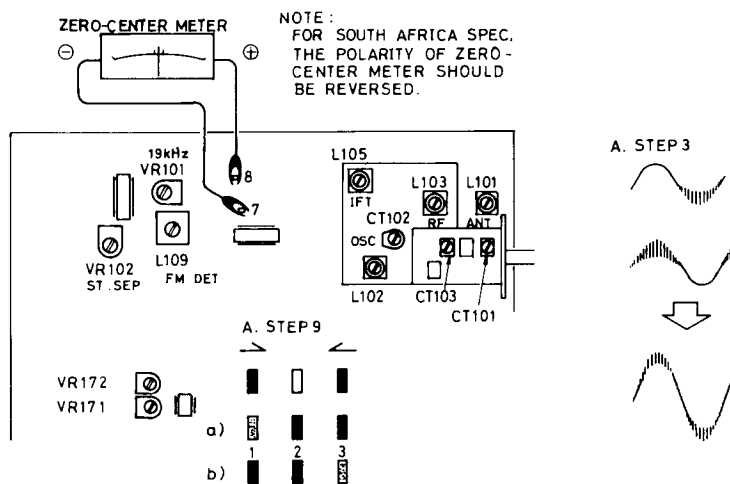

Fig. 3

**B. FM Stereo Adjustment**

**Instruments:** FM Stereo SG, Oscilloscope, AC Voltmeter, MPX Filter Coil (RL-86B).

- Set Function Selector to FM position beforehand.
- 1. Connect Oscilloscope and AC Voltmeter to R-ch OUTPUT through MPX Filter Coil.
- 2. Receive stereo signal from FM Stereo Signal Generator (with antenna input level set at 1mV).  
Pilot tone. . . . .9% mod.  
Audio signal 1,000Hz, L-ch only . . . . .90% mod.  
Turn potentiometer VR101 to the mid-position of the range where Stereo Indicator illuminates.
- 3. Adjust potentiometer VR102 to minimize leakage of signal from L-ch into R-ch.
- 4. Next, connect Oscilloscope and AC Voltmeter to L-ch OUTPUT and switch the modulation of the FM Stereo Signal Generator to R-ch signal. Check to make sure leakage of signal from R-ch into L-ch is almost the same as that from L-ch into R-ch.  
If there is a marked difference, fine-adjust VR102.

**Notes for South African Specs:**

- \*1 Plus lead to pin 7 and minus lead to 8.
- \*2 Adjust potentiometer VR171.
- \*3 Adjust potentiometer VR172.
- For South African specs., Tuning Indicator LEDs 1 and 3 have been connected properly to give correct indication, when supplied.

**B. Réglage stéréophonique MF**

**Instruments:** Générateur de signal stéréophonique MF, oscilloscope, voltmètre à courant alternatif et bobine filtre MPX (RL-86B)

- Placer le sélecteur de fonction à la position FM au préalable.
- 1. Brancher l'oscilloscope et le voltmètre à courant alternatif au OUTPUT au canal droit à travers la bobine filtre MPX.
- 2. Recevoir le signal stéréophonique du générateur de signal stéréophonique MF (niveau d'entrée de l'antenne placé à 1mV).  
Signal d'identification . . . . .9% mod.  
Signal audio 1.000Hz (canal gauche seul) . . 90% mod.  
Tourner le potentiomètre VR101 à la position moyenne de l'étendue où l'indicateur stéréo s'illumine.
- 3. Régler le potentiomètre VR102 pour minimiser la fuite du signal du canal gauche au canal droit.
- 4. Ensuite, brancher l'oscilloscope et le voltmètre à courant alternatif au OUTPUT de canal droit, et commuter la modulation du générateur de signal stéréophonique MF au signal de canal droit. Vérifier pour assurer que la fuite du signal du canal droit au canal gauche est presque la même que cela du canal gauche au canal droit. S'il y a une différence marquée, régler finement le VR102.

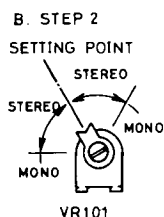

Fig. 4

### C. AM(MW and LW) Alignment

**Instruments:** AM Signal Generator and AC Voltmeter

Input signal must be kept as low as possible to avoid AGC action.

Step	Generator		Tuning Dial Setting	Output Indicator Connected to	Adjust	Adjust for
	Coupling	Frequency				
1	Set Function Selector switch to AM (AM-MW).					
2	Pin No.9 through a 0.01mfd capacitor.	455kHz (400Hz, 30% mod.)	Non interfering at low end of scale.	AC VTVM to OUTPUT.	L202, 203, 204	Maximum reading on AC voltmeter
3	Test Loop Radiate signal into ferrite loopstick antenna.	600kHz (400Hz, 30% mod.)	600kHz		L201 (OSC) and L001 ANT. Coil (MW).	
4		1,400kHz (400Hz, 30% mod.)	1,400kHz		CT202 (OSC) and CT201 (ANT) Trim. (on AM VC).	
5	Repeat steps 3 and 4 until no further improvement is noticed.					
6	Set Function Selector switch to AM-LW.					
7	Same as Step 3	160kHz (100Hz, 30% mod.)	160kHz	Same as Step 2	L252 (OSC) and L001 ANT Coil (LW.)	Same as Step 2
8		320kHz (100Hz, 30% mod.)	320kHz		CT252 (OSC) CT251 (ANT) Trim.	
9	Repeat Steps 7 and 8 until no further improvement is noticed.					

**Note:** Steps 7 through 9 apply to 3-band models (with LW) only.

### C. Alignement MA (PO et GO)

**Instruments:** Générateur de signal MA et voltmètre à courant alternatif

Le signal d'entrée doit être maintenu aussi bas que possible afin d'éviter l'action AGC.

Point	Générateur		Ecran d'accord	Indicateur de sortie connecté à	Réglage	Réglage pour
	Couplage	Fréquence				
1	Régler le commutateur sélecteur de fonction sur AM (AM-MW).					
2	Broche No.9 par l'intermédiaire d'un condensateur de 0,01mfd.	455kHz (400Hz, 30% mod.)	Non interférence à l'extrémité inférieure de l'échelle.	Voltmètre électronique au OUTPUT	L202, 203, 204	Lecture maximum sur le voltmètre à courant alternatif
3	Boucle de mesure Envoie le signal sur l'antenne ferrite à boucle.	600kHz (400Hz, 30% mod.)	600kHz		L201 (OSC) et L001 (PO) ANT. bobine.	
4		1.400kHz (400Hz, 30% mod.)	1.400kHz		CT202 (OSC) et CT201 (ANT) de correction (sur AM VC)	
5	Répéter les points 3 et 4 jusqu'à ce qu'il ne puisse être remarqué d'amélioration supplémentaire.					
6	Régler le commutateur sélecteur de fonction sur AM-LW.					
7	Identique au point 3.	160kHz (100Hz, 30% mod.)	160kHz	Identique au point 2.	L252 (OSC) et L001 ANT (GO) bobine.	Identique au point 2.
8		320kHz (100Hz, 30% mod.)	320kHz		CT252 (OSC) et CT251 (ANT) de correction	
9	Répéter les points 7 et 8 jusqu'à ce qu'il ne puisse être remarqué d'amélioration supplémentaire.					

**Note:** Les points 7 à 9 s'appliquent aux modèles de 3 bandes (avec GO) seulement.

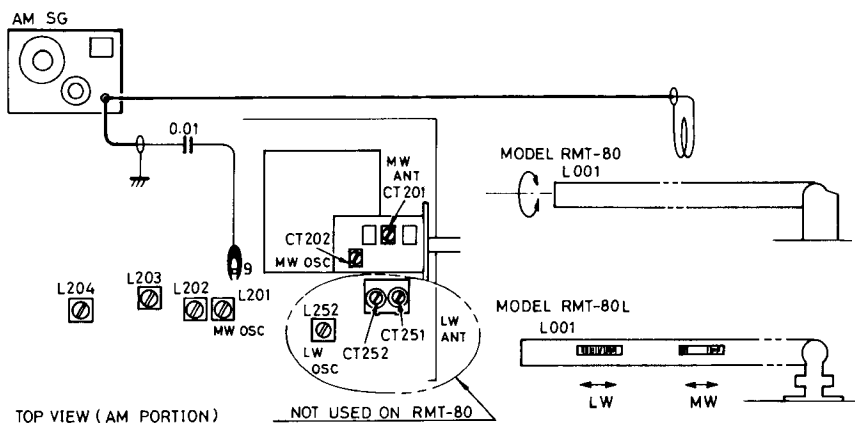
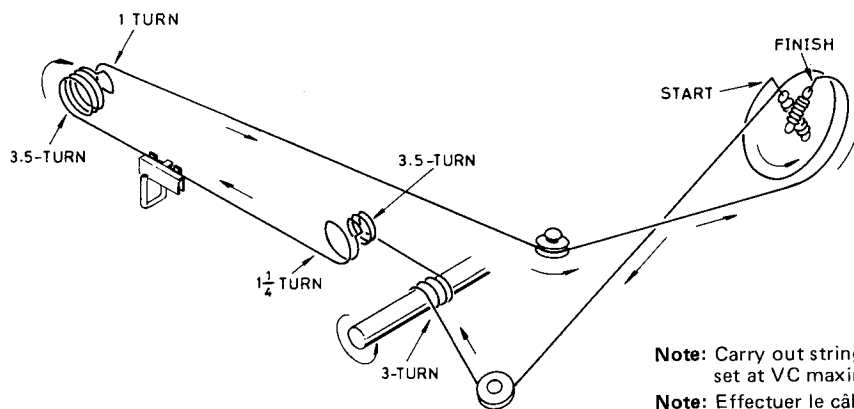

Fig. 5

## Dial Stringing Diagram Diagramme des câbles d'entraînement

### RMT-80/80L



**Note:** Carry out stringing with the front end set at VC maximum.

**Note:** Effectuer le câblage avec le condensateur réglable de l'étage d'entrée réglé au maximum.

## RMD-80

Heads . . . . .	High B Permalloy Laminated (REC/PB) Ferrite Core (ERASE)
Track . . . . .	4-track/2-channel
Tape Speed . . . . .	4.8cm/sec.
Motor . . . . .	Electronic DC Governor
Wow and Flutter . . . . .	0.15% (DIN) 0.05% (WRMS)
Distortion (REC/PB, 400Hz) . . . . .	0.6% (METAL)
Frequency Response:	
Normal, LH . . . . .	.30 to 14,000Hz±3dB
Chromium . . . . .	.30 to 15,000Hz±3dB
FeCr . . . . .	.30 to 16,000Hz±3dB
Metal . . . . .	.30 to 17,000Hz±3dB
Signal-to-Noise Ratio (Chromium) . . . . .	Dolby NR in: 64dB Dolby NR out: 55dB
Input Sensitivity/Impedance:	
MIC. . . . .	.0.3mV/10 kohms
LINE . . . . .	.40mV/47 kohms

Output Level . . . . .	.580mV/1 kohms	
Fast Wind Time (C-60) . . . . .	.90 seconds	
Tape Selector . . . . .	BIAS	EQUALIZER
Normal, LH . . . . .	100%	120µs
Chromium . . . . .	150%	70µs
FeCr . . . . .	110%	70µs
Metal . . . . .	200%	70µs

### MISCELLANEOUS

- Power Requirement . . . . . Power supplied from the amplifier RMA-80.
- Specifications and design subject to possible modification without notice.
  - Dolby, Dolbyzed and the double-D symbol are trade marks of Dolby Laboratories.  
Noise reduction system manufactured under license from Dolby Laboratories.

## RMA-80

Continuous Power Output . . . . .	.25 watts* per channel, min. RMS both channels driven into 8 ohms from 20 to 20,000Hz with no more than 0.08% total harmonic distor- tion.
Total Harmonic Distortion . . . . . (20 to 20,000Hz, from AUX)	No more than 0.08% (conti- nuous rated power output) No more than 0.08% (conti- nuous 1/2 watt power output) No more than 0.09% (1 watt per channel power output, 8 ohms)
Intermodulation Distortion . . . . . (60Hz : 7kHz = 4 : 1)	No more than 0.05% (conti- nuous rated power output) No more than 0.04% (conti- nuous 1/2 watt power output) No more than 0.04% (1 watt per channel power output, 8 ohms)
Damping Factor . . . . .	.35 (20 to 20,000Hz, 8 ohms)
Output: Speaker . . . . .	.8-16 ohms
Headphone . . . . .	.8-16 ohms
Input Sensitivity/Impedance:	
PHONO . . . . .	.2.5mV/47 kohms
TUNER . . . . .	.150mV/42 kohms
TAPE IN . . . . .	.150mV/42 kohms

Overload Level (T.H.D. 0.1% 1kHz):	
PHONO . . . . .	.185mV
TUNER . . . . .	.Not less than 5V
Frequency Response:	
PHONO . . . . .	.30 to 15,000Hz ±0.5dB (RIAA STD)
TUNER, TAPE IN . . . . .	.5 to 70,000Hz, +0dB, -1.0dB
Tone Control:	
BASS . . . . .	.±10dB (50Hz)
TREBLE . . . . .	.±10dB (15kHz)
Loudness Contour . . . . .	.+10dB (100Hz), +4dB (10kHz) (volume control set at -40dB position)
Signal-to-Noise Ratio (IHF, A network):	
PHONO . . . . .	.75dB
TUNER, TAPE IN . . . . .	.95dB
Power Requirement . . . . .	.120V/60Hz, 220V/50Hz, 240V/50Hz 120, 220, 240V/50-60Hz
Power Consumption . . . . .	.150 watts

- Specifications and design subject to possible modification without notice.
- \*Measured pursuant to the Federal Trade Commission's Trade Regulation Rule on Power Claims for Amplifiers (applicable to the U.S.A. only).

## RMT-80/-80L

### FM SECTION

Usable Sensitivity: Mono . . . . .	.11.2dBf (2.0µV/300 ohms)
Stereo . . . . .	.20.0dBf (5.5µV/300 ohms)
50dB Quieting Sensitivity:	
Mono . . . . .	.15.2dBf (3.2µV/300 ohms)
Stereo . . . . .	.36.0dBf (35µV/300 ohms)
Signal-to-Noise Ratio (at 65dBf):	
Mono . . . . .	.75dB
Stereo . . . . .	.65dB
Distortion (at 65dBf):	
100Hz . . . . .	.0.1% (mono), 0.25% (stereo)
1kHz . . . . .	.0.1% (mono), 0.25% (stereo)
6kHz . . . . .	.0.2% (mono), 0.35% (stereo)
Frequency Response . . . . .	.30 to 15,000Hz +1.0dB, -1.5dB
Capture Ratio . . . . .	.1.0dB
Alternate Channel Selectivity . . . . .	.60dB
Spurious Response Ratio . . . . .	.70dB
Image Response Ratio . . . . .	.40dB
IF Response Ratio . . . . .	.75dB
AM Suppression Ratio . . . . .	.55dB

Stereo Separation . . . . .	.45dB (1kHz), 35dB (30 to 15,000Hz)
Subcarrier Product Ratio . . . . .	.45dB
SCA Rejection Ratio . . . . .	.70dB
Antenna Input . . . . .	.300 ohms balanced, 75 ohms unbalanced

### AM SECTION

Sensitivity: MW . . . . .	.200µV/m (IHF, ferrite antenna)
LW . . . . .	.600µV/m (RMT-80L)
Selectivity . . . . .	.35dB
Signal-to-Noise Ratio . . . . .	.50dB
Image Response Ratio . . . . .	.50dB
IF Response Ratio . . . . .	.40dB
Antenna . . . . .	.Built-in ferrite loopstick antenna

### MISCELLANEOUS

- Power Requirement . . . . . Power supplied from the amplifier RMA-80.
- Specifications and design subject to possible modification without prior notice.

## Repair Parts List

## Liste des pièces de rechange

# RMD-80

Schematic Location	Description	Part No.	Schematic Location	Description	Part No.
<b>TRANSISTORS, DIODES AND IC'S</b>				Bias OSC and Level Ind Driver PCB Ass'y	141811133
Q101 to 104	2SC2634 (S, T), PB/MIC Amp	301201222		Level Ind PCB Ass'y for L-ch	141811134
Q105, 106	2SA564A (R, S), Rec Amp	301001132		Level Ind PCB Ass'y for R-ch	141811135
Q107, 108, 401 } 402	2SC1684 (R, S), Rec Amp, Shut-off	301201209		Connector, 13P	628111180
Q901	2SC1913 (Q, R), Stabilizer	301201199		Socket Ass'y, LED	648211265
Q902	2SC2590 (R, S), Bias OSC	301201223		Connector, 6P	628111173
D401	MA150	300111016		Holder, LED, (6)	114902322
D402	2P05M, Thyristor	300515003		Holder, LED, (9-3)	114902353
D701, 702, 001	LN324GP, LED (GRN)	300414040		Cord Stopper, Signal	675201114
D703, 704, 705 } 002	LN224RP, LED (RED)	300414042		Cord Stopper, Power Supply	675201116
D901	WZ-210, Zener, 21V, 0.5W	300313007		Signal Cord Ass'y	791001153
D902	RB-152, Rectifier	300919038		Power Supply Cord w/4P Plug	791001154
IC101, 102	LM1011AN, Dolby NR System	303452254		Front Panel Ass'y	111911540
IC401	DN6839, Hall IC, Stop Sensor	303452217		Cassette Lid	114902325
IC901, 902	LB1416, Indicator Driver	303452232		Panel, Cassette Lid	114902353
<b>COILS AND TRANSFORMER</b>				Bottom Cover, Cassette Mech	114902324
L101, 102	Low Pass Filter	228641181		Top Cover	138011315
L103, 104	Bias Trap	228641182		Knob, Rec Level Cont, R-ch	116310326
L105, to 108	Choke, 12mH	228641184		Knob, Rec Level Cont, L-ch	116310328
L901	Choke, 560 $\mu$ H	228641185		Bush, Top Cover	672200884
L902	Bias OSC Trans	228641183		Push Button Ass'y,	
<b>VARIABLE RESISTORS</b>				Tape Selector, etc.	116210083
VR101, 102	100KB, PB Level Cal	510502197		Push Button Ass'y, Dolby NR	116210090
VR103, 104	10KB, Rec Level Cal	510502186		Piano Key, Cassette Control	116210075
VR105, 106	50KB, Bias Adj	510502194		Spring, Tension	658601133
VR301	50KA x 2, Rec Level Control	525101172		String, Tension, L=300mm	787121130
<b>SWITCHES</b>				Screws:	
S101	Slide, Rec/PB	613000036		M3 x 6 (Ni), Bind	705213006
S201	Push 1-key, Dolby NR	614010149		M2.6 x 4 (Ni), Bind	705212604
S301	Push 4-key, Tape Selector	614040833		M3 x 10 (Ni), Bind	705213010
S401	Reed Switch, Stop Sensor	615212262		M3 x 8 (BLZ), Bind	705223008
S501	Push 1-key, Power (Standby)	614010150		M3 x 6 (Ni), Oval-countersunk	702213006
<b>OTHERS</b>				3 x 6 (Ni), TP, Oval-countersunk	722213006
J101, 102	MIC Jack	626110036		3 x 8 (Ni), TP	726213008
	Cassette Mech Ass'y	900111035		3 x 8 (Ni), Tap-tight	765213008
	Rec/PB Amp PCB Ass'y	141811127		3 x 8 (BLZ), TP	726223008
	Tape Selector & Dolby NR SW			3 x 12 (Ni), TP	726213012
	PCB Ass'y (incl. X-377 Ass'y			3 x 8 (Ni), TP, Oval-countersunk	722213008
	X-380 Ass'y & X-382 Ass'y)	141811105		M3 x 9 (Ni), Pulley Mtg	770911130
	Auto Shut-off PCB Ass'y	141811122		M3 x 17, Ornamental Cassette Lid	770911280
				Stopper, MIC Jack	770911278
				Nut, M3, Square	770911144
				Nut, M3, Hex	770402201
				Nut, M9, Hex	770402207
				Washer, Plain, M3	770500003
				Washer, Spring, M3	770500010
				Collar, Indication, Tr. Mtg	992001111

Parts listed in the disassembly diagram are excluded.



# RMA-80

Schematic Location	Description	Part No.	Schematic Location	Description	Part No.
<b>DIODES AND IC'S</b>					
D601	RB-152, Rectifier	300919038		Phono Amp Circuit PCB Ass'y	141510180
D602, 603	SR1K-4, Rectifier	300919024		Tone Amp and Power Supply PCB Ass'y	
D604, 605	BZ-192, Zener, 19.2V, 1W	300313022		w/Volume Control PCB Ass'y	141710335
D606, 607	WZ-140, Zener, 14V, 0.5W	300313018		Power Amplifier PCB Ass'y	141610347
D701	WZ-063, Zener, 6.2V, 0.5W	300313038		Level Indicator PCB Ass'y	141811142
D801	BZ-090, Zener, 9V, 1W	300313042		Level Ind Driver PCB Ass'y	141811143
D802, 803	1K188	300111008		Fuse PCB Ass'y, 120V Area	141811144
D901 to 906	LN224RP, LED, Level Ind	300414042		Fuse PCB Ass'y, Europe, UK	141811145
IC401, 402	HA1457W-02, Phono Amp	303452192		Push Terminal, 4P, Speaker	642400115
IC501	NJM4558DD, Tone Amp	303452152		Fuse Holder, 2P, Long	648211157
IC701	SI-1125HD, Power Amp	303452185		Fuse Holder, 2P, Midget	648211162
IC801	LB1416, Level Ind Driver	303452232		Socket, 4P, Power Supply	648211212
<b>COILS AND TRANSFORMERS</b>				Pin Jack, 4P, Inputs	624200204
L701, 702	Anti-parasitic Coil	228641105		Phone Jack	626110036
T001	Power Transformer			Holder, LED, (6)	114902332
	T-132G (Toroidal Type),			Connector, 8P, Type S	628111175
	120V Area, S. Africa	207001510		Fuse Holder, 2P, Long, PCB Mounting	648211259
	T-132E (Toroidal Type),			Fuse Holder, 1P, Long, PCB Mounting	648211260
	Europe, UK	206001510		Fuse Holder, 2P, Midget, PCB Mounting	648211266
	T-143E (2L-Type), Europe,			Fuse Holder, 1P, Midget, PCB Mounting	648211267
	UK	206001519		Voltage Selector*	648211247
<b>VARIABLE RESISTORS</b>				Power Supply Cord, (U.S.A., etc.)	796301115
VR501	250KW, Balance Control	515121130		Power Supply Cord, (UK, S.A.)	796301138
VR502	100KBT x 2, Volume Control	525121149		Power Supply Cord, (Australia)	796301140
VR503, 504	100KC x 2, Bass, Treble			Power Supply Cord, (Europe)	796301148
	Controls	525101166		Cord Stopper, (not for UK, S.A.)	675201114
<b>SWITCHES</b>				Cord Stopper, (for UK, S.A.)	675201116
S1, 2, 3 (1 set)	Push, 4-key, Function,			Foot	673402021
	Loudness, etc.	614040835		Front Panel Ass'y	111911546
S4	Push, 1-key, Power, 120V Area	614010139		Top Cover	138011317
	" " Europe, UK	614010138		Knob, Balance, etc.	116310304
<b>OTHERS</b>				Knob, Volume Control	116310332
C001	Noise Canceller for 120V Area	470101118		Push Button, Function, etc.	116210083
	Noise Canceller for Europe, UK	470101122		Push Button, Loudness	116210090
F301	2.5A (120V Area)	341222250		Screws:	
	T1.25A (Europe, UK)	345952125		M3 x 6 (Ni), Oval-countersunk, Push	
F302, 303	3.5A (120V Area)	341222350		SW Mtg, etc.	702213006
	T3.15A (Europe, UK)	345952315		M4 x 8 (Ni), ⊕, Bind, GND	705014008
F304	1A (120V Area)	341222100		M3 x 8 (BLZ), Bind, Fuse Cover Mtg	705223008
	T1.25A (Europe, UK)	345952125		M3 x 6 (Ni), Bind, PCB Mtg, etc.	705213006
F305	0.5A (120V Area)	341222050		M3 x 15 (Ni), Bind, Power IC Mtg	705213015
	T500mA (Europe, UK)	345952050		M3 x 4 (Ni), Bind, Fuse PCB Mtg	705213004
F001, 002	3A (120V Area)	341222300		3 x 8 (Ni), TP	726213008
	3.15A (Europe, UK)	345252315		3 x 8 (BLZ), Top Cover Mtg, etc.	726223008
				3 x 12 (Ni), TP, Foot Mtg	726213012
				4 x 8 (Ni), TP, Bind, Trans Mtg	725214008
				3 x 6 (Ni), TP, Countersunk, Panel Mtg	721213006
				Insert Screw, Fuse Mtg	770911133
				Nut, M7, Hex	770402205
				Washer, M7	770500006
				Washer, M4	770500004
				Stopper, Jack Mtg	770911278

\*Not used for Europe and UK.

# RMT-80/-80L

Schematic Location	Description	Part No.
<b>TRANSISTORS, DIODES AND IC'S</b>		
Q101	2SK168 (F), FMRF Amp	302001122
Q102, 103	2SC1674 (K, L), FM OSC, Mix	301201163
Q104, 201, 202 203, 251*	2SC829 (C), FM IF Amp, AM Conv, etc.	301201117
Q105, 106, 107	2SC1684 (R, S), FM MPX, etc.	301201209
Q108, 109, 204 205	2SC2634 (S, T), FM Audio Amp, AM Audio Amp, etc.	301201222
Q171	2SA921 (S, T), FM Tuning Ind Driver	301001145
Q401	2SC1826 (O, Y), Stabilizer	301201169
D101, 102, 103 201, 204, 205	1K188, FM AGC, AM Det, etc.	300111008
D171, 172, 202 203, 251*	MA150	300111016
D301, 302, 304	LN224RP, LED (Red), FM Stereo Ind, etc.	300414042
D303	LN324GP, LED (GRN), Tuning Ind	300414040
D401	WZ-162, Zener, 16.2V, 0.5W	300313017
IC101	HA1137W, FM Det	303452156
IC102	AN363N, FM MPX Dec	303452197
IC171	NJM4558D, Indicator Driver	303452215
<b>COILS</b>		
L101	FM Ant	226501153
L102	FM OSC, (STD) FM OSC, (South Africa only)	226501160 226501162
L103	FM RF	226501154
L104	Choke, 2.2 $\mu$ H	226501143
L105	FM IFT	225501131
L107	Choke, 18 $\mu$ H, Phase Shifter	226501152
L108, 205, 401	Choke, 47 $\mu$ H	226501123
L109	FM IFT, Det	225501132
L201	MW OSC	223301124
L202	AM IFT, 1st	225301125
L203	AM IFT, 2nd	225301126
L204	AM IFT, 3rd	225301127
L251*	Bandpass Filter	228641120
L252*	LW OSC	223301129
L001	AM Antenna, for RMT-80 only AM Antenna, for RMT-80L only	222391150 222391149
<b>VARIABLE RESISTORS</b>		
VR101	5KB, MPX 19kHz Adj	510502140
VR102	50KB, Stereo Separation Adj	510502142
VR171, 172	10KB, FM Tuning Ind Adj	510502186
<b>OTHERS</b>		
CT102	10pF max, Trimmer, FM OSC Adj	490110124
CT251*, 252*	15pF max x 2, Trimmer, LW OSC, LW RF Adj	490110113
S1, 2, 3 (1 set)	Push 3-key, Function and FM Muting/Mode, for RMT-80 " for RMT-80L	614030840 614030841
S4	Push 1-key, Standby	614010150

Schematic Location	Description	Part No.
PL001	Lamp, 8V, 150mA, Dial Light	359101127
	PCB Ass'y for RMT-80 (STD)	141311401
	" for RMT-80 (S. Africa)	141311403
	" for RMT-80L	141311404
	Variable Capacitor, AM/FM	322420019
X101, 102	Ceramic Filter, FM IF, 10.7MHz	229101171
X201	Ceramic Filter, AM IF, 455kHz	229101205
	Connector Socket, 8P	628111175
	LED Holder, 6P	114902322
	Antenna Terminal Strip, 4P	649201115
	Coaxial FM Ant Socket*	628111166
	Signal Cord Ass'y	791001153
	Power Supply Cord Ass'y	791001154
	Rubber Bush, Lamp Mtg	672200813
	Cord Stopper, Signal Cord Mtg	675201114
	Cord Stopper, Power Cord Mtg	675201116
	Bush, Top Cover	672200884
	Foot	673402021
	Shaft Ass'y, Tuning	654911299
	Dial Drum	651300013
	Pulley	651110022
	String, Dial, L=1.4m	787121131
	Spring, Dial String	658601121
	Front Panel Ass'y for RMT-80	111911542
	Front Panel Ass'y for RMT-80L	111911544
	Top Cover	138011316
	Dial Pointer	151691150
	Dial Board, for RMT-80 (STD)	112011387
	" , for RMT-80 (S. Africa only)	112011390
	" , for RMT-80L	112011388
	Knob, Tuning	116310330
	Push Button Ass'y, Power, etc.	116210083
	" , Muting	116210090
Screws:		
	M3 x 6 (Ni), Oval-countersunk, Power SW Mtg	702213006
	M2.6 x 4 (BLZ)*, Pan Head, Coaxial Socket Mtg	703222604
	M2.6 x 8 (BLZ), Bind Head, Dial Board Mtg	705222608
	3 x 8 (Ni), TP, PCB Mtg, etc.	726213008
	3 x 12 (Ni), TP, Foot Mtg	726213012
	3 x 8 (BLZ), TP, Ant Terminal Mtg, etc.	726223008
	3 x 6 (Ni), TP, Oval-countersunk	722213006
	3 x 6 (Ni), TP, Countersunk, Front Panel Mtg	721213006
	M3 x 9 (Ni), Pulley Mtg	770911130
	M3 x 13 (Ni), W-pulley Mtg	770911131
	Nut, M9, Hex, T-Shaft Mtg	770402207

\* Used for RMT-80L only.

# Chassis Layout (Top View)

## Installation du châssis (vue de dessus)

### RMD-80

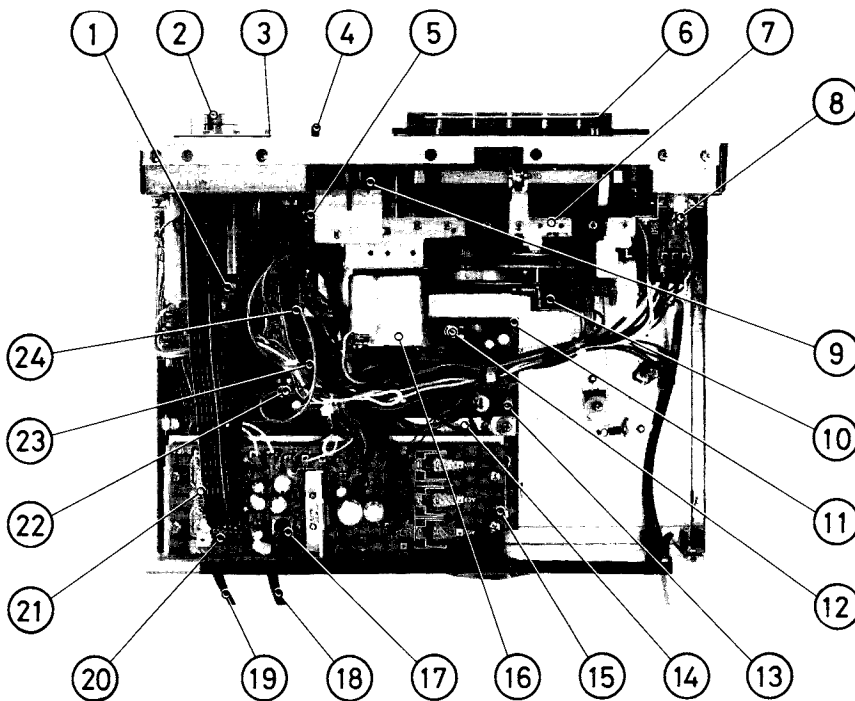

1. TAPE SELECTOR PCB (X-375)
2. RECORDING LEVEL CONTROL
3. TAPE SELECTOR
4. COUNTER RESET BUTTON
5. AUTO SHUT-OFF PCB (X-386 or X-413)
6. MECHANISM CONTROL KEYS
7. CASSETTE MECH
8. STANDBY SWITCH
9. TAPE COUNTER
10. PLUNGER SOLENOID
11. REC/PB AMP PCB (X-374)
12. VR102, PB LEVEL CAL, R-CH
13. VR106, BIAS ADJ, R-CH
14. S101, REC/PB SWITCH
15. RECT/BIAS OSC/LEVEL IND DRIVER PCB (B-154)
16. MOTOR
17. BIAS OSC TRANS
18. LINE OUT CORD
19. LINE IN CORD
20. LEVEL IND DRIVER IC, R-CH
21. LEVEL IND DRIVER IC, L-CH
22. VR103, REC LEVEL CAL, L-CH
23. VR104, REC LEVEL CAL, R-CH
24. DOLBY\* NR SWITCH PCB (X-376)

\*Dolby and Dolbized are trademarks of Dolby Laboratories.  
Noise reduction system manufactured under license from Dolby Laboratories.

### RMA-80

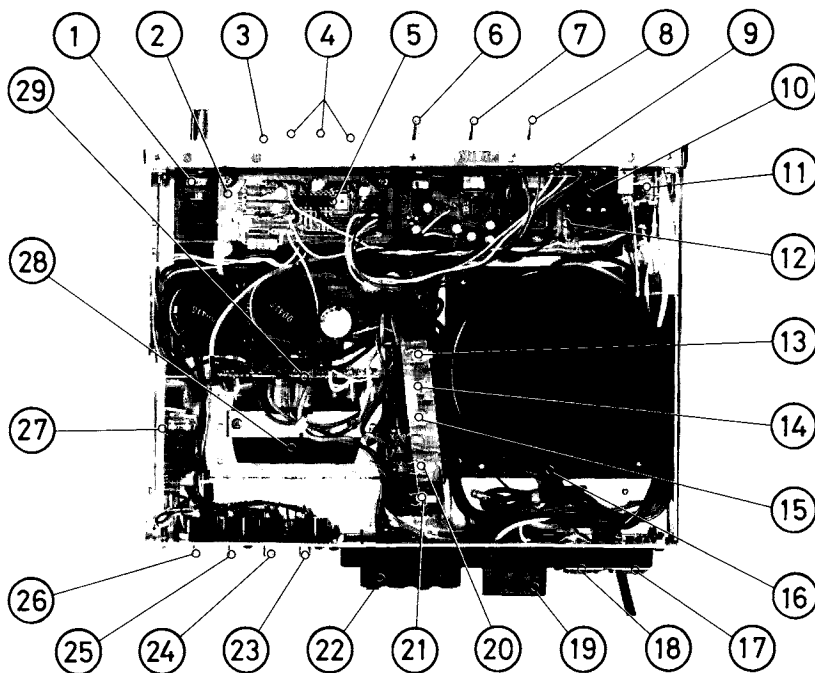

1. VOLUME CONTROL
2. LEVEL IND DRIVER PCB (X-391)
3. LOUDNESS SWITCH
4. FUNCTION SWITCH
5. IND DRIVER IC
6. BALANCE CONTROL
7. TREBLE CONTROL
8. BASS CONTROL
9. LEVEL INDICATOR PCB
10. PHONE JACK
11. POWER SWITCH
12. TONE AMP & POWER SUPPLY PCB (TC-157)
13. F305, FUSE
14. F304, FUSE
15. F303, FUSE
16. POWER TRANSFORMER\*
17. POWER SUPPLY SOCKET
18. POWER SUPPLY SOCKET
19. SPEAKER FUSE
20. F302, FUSE
21. F301, FUSE
22. SPEAKER TERMINAL
23. TAPE OUT JACKS
24. TAPE IN JACKS
25. TUNER JACKS
26. PHONO JACKS
27. PHONO AMP PCB (PR-121)
28. POWER AMP IC
29. POWER AMP PCB (AF-117)

\* The photo shows toroidal type.  
Units incorporating 2L (square) type are also supplied.

# RMT-80/-80L

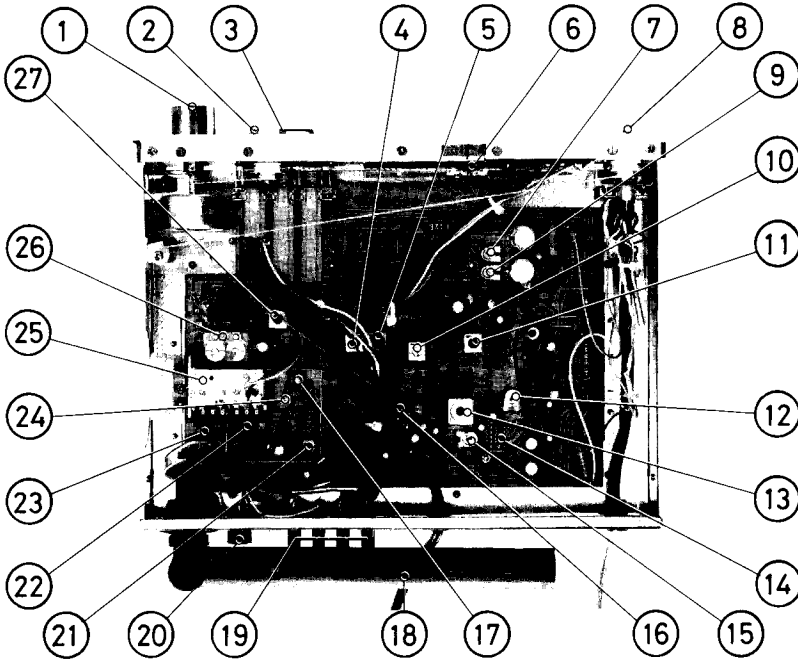

1. TUNING KNOB
2. MUTING/MODE SWITCH
3. FUNCTION SWITCH
4. L201, MW OSC COIL
5. L202, AM IFT, 1st
6. DIAL POINTER
7. VR171, FM TUNING IND ADJ
8. STANDBY SWITCH
9. VR172, FM TUNING IND ADJ
10. L203, AM IFT, 2nd
11. L204, AM IFT, DET
12. VR102, FM STEREO SEPARATION ADJ
13. L109, FM IFT, DET
14. IC102, MPX DEC
15. VR101, 19kHz ADJ
16. IC101, FM IF AMP
17. L102, FM OSC COIL
18. L001, AM ANT COIL
19. ANTENNA TERMINAL STRIP
20. FM 75-OHM ANTENNA SOCKET\*
21. L105, FM IFT, 1st
22. L103, FM RF COIL
23. L101, FM ANT COIL
24. CT102, FM OSC TRIMMER CAP
25. VARIABLE CAPACITOR, AM/FM
26. CT251, 252, LW ANT/OSC TRIMMER CAP\*
27. L251, LW OSC COIL \*

\*Used for 3-band model (RMT-80L) only.

Note: The photo shows Model RMT-80L. Model RMT-80 is slightly different from the photo.

# Schematic Diagram

# Diagramme schématique

# RMD-80

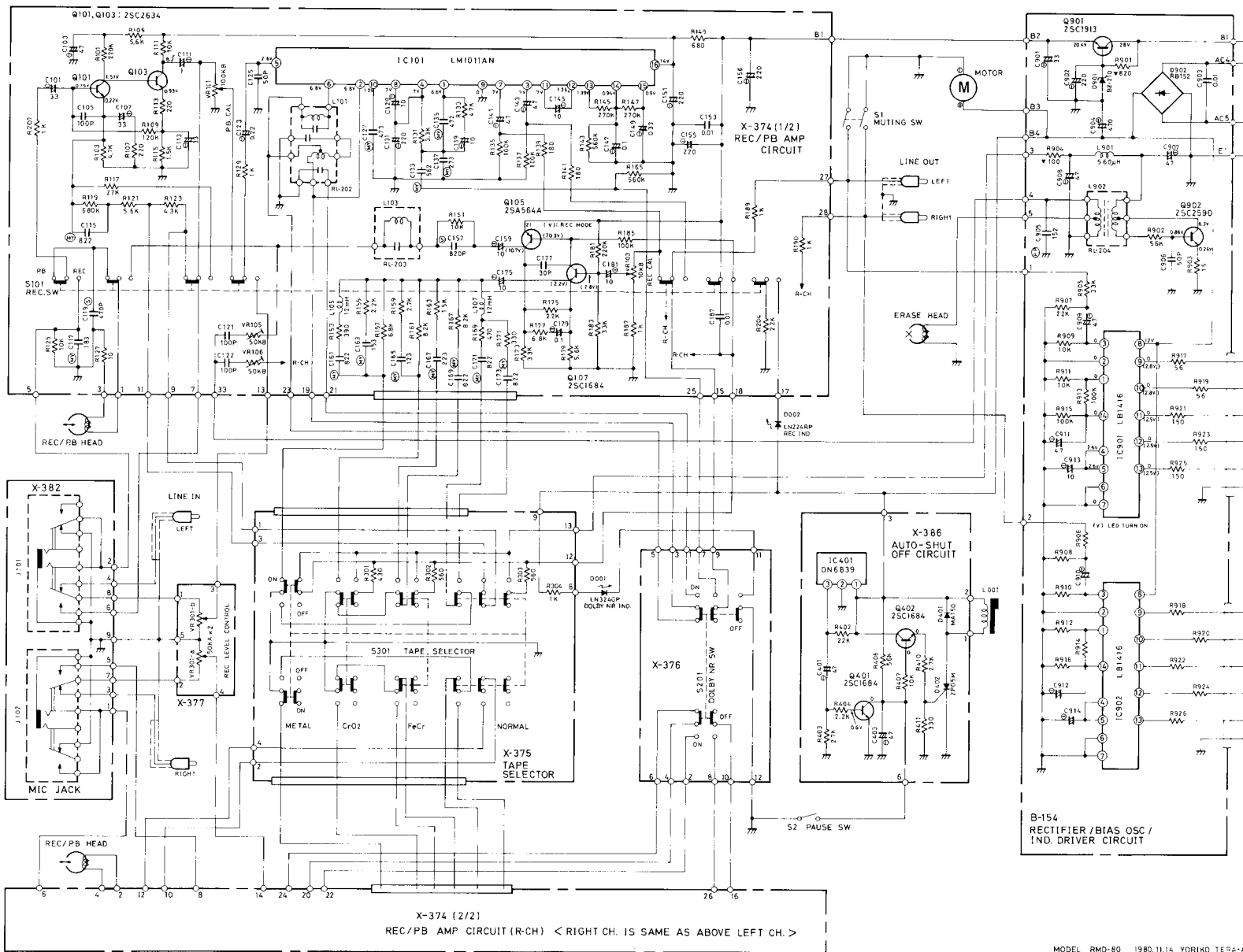

MODEL RMD-80 1980.11.14 YORIKO TER2-A



2SC1684  
2SC2634  
2SA564A

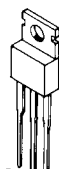

2SC1913

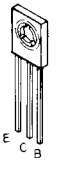

2SC2590

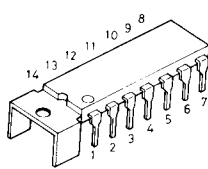

LB1416

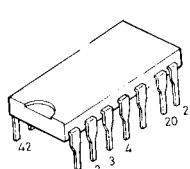

LM1011AN

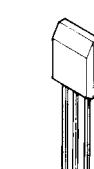

IN 12  
GND 3  
OUT  
DN6839

### RESISTORS

Unless otherwise specified, tolerance is 5%.

K . . . . . Kilohm

M . . . . . Megohm

▼ . . . . . Uninflamable carbon film resistor, 1/2 watt

Non mark . . . Low noise type carbon resistor, 1/4 watt

### CAPACITORS

S . . . . . Polystyrene film capacitor

MY . . . . . Mylar film capacitor

LN . . . . . Low noise type capacitor

PP . . . . . Polypropylene film capacitor

⊘ . . . . . Electrolytic capacitor

Non mark . . . Ceramic capacitor

- Unless otherwise specified, all capacitance values are expressed in MFD.
- Voltage read with VTVM across the point shown and the chassis ground (line voltage: 120V)
- Voltage reading tolerance: ±20%

# RMA-80

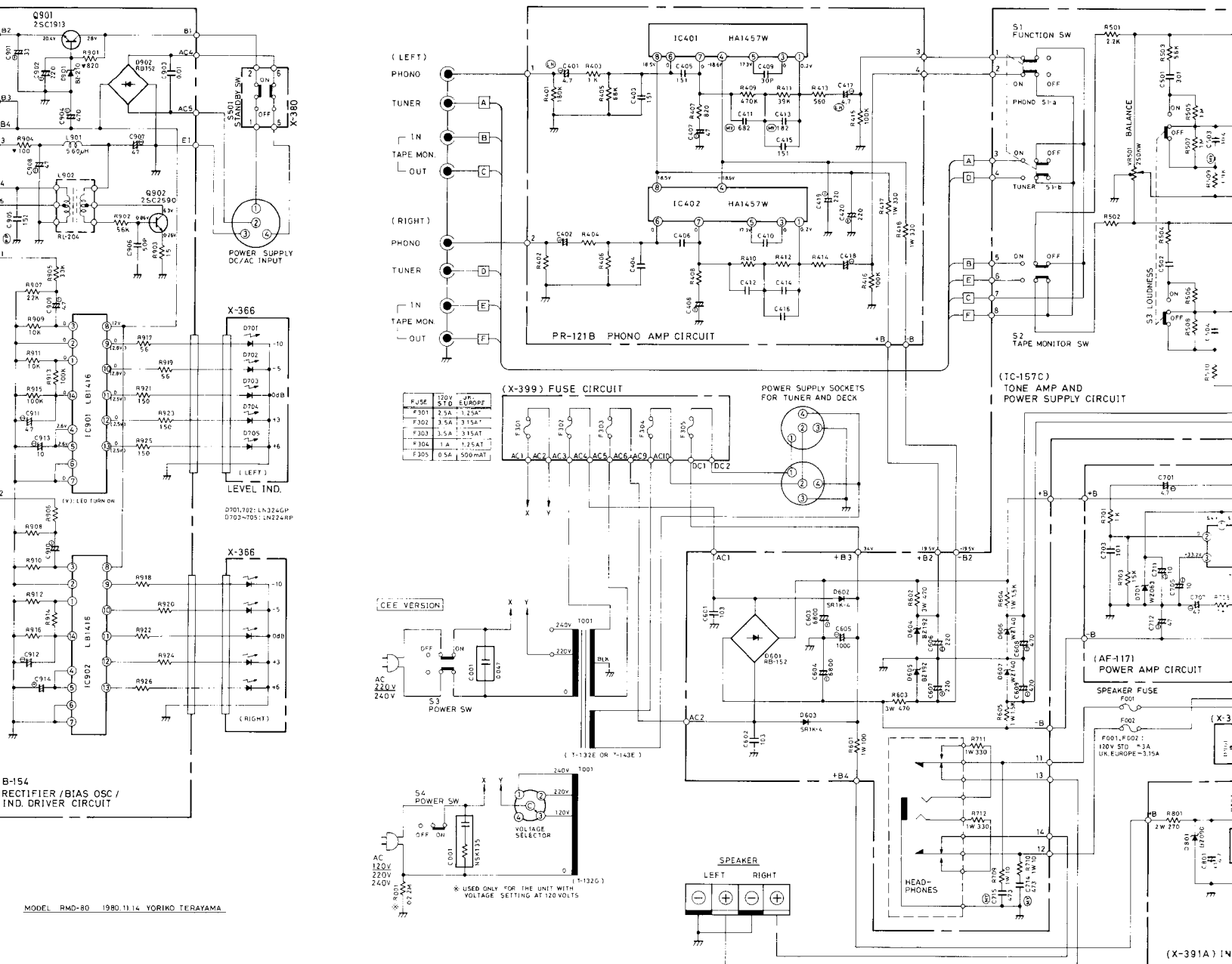

## MODIFICATION:

Capacitors C709 and C710 on Power Amp Circuit have been modified from 100mfd type to 220mfd. (Reason: To prevent possible breakdown of Power IC due to shocks when power is turned on or Function Selector is switched.) This modification is applicable to the units with serial number beginning ND 65868.

The related circuit diagrams in this manual are drawn on the basis of new circuitry.

## RESISTORS

Unless otherwise specified, tolerance is 5%.

K . . . . . Kilohm

M . . . . . Megohm

◇ . . . . . Composition carbon resistor, 1/2 watts

Non mark . . . Low noise type carbon resistor, 1/4 watts

## CAPACITORS

MY . . . . . Mylar film capacitor

LN . . . . . Low noise type capacitor

⊘ . . . . . Electrolytic capacitor

Non mark . . . Ceramic capacitor

- Unless otherwise specified, all capacitance values are expressed in MFD.
- Voltage read with VTVM across the point shown and the chassis ground (line voltage: 120V)
- Voltage reading tolerance: ±20%

# RMT-80/80L

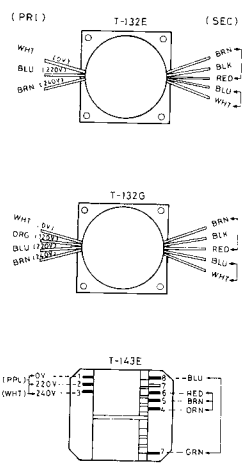
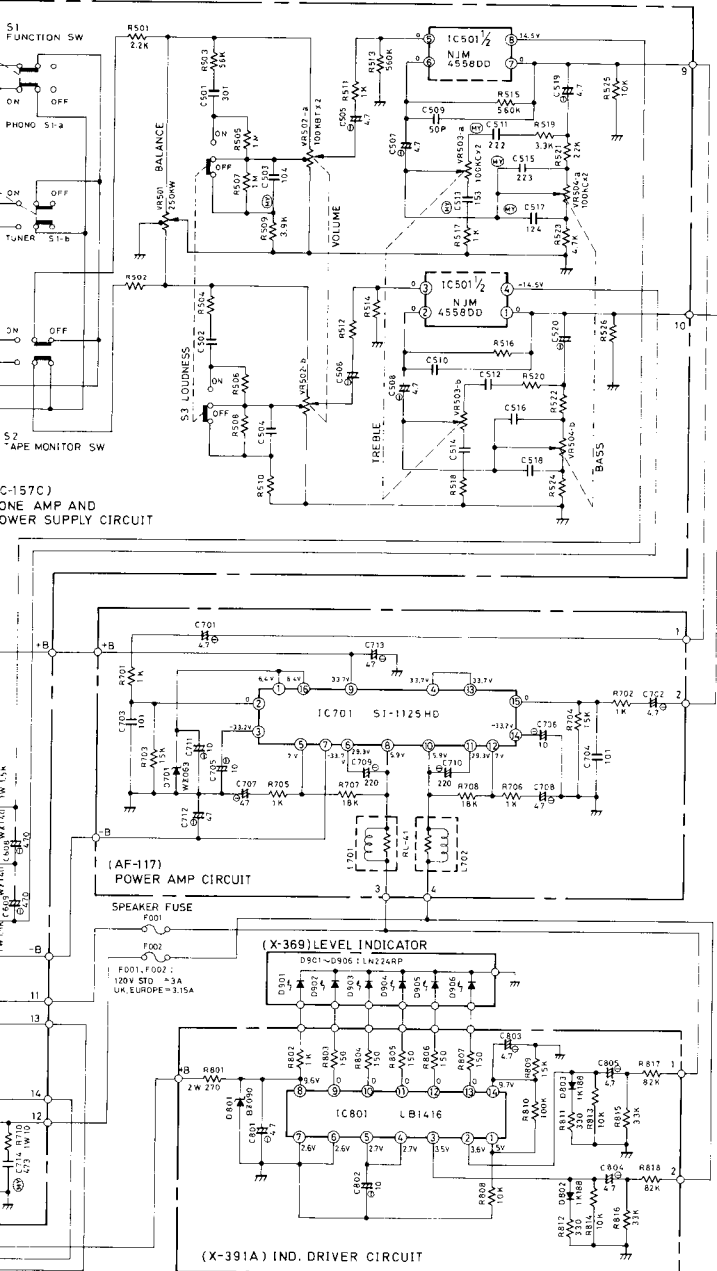

MODEL : RMA-80  
55.10.23 TERAYAMA

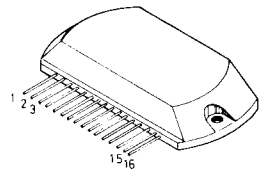
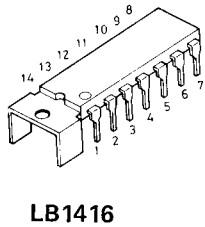
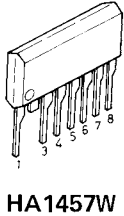
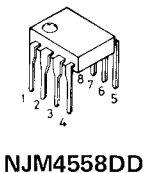
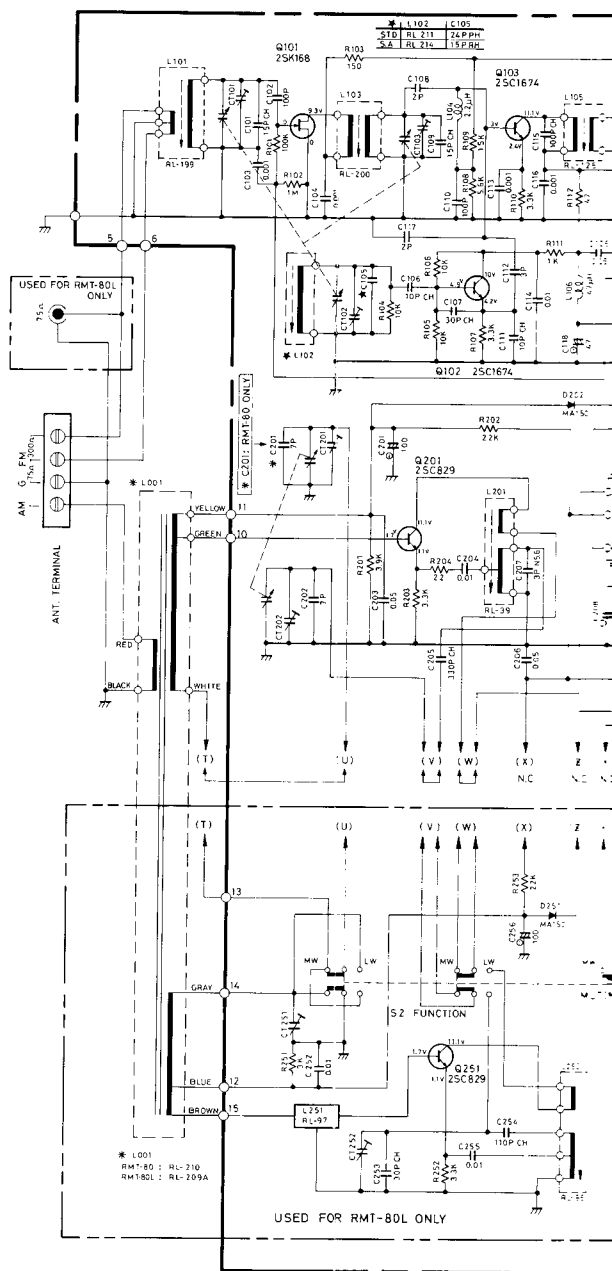

## RESISTORS

Unless otherwise specified, tolerance  
 K . . . . .Kilohm  
 M . . . . .Megohm  
 ▽ . . . . .Uninflamable carbon  
 Non mark . . .Low noise type carbon

## CAPACITORS

S . . . . .Polystyrene film capacitor  
 MY . . . . .Mylar film capacitor  
 . . . . .Electrolytic capacitor  
 Non mark . . .Ceramic capacitor

- Unless otherwise specified, all capacitance values are expressed in MFD.
- Voltage read with VTVM across the component and the chassis ground (line voltage: 120V).
- Voltage reading tolerance: ±20%

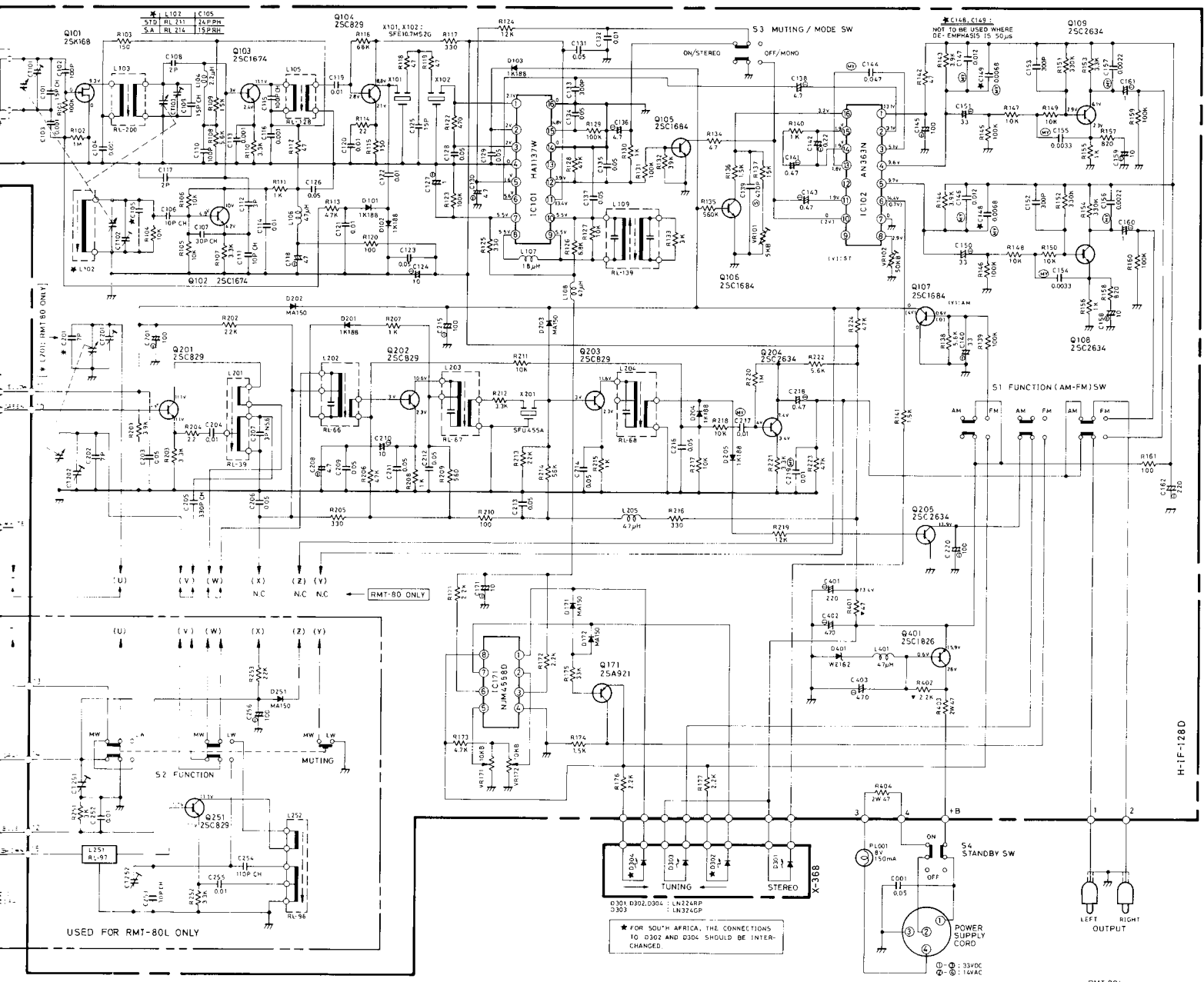

### RESISTORS

Unless otherwise specified, tolerance is 5%.

- K . . . . .Kilohm
- M . . . . .Megohm
- ▼ . . . . .Uninflamable carbon film resistor, 1/2 watt
- Non mark . . .Low noise type carbon resistor, 1/4 watt

### CAPACITORS

- S . . . . .Polystyrene film capacitor
- MY . . . . .Mylar film capacitor
- |— . . . . .Electrolytic capacitor
- Non mark . . .Ceramic capacitor

- Unless otherwise specified, all capacitance values are expressed in MFD.
- Voltage read with VTVM across the point shown and the chassis ground (line voltage: 120V)
- Voltage reading tolerance: ±20%

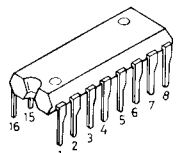
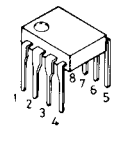

2SC829  
2SA921  
2SC1674  
2SC1684  
2SC2634  
2SA564A

2SC1826

NJM4558D

2SK168

AN363N  
HA1137W

\* FOR SOUTH AFRICA, THE CONNECTIONS TO D302 AND D304 SHOULD BE INTERCHANGED

RMT-80L  
MODEL: RMT-80 55.10.23 TERAYAMA



# RMD-80

## REC/PB AMP CIRCUIT CIRCUIT D'AMPLI ENREGIST/LECTURE

## TAPE SELECTOR CIRCUIT D'

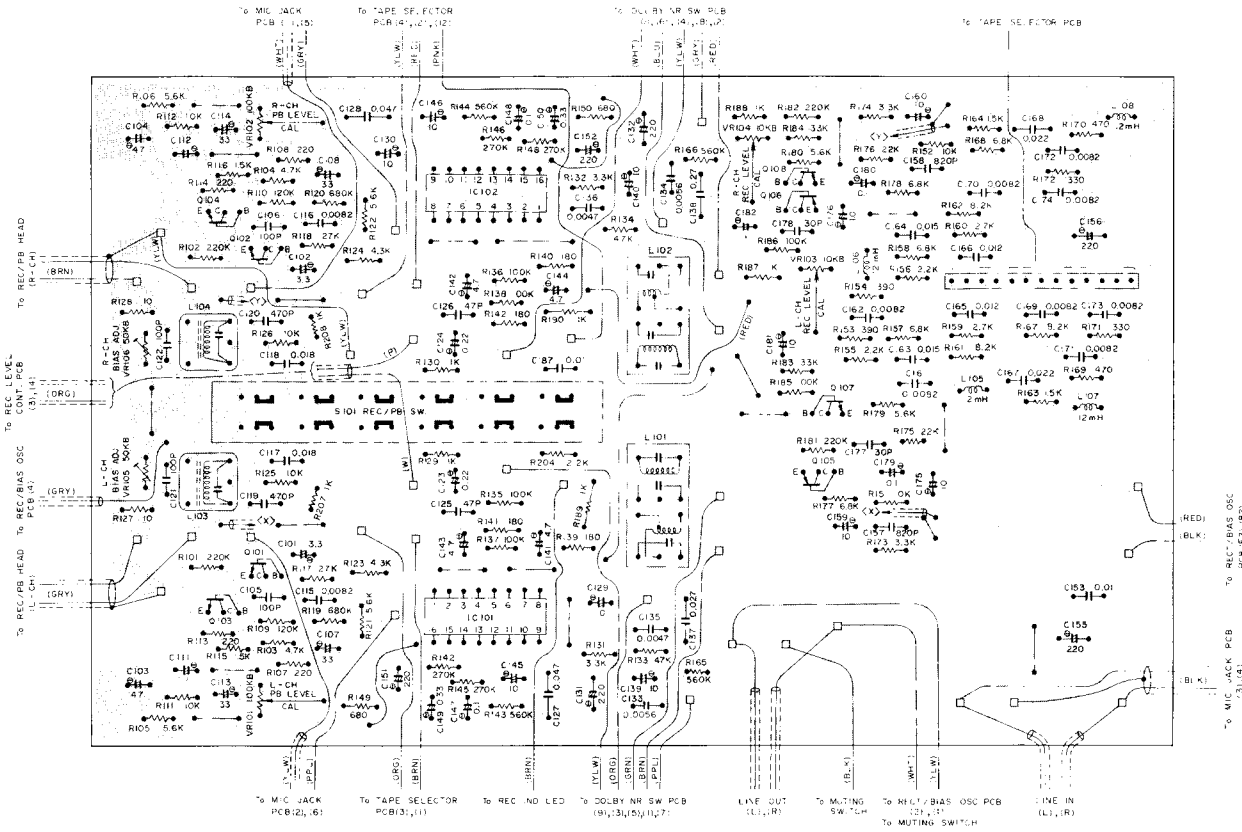

## RECTIFIER AND INDICATOR DRIVER CIRCUIT CIRCUIT DE REDRESSEUR ET D'ATTAQUE DE L'INDICATEUR

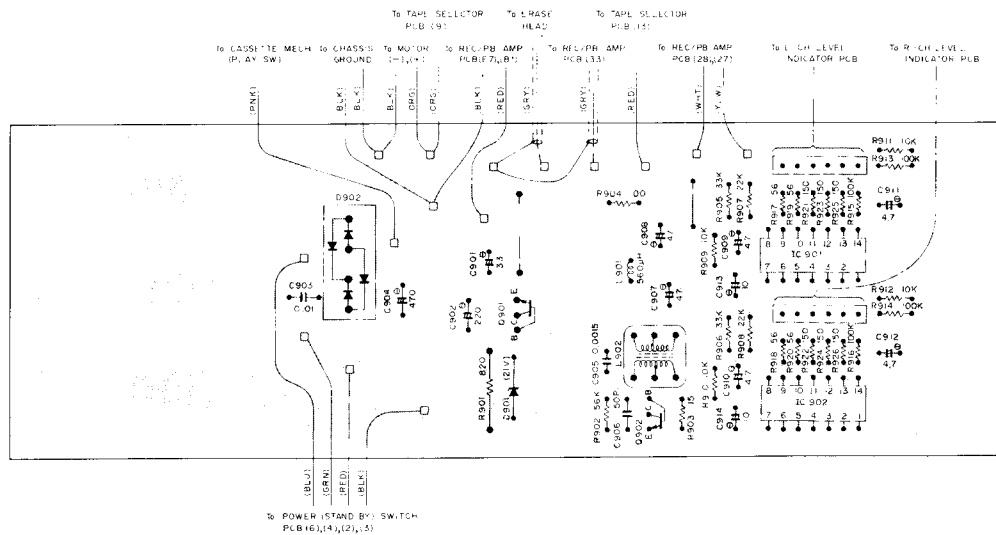

## AUTO SHUT-OFF CIRCUIT CIRCUIT D'ARRET AUTOMATIQUE

## MODIFIED CIRCUIT PATTERN

## LEVEL INDICATOR CIRCUIT CIRCUIT DE L'INDICATEUR DE NIVEAU

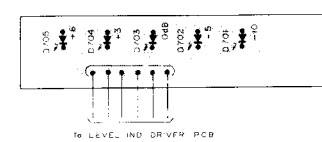
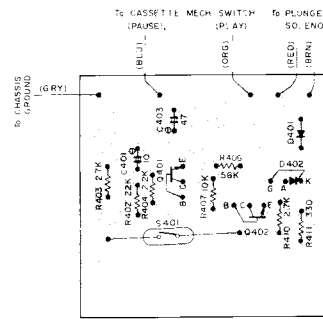
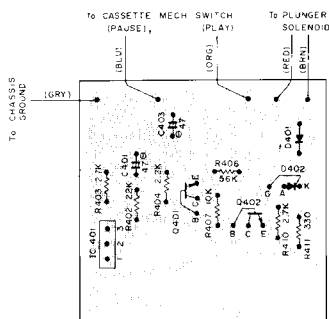

# RMA-80

## TAPE SELECTOR AND DOLBY NR CIRCUIT CIRCUIT DE SELECTEUR DE BAND ET DOLBY NR

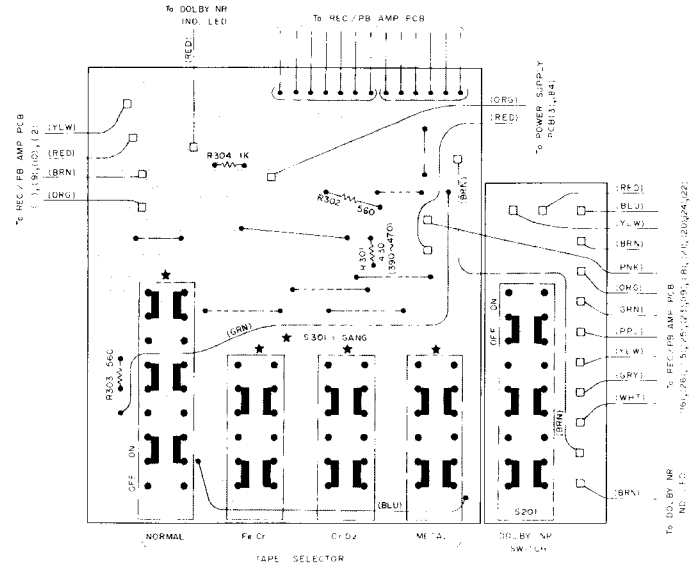

## tone Amplifier and Power Supply Circuit CIRCUIT D'AMPLI DE TONALITE ET D'ALIMENTATION

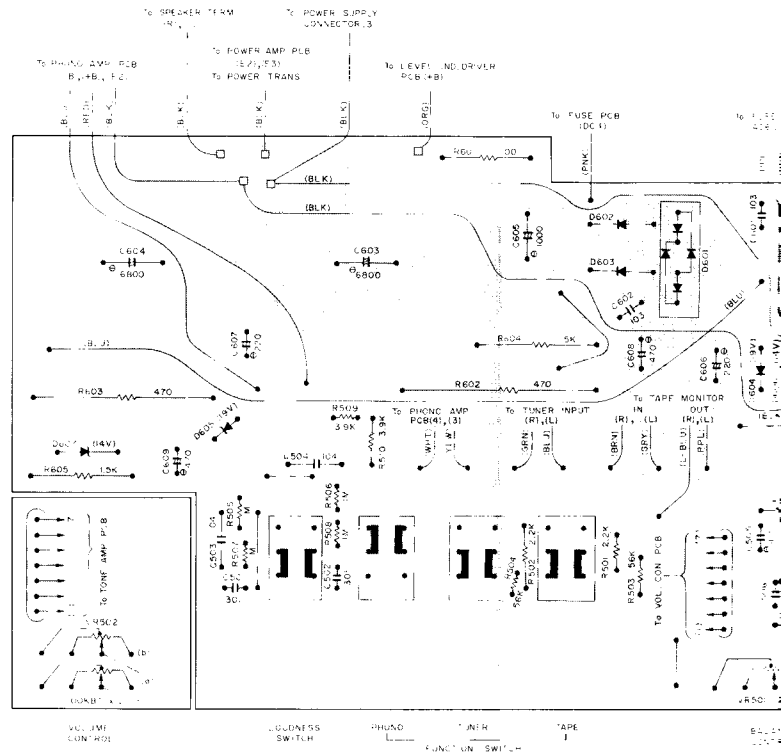

## PHONO AMPLIFIER CIRCUIT CIRCUIT D'AMPLI PHONOGRAPHIQUE

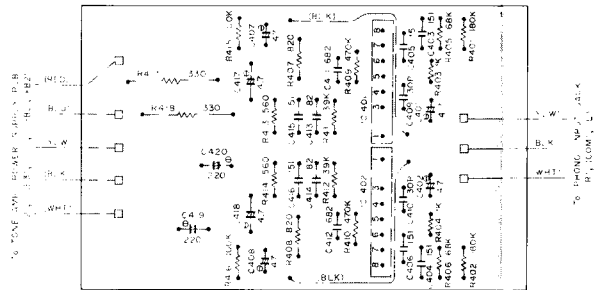

## POWER AMPLIFIER CIRCUIT CIRCUIT D'AMPLI PRINCIPALE

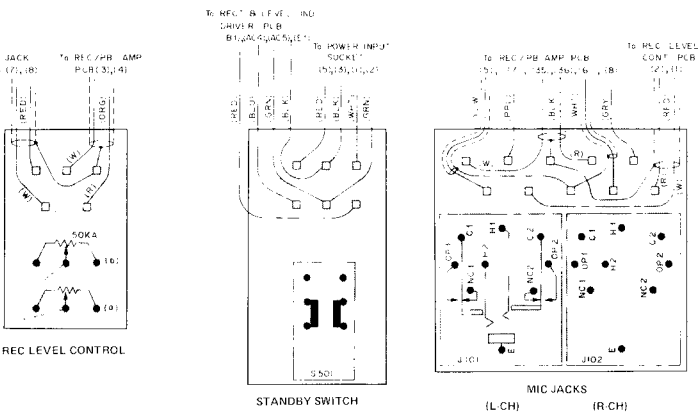
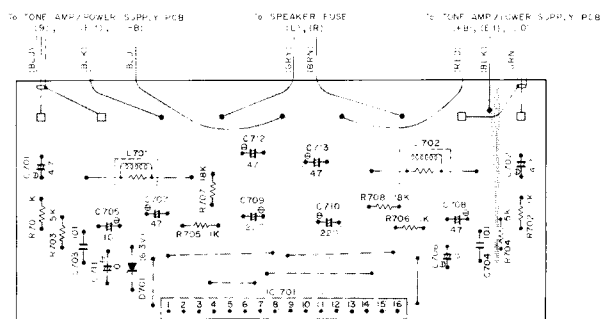

# RMT-80/80L

## TUNER CIRCUIT CIRCUIT TUNER

## CIRCUIT MENTATION

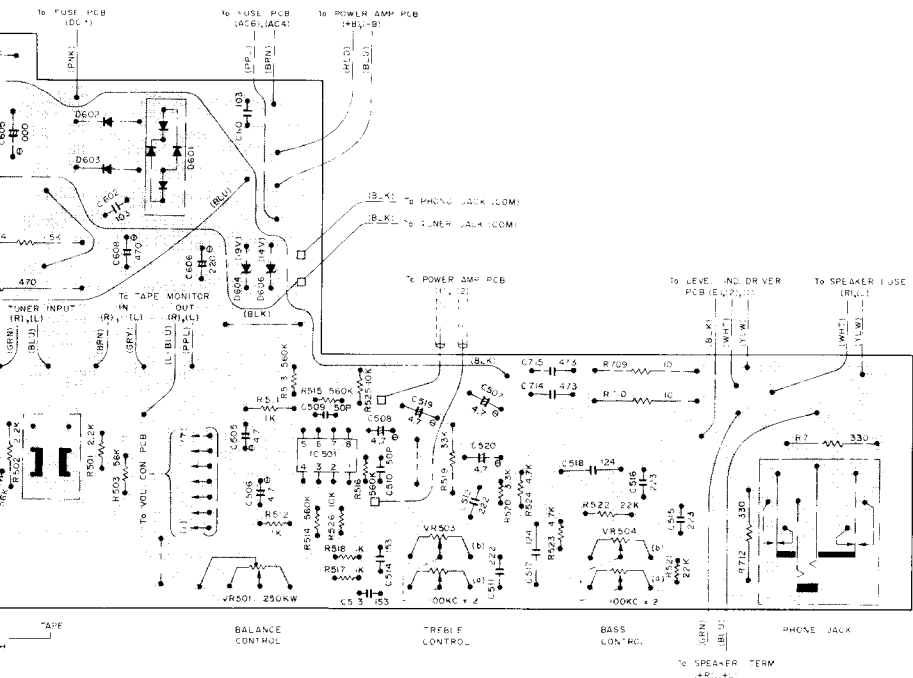

## LEVEL INDICATOR DRIVER CIRCUIT CIRCUIT D'ATTAQUE DE L'INDICATEUR DE NIVEAU

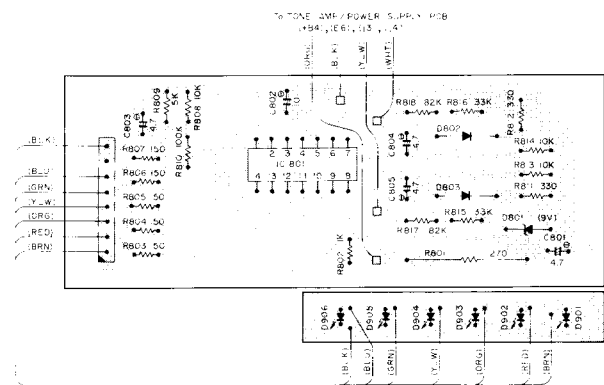

## FUSE CIRCUIT CIRCUIT DE FUSIBLE

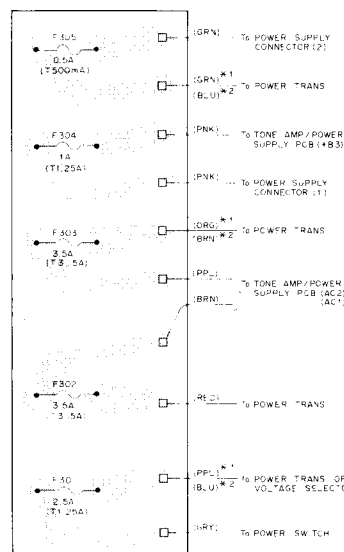

\*1: Indicates lead color for 2L type transformer.  
\*2: Indicates lead color for toroidal type transformer.

**Note:** Values in parentheses are for 220V/240V area (Europe, UK, etc.)

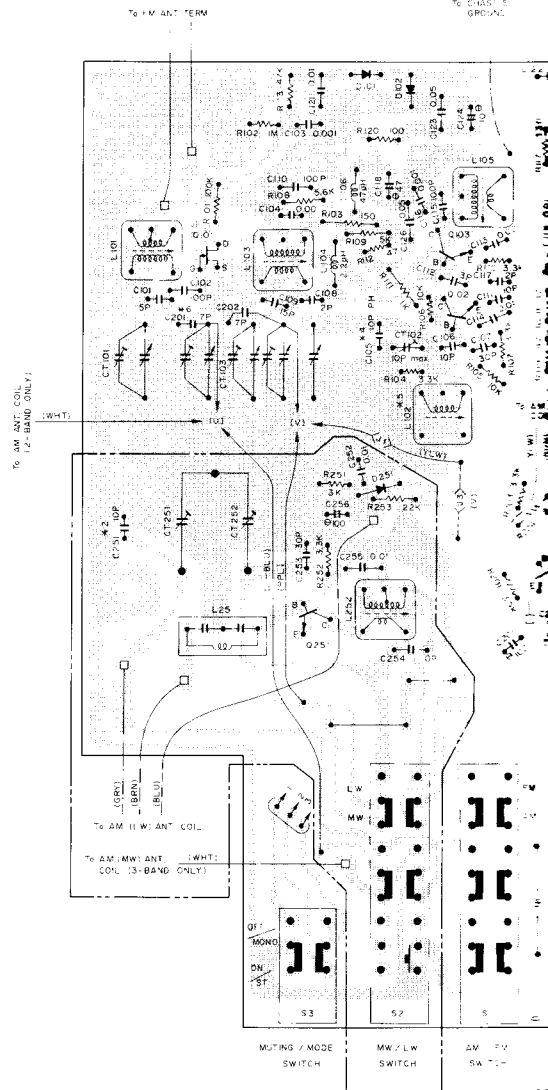

   applicable to RMT-80L only.

- J1 and J2 are for Model RMT-80 only.
- J3, J4, J5, J6, J7, and J8 are for Model RMT-80L
- \*1: C148 and C149 are not used in the case of 50
- \*2: For RMT-80L only.
- Not used when RL-209A is used for AM Antenna when RL-209 is used.
- \*3: For South African Specs, connections are different. Pin 1 → (ORG) Pin 2 → (YLW) Pin 3 → (BLU)
- \*4: For South African Specs, 15pF RH is used for
- \*5: FM OSC coil L102 – STD: RL211 South Africa: RL-214
- \*6: Not used for RMT-80L

# RMT-80/80L

## TUNER CIRCUIT CIRCUIT TUNER

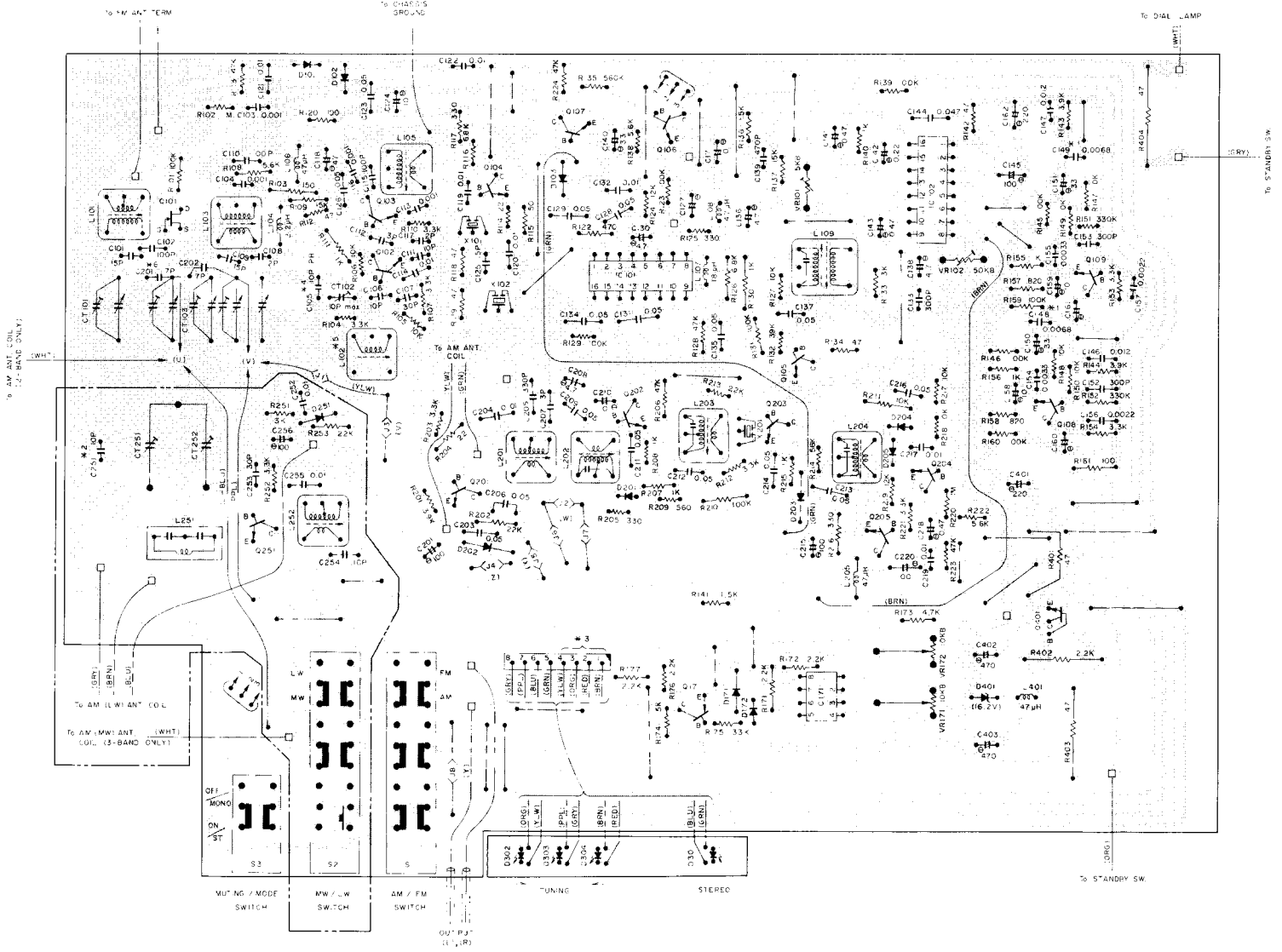

     applicable to RMT-80L only.

J1 and J2 are for Model RMT-80 only.

J3, J4, J5, J6, J7, and J8 are for Model RMT-80L only.

\*1: C148 and C149 are not used in the case of 50μs de-emphasis.

\*2: For RMT-80L only.

Not used when RL-209A is used for AM Ant Coil L001, but used when RL-209 is used.

\*3: For South African Specs, connections are different from the diagrams:

Pin 1 → (ORG) Pin 2 → (YLW) Pin 3 → (BRN) Pin 4 → (RED)

\*4: For South African Specs, 15pF RH is used for C105.

\*5: FM OSC coil L102 —

STD: RL211

South Africa: RL-214

\*6: Not used for RMT-80L