



# Technical Manual

# SURROUND SOUND PROCESSOR RSP-966

### Table of Contents

- Revision .....2
- Parts List .....3~10
- PCB Assembly .....11~18
- Schematic Diagram .....19~26

**THE ROTEL CO., LTD**  
 SHINSEN-BLD. 4F 10-10 SHINSEN-CHO, SHIBUYA-KU,  
 TOKYO 150-0045, JAPAN

*"D" version*

Serial. NO. 9481001 to Beginning
-------------------------------------

# Revision Ver. 2.0

for Revision 1.0 of Technical Manual # NK990301-1 (RSX-965)

This revision is applied for following models.

1. RSX-965 from Serial No. +03001.
2. RSX-965RDS from Serial No. +00501.
3. RTC-965 from Serial No. +00501.
4. RSP-966 from Serial No. +9481001
5. Change from IC CS4926 "B" version to IC CS4926 "D" version

## ◆ Table of Revised Contents

Revised Contents	Model	Remark
Chassis Layout	Same as Revision 1.0	
Specification	Same as Revision 1.0	
Wiring Diagram	Same as Revision 1.0	
Schematic Diagram	Digital PCB Changed	PDF drawing attached
	Others remain same as Revision 1.0	
PC Board Ass'y Parts List	CPU & Digital PCB Parts Changed	Parts change notice attached
Exploded View	Same as Revision 1.0	
Mechanical Parts List	Same as Revision 1.0	

## PARTS LIST (1/8)

SYMBOL	PART NO.	DESCRIPTION
<b>FRONT PCB 4001000100</b>		
	4001000100	PCB Assembly
C600	3439210415	CAP BACK-UP 0.1F/5.5V
C625,626	3519473935	CAP C AXIAL 0.047UF/50V J
C601,C606-C611,C615,C623,624	3519101935	CAP C AXIAL 100PF/50V J
C617-622	3519821935	CAP C AXIAL 820PF/50V J
C633	3579103530	CAP C RADIAL 0.01UF/50V J
C634	3479322871	CAP E SG 0.22UF/50V
C632	3479333971	CAP E SG 3.3UF/50V
C631	3479347971	CAP E SG 4.7uF/50V
CP602	4428629265	CNT FPC PLUG EL AN 00-8370-297
CN601	436209353524	CTG 0935 S03,T03 DL #26 P2.0
D616,D618	2258128002	DIODE 1N4004
D600-60, D606-610, D614,D615, D619-622	2058322101	DIODE 1N4148
FL600	2328000302	FIP SVR08LM02
	6515000110	HOLDER FL, ABS BLACK XR-401
U600	2138322010	IC CPU CXP828P60Q-1
D627	2371140711	LED SLR56VR3FL
	2408000180	REMOCON SENSOR CRV1M352-B
R888	3029101970	RES MF 100 1/8W J
R625	3029104970	RES MF 100K1/8W J
R600,620,622,623,634-642	3029103970	RES MF 10K 1/8W J
R662-678	3029124970	RES MF 120K 1/8W J
R601-602,R607-611, R615, R621, 657, 659-661	3029102970	RES MF 1K 1/8W J
R618	3029271970	RES MF 270 1/8W J
R626,627	3029229970	RES MF 2R2 1/8W J
R616	3029331970	RES MF 330 1/8W J
R658	3029333970	RES MF 33K 1/8W J
R630-633	3029473970	RES MF 47K 1/8W J
R617,619,624,629,646-656	3029472970	RES MF 4K7 1/8W J
XT601	3938124010	RESONATOR CST10.0MTW-TF01
	4658000110	SW TACT SKHVBD010
Q604,Q605	2238006104	TR NPN KRC107M
Q602	2208606104	TR NPN KTC3198Y-AT
	3218000210	VR ENCODER EC16B242040A
	3218000110	VR ENCODER EC16B243040F
<b>DB-25 PCB 4001000170</b>		
	4001000170	PCB Assembly
C870	3519103915	CAP C AXIAL 0.01UF/16V J
C863-866,868	3519101935	CAP C AXIAL 100PF/50V J
C862	3479310971	CAP E SG 1uF/50V
C835,837,838,840	3479347971	CAP E SG 4.7uF/50V
C841,842,860,861	3479347061	CAP E SG 47UF/35V
CB801	4428813464	CNT HOUSING EL 20-8283-013
CB802	4428815464	CNT HOUSING EL 20-8283-015
CP502	4428511416	CNT PLUG ST GIL-S-11P-S2T2-EF
D800	2058322101	DIODE 1N4148
U800	2168017140	IC LC78213 ANALOG SWICH
U801	2168220135	IC NJM5532D DUAL OPAMP
CP821	4438600110	JACK DB25 FEMALE
CP820	4438600120	JACK DB25 MALE
R830,834,835,839,862	3029104970	RES MF 100K1/8W J
R872-4,876	3029103970	RES MF 10K 1/8W J
R,863-865,875,878-883,887	3029102970	RES MF 1K 1/8W J
R840,841,860,861	3029221970	RES MF 220 1/8W J
R832,837	3029472970	RES MF 4K7 1/8W J
R866-868,R870	3029512970	RES MF 5K1 1/8W J
<b>POWER SUPPLY PCB 4001000160</b>		
	4001000160	PCB Assembly
C829,834	3579104530	CAP C RADIAL 0.1UF/50V J

## PARTS LIST (2/8)

SYMBOL	PART NO.	DESCRIPTION
C821	3419510241	CAP E SG 1000UF/25V
C825	3479310071	CAP E SG 10uF/50V
C822,823	3479310971	CAP E SG 1uF/50V
C824	3479347071	CAP E SG 47UF/50V
C826-828	3679473120	CAP MYLAR 0.047UF/100V J
CP808	4428509416	CNT PLUG ST GIL-S-9P-S2T2-EF
CP806	4428504526	CNT PLUG ST MO 5267-04
CN804	436204103524	CTG 0410 S04,T04 DL #26 P2.0
D820-823	2258128002	DIODE 1N4004
D825-827	2058322101	DIODE 1N4148
D829	2258599300	DIODE ZENER T-72 UZ30V
D830	2258599439	DIODE ZENER T-72 UZ4V3
D828	2258599919	DIODE ZENER T-72 UZ9V1
CP805	4235007410	GND PLATE MET37-0002
U802	2168602105	IC KIA7805P REG.
R822	3029103970	RES MF 10K 1/8W J
R821	3029102970	RES MF 1K 1/8W J
R825	3029332970	RES MF 3K3 1/8W J
R826	3029470970	RES MF 47 1/8W J
R820	3029470470	RES MF 47 1W J
R828,829	3029472970	RES MF 4K7 1/8W J
R823	3029560970	RES MF 56 1/8W J
Q822	2208606104	TR NPN KTC3198Y-AT
Q821	2208206105	TR PNP KTA1266Y
<b>POWER SW PCB 4001000110</b>		
	4001000110	PCB Assembly
C833	3549472109	CAP C 0.0047UF/400V AC
CN801	436502302147	CTJ 0230 201,210 DL #22 P7.92
	4628000110	SW PWR SDDL B15700
<b>STANDBY PCB 4001000150</b>		
	4001000150	PCB Assembly
C831	3549472109	CAP C 0.0047UF/400V AC
CP804	4428504416	CNT PLUG ST GIL-S-4P-S2T2-EF
CP801/CP802	4428502746	CNT PLUG ST JE202B-1 T-2(3-2) P7.92
CP800	4428502726	CNT PLUG ST MO 35328-0210 P7.92
D824	2258128002	DIODE 1N4004
T801	2648701170	FILTER TR25
F802	5508301235	FUSE 50TL 250MA/250V
F801	5508301735	FUSE 50TL 630mA/250V
	4255000410	FUSE CLIP CNT47-0007
GND800	4235007410	GND PLATE MET37-0002
RLY800	5528001640	RELAY G5PA-1 DC12V
R800	3029335380	RES MF 3M3 1/2W J ERC
	6715000510	SPONGE PCB BTM (90X40X12T)
T800	2828000047	TRANSFORMER STANDBY (230V/50Hz)
<b>DIGITAL PCB 4002001400</b>		
	4002001400	PCB Assembly
L901,L905,L907	2648702141	BEAD COIL BK2125 HS470
C903-904,C907-908,C912,C915, C929,C959	3536153122	CAP C 2012 CHIP 0.015UF/50V J
C901,C905-906,C909-911,C921, C923-925,C930, C935, C937,C941- 946, C949, C955-957,C960- 961,C963, C965-970,C972,C974, CCT904,CFL904,CFR904,CSL904,C	3536104122	CAP C 2012 CHIP 0.1UF/50V J
SR904,CSW904	3536122122	CAP C 2012 CHIP 1200PF/50V J
C928	3536152122	CAP C 2012 CHIP 1500PF/50V J
C914,C917,CCT902-903,CFL902- 903, CFR902-903,CSL902- 903,CSR902-903, CSW903	3536222122	CAP C 2012 CHIP 2200PF/50V J

## PARTS LIST (3/8)

SYMBOL	PART NO.	DESCRIPTION
C933-934	3536270122	CAP C 2012 CHIP 27PF/50V J
C975	3536471122	CAP C 2012 CHIP 470PF/50V J
C913,C916	3536470122	CAP C 2012 CHIP 47PF/50V J
C902,C971,CCT901,CCT905,CFL901,CFL905,CFR901,CFR905,CL901-903, CR901-903, CSL901,CSL905,CSR901.	3479310071	CAP E SG 10uF/50V
C932	3479310971	CAP E SG 1uF/50V
C958	3479322971	CAP E SG 2.2UF/50V
C920,C922,C931,C936,C938-940,C947-948,C962,C973	3479347041	CAP E SG 47uF/25V
CB901	4428807464	CNT HOUSING EL 20-8283-007
CB902	4428811464	CNT HOUSING EL 20-8283-011
CB903	4428815464	CNT HOUSING EL 20-8283-015
	436601600140	CTW 01600 #22 GRN JUMPER WIRE
D901-902	2257104100	DIODE KDS226RTK
U912	2108019128	IC 74HCT125
U903-904	2138001135	IC 74HCU04
U913-914	2109001150	IC 74VHC 574M
U915	2138408003	IC A278308-70 PROM
U917	2168639100	IC BA033FP-E2 REG.
U916	2138322101	IC CPU CXP82316-527Q
U907	2138212000	IC CS4226-KQ CODEC
U911	2138112002	IC CS492604-CL
U905-906,U908-910	2168220142	IC NJM5532M DUAL OPAMP
RCA901 - ALL AREA	4438101020	JACK RCA 2P(BK)
U901,902	2408218001	OPTO JACK RX-8A
R905,R912,R920-921,R930-936,R950-952	3099101170	RES CHIP 2012 100 J
R906,R913,RCT902,RCT908,RFL902,RFL908,RFR902,RFR908,RL903,RL908,RL911,RR903,RR908,RR911,RSL902,RSL908,RSR902,RSR908,RSW902,RSW908	3099104170	RES CHIP 2012 100K J
R902-903,R907,R910,R914,R917,R922-923,R925,R927,R940-942,R944, R949,R954-961,R965-972, R977-984, R987,RL905-R909,R916,RCT907,RFL907,RFR907,RL909-910,RR909-910,RSL907,RSR907,RSW907	3099103170	RES CHIP 2012 10K J
RCT903-905,RFL903-905,RFR903-905,RSL903-905,RSR903-905,RSW903-905	3099122170	RES CHIP 2012 1K2 J
RL904,RR904	3099182170	RES CHIP 2012 1K8 J
RCT906,RFL906,RFR906,RSL906,RSR906,RSW906	3099203170	RES CHIP 2012 20K J
R901,R928,R962,R973,R974,R975,R976,R985,R986,R962, R973-976,R985-986	3099222170	RES CHIP 2012 2K2 J
R926	3099229170	RES CHIP 2012 2R2 J
R908,R915,R943,R945-946	3099333170	RES CHIP 2012 33K J
R904,R911	3099472170	RES CHIP 2012 4K7 J
R948	3099750170	RES CHIP 2012 75 J
XT902	3099821170	RES CHIP 2012 820 J
Q901-909	3938124010	RESONATOR CST10.0MTW-TF01
XT901	2207606010	TR KRC107S
	3908101130	X-TAL 12.288MHZ
<b>INPUT AUDIO PCB 4002000400</b>		
	4002000400	PCB Assembly
C325,CL,R301,302,313-322,331,332,335,336,RC354,355	3519101935	CAP C AXIAL 100PF/50V J
CL307,CR307	3479322871	CAP E SG 0.22UF/50V

## PARTS LIST (4/8)

SYMBOL	PART NO.	DESCRIPTION
C323	3479310971	CAP E SG 1uF/50V
CL309,CR309	3479333061	CAP E SG 33UF/35V
CL303,330,333,334,337,CR303,330,333,334,337	3479347971	CAP E SG 4.7uF/50V
C309,310,324,326-329,335	3479347041	CAP E SG 47uF/25V
CL/CR305,CL/CR308	3679182120	CAP MYLAR 0.0018UF/100V J
CL,R304	3679222120	CAP MYLAR 0.0022UF/100V J
CL,R306	3679562120	CAP MYLAR 0.0056UF/100V J
CP301	4428808464	CNT HOUSING EL 20-8283-008
CP302	4428811464	CNT HOUSING EL 20-8283-011
D301	2058322101	DIODE 1N4148
D351	2058322101	DIODE 1N4148
U302	2168017132	IC LC78211 ANALOG SWITCH
U301,303,304	2168220135	IC NJM5532D DUAL OPAMP
	4438100120	JACK RCA 2P(W,R)
	4438100220	JACK RCA 4P(WW,RR)
	4438100320	JACK RCA 6P(WWW,RRR)
R318,RL,R308,327,329,332,334,RL,R328,333	3029104970	RES MF 100K1/8W J
R319-321,RL,R301,311-315,326,330,331,335	3029103970	RES MF 10K 1/8W J
R309,310,316,317,322-325	3029102970	RES MF 1K 1/8W J
RL,R305	3029221970	RES MF 220 1/8W J
RL,R307	3029433970	RES MF 43K 1/8W J
RL,R304	3029561970	RES MF 560 1/8W J
RL,R306	3029564970	RES MF 560K 1/8W J
RL,R302,303	3029821970	RES MF 820 1/8W J
	3029913970	RES MF 91K 1/8W J
<b>INPUT VIDEO PCB 4002000410</b>		
	4002000410	PCB Assembly
C368,CL,R350-361	3519101935	CAP C AXIAL 100PF/50V J
C366	3479310971	CAP E SG 1uF/50V
CL362,CR362	3479347971	CAP E SG 4.7uF/50V
C363-365,367	3479347041	CAP E SG 47uF/25V
CP351	4428809464	CNT HOUSING EL 20-8283-009
U351	2168017132	IC LC78211 ANALOG SWITCH
U352	2138001115	IC MULTIFLEX BU4053BC
	4438100320	JACK RCA 6P(WWW,RRR)
R360,RL,R366	3029104970	RES MF 100K1/8W J
R362-364,RL,R350-355	3029102970	RES MF 1K 1/8W J
R361,365,	3029221970	RES MF 220 1/8W J
R356-359	3029332970	RES MF 3K3 1/8W J
<b>MAIN PCB 4002000100</b>		
	4002000100	PCB Assembly
C105	3409310331	CAP E SG 10000UF/16V
C108-111,125	3479310971	CAP E SG 1uF/50V
C106,124	3409322231	CAP E SG 2200UF/16V
	3479347131	CAP E SG 470uF/16V
C118-123,C126,127	3679473120	CAP MYLAR 0.047UF/100V J
FPC101	4428629266	CNT FPC PLUG EL ST 00-8370-291
W503	4428805466	CNT PLUG EL 00-8283-0512
W801	4428807466	CNT PLUG EL 00-8283-0712
W119	4428808466	CNT PLUG EL 00-8283-0812
W120	4428809466	CNT PLUG EL 00-8283-0912
W502	4428810466	CNT PLUG EL 00-8283-1012
W118,802	4428811466	CNT PLUG EL 00-8283-1112
W112,122	4428813466	CNT PLUG EL 00-8283-1312
W113,121,501,803	4428815466	CNT PLUG EL 00-8283-1512
	4428503416	CNT PLUG ST GIL-S-3P-S2T2-EF
CP101,107	4428503526	CNT PLUG ST MO 5267-03
	436203123524	CTG 0312 S03,T03 DL #26 P2.0
D102-109,D113,114	2258128002	DIODE 1N4004
	2058322101	DIODE 1N4148

## PARTS LIST (5/8)

SYMBOL	PART NO.	DESCRIPTION
F101-102	5508302335	FUSE 50TL 1.6A/250V
F103-104	5508302435	FUSE 50TL 2A/250V
CP805,101	4255000410	FUSE CLIP CNT47-0007
	4235007410	GND PLATE MET37-0002
	7505000110	H/SINK REG TR 15X30
	7505000130	H/SINK REG TR 15X60
	7505000230	H/SINK REG TR 24X60
U105,107	2168602105	IC KIA7805P REG.
U102	2168602109	IC KIA7815P REG.
U104	2168602112	IC KIA7905PI REG.
U103	2168602114	IC KIA7915P REG.
U101	4438300110	JACK RCA YKB21-5103A
	2408000136	OPTO. COUPLER LTV-817
R106	3029221970	RES MF 220 1/8W J
RTC101	3029332970	RES MF 3K3 1/8W J
R105	3029472970	RES MF 4K7 1/8W J
Q104	3029561970	RES MF 560 1/8W J
	2208606104	TR NPN KTC3198Y-AT
<b>PROCESSOR PCB 4002000500</b>		
	4002000500	PCB Assembly
CSW506,510,515	3536563122	CAP C 2012 CHIP 0.056UF/50V J
CML502,CMR502,CSW502	3536104122	CAP C 2012 CHIP 0.1UF/50V J
CSW516	3536102122	CAP C 2012 CHIP 1000PF/50V J
C521,CC503,CC514,CF501,CF508,	3536101122	CAP C 2012 CHIP 100PF/50V J
CFL502-3,CFL507-8, 511,CFR502-3,507-8,511,CSL503,507,CSR503,507,CS		
CSW507	3536222122	CAP C 2012 CHIP 2200PF/50V J
CFL517,CFR517	3536270122	CAP C 2012 CHIP 27PF/50V J
CSW511	3536822122	CAP C 2012 CHIP 8200PF/50V J
CC502,513,CSL502,506,CSR502,50	3536821122	CAP C 2012 CHIP 820PF/50V J
CFL501,524,CFR501,524,CML503,C	3479310071	CAP E SG 10uF/50V
MR503		
CFL518,CFR518	3479310971	CAP E SG 1uF/50V
CC501,504,512,515,516,CFL,CFR5	3479347971	CAP E SG 4.7uF/50V
04-6,509-10, 519, 525,		
CML,CMR501,CSL,CSR501, 504-		
5,508-9, CSW501,504-5, 508-9,512-		
14,517-8		
C501-520,CC505-506,CF504-507,	3479347041	CAP E SG 47uF/25V
CS502-503		
CFL522,CFR522	3679272120	CAP MYLAR 0.0027UF/100V J
CFL521,CFR521	3679123120	CAP MYLAR 0.012UF/100V J
CFL523CFR523	3679223120	CAP MYLAR 0.022UF/100V J
CFL520,CFR520	3679683120	CAP MYLAR 0.068UF/100V J
CB503	4428805464	CNT HOUSING EL 20-8283-005
CB502	4428810464	CNT HOUSING EL 20-8283-010
CB501	4428815464	CNT HOUSING EL 20-8283-015
CN501	436211083524	CTG 1108 S11,T10 DL #26 P2.0
QC501,QF502,QS501,QSW501	2257103110	DIODE KDS184RTK
ZD501-2	2258599919	DIODE ZENER T-72 UZ9V1
U501,503-4,506,508-11,513	2168220142	IC NJM5532M DUAL OPAMP
U514	2168020108	IC NJU7311AM ANALOG SWICH
U505	2138007130	IC TC9184P ELECT TONE
U502,507,512	2138007120	IC TC9459F ELECT VOL
	4438100920	JACK RCA 2P (B,B WOOFER)
	4438100220	JACK RCA 4P(WW,RR)
JF549,JF536	3099000170	RES CHIP 2012 0R J

## PARTS LIST (6/8)

SYMBOL	PART NO.	DESCRIPTION
RC502,505,512,515,519,RFL,RFR503,506,508,510,513,515,524,526,RML,RMR502-3,RSL,RSR502,505,508,511,513,RSW502,505,508,511,413,516,520,523,527RC,RSL,RSR,RSW503/RSL,RSR509,RC513	3099104170	RES CHIP 2012 100K J
RSW521	3099183170	RES CHIP 2012 18K J
R521-3,550,RC501,508,RC520,RF508,RFL501-2,509,514,525,RFR501-2,509,514,525,RML501,RMR50,RSL501,506-7,RSR501,506-7,RSW501,507,517,519RFL523,RFR523	3099103170	RES CHIP 2012 10K J
RC514,RSL510,RSR510	3099122170	RES CHIP 2012 1K2 J
RFL521,RFR521	3099182170	RES CHIP 2012 1K8 J
RFL518,RFR518	3099273170	RES CHIP 2012 27K J
RF501,RSW510	3099393170	RES CHIP 2012 39K J
RFL516,RFR516	3099332170	RES CHIP 2012 3K3 J
RC,RSL,RSR504,RFL504-5,R520,RSW514	3099474170	RES CHIP 2012 470K J
RFL519,RFR519	3099472170	RES CHIP 2012 4K7 J
RFL522,RFR522	3099564170	RES CHIP 2012 560K J
RSW522	3099562170	RES CHIP 2012 5K6 J
RFL517,RFR517	3099821170	RES CHIP 2012 820 J
RFL511,RFR511,RML504,RMR504	3099823170	RES CHIP 2012 82K J
RSW509,515	3099822170	RES CHIP 2012 8K2 J
RC517,RF509,RS504,RSW526	3099912170	RES CHIP 2012 9K1 J
R549,RC516,RF506-7,RSW506,RSW524,RSR,RSL,RSW512,RS505,RFL507,RFR507	3029103970	RES MF 10K 1/8W J
R501-512,R515-R520,RC509-510,RF502-503,RS502-503	3029102970	RES MF 1K 1/8W J
RC511,RS501	3029221970	RES MF 220 1/8W J
RF504-505	3029332970	RES MF 3K3 1/8W J
QC503,QFL501,QFR501,QSL503,QR503,QSW503	3029561970	RES MF 560 1/8W J
QC502,QF501,QS502,QSW502	2238422100	TR NPN DTC323TSTP
	2238006103	TR PNP KRA107M
<b>C-VIDEO PCB 4002000600</b>		
	4002000600	PCB Assembly
C411,416,420,429,441,444,445	3519103915	CAP C AXIAL 0.01UF/16V J
C401,418,437,	3519104935	CAP C AXIAL 0.1UF/50V J
C421,422,423,427,448	3519101935	CAP C AXIAL 100PF/50V J
C436,442	3528330210	CAP C RADIAL 33PF/50V(CH) J
C438,439	3528560210	CAP C RADIAL 56PF/50V(CH) J
C428	3479347871	CAP E SG 0.47UF/50
C406,C430	3479310131	CAP E SG 100UF/16V
C409,414,	3479310071	CAP E SG 10uF/50V
C432,C443,446	3479310971	CAP E SG 1uF/50V
C407,408	3479347121	CAP E SG 470UF/10V
C405,410,412,415,417,430,440	3479347031	CAP E SG 47UF/16V
CN400	4428815464	CNT HOUSING EL 20-8283-015
U402	2108499133	IC MC14577
U403	2168222113	IC KS5520 OSD
U400,401	2168017141	IC LC7824 ANALOG SWICH
L400	2648610082	INDUCTOR AXIAL LAL02TB 100K
L401	2648610182	INDUCTOR AXIAL LAL02TB 101K
	4438100720	JACK RCA 1P(Y)
	4438100520	JACK RCA 3P(Y)
R408,409,415,416,417,426,428	3029101970	RES MF 100 1/8W J
R436	3029104970	RES MF 100K1/8W J
R405	3029181970	RES MF 180 1/8W J



## PARTS LIST (7/8)

SYMBOL	PART NO.	DESCRIPTION
R439	3029184970	RES MF 180K 1/8W
R412,413,414	3029102970	RES MF 1K 1/8W J
R427	3029122970	RES MF 1K2 1/8W J
R424	3029105970	RES MF 1M 1/8W J
R434	3029204970	RES MF 200K 1/8W J
R435	3029223970	RES MF 22K 1/8W J
R425	3029392970	RES MF 3K9 1/8W J
R419,420,422,423	3029471970	RES MF 470 1/8W J
R410,411	3029473970	RES MF 47K 1/8W J
R421	3029472970	RES MF 4K7 1/8W J
R418	3029512970	RES MF 5K1 1/8W J
R431	3029680970	RES MF 68 1/8W J
R401,402,403,404,406,407,438	3029750970	RES MF 75 1/8W J
Q401	2208222106	TR PNP 2SA933STPR
X400-FOR EUROPE	3938201955	X-TAL 17.734475MHZ
<b>S-VIDEO PCB 4002000610</b>		
	4002000610	PCB Assembly
C456	3519103915	CAP C AXIAL 0.01UF/16V J
C450,451,452,	3519101935	CAP C AXIAL 100PF/50V J
C453,455,458,499,460,461,465	3479310071	CAP E SG 10uF/50V
C457,462	3479322971	CAP E SG 2.2UF/50V
C454,463,466	3479347121	CAP E SG 470UF/10V
C464,467,468,469,470- * * * *	3479347041	CAP E SG 47uF/25V
CN451	4428813464	CNT HOUSING EL 20-8283-013
D450-457	2058322101	DIODE 1N4148
U454,455	2108499133	IC MC14577
U450,451,452,453	2168017141	IC LC7824 ANALOG SWICH
	4438500120	JACK S-VIDEO 1P YKF51-5527
	4438500220	JACK S-VIDEO 3P YKF51-5520
R485	3029101970	RES MF 100 1/8W J
R506,493,495	3029103970	RES MF 10K 1/8W J
R478,501	3029124970	RES MF 120K 1/8W J
R489,471	3029184970	RES MF 180K 1/8W
R464,465,466,482,487,494,496-500	3029102970	RES MF 1K 1/8W J
R476	3029222970	RES MF 2K2 1/8W J
R475	3029333970	RES MF 33K 1/8W J
R469,R470,R473,474,480,481,491,492	3029471970	RES MF 470 1/8W J
R468,472,479,490,	3029473970	RES MF 47K 1/8W J
R507	3029560970	RES MF 56 1/8W J
R483,484	3029561970	RES MF 560 1/8W J
R488	3029563970	RES MF 56K 1/8W J
R477	3029680970	RES MF 68 1/8W J
R450-463	3029750970	RES MF 75 1/8W J
R486	3029751970	RES MF 750 1/8W J
Q456,458,463,465	2238006104	TR NPN KRC107M
Q452,453,454,457,459,460,461,462,464	2208606104	TR NPN KTC3198Y-AT
Q450	2208222106	TR PNP 2SA933STPR
Q451,455	2238006103	TR PNP KRA107M
<b>MISCELLANEOUS</b>		
<b>ASS'Y PACKING</b>		
	9605000212	BOX CARTON(INNER)
	9625000212	BOX CARTON(OUT)
	4328200120	CORD RCA 2P(GOLD)1M
	9722000210	CUSHION POLY
	9715000220	FILM SOFT PE(BAG TYPE)
	9007000510	INSTRUCTION MANUAL
	9057000040	LABEL SERIAL (BOX)
	9705000110	POLY BAG

## PARTS LIST (8/8)

SYMBOL	PART NO.	DESCRIPTION
<b>ASS'Y CASING</b>		
	8545000311	BEZEL RING, ABS BLACK
	6715000110	BUMPON
	8523000110	CAP SIDE(L), ABS BLACK
	8523000120	CAP SIDE(R), ABS BLACK
	8535000110	FILTER FL, ACRYL 1.0T
	8543000211	KNOB MAIN(AL)
	8545000211	KNOB ROTARY(AL)
	9057000050	LABEL SERIAL (SET)
	8602000411	PANEL FRONT(AL)
	6715000430	SPONGE PCB TOP (120X6X9T)
	6715000420	SPONGE PCB TOP (230X15X9T)
	6715000210	SPONGE TOP (260X20X1T)
	6122000210	TOP COVER,VCM0.95T
	8553000212	WINDOW DISPLAY,ACRYL 3.0t
<b>ASS'Y WRING</b>		
	6503000110	BKT PANEL(LEFT),SECC1.0T
	6503000120	BKT PANEL(RIGHT),SECC1.0T
	6503000210	BKT PCB,SECC1.0T
	6102000411	CH BACK(EU)
	6121600210	CH MAIN,SECC1.0T
	4308000210	CORD AC PWR(RDS)
	6133100110	FOOT, ABS BLACK
	9057000010	LABEL CAUTION
	9057000030	LABEL MADE IN KOREA
	6515000210	SPACER PCB, ABS BLACK
	6518000110	STOPPER CORD,DACH-1
	4408200110	TERMINAL GND
	2828000077	TRANSFORMER MAIN (230V/50Hz)
<b>ASS'Y FRONT PANEL</b>		
	8521000110	BODY FRONT, ABS BLACK
	8545000110	BTN PWR, ABS BLACK
	436629201182	CTW 2920 KFC,KFC NL 0.1mm P1.25

# PCB Assembly

CHECK		
1	2	3

FP001  
**MAIN B'D**  
**4002000100**

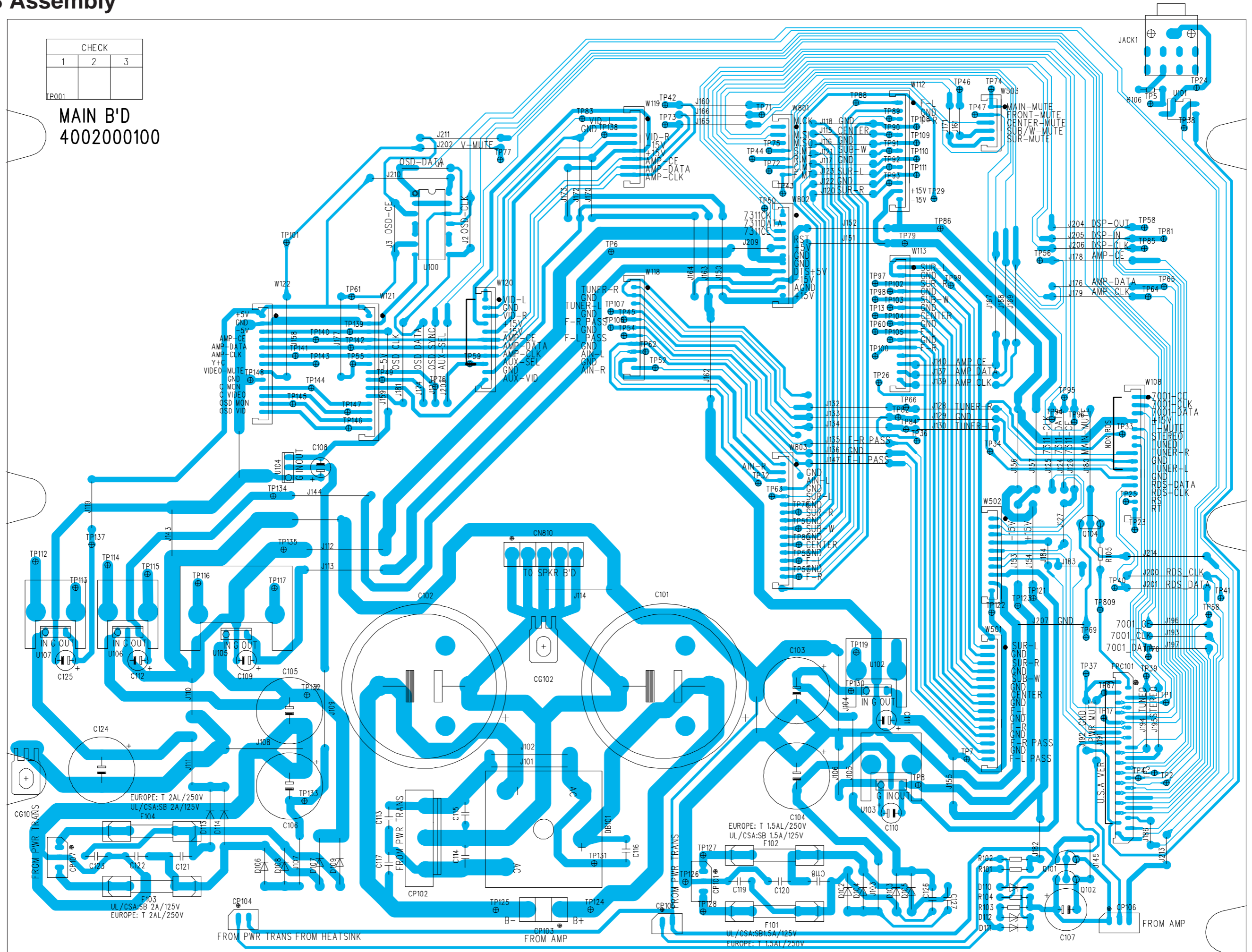

Memo

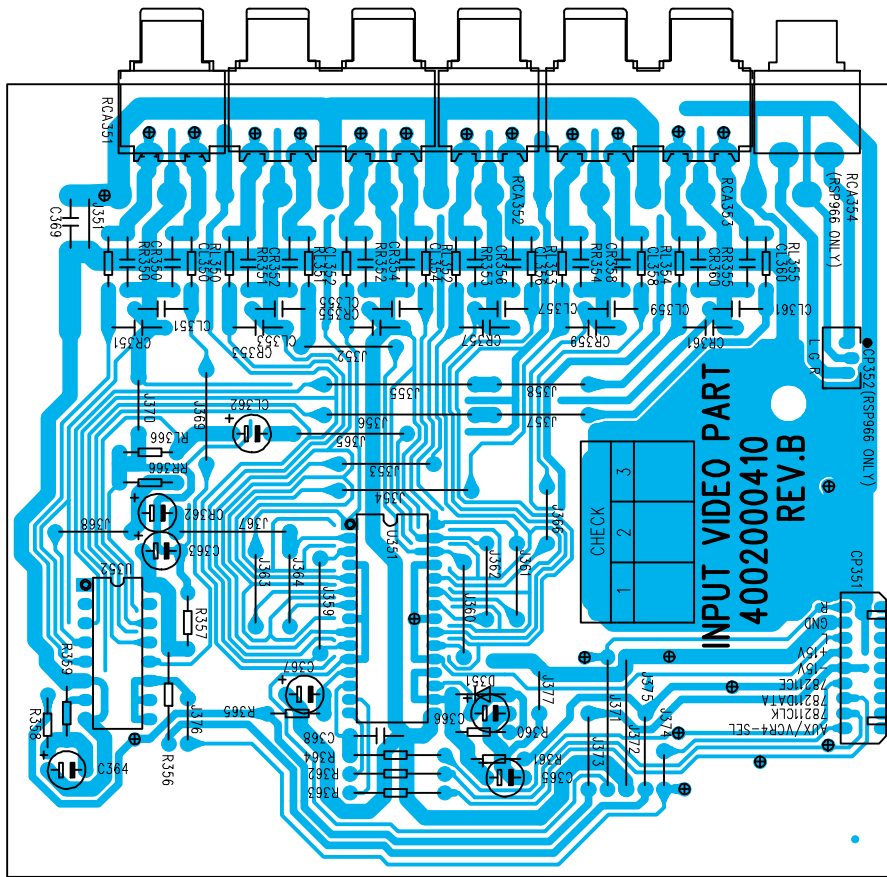

4002000410

INPUT  
VIDEO

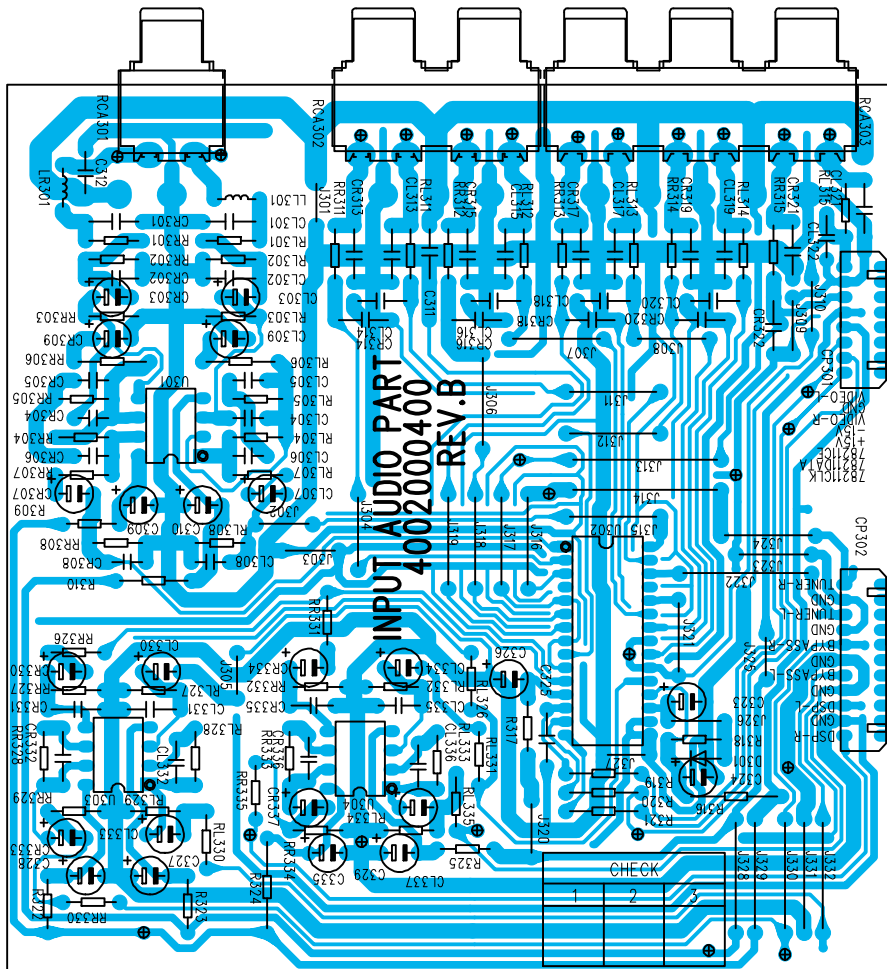

4002000400

INPUT  
AUDIO

# PCB Assembly

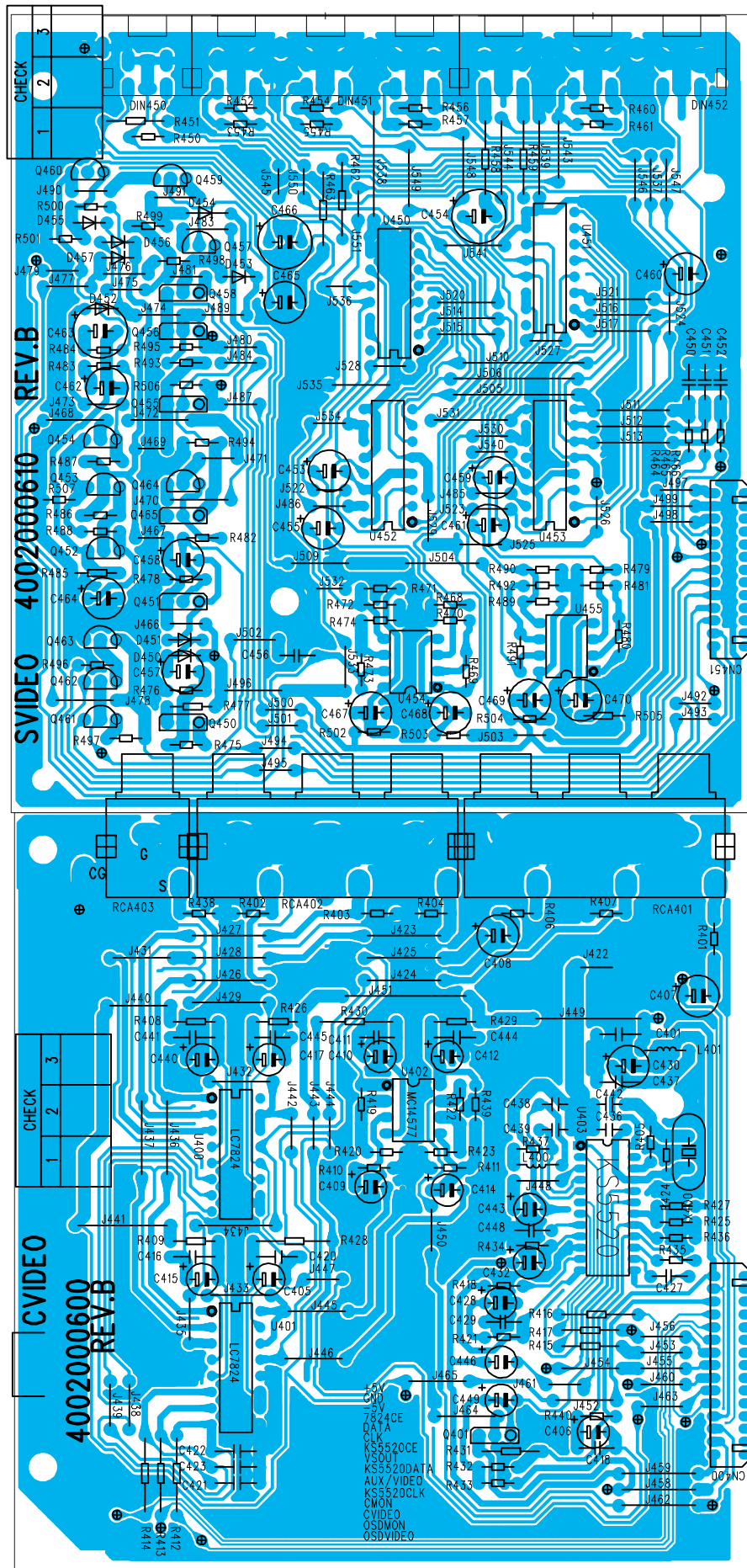

4002000610  
S-VIDEO

4002000600  
COMPOSITE  
VIDEO



# PCB Assembly (DIGITAL BOARD)

TOP SIDE

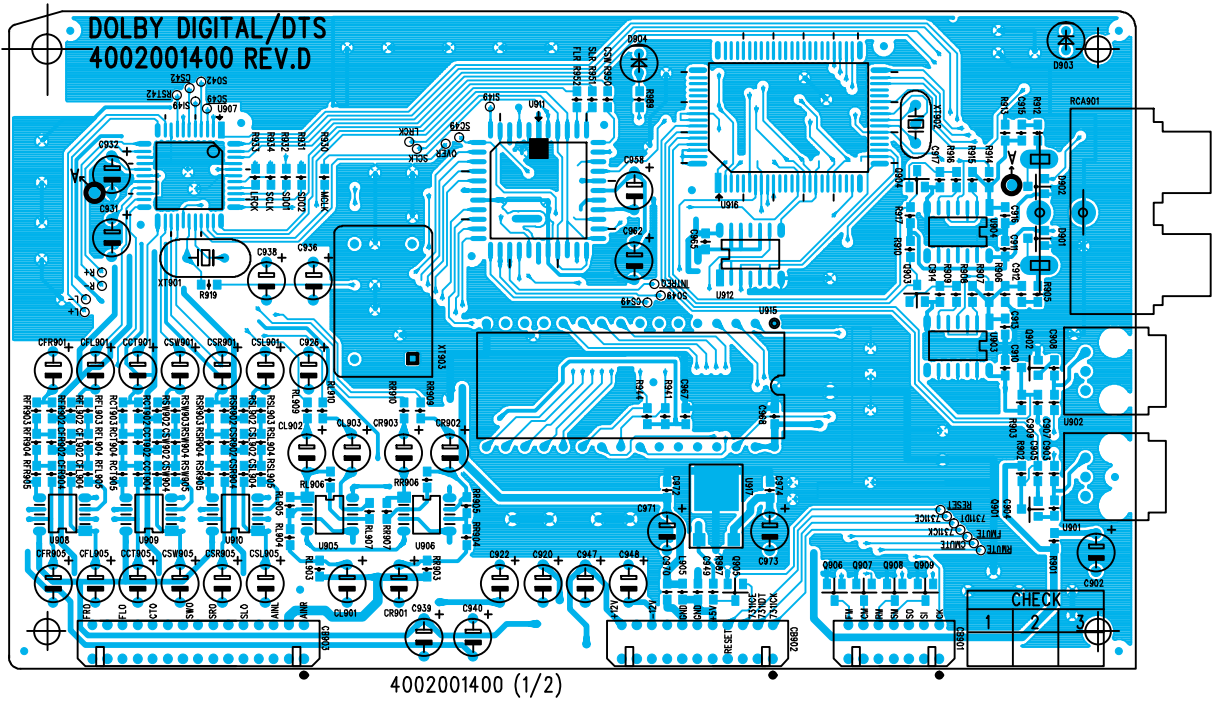

4002001400 (2/2)

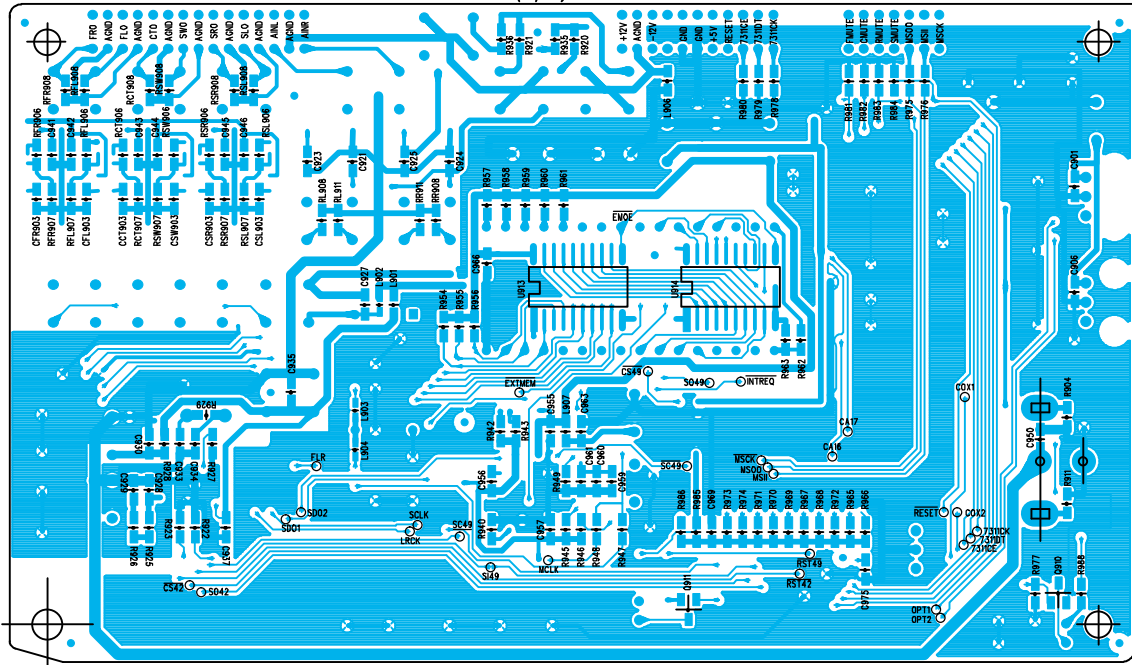

BOTTOM SIDE

# PCB Assembly

4002000500(1/2)

PROCESSOR

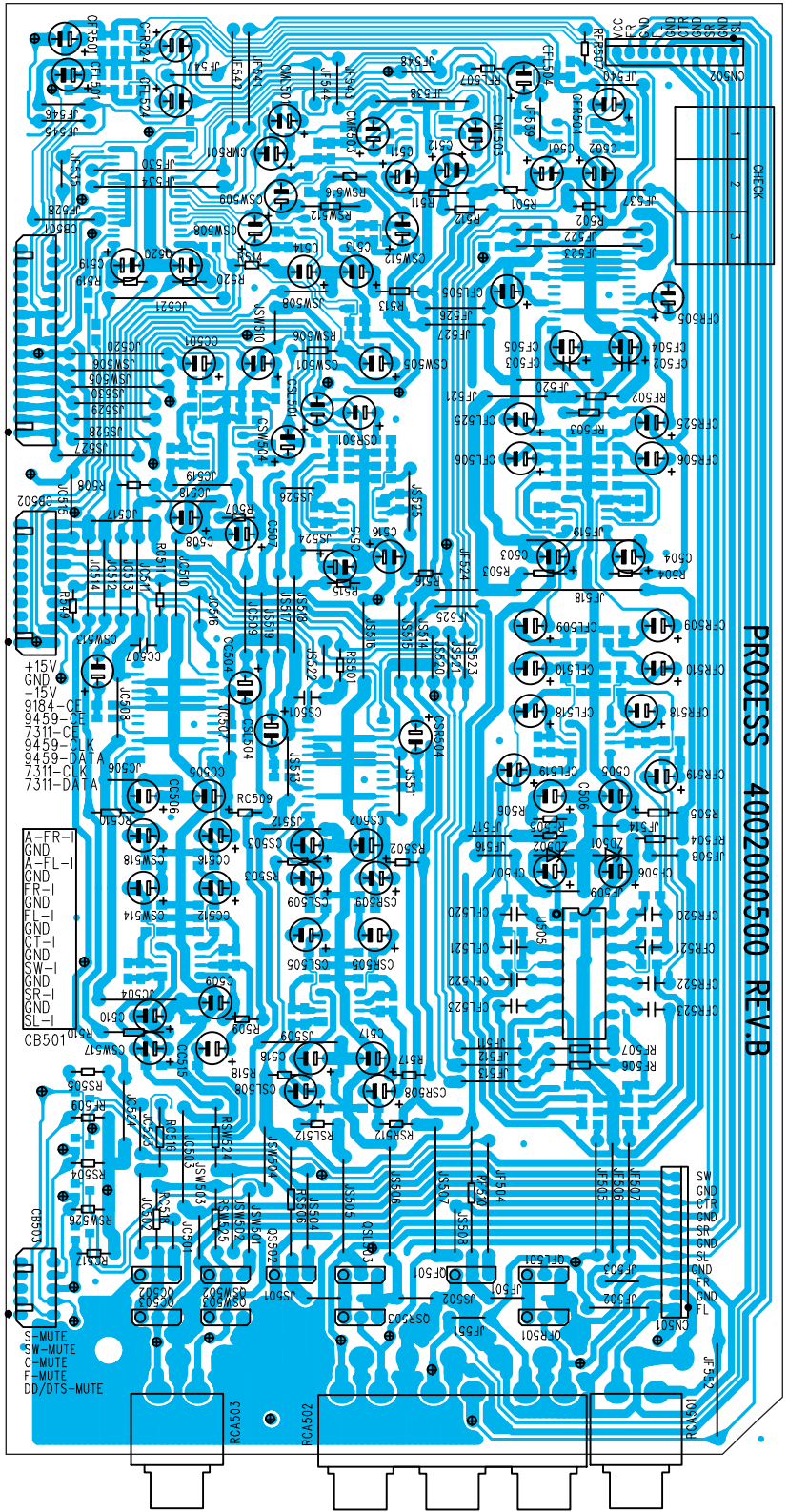

TOP SIDE VIEW



# PCB Assembly

4002000500(2/2)

PROCESSOR

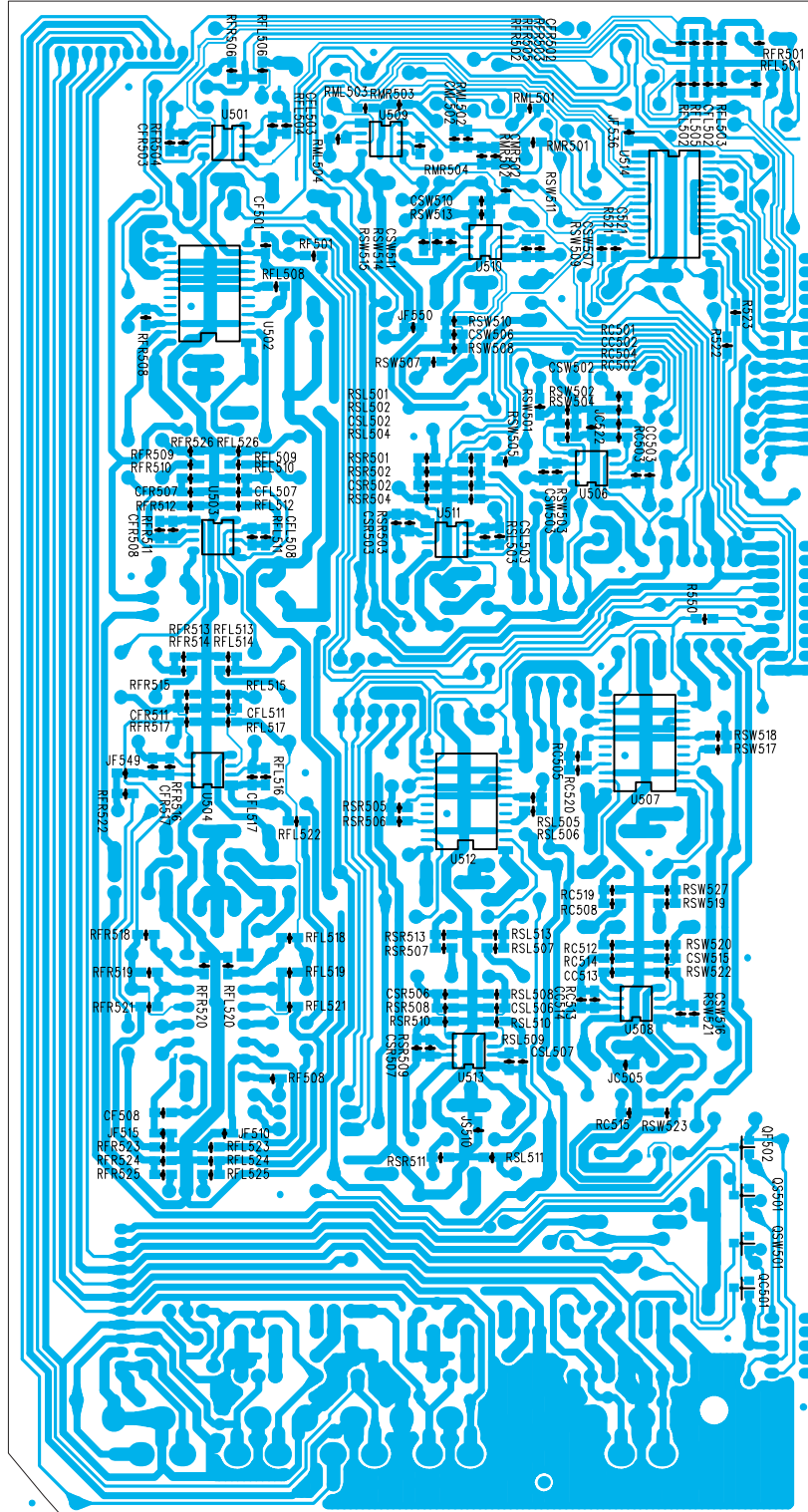

BOTTOM VIEW

Meno

# Block Diagram

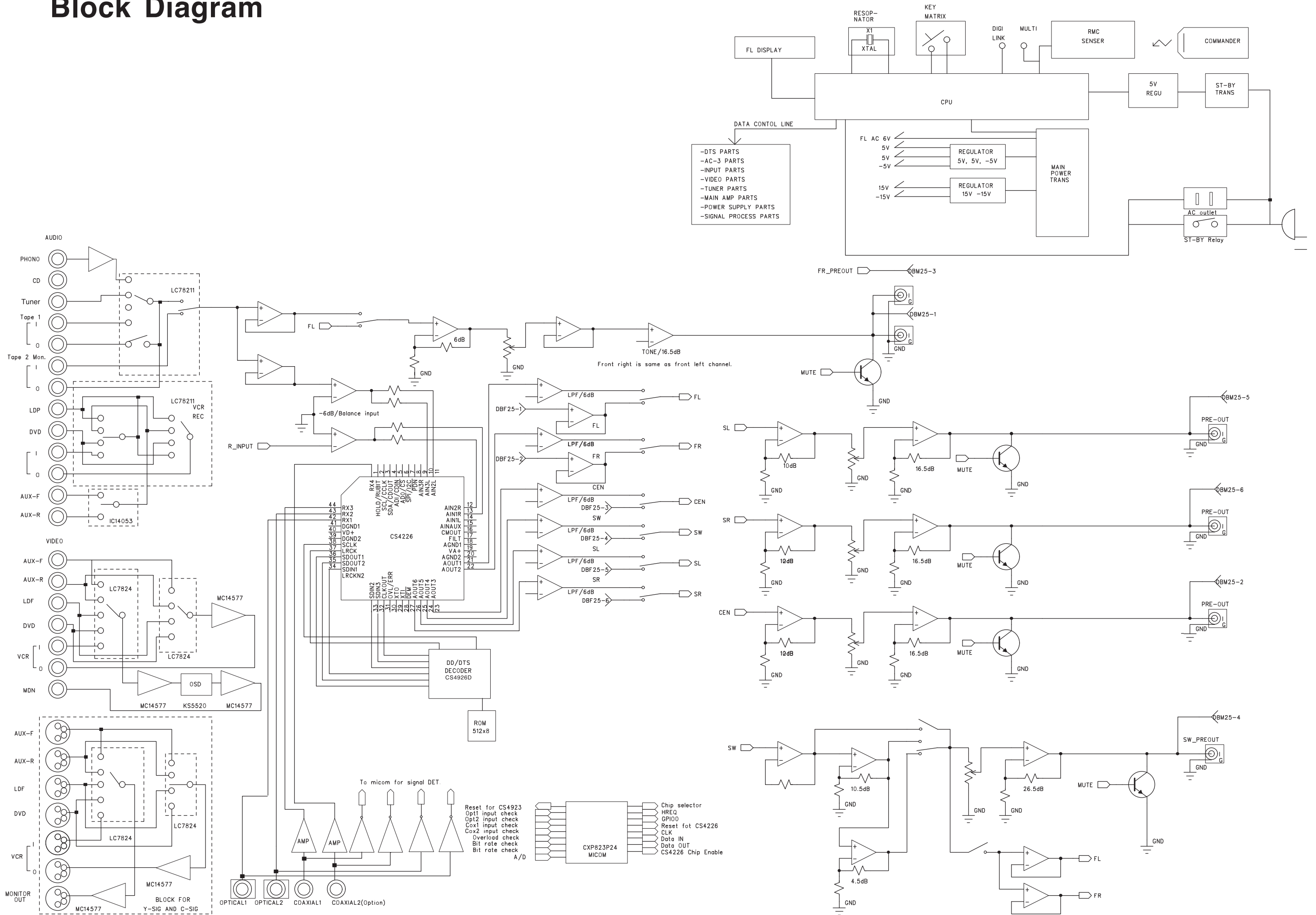

# Schematic Diagram

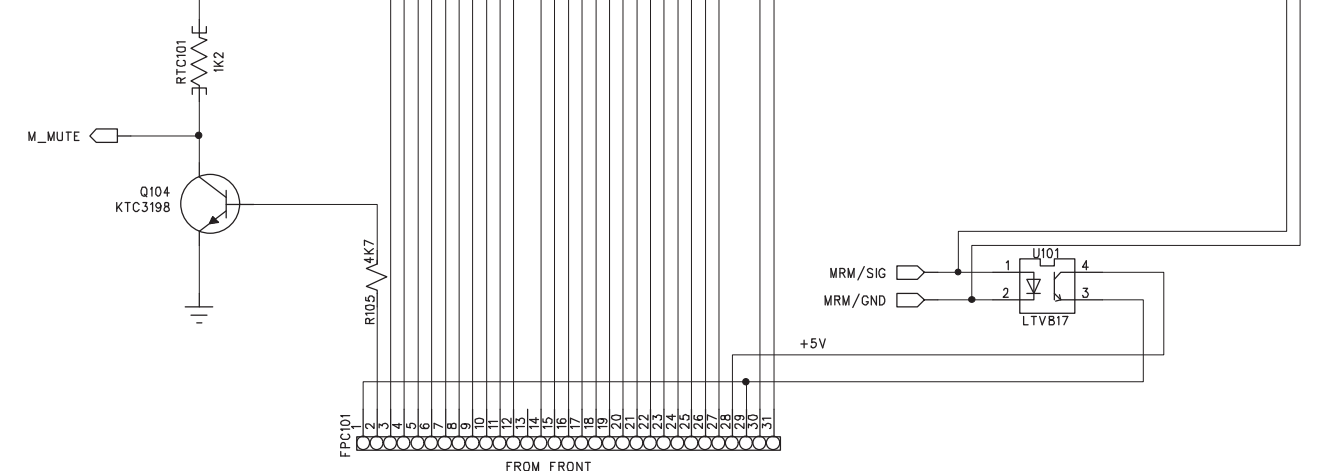
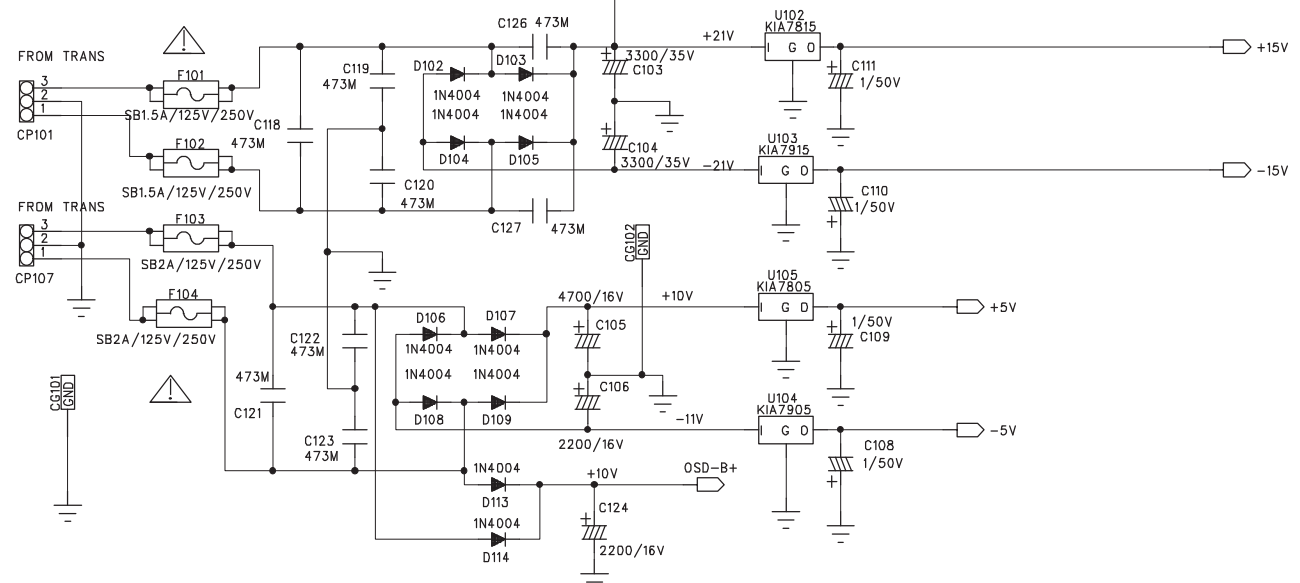
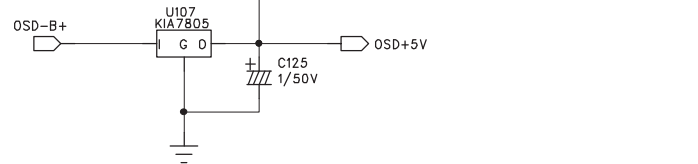
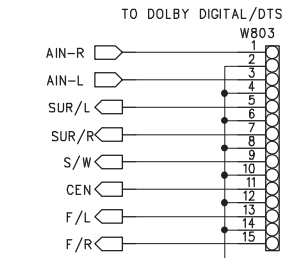
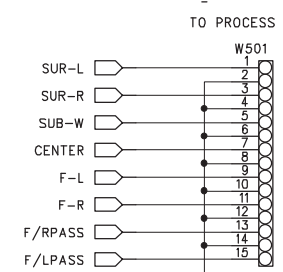
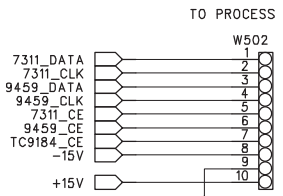
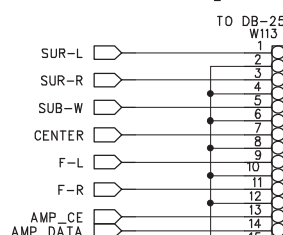
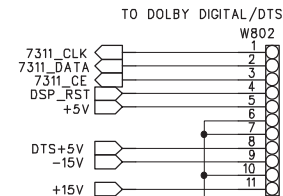
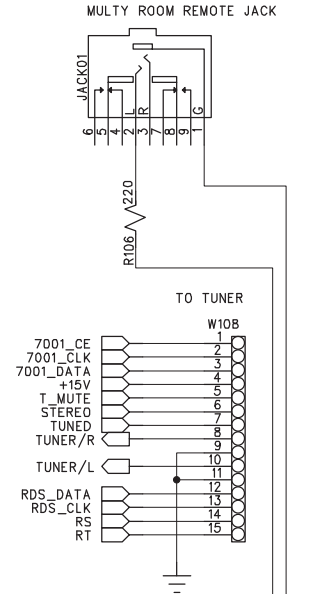
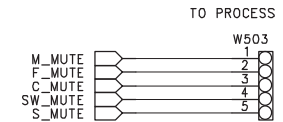
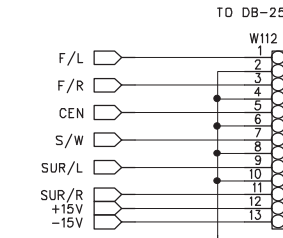
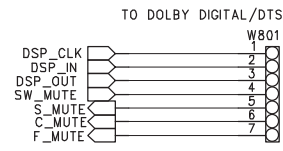
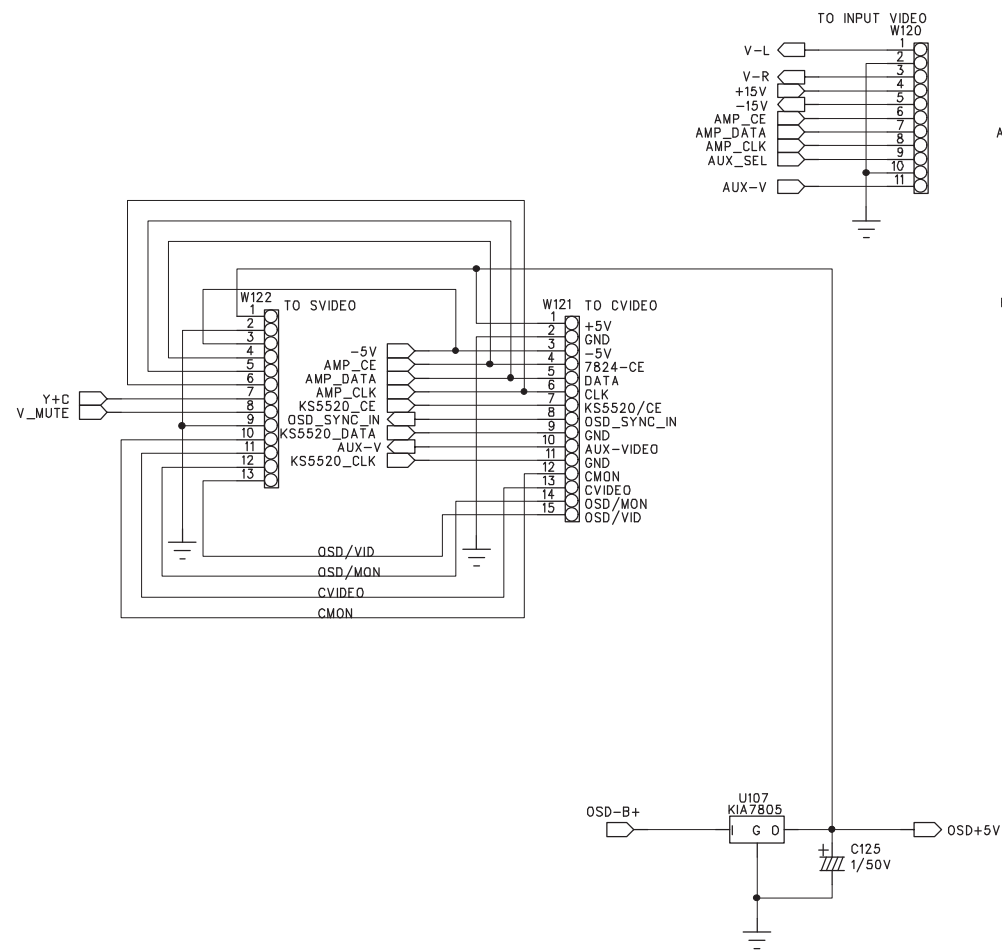

# Schematic Diagram

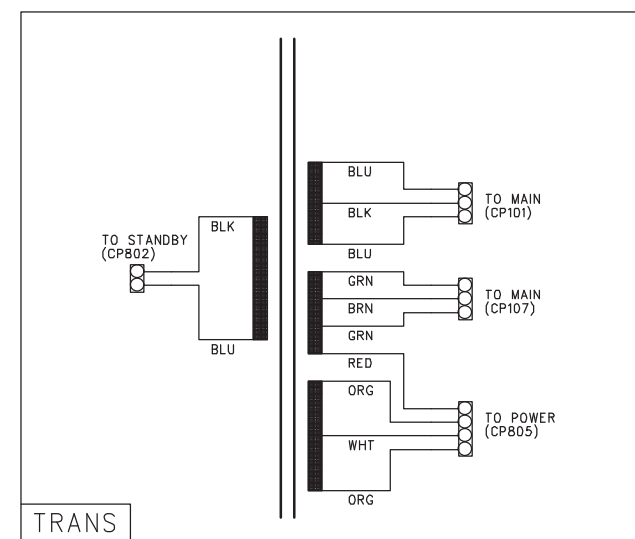
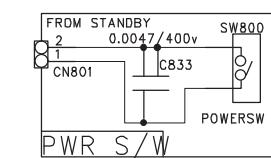
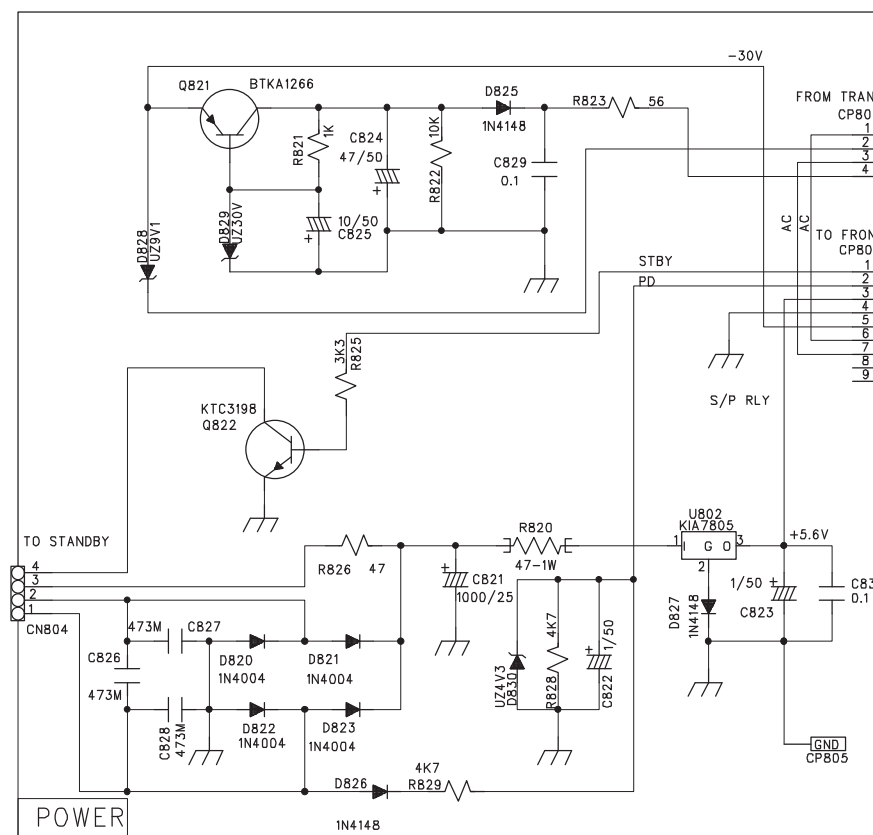
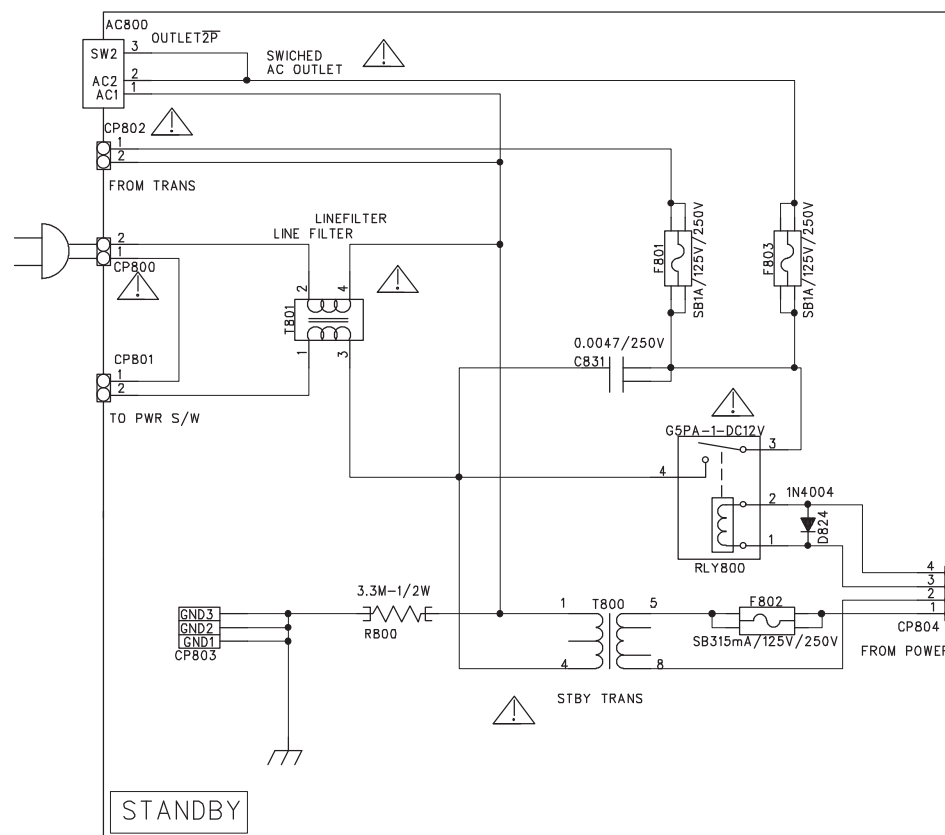
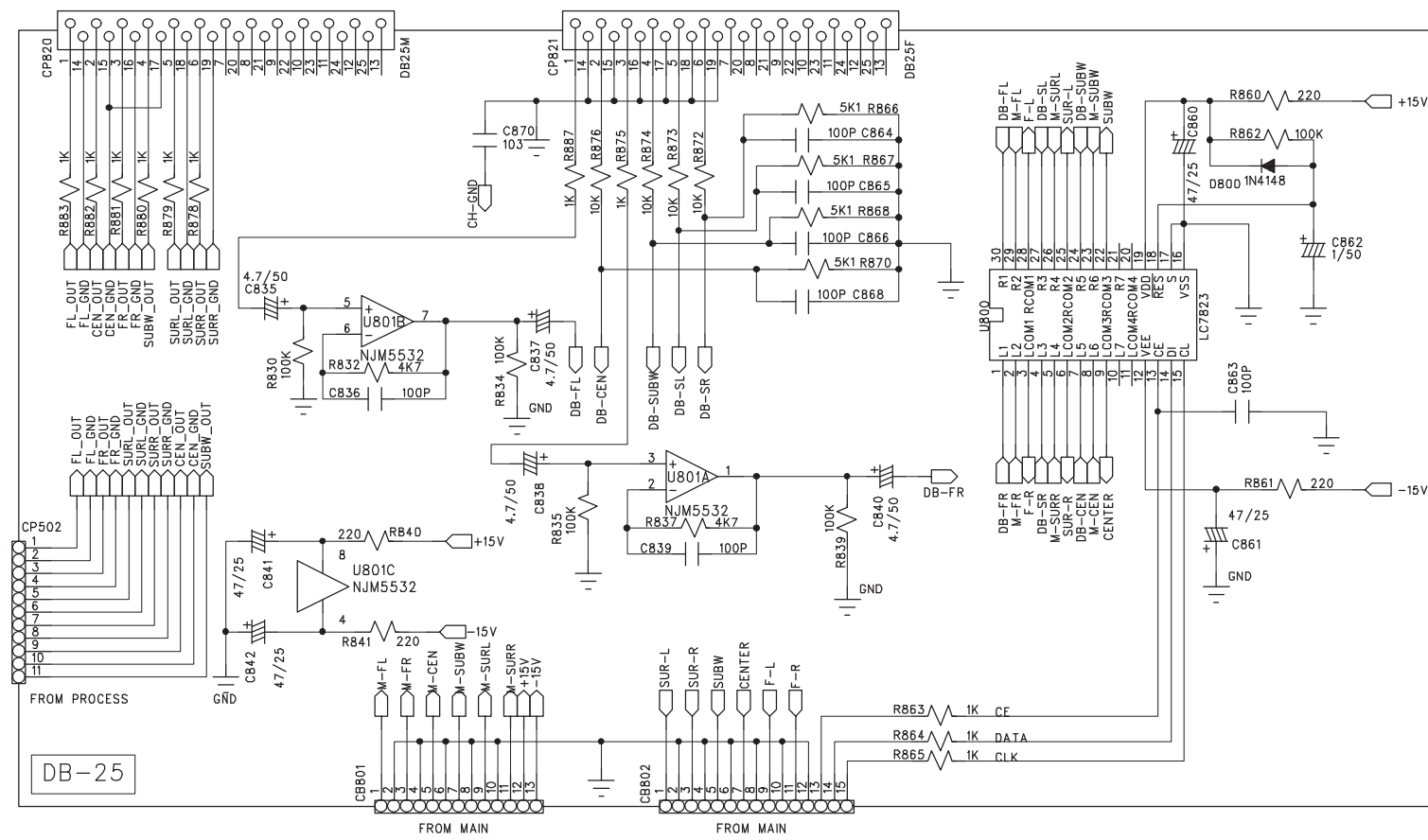

# Schematic Diagram

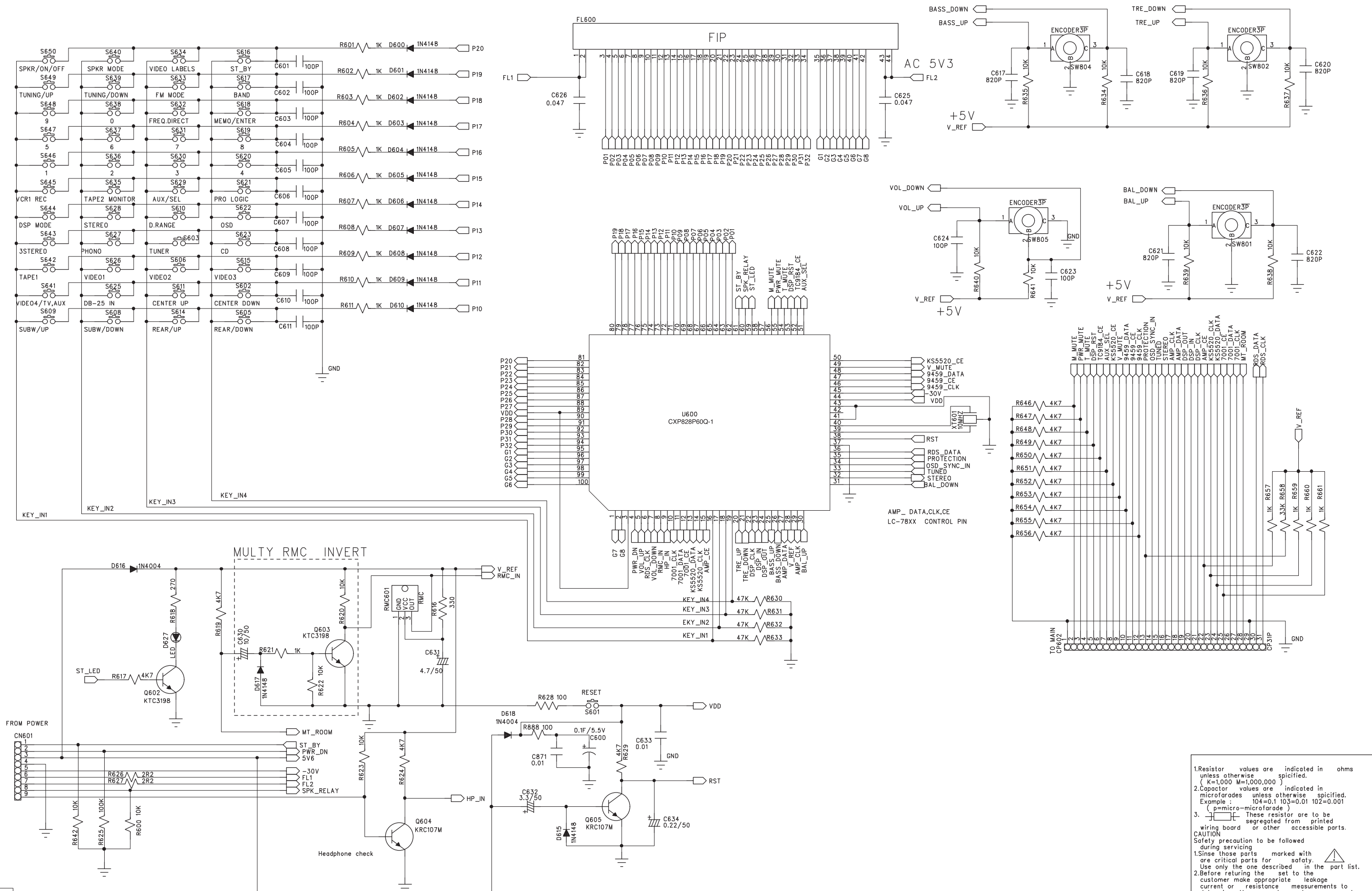

FRONT 4001000100

1. Resistor values are indicated in ohms unless otherwise specified. (K=1,000 M=1,000,000)  
 2. Capacitor values are indicated in microfarads unless otherwise specified. Example: 104=0.1 103=0.01 102=0.001 (p=micro-microfarad)  
 3. These resistor are to be segregated from printed wiring board or other accessible parts.  
**CAUTION**  
 Safety precaution to be followed during servicing  
 1. Since those parts marked with are critical parts for safety.  
 Use only the one described in the part list.  
 2. Before returning the set to the customer make appropriate leakage current or resistance measurements to determine the exposed parts are properly insulated from the supply circuit.

EQUIPMENT	DW. N.O.
-----------	----------



# Schematic Diagram

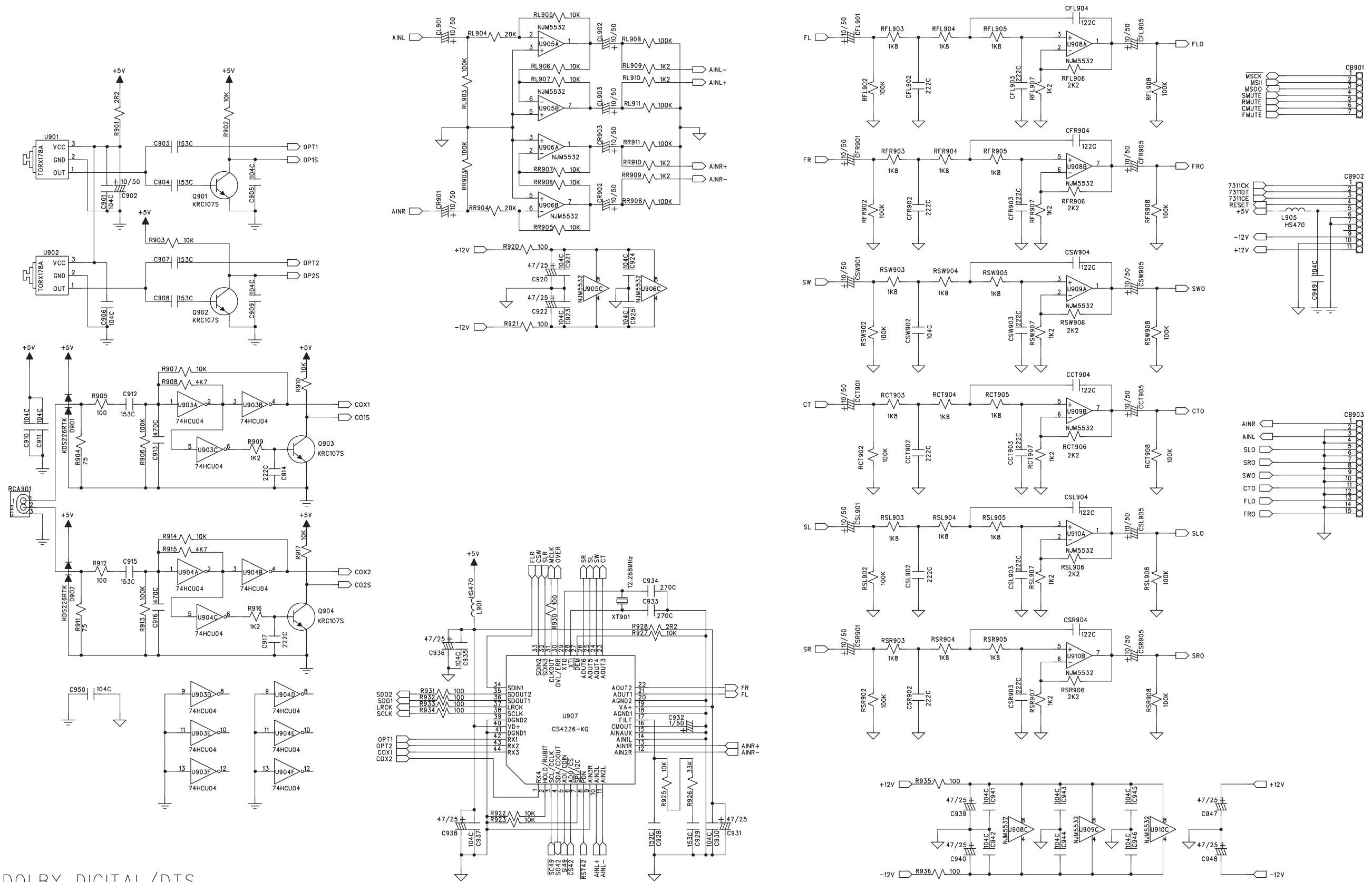

DOLBY DIGITAL/DTS  
4002001400 REV.D (1/2)

# Schematic Diagram

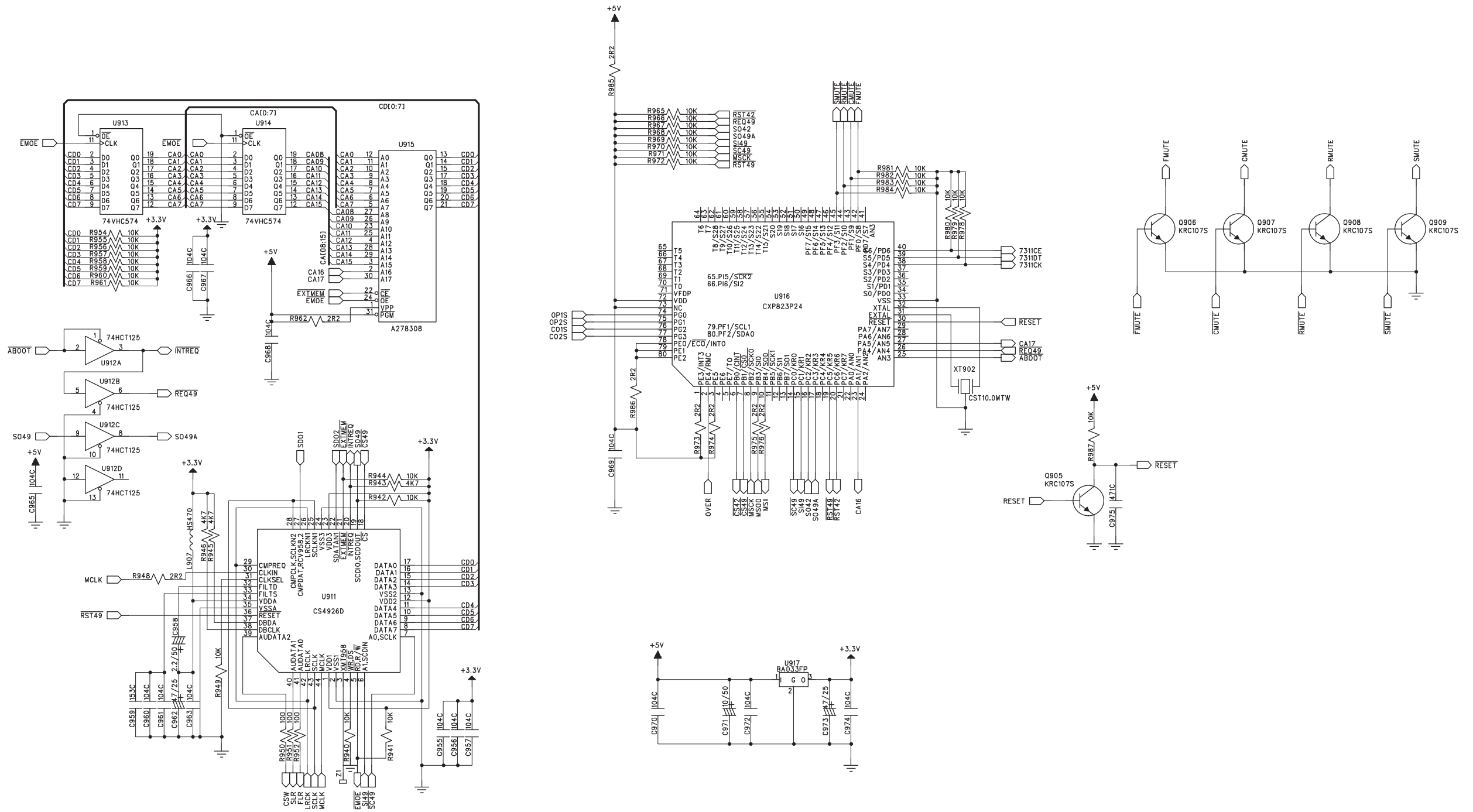

DOLBY DIGITAL/DTS  
4002001400 REV.D (2/2)



# Schematic Diagram

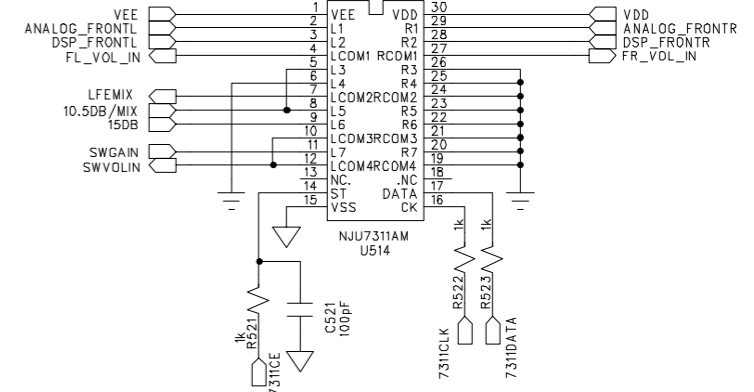
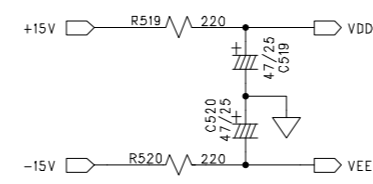
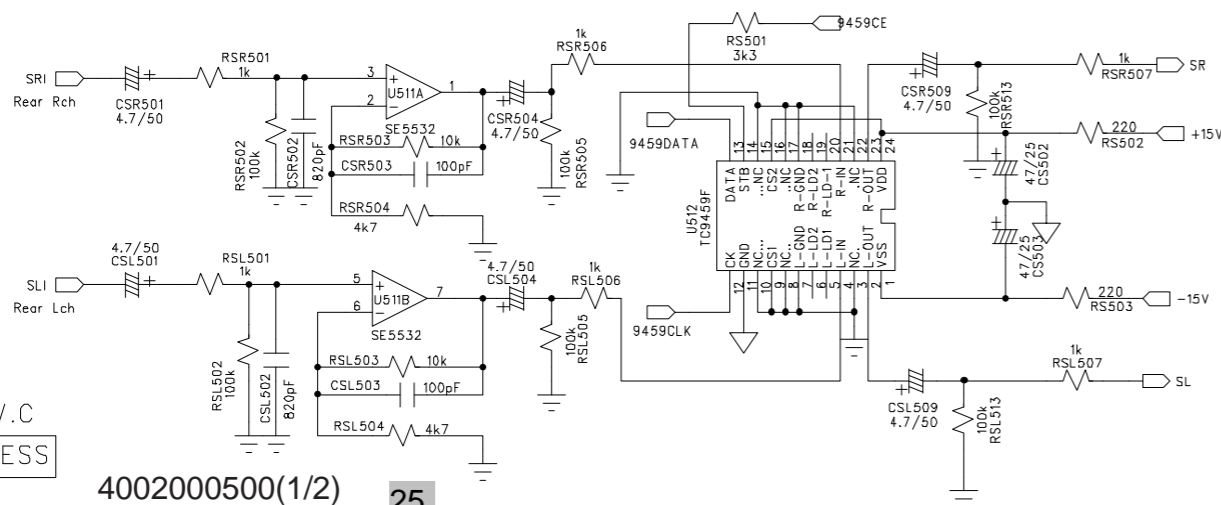
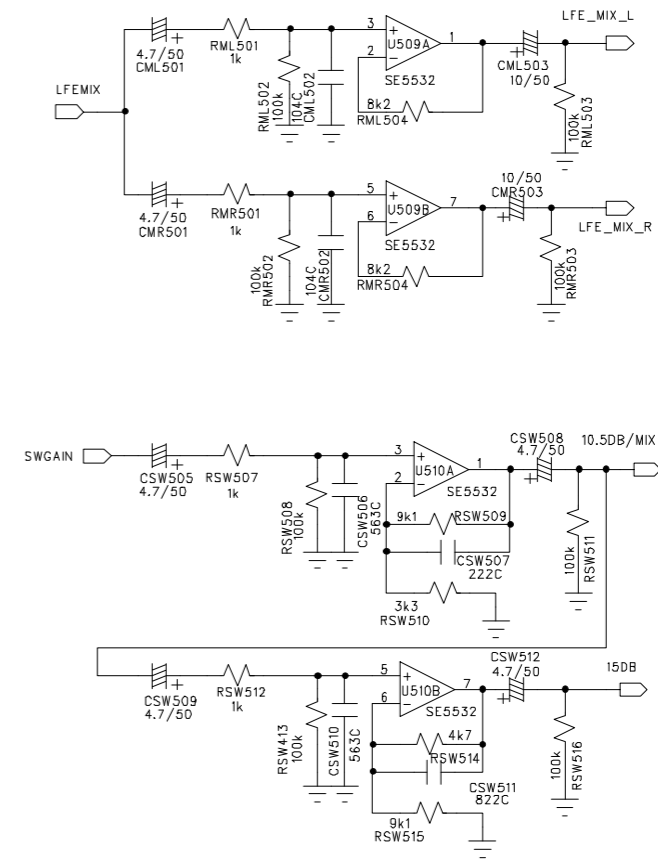
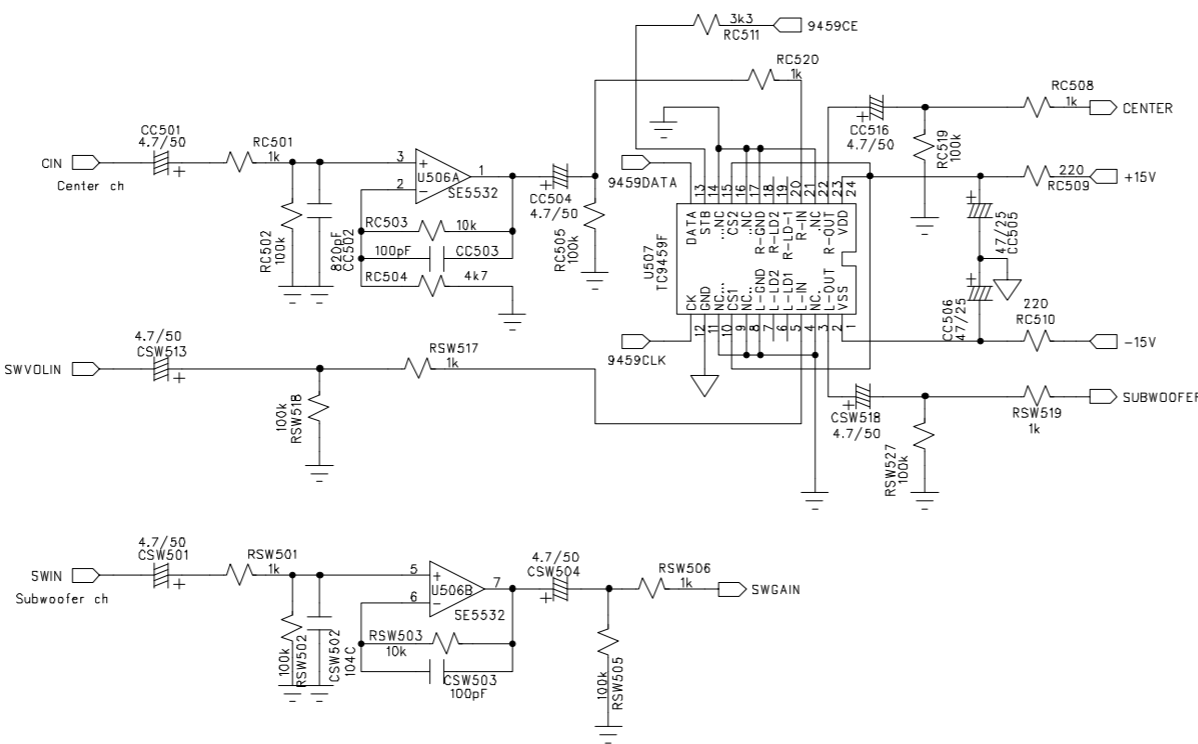
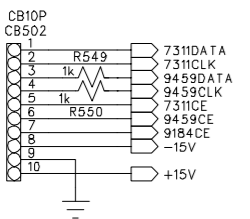
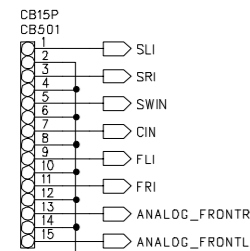
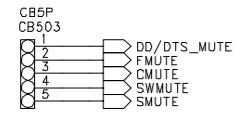
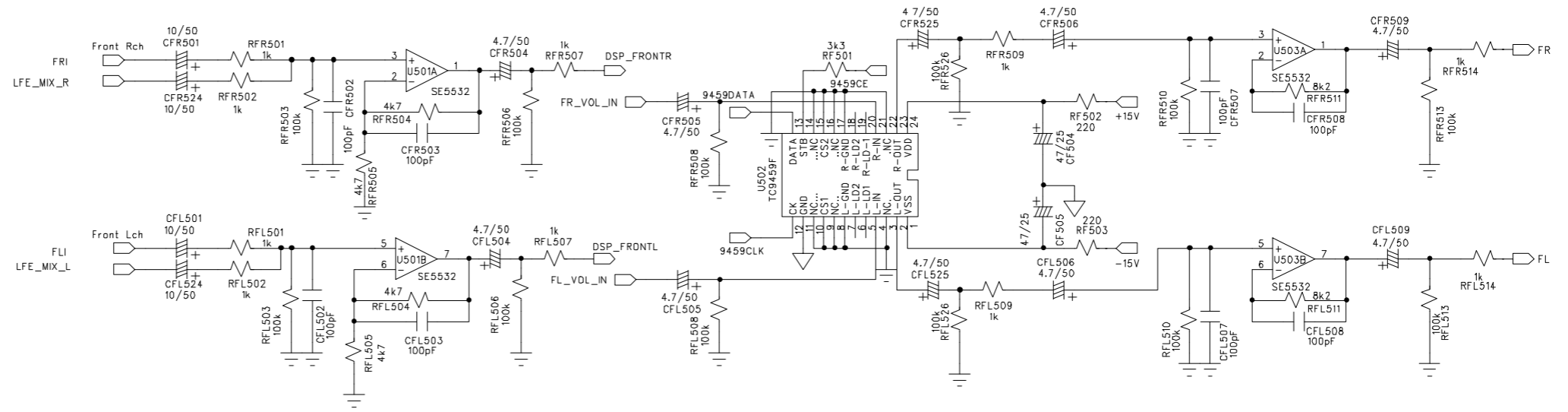

REV.C  
PROCESS

4002000500(1/2)

# Schematic Diagram

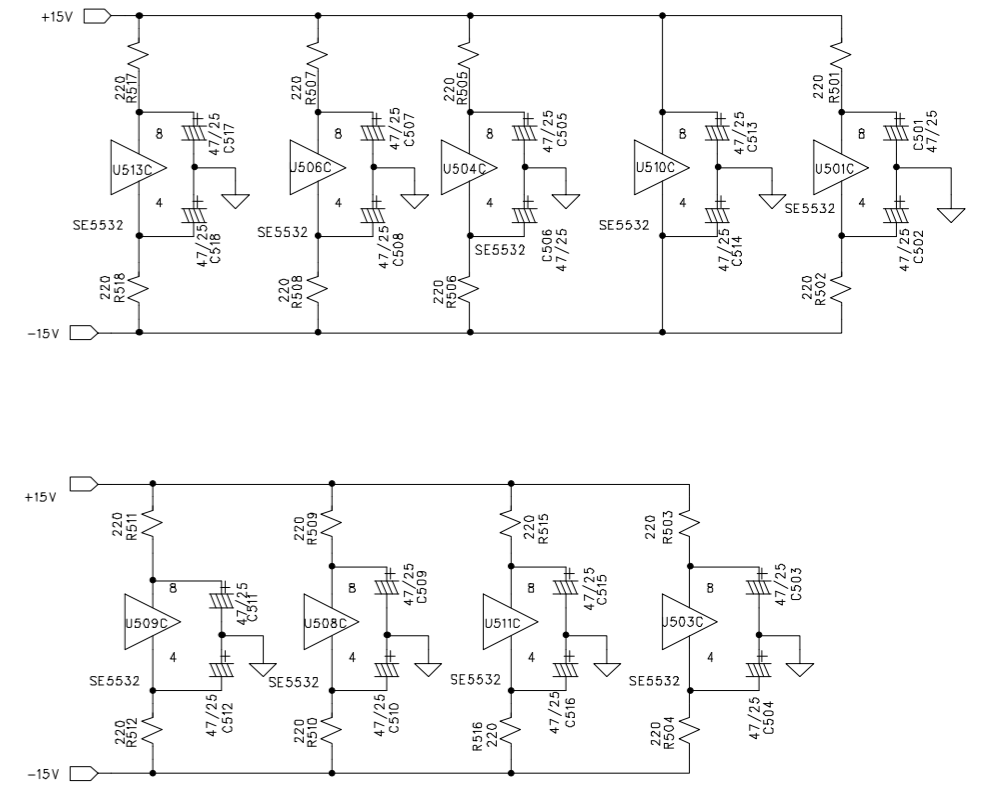
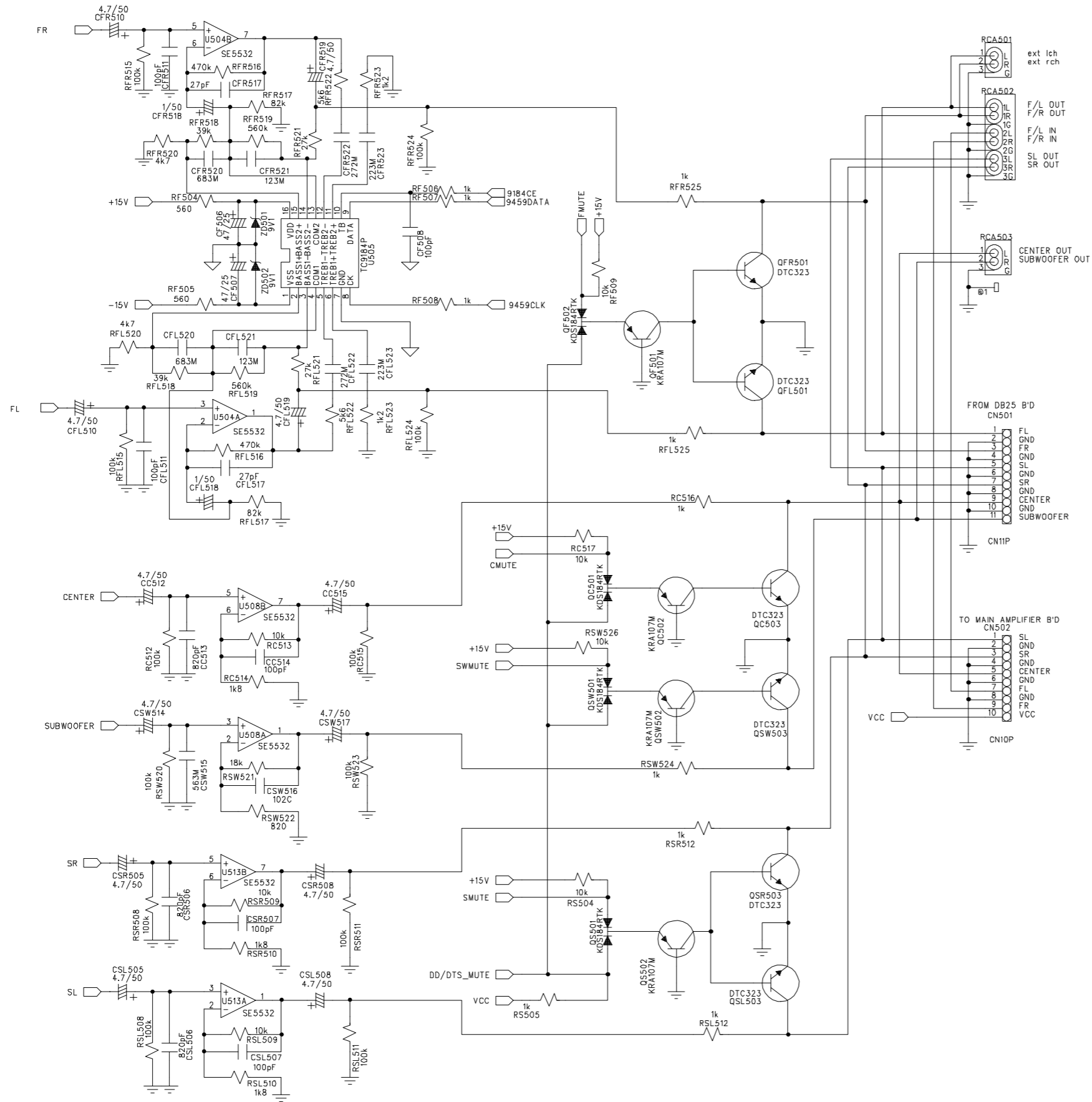

REV.C  
PROCESS

4002000500 (2/2)