



Technical Manual

SURROUND SOUND PROCESSOR **RSP-975**

Table of Contents

- Specification.....
- Parts List.....2~8
- PCB Assembly.....9~14
- Schematic Diagram15~20

THE ROTEL CO., LTD.
 SHINSEN-BLD. 4F 10-10 SHINSEN-CHO, SHIBUYA-KU,
 TOKYO 150-0045, JAPAN

Serial. NO. Beginning

Parts List (1/7)

SYMBOL	PART NO.	DESCRIPTION	SPECIFICATION
	651B2U56B21P	AC CORD	SPT-2 #18
	10DSI653601*	AC RECEPTACLE	S-I6536#01
	85A496*****	ACRY	A-496
	85AW863*****	ACRY (REMOTE)	AW-836
	85506*****	ACRYLIC LIGHT GUIDER	A-506
	85A491*****	ACRYLIC LIGHT GUIDER	A-491
	85A499*****	ACRYLIC LIGHT GUIDER	A-499
	85A488*****	ACRYLIC LIGHT GUIDER	A-488 8P
	75L64000206*	AL PLATE	L-640
	78C228801083	BOTTOM PLATE	C-2288
TRANSFORMER	78C206000587	BREASKET,U-TYPE	C-2060
	98BSB4F1K***	BUSHING	SB4F-1
	78C230301081	CHASSIS,LEFT	C-2303
	78C209501082	CHASSIS,RIGHT	C-2095
B2770 JP17 TO B2776 JP603	85A387*****	CONNECTOR	ED-A63 20P
B2770 JP9.J10.J3 TO B2771 JP702. B2771 JP701.B2776AV JP601	66HDA64*****	CONNECTOR	ED-A64 24P
TRANSFORMER	66HDA67*****	CONNECTOR	ED-A67 3P
TRANSFORMER	66HDA68*****	CONNECTOR	ED-A68 3P
TRANSFORMER	66HDA69*****	CONNECTOR	ED-A69 5P
	85A522*****	FILTER	A-522
	81A4TSH19***	FOOT CUSHION	4TSH-19#2
	78C209201078	FRONT PLATE	C-2092
AC120V UL/CSA, AC220V CE	2652000222*1	FUSE 5x20MM	2A/250V F 19193
	99IRSP975***	INSIDE CAPTON	RSP-975
	RSP975B2770*	KIT P.C.B	B2770
	RSP975B2771*	KIT P.C.B	B2771 KEY
	RSP975B2774D	KIT P.C.B	B2774-DSP
	RSP975B2774S	KIT P.C.B	B2774-SPK
	RSP975B2776*	KIT P.C.B	B2776 AV
	RSP975B2778*	KIT P.C.B	B2778 POWER
	80KB395*****	KNOB	KB-395
	80KB361*****	KNOB(TONE)	KB-361
	SCNEY7Φ****	NUT	VR ACCESSORIES
	85A4TR2797**	ORNAMENT END CAP	OMI-1284(4RT2797)
	99CRSP975***	OUTER CARTON	RSP-975
	85A581*****	PAD,SWITCH	A-581
RCA JACK	SCCR*P1809B*	PLASTIC SCREW	1/8x9
	98CS1828****	PLASTIE PCB SUPPORT	CS-1828
KB345.A-490.A-489	80KB345*****	POWER KNOB	KB-345
	80KB343*****	PUSH KNOB 5P	KB-343
	80KB342*****	PUSH KNOB 8P	KB-342
	85A358*****	PVC UPPER	SR-882
	78C231101085	REAR PLATE	C-2311
	78C229401080	REAR PLATE EUROP	C-2294
	78C229301079	REAR PLATE USA	C-2293
	SCCR*T3006B*	SCREW	CRTS 3x6 B
	SCCR*T3008B*	SCREW	CRTS 3x8 B
	SCCR*F3008Y*	SCREW	CRTS 3x8 W
	SCCR*T3006Y*	SCREW	CRTS 3x6 Y
	SCCR*M3006Y*	SCREW	CRMS 3x6 Y
KB345.A-490.A-489	854890*****	SHELL FRAGMENT	A-490
	94D143*****	SHIELD COVER	D-143
	250119*****	SNAP RIVET	SR355 3Φ
	94D146*****	SPONGE	D-146
	84D185*****	SPONGE,EVA	D-185 11x11x25
		STYROFOAM	PL-1063

Parts List (2/7)

SYMBOL	PART NO.	DESCRIPTION	SPECIFICATION
KB345.A-490.A-489	E63519M304*3	TRANSFORMER	E63519M304*3
	78C232801098	UPPER COVER	C-2328
	85489*****	WASHER	A-489
	SCNWWY7Φ****	WASHER,FLAT	VR ACCESSORIES
	85A583*****	WASHER,KNOB	A-583
ACCESSORIES			
	64T0006*****	1P RCA CABLE	1104002G-1
	64T0007*****	2P RCA CABLE	1104024G-1
	6604PSP975**	OWNER'S MANUAL	RSP-975
	62PR939*****	REMOTE CONTROL	RR-939
		WARRANTY STATEMENT	4TR-3043C
PCB B 2 7 7 0			
C1.2.3.15.17.21.84.85	490221HRKSDT	CAPACITOR CERAMIC	22P/50V SL/K
C43-65.74	491011HRKSDT	CAPACITOR CERAMIC	100P/50V SL/K
C106.107.110	494031HRZFDT	CAPACITOR CERAMIC	403/50V F/Z
C25.26.29.30.88.96.97.101	561041HRZFDT	CAPACITOR CERAMIC	104/50V
C72.73.102.114.117-121	404R71H0511T	CAPACITOR ELEC	4.7U/50V
C115	400101H0511T	CAPACITOR ELEC	1U/50V
C4-14.16.18-20.23.24.66-71.81.82.116	401001H0511T	CAPACITOR ELEC	10U/50V
C22	404701H6311T	CAPACITOR ELEC	47U/50V
C99	401011E6311T	CAPACITOR ELEC	100U/25V
C86.87.90.91.93.94.95.103.104	402211E8115T	CAPACITOR ELEC	220U/25V
C111	481011E1012T	CAPACITOR ELEC	100U/25V NP
C27.28.31.32	404711E1016T	CAPACITOR ELEC	470U/25V
C105	401021E1220B	CAPACITOR ELEC	1000U/25V
C100	564731CRKPTN	CAPACITOR ELEC	FMOH-473ETP (0.47F/16V)
C83	502031HRJENT	CAPACITOR MYLAR	203J/50V
J904 TO B2778 JP904	66HDA66*****	CONNECTOR	ED-A66 8P
J901 TO B2778 JP901	66HDA65*****	CONNECTOR	ED-A65 3P
X1	1708MHZ****B	CRYSTAL	8MHz
D7.8.9	131N4007****	DIODE	1N4007
D1-6	131N4148****	DIODE	1N4148
	131N4007****	DIODE	1N4007
JP2	66P110124BSK	EDGE CARD CONN	1101-24BSK 24P
Y1	21FILTER104*	EMI FILTER	EMIF 104
Y11.12.13.14.15.16	21FILTER101*	EMI FILTER	EMIF 101
U31.32.33.36.37	76H39600069*	HEAT SINK	H-397
U45	76H43900054*	HEAT SINK	H-439
U2.3.5.6.8.9.20.28	11NJM5532D*D	IC	NJM5532
U16.19.29.40.41.42	11NJU201AD*D	IC	NJU201AD
U17.21.22.47	11JRC4558DDD	IC	JRC4558D
U14	11HEF4021BP*	IC	HEF4021BP
U1.4.7.26	11TC9213***D	IC	TC9213
U15	11TC9163***D	IC	TC9163
U46	11DT5C114E*D	IC	DT5C114E
U30	11TC9713***D	IC	TC9713
U38	11M51951BSLB	IC	M51951B
U36	11AN7815***D	IC	AN7815
U37	11AN7915***D	IC	AN7915
U33	11AN7812***D	IC	AN7812
U32	11AN7905***D	IC	AN7905
U31.45	11AN7805***D	IC	AN7805
U30	10A64PBD****	IC SOCKER	64P
	60B2770*****	P.C.B	B2770
JP3.JP9.JP10	66P254224R**	PIN	2542-24P
JP17	66P254220R**	PIN	2542-20P

Parts List (3/7)

SYMBOL	PART NO.	DESCRIPTION	SPECIFICATION
JP4	66P254520R**	PIN	2545-20P FEMALE
JP5	66P254524R**	PIN	2545-24P FEMALE
J3.4.5.6.7.10	68HSP214V03*	RCA JACK	HSP-214V#3
J2	68HSP206V03*	RCA JACK	HSP-206V#3
R209	300010C4TJ2T	RESISTOR CARBON	1/4W T 10
R50.51.52.53	300022C4TJ2T	RESISTOR CARBON	1/4W T 22
R220.225	300680C4TJ2T	RESISTOR CARBON	1/4W T 680
R70	30010KC4TJ2T	RESISTOR CARBON	1/4W T 10K
R137	30100KC4TJ2T	RESISTOR CARBON	1/4W T 100K
R40-45.75-78.87-90	300330C8TJ2T	RESISTOR CARBON	1/8W T 330
R109.110-124	3001K5C8TJ2T	RESISTOR CARBON	1/8W T 1K5
R95.99.199.202	3002K2C8TJ2T	RESISTOR CARBON	1/8W T 2K2
R19-23.33.188-190.197.198.200.201.204-208.218.219	3004K7C8TJ2T	RESISTOR CARBON	1/8W T 4K7
R3.26-30.36.39.138.181.211.221.222.223.224	30010KC8TJ2T	RESISTOR CARBON	1/8W T 10K
R4.139.182.217	30022KC8TJ2T	RESISTOR CARBON	1/8W T 22K
R25.32.34.35.37.38	30033KC8TJ2T	RESISTOR CARBON	1/8W T 33K
R46.212	30047KC8TJ2T	RESISTOR CARBON	1/8W T 47K
R1.2.16-18.24.54-67.69.72.74.79-86.96.100.101	30100KC8TJ2T	RESISTOR CARBON	1/8W T 100K
R5-15.31.97.98.107.108	30180KC8TJ2T	RESISTOR CARBON	1/8W T 180K
R93.94	30330KC8TJ2T	RESISTOR CARBON	1/8W T 330K
R68.71	30820KC8TJ2T	RESISTOR CARBON	1/8W T 820K
R128.129	300010C2TJ5T	RESISTOR CARBON	1/2W T 10
PR1	29C41030504J	RESISTOR NETWORKS	10Kx4
PR4	29C44720908J	RESISTOR NETWORKS	4K7x8
PR2.PR3	29C42230504J	RESISTOR NETWORKS	22Kx4
PR001	29C44730908J	RESISTOR NETWORKS	47Kx8
Q8	SCCR*T3006Y*	SCREW	CRTS 3x6
Q1.9.12	122SA1015GRT	TRANSISTOR	2SA1015BL/GR
Q2-Q7	122SC1815BLT	TRANSISTOR	2SC1815BL/GR
JP1	122SC3327A*T	TRANSISTOR	2SC3327
	66W504507R**	WAFER	5045-7P
PCB B 2 7 7 1			
C702.705	561041HRZFDT	CAPACITOR CERAMIC	104/50V
C706	401011E6311T	CAPACITOR ELEC	100U/25V
D702	131N4148****	DIODE	1N4148
D703	131N4007****	DIODE	1N4007
DIS701	870PIN*****	HEADER PIN	SIB-105-S001-01
U707	11DT5C114E*D	IC	DT5C114E
U705.706	11DT5A114E*D	IC	DT5A114E
U702.703.704.708	1174HC595AED	IC	74HC595AP
IR701	15BX1407****	IR RECIEVER	BX1407
DIS701	18SDC0311GWA	LED	DC03-11GWA
LED711.713.714.716.717.723.729.730.731	18L934IT***B	LED	L-934IT
LED702-706.708.732	18L3XHT***B	LED	L-3XHT
LED701.718.719.720.721.722.725.726	18L3XGT***B	LED	L-3XGT
LED729	85A503*****	LED SPACER 1P	A-503
LED723.730.731	85A504*****	LED SPACER 3P	A-504
414MMx94.5MM	602771*****	P.C.B	B2771
JP701.702	66P254124R**	PIN	2541-24P 12x2
R708.709.710.711.712.713.714.715	300100C4TJ2T	RESISTOR CARBON	1/4W T 100
R717	300220C4TJ2T	RESISTOR CARBON	1/4W T 220
R701.702.703.704.705.706	300330C4TJ2T	RESISTOR CARBON	1/4W T 330
R722	300470C4TJ2T	RESISTOR CARBON	1/4W T 470
R723	3001K5C4TJ2T	RESISTOR CARBON	1/4W T 1K5
R726.728	300150C8TJ2T	RESISTOR CARBON	1/8W T 150
R729.731	300330C8TJ2T	RESISTOR CARBON	1/8W T 330
R732.733.736.737	300390C8TJ2T	RESISTOR CARBON	1/8W T 390

Parts List (4/7)

SYMBOL	PART NO.	DESCRIPTION	SPECIFICATION
R738.740.763	300560C8TJ2T	RESISTOR CARBON	1/8W T 560
R742	300680C8TJ2T	RESISTOR CARBON	1/8W T 680
R744	300750C8TJ2T	RESISTOR CARBON	1/8W T 750
R746	300820C8TJ2T	RESISTOR CARBON	1/8W T 820
R764	30001KC8TJ2T	RESISTOR CARBON	1/8W T 1K
R748	3001K2C8TJ2T	RESISTOR CARBON	1/8W T 1K2
R724	3001K5C8TJ2T	RESISTOR CARBON	1/8W T 1K5
R752.753.754.755.756,757	3004K7C8TJ2T	RESISTOR CARBON	1/8W T 4K7
R719.720	30010KC8TJ2T	RESISTOR CARBON	1/8W T 10K
R762	30039KC8TJ2T	RESISTOR CARBON	1/8W T 39K
R761	30100KC8TJ2T	RESISTOR CARBON	1/8W T 100K
PR601	29C41030908J	RESISTOR NETWORKS	10Kx8
TSW701-TSW712.TSW717.TSW718	20GB3F1050**	TACT SWITCH	B3F-1050
Q702.703	122SC1815BLT	TRANSISTOR	2SC1815GR/BL
PCB B 2 7 7 9			
	78C244301152	BREAKET	C-2443
B2779 J703 TO B2771 JP703	66F04060****	FLAT CABLE	4P 60MM
	11TC74HC74AP	IC	TC74HC74AP
		PVC WIRE	#26 50MM RED
S701	20EC16B24102	RATATE SWITCH	EC16B24102
R1.R2	30010KC8TJ2T	RESISTOR CARBON	1/8W T 10K
PCB B 2 7 7 4 - SPK			
C952.953.972	491011HRKSdT	CAPACITOR CERAMIC	100P/50V SL/K
C966.967	561041HRZFDT	CAPACITOR CERAMIC	104/50V
C965.964	402211E8115T	CAPACITOR ELEC	220U/25V
C951	501021HRJEMT	CAPACITOR MYLAR	102J/50V MIIN SIZE
C968	508231HRJEMT	CAPACITOR MYLAR	823J/50V MINI SIZE
C971	503331HRJEMT	CAPACITOR MYLAR	333J/50V MINI SIZE
D900.901	131N4148****	DIODE	1N4148
U900-904.U911-913	11JRC4558DDD	IC	JRC4558D
U905-910	11NJU201AD*D	IC	NJM201A
	60B2774****	P.C.B	B2774-SPK
R943.944	300100C4TJ2T	RESISTOR CARBON	1/4W T 100
R912.914.916	3002K2C8TJ2T	RESISTOR CARBON	1/8W T 2K2
R918.923.927	3002K7C8TJ2T	RESISTOR CARBON	1/8W T 2K7
R900.901.902.908.909	3004K7C8TJ2T	RESISTOR CARBON	1/8W T 4K7
R920.921	3006K8C8TJ2T	RESISTOR CARBON	1/8W T 6K8
R907.910.922.924.925.926.948.953.955	30010KC8TJ2T	RESISTOR CARBON	1/8W T 10K
R931.932.933.935.937.939.950	30012KC8TJ2T	RESISTOR CARBON	1/8W T 12K
R906.917.949.951	30015KC8TJ2T	RESISTOR CARBON	1/8W T 15K
R903.904.905.929.941.942	30018KC8TJ2T	RESISTOR CARBON	1/8W T 18K
R934.936.938.940.945.946.947.952.954	30022KC8TJ2T	RESISTOR CARBON	1/8W T 22K
R930	30047KC8TJ2T	RESISTOR CARBON	1/8W T 47K
R911.913.915.928	30100KC8TJ2T	RESISTOR CARBON	1/8W T 100K
C950.954.955.956.957.958.959.960.961.962.969	570R11H0606T	RESISTOR M.O.F	104/50V
R970	57R221H0605T	RESISTOR M.O.F	224/50V
Q901-Q905	122SC1815BLT	TRANSISTOR	2SC1815BL
PCB B 2 7 7 4 - DSP			
C838.916	561031HCZFST	CAPACITOR CERAMIC	103/50V 0805
C825.837.840.841.848-850.854-875.894.897.898.902.903.905.915.917-921.924-927.974.975.976.980.981.982.997.998	561041HCZFST	CAPACITOR CERAMIC	104/50V 0805
C801.803.843	560101HCKSKST	CAPACITOR CERAMIC	10P/50V 0805
C808.813.819.827.833.851	563911HCKSSST	CAPACITOR CERAMIC	390P/50V 0805
C830	564711HCKSSST	CAPACITOR CERAMIC	470P/50V 0805
C810.815.821.829.835.853	565601HCKBST	CAPACITOR CERAMIC	560P/50V 0805
C877	564731HCZFST	CAPACITOR CERAMIC	473/50V 0805

Parts List (5/7)

SYMBOL	PART NO.	DESCRIPTION	SPECIFICATION
C923.922	560221HCKSSST	CAPACITOR CERAMIC	22P/50V 0805
C912.913	563321HCZFST	CAPACITOR CERAMIC	332/50V 0805
C807.809.812.814.818.820.826.828.832.834.847.852	564721HCZFST	CAPACITOR CERAMIC	472/50V 0805
C806.817.823.824.831.845.879.895.910.911.977.978	461001C0450T	CAPACITOR ELEC	10U/16V
C842.846.876.878.881.882.886.887.891.892.901.904.906	463301A0555T	CAPACITOR ELEC	33U/10V
C802.804.844	464700J0555T	CAPACITOR ELEC	47U/6.3V
C914.880	401011E6311T	CAPACITOR ELEC	100U/25V
C839.896.899	402211E8115T	CAPACITOR ELEC	220U/25V
C985.986.987.988.989.990	502031HRJENT	CAPACITOR MYLAR	203J/50V
L801.802.803	73C047UH****	CHOKE	47uH
L804	73C100UHP3A*	CHOKE	100uH
X801	17OSC33MHZ*B	CRYSTAL	OSC 33MHZ KTS
X802	1612P288***B	CRYSTAL	12.288MHZ
EMI801	21FILTER104*	EMI FILTER	EMIF 104
EMI802-EMI805	21FILTER101*	EMI FILTER	EMIF 101
Y801-805	73B3C2T7P5P8	FERRITE BEAD	3.5Tx7.5Φx0.8M
U801-U805.824.U832-U835	11NJM4558**S	IC SMD	NJM4558
U806.828.829.831	1174HCU04DTS	IC SMD	74HCU04DT
U807	11CS8412CS*S	IC SMD	CS8412
U808	1174HC595DTS	IC SMD	74HC595DT
U809	1174HC02DT*S	IC SMD	74HC02DT
U810	1174HC74DT*S	IC SMD	74HC74DT
U811	1174HC123DTS	IC SMD	74HC123DT
U813	11ZR38500PQS	IC SMD	ZR38500
U814	1174HC125DTS	IC SMD	74HC125DT
U815.816.817	11PCM1710U*S	IC SMD	PCM1710U
U822	1174HC257DTS	IC SMD	74HC257DT
U818.819.820	11AS7C25620S	IC SMD	AS7C256
U826	11HD74HC08DT	IC SMD	74HC08DT
U830	11AK5351VF*D	IC SMD	AK5351
LED801	18L32HD****B	LED	L-32HD
IR801	14TORX176***	OPTICAL RECIEVER	TORX176
	60B2774*****	P.C.B	B2774-DSP
TP801.TP802	66P254105R**	PIN	2541-5P
JP801	66P254120V**	PIN 10x2	2541-20P 90°C
JP802	66P254124V**	PIN 12x2	2541-24P 90°C
J801	68HSP253V515	RCA JACK	HSP-253V5-15
	30001KC8TJ2T	RESISTOR CARBON	1/8W T 1K
R857.858	300022C4TJ2T	RESISTOR CARBON	1/4W T 22
R873	300022C8SJ8T	RESISTOR CARBON	0805 22
R802.806.841	300075C8SJ8T	RESISTOR CARBON	0805 75
R852.853.854.860	300150C8SJ8T	RESISTOR CARBON	0805 150
R956.957.958.959.960.961	300680C8SJ8T	RESISTOR CARBON	0805 680
R804.808.843.845.846	30001KC8SJ8T	RESISTOR CARBON	0805 1K
R815.824.832.859.872.881	3003K6C8SJ8T	RESISTOR CARBON	0805 3K6
R809.810.812.817.818.820.826.827.829.834.835.837 .856.864.865.868.875.976.878.884.885-888.890	3004K7C8SJ8T	RESISTOR CARBON	0805 4K7
R811.819.828.836.867.877	3006K8C8SJ8T	RESISTOR CARBON	0805 6K8
R813.816.821.830.833.838.844.847.849.851.8 66.869.870.879.962.963.964	30010KC8SJ8T	RESISTOR CARBON	0805 10K
R848.850	30012KC8SJ8T	RESISTOR CARBON	0805 12K
R855	30018KC8SJ8T	RESISTOR CARBON	0805 18K
R823	30022KC8SJ8T	RESISTOR CARBON	0805 22K
R803.807.842.861.862.863.874.882.883	30047KC8SJ8T	RESISTOR CARBON	0805 47K
R814.822.831.839.871.880	30100KC8SJ8T	RESISTOR CARBON	0805 100K
R825	30001MC8SJ8T	RESISTOR CARBON	0805 1M
PR801	29C41030504J	RESISTOR NETWORKS	10Kx4

Parts List (6/7)

SYMBOL	PART NO.	DESCRIPTION	SPECIFICATION
Q801-807	122SC2712Y*S	TRANSISTOR SMD	2SC2712 LY
Q906	122SA1162Y*S	TRANSISTOR SMD	2SA1162 SY
PCB B 2 7 7 (AV) (DB)			
C622	490151HRJNDT	CAPACITOR CERAMIC	15P/50V SL/K
C640.641	490221HRKSdT	CAPACITOR CERAMIC	22P/50V SL/K
C639.650.651.652.653	490331HRKSdT	CAPACITOR CERAMIC	33P/50V SL/K
C670.672.674.676.678.680	491011HRKSdT	CAPACITOR CERAMIC	100P/50V SL/K
C609.610	495611HRKBdT	CAPACITOR CERAMIC	560P/50V SL/K
C613.614.618.621.625.630.658.661-665.682-685	561041HRZFDT	CAPACITOR CERAMIC	104/50V
C620.627.654.657	400101H0511T	CAPACITOR ELEC	1U/50V
C659.660.632	404R71H0511T	CAPACITOR ELEC	4.7U/50V
C656	443R31H0511T	CAPACITOR ELEC	3.3U/50V KULR
C671.673.675.677.679.681.	401001H0511T	CAPACITOR ELEC	10U/50V
C601-607.623.624.	404701C0511T	CAPACITOR ELEC	47U/16V
C636.637	401011E6311T	CAPACITOR ELEC	100U/25V
C615	402211C8115T	CAPACITOR ELEC	220U/16V
C611.612	404711C1012T	CAPACITOR ELEC	470U/16V
C655	502221HRJENT	CAPACITOR MYLAR	222J/50V
C619,642.646.647.649	503321HRJENT	CAPACITOR MYLAR	332J/50V
C617	501031HRJENT	CAPACITOR MYLAR	103J/50V
C631.638	502031HRJENT	CAPACITOR MYLAR	203J/50V
C643.644.645.648	503331HRJENT	CAPACITOR MYLAR	333J/50V
C616	501041HRJENT	CAPACITOR MYLAR	104J/50V
EMI601-EMI606	21FILTER101*	CERAMIC FILTER	101
L601	73C022UH****	CHOKER	22uH
B2776TO JP602	66HD895*****	CONNECTOR	ED-895 7P
Y601	1617P734475M	CRYSTAL	17.734475MHZ
Y602	1614P31818UB	CRYSTAL	14.31818MHZ
J606 NUTx2	68DBR25STKO*	DB25 JACK FEMALE	DBR25FTKO
D601.602.604-611	131N4148****	DIODE	1N4148
D601.604-611	131N4148****	DIODE	1N4148
U601	11LVA519S**D	IC	LVA519S
U603	11LA7951***D	IC	LA7951
U605	11HD74HC00PD	IC	HD74HC00P
U604	11NJM5532D*D	IC	NJM5532/JRC5532
U602	11UPD6458**S	IC SMD	UPD6458GT-101
J605	60B2776*****	P.C.B	B2776(TO)(DB)
IS601	10EHT03512EB	PHONE JACK	HTJ-035-12EB
B2776DB JP603	11LTV817C**D	PHOTO TRANSISTOR	LTV-817
JP601	66P254120R**	PIN 10x2	2541-20P 10x2
J601-J604	66P254124R**	PIN 12x2	2541-24P 12x2
R613.614	68HSP252V312	RCA JACK	HSP-252V3-12 2P
R640.666	300010C4TJ2T	RESISTOR CARBON	1/4W T 10
R623.625.631	300056C4TJ2T	RESISTOR CARBON	1/4W T 56
R621.622.624.630	300068C4TJ2T	RESISTOR CARBON	1/4W T 68
R634	300075C4TJ2T	RESISTOR CARBON	1/4W T 75
R626-629	300100C4TJ2T	RESISTOR CARBON	1/4W T 100
R632.633.636.638	300220C4TJ2T	RESISTOR CARBON	1/4W T 220
R604.615.616.617.618	3001K2C4TJ2T	RESISTOR CARBON	1/4W T 1K2
R654	3002K2C4TJ2T	RESISTOR CARBON	1/4W T 2K2
R659	3006K8C4TJ2T	RESISTOR CARBON	1/4W T 6K8
R661	30010KC4TJ2T	RESISTOR CARBON	1/4W T 10K
R643	30047KC4TJ2T	RESISTOR CARBON	1/4W T 47K
R655.658	30680KC4TJ2T	RESISTOR CARBON	1/4W T 680K
R610	300100C8TJ2T	RESISTOR CARBON	1/8W T 100
R660.662	300560C8TJ2T	RESISTOR CARBON	1/8W T 560
	3001K8C8TJ2T	RESISTOR CARBON	1/8W T 1K8

Parts List (7/7)

SYMBOL	PART NO.	DESCRIPTION	SPECIFICATION
R608.609	3002K2C8TJ2T	RESISTOR CARBON	1/8W T 2K2
R605	3002K7C8TJ2T	RESISTOR CARBON	1/8W T 2K7
R670.673.675.677.679.681	3003K3C8TJ2T	RESISTOR CARBON	1/8W T 3K3
TVR2	3004K7C8TJ2T	RESISTOR CARBON	1/8W T 4K7
R663	3005K6C8TJ2T	RESISTOR CARBON	1/8W T 5K6
R652	3006K8C8TJ2T	RESISTOR CARBON	1/8W T 6K8
R601	3008K2C8TJ2T	RESISTOR CARBON	1/8W T 8K2
R647-651.653	30010KC8TJ2T	RESISTOR CARBON	1/8W T 10K
R602	30027KC8TJ2T	RESISTOR CARBON	1/8W T 27K
R637.TVR3	30033KC8TJ2T	RESISTOR CARBON	1/8W T 33K
R639	30062KC8TJ2T	RESISTOR CARBON	1/8W T 62K
R644	30068KC8TJ2T	RESISTOR CARBON	1/8W T 68K
R642.645.646.664.665.671.672.674.676.678.680	30100KC8TJ2T	RESISTOR CARBON	1/8W T 100K
R619	30120KC8TJ2T	RESISTOR CARBON	1/8W T 120K
R606	30390KC8TJ2T	RESISTOR CARBON	1/8W T 390K
R656.657	30001MC8TJ2T	RESISTOR CARBON	1/8W T 1M
R603	39001002MJ*B	RESISTOR M.O.F	2W 10
SW601.602.603.605	20DT8019LTNQ	TOGGLE SWITCH	8019L 3P
SW604	20DA124T05**	TOGGLE SWITCH	8020L 3P
Q608	122SA970BL*T	TRANSISTOR	2SA970BL
Q601.602.603.605.607	122SC2240BLT	TRANSISTOR	2SC2240BL
C608	591TP8P*****	TRIMMER	1TP-8P
TVR1	31030006H***	TVR	6Φ H-TYPE 3P 300
VR601.602	36163121A312	VR 100KBx2	RK163121A312
PCB B 2 7 7 8 (PW)			
C901.902.903.904	491032HRZFDT	CAPACITOR CERAMIC	0.01/500V F/Z
C906.907.908.915.919.920	494732ARZFDT	CAPACITOR CERAMIC	0.047/100V
C914	402211E8115T	CAPACITOR ELEC	220U/25V
C913	404711E1016T	CAPACITOR ELEC	470U/25V
C916	402221E1625B	CAPACITOR ELEC	2200U/25V
C917.918	402221V1635B	CAPACITOR ELEC	2200U/35V
C909	404721E1831B	CAPACITOR ELEC	4700/25V
C905 EUROP	591042EWCRKF	CAPACITOR MEX	FXK 0.1/250V
C921	594722ERKCBW	CAPACITOR VDE	472/250V
L901 EUROP	73CRDS2P6P4M	CHOKE	RDS 2.6 - 0.4mH
D901.902.D905.908	131N4007****	DIOSE	1N4007
F901-904	67A05*****T	FUSE HOLDER	PF5000-0202 5Φ
U901	76H39700069*	HEAT SINK	H-397
U901	111N7805***D	IC	AN7805
	60B2778*****	P.C.B	B2778
I902	11LTV817C**D	PHOTO-TRANSISTOR	LTV-817
D906.907	13BR62*****	RECTIFIER	BR62
RY901	74MX112VDC**	RELAY	MX1 DC12V
RY902.903	74G2R2A*****	RELAY	G2R-2A 12VDC
R905	300330C4TJ2T	RESISTOR CARBON	1/4W T 330
R907.908	3004K7C4TJ2T	RESISTOR CARBON	1/4W T 4K7
R906.909	30010KC4TJ2T	RESISTOR CARBON	1/4W T 10K
R901 USA	353P3MC2TJ**	RESISTOR CARBON	1/2W T 3.3M
R910 EUROP	3204M7C2TF5T	RESISTOR METAL	1/2W T 4.7M
U901	SCCR*T3006Y*	SCREW	CRTS 3x6 Y
Q902	122SA1015BLT	TRANSISTOR	2SA1015BL/GR
Q903	122SA965Y**T	TRANSISTOR	2SA965Y
JP906	66W396103R**	WAFER	3961-3P
JP902	66W396305R**	WAFER	3963-5P
JP901.905	66W504503R**	WAFER	5045-3P
JP903	66W504505R**	WAFER	5045-5P
JP904	66W504508R**	WAFER	5045-8P

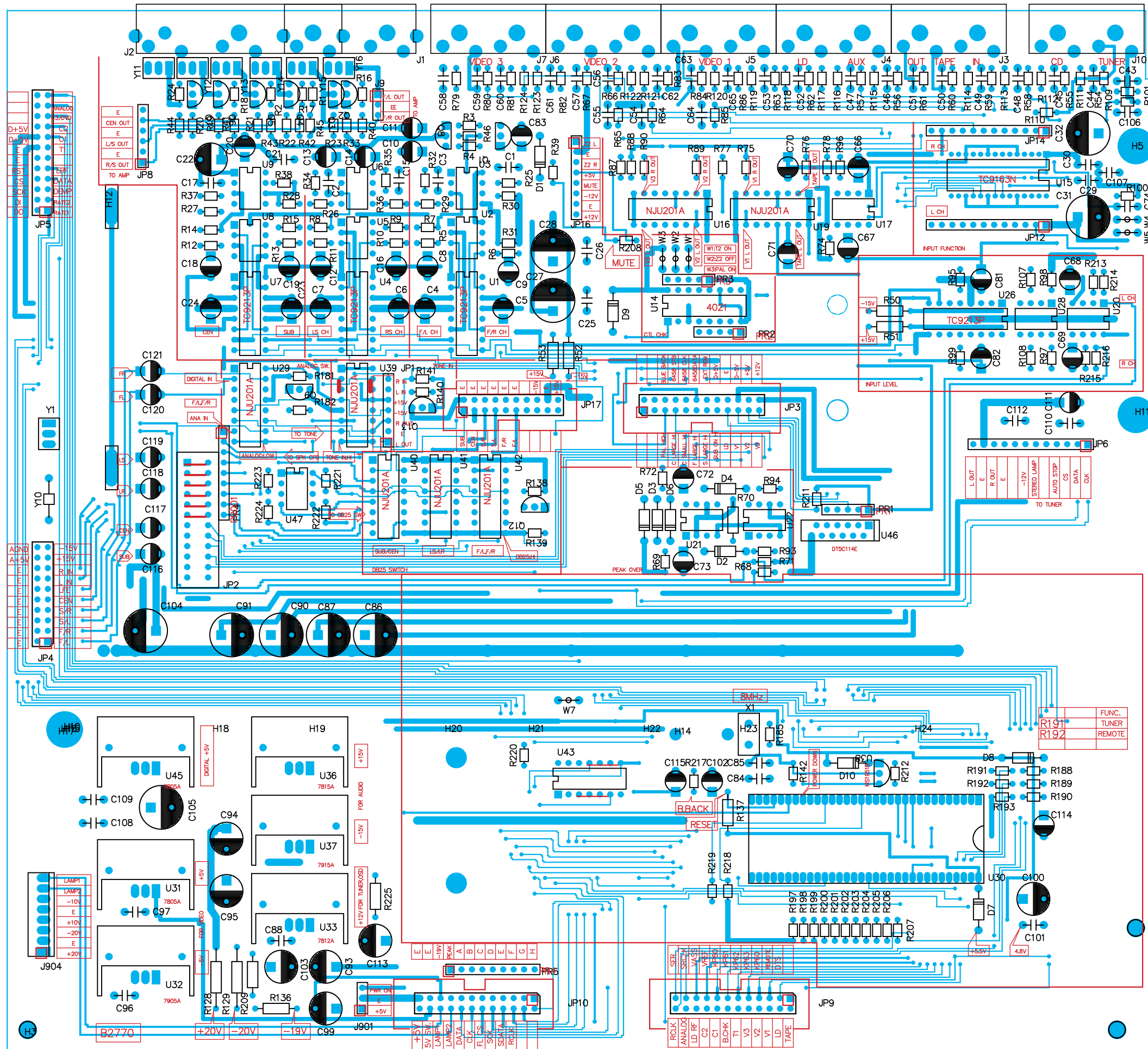

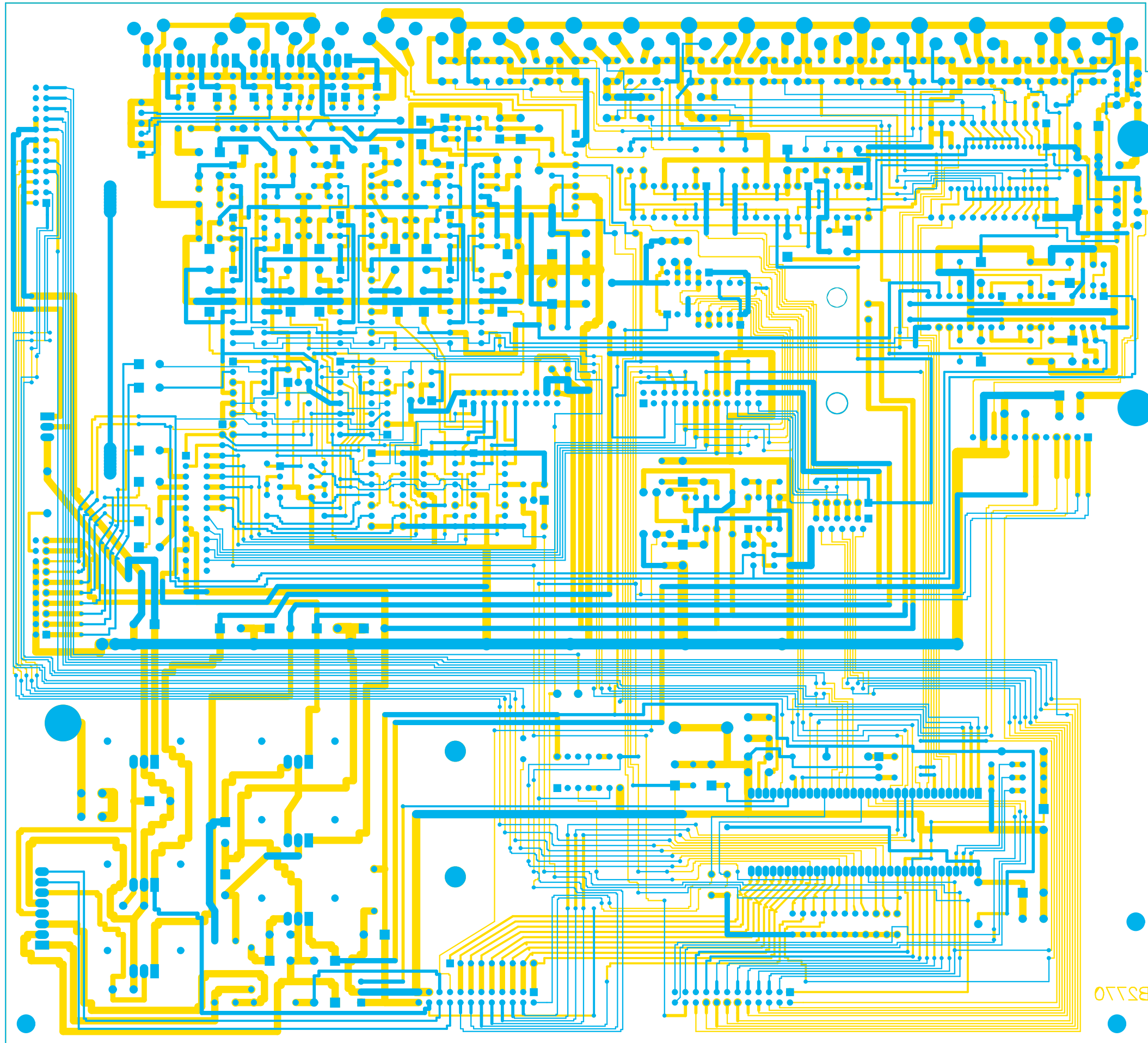

B2770

PCB Assembly

B2774 Top Side

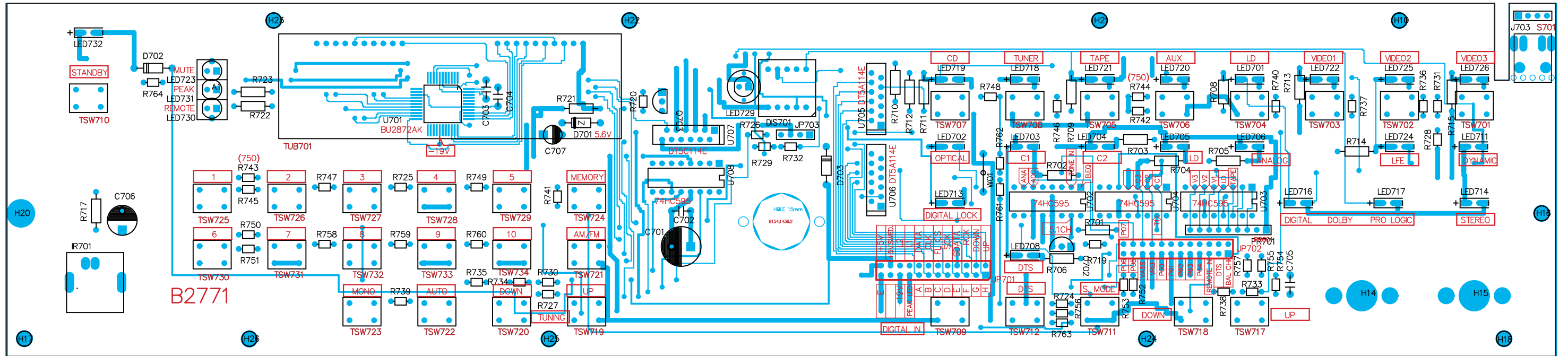

B2774 Patterns of Top and Bottom

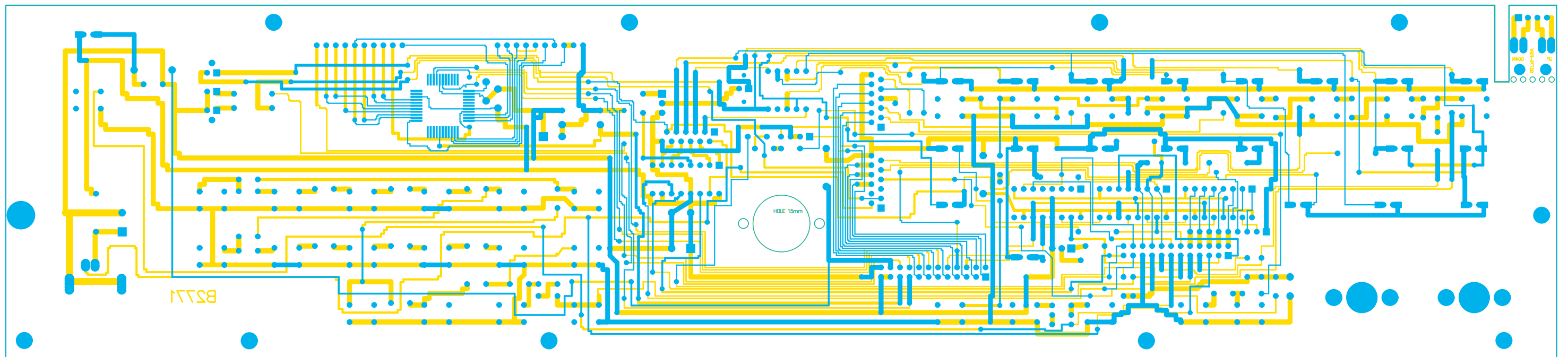

PCB Assembly

B2774 Top Side

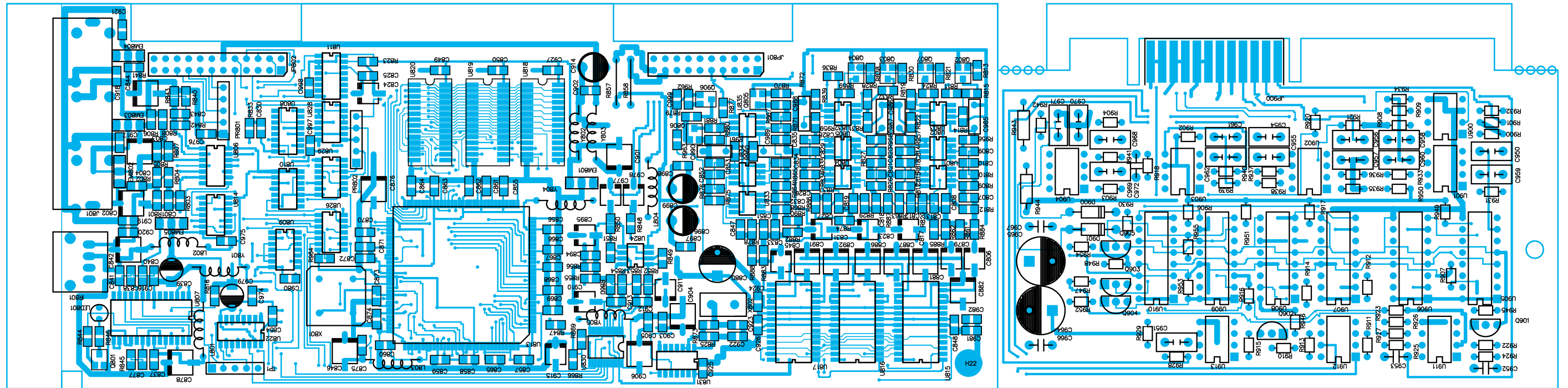

B2774 Patterns of Top and bottom

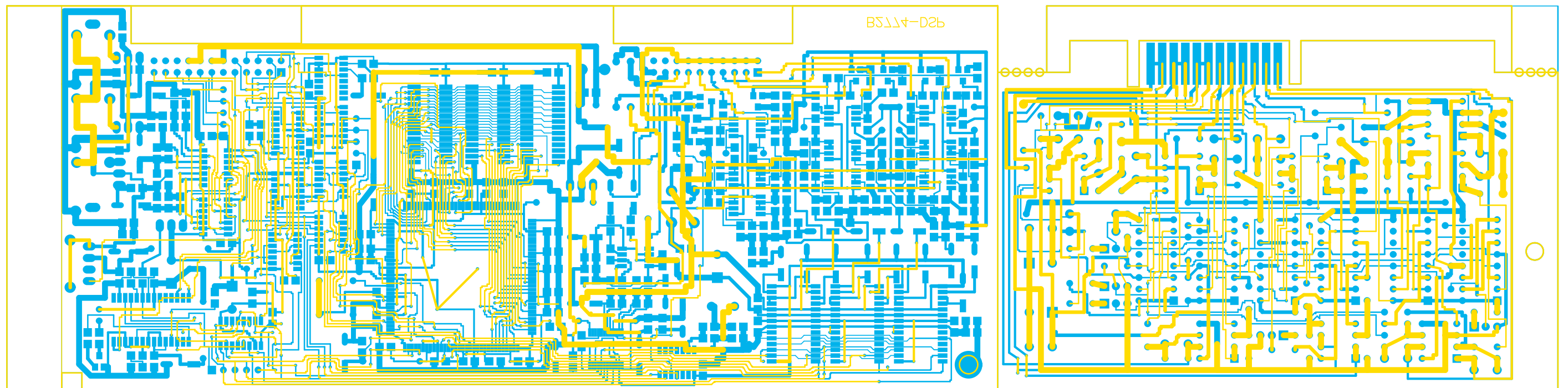

PCB Assembly

B2776 Top Side

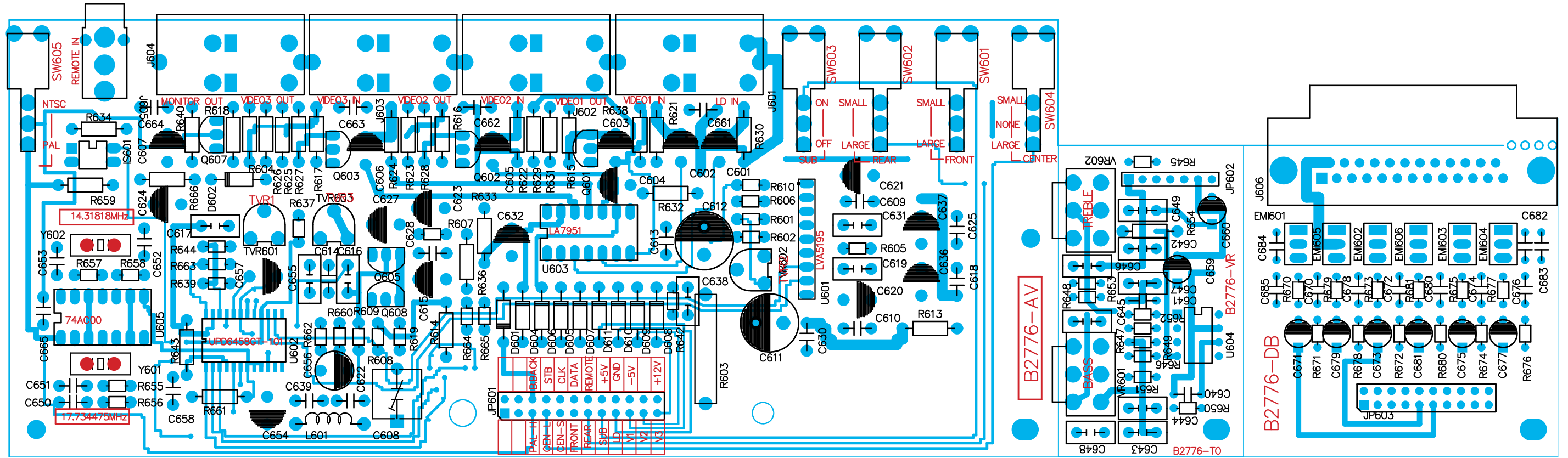

B2776 Patterns of To and Bottom

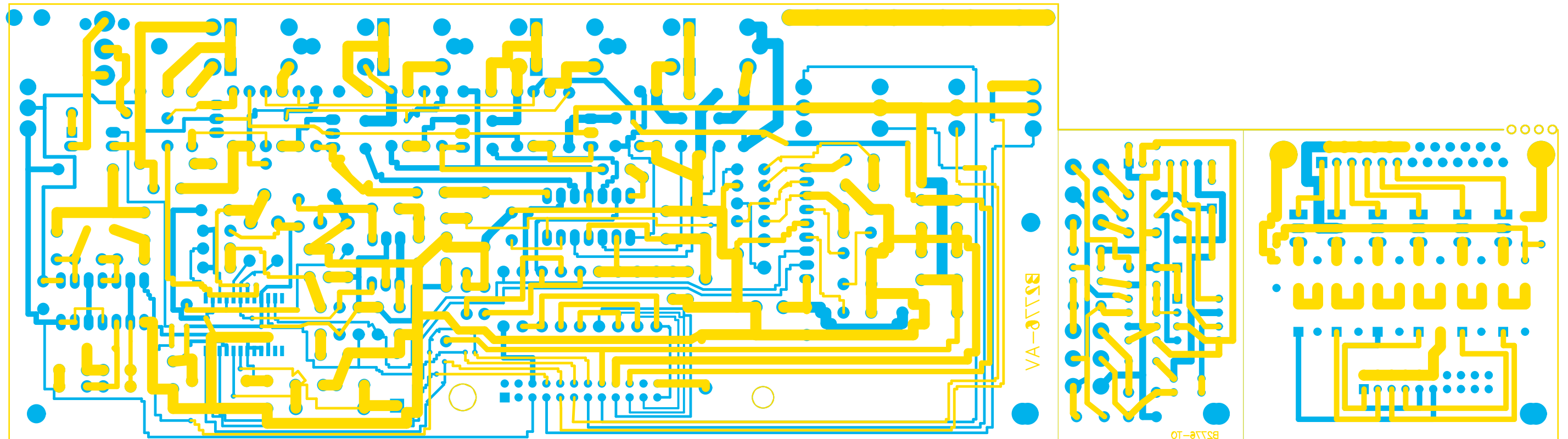

PCB Assembly

B2778 Top Side

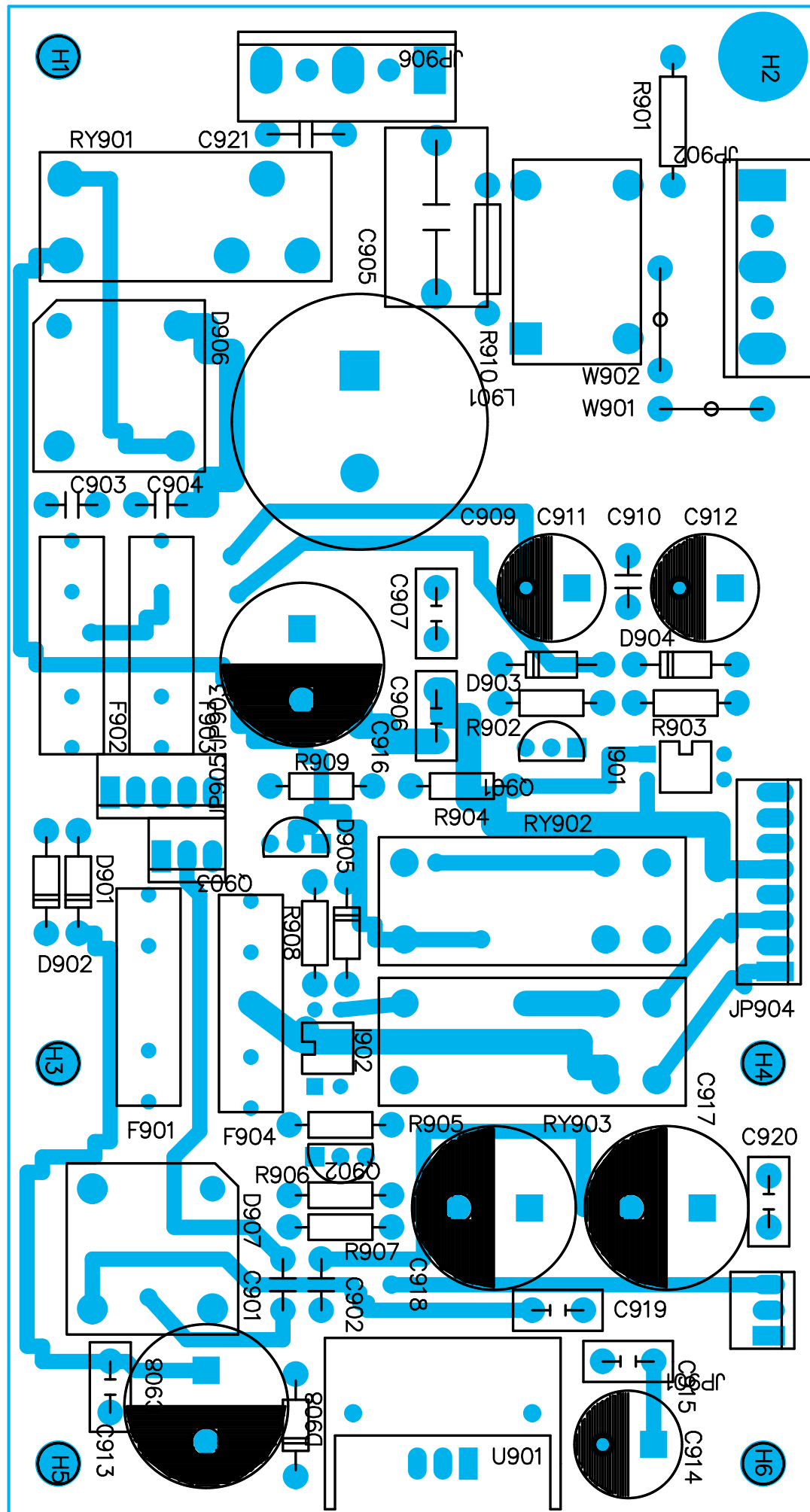

B2778 Patterns of Top and Bottom

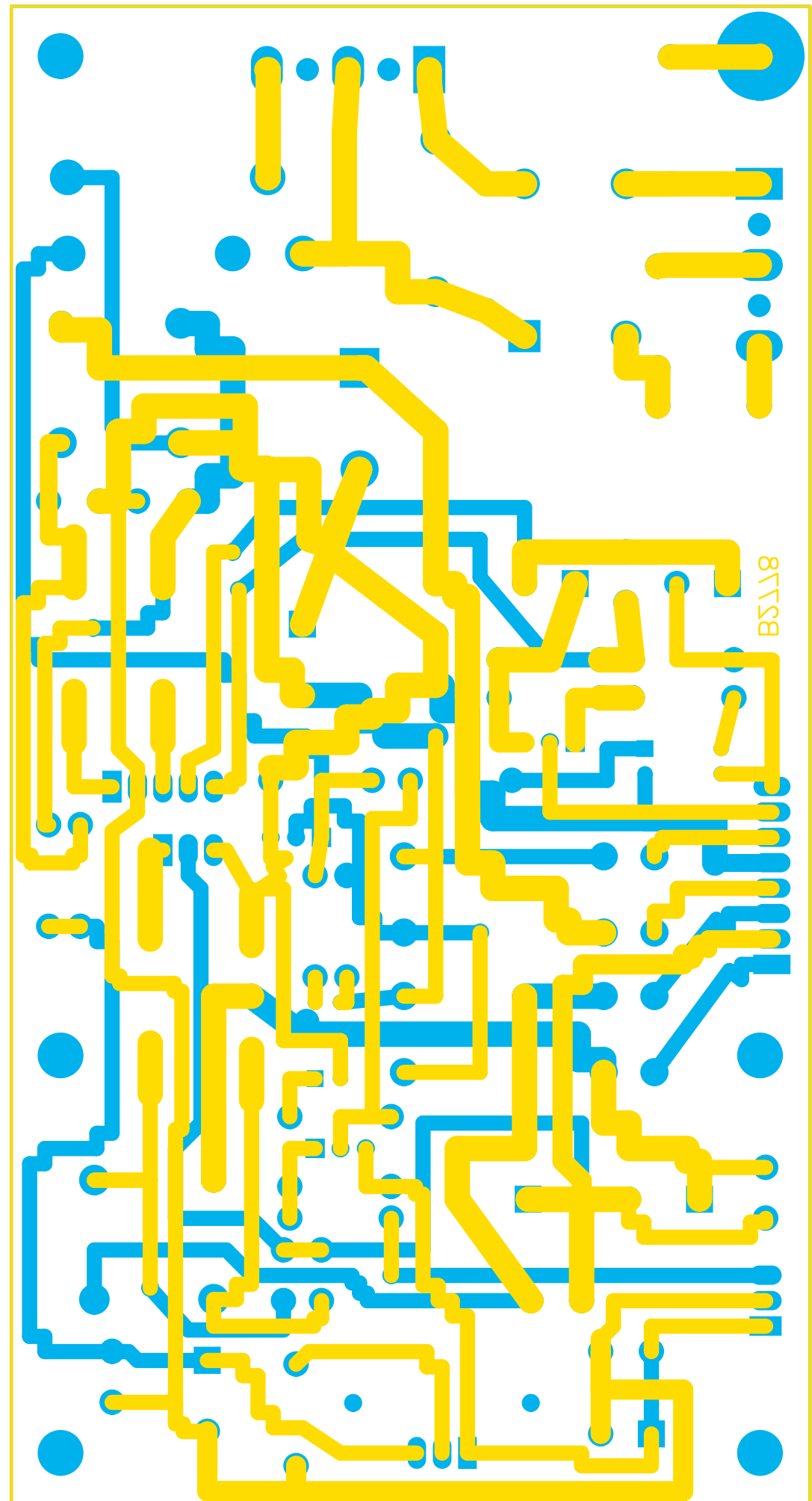

Schematic Diagram

Front

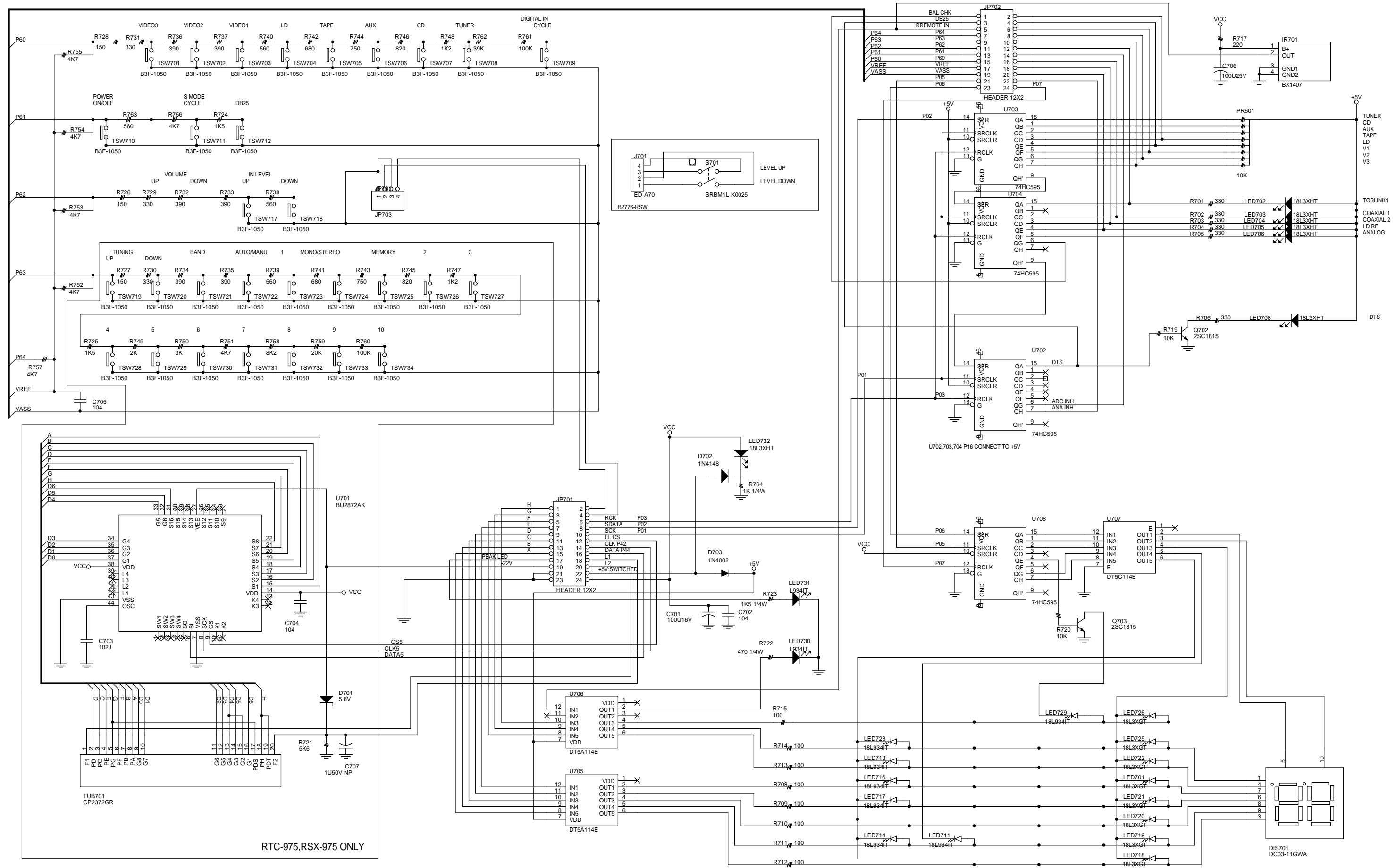

dB	mS	%	ZONE2 FUNC.	VIDEO4
AUDIO MUTE	LFE	ZONE2 MUTE	ZONE2 LEVEL	ZONE2 FUNC.
DIGITAL LOCK	S-MONO	4MS	30MS	SUB
7C3	DIALOG	3MS	20MS	S/L
PRO LOGIC	25%	3MS	15MS	S/R
3CH	50%	2MS	10MS	F/R
2CH	DYNA ON	1MS	5MS	CEN
75%	NONE	NONE	NONE	FIL
				TUNER

Schematic Diagram

Main

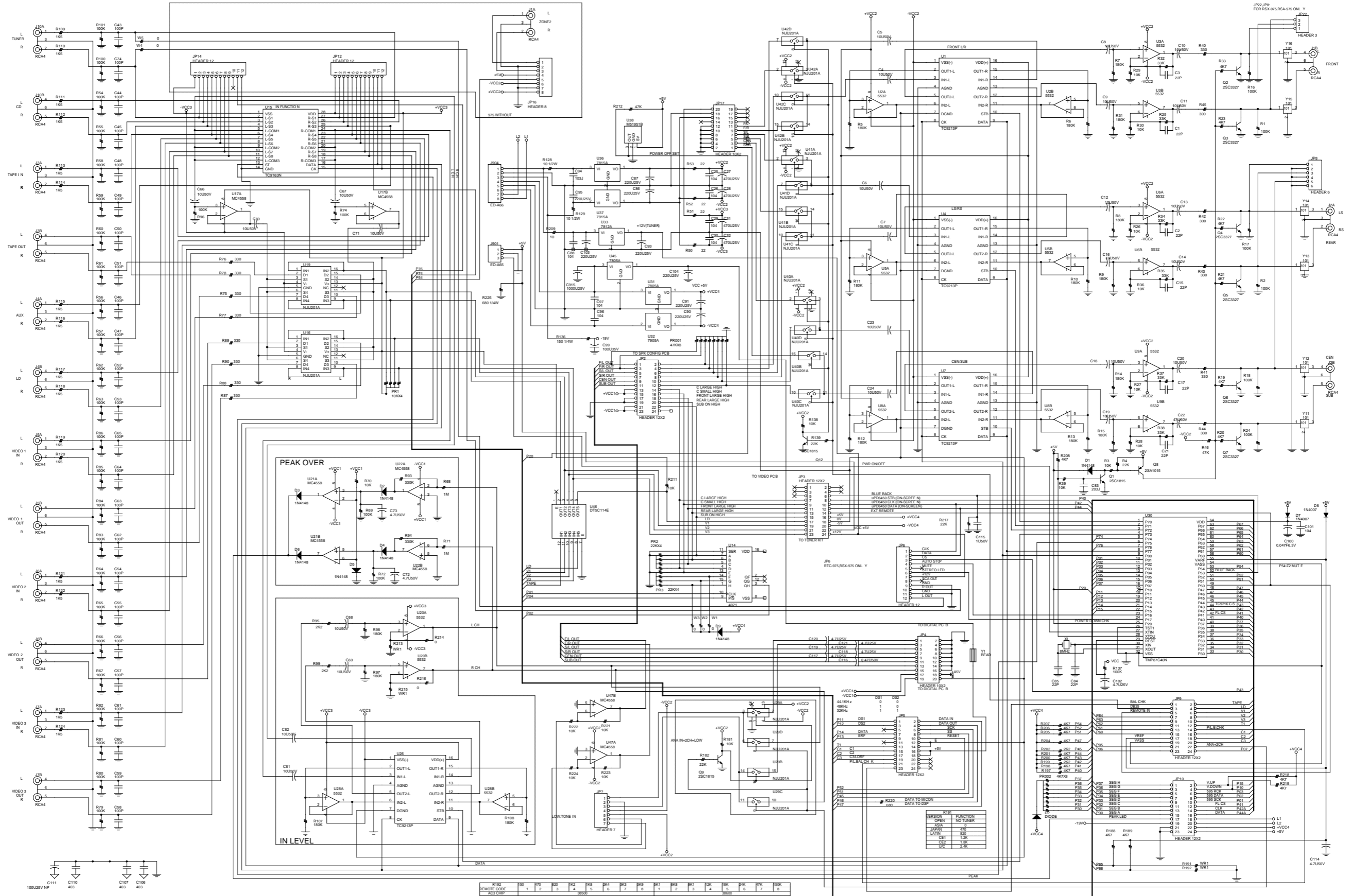

Schematic Diagram

Video

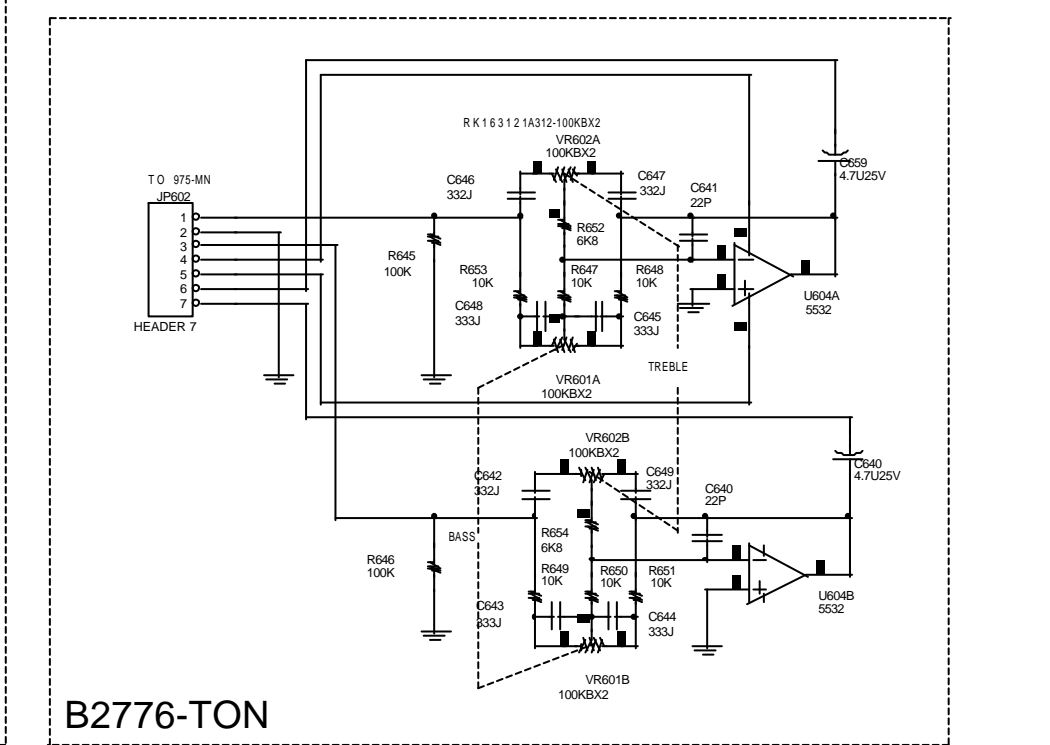
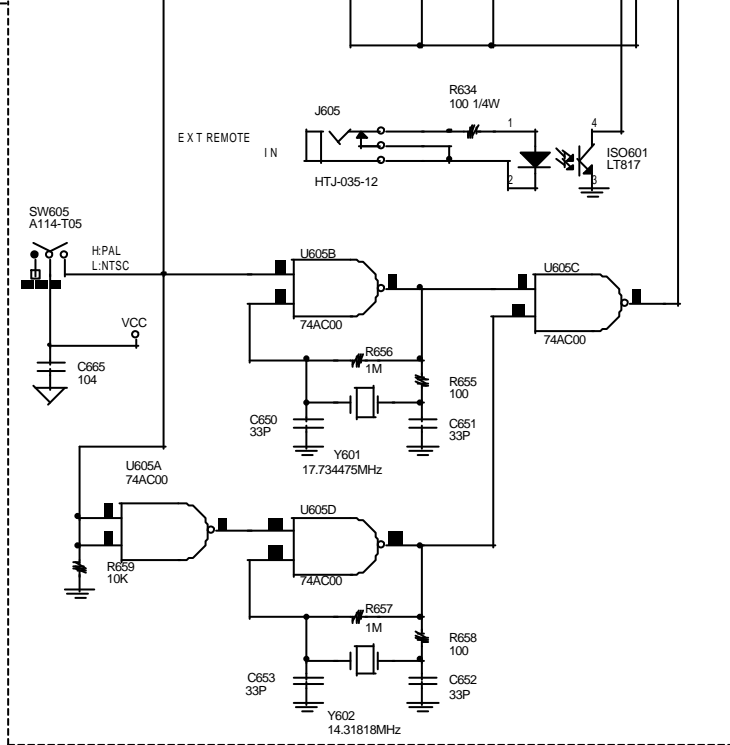
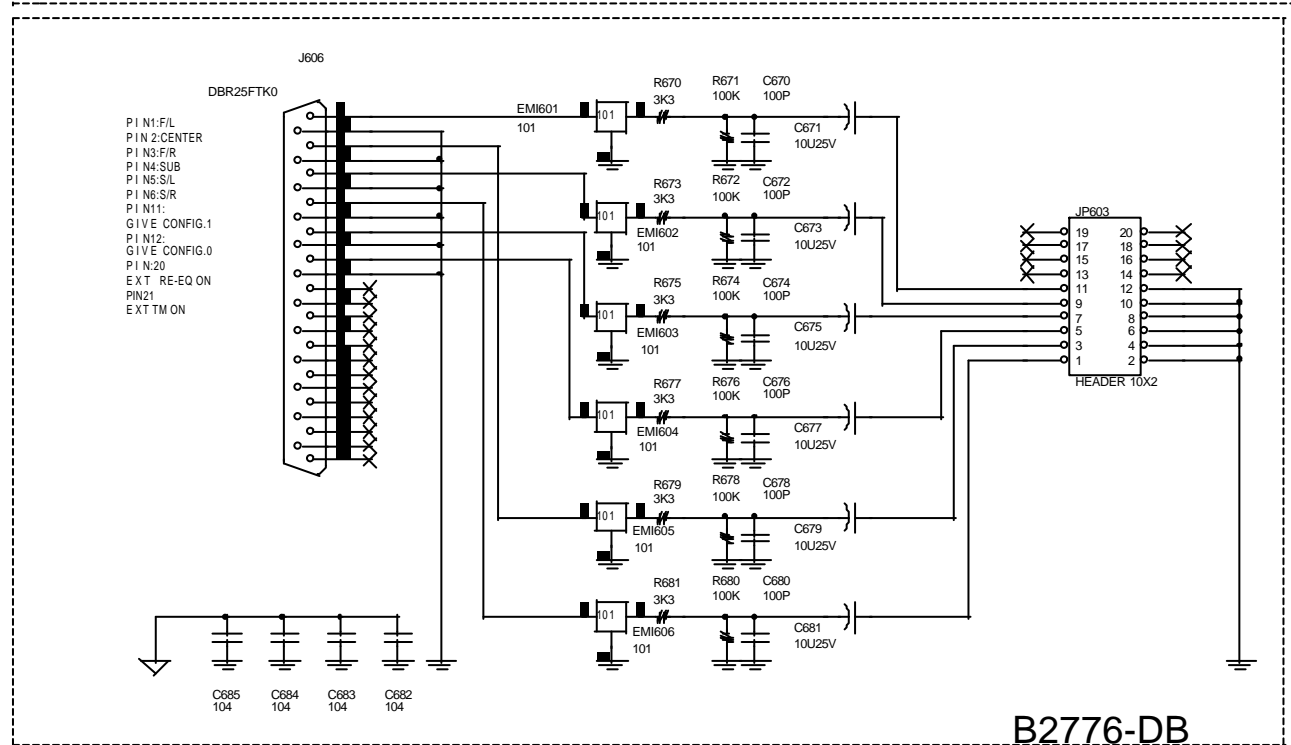
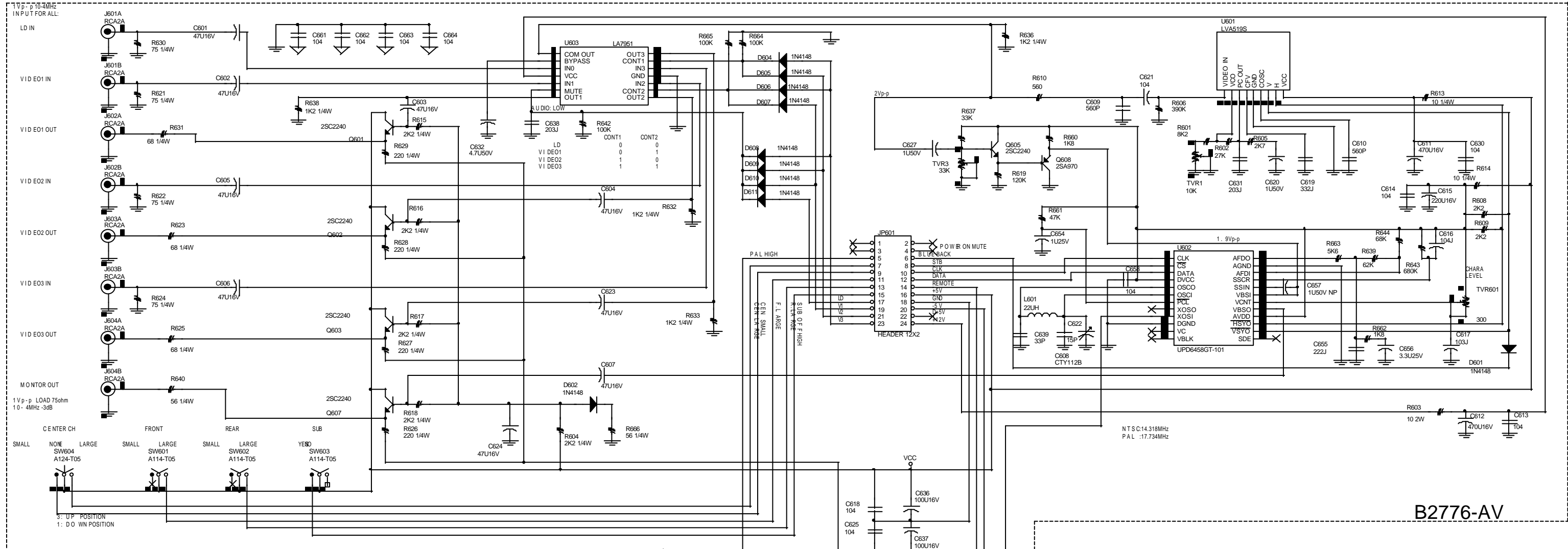

Schematic Diagram

Configuration

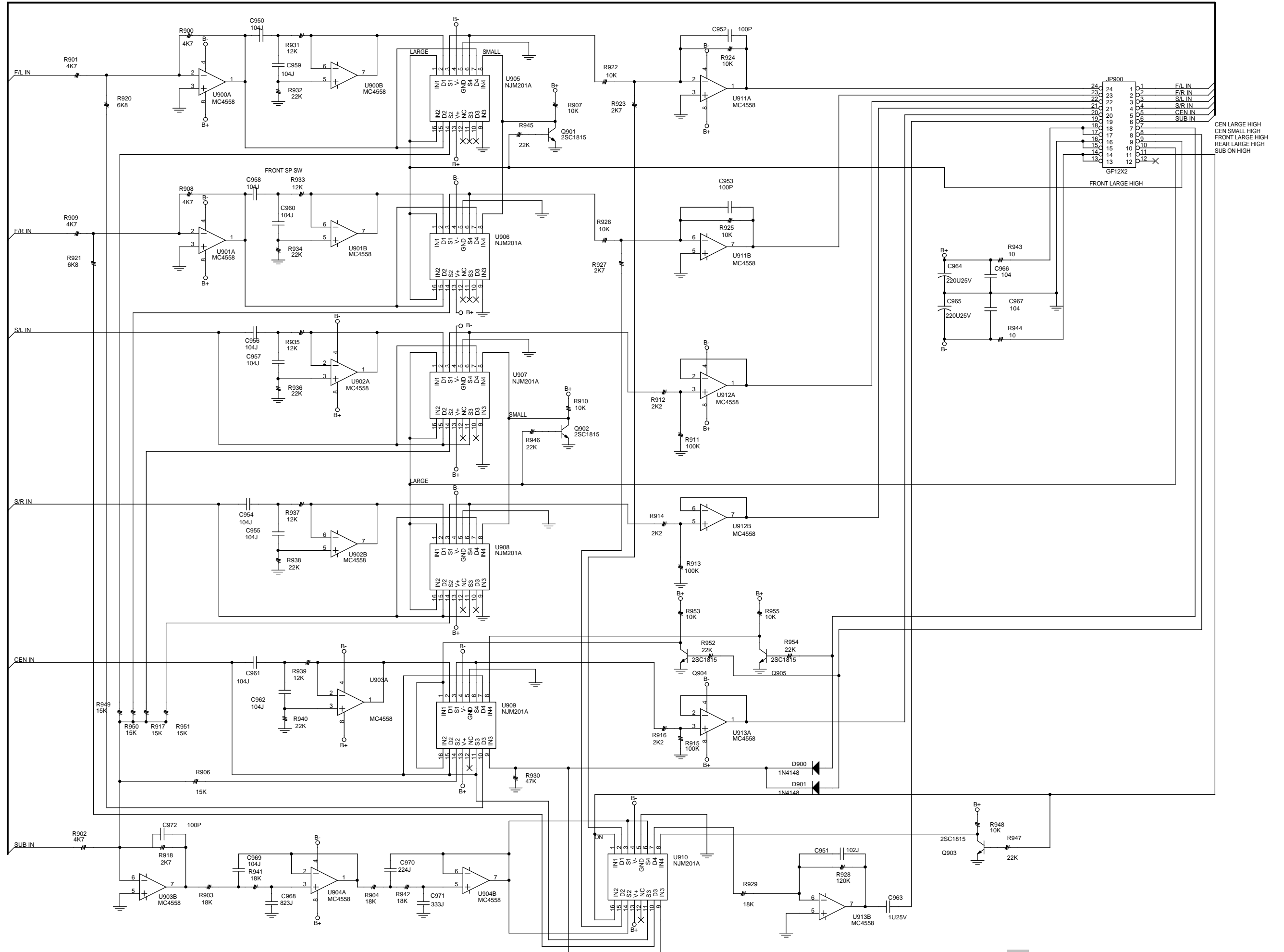

Schematic Diagram

DSP B2774

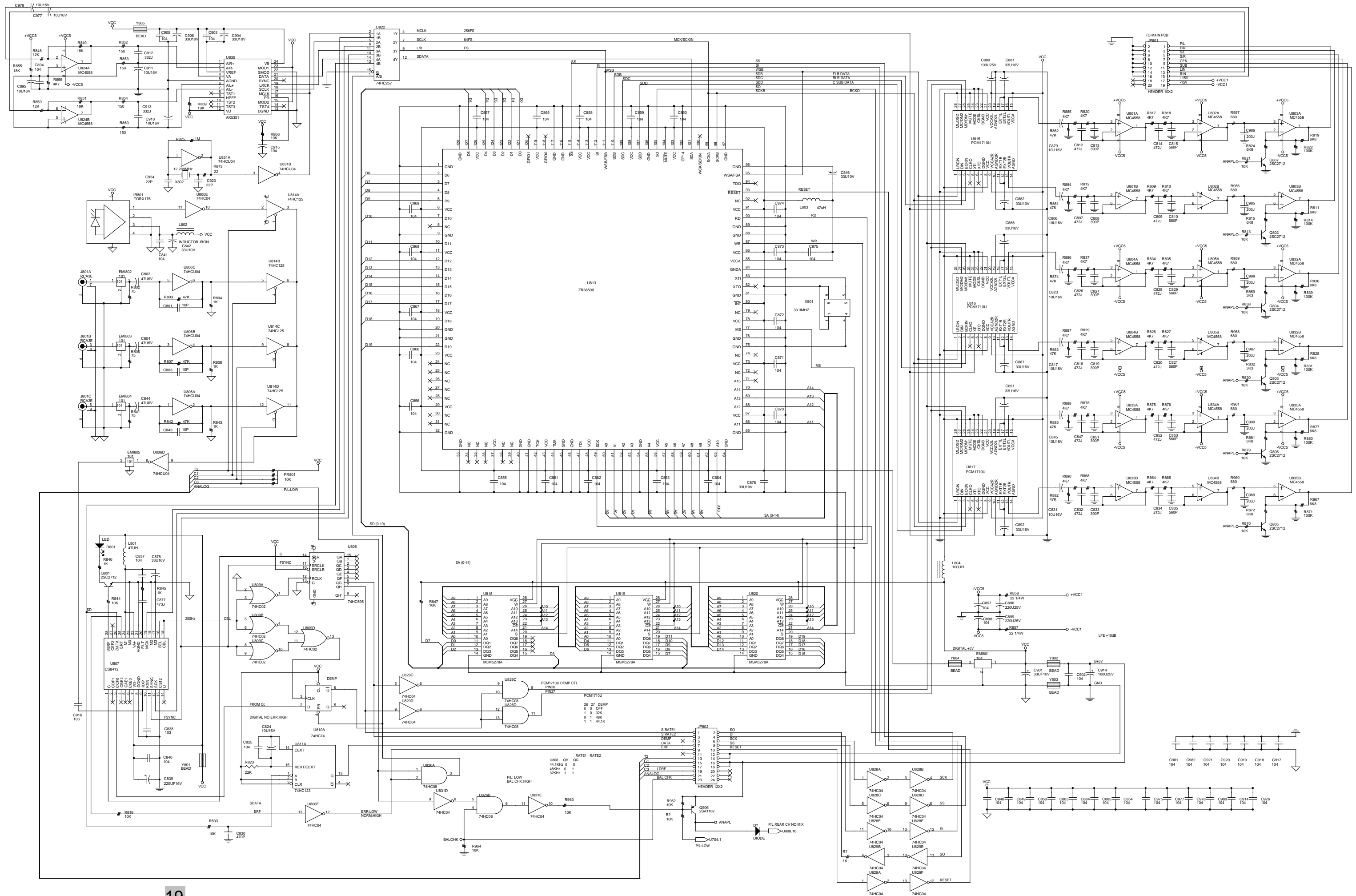

Schematic Diagram

Power Supply

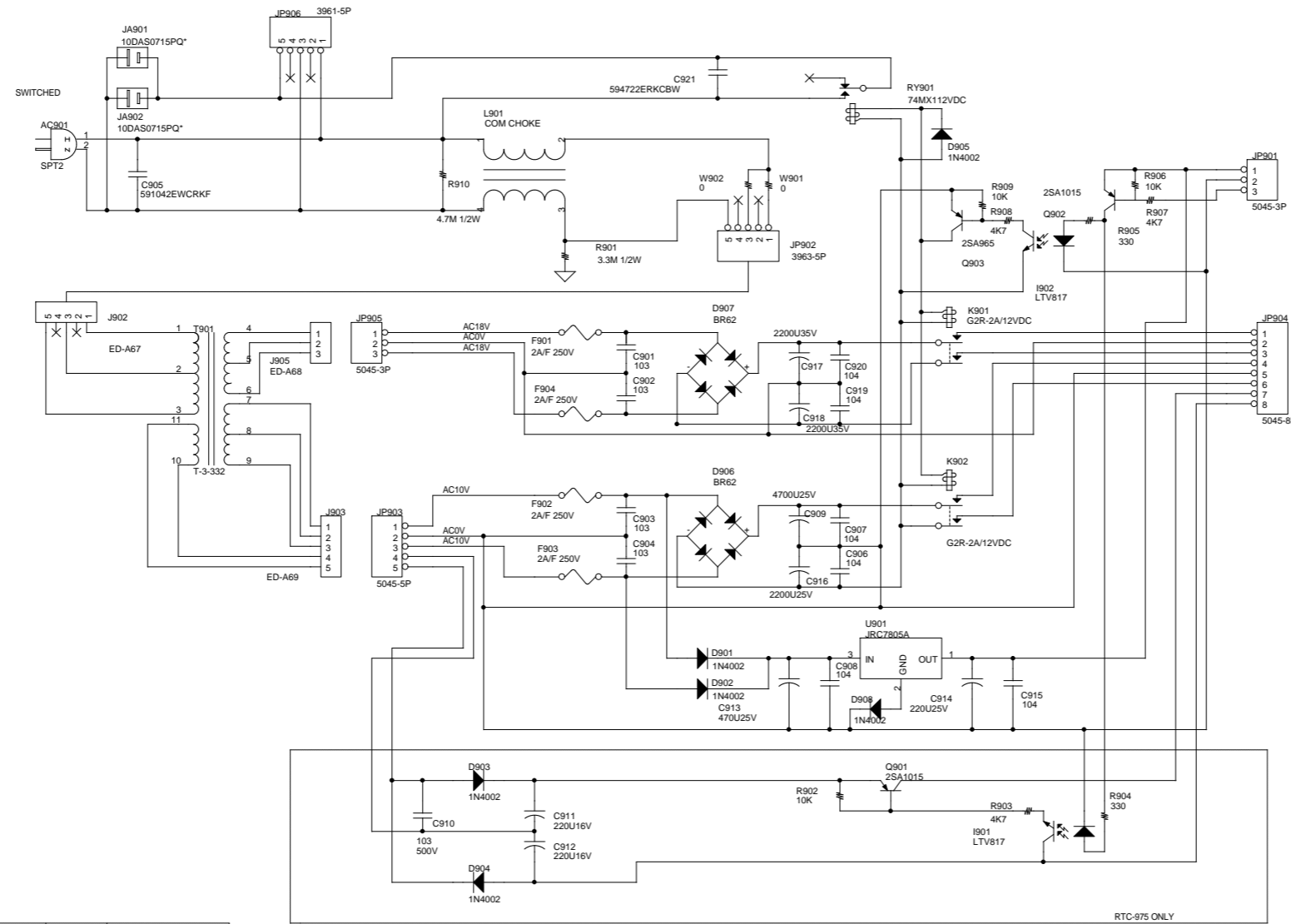

VERSION	WITH	WITHOUT
EURP TYPE:	C905 R910 L901	R901
USA.CND	R901	C905 R910 L901
USA.CND		

RTC-975 ONLY