

# ROTEL *hi-fi*

## RSP-980

Surround Sound Processor

# Technical Manual

### TABLE OF CONTENTS

Chassis Layout .....	1
Specifications .....	2
PC Board Ass'y Parts List.....	5
Printed Circuit Boards .....	15
Wiring Diagram .....	21
Functional Block Diagram.....	23
Schematic Diagram .....	25

### THE ROTEL CO.,LTD

4F,BUNZAN-SHINSEN-BLDG 10-10, SHINSEN-CHO, SHIBUYAKU TOKYO JAPAN

### ROTEL ELECTRONICS CO.,LTD

3F-2, NO.35, FU HSING NORTH ROAD, TAIPEI, TAIWAN, REPUBLIC OF CHINA

MN20002334

# Chassis Layout

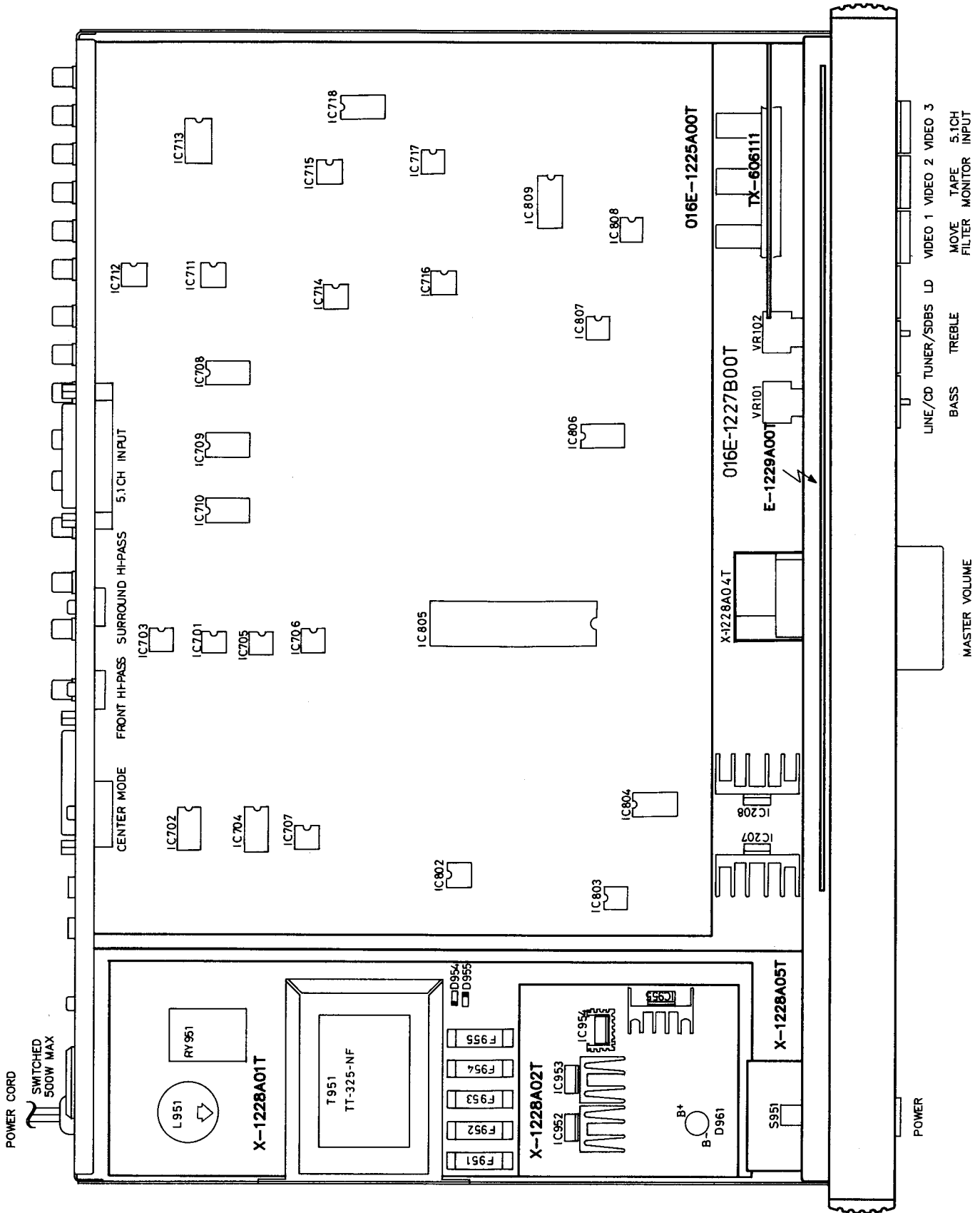

1 25V1BB-TF11 2KV1BB-TF1 1 1 1 6

# Specifications (Typical Values)

## 5.1 Ch Sensitivity (input 1 kHz 200 mV; Output 600 mV)

Sensitivity (Input 1 kHz; Output Max. 600 mV / 0 dB 150 mV; Auto Bal off) Center Mode: Wide.

	FRONT	CENTER	REAR
THX	200 mV	141.6 mV	141.6 mV
DOLBY	200 mV	141.6 mV	141.6 mV
MUSIC 1	250 mV	350 mV	141.6 mV
MUSIC 2	220 mV	240 mV	85 mV
MUSIC 3	250 mV	280 mV	440 mV
MUSIC 4	200 mV	280 mV	440 mV
STEREO	200 mV		
MONO	400 mV (Center Mode: Phantom)		

Delay Time - Rear Speaker (Dolby , THX) ..... 15 / 18 / 22 / 25 / 30 ms

Move Filter (Input 10kHz)-Front Speaker (Stereo) ..... - 6 dB

Frequency Response (Center Mode: Wide) Input 1kHz; Output 0 dB (150 mV).

	FRONT	CENTER	REAR
THX	20 Hz - 8 kHz, (-1 -0.2 dB)	20 Hz - 8 kHz, (-0.5 -3 dB)	
DOLBY	20 Hz - 40 kHz, (-2 -1 dB)	20 Hz - 40 kHz, (+0 -1 dB)	20 Hz- 6.5 kHz, (-1 -3 dB)
MUSIC 1	100Hz(-1dB),10kHz(-4.5dB)	100Hz - 10kHz, (-1 -1 dB)	
MUSIC 2	90Hz - 12kHz, (-1 -1dB)	100Hz - 20kHz, (-1 -5dB)	
MUSIC 3	35Hz - 40kHz, (-5 -1 dB)	100Hz - 40kHz, (-1 -1dB)	
MUSIC 4	100Hz(-2.5dB),10kHz(+2dB)	100Hz - 10kHz,(-2.5 +2dB)	
STEREO	20Hz - 40kHz, (+0 -1 dB)		
MONO	20Hz - 40kHz, (+0 -1dB)	30Hz - 30kHz, (-1 -1dB)	

Hum and Noise(Input Short, Dim Audio / IHF A)

	FRONT	CENTER	REAR
THX	78 / 80 dB	78 / 80 dB	72 / 75 dB
DOLBY	78 / 80 dB	78 / 80 dB	72 / 75 dB
MUSIC 1	80 / 82 dB	75 / 78 dB	72 / 75 dB
MUSIC 2	80 / 82 dB	75 / 78 dB	72 / 75 dB
MUSIC 3	80 / 82 dB	75 / 78 dB	70 / 72 dB
MUSIC 4	80 / 82 dB	75 / 78 dB	70 / 72 dB
STEREO	80 / 82 dB		
MONO	70 / 72 dB	75 / 78 dB	

Harmonic Distortion (Input 1kHz; Output 600 mV,80 kHz filter on)

	FRONT	CENTER	REAR
THX	0.03 %	0.04 %	0.03 %
DOLBY	0.03 %	0.04 %	0.03 %
MUSIC 1	0.03 %		
MUSIC 2	0.03 %		
MUSIC 3	0.03 %		
MUSIC 4	0.03 %		0.03 %
STEREO	0.03 %		
MONO	0.3 %		

Over Load (Input 1kHz; Output 1kHz 600 mV, Distortion 1%)

	FRONT	CENTER	REAR
THX	3.0V	>2.0V	1.5V
DOLBY	>3.0V		
MUSIC 1	>3.0V		
MUSIC 2	>3.0V		
MUSIC 3	>3.0V		
MUSIC 4	>3.0V		
STEREO	>3.0V		1.5V
MONO	>3.0V		

Residual Noise (Din Audio / IHF A)

FRONT	CENTER	REAR
5 / 4 uV	5 / 4 uV	5 / 4 uV

Channel Separation (Input 1kHz 200 mV) Output Master Volume Max.

	FRONT	CENTER	REAR
THX L or R	-35 dB	-40 dB	-50 dB
Center	-45 dB	-35 dB	-60 dB
Rear	-45 dB	-50 dB	
DOLBY L or R	-35 dB	-40 dB	-40 dB
Center	-35 dB	-35 dB	-60 dB
Rear	-40 dB	-40 dB	
MUSIC 1,2 L or R	-70 dB		
Rear			
MUSIC 3 L or R	-70 dB		
Rear			
MUSIC 4 L or R	-15 dB		
Rear			
STEREO L or R	-70 dB		

## SUB WOOFER

Sensitivity (Input 40 Hz; Output 600 mV) (Dolby , THX)

FRONT	CENTER	REAR
200mV	141.6mV	

Frequency Respose (Input Stereo, L Ch or R Ch) ..... 40 Hz - 80 Hz (0, -0.6 dB)

Hum and Noise (600 mV 0 dB, Din Audio / IHF A) ..... 70 / 75 dB

Hamonic Distortion (Input 40 Hz Stereo, L Ch or R Ch) ..... 0.3%

Residual (Volume min) (Din Audio /IHF A) ..... 5 uV / 4 uV

## BAL CHECK

TEST NOISE LEVELS  $\pm$  1 dB (150 mV = 0 dB)

OUTPUT CHANNEL	OUTPUT LEVEL
LEFT	47.45 mV , -10 dB
CENTER	47.45 mV , -10 dB
RIGHT	47.45 mV , -10 dB
SUBWOOFER	47.45 mV , -10 dB
SURROUND LEFT	67.02 mV , -7 dB
SURROUND RIGHT	67.02 mV , -7 dB

## BIAS ADJUSTMENT

input Video 1,2,3, Tuner / SDBS, TV Monitor Output Check.	
TV Monitor Switch C.S. Switch To C Point	Adjust VR401

## VIDEO

Frequency Response	3 Hz-10 MHz, -3 dB
Signal to Noise Ratio	70 dB
Input Impedance (D-Video, Composite)	75 ohms
Output Impedance (S-Video, Composite)	75 ohms
Output (S-Video, Composite)	1 volt, peak to peak, 75 ohms load
Power Consumption	46 watts
Power Requirements (AC)	120 volts 50/60 Hz or 230 volts 50/60 Hz
Weight	7.5 Kg, 16.5 Lb.
Dimensions	440 x 121 x 329 mm (W x H x D) 17-3/8" x 4-13/16" x 13" (W x H x D)

All specifications are accurate at the time of printing. Rotel reserves the right to make improvements with out notice.

# Parts List

NOTE: THE COMPONENTS INDENTIFIED BY  $\Delta$  MARK ARE FOR SAFFTY. REPLACE ONLY WITH ORIGINAL PARTS. DO NOT SUBSTITUTE.

SYMBOL	PARTS NO.	DESCRIPTION
<b>016E-1225A00T PCB ASSEMBLY</b>		
R701	RM52212811	R,METAL 22.1K 1/4W F
R702	RM53002812	R,METAL 30K 1/4W F
R703,704	RM51003813	R,METAL 100K 1/4W F
R705	RM54759815	R,METAL 47.5 1/4W F
R706	RM51001816	R,METAL 1K 1/4W F
R707	RM51003813	R,METAL 100K 1/4W F
R708	RM54759815	R,METAL 47.5 1/4W F
R709,710	RM51003813	R,METAL 100K 1/4W F
R711,712	RM54752810	R,METAL 47.5K 1/4W F
R713	RM52212811	R,METAL 22.1K 1/4W F
R714	RM53002812	R,METAL 30K 1/4W F
R715	RM54759815	R,METAL 47.5 1/4W F
R716	RM54752810	R,METAL 47.5K 1/4W F
R717	RM51001816	R,METAL 1K 1/4W F
R718	RM51003813	R,METAL 100K 1/4W F
R719	RM54759815	R,METAL 47.5 1/4W F
R720	RM52219817	R,METAL 22.1 1/4W F
R721	RM54753813	R,METAL 475K 1/4W F
R722,723	RM51002810	R,METAL 10K 1/4W F
R724	RM53322818	R,METAL 33.2K 1/4W F
R725	RM52219817	R,METAL 22.1 1/4W F
R726	RM51001816	R,METAL 1K 1/4W F
R727	RM52212811	R,METAL 22.1K 1/4W F
R728	RM53002812	R,METAL 30K 1/4W F
R729	RM54759815	R,METAL 47.5 1/4W F
R730	RM51001816	R,METAL 1K 1/4W F
R731	RM51003813	R,METAL 100K 1/4W F
R732	RM54759815	R,METAL 47.5 1/4W F
R733	RM51822812	R,METAL 18.2K 1/4W F
R734	RM59091818	R,METAL 9.09K 1/4W F
R735	RM51001816	R,METAL 1K 1/4W F
R736	RM54759815	R,METAL 47.5 1/4W F
R737	RM57322813	R,METAL 73K2 1/4W F
R738	RM54759815	R,METAL 47.5 1/4W F
R739	RM52211818	R,METAL 2.21K 1/4W F
R740,741	RM51822812	R,METAL 18.2K 1/4W F
R742	RM51502817	R,METAL 15K 1/4W F
R743	RM54759815	R,METAL 47.5 1/4W F
R745	RM59091818	R,METAL 9.09K 1/4W F
R746	RM51001816	R,METAL 1K 1/4W F
R747	RM54759815	R,METAL 47.5 1/4W F
R748,749	RM51003813	R,METAL 100K 1/4W F
R750-752	RM55622817	R,METAL 56.2K 1/4W F
R753	RM52211818	R,METAL 2.21K 1/4W F
R754	RM53322818	R,METAL 33K2 1/4W F
R755	RM52211818	R,METAL 2.21K 1/4W F
R756	RM53322818	R,METAL 33K2 1/4W F
R757	RM52211818	R,METAL 2.21K 1/4W F
R758	RM53322818	R,METAL 33K2 1/4W F
R759	RM52211818	R,METAL 2.21K 1/4W F
R760	RM53322818	R,METAL 33K2 1/4W F
R761	RM52211818	R,METAL 2.21K 1/4W F
R762	RM53322818	R,METAL 33K2 1/4W F
R764	RM52211818	R,METAL 2.21K 1/4W F
R765	RM53322818	R,METAL 33K2 1/4W F
R766	RM55622817	R,METAL 56.2K 1/4W F
R767,768	RM51003813	R,METAL 100K 1/4W F
R769	RM54751816	R,METAL 4.75K 1/4W F
R770,771	RM52219817	R,METAL 22.1 1/4W F
R772	RM51002810	R,METAL 10K 1/4W F
R773	RM54753813	R,METAL 475K 1/4W F
R774	RM51002810	R,METAL 10K 1/4W F
R775	RM52212811	R,METAL 22.1K 1/4W F
R776	RM53002812	R,METAL 30K 1/4W F
R777	RM54759815	R,METAL 47.5 1/4W F
R778	RM51003813	R,METAL 100K 1/4W F
R779	RM51001816	R,METAL 1K 1/4W F
R780	RM51003813	R,METAL 100K 1/4W F
R781	RM54759815	R,METAL 47.5 1/4W F
R782	RM51003813	R,METAL 100K 1/4W F
R783	RM52212811	R,METAL 22.1K 1/4W F

SYMBOL	PARTS NO.	DESCRIPTION
R784	RM53002812	R,METAL 30K 1/4W F
R785	RM51001816	R,METAL 1K 1/4W F
R786	RM51003813	R,METAL 100K 1/4W F
R787,788	RM54759815	R,METAL 47.5 1/4W F
R789,790	RM51003813	R,METAL 100K 1/4W F
R791,792	RM52219817	R,METAL 22.1 1/4W F
R793	RM51002810	R,METAL 10K 1/4W F
R794	RM54753813	R,METAL 475K 1/4W F
R795	RM51002810	R,METAL 10K 1/4W F
R796	RM51001816	R,METAL 1K 1/4W F
R797	RM53322818	R,METAL 33.2K 1/4W F
R798	RM51051819	R,METAL 1.05K 1/4W F
R799	RM54321810	R,METAL 4.32K 1/4W F
R800	RM58251814	R,METAL 8.25K 1/4W F
R801	RM54759815	R,METAL 47.5 1/4W F
R802	RM52742812	R,METAL 27.4K 1/4W F
R803	RM52101818	R,METAL 2.10K 1/4W F
R804	RM59090814	R,METAL 909 1/4W F
R805	RM54750812	R,METAL 475R 1/4W F
R806	RM52212811	R,METAL 22K1 1/4W F
R807	RM51002810	R,METAL 10K 1/4W F
R808	RM54759815	R,METAL 47.5 1/4W F
R809	RM52551812	R,METAL 2.55K 1/4W F
R810	RM52741819	R,METAL 2.74K 1/4W F
R811	RM55231816	R,METAL 5.23K 1/4W F
R812	RM54752810	R,METAL 47.5K 1/4W F
R813	RM56341812	R,METAL 6.34K 1/4W F
R814	RM51472813	R,METAL 14.7K 1/4W F
R815,816	RM54759815	R,METAL 47.5 1/4W F
R817	RM51002810	R,METAL 10K 1/4W F
R818	RM51051819	R,METAL 1.05K 1/4W F
R819	RM54321810	R,METAL 4.32K 1/4W F
R820	RM58251814	R,METAL 8.25K 1/4W F
R821	RM54759815	R,METAL 47.5 1/4W F
R822	RM52101818	R,METAL 2.10K 1/4W F
R823	RM52742812	R,METAL 27.4K 1/4W F
R824	RM54750812	R,METAL 475R 1/4W F
R825	RM54752810	R,METAL 47.5K 1/4W F
R826	RM59090814	R,METAL 909 1/4W F
R827	RM51002810	R,METAL 10K 1/4W F
R828	RM54759815	R,METAL 47.5 1/4W F
R829	RM52551812	R,METAL 2.55K 1/4W F
R830	RM52741819	R,METAL 2.74K 1/4W F
R831	RM55231816	R,METAL 5.23K 1/4W F
R832	RM51002810	R,METAL 10K 1/4W F
R833	RM54752810	R,METAL 47.5K 1/4W F
R834	RM51472813	R,METAL 14.7K 1/4W F
R835	RM56341812	R,METAL 6.34K 1/4W F
R836,837	RM54759815	R,METAL 47.5 1/4W F
R838,839	RM52219817	R,METAL 22.1 1/4W F
R840	RM51002810	R,METAL 10K 1/4W F
R841	RM54753813	R,METAL 475K 1/4W F
R842	RM51002810	R,METAL 10K 1/4W F
R843,844	RM54752810	R,METAL 47.5K 1/4W F
R846	RM54752810	R,METAL 47.5K 1/4W F
R848	RM51001816	R,METAL 1K 1/4W F
R850	RM51001816	R,METAL 1K 1/4W F
R851	RM54752810	R,METAL 47K5 1/4W F
R852	RM51005810	R,METAL 10M 1/4W F
R853	RM54759815	R,METAL 47.5 1/4W F
R854,855	RM56341812	R,METAL 6.34K 1/4W F
R856	RM54759815	R,METAL 47.5 1/4W F
R857	RM56341812	R,METAL 6.34K 1/4W F
R858	RM52002816	R,METAL 20K 1/4W F
R859	RM52212811	R,METAL 22.1K 1/4W F
R860	RM51003813	R,METAL 100K 1/4W F
R861,862	RM51472813	R,METAL 14.7K 1/4W F
R863	RM52002816	R,METAL 20K 1/4W F
R864	RM52212811	R,METAL 22.1K 1/4W F
R865	RM54759815	R,METAL 47.5 1/4W F
R866	RM51472813	R,METAL 14.7K 1/4W F
R867	RM54759815	R,METAL 47.5 1/4W F
R868	RM51001816	R,METAL 1K 1/4W F

# Parts List

SYMBOL	PARTS NO.	DESCRIPTION
R869	RM53922810	R,METAL 39.2K 1/4W F
R870	RM52219817	R,METAL 22.1 1/4W F
R871	RM51501813	R,METAL 1.5K 1/4W F
R872	RM51001816	R,METAL 1K 1/4W F
R873	RM51501813	R,METAL 1.5K 1/4W F
R874	RM51001816	R,METAL 1K 1/4W F
R875	RM52219817	R,METAL 22.1 1/4W F
R876	RM51002810	R,METAL 10K 1/4W F
R877	RM54753813	R,METAL 475K 1/4W F
R878	RM51002810	R,METAL 10K 1/4W F
R879	RM51003813	R,METAL 100K 1/4W F
R880	RM51002810	R,METAL 10K 1/4W F
R881	RM54753813	R,METAL 475K 1/4W F
R893	RM54751816	R,METAL 4.75K 1/4W F
R896,897	RM51003813	R,METAL 100K 1/4W F
R898	RM51502817	R,METAL 15K 1/4W F
R899	RM54752810	R,METAL 47.5K 1/4W F
R900	RM57501811	R,METAL 7.5K 1/4W F
R901	RM54752810	R,METAL 47.5K 1/4W F
R902	RM51502817	R,METAL 15K 1/4W F
R903	RM57501811	R,METAL 7.5K 1/4W F
R904-907	RM51003813	R,METAL 100K 1/4W F
R908	RM54751816	R,METAL 4.75K 1/4W F
R909,910	RM52219817	R,METAL 22.1 1/4W F
R911	RM54753813	R,METAL 475K 1/4W F
R912,913	RM51002810	R,METAL 10K 1/4W F
R914	RM55620810	R,METAL 562 1/4W F
R915	RM54752810	R,METAL 47.5K 1/4W F
R916	RM54751816	R,METAL 4.75K 1/4W F
R917	RM54759815	R,METAL 47.5 1/4W F
R918	RM51820815	R,METAL 182 1/4W F
R919	RM55621813	R,METAL 5.62K 1/4W F
R920	RM51502817	R,METAL 15K 1/4W F
R921	RM54750812	R,METAL 475 1/4W F
R922	RM53322818	R,METAL 33.2K 1/4W F
R923	RM54759815	R,METAL 47.5 1/4W F
R924	RM51002810	R,METAL 10K 1/4W F
R925	RM56812810	R,METAL 68.1K 1/4W F
R926	RM51212815	R,METAL 12K1 1/4W F
R927	RM56812810	R,METAL 68.1K 1/4W F
R928,929	RM54759815	R,METAL 47.5 1/4W F
R930	RM54752810	R,METAL 47.5K 1/4W F
R931	RM56812810	R,METAL 68.1K 1/4W F
R932	RM51212815	R,METAL 12.1K 1/4W F
R934	RM53321814	R,METAL 3.32K 1/4W F
R935	RM51543819	R,METAL 154K 1/4W F
R936	RM52743816	R,METAL 274K 1/4W F
R937	RM51003813	R,METAL 100K 1/4W F
R938	RM55111811	R,METAL 5.11K 1/4W F
R941	RM52219817	R,METAL 22.1 1/4W F
R942	RM51003813	R,METAL 100K 1/4W F
R947	RM53322818	R,METAL 33K2 1/4W F
R945,946	RM54751816	R,METAL 4.75K 1/4W F
C701,702	CY21008428	CAP,LAYER 50V 0.1uF
C703,704	CE41005257	CAP,ELEC. 25V 100uF
C705,706	CY21008428	CAP,LAYER 50V 0.1uF
C707,708	CE41005257	CAP,ELEC. 25V 100uF
C709,710	CY21008428	CAP,LAYER 50V 0.1uF
C711-714	CE41005257	CAP,ELEC. 25V 100uF
C715	CY21008428	CAP,LAYER 50V 0.1uF
C716	CE41005257	CAP,ELEC. 25V 100uF
C717,718	CY21008428	CAP,LAYER 50V 0.1uF
C719-722	CE41005257	CAP,ELEC. 25V 100uF
C723,724	CY21008428	CAP,LAYER 50V 0.1uF
C725	CE41005257	CAP,ELEC. 25V 100uF
C726-730	CS41011422	CAP,STYROL 50V 100P
C732	CS41011422	CAP,STYROL 50V 100P
C733,734	CY21008428	CAP,LAYER 50V 0.1uF
C735	CE41005257	CAP,ELEC. 25V 100uF
C736,737	CY21008428	CAP,LAYER 50V 0.1uF
C738,739	CE41005257	CAP,ELEC. 25V 100uF
C740,741	CY21008428	CAP,LAYER 50V 0.1uF
C742-746	CE41005257	CAP,ELEC. 25V 100uF

SYMBOL	PARTS NO.	DESCRIPTION
C747,748	CM13310427	CAP,MYLAR 50V 332 J
C749	CE41005257	CAP,ELEC. 25V 100uF
C750,751	CM11009426	CAP,MYLAR 50V 103 J
C752,753	CM14710425	CAP,MYLAR 50V 472 J
C754-756	CE41005257	CAP,ELEC. 25V 100uF
C759	CE41005257	CAP,ELEC. 25V 100uF
C760,761	CM14710425	CAP,MYLAR 50V 472 J
C762,763	CM11009426	CAP,MYLAR 50V 103 J
C764-767	CE41005257	CAP,ELEC. 25V 100uF
C795	CE44705849	CAP,ELEC. 10V 470uF
C796,797	CE41005257	CAP,ELEC. 25V 100uF
C798	CE44705849	CAP,ELEC. 10V 470uF
C790,800	CY21008428	CAP,LAYER 50V 0.1uF
C801	CM12208420	CAP,MYLAR 50V 224 J
C803,804	CM15610426	CAP,MYLAR 50V 562 J
C805	CM14709423	CAP,MYLAR 50V 473 J
C806	CE41005257	CAP,ELEC. 25V 100uF
C807	CM15610426	CAP,MYLAR 50V 562 J
C808	CE41005257	CAP,ELEC. 25V 100uF
C809	CM14709423	CAP,MYLAR 50V 473 J
C810	CE41005257	CAP,ELEC. 25V 100uF
C811	CM14709423	CAP,MYLAR 50V 473 J
C812	CE41005257	CAP,ELEC. 25V 100uF
C813	CE41006250	CAP,ELEC. 25V 10uF
C814	CE41005257	CAP,ELEC. 25V 100uF
C815	CE41005257	CAP,ELEC. 25V 100uF
C816	CE41006250	CAP,ELEC. 25V 10uF
C817	CE44707251	CAP,ELEC. 25V 4.7uF
C818,819	CY22208425	CAP,LAYER 50V 0.22uF
C820	CE41006500	CAP,ELEC. 50V 10uF
C821	CE41005257	CAP,ELEC. 25V 100uF
C822	CY21008428	CAP,LAYER 50V 0.1uF
C824	CE44707251	CAP,ELEC. 25V 4.7uF
C825,826	CY22208425	CAP,LAYER 50V 0.22uF
C827	CY23308427	CAP,LAYER 50V 0.33uF
C828,829	CY21008428	CAP,LAYER 50V 0.1uF
C830-832	CY23308427	CAP,LAYER 50V 0.33uF
C833	CS46811428	CAP,STYROL 50V 680P
C834	CM12209423	CAP,MYLAR 50V 223 J
C835,836	CY21008428	CAP,LAYER 50V 0.1uF
C837	CM12209423	CAP,MYLAR 50V 223 J
C838	CS46811428	CAP,STYROL 50V 680P
C839,840	CM12209423	CAP,MYLAR 50V 223 J
C841	CY21008428	CAP,LAYER 50V 0.1uF
C842-844	CE41005257	CAP,ELEC. 25V 100uF
C845	CM11010428	CAP,MYLAR 50V 102 J
C846	CS45811420	CAP,STYROL 50V 560P
C847	CS41511420	CAP,STYROL 50V 150P
C848	CE41005257	CAP,ELEC. 25V 100uF
C851	CE41007503	CAP,ELEC. 50V 1uF
C852	CE41005257	CAP,ELEC. 25V 100uF
C853	CS45811420	CAP,STYROL 50V 560P
C854	CE41005257	CAP,ELEC. 25V 100uF
C855	CM18210423	CAP,MYLAR 50V 822 J
C856	CM12709420	CAP,MYLAR 50V 273 J
C857	CM14710425	CAP,MYLAR 50V 472 J
C858-860	CE41006250	CAP,ELEC. 25V 10uF
C861	CM14709423	CAP,MYLAR 50V 473 J
C862	CE41006250	CAP,ELEC. 25V 10uF
C863	CY21008428	CAP,LAYER 50V 0.1uF
C864	CY23308427	CAP,LAYER 50V 0.33uF
C865	CE41005257	CAP,ELEC. 25V 100uF
C866	CY21008428	CAP,LAYER 50V 0.1uF
C867	CE41005257	CAP,ELEC. 25V 100uF
C871,872	CY22208425	CAP,LAYER 50V 0.22uF
C881,882	CM12208420	CAP,MYLAR 50V 224 J
Q701	TR11000015	TRANSISTOR 2SA608KF
Q702	TR11000064	TRANSISTOR 2SA1345-AC
Q703	TR31000034	TRANSISTOR 2SC536G-NP-AA
Q704	TR11000015	TRANSISTOR 2SA608KF
Q705	TR11000064	TRANSISTOR 2SA1345-AC
Q706	TR31000101	TRANSISTOR 2SC3399-AC

# Parts List

NOTE: THE COMPONENTS IDENTIFIED BY  $\Delta$  MARK ARE FOR SAFFTY. REPLACE ONLY WITH ORIGINAL PARTS. DO NOT SUBSTITUTE.

SYMBOL	PARTS NO.	DESCRIPTION
Q707	TR11000015	TRANSISTOR 2SA608KF
Q708	TR11000064	TRANSISTOR 2SA1345-AC
Q709	TR31000034	TRANSISTOR 2SC536G-NP-AA
Q710	TR11000015	TRANSISTOR 2SA608KF
Q711	TR11000064	TRANSISTOR 2SA1345-AC
Q717	TR31000101	TRANSISTOR 2SC3399-AC
Q801	TR10000047	TRANSISTOR 2SB631KF
Q802	TR40000150	TRANSISTOR 2SD600K
Q803	TR11000015	TRANSISTOR 2SA608KF
Q804	TR11000064	TRANSISTOR 2SA1345-AC
Q805	TR31000034	TRANSISTOR 2SC536G-NP-AA
Q808	TR31000101	TRANSISTOR 2SC3399-AC
Q809	TR11000064	TRANSISTOR 2SA1345-AC
Q810	TR11000015	TRANSISTOR 2SA608KF
D801,802	DD80000021	DIODE IN4148-86
IC701	IC00002296	IC NJM5532DD
IC702	IC00001772	IC LC4966
IC703	IC00002296	IC NJM5532DD
IC704	IC00001772	IC LC4966
IC705-707	IC00002296	IC NJM5532DD
IC708-710	IC00001772	IC LC4966
IC711,712	IC00001292	IC NJM2041DD
IC713	IC00001772	IC LC4966
IC714-717	IC00001292	IC NJM2041DD
IC718	IC00001772	IC LC4966
IC802,803	IC00000019	IC LA6458D
IC804	IC00001772	IC LC4966
IC805	IC00002661	IC SSM2128A-014P
IC806	IC00001772	IC LC4966
IC807,808	IC 00001292	IC NJM2041DD
IC809	IC00003811	IC TA7629P
DP701	SA00003252	D-SUB CONNEX.W/CYLINDERX2 DBL25SBTK2NS FEMALE
S701,702	SH20000538	SLIDE SW 4TR-3179
S703	SH20000393	SLIDE SW 4TR-2976
<b>016E-1226A00T PCB ASSEMBLY</b>		
R401-405	RM57509810	R,METAL 75R 1/4W F
R406	RM51211811	R,METAL 1.21K 1/4W F
R407	RM51009815	R,METAL 10 1/4W F
R408	RM51211811	R,METAL 1.21K 1/4W F
R409	RM52749818	R,METAL 27.4 1/4W F
R410-419	RM57509810	R,METAL 75R 1/4W F
R420	RM51211811	R,METAL 1.21K 1/4W F
R421	RM51009815	R,METAL 10 1/4W F
R422	RM51211811	R,METAL 1.21K 1/4W F
R423	RM51009815	R,METAL 10 1/4W F
R424	RM51211811	R,METAL 1.21K 1/4W F
R425	RM51009815	R,METAL 10 1/4W F
R426	RM51211811	R,METAL 1.21K 1/4W F
R427	RM51009815	R,METAL 10 1/4W F
R428-431	RM51004817	R,METAL 1M 1/4W F
R432-442	RM55629812	R,METAL 56.2 1/4W F
R443,444	RM53320810	R,METAL 332 1/4W F
R445	RM51000812	R,METAL 100 1/4W F
R446	RM51502817	R,METAL 15K 1/4W F
R447	RM52740815	R,METAL 274 1/4W F
R448	RM57509810	R,METAL 75R 1/4W F
R449	RM51502817	R,METAL 15K 1/4W F
R450	RM54759815	R,METAL 47.5 1/4W F
R451	RM52211818	R,METAL 2.21K 1/4W F
R452	RM52219817	R,METAL 22.1 1/4W F
R453	RM52740815	R,METAL 274 1/4W F
R454	RM52219817	R,METAL 22.1 1/4W F
R455	RM55628819	R,METAL 5.62 1/4W F
R456	RM51002810	R,METAL 10K 1/4W F
E457	RM52219817	R,METAL 22.1 1/4W F
R458	RM55628819	R,METAL 5.62 1/4W F
R459	RM51002810	R,METAL 10K 1/4W F
R460	RM51000812	R,METAL 100 1/4W F
R461	RM53920813	R,METAL 392 1/4W F
R465	RM52219817	R,METAL 22.1 1/4W F

SYMBOL	PARTS NO.	DESCRIPTION
R466	RM55628819	R,METAL 5.62 1/4W F
R467	RM53920813	R,METAL 392 1/4W F
R468	RM51002810	R,METAL 10K 1/4W F
R469	RM52219817	R,METAL 22.1 1/4W F
R470	RM55628819	R,METAL 5.62 1/4W F
R471	RM52219817	R,METAL 22.1 1/4W F
R472	RM51502817	R,METAL 15K 1/4W F
R473	RM53320810	R,METAL 332 1/4W F
R474	RM52219817	R,METAL 22.1 1/4W F
R475	RM52740815	R,METAL 274 1/4W F
R476	RM52211818	R,METAL 2.21K 1/4W F
R477	RM51002810	R,METAL 10K 1/4W F
R478	RM55628819	R,METAL 5.62 1/4W F
R480	RM52219817	R,METAL 22.1 1/4W F
R481	RM54750812	R,METAL 475 1/4W F
R482	RM51001816	R,METAL 1K 1/4W F
R483	RM52210814	R,METAL 221 1/4W F
R484	RM53320810	R,METAL 332 1/4W F
R485	RM51000812	R,METAL 100 1/4W F
R486	RM55620810	R,METAL 562 1/4W F
R487	RM51004817	R,METAL 1M 1/4W F
R488	RM58251814	R,METAL 8.25K 1/4W F
R489	RM52742812	R,METAL 27.4K 1/4W F
R490	RM52741819	R,METAL 2.74K 1/4W F
R491	RM51003813	R,METAL 100K 1/4W F
R492,493	RM51002810	R,METAL 10K 1/4W F
R494-496	RM51009815	R,METAL 10 1/4W F
R497	RM56811816	R,METAL 6.81K 1/4W F
R498	RM53321814	R,METAL 3.32K 1/4W F
R499	RM51000812	R,METAL 100 1/4W F
R500	RM52211818	R,METAL 2.21K 1/4W F
R501	RM52219817	R,METAL 22.1 1/4W F
R502	RM53320810	R,METAL 332 1/4W F
R505	RM51502817	R,METAL 15K 1/4W F
R506	RM53320810	R,METAL 332 1/4W F
R507	RM54750812	R,METAL 475 1/4W F
R508	RM51502817	R,METAL 15K 1/4W F
R509	RM53320810	R,METAL 332 1/4W F
R510	RM54750812	R,METAL 475 1/4W F
R511	RM52219817	R,METAL 22.1 1/4W F
R512	RM51003813	R,METAL 100K 1/4W F
R513	RM55629812	R,METAL 56.2 1/4W F
R514,515	RM51003813	R,METAL 100K 1/4W F
R516	RM51009815	R,METAL 10 1/4W F
R517-519	RM51003813	R,METAL 100K 1/4W F
R520-522	RM51000812	R,METAL 100 1/4W F
R523	RM51002810	R,METAL 10K 1/4W F
R524	RM53320810	R,METAL 332 1/4W F
R525	RM53920813	R,METAL 392 1/4W F
R526	RM51002810	R,METAL 10K 1/4W F
R527	RM55628819	R,EMTAL 5.62 1/4W F
R528	RM53320810	R,METAL 332 1/4W F
R551	RM52219817	R,METAL 22.1 1/4W F
R552	RM51000812	R,METAL 100 1/4W F
R553	RM51003813	R,METAL 100K 1/4W F
R554	RM52219817	R,METAL 22.1 1/4W F
R555	RM55621813	R,METAL 5.62K 1/4W F
R556	RM51822812	R,METAL 18.2K 1/4W F
R557,558	RM52741819	R,METAL 2.74K 1/4W F
R559,560	RM52211818	R,METAL 2.21K 1/4W F
R561	RM51821819	R,METAL 1.82K 1/4W F
R562	RM52741819	R,METAL 2.74K 1/4W F
R563	RM54999814	R,METAL 49R9 1/4W F
R564,565	RM52211818	R,METAL 2.21K 1/4W F
R567	RM52212811	R,METAL 22.1K 1/4W F
R568	RM52219817	R,METAL 22.1 1/4W F
R569	RM51000812	R,METAL 100 1/4W F
R570	RM51003813	R,METAL 100K 1/4W F
R571	RM52219817	R,METAL 22.1 1/4W F
R572	RM51822812	R,METAL 18.2K 1/4W F
R573	RM55621813	R,METAL 5.62K 1/4W F
R574,575	RM52741819	R,METAL 2.74K 1/4W F
R576,577	RM52211818	R,METAL 2.21K 1/4W F



# Parts List

SYMBOL	PARTS NO.	DESCRIPTION
R578	RM51821819	R,METAL 1.82K 1/4W F
R579	RM52741819	R,METAL 2.74K 1/4W F
R580,581	RM52211818	R,METAL 2.21K 1/4 W F
R583	RM52212811	R,METAL 22.1K 1/4W F
R584	RM54999814	R,METAL 49R9 1/4W F
R585	RM54753813	R,METAL 475K 1/4W F
R586	RM52213815	R,METAL 221K 1/4W F
R587	RM51009815	R,METAL 10 1/4W F
R588	RM51002810	R,METAL 10K 1/4W F
R589	RM55621813	R,METAL 5.62K 1/4W F
R590	RM51002810	R,METAL 10K 1/4W F
R591	RM51009815	R,METAL 10 1/4W F
R592	RM51004817	R,METAL 1M 1/4W F
R593,594	RM54752810	R,METAL 47.5K 1/4W F
R595-597	RM54753813	R,METAL 475K 1/4W F
R598	RM51004817	R,METAL 1M 1/4W F
R599	RM51009815	R,METAL 10 1/4W F
R600,601	RM52211818	R,METAL 2,21K 1/4W F
R602	RM52002816	R,METAL 20K 1/4W F
R603	RM51212815	R,METAL 12.1K 1/4W F
R604	RM52002816	R,METAL 20K 1/4W F
R605	RM51212815	R,METAL 12.1K 1/4W F
R606	RM51003813	R,METAL 100K 1/4W F
R607	RM55621813	R,METAL 5.62K 1/4W F
R608,609	RM52211818	R,METAL 2.21K 1/4W F
R610	RM55621813	R,METAL 5.62K 1/4W F
R611	RM58251814	R,METAL 8.25K 1/4W F
R612	RM51002810	R,METAL 10K 1/4W F
R613	RM52219817	R,METAL 22.1 1/4W F
R614	RM51002810	R,METAL 10K 1/4W F
R615	RM52219817	R,METAL 22.1 1/4W F
R616,617	RM51212815	R,METAL 12.1K 1/4W F
R618	RM51003813	R,METAL 100K 1/4W F
R619,620	RM52211818	R,METAL 2.21K 1/4W F
R621	RM52002816	R,METAL 20K 1/4W F
R622	RM51212815	R,METAL 12.1K 1/4W F
R623	RM52002816	R,METAL 20K 1/4W F
R624	RM51212815	R,METAL 12.1K 1/4W F
R625	RM55621813	R,METAL 5.62K 1/4W F
R626	RM51003813	R,METAL 100K 1/4W F
R627,628	RM52211818	R,METAL 2.21K 1/4W F
R629	RM55621813	R,METAL 5.62K 1/4W F
R630	RM58251814	R,METAL 8.25K 1/4W F
R631	RM52219817	R,METAL 22.1 1/4W F
R632,633	RM51002810	R,METAL 10K 1/4W F
R634	RM52219817	R,METAL 22.1 1/4W F
R635,636	RM51212815	R,METAL 12.1K 1/4W F
R637	RM51003813	R,METAL 100K 1/4W F
R638	RM55621813	R,METAL 5.62K 1/4W F
R639	RM51009815	R,METAL 10 1/4W F
R640	RM91009929	R,METAL 10 1/2W J
R641	RM54750812	R,METAL 475 1/4W F
R642	RM51002810	R,METAL 10K 1/4W F
R643,644	RM51002810	R,METAL 10K 1/4W F
R647	RM52208819	R,METAL 2.21K 1/4W F
R648,649	RM56813813	R,METAL 681K 1/4W F
R650,651	RM54750812	R,METAL 475 1/4W F
C401-405	CE44706167	CAP,ELEC. 16V 47uF
C406	CC45009456	CAP,CERAMIC 50V 0.05uF
C407	CE41005257	CAP,ELEC. 25V 100uF
C408,409	CE44706167	CAP,ELEC. 16V 47UF
C410	CC45009456	CAP,CERAMIC 50V 0.05uF
C411	CC45009456	CAP,CERAMIC 50V 0.05uF
C412	CE04705164	CAP,ELEC. 16V 470uF
C413,414	CE44706167	CAP,ELEC. 16V 47uF
C415	CC45009456	CAP,CERAMIC 50V 0.05uF
C416,417	CE44706167	CAP,ELEC. 16V 47uF
C418	CM13309425	CAP,MYLAR 50V 333 J
C419	CE44706167	CAP,ELEC. 16V 47uF
C420	CM13309425	CAP,MYLAR 50V 333 J
C421	CE44706167	CAP,ELEC. 16V 47uF
C422	CM13309425	CAP,MYLAR 50V 333 J

SYMBOL	PARTS NO.	DESCRIPTION
C423	CE44706167	CAP,ELEC. 16V 47uF
C424	CM13309425	CAP,MYLAR 50V 333 J
C425	CE44706167	CAP,ELEC. 16V 47uF
C426	CM13309425	CAP,MYLAR 50V 333 J
C427	CE44706167	CAP,ELEC. 16V 47uF
C428	CC45009456	CAP,CERAMIC 50V 0.05uF
C429	CE41005257	CAP,ELEC. 25V 100uF
C430,431	CE44706167	CAP,ELEC. 16V 47uF
C432,433	CC45009456	CAP,CERAMIC 50V 0.05uF
C434	CE41005257	CAP,ELEC. 25V 100uF
C435,436	CE44706167	CAP,ELEC. 16V 47uF
C437,438	CC45009456	CAP,CERAMIC 50V 0.05uF
C439	CE41005257	CAP,ELEC. 25V 100uF
C440,441	CM13309425	CAP,MYLAR 50V 333 J
C442,443	CC45009456	CAP,CERAMIC 50V 0.05uF
C444	CE41005257	CAP,ELEC. 25V 100uF
C445,446	CM13309425	CAP,MYLAR 50V 333 J
C447	CC45009456	CAP,CERAMIC 50V 0.05uF
C448	CE45706167	CAP,ELEC. 16V 47uF
C449	CM13309425	CAP,MYLAR 50V 333 J
C450-452	CE41005257	CAP,ELEC. 25V 100uF
C453	CE44706167	CAP,ELEC. 16V 47uF
C454	CM11008422	CAP,MYLAR 50V 104 J
C455	CE41005257	CAP,ELEC. 25V 100uF
C456	CE44706167	CAP,ELEC. 16V 47uF
C457	CE41005257	CAP,ELEC. 25V 100uF
C458,459	CE44706167	CAP,ELEC. 16V 47uF
C460,461	CE41005257	CAP,ELEC. 25V 100uF
C462	CM13309425	CAP,MYLAR 50V 333 J
C463,464	CE41005257	CAP,ELEC. 25V 100uF
C465	CE44706167	CAP,ELEC. 16V 47uF
C466,467	CE41005257	CAP,ELEC. 25V 100uF
C468	CE44706167	CAP,ELEC. 16V 47uF
C469	CS45611420	CAP,STYROL 50V 560P
C470,471	CE41007503	CAP,ELEC. 50V 1uF
C472	CM13310427	CAP,MYLAR 50V 332 J
C473	CS45611420	CAP,STYROL 50V 560P
C474	CM12209423	CAP,MYLAR 50V 223 J
C475	CE42208504	CAP,ELEC. 50V 0.22uF
C476	CE04705255	CAP,ELEC. 25V 470uF
C477	CE41005257	CAP,ELEC. 25V 100uF
C478	CC41009426	CAP,CERAMIC 50V 0.01uF
C479	CC61008463	CAP,LAYER EC05ZD0104KDL
C480,481	CC43312435	CAP,CERAMIC 50V 33P
C482	CE44706167	CAP,ELEC. 16V 47uF
C483	CM13309425	CAP,MYLAR 50V 333 J
C484	CE41005257	CAP,ELEC. 25V 100uF
C485	CM11008422	CAP,MYLAR 50V 104 J
C486	CM13309425	CAP,MYLAR 50V 333J
C487	CE41005257	CAP,ELEC. 25V 100uF
C488	CE44706167	CAP,ELEC. 16V 47uF
C489	CE41005257	CAP,ELEC. 25V 100uF
C490	CC61008463	CAP,LAYER EC05ZD0104KDL
C491,492	CM11008422	CAP,MYLAR 50V 104 J
C191	CC43312435	CAP,CERAMIC 50V 33P
C192	CC43912438	CAP,CERAMIC 50V 39P
C501,502	CE41005257	CAP,ELEC. 25V 100uF
C503	CM14710425	CAP,MYLAR 50V 472 J
C504	CS43311421	CAP,STYROL 50V 330P
C505	CE41006506	CAP,ELEC. 50V 10uF
C506	CE41005257	CAP,ELEC. 25V 100uF
C507	CM15610426	CAP,MYLAR 50V 562 J
C508	CM12710422	CAP,MYLAR 50V 272 J
C509	CE41006500	CAP,ELEC. 50V 10uF
C510	CE41005257	CAP,ELEC. 25V 100uF
C511	CM16810423	CAP,MYLAR 50V 682 J
C512	CM15610426	CAP,MYLAR 50V 562 J
C513	CE44708504	CAP,ELEC. 50V 0.47uF
C514	CM11009426	CAP,MYLAR 50V 103 J
C515,516	CE41005257	CAP,ELEC. 25V 100uF
C517	CM14710425	CAP,MYLAR 50V 472 J
C518	CS43311421	CAP,STYROL 50V 330P
C519,520	CE41005257	CAP,ELEC. 25V 100uF

# Parts List

NOTE: THE COMPONENTS IDENTIFIED BY  $\Delta$  MARK ARE FOR SAFFTY. REPLACE ONLY WITH ORIGINAL PARTS. DO NOT SUBSTITUTE.

SYMBOL	PARTS NO.	DESCRIPTION
C521	CM15610426	CAP,MYLAR 50V 562 J
C522	CM12710422	CAP,MYLAR 50V 272 J
C523	CE41005257	CAP,ELEC. 25V 100uF
C524	CE41006500	CAP,ELEC. 50V 10uF
C525	CM16810423	CAP,MYLAR 50V 682 J
C526	CM15610426	CAP,MYLAR 50V 562 J
C527	CE44708504	CAP,ELEC. 50V 0.47uF
C528	CM11009426	CAP,MYLAR 50V 103 J
C529	CE44707500	CAP,ELEC. 50V 4.7uF
C530	CC61008463	CAP,LAYER EC05ZD0104KDL
C531,532	CE41006500	CAP,ELEC. 50V 10uF
C533-535	CC61008463	CAP,LAYER EC05ZD0104KDL
C536	CE41006500	CAP,ELEC. 50V 10uF
C537	CC61008463	CAP,LAYER EC05ZD0104KDL
C538	CE41006500	CAP,ELEC. 50V 10uF
C539-541	CC61008463	CAP,LAYER EC05ZD0104KDL
C542	CE41006500	CAP,ELEC. 50V 10uF
C543,544	CC41512433	CAP,CERAMIC 50V 15P
C545-547	CC61008463	CAP,CAP LAYER EC05ZD0104KDL
C548	CE41006500	CAP,ELEC. 50V 10uF
C549	CC61008463	CAP,CAP LAYER EC05ZD0104KDL
C550	CE41006500	CAP,ELEC. 50V 10uF
C551	CC61008463	CAP,CAP LAYER EC05ZD0104KDL
C552	CE44706167	CAP,ELEC. 16V 47uF
C553,554	CC61008463	CAP,CAP LAYER EC05ZD0104KDL
C555,556	CE41006500	CAP,ELEC. 50V 10uF
C557	CE41005257	CAP,ELEC. 25V 100uF
C558	CE41006500	CAP,ELEC. 50V 10uF
C559	CS44711420	CAP,STYROL 50V 470P
C560	CS46811428	CAP,STYROL 50V 680P
C561	CS41210420	CAP,STYROL 50V 1200P
C562	CE41007503	CAP,ELEC. 50V 1uF
C563	CE41005257	CAP,ELEC. 25V 100uF
C564	CE41006500	CAP,ELEC. 50V 10uF
C565	CE41005257	CAP,ELEC. 25V 100uF
C566	CM11010428	CAP,MYLAR 50V 102 J
C567	CS45111423	CAP,STYROL 50V 510P
C568	CE41005257	CAP,ELEC. 25V 100uF
C569	CM11010428	CAP,MYLAR 50V 102 J
C570	CS45111423	CAP,STYROL 50V 510P
C571	CE44707500	CAP,ELEC. 50V 4.7uF
C572	CE41006500	CAP,ELEC. 50V 10uF
C573	CE41005257	CAP,ELEC. 25V 100uF
C574	CS44711420	CAP,STYROL 50V 470P
C575	CS46811428	CAP,STYROL 50V 680P
C576	CS41210420	CAP,STYROL 50V 1200P
C577	CE41007503	CAP,ELEC. 50V 1uF
C579	CE41006500	CAP,ELEC. 50V 10uF
C580	CE41005257	CAP,ELEC. 25V 100uF
C581	CS45111423	CAP,STYROL 50V 510P
C582	CM11010428	CAP,MYLAR 50V 102 J
C583	CE41005257	CAP,ELEC. 25V 100uF
C584	CM11010428	CAP,MYLAR 50V 102 J
C585	CE44707500	CAP,ELEC. 50V 4.7uF
C586	CS45111423	CAP,STYROL 50V 510P
C587	CE41006500	CAP,ELEC. 50V 10uF
C588	CM12209423	CAP,MYLAR 50V 223 J
C589	CE04705255	CAP,ELEC. 25V 470uF
C590	CE41005257	CAP,ELEC. 25V 100uF
C591	CE04705255	CAP,ELEC. 25V 470uF
C592	CE41006500	CAP,ELEC. 50V 10uF
C597	CM11008422	CAP,MYLAR 50V 104 J
C598	CM11010428	CAP,MYLAR 50V 102 J
VR401	RV40000125	R,SEMI-FIXED VM6CKPV-1S-B 10KB
L401	LM00000632	MICRO INDUCTOR 4.7uH
L501,502	LM00000620	MICRO INDUCTOR 10uH
D401-417	DD80000021	DIODE IN4148-86
D505	DD80000021	DIODE IN4148-86
D506	DD20000478	DIODE RD5.6JS-T1
X501	DD60000362	CRYSTAL OSC. 16.9344MHZ
Q401,402	TR31000071	TRANSISTOR 2SC2274E
Q403	TR11000027	TRANSISTOR 2SA984KE/KF-AA

SYMBOL	PARTS NO.	DESCRIPTION
Q404,405	TR31000071	TRANSISTOR 2SC2274E/F-AA
Q406	TR11000027	TRANSISTOR 2SA984KE/KF-AA
Q407	TR31000071	TRANSISTOR 2SC2274E/F-AA
Q408	TR31000071	TRANSISTOR 2SC2274E/F-AA
Q409	TR31000071	TRANSISTOR 2SC2274E/F-AA
Q410	TR31000071	TRANSISTOR 2SC2274E/F-AA
Q411,412	TR31000071	TRANSISTOR 2SC2274E/F-AA
Q413	TR11000027	TRANSISTOR 2SA984KE/KF-AA
Q501	TR31000034	TRANSISTOR 2SC536G-NP-AA
Q502	TR11000015	TRANSISTOR 2SA608KF
Q503	TR31000034	TRANSISTOR 2SC536G-NP-AA
Q504	TR11000015	TRANSISTOR 2SA608KF
Q505	TR31000034	TRANSISTOR 2SC536G-NP-AA
Q506	TR40000150	TRANSISTOR 2SD600K(F)
Q507	TR31000034	TRANSISTOR 536G-NP-AA
Q508	TR11000015	TRANSISTOR 2SA608KF
Q509	TR31000034	TRANSISTOR 2SC536G-NP-AA
Q510	TR11000015	TRANSISTOR 2SA608KF
IC401	IC00004165	IC NJM2233BLA
IC402	IC00004128	IC LA7952
IC403	IC00004165	IC NJM2233BLA
IC404	IC00004128	IC LA7952
IC405	IC00004165	IC NJM2233BLA
IC406	IC00004128	IC LA7952
IC407	IC00004165	IC NJM2233BLA
IC408	IC00004128	IC LA7952
IC409	IC00004165	IC NJM2233BLA
IC410	IC00004128	IC LA7952
IC411	IC00004165	IC NJM2233BLA
IC412	IC00004128	IC LA7952
IC413	IC00003173	IC LVA519S
IC414	IC00003987	IC MB90083
IC415	IC00004025	IC TC74HC4050AP
IC501-504	IC00001292	IC NJM2041DD
IC505	IC00004013	IC AK5339VP
IC506	IC00003689	IC TC74HCU04AP
IC507	IC00003835	IC TC74HC74AP
IC508	IC00003434	IC YSS205B-F
IC509	IC00004177	IC LA36256AL-10
IC510	IC00002260	IC LB1641
IC511	IC00004130	IC AK4318-VS
IC512-515	IC00001292	IC NJM2041DD
S401,402	SH20000538	SLIDE SW 4TR-3179
X401	DD60000441	CRYSTAL OSC. 17.734475MHZ
	DD600004453	CRYSTAL OSC. 14.318180MHZ-U,C,A,J
<b>016E-1227B00T PCB ASSEMBLY</b>		
R001	RM52211818	R,METAL 2.21K 1/4W F
R002	RM54752810	R,METAL 47.5K 1/4W F
R003	RM52211818	R,METAL 2.21K 1/4W F
R004	RM54752810	R,METAL 47.5K 1/4W F
R006	RM52219817	R,METAL 22.1 1/4W F
R007	RM54752810	R,METAL 47.5K 1/4W F
R009	RM52219817	R,METAL 22.1 1/4W F
R010	RM54752810	R,METAL 47.5K 1/4W F
R012	RM52211818	R,METAL 2.21K 1/4W F
R013	RM54752810	R,METAL 47.5K 1/4W F
R014	RM52211818	R,METAL 2.21K 1/4W F
R015	RM54752810	R,METAL 47.5K 1/4W F
R017	RM52219817	R,METAL 22.1 1/4W F
R018,019	RM54752810	R,METAL 47.5K 1/4W F
R020	RM54752810	R,METAL 47.5K 1/4W F
R021	RM52219817	R,METAL 22.1 1/4W F
R022	RM52208819	R,METAL 2.21 1/4W F
R023	RM52211818	R,METAL 2.2K 1/4W F
R024	RM54752810	R,METAL 47.5K 1/4W F
R025	RM52211818	R,METAL 2.2K 1/4W F
R026	RM54752810	R,METAL 47.5K 1/4W F
R028	RM52219817	R,METAL 22.1 1/4W F
R029,030	RM54752810	R,METAL 47.5K 1/4W F
R031	RM52219817	R,METAL 22.1 1/4W F
R033	RM52208819	R,METAL 2.21 1/4W F

# Parts List

SYMBOL	PARTS NO.	DESCRIPTION
R034	RM52211818	R,METAL 2.21K 1/4W F
R035	RM54752810	R,METAL 47.5K 1/4W F
R036	RM52211818	R,METAL 2.21K 1/4W F
R037	RM54752810	R,METAL 47.5K 1/4W F
R038	RM52208819	R,METAL 2.21 1/4W F
R040	RM52219817	R,METAL 22.1 1/4W F
R041,042	RM54742810	R,METAL 47.5K 1/4W F
R043	RM52219817	R,METAL 22.1 1/4W F
R045	RM52211818	R,METAL 2.21K 1/4W F
R046	RM54752810	R,METAL 47.5K 1/4W F
R047	RM52211818	R,METAL 2.21K 1/4W F
R048	RM52208819	R,METAL 2.21 1/4W F
R049	RM54752810	R,METAL 47.5K 1/4W F
R051	RM52219817	R,METAL 22.1 1/4W F
R052,053	RM54752810	R,METAL 47.5K 1/4W F
R054	RM52219817	R,METAL 22.1 1/4W F
R057	RM52211818	R,METAL 2.21K 1/4W F
R058	RM54752810	R,METAL 47.5K 1/4W F
R059	RM52208819	R,METAL 2.21 1/4W F
R060	RM52211818	R,METAL 2.21K 1/4W F
R061	RM54752810	R,METAL 47.5K 1/4W F
R063	RM52219817	R,METAL 22.1 1/4W F
R064,065	RM54752810	R,METAL 47.5K 1/4W F
R066	RM52219817	R,METAL 22.1 1/4W F
R069	RM54752810	R,METAL 47.5K 1/4W F
R068	RM52211818	R,METAL 2.21K 1/4W F
R070	RM52211818	R,METAL 2.21K 1/4W F
R071	RM54752810	R,METAL 47.5K 1/4W F
R072	RM51000812	R,METAL 100 1/4W F
R073	RM52219817	R,METAL 22.1 1/4W F
R074,075	RM54752810	R,METAL 47.5K 1/4W F
R076	RM52219817	R,METAL 22.1 1/4W F
R077	RM51000812	R,METAL 100 1/4W F
R078,079	RM51001816	R,METAL 1K 1/4W F
R080	RM54752810	R,METAL 47.5K 1/4W F
R081,082	RM510001816	R,METAL 1K 1/4W F
R083	RM54752810	R,METAL 47.5K 1/4W F
R084,085	RM51003813	R,METAL 100K 1/4W F
R086,087	RM51001816	R,METAL 1K 1/4W F
R088-093	RM52219817	R,METAL 22.1 1/4W F
R094	RM51001816	R,METAL 1K 1/4W F
R095	RM54752810	R,METAL 47.5K 1/4W F
R096	RM51001816	R,METAL 1K 1/4W F
R097	RM54752810	R,METAL 47.5K 1/4W F
R099,100	RM52219817	R,METAL 22.1 1/4W F
R101,102	RM51001816	R,METAL 1K 1/4W F
R103	RM52208819	R,METAL 2.21 1/4W F
R104-107	RM51001816	R,METAL 1K 1/4W F
R108	RM52208819	R,METAL 2.21 1/4W F
R109-112	RM51001816	R,METAL 1K 1/4W F
R113	RM52208819	R,METAL 2.21 1/4W F
R114,115	RM51002816	R,METAL 10K 1/4W F
R116-124	RM51002810	R,METAL 10K 1/4W F
R125,126	RM52219817	R,METAL 22.1 1/4W F
R127	RM54750812	R,METAL 475 1/4W F
R128	RM55620810	R,METAL 562 1/4W F
R129	RM54752810	R,METAL 47.5K 1/4W F
R130	RM54750812	R,METAL 475 1/4W F
R131	RM55620810	R,METAL 562 1/4W F
R132	RM54752810	R,METAL 47.5K 1/4W F
R133	RM52742812	R,METAL 27.4K 1/4W F
R134,135	RM54752810	R,METAL 47.5K 1/4W F
R136	RM52742812	R,METAL 27.4K 1/4W F
R137	RM56810812	R,METAL 681 1/4W F
R138,139	RM51005810	R,METAL 10M 1/4W F
R140	RM56810812	R,METAL 681 1/4W F
R141,142	RM52210814	R,METAL 221 1/4W F
R143	RM51003813	R,METAL 100K 1/4W F
R145	RM51003813	R,METAL 100K 1/4W F
R146	RM54751816	R,METAL 4.75K 1/4W F
R147	RM51001816	R,METAL 1K 1/4W F
R148	RM51003813	R,METAL 100K 1/4W F

SYMBOL	PARTS NO.	DESCRIPTION
R149	RM51001816	R,METAL 1K 1/4W F
R150	RM51003813	R,METAL 100K 1/4W F
R151,152	RM51000812	R,METAL 100 1/4W F
R153,154	RM51001816	R,METAL 1K 1/4W F
R155	RM54752810	R,METAL 47.5K 1/4W F
R156	RM54750812	R,METAL 475 1/4W F
R157,158	RM54752810	R,METAL 47.5K 1/4W F
R159	RM54750812	R,METAL 475 1/4W F
R160	RM52741819	R,METAL 2.74K 1/4W F
R161	RM52213815	R,METAL 221K 1/4W F
R162	RM52741819	R,METAL 2.74K 1/4W F
R163	RM52213815	R,METAL 221K 1/4W F
R164,165	RM52219817	R,METAL 22.1 1/4W F
R166-168	RM51002810	R,METAL 10K 1/4W F
R169-175	RM51001816	R,METAL 1K 1/4W F
R176-179	RM51009815	R,METAL 10 1/4W F
R180-185	RM54752810	R,METAL 47.5K 1/4W F
R186	RM51001816	R,METAL 1K 1/4W F
R187	RM56811816	R,METAL 6.81K 1/4W F
R188	RM51001816	R,METAL 1K 1/4W F
R189	RM56811816	R,METAL 6.81K 1/4W F
R190	RM51001816	R,METAL 1K 1/4W F
R191	RM56811816	R,METAL 6.81K 1/4W F
R192,193	RM51001816	R,METAL 1K 1/4W F
R194	RM51001816	R,METAL 1K 1/4W F
R195	RM51001816	R,METAL 1K 1/4W F
R196,197	RM51001816	R,METAL 1K 1/4W F
R198,199	RM51009818	R,METAL 10 1/4W F
R200,201	RM54752810	R,METAL 47.5K 1/4W F
R202,203	RM51009815	R,METAL 10 1/4W F
R204-206	RM54752810	R,METAL 47.5K 1/4W F
R207,208	RM51001816	R,METAL 1K 1/4W F
R209	RM56811816	R,METAL 6.81K 1/4W F
R210	RM51001816	R,METAL 1K 1/4W F
R211,212	RM56811816	R,METAL 6.81K 1/4W F
R213	RM54752810	R,METAL 47.5K 1/4W F
R214	RM52212811	R,METAL 22.1K 1/4W F
R215	RM51002810	R,METAL 10K 1/4W F
R216	RM54752810	R,METAL 47.5K 1/4W F
R217	RM51002810	R,METAL 10K 1/4W F
R218	RM52212811	R,METAL 22.1K 1/4W F
R219	RM51001816	R,METAL 1K 1/4W F
R220	RM52211818	R,METAL 2.21K 1/4W F
R221,222	RM52219817	R,METAL 22.1 1/4W F
R223	RM51002810	R,METAL 10K 1/4W F
R224,225	RM54742810	R,METAL 47.5K 1/4W F
R226	RM51002810	R,METAL 10K 1/4W F
R227,228	RM52212811	R,METAL 22.1K 1/4W F
R229	RM55111811	R,METAL 5.11K 1/4W F
R230	RM52211818	R,METAL 2.21K 1/4W F
R231	RM54752810	R,METAL 47.5K 1/4W F
R232,233	RM52219817	R,METAL 22.1 1/4W F
R234	RM54752810	R,METAL 47.5K 1/4W F
R235	RM54751816	R,METAL 4.75K 1/4W F
R236-238	RM54752810	R,METAL 47.5K 1/4W F
R239	RM51001816	R,METAL 1K 1/4W F
R240,241	RM52211818	R,METAL 2.21K 1/4W F
R242	RM51001816	R,METAL 1K 1/4W F
R243,244	RM54752810	R,METAL 47.5K 1/4W F
R245,246	RM52219817	R,METAL 22.1 1/4W F
R247	RM51001816	R,METAL 1K 1/4W F
R248	RM54752810	R,METAL 47.5K 1/4W F
R249,250	RM52219817	R,METAL 22.1 1/4W F
R251	RM51001816	R,METAL 1K 1/4W F
R252	RM54752810	R,METAL 47.5K 1/4W F
R253	RM52212811	R,METAL 22.1K 1/4W F
R254	RM51002810	R,METAL 10K 1/4W F
R255	RM52212811	R,METAL 22.1K 1/4W F
R256	RM51001816	R,METAL 1K 1/4W F
R257,258	RM52211818	R,METAL 2.21K 1/4W F
R259	RM51001816	R,METAL 1K 1/4W F
R260	RM52212811	R,METAL 22.1K 1/4W F

# Parts List

NOTE: THE COMPONENTS IDENTIFIED BY  $\Delta$  MARK ARE FOR SAFFTY. REPLACE ONLY WITH ORIGINAL PARTS. DO NOT SUBSTITUTE.

SYMBOL	PARTS NO.	DESCRIPTION
R261	RM51002810	R,METAL 10K 1/4W F
R262	RM52211818	R,METAL 22.1K 1/4W F
R263	RM54752810	R,METAL 47.5K 1/4W F
R264	RM51002810	R,METAL 10K 1/4W F
R265	RM54752810	R,METAL 47.5K 1/4W F
R266,267	RM52219817	R,METAL 22.1 1/4W F
R268,269	RM54752810	R,METAL 47.5K 1/4W F
R270	RM51002810	R,METAL 10K 1/4W F
R271	RM52212811	R,METAL 22.1K 1/4W F
R272	RM51002810	R,METAL 10K 1/4W F
R273	RM51000812	R,METAL 100 1/4W F
R274,275	RM51003813	R,METAL 100K 1/4W F
R276	RM51000812	R,METAL 100 1/4W F
R277	RM51002810	R,METAL 10K 1/4W F
R278	RM52212811	R,METAL 22.1K 1/4W F
R279	RM51001816	R,METAL 1K 1/4W F
R280	RM53322818	R,METAL 33.2K 1/4W F
R281	RM52219817	R,METAL 22.1 1/4W F
R283	RM51502817	R,METAL 15K 1/4W F
R284	RM59091818	R,METAL 9.09K 1/4W F
R285	RM55111811	R,METAL 5.11K 1/4W F
R286	RM52211818	R,METAL 2.21K 1/4W F
R287	RM56811816	R,METAL 6.81K 1/4W F
R288	RM51282812	R,METAL 18.2K 1/4W F
R289	RM51002810	R,METAL 10K 1/4W F
R290	RM51822812	R,METAL 18.2K 1/4W F
R291	RM54751816	R,METAL 4.75K 1/4W F
R292	RM53322818	R,METAL 33.2K 1/4W F
R293	RM51001816	R,METAL 1K 1/4W F
R294	RM52212811	R,METAL 22.1K 1/4W F
R295,296	RM52219817	R,METAL 22.1 1/4W F
R297	RM51002810	R,METAL 10K 1/4W F
R298	RM56811816	R,METAL 6.81K 1/4W F
R299	RM54751816	R,METAL 4.75K 1/4W F
R300	RM52211818	R,METAL 2.21K 1/4W F
R301	RM51822812	R,METAL 18.2K 1/4W F
R302	RM51002810	R,METAL 10K 1/4W F
R303	RM51822812	R,METAL 18.2K 1/4W F
R304	RM54751816	R,METAL 4.75K 1/4W F
R305	RM51001816	R,METAL 1K 1/4W F
R306,307	RM52219817	R,METAL 22.1 1/4W F
R308	RM52212811	R,METAL 22.1K 1/4W F
R309	RM53322818	R,METAL 33.2K 1/4W F
R310	RM51002810	R,METAL 10K 1/4W F
R311	RM55111811	R,METAL 5.11K 1/4W F
R312	RM52211818	R,METAL 2.21K 1/4W F
R313	RM56811816	R,METAL 6.81K 1/4W F
R314,315	RM51822812	R,METAL 18.2K 1/4W F
R316	RM51002810	R,METAL 10K 1/4W F
R317	RM54751816	R,METAL 4.75K 1/4W F
R318,319	RM52219817	R,METAL 22.1 1/4W F
R320	RM51002810	R,METAL 10K 1/4W F
R322-326	RM51002810	R,METAL 10K 1/4W F
R327	RM54753813	R,METAL 475K 1/4W F
R328	RM51009815	R,METAL 10 1/4W F
R330,331	RM51002810	R,METAL 10K 1/4W F
R332	RM54752810	R,METAL 47.5K 1/4W F
R333	RM54758811	R,METAL 4R75 1/4W F
R334	RM54752810	R,METAL 47.5K 1/4W F
R335	RM52212811	R,METAL 22.1K 1/4W F
R336	RM54752810	R,METAL 47.5K 1/4W F
R337	RM51003813	R,METAL 100K 1/4W F
R339	RM51003813	R,METAL 100K 1/4W F
R341,342	RM51003813	R,METAL 100K 1/4W F
R343	RM52219817	R,METAL 22.1 1/4W F
R345,346	RM54752810	R,METAL 47.5K 1/4W F
R347,348	RM54750812	R,METAL 475 1/4W F
R349	RM51000812	R,METAL 100 1/4W F
R350	RM52219817	R,METAL 22.1 1/4W F
R351,352	RM51000812	R,METAL 100 1/4W F
R353	RM51001816	R,METAL 1K 1/4W F
R354	RM52211818	R,METAL 2.21K 1/4W F
R355	RM51003813	R,METAL 100K 1/4W F

SYMBOL	PARTS NO.	DESCRIPTION
R356,357	RM52219817	R,METAL 22.1 1/4W F
R359	RM51002810	R,METAL 10K 1/4W F
R360	RM52740815	R,METAL 274 1/4W F
R361	RM51210818	R,METAL 121 1/4W F
R362	RM52211818	R,METAL 2.21K 1/4W F
R363	RM51003813	R,METAL 100K 1/4W F
R365	RM52740815	R,METAL 274 1/4W F
R366	RM51210818	R,METAL 121 1/4W F
R367	RM51002810	R,METAL 10K 1/4W F
R368	RM52211818	R,METAL 2.21K 1/4W F
R369	RM51003813	R,METAL 100K 1/4W F
R370	RM51002810	R,METAL 10K 1/4W F
R371,372	RM52219817	R,METAL 22.1 1/4W F
R374	RM52740815	R,METAL 274 1/4W F
R375	RM51210818	R,METAL 121 1/4W F
R376	RM52740815	R,METAL 274 1/4W F
R378	RM51210818	R,METAL 121 1/4W F
R379	RM51002810	R,METAL 10K 1/4W F
R380	RM52211818	R,METAL 2.21K 1/4W F
R381,382	RM51003813	R,METAL 100K 1/4W F
R383	RM52211818	R,METAL 2.21K 1/4W F
R384,385	RM52219817	R,METAL 22.1 1/4W F
R386	RM51002810	R,METAL 10K 1/4W F
R388	RM52740815	R,METAL 274 1/4W F
R389	RM51002810	R,METAL 10K 1/4W F
R390	RM52740815	R,METAL 274 1/4W F
R391,392	RM51210818	R,METAL 121 1/4W F
R394	RM51003813	R,METAL 100K 1/4W F
R393	RM52211818	R,METAL 2.21K 1/4W F
R396	RM51003813	R,METAL 100K 1/4W F
R397	RM52213815	R,METAL 221K 1/4W F
R398	RM54753813	R,METAL 475K 1/4W F
R399	RM54759815	R,METAL 47.5 1/4W F
R1010-1016	RM51002810	R,METAL 10K 1/4W F
R1050,1051	RM51009815	R,METAL 10 1/4W F
R1052,1053	RM51002810	R,METAL 10K 1/4W F
R1054	RM51009815	R,METAL 10 1/4W F
R1055	RM54752810	R,METAL 47.5K 1/4W F
C101,102	CS44711420	CAP,STYROL 50V 470P
C103,104	CE41005257	CAP,ELEC. 25V 100uF
C105	CS44711420	CAP,STYROL 50V 470P
C106	CY21008428	CAP,LAYER 50MSA104 J
C107	CS44711420	CAP,STYROL 50V 470P
C108,109	CE41005257	CAP,ELEC. 25V 100uF
C110	CS44711420	CAP,STYROL 50V 470P
C111	CC41009462	CAP,CERAMIC 50V 0.01uF
C112	CS44711420	CAP,STYROL 50V 470P
C113,114	CE41005257	CAP,ELEC. 25V 100uF
C115	CC41009462	CAP,CERAMIC 50V 0.01uF
C117	CS44711420	CAP,STYROL 50V 470P
C118,119	CE41005257	CAP,ELEC. 25V 100uF
C120,121	CS44711420	CAP,STYROL 50V 470P
C122,123	CE41005257	CAP,ELEC. 25V 100uF
C124,125	CS44711420	CAP,STYROL 50V 470P
C126,127	CE41005257	CAP,ELEC. 25V 100uF
C128	CS44711420	CAP,STYROL 50V 470P
C129	CC41009462	CAP,CERAMIC 50V 0.01uF
C130	CS44711420	CAP,STYROL 50V 470P
C131,132	CE41005257	CAP,ELEC. 25V 100uF
C133,134	CS41011422	CAP,STYROL 50V 100P
C135-144	CE41005257	CAP,ELEC.25V 100uF
C145,146	CM18210423	CAP,MYLAR 50V 822 J
C149	CM11010428	CAP,MYLAR 50V 102 J
C150	CM11009426	CAP,MYLAR 50V 103 J
C151	CY21008428	CAP,LAYER 50MSA104 J
C154	CY21008428	CAP,LAYER 50MSA104 J
C155-160	CS41011422	CAP,STYROL 50V 100P
C161	CC41009462	CAP,CERAMIC 50V 0.01uF
C162	CS41011422	CAP,STYROL 50V 100P
C163	CE41006250	CAP,ELEC. 25V 10uF
C164	CS41011422	CAP,STYROL 50V 100P
C165	CE41006250	CAP,ELEC. 25V 10uF
C166,167	CE04705164	CAP,ELEC. 16V 470uF
C168,169	CS44712423	CAP,STYROL 50V 47P

# Parts List

SYMBOL	PARTS NO.	DESCRIPTION
C170-177	CE41005257	CAP,ELEC. 25V 100uF
C178	CS44712412	CAP,STYROL 50V 47P
C179	CM15609424	CAP,MYLAR 50V 563 J
C180,181	CE41005257	CAP,ELEC. 25V 100uF
C182,183	CE44707251	CAP,ELEC. 25V 4.7uF
C184,185	CM14710425	CAP,MYLAR 50V 472 J
C186,187	CM15609424	CAP,MYLAR 50V 563 J
C188,189	CM14710425	CAP,MYLAR 50V 472 J
C190,191	CM15609424	CAP,MYLAR 50V 563 J
C192,193	CS44712423	CAP,MYLAR 50V 47P
C194-197	CE41005257	CAP,ELEC. 25V 100uF
C198,199	CM14710425	CAP,MYLAR 50V 472 J
C200	CM15609424	CAP,MYLAR 50V 563 J
C201,202	CM11010428	CAP,MYLAR 50V 102 J
C203,204	CE41005257	CAP,ELEC. 25V 100uF
C205,206	CE44708504	CAP,ELEC. 50V 0.47uF
C207,208	CE41007503	CAP,ELEC. 50V 1uF
C209,210	CM15609424	CAP,MYLAR 50V 563 J
C211,212	CE41005257	CAP,ELEC. 25V 100uF
C213,214	CM12210425	CAP,MYLAR 50V 222 J
C215-218	CE41007503	CAP,ELEC. 50V 1uF
C219,220	CE41005257	CAP,ELEC. 25V 100uF
C221,222	CE44708504	CAP,ELEC. 50V 0.47uF
C223,224	CE41007503	CAP,ELEC. 50V 1uF
C225-228	CM15609424	CAP,MYLAR 50V 563 J
C229,230	CE41005257	CAP,ELEC. 25V 100uF
C231,232	CM14710425	CAP,MYLAR 50V 472 J
C234,235	CS41011422	CAP,STYROL 50V 100P
C236,237	CE41007503	CAP,STYROL 50V 1uF
C238,239	CE41005257	CAP,STYROL 25V 100uF
C240	CE44707251	CAP,ELEC. 25V 4.7uF
C242,243	CE41005257	CAP,ELEC. 25V 100uF
C244,245	CM11210429	CAP,MYLAR 50V 122 J
C246	CM13310427	CAP,MYLAR 50V 332 J
C247,248	CE41005257	CAP,ELEC. 25V 100uF
C249,250	CM11210429	CAP,MYLAR 50V 122 J
C251	CM13301427	CAP,MYLAR 50V 332 J
C252,253	CE41005257	CAP,ELEC. 25V 100uF
C254,255	CM11210429	CAP,MYLAR 50V 122 J
C256	CM13310427	CAP,MYLAR 50V 332 J
C257-260	CE41005257	CAP,ELEC. 25V 100uF
C261-263	CE44707251	CAP,ELEC. 25V 4.7uF
C264	CE41005257	CAP,ELEC. 25V 100uF
C265	CM11008422	CAP,MYLAR 50V 104 J
C266	CE41006250	CAP,ELEC. 25V 10uF
C267	CE41005257	CAP,ELEC. 25V 100uF
C268	CM11008422	CAP,MYLAR 50V 104 J
C269	CE42207500	CAP,ELEC. 50V 2.2uF
C271,272	CE41005257	CAP,ELEC. 25V 100uF
C273,274	CS46811428	CAP,STYROL 50V 680P
C275,276	CE41005257	CAP,ELEC. 25V 100uF
C278,279	CS46811428	CAP,STYROL 50V 680P
C280,281	CE41005257	CAP,ELEC. 25V 100uF
C282,283	CS46811428	CAP,STYROL 50V 680P
C284	CE42206167	CAP,ELEC.16V 22uF
C285	CS43010421	CAP,STYROL 50V 3000P
C286	CE42206167	CAP,ELEC.16V 22uF
C287	CS43010421	CAP,STYROL 50V 3000P
C288	CE42206167	CAP,ELEC.16V 22uF
C289	CS43010421	CAP,STYROL 50V 3000P
C290	CE42206167	CAP,ELEC.16V 22uF
C291	CS43010421	CAP,STYROL 50V 3000P
C292	CE42206167	CAP,ELEC.16V 22uF
C293	CS43010421	CAP,STYROL 50V 3000P
C294	CE42206167	CAP,ELEC.16V 22uF
C295	CS43010421	CAP,STYROL 50V 3000P
C296,297	CE04705164	CAP,ELEC. 16V 470uF
C301-304	CC41009164	CAP,CERAMIC 500V 0.01uF
C305,306	CE02204160	CAP,ELEC. 16V 2200uF
C307-314	CE41005257	CAP,ELEC. 25V 100uF
C320,321	CC41009462	CAP,CERAMIC 50V 0.01uF

SYMBOL	PARTS NO.	DESCRIPTION
C323	CE41005257	CAP,ELEC. 25V 100uF
C324	CC41009462	CAP,CERAMIC 50V 0.01uF
VR101,102	RV10001929	R,VARIABLE 4TR-3178 20KbX3
S101-103	SH13000498	3 KEY PUSH SW 4TR-3170
DP101	SA00003379	D-SUB CONNEX.DBL25PBTk1NS
D101,102	DD80000010	DIODE IN4003-TB
D105-109	DD80000021	DIODE IN4148-86
D111,112	DD80000021	DIODE IN4148-86
D201-204	DD80000010	DIODE IN4003-TB
Q101-106	TR31000149	TRANSISTOR 2SC2878-A/B
Q107	TR11000064	TRANSISTOR 2SA1345-AC
Q108	TR31000101	TRANSISTOR 2SC3399-AC
Q109	TR11000064	TRANSISTOR 2SA1345-AC
Q110	TR31000101	TRANSISTOR 2SC3399-AC
Q111	TR11000064	TRANSISTOR 2SA1345-AC
Q112	TR31000101	TRANSISTOR 2SC3399-AC
Q113	TR11000064	TRANSISTOR 2SA1345-AC
Q114	TR31000101	TRANSISTOR 2SC3399-AC
Q117	TR11000064	TRANSISTOR 2SA1345-AC
Q118	TR31000101	TRANSISTOR 2SC3399-AC
Q119	TR11000064	TRANSISTOR 2SA1345-AC
Q120	TR31000101	TRANSISTOR 2SC3399-AC
Q121	TR11000064	TRANSISTOR 2SA1345-AC
Q122,223	TR31000101	TRANSISTOR 2SC3399-AC
Q125	TR11000064	TRANSISTOR 2SA1345-AC
Q126	TR31000101	TRANSISTOR 2SC3399-AC
Q133	TR11000064	TRANSISTOR 2SA1345-AC
Q134	TR31000101	TRANSISTOR 2SC3399-AC
Q137	TR11000064	TRANSISTOR 2SA1345-AC
Q136	TR31000101	TRANSISTOR 2SC3399-AC
Q138	TR51000044	TRANSISTOR 2SK366-BL
Q201	DD70000061	PHOTO COUPLER PC817B
IC101-109	IC00002296	IC NJM5532DD
IC110,111	IC00001292	IC NJM2041DD
IC112	IC00003150	IC TC9213P
IC113	IC00000019	IC LA6458D
IC114-116	IC00002983	IC TC9163N
IC117-121	IC00002296	IC NJM5532DD
IC122-125	IC00001292	IC NJM 2041DD
IC126	IC00002296	IC NJM5532DD
IC127	IC00002983	IC TC9163N
IC128-130	IC00002296	IC NJM5532DD
IC131,132	IC00001772	IC LC4966
IC133-135	IC00002296	IC NJM5532DD
IC136	IC00004141	IC SSM2160-P
IC201	IC00004207	IC NJM7912FA
IC202	IC00004396	IC NJM7812FA
IC203	IC00003630	IC NJM7805FA
IC204	IC00004426	IC NJM7905FA
IC205	IC00004207	IC NJM7912FA
IC206	IC00004396	IC NJM7812FA
IC207	IC00004207	IC NJM7912FA
IC208	IC00004396	IC NJM7812FA
<b>E-1228A01T PCB ASSEMBLY</b>		
R952	RM51829818	R,METAL 18.2 1/4W F
R953	RM52212811	R,METAL 22.1K 1/4W F
R954	RM51002810	R,METAL 10K 1/4W F
R955,956	RM55629812	R,METAL 56.2 1/4W F
C951	CK00000035	SPARK KILLER DE7150F472M
C953-956	CC41009164	CAP,CERAMIC 500V 0.01uF
C957	CE01004503	CAP,ELEC. 50V 1000uF
C958,959	CE13304547	CAP,ELEC. 35V 3300uF
C960	CE01004254	CAP,ELEC. 25V 1000uF
C961	CE41005257	CAP,ELEC. 25V 100uF
C962-967	CC41009164	CAP,CERAMIC 500V 0.01uF
L951	LC23560006	LINE FILTER COIL TRL-356
F951,952	FU24000070	FUSE 250V 2.0A (U,C,A,J)
	FU23000323	FUSE 250V T 2A
RY951	LY00000319	RELAY G4W-1112P-VDE-TV8





# Parts List

NOTE: THE COMPONENTS IDENTIFIED BY  $\Delta$  MARK ARE FOR SAFFTY. REPLACE ONLY WITH ORIGINAL PARTS. DO NOT SUBSTITUTE.

SYMBOL	PARTS NO.	DESCRIPTION
RY952,953	LY00000289	RELAY VB-24SMCU-E $\Delta$
Q951	TR10000047	TRANSISTOR 2SB631KE/KF
Q952	TR31000101	TRANSISTOR 2SC3399-AC
D951	DD80000021	DIODE IN4148-86
D952-957	DD80000010	DIODE IN4003-TB
D958-959	DD80000021	DIODE IN4148-86
D960	DD10000135	DIODE KBPC-602 $\Delta$
IC951	IC00003630	IC NJM7805FA
<b>E-1228102T PCB ASSEMBLY</b>		
C968,969	CE02204160	CAP,ELEC. 16V 2200uF $\Delta$
C975-978	CC41009164	CAP,CERAMIC 500V 0.01uF
C970-974	CE41005257	CAP,ELEC. 25V 100uF
IC952	IC00004359	IC NJM7906FA
IC953	IC00002077	IC LM7806
IC954	IC00003630	IC NJM7805FA
IC955	IC00004396	IC NJM7812FA
D961	DD10000123	DIODE W02 $\Delta$
<b>E-1228A03T PCB ASSEMBLY</b>		
C979	CM14709423	CAP,MYLAR 50V 473 J
IC956	IC00002030	IC SBX1610-02
<b>E-1228A04T PCB ASSEMBLY</b>		
R957	RM54750812	R,METAL 475 1/4W F
R958	RM51000812	R,METAL 100 1/4W F
R960	RM52742812	R,METAL 27.4K 1/4W F
VR951	RV10001917	R,VARIABLE 4TR-3189 50KBx2
<b>E-1228A05T PCB ASSEMBLY</b>		
R959	RM56810812	R,METAL 681 1/4W F
S951	SH11000483	1 KEY PUSH 4TR-3011
<b>E-1229A00T PCB ASSEMBLY</b>		
R651	RM54753813	R,METAL 475K 1/4W F
R652	RM51004817	R,METAL 1M 1/4W F
R653	RM58250810	R,METAL 825 1/4W F
R654	RM54752810	R,METAL 47.5K 1/4W F
R655,656	RM54753813	R,METAL 475K 1/4W F
R657	RM51009815	R,METAL 10 1/4W F
R658	RM54751816	R,METAL 4.75K 1/4W F
R659,660	RM52212811	R,METAL 22.1K 1/4W F
R661-663	RM54751816	R,METAL 4.75K 1/4W F
R664,665	RM52212811	R,METAL 22.1K 1/4W F
R666	RM51009815	R,METAL 10 1/4W F
R667	RM55621813	R,METAL 5.62K 1/4W F
R668	RM51503810	R,METAL 150K 1/4W F
R669	RM52213815	R,METAL 221K 1/4W F
R670	RM51002810	R,METAL 10K 1/4W F
R671-673	RM58250810	R,METAL 825 1/4W F
R674	RM54752810	R,METAL 47.5K 1/4W F
R675-681	RM54750812	R,METAL 475 1/4W F
R682	RM51540818	R,METAL 154 1/4W F
R683	RM54752810	R,METAL 47.5K 1/4W F
R684,685	RM58250810	R,METAL 825 1/4W F
R686	RN24701084	THICK FILM RS NETWORK SE8472 JFU
R687,688	RM54752810	R,METAL 47.5K 1/4W F
R689	RM51002810	R,METAL 10K 1/4W F
R690	RM54753813	R,METAL 475K 1/4W F
C651	CE41005166	CAP,ELEC. 16V 100uF
C652,653	CC61008463	CAP,LAYER CERAMIC EC05ZD0104KDL
C654	CE41005166	CAP,ELEC. 16V 100uF
C655	CE43311431	CAP,ELEC. 50V 330P
C656	CE41007503	CAP,ELEC. 50V 1uF
C657	CC61008463	CAP,LAYER CERAMIC EC05ZD0104KDL
C658,659	CC43312435	CAP,CERAMIC 50V 33P
C660	CC61008463	CAP,LAYER CERAMIC EC05ZD0104KDL

SYMBOL	PARTS NO.	DESCRIPTION
C661	CE41005166	CAP,ELEC. 16V 100uF
C662	CS44712423	CAP,STYROL 50V 47P
C663	CE41005166	CAP,ELEC. 16V 100uF
C664	CC61008463	CAP,LAYER CERAMIC EC05ZD0104KDL
X651	LF00000490	CERAMIC RESONATOR CSA4.19MG
D651-662	DD40001373	LED LTL-4266N
D663-670	DD40000850	LED LTL-4232N
D671-673	DD40001373	LED LTL-4266N
F675	DD80000021	DIODE IN4148-86
D680-682	DD80000021	DIODE IN4148-86
IC651	IC00004116	IC D75516GF-625-3B9
IC652	IC00003793	IC M51953BL
IC653	IC00003975	IC PIC16C56-RC/P
IC654	IC00003756	IC TC74HC238AP
Q651-659	TR31000101	TRANSISTOR 2SC3399-AC
Q660	TR11000064	TRANSISTOR 2SA1345-AC
Q661	TR31000034	TRANSISTOR 2SC536G
Q662	TR11000064	TRANSISTOR 2SA1345-AC
Q663	TR31000101	TRANSISTOR 2SC3399-AC
S651-662	SH60000240	KEY BOARD SW 4TR-2343
<b>TX606111 PCB ASSEMBLY</b>		
R1-R11	RM51002810	R,METAL 10K 1/4W F
R12	RM54753813	R,METAL 475K 1/4W F
R13	RM51003813	R,METAL 100K 1/4W F
R14	RM51004817	R,METAL 1M 1/4W F
R15,R16	RM51000812	R,METAL 100 1/4W F
R17	RM51001816	R,METAL 1K 1/4W F
R18	RM51003813	R,METAL 100K 1/4W F
R20,R21	RM51002810	R,METAL 10K 1/4W F
R22,R23	RM51003813	R,METAL 100K 1/4W F
R25	RM51004817	R,METAL 1M 1/4W F
D1,D2	DD80000021	DIODE IN4148-86
Q1	TR31000034	TRANSISTOR 2SC536G
Q2	TR11000064	TRANSISTOR 2SA1345-AC
Q3	TR11000015	TRANSISTOR 2SA608KF
Q4	TR31000034	TRANSISTOR 2SC536G
Q5	TR11000015	TRANSISTOR 2SA608KF
C1,C2	CE41005257	CAP,ELEC. 25V 100uF
C3,C4	CE41006500	CAP,ELEC. 50V 10uF
C5	CC41009462	CAP,CERAMIC 50V 0.01uF
IC1,IC2	IC00001772	IC LC4966
<b>OTHERS</b>		
AB00000870		PAINTED BOTTOM BOARD QZ3-05A00T
AF60000038		FRONT CHASSIS QZ3-03B00T
AM00002335		SUB CHASSIS QZ3-04A00T
AR60000047		PRINTED REAR CHASSIS TR-682A
AS01000531		SIDE CHASSIS QZ4-07A00T
PT32510100		POWER TRANSFORMER TT-325NF $\Delta$
BC00000532		CYLINDER BUSH 4TR-2187#8 6Fx7H
BC00000891		CYLINDER BUSH 4TVL-8#23 6Fx36H
BC00000908		CYLINDER BUSH 4TVL-8#24 6Fx32.2H
FT00000229		PLASTIC FOOT 4TSH-19#2 50Fx14H
SB00001319		P.V.C SHIELD PLATE 4TR-3229
SB00001332		P.V.C SHIELD PLATE 4TR-3242
SP10006211		P.C.B SUPPORT PK4-28A00T
SR00001217		RUBBER SAPCER 4TR-2900#2
SR00001280		P.T RUBBER SPACER 4TR-2900#3
CD00000218		AC CORD SPT-2 AWG#18 4TR-670#4 $\Delta$
CD00000048		AC POWER CORD 4TR-1037 $\Delta$
CD00000528		AC CORD H03VVH2-F 4TR-3083 $\Delta$
CD00000322		AC POWER CORD OKA 4TR-2757 $\Delta$
CD00000085		AC POWER CORD C-2504A $\Delta$
CD00000115		AC POWER CORD C-3763-T $\Delta$
NP00001949		NAME STICKER AC 120V 4TR-2828#1
NP00002012		TNP-382
		NAME STICKER AC 100V 4TR-2828#6
		TNP-391

# Parts List

SYMBOL	PARTS NO.	DESCRIPTION
	NP00002140	NAME STICKER AC 220V-240V 4TR-2828#11 TNP-398
	SA00001450	AC OUTLET SOCKET S-I6519 
	SA00001796	AC OUTLET SOCKET S-I6536#1 
	SA00001980	AC OUTLET SOCKET S2-741T-110/120 
	SC00000027	AC CORD STOPPER SR-4N-4 
	SP30000884	ACO MASK 4TR-3235
	AA60000153	FRONT PANEL QZ3-01A00T TFP-758
	AW00000654	RJ SENSOR WINDOW PT-12A00T
	BU00001145	POWER RING W/LED 4TQF-13
	BU00001124	KNOB RING PR4-12A00T 46F
	KB20002681	POWER BUTTON 4TQF-15
	KB20002759	PUSH BUTTON PR4-13A00T
	KB20003296	TACT BUTTON MOLD QZ3-08A00T
	OM10001284	ORNAMENTAL SIDE BOARD 4TR-2797#3
	OM10001983	DIFFUSSOR MOLD QZ4-13A00T
	OM10001995	DIFFUSSOR MOLD QZ4-11A00T
	DD40000095	LED SEL1124R
	OM70000065	PUSH BUTTON CONNECTOR 4TTL-15
	SN00000179	BUTTON SPRING 4TR-1988A#2 10F
	AG00000524	REMOTE CONTROL HANDSET RR-930
	AU00001456	TOP COVER 3TUV-6#9
	KB10001813	KNOB 11F 4TSA-7#2
	KB10001886	KNOB W/LED QT4-08A00T 43F
	FE00000067	FELT 4TR-1083B#1 22F
	FE00000432	FELT 4TR-1083B#5 58F
	OM70000466	PUSH BUTTON CONNECTOR 4TR-3114
	SR00000882	UPPER COVER SPACER 4TR-2418
	SR00000961	RUBBER CAP 4TTV-8 6.6MM
	PL00001063	STYROL SIDE MOULDING 3TUV-7A#2
	TN10005080	INSIDE CARTON RSP-980 4TR-3214

## 5.1 CH DOLBY PRO P.C.B.

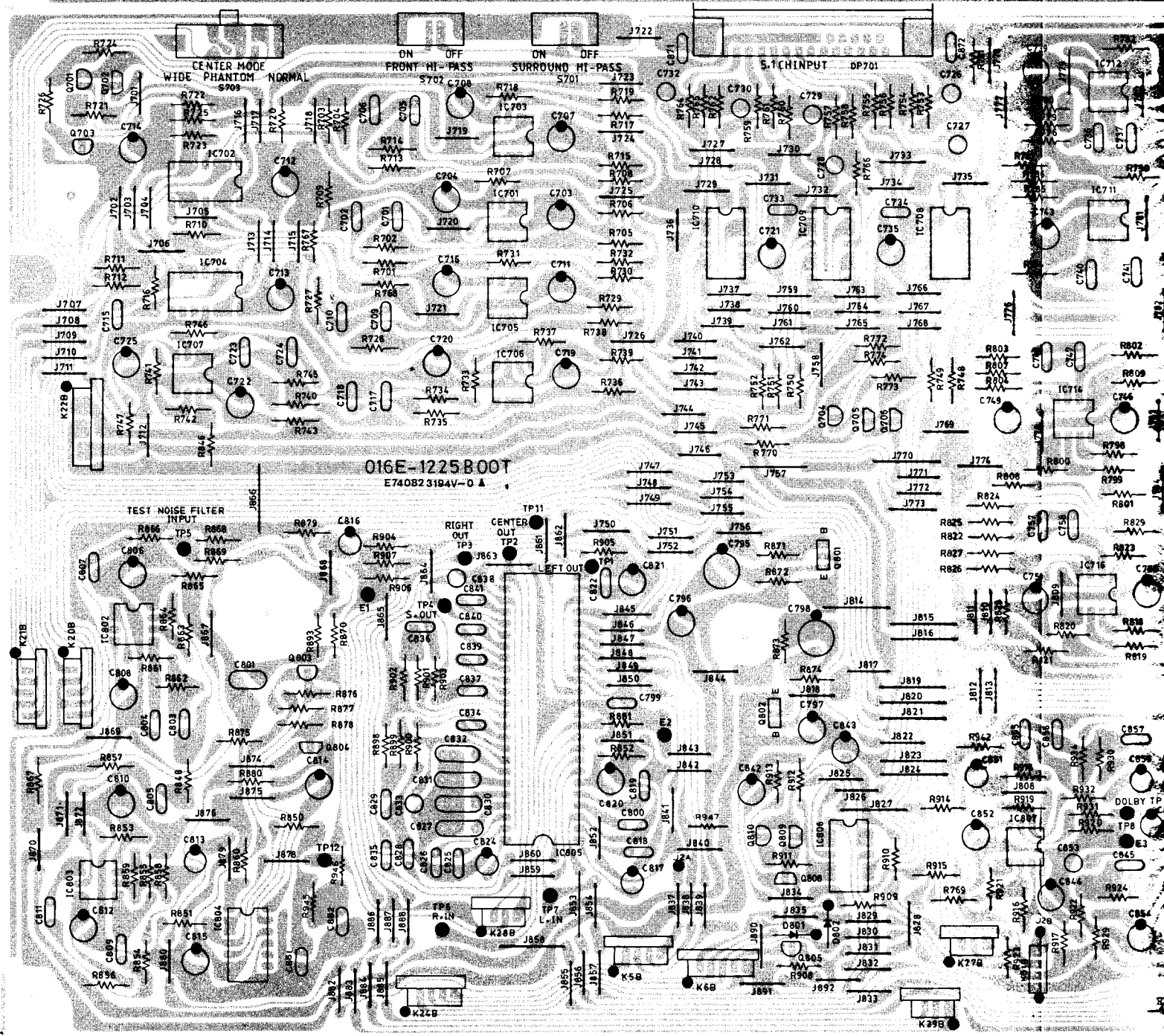



# REMOTE KEY BOARD P.C.B

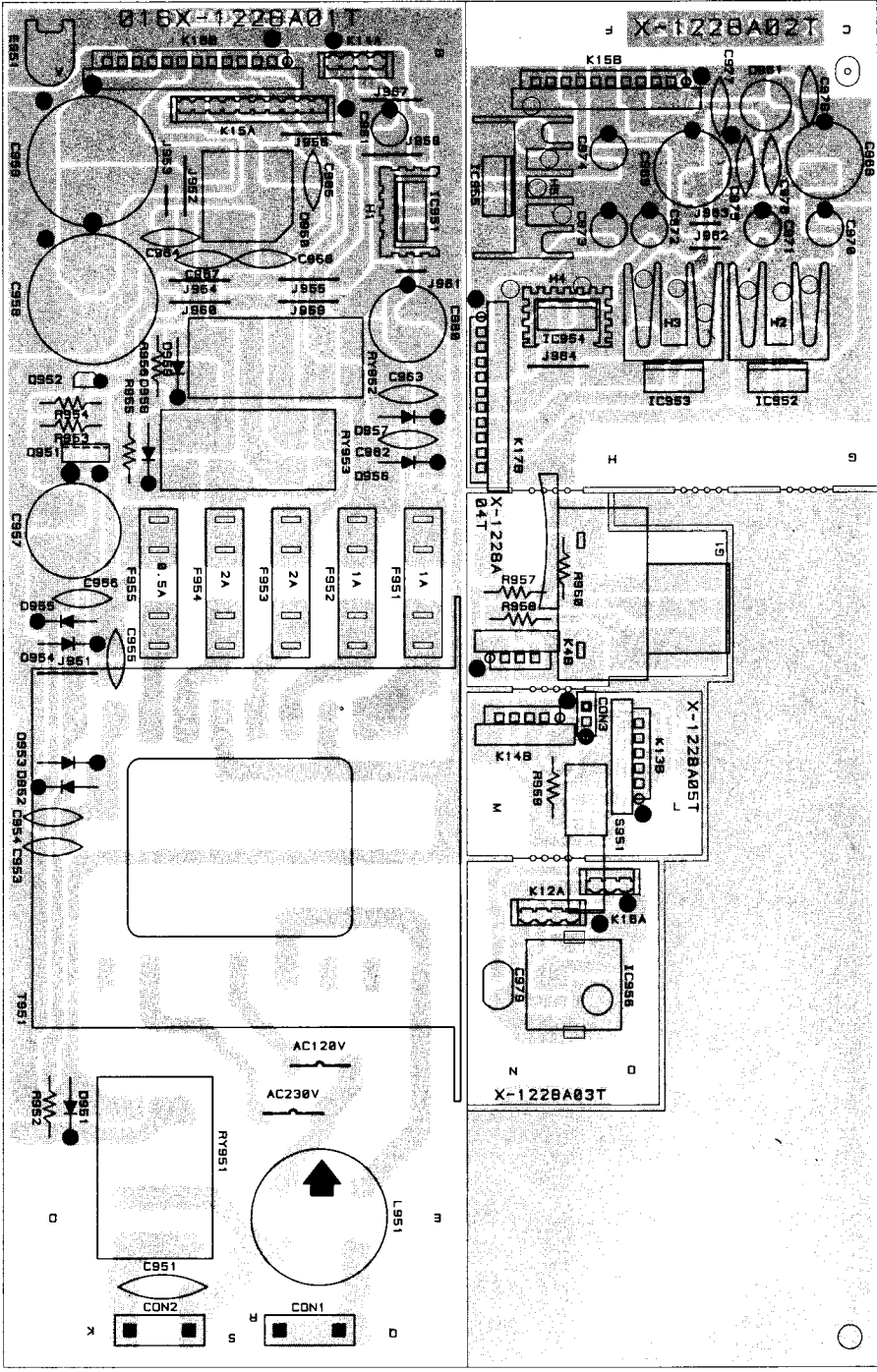
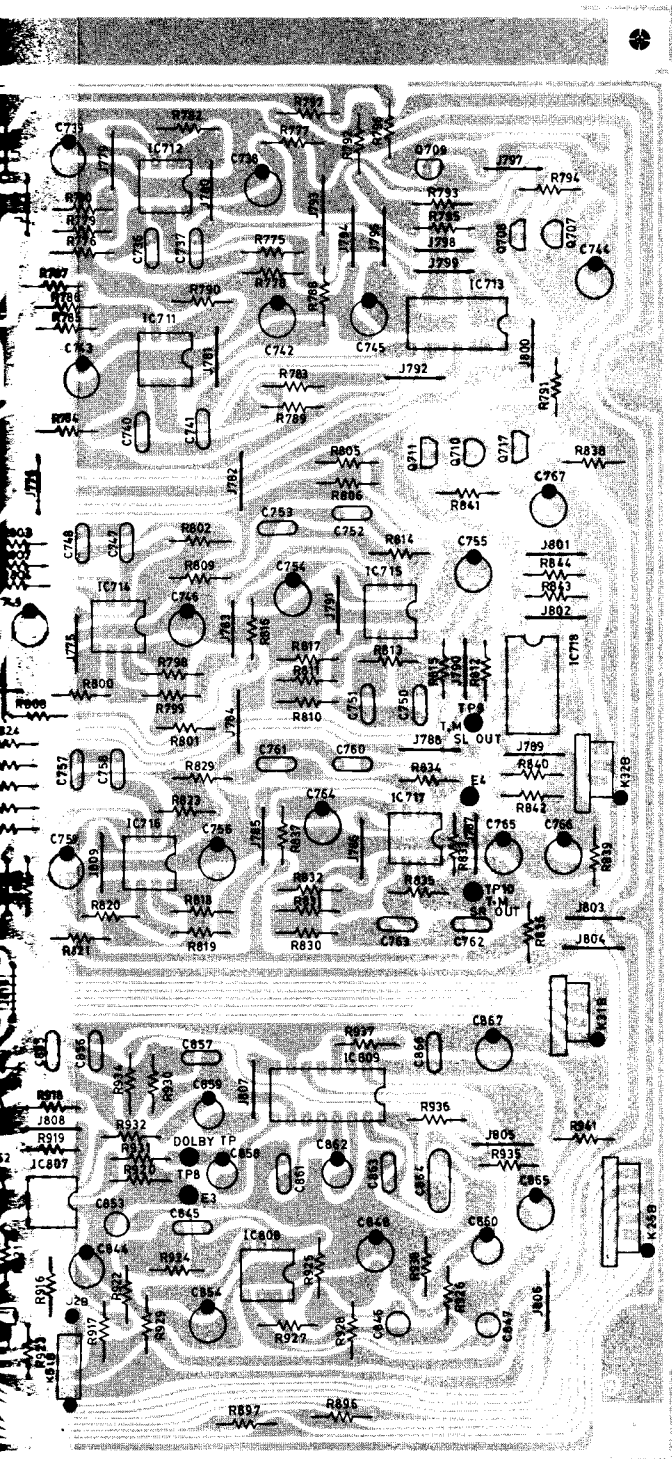

## S VIDEO P.C.B.

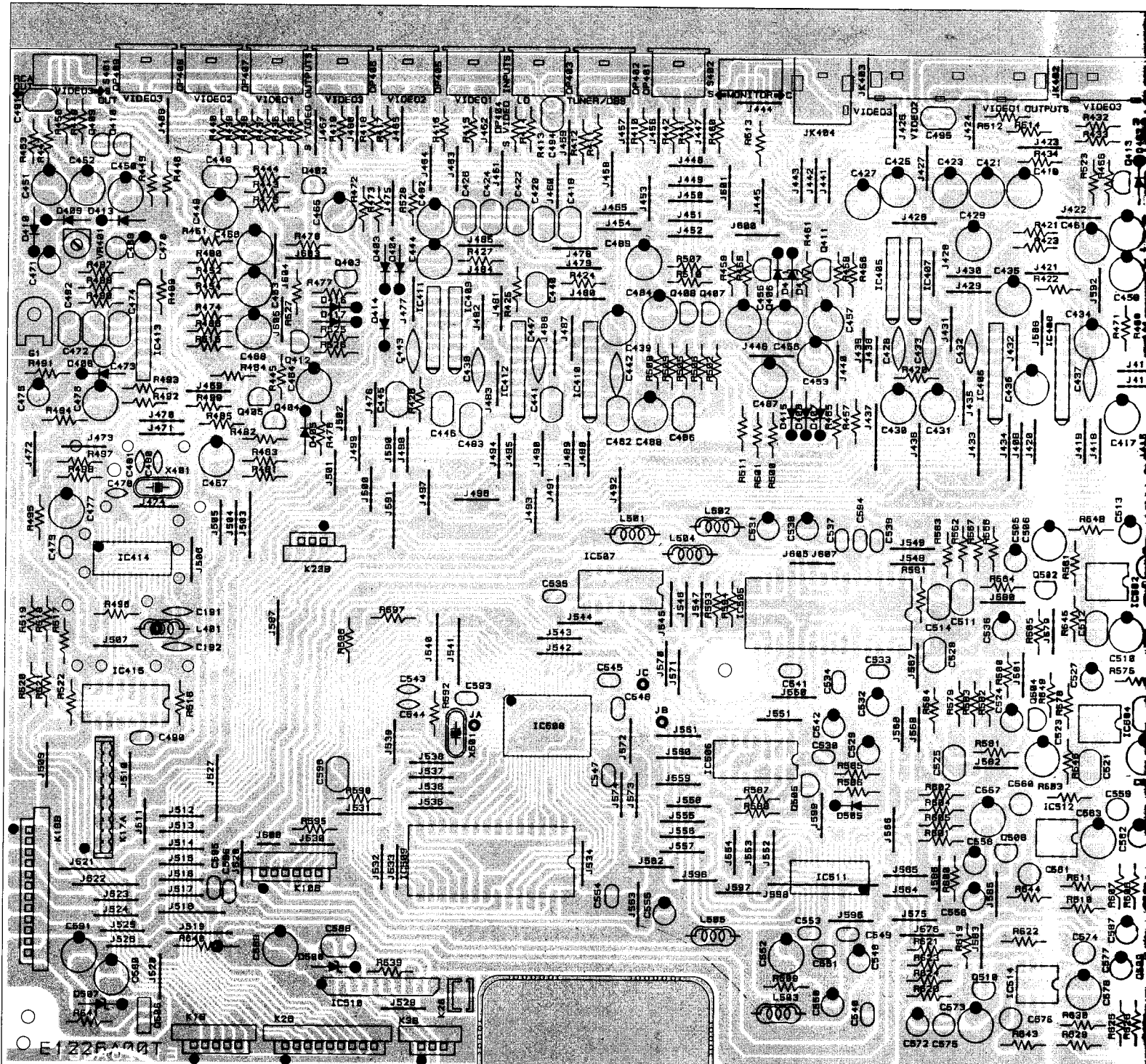

# POWER P.C.B.

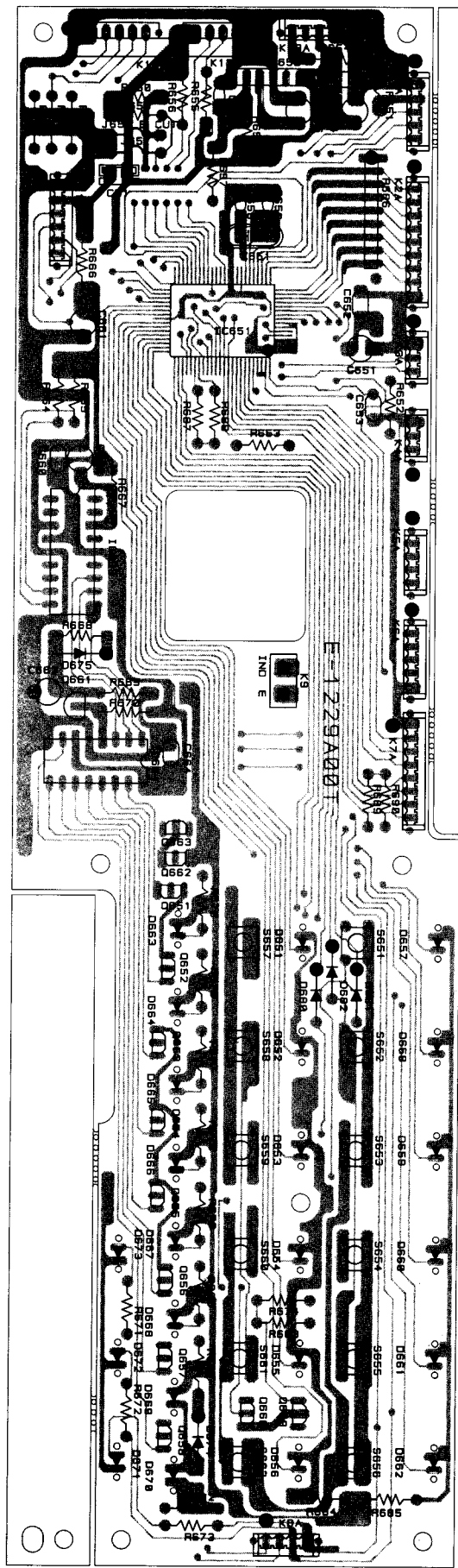
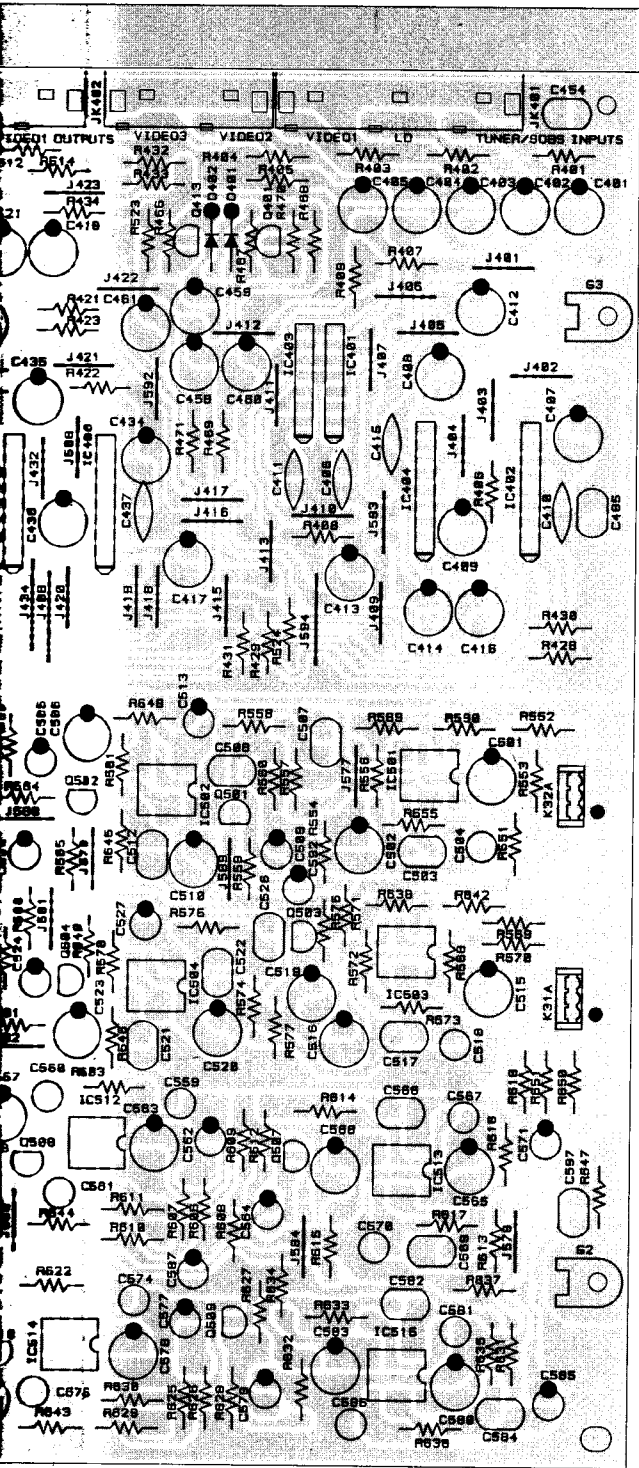

## AUDIO P.C.B.

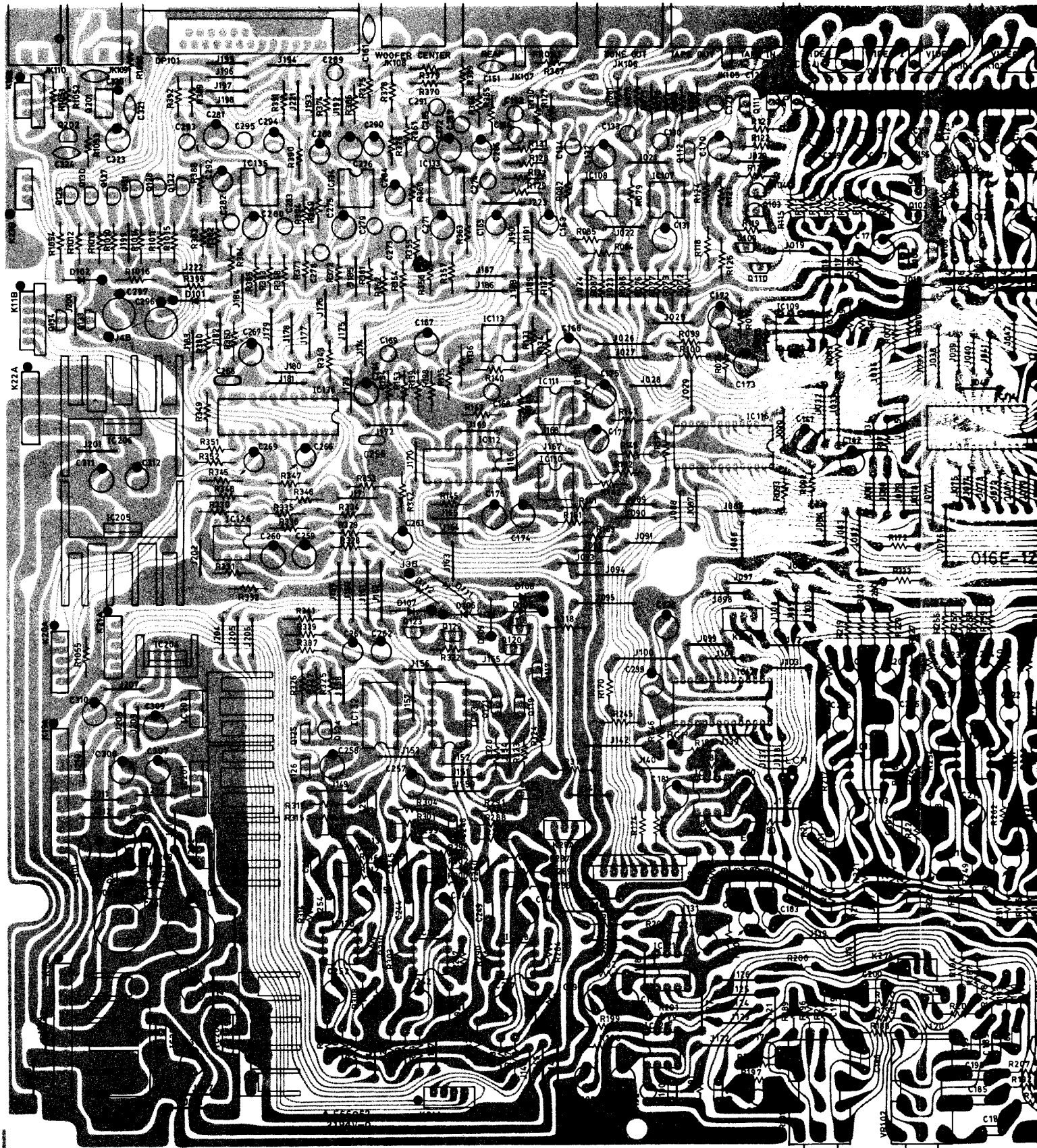

# 5.1 CH MUTING BAL CK CONTROL P.C.B.

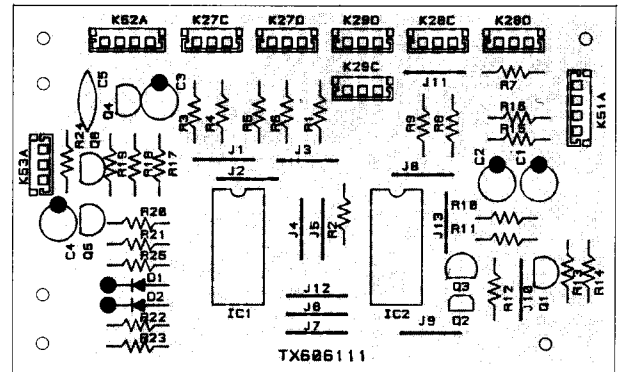
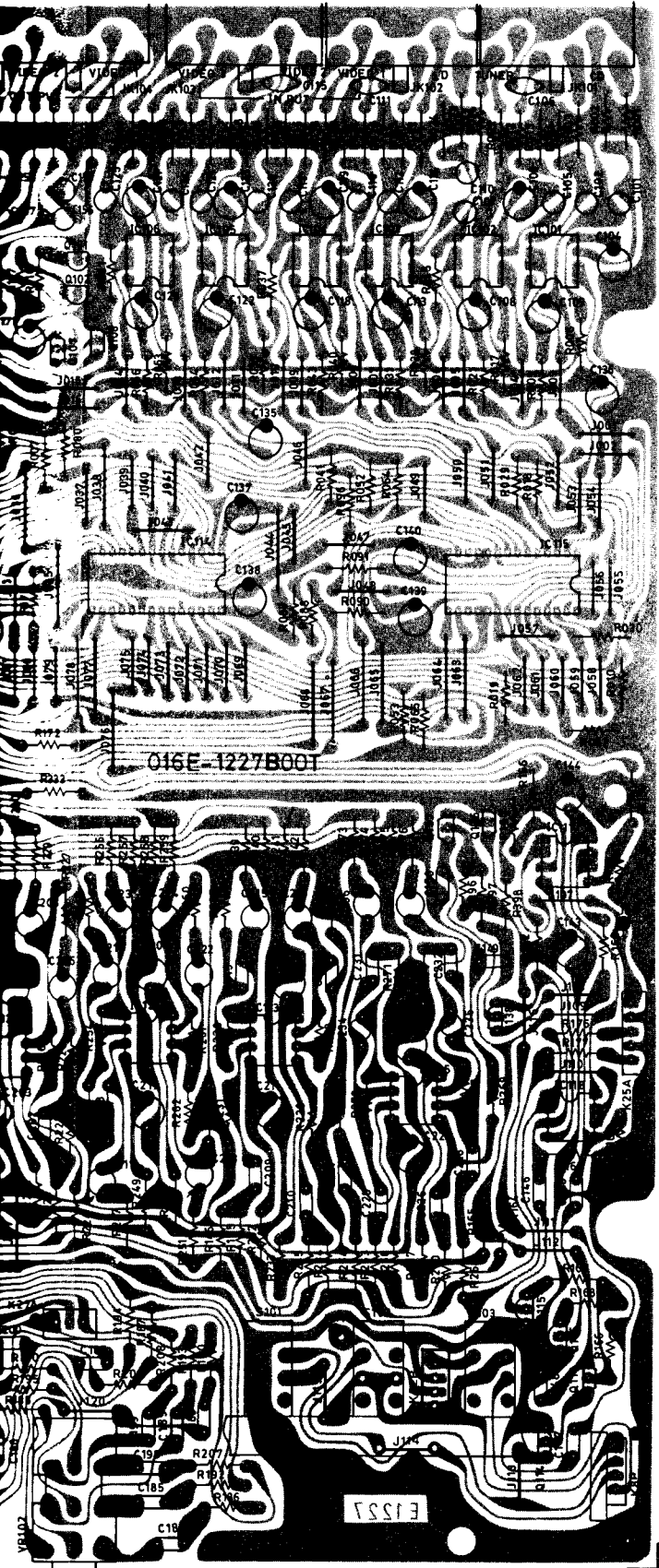

# Wiring Diagram

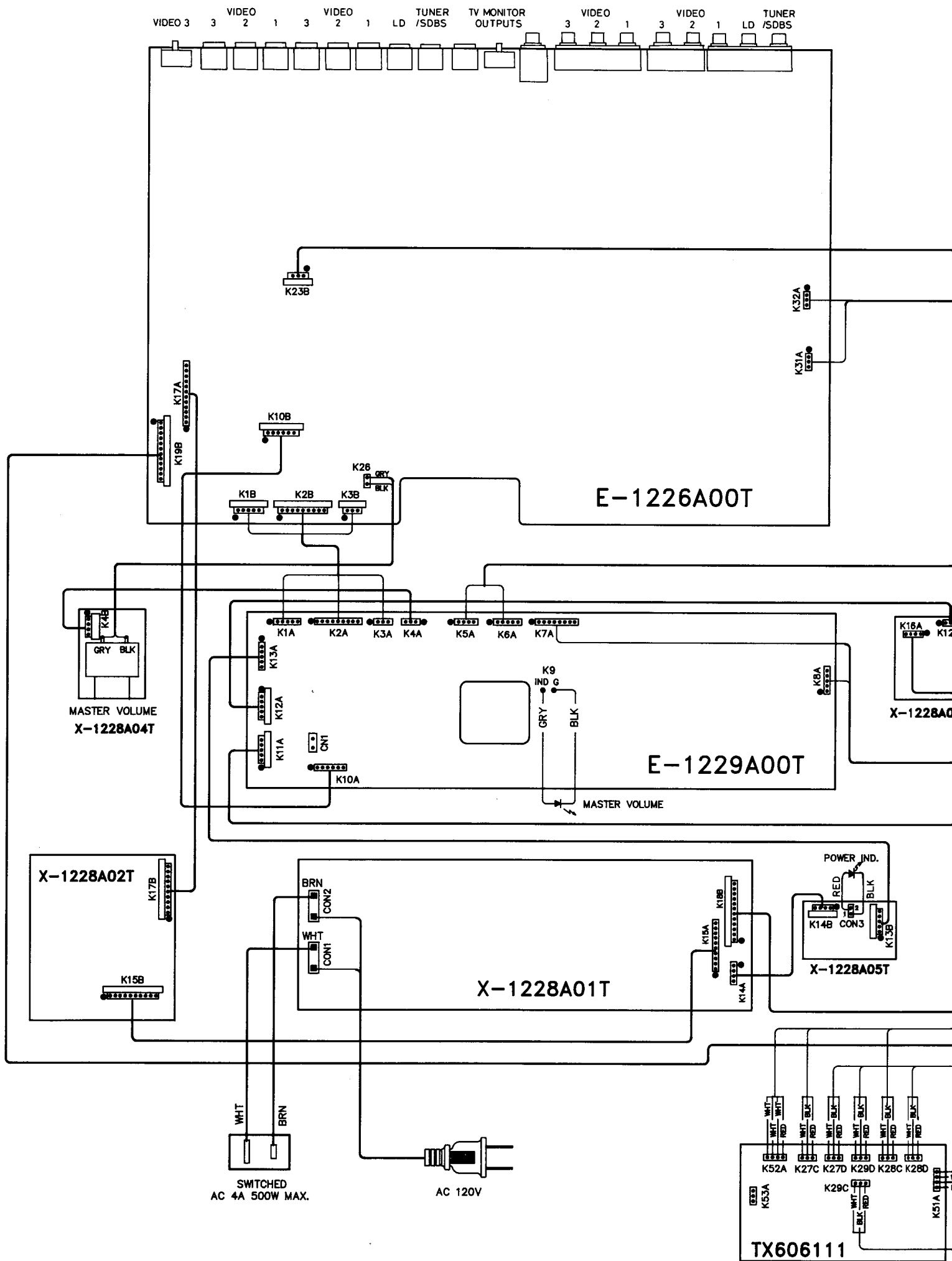

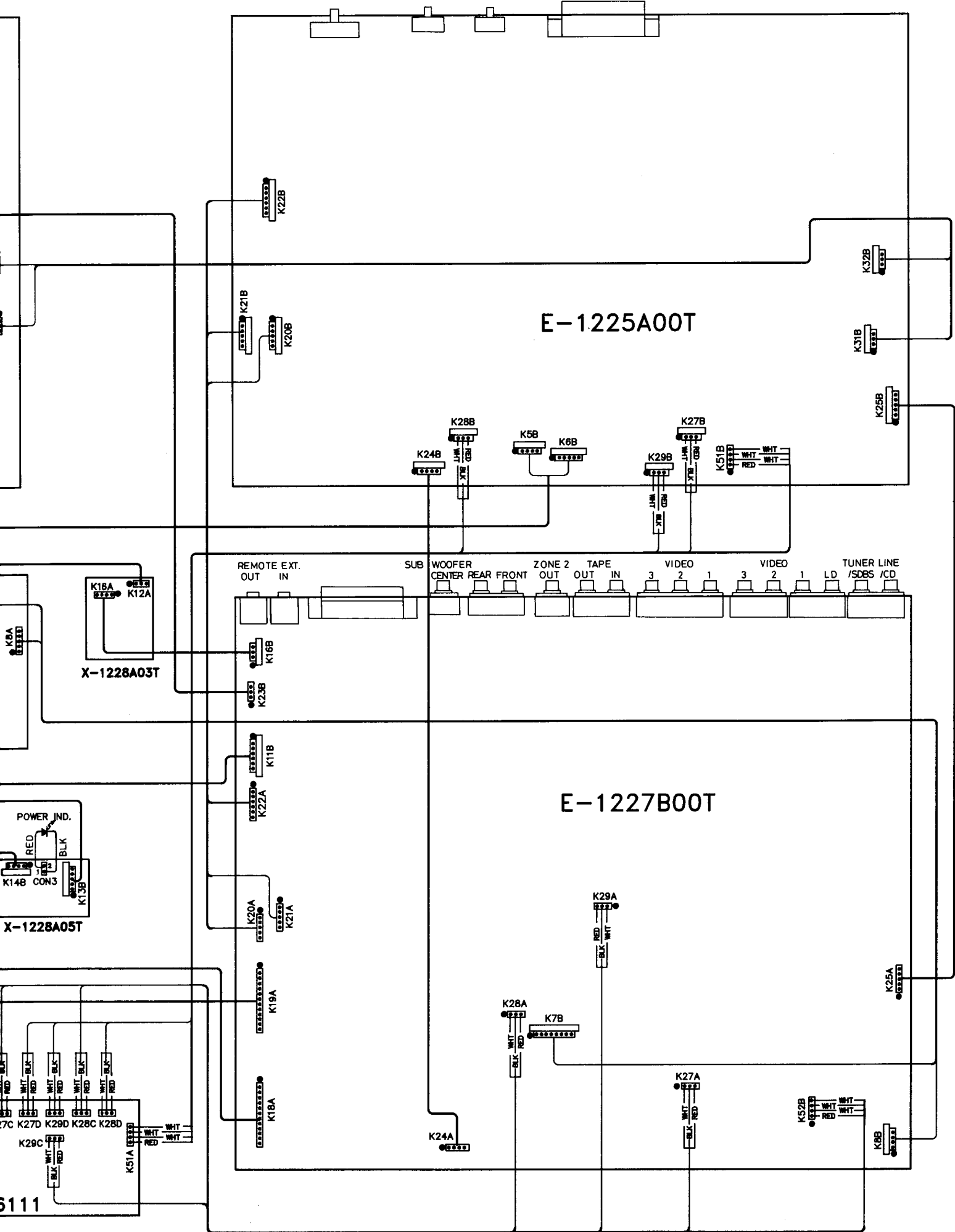

E-1225A00T

X-1228A03T

E-1227B00T

# FUNCTIONAL BLOCK DIAGRAM

ROTEL RSP-980

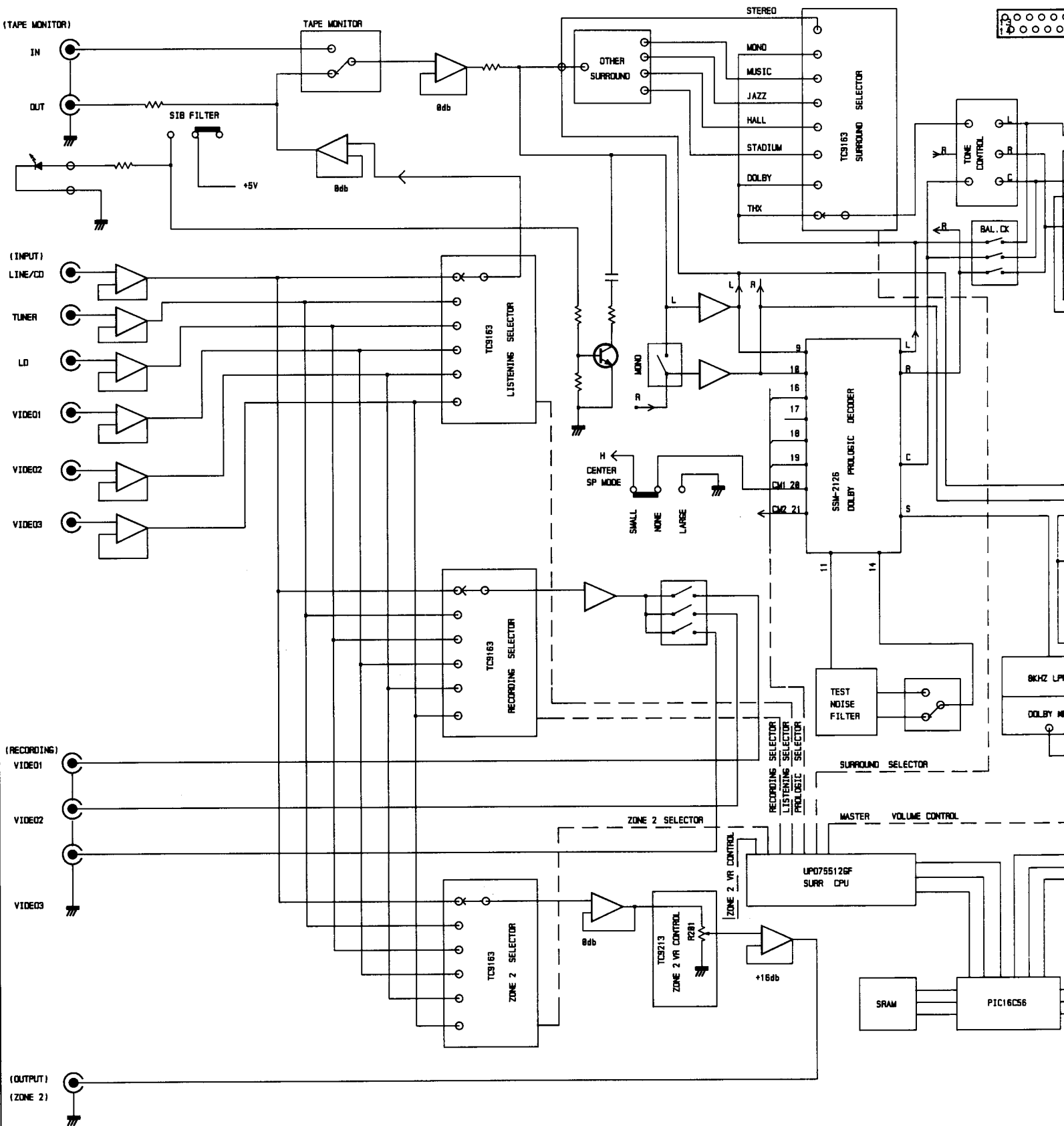



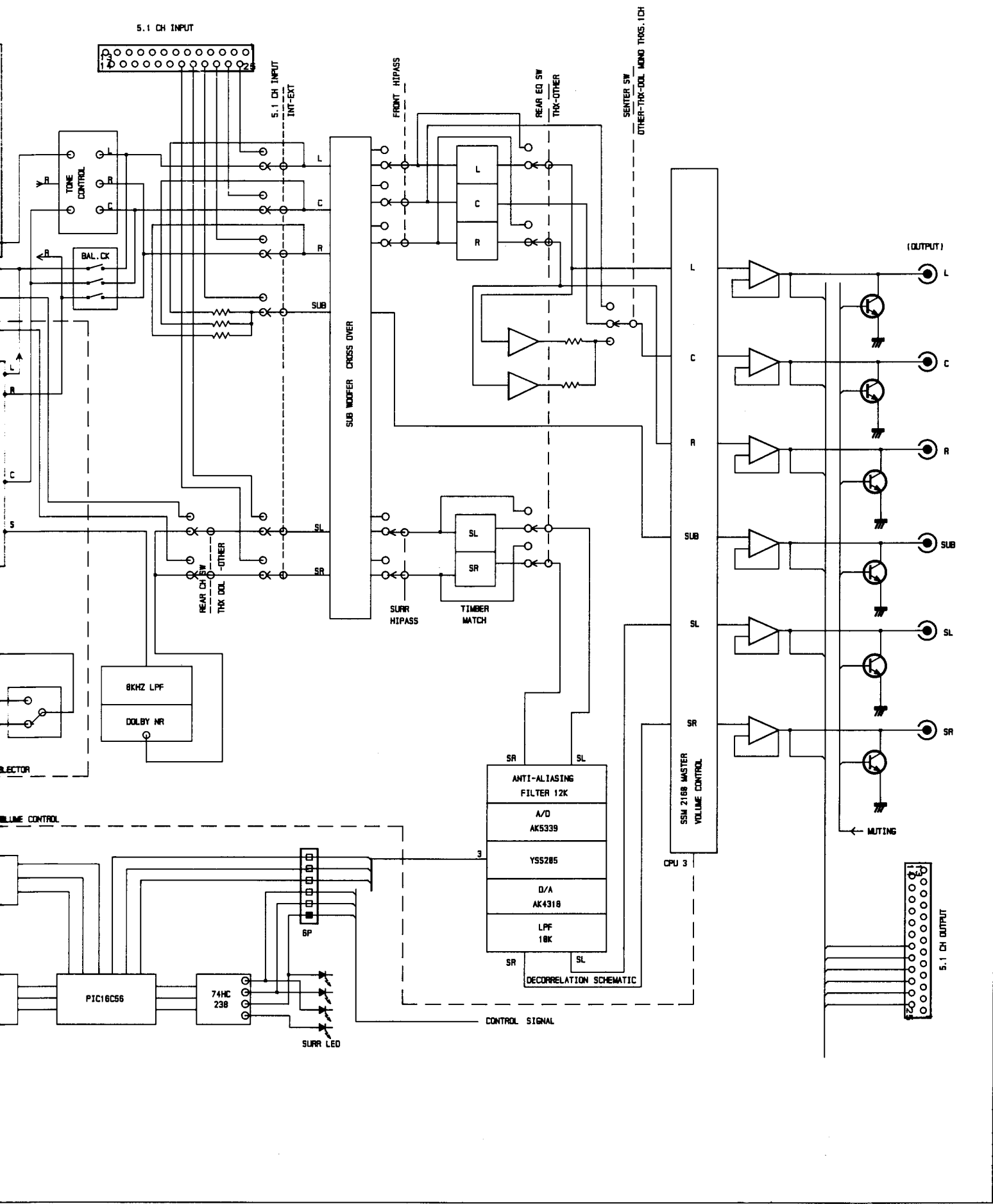

# SCHEMATIC DIAGRAM RSP-980 (2/8)

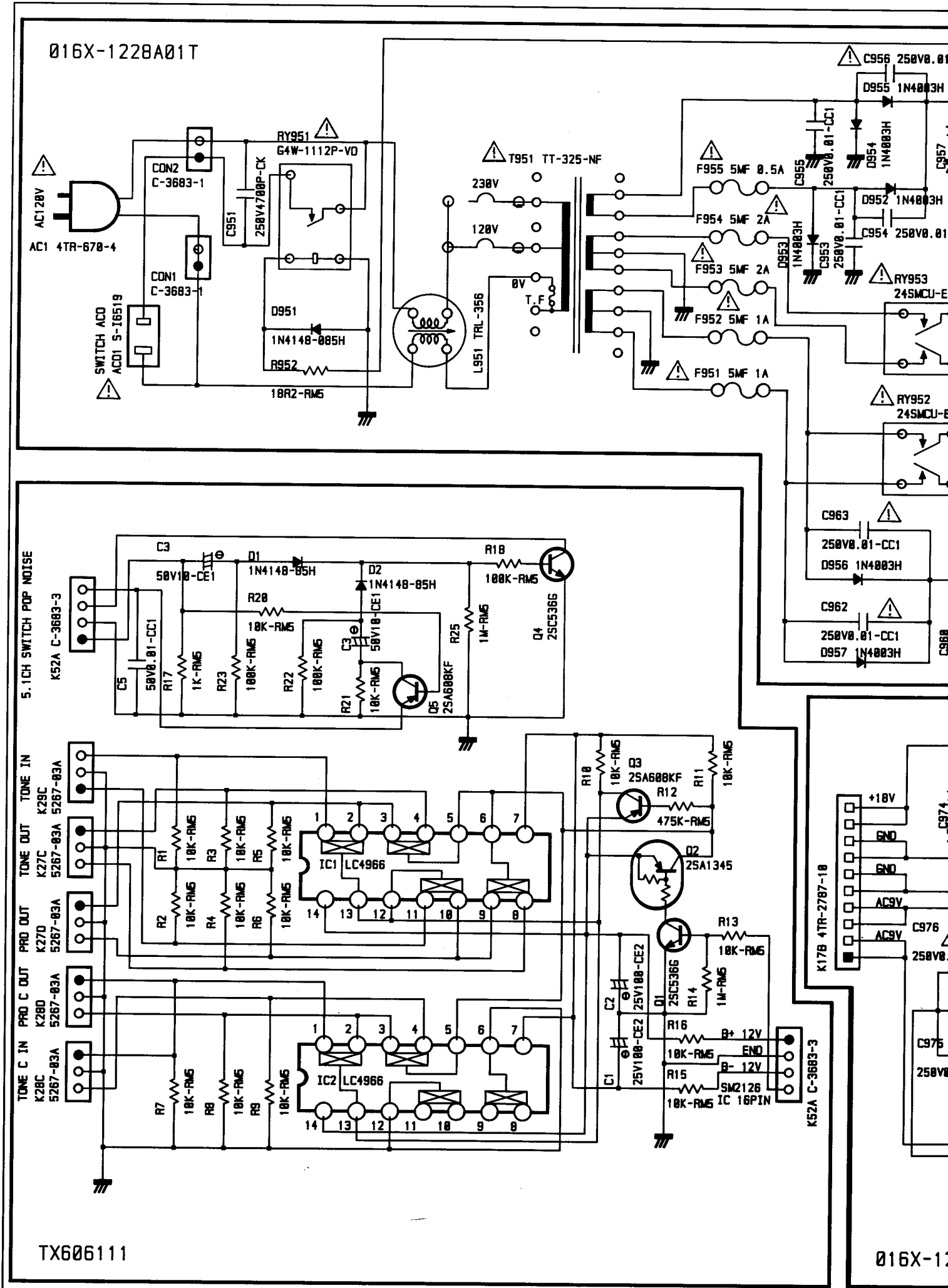

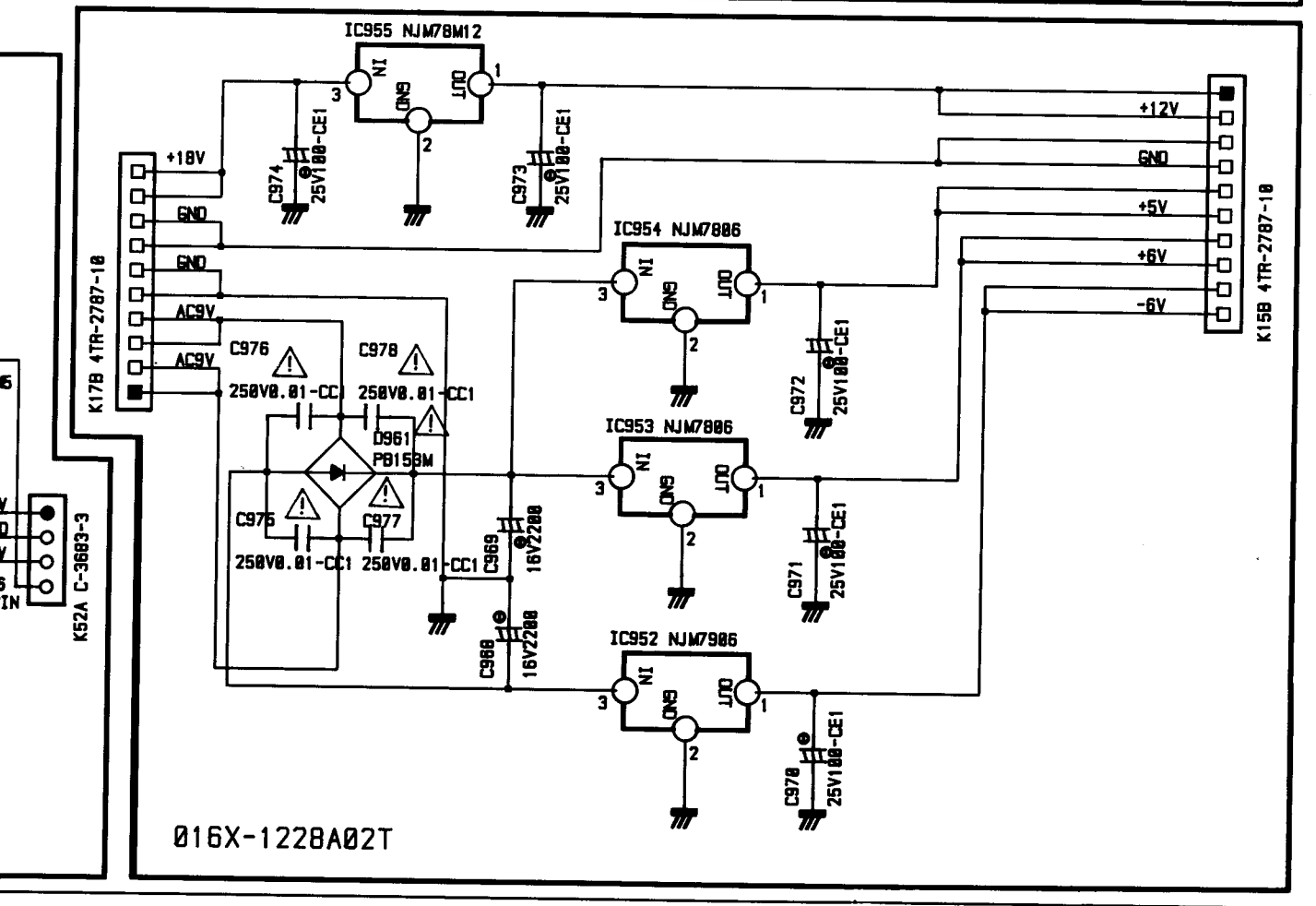
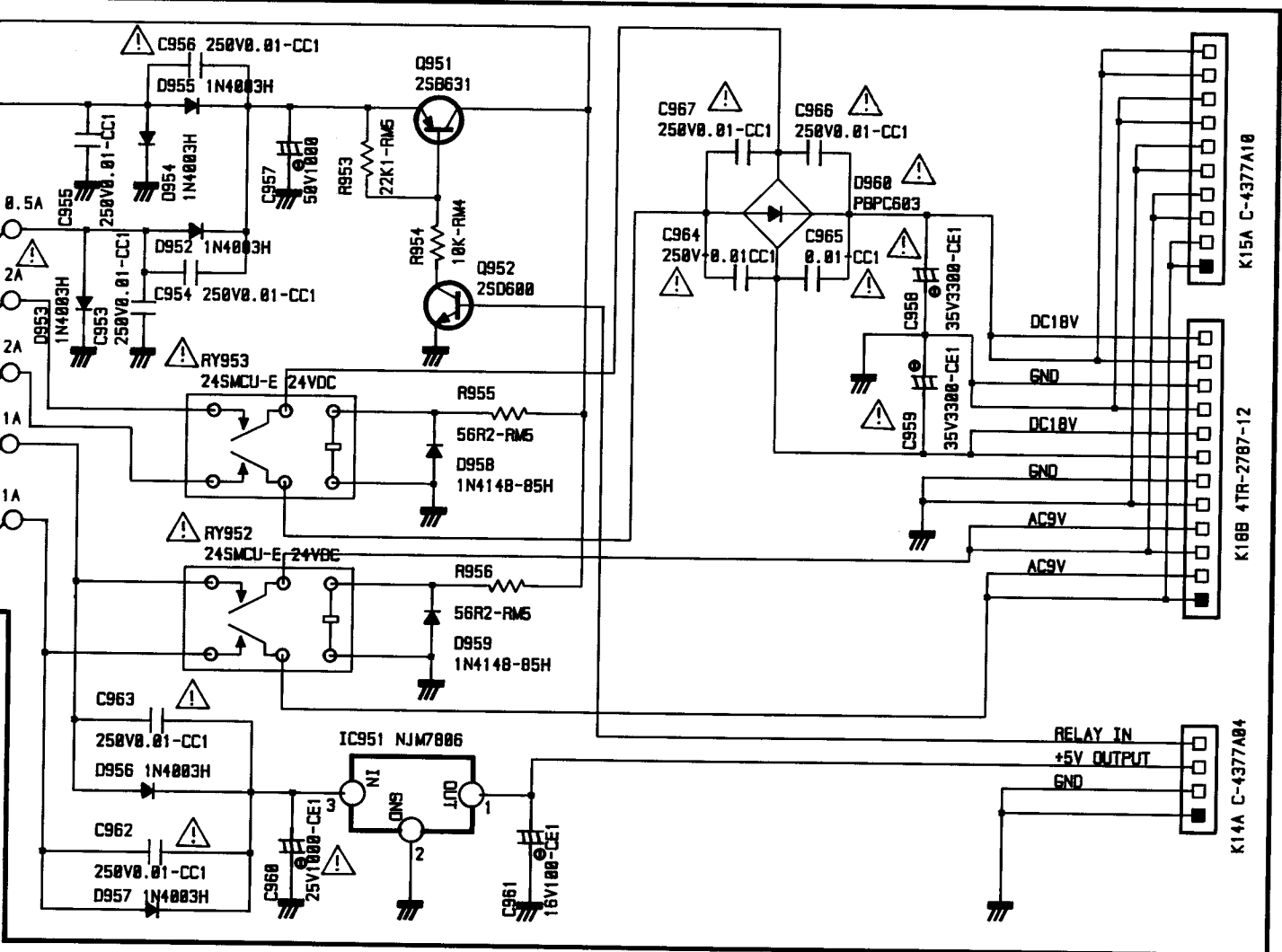

016X-1228A02T

# SCHEMATIC DIAGRAM RSP-980 (3/8)

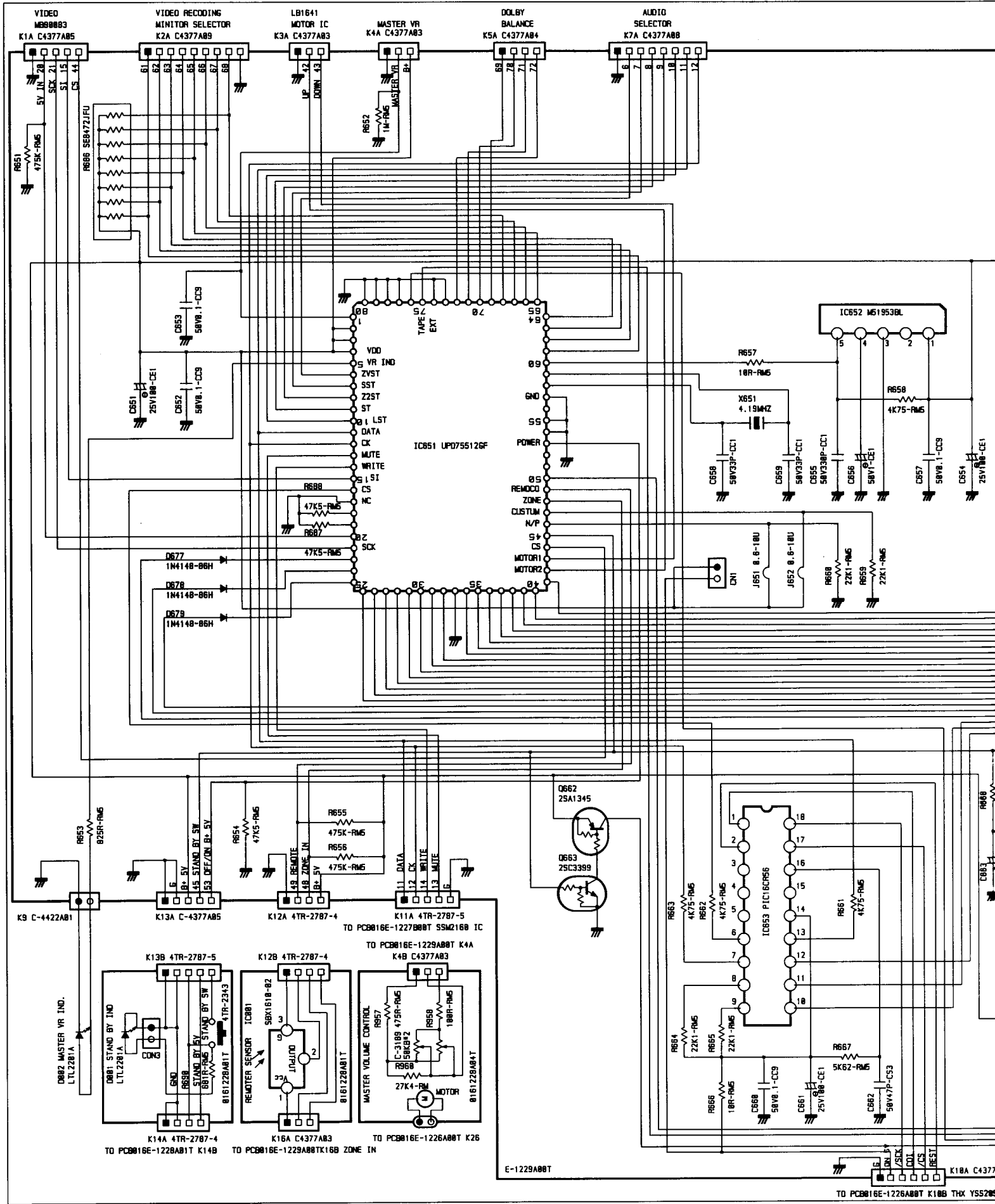

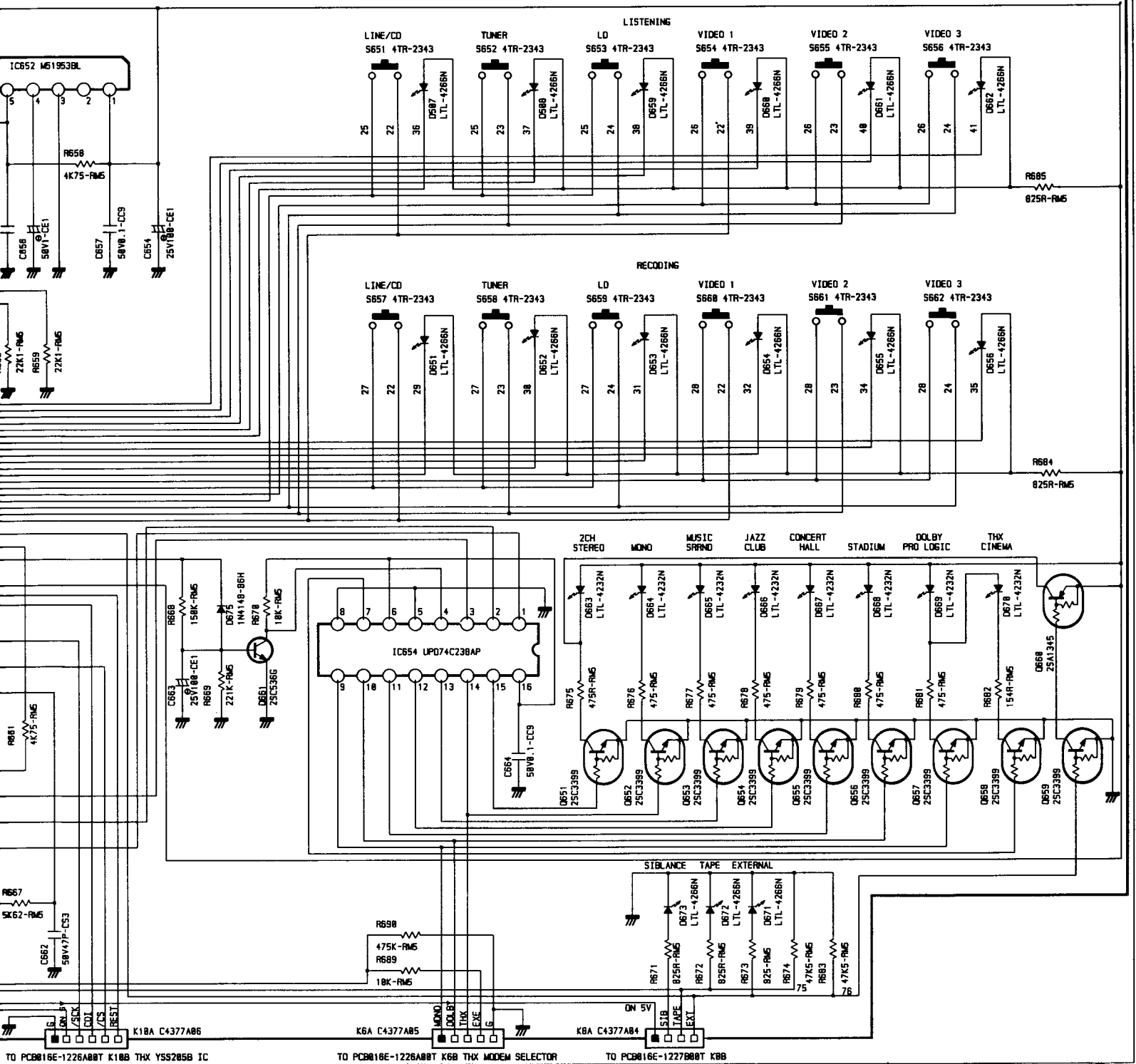

**SCHEMATIC DIAGRAM RSP-980 (4/8)**

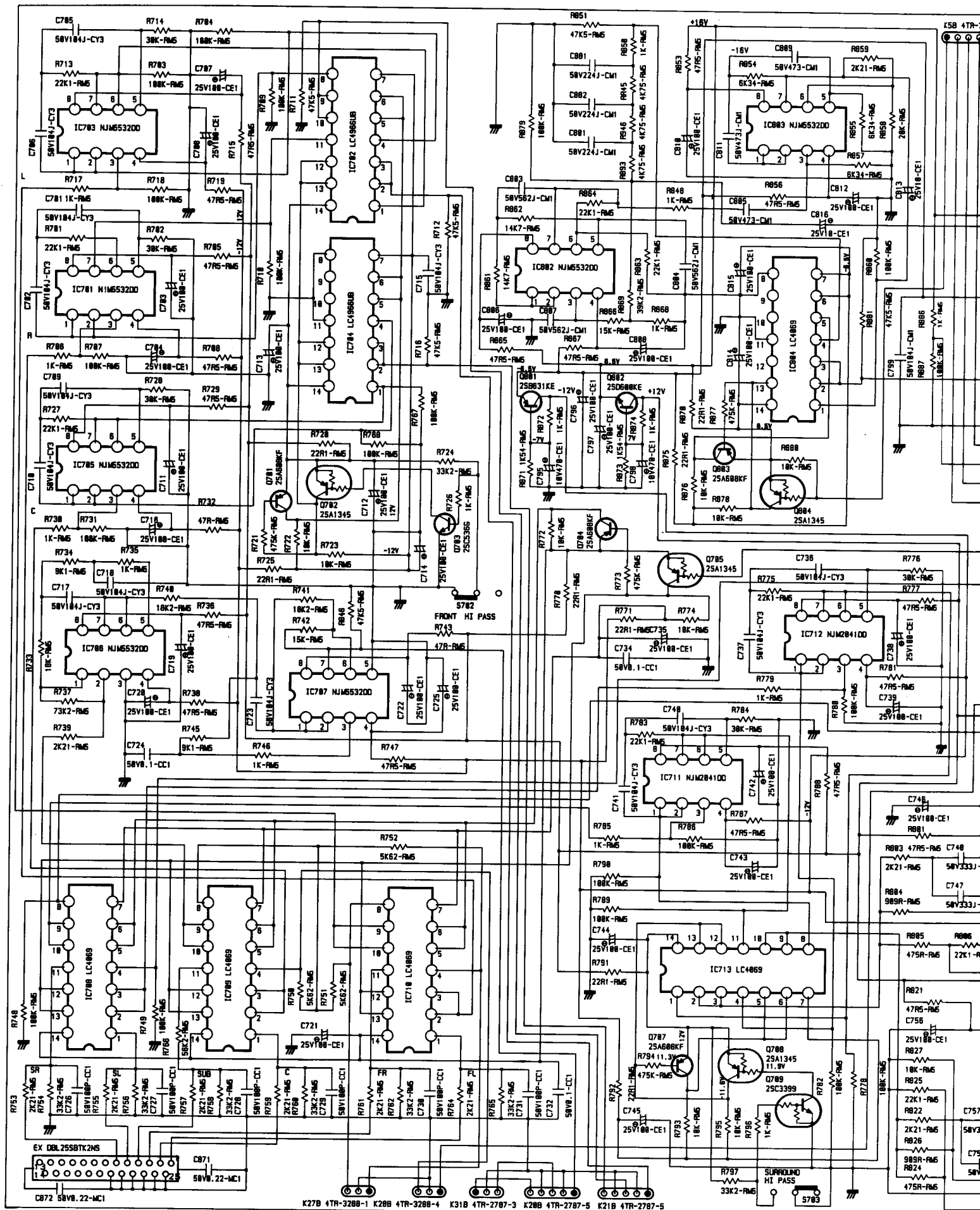

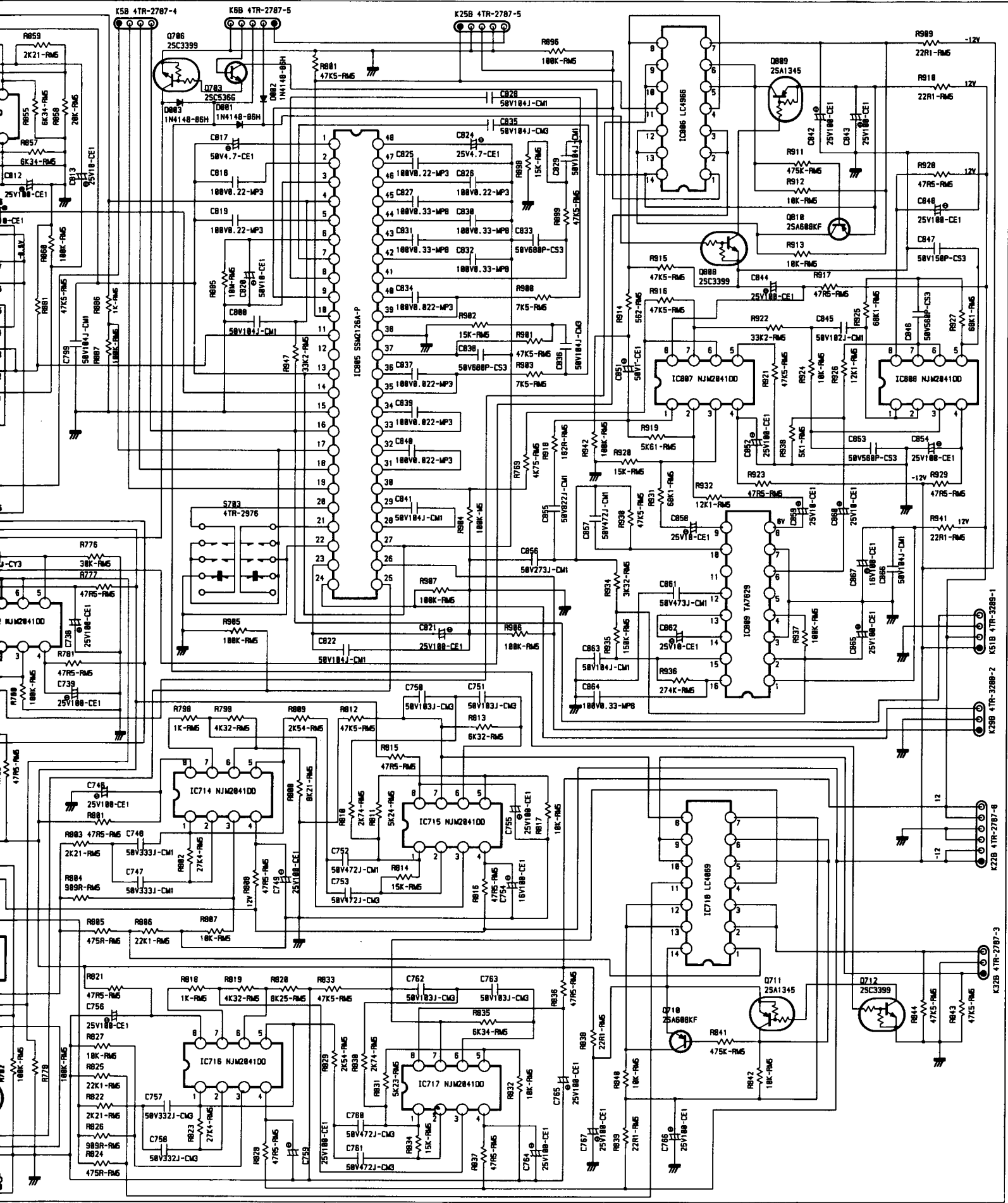

# SCHEMATIC DIAGRAM RSP-980 (5/8)

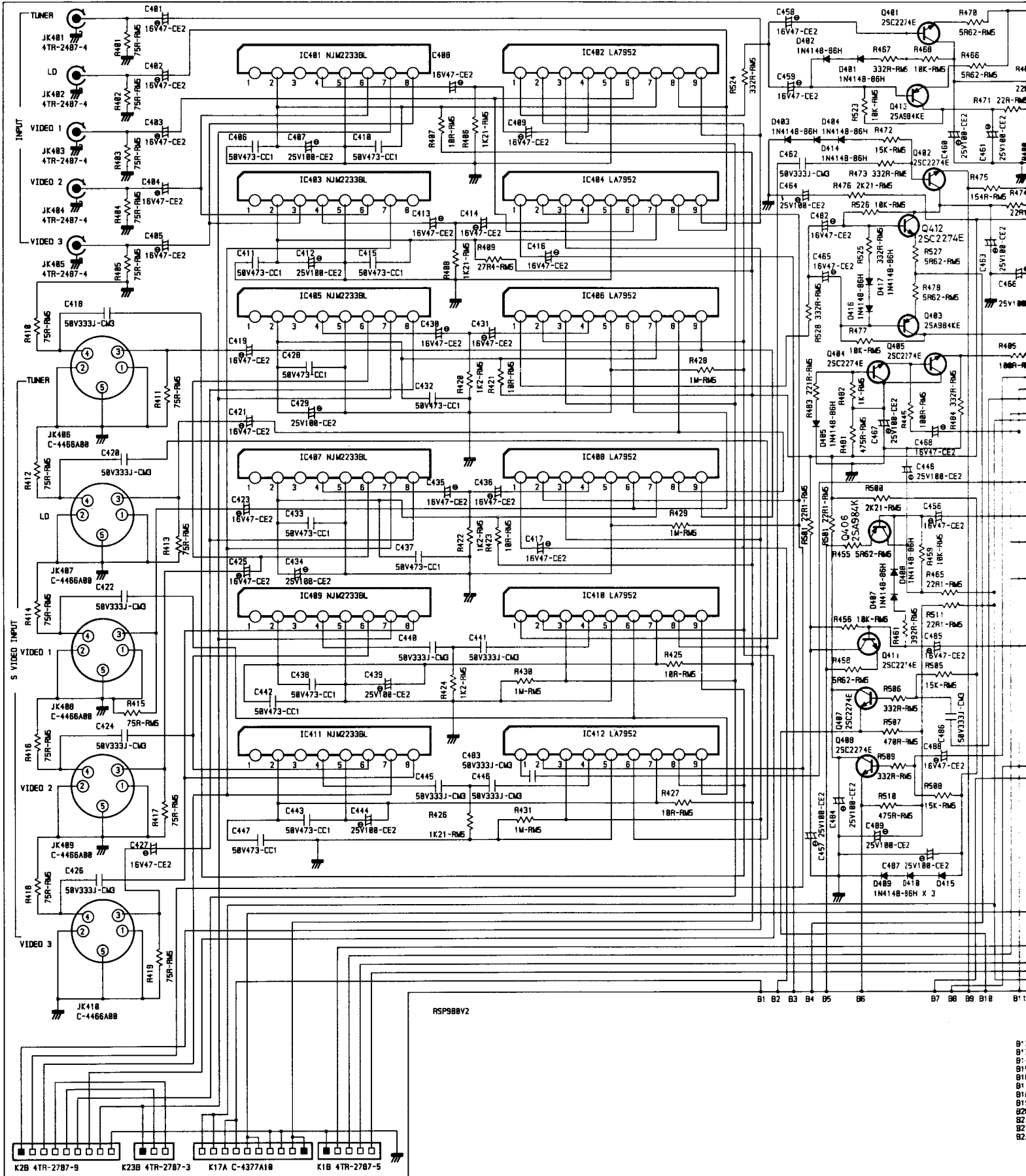



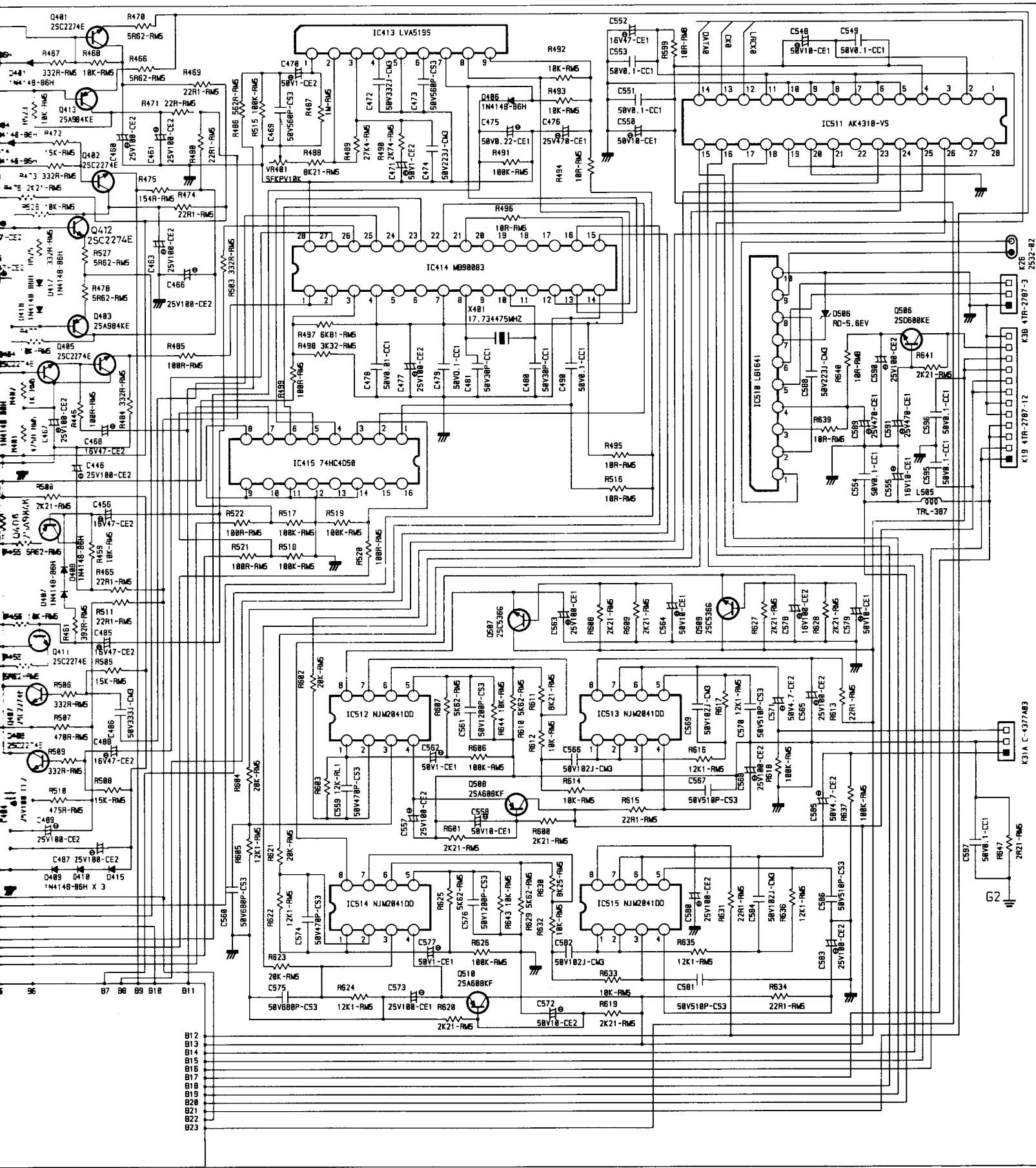

# SCHEMATIC DIAGRAM RSP-980 (6/8)

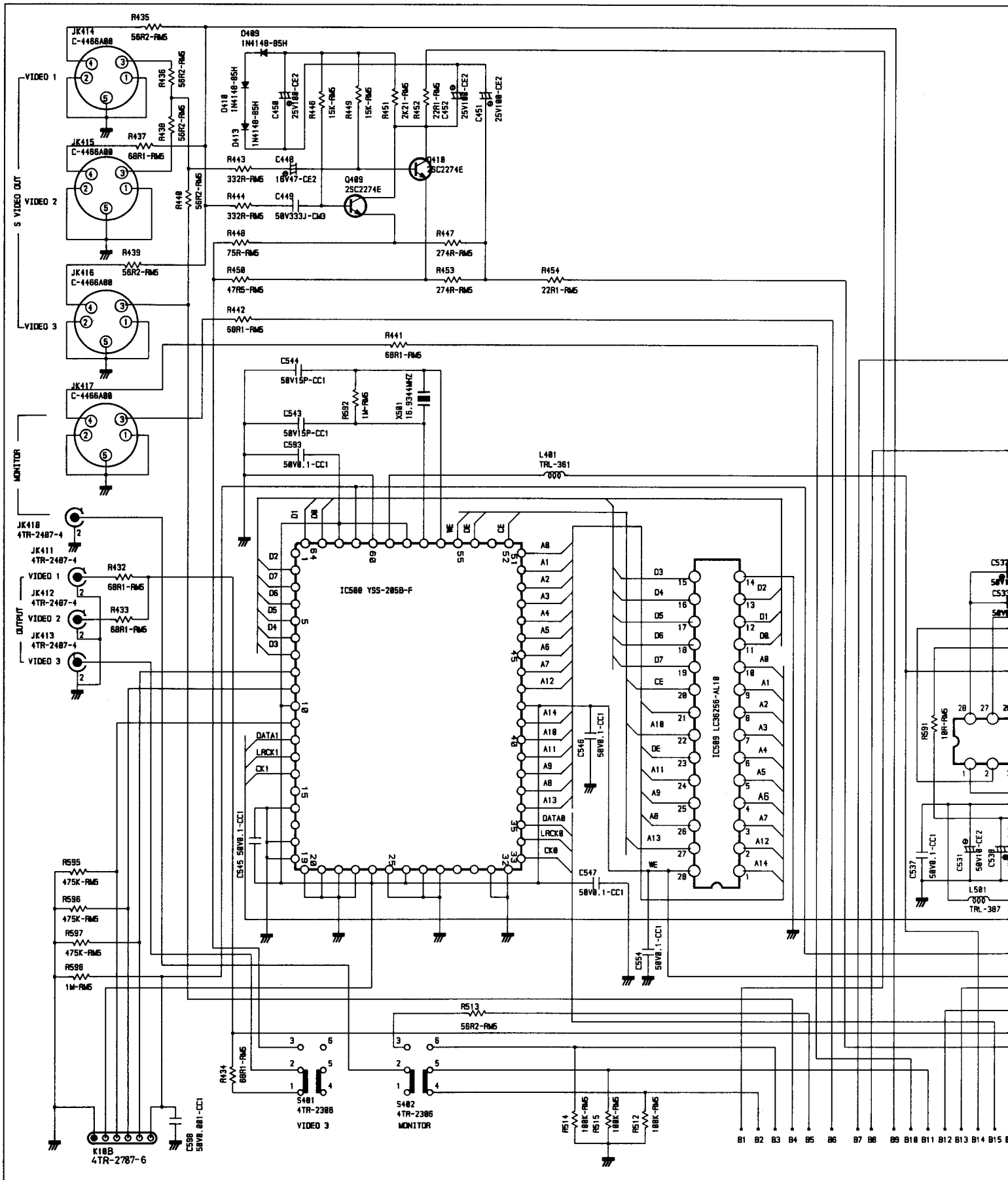

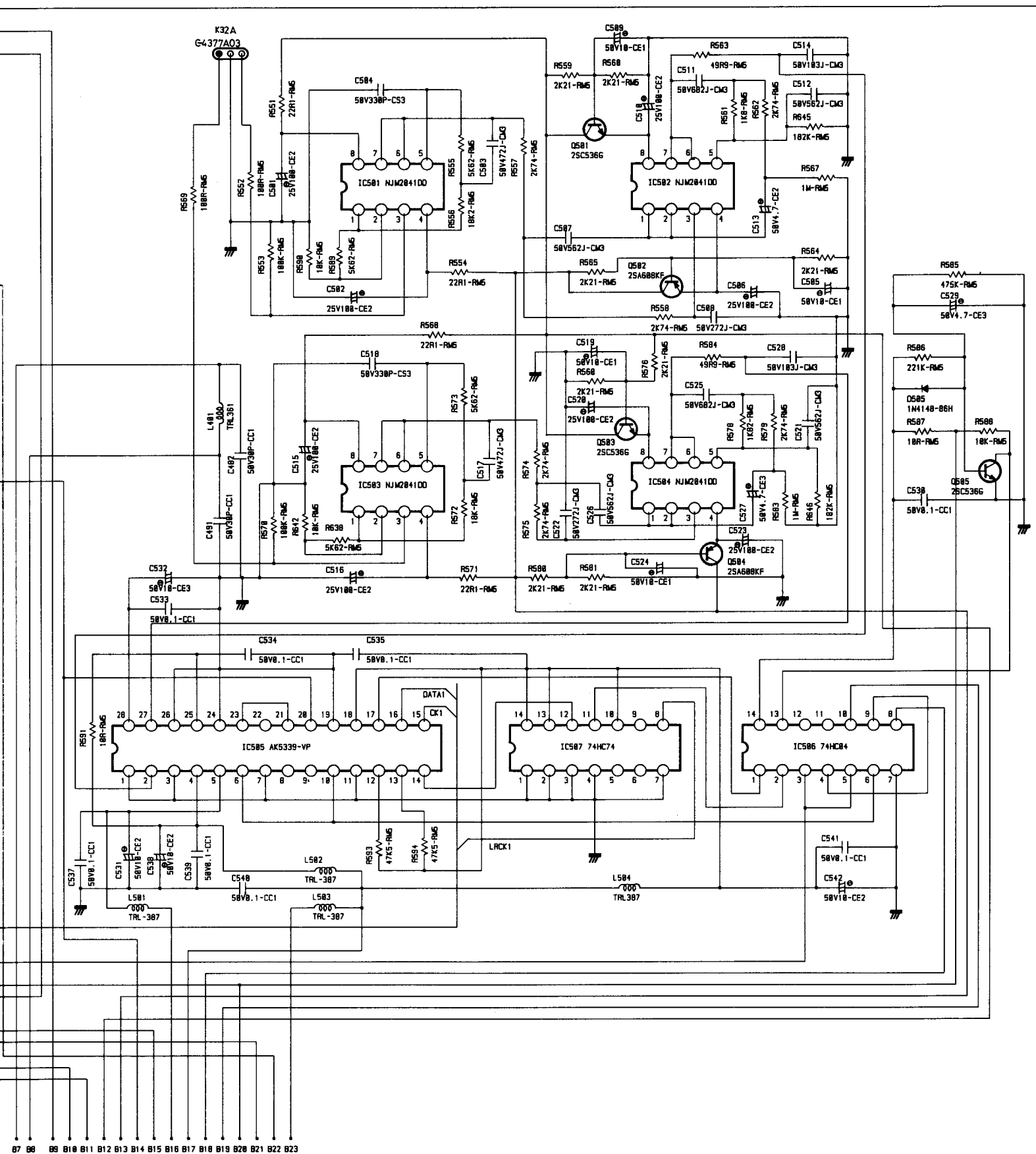

87 88 89 B10 B11 B12 B13 B14 B15 B16 B17 B18 B19 B20 B21 B22 B23

# SCHEMATIC DIAGRAM RSP-980 (7/8)

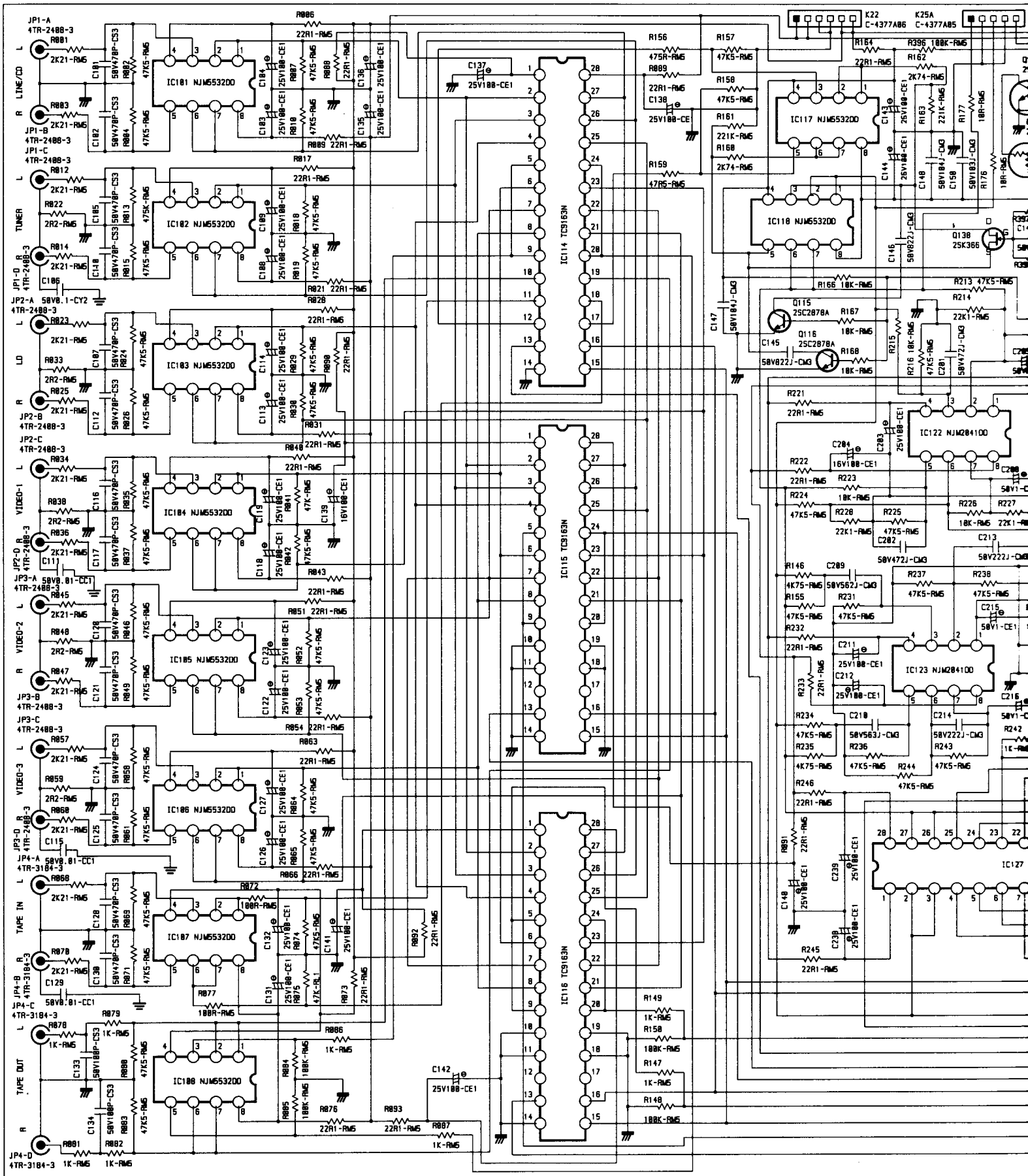

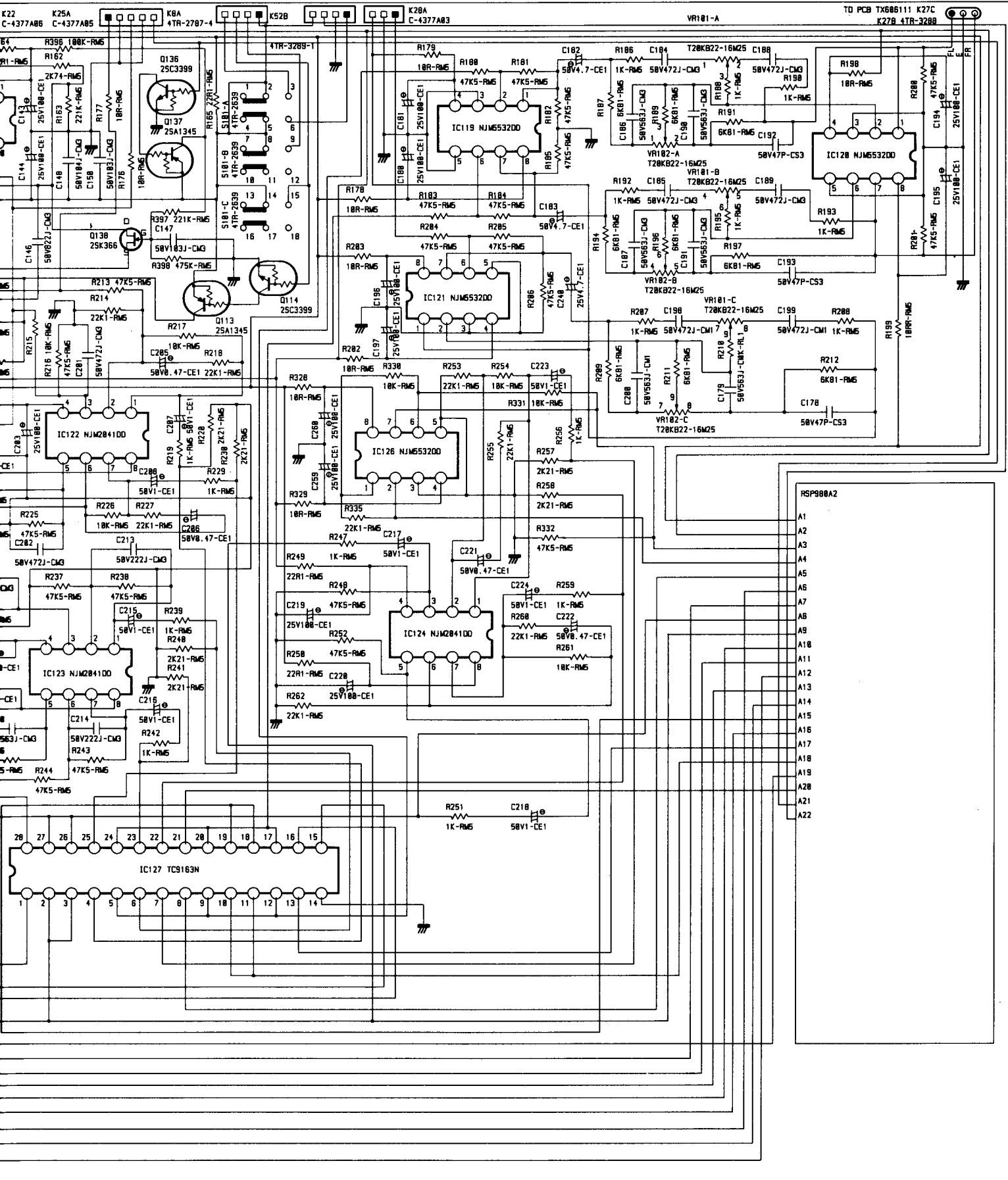

# SCHEMATIC DIAGRAM RSP-980 (8/8)

