

Quality Uncompromised

ROTEL[®]

Technical Manual

SURROUND SOUND RECEIVER **RSX-1057**

Table of Contents

Specification.....	1	PCB Assembly.....	18~24
Parts List.....	2~13	Schematic Diagram	25~39
Adjustment.....	14~16		
Wiring.....	17		

Specifications

Audio

Continuous Amplifier Power

(five channels driven)

75 watts/ch (20-20k Hz, <0.05% THD, 8 ohms)

Continuous Amplifier Power

(two channels driven)

100 watts/ch (1kHz, <1.0% THD, 8 ohms, DIN)

Total Harmonic Distortion

<0.09%

Intermodulation Distortion (60 Hz :7 kHz)

<0.05%

Frequency Response

10 Hz – 120 kHz, ±3dB (analog bypass)

10 Hz – 95 kHz, ±3dB (digital input)

Signal to Noise Ratio (IHF A-weighted)

95dB (analog bypass)

92dB (Dolby Digital, dts) 0dBFS

Input Sensitivity/Impedance

Line Level: 200 mV/100K ohms

Preamp Output Level/Output Impedance

1.0 V / 1K ohms

Contour (LF/HF)

±6dB at 50 Hz/15 kHz

Decodable Digital Input Signals

Dolby Digital, Dolby Digital EX, DTS, DTS-ES, DTS 96/24, LPCM (up to 192K), HDCD, MP3, MPEG Multichannel

Video

Frequency Response

3 Hz – 10 MHz, ± 3dB (Digital Input)

3 Hz – 100 MHz, ± 3dB (Component Video)

Signal to Noise Ratio

45dB

Input Impedance

75 ohms

Output Impedance

75 ohms

Output Level

1.0 volt

HDMI Input /Output

Version 1.1

FM Tuner

Usable Sensitivity

14.2dBf

Signal to Noise Ratio (at 65dBf)

70dBf

Harmonic Distortion (at 65dBf)

0.03%

Stereo Separation (1 kHz)

45dB

Output level

1 V

Antenna Input

75 ohms unbalanced

AM Tuner

Sensitivity

500 V/m

Signal to Noise Ratio

40dBf

Output level

500 mV

Antenna Input

Loop Antenna

General

Power Consumption:

450 watts

78 watts (idle)

8 watts (standby)

Power Requirements (AC)

120 volts, 60Hz (USA version)

230 volts, 50Hz (CE version)

Weight

17.2 Kg/37.8 lb.

Dimensions (W x H x D)

432 x 162 x 442 mm

17.01" x 6.38" x 17.40"

Front Panel Height

(feet removed/for rack mount)

150 mm / 5.91"

THE ROTEL CO., LTD.

SHINSEN-BLD. 4F 10-10 SHINSEN-CHO, SHIBUYA-KU,
TOKYO 150-0045, JAPAN

Serial. NO.
Beginning

Y-389A-0605/pdf

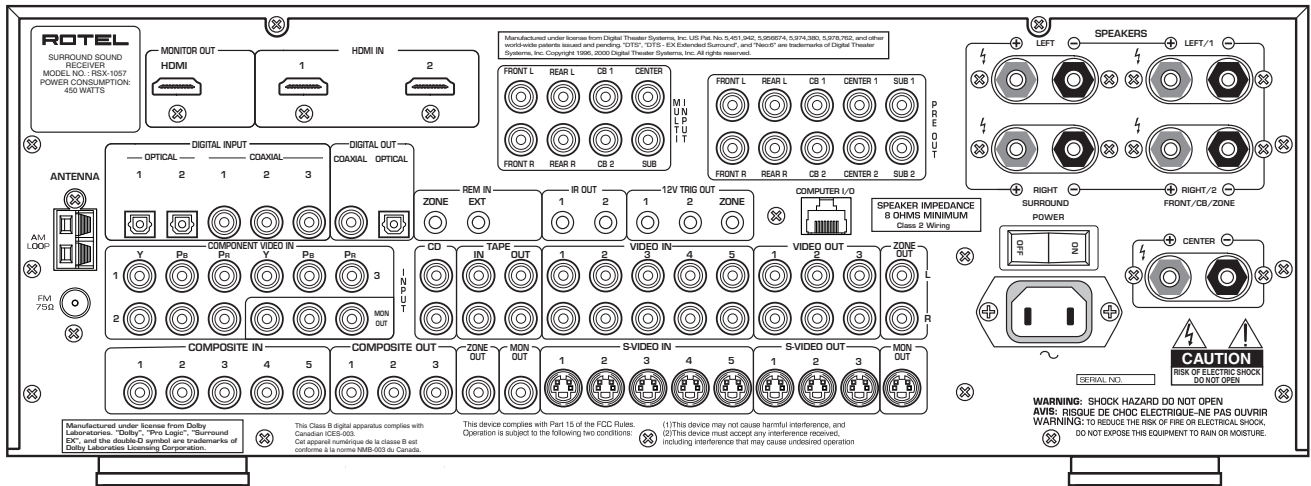
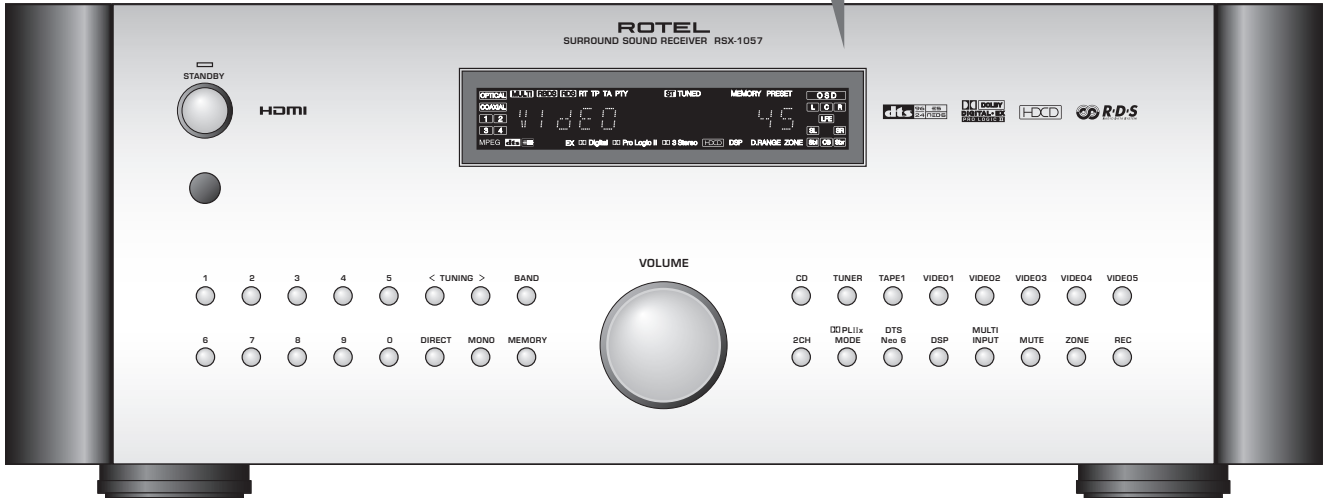

History

RSX1057(v01) Hardware Configuration

		Digital pcb Resistor setting	
Serial Number	Used VFD	R67V2	R417
~ 6191400	HNR08MM31	OPEN	10K
6241001 ~	HNA08MM37	10K	OPEN

SYMBOL	PARTS NO.	DESCRIPTION
	016 E-1459A00 PCB ASSY	
	501 E-1459	PCB ASSY (INPUT)
L301	021 TLAL02TB100K	MICRO INDUCTOR 10uH
L302	021 TLAL02TB101K	MICRO INDUCTOR 100uH
XT301	023 HC49U-001WR	CRYSTAL 14.31818MHZ
IC230-232	031 ADG704BRM	IC SMD (4CH MPX)
IC233,235	031 ADG774BR	IC SMD (MPX)
IC211,212	031 HEF4094BT	IC SMD (SHIFT REGISTER)
IC236	031 KS5520-1	IC (SCREEN DISPLAY)
IC234	031 LT1397CS	IC SMD (OPE AMP)
IC201-207	031 NJM5532M	IC SMD (OPE AMP)
IC223	031 NJM7812FA	IC (REG.+12VDC)
IC208-210,215	031 TC9163AF	IC (REG. +12VDC) KIA7812API-U
IC222	031 TC9459F	IC SMD (VOLUME) KIC9459F
IC213,214,216-221,224	031 TL072CD	IC SMD (OPE DUAL)
Q201-205	032 KRA107S	TRANSISTOR CHIP
Q206-218,224,225	032 KRC231S	TRANSISTOR CHIP
Q221	032 KTA1271	TRANSISTOR
D204	037 KDS226RTK	DIODE CHIP KDS226RTK
D201-203	037 KDS226RTK	DIODE CHIP KDS226RTK
C349,354-361,365,369-372,390,392	041 TUTES1A101-7TF	ELECTROLYTIC CAPACITOR 10V100uF
C366-368,C374,386,389	041 TUTES1A471-7TF	ELECTROLYTIC CAPACITOR 10V470uF
C229,258-281,298-309,397,398	041 TUTES1E470-7TF	ELECTROLYTIC CAPACITOR 25V47uF
C376,380	041 TUTES1H010-7TF	ELECTROLYTIC CAPACITOR 50V1uF
C230-257,282-287,296,297,310-326	041 TUTES1H100-7TF	ELECTROLYTIC CAPACITOR 50V10uF
C335-342,345,346,353,393-396	041 TUTES1H100-7TF	ELECTROLYTIC CAPACITOR 50V10uF
C379,382	041 TUTES1HR47-7TF	ELECTROLYTIC CAPACITOR 50V0.47uF
C387,388	043 TC50VCH220	CERAMIC CAPACITOR 22pF
C377,378	043 TC50VCH560	CERAMIC CAPACITOR 56pF
C383	047 ECJ2VB1H103K	CERAMIC CAPACITOR CHIP 0.01uF
C294,295	047 ECJ2VB1H153K	CERAMIC CAPACITOR CHIP 0.015uF
C288,289,290-293,351,352,399	047 ECJ2VF1H104Z	CERAMIC CAPACITOR CHIP 0.1uF
C375,385	047 ECJ2VF1H224Z	CERAMIC CAPACITOR CHIP 0.22uF
C201-228,327-334,347,348,384,343,344,381	047 ECJ2VG1H101J	CERAMIC CAPACITOR CHIP 100pF
R395-398,399,417,444	055 ERJ6ENF10R0V	RESISTOR CHIP 10
R418,419	055 ERJ6ENF1000V	RESISTOR CHIP 100
R201-214,216-221,226,282-285,300,301,316-323	055 ERJ6ENF1001V	RESISTOR CHIP 1K
R340-347,353,354,359,360,373,374,436,437,447	055 ERJ6ENF1001V	RESISTOR CHIP 1K
R352,369,370,375,400	055 ERJ6ENF1002V	RESISTOR CHIP 10K
R230-243,332-339,357,358,365,366,371,372,	055 ERJ6ENF1003V	RESISTOR CHIP 100K
R392-394,439,294,295,348-351,376,411-414	055 ERJ6ENF1003V	RESISTOR CHIP 100K
R446	055 ERJ6ENF1004V	RESISTOR CHIP 1M
R443	055 ERJ6ENF1201V	RESISTOR CHIP 1.2K
R450	055 ERJ6ENF1800V	RESISTOR CHIP 180
R296,297,367,368	055 ERJ6ENF1801V	RESISTOR CHIP 1.8K
R438	055 ERJ6ENF2003V	RESISTOR CHIP 200K
R258-281,302-315,361,362,457,458	055 ERJ6ENF2200V	RESISTOR CHIP 220
R441	055 ERJ6ENF2201V	RESISTOR CHIP 2.2K
R442	055 ERJ6ENF2202V	RESISTOR CHIP 22K
R405-410,415,416	055 ERJ6ENF2700V	RESISTOR CHIP 270
R435	055 ERJ6ENF2R2V	RESISTOR CHIP 2.2
R286-289,324-331	055 ERJ6ENF3303V	RESISTOR CHIP 330K
R355,356,451,452	055 ERJ6ENF3303V	RESISTOR CHIP 330K
R445	055 ERJ6ENF3901V	RESISTOR CHIP 3.9K
R222-225	055 ERJ6ENF3902V	RESISTOR CHIP 39K
R401-404	055 ERJ6ENF47R0V	RESISTOR CHIP 47
R448,449	055 ERJ6ENF47R0V	RESISTOR CHIP 47
R244-257,290-293,453,454,455,456	055 ERJ6ENF4701V	RESISTOR CHIP 4.7K
R440	055 ERJ6ENF5101V	RESISTOR CHIP 5.1K

SYMBOL	PARTS NO.	DESCRIPTION
R380-391	055 ERJ6ENF75R0V	RESISTOR CHIP 75
R298,299	055 ERJ6ENF8200V	RESISTOR CHIP 820
RLY201	063 A12W-K	RELAY A12W-K
JAK201-204	066 C-4792A01	6P PIN JACK AU (WHT/RED)
JK206,207	066 C-4833A01	6P PIN JACK AU (G/BLU/R)
CP201	068 B13B-PH-KS	CONNECTOR WAFER 13P
CNT100	068 C-4867A01	FPC CONNECTOR 17P (TOP TYPE)
016 E-1401B00 PCB ASSY		
	501 E-1401-C	PCB ASSY (MULTIINPUT)
IC715-718	031 TL072CD	IC SMD (OPE DUAL)
CMB707,708,CMC707,708,CMF707,708	041 TUTES1E470-7TF	ELECTROLYTIC CAPACITOR 25V47uF
CMS707,708	041 TUTES1E470-7TF	ELECTROLYTIC CAPACITOR 25V47uF
CMB703,704,CMC702,CMF703,704	041 TUTES1H100-7TF	ELECTROLYTIC CAPACITOR 50V10uF
CMS703,704,CMW702	041 TUTES1H100-7TF	ELECTROLYTIC CAPACITOR 50V10uF
C713,714	047 ECJ2VF1H104Z	CERAMIC CAPACITOR CHIP 0.1uF
CMB705,706,CMC703,CMF705,706,CMS705,706	047 ECJ2VG1H100D	CERAMIC CAPACITOR CHIP 10pF
CMB701,702,710,711,CMC701,710,CMF701,702,	047 ECJ2VG1H101J	CERAMIC CAPACITOR CHIP 100pF
CMF710,711,CMS701,702,710,711,	047 ECJ2VG1H101J	CERAMIC CAPACITOR CHIP 100pF
CMW701,703,710	047 ECJ2VG1H101J	CERAMIC CAPACITOR CHIP 100pF
RMB701,702,RMC701,RMF701,702	055 ERJ6ENF1000V	RESISTOR CHIP 100
RMS701,702,RMW701	055 ERJ6ENF1000V	RESISTOR CHIP 100
RMB705,706,RMB711,712,RMC703,705	055 ERJ6ENF1002V	RESISTOR CHIP 10K
RMF705,706,RMS705,706,711,712	055 ERJ6ENF1002V	RESISTOR CHIP 10K
RMB703,704,RMC702,RMF703,704	055 ERJ6ENF1003V	RESISTOR CHIP 100K
RMS703,704,RMW702	055 ERJ6ENF1003V	RESISTOR CHIP 100K
RMW703,704	055 ERJ6ENF1202V	RESISTOR CHIP 12K
RMB707,708,RMC707,708,RMF707,708	055 ERJ6ENF2200V	RESISTOR CHIP 220
RMS707,708	055 ERJ6ENF2200V	RESISTOR CHIP 220
RMF711,712	055 ERJ6ENF3001V	RESISTOR CHIP 3K
RMF709,710	055 ERJ6ENF3303V	RESISTOR CHIP 330K
RMB709,710,RMC704,RMS709,710	055 ERJ6ENF4301V	RESISTOR CHIP 4.3K
JAK702	066 C-4764A02	2P PIN JACK (BLK/BLK)
JAK701	066 C-4861A01	6P PIN JACK (WHT/RED)
016 E-1405C00 PCB ASSY		
	501 E-1405-B	PCB ASSY (POWER 1)
L801	021 2648701170	LINE FILTER COIL
(F801)	036 5ST3.15	FUSE 250VT3.15A
(F801)	036 5ST8	FUSE 250VT8A
R801	054 MOF12-3M3	MOF RESISTOR 1/2W 3.3m
CP803	068 4428505746	CONNECTOR WAFER 5P 7.92mm
CP116,117,231,232,801,802	068 B2P3-VH	CONNECTOR WAFER 2P
016 E-1406E00 PCB ASSY		
	501 E-1406-B	PCB ASSY (POWER 2)
IC901,903,904	031 NJM7805FA	IC (REG. +5VDC) KIA7805API-U
IC902,905	031 NJM7806FA	IC (REG. +6VDC) KIA7806API-U
IC909	031 NJM7812FA	IC (REG. +12VDC) KIA7812API-U
IC907	031 NJM7818FA	IC (REG. +18VDC) KIA7818API-U
IC906	031 NJM7906FA	IC (REG. -6VDC) KIA7906PI-U
IC908	031 NJM7918FA	IC (REG. -18VDC) KIA7918PI-U
Q901	032 TA1450-ST	TRANSISTOR 2SA1450AA-ST
Q251,252,902,903	033 TC3708-ST	TRANSISTOR 2SC3708AA-ST
DB951	034 KBPC2504W-F	POWER DIODE 25A 400V
D901,902,905,906,912-922,925-931	034 T1N4004-TB	DIODE 1N4004-F (AMMO)
D251,903,909	034 T1N4148-86	DIODE 1N4148TAP-50
D910	034 TRD27JST1	ZENER DIODE 27V
D904	034 TRD4.3EST1	ZENER DIODE 4.3V
D252	034 TRD6.8JST1	ZENER DIODE 6.8V
D911	034 TRD9.1JST1	ZENER DIODE 9.1V

SYMBOL	PARTS NO.	DESCRIPTION
F903,904	036 5ST2-R	FUSE 250VT2A
F901,902	036 5ST3.15-R	FUSE 250VT3.15A
C956-959	041 HC80V8200UF	ELECTROLYTIC CAPACITOR 80V8200uF
C251	041 TUTES1A471-7TS	ELECTROLYTIC CAPACITOR 10V470uF
C904	041 TUTES1C102-7TS	ELECTROLYTIC CAPACITOR 16V1000uF
C901,910,918,919	041 TUTES1C472-7TS	ELECTROLYTIC CAPACITOR 16V4700uF
C902,905,909,911,920,921,931,932,938	041 TUTES1H010-7TF	ELECTROLYTIC CAPACITOR 50V1uF
C907	041 TUTES1H220-7TF	ELECTROLYTIC CAPACITOR 50V22uF
C906	041 TUTES1H470-7TF	ELECTROLYTIC CAPACITOR 50V47uF
C929,930	041 TUTES1V332-7TS	ELECTROLYTIC CAPACITOR 35V3300uF
C922,936	041 TUTES1V471-7TS	ELECTROLYTIC CAPACITOR 35V470uF
C908	041 UTES1C103-7	ELECTROLYTIC CAPACITOR 16V10000uF
C903,951-955	043 TC500V103	CERAMIC CAPACITOR 500V0.01uF
C913-917,924-928	044 TBFO14D0103J	M.P CAPACITOR 63V0.01uF
R905,906	053 CR14-010J-A	CARBON RESISTOR 1/4W 1
R252,902,909	053 CR14-102J-A	CARBON RESISTOR 1/4W 1K
R908	053 CR14-103J-A	CARBON RESISTOR 1/4W 10K
R253	053 CR14-152J-A	CARBON RESISTOR 1/4W 1.5K
R911,917	053 CR14-220J-A	CARBON RESISTOR 1/4W 22
R910,916	053 CR14-222J-A	CARBON RESISTOR 1/4W 2.2K
R907	053 CR14-470J-A	CARBON RESISTOR 1/4W 47
R903	053 CR14-473J-A	CARBON RESISTOR 1/4W 47K
R251	053 CR14-682J-A	CARBON RESISTOR 1/4W 6.8K
R901	054 1WS10J	MOF RESISTOR 1W 10
R904,914,915,920,921,922	054 2WS1JF	MOF RESISTOR 2W 10
RLY901,902	063 OSA-SS-224DM5	RELAY 24V
CP403	068 B10B-PH-KS	CONNECTOR WAFER 10P
CP251	068 B2B-EH	CONNECTOR WAFER 2P
CP411-413	068 B2B-PH-KS	CONNECTOR WAFER 2P
CP204	068 B2P3-VH	CONNECTOR WAFER 2P
CP205,902	068 B3B-EH	CONNECTOR WAFER 3P
CP951	068 B3P-VH	CONNECTOR WAFER 3P
CP404,801	068 B5B-PH-KS	CONNECTOR WAFER 5P
CP301	068 B6B-PH-KS	CONNECTOR WAFER 6P
CP901	068 B7B-EH	CONNECTOR WAFER 7P
CP106	068 B7B-PH-KS	CONNECTOR WAFER 7P
CP202	068 B9B-PH-KS	CONNECTOR WAFER 9P
016 X-1407C01-03 PCB ASSY		
	501 X-1407-B	PCB ASSY (SPEAKER)
C966-970	044 TBF014D0472J	M.P CAPACITOR 63V4700pF
C951-955	044 TBF014D0473J	M.P CAPACITOR 63V0.047uF
R951-955	054 2WS10JF	MOF RESISTOR 2W 10
SW100	061 C-4172A13	PUSH SWITCH SPUN12XT131
JAK951,952	067 C-4794A00	4P SPEAKER TERMINAL (RED/BLK)
JAK953	067 C-4862A01	2P SPEAKER TERMINAL (RED/BLK)
CP101	068 B2B-PH-KS	CONNECTOR WAFER 2P
CT202,910,951	068 B2P-VH	CONNECTOR WAFER 2P
CT203,911	068 B3P-VH	CONNECTOR WAFER 3P
016 X-1408A01-03 PCB ASSY		
	501 X-1408-B	PCB ASSY (FRONT, ENCODER)
X101	023 CST10.0MTW	CERAMIC RESONATOR
IC100	031 CXP82832-366Q	IC SMD (CPU) .
RMC101	031 SBX3010-52B	IC (REMOTE EYE)
Q101,102	032 TC3708-ST	TRANSISTOR 2SC3708AA-ST
D101-106	034 T1N4148-86	DIODE 1N4148TAP-50
FIP1* (use with R417)	035 HNR08MM31	FL TUBE
FIP1* (use with R67V2)	035 HNA08MM37	FL TUBE
C114	041 TUTES1H010-7TF	ELECTROLYTIC CAPACITOR 50V1uF
C119	041 TUTES1H3R3-7TF	ELECTROLYTIC CAPACITOR 50V3.3uF

SYMBOL	PARTS NO.	DESCRIPTION
C117	041 TUTES1H4R7-7TF	ELECTROLYTIC CAPACITOR 50V4.7uF
C101-107	043 TC50V101	CERAMIC CAPACITOR 50V100pF
C115	043 TC50V103	CERAMIC CAPACITOR 0.01uF
C118	043 TC50V223	CERAMIC CAPACITOR 0.022uF
C100,112,113	043 TC50V473	CERAMIC CAPACITOR 0.047uF
C108-111	043 TC50V821	CERAMIC CAPACITOR 820pF
R101-104,124-126,142	054 TMF1001	METAL FILM RESISTOR 1/4W 1K
R109,114-119	054 TMF1002	METAL FILM RESISTOR 1/4W 10K
(R121)	054 TMF1800	METAL FILM RESISTOR 1/4W 180
(R121)	054 TMF4700	METAL FILM RESISTOR 1/4W 470
R122,123	054 TMF4701	METAL FILM RESISTOR 1/4W 4.7K
R105-108,110-113	054 TMF4702	METAL FILM RESISTOR 1/4W 47K
R120	054 TMF47R0	METAL FILM RESISTOR 1/4W 47
ESW101	056 C-4678A01	ROTARY ENCODER 3P (WITHOUT DETENT)
SW101-132	061 C-4679A03	TACT SWITCH 5mm GRY HV061050GS
CP105	068 B2B-PH-KS	CONNECTOR WAFER 2P
CP110	068 B3B-PH-KS	CONNECTOR WAFER 3P
CP102	068 B4B-PH-KS	CONNECTOR WAFER 4P
016 E-1413B00 PCB ASSY		
L101,201,301,401,501	501 E-1413-B	PCB ASSY (POWER AMPLIFIER)
Q702	021 LF167A00	SPEAKER COIL 1.0F7T
Q109,209,309,409,509	032 KRC107M	TRANSISTOR KRC107M
Q112,212,312,412,512	033 A1360-OY	TRANSISTOR 2SA1360-OY
Q110,210,310,410,510	033 A1859-Y	TRANSISTOR 2SA1859A-Y
Q111,211,311,411,511	033 C3423-OY	TRANSISTOR 2SC3423-OY
Q101-105,201-205,301-305	033 C4883-Y	TRANSISTOR 2SC4883A-Y
Q401-405,501-505,701	033 KTA1268-GRBL	TRANSISTOR KTA1268-GRBL
Q106-108,206-208,306-308,406-408,506-508	033 KTA1268-GRBL	TRANSISTOR KTA1268-GRBL
D101,102,201,202,301,302	033 KTC3200-GRBL	TRANSISTOR KTC3200-GRBL
D401,402,501,502	034 2058322101	DIODE 1N4148 (5mm pitch)
D701	034 T1N4148-86	DIODE 1N4148
C106,206,306,406,506	034 TRD12JST1	ZENER DIODE 12V
C107,207,307,407,507,701,702	041 TUTES1A221-7TF	ELECTROLYTIC CAPACITOR 10V220uF
C111,112,211,212,311,312,411,412,511,512	041 TUTES1H010-7TF	ELECTROLYTIC CAPACITOR 50V1uF
C108,208,308,408,508	041 TUTES1H100-7TF	ELECTROLYTIC CAPACITOR 50V10uF
C703	041 TUTES1H220-7TF	ELECTROLYTIC CAPACITOR 50V22uF
C105,205,305,405,505	041 TUTES1H470-7TF	ELECTROLYTIC CAPACITOR 50V47uF
C109,110,209,210,309,310,409,410,509,510	041 TUTES1H4R7-7FB	ELECTROLYTIC CAPACITOR 50V4.7uF
C104,204,304,404,504	041 TUTES1J471-7TS	ELECTROLYTIC CAPACITOR 63V470uF
C102,202,302,402,502	043 TC50V181	CERAMIC CAPACITOR 180pF
C101,201,301,401,501	043 TC50V271	CERAMIC CAPACITOR 270pF
C103,203,303,403,503	043 TC50V391	CERAMIC CAPACITOR 390pF
VR101,201,301,401,501	043 TC50VCH5R6-A	CERAMIC CAPACITOR AXIAL
R705,706	051 SFR001-102	SEMI-FIXED RESISTOR VM6CKPH1S-1K
R141,241,341,441,541	054 2WS1KJF	MOF RESISTOR 2W 1K
R101,102,201,202,301,302,401,402,501,502	054 MPR5W0.27RJ-T	METAL PLATE RESISTOR 5W 0.27RX2
R113,213,313,413,513	054 TMF16-1001	METAL FILM RESISTOR 1/6W 1K
R702	054 TMF16-1002	METAL FILM RESISTOR 1/6W 10K
R126,127,226,227,326,327,426,427,526,527	054 TMF16-1003	METAL FILM RESISTOR 1/6W 100K
R109,110,209,210,309,310,409,410,509,510	054 TMF16-1200	METAL FILM RESISTOR 1/6W 120
R112,212,312,412,512	054 TMF16-1201	METAL FILM RESISTOR 1/6W 1.2K
R704	054 TMF16-1500	METAL FILM RESISTOR 1/6W 150
R105,106,205,206,305,306,405,406,505,506	054 TMF16-1503	METAL FILM RESISTOR 1/6W 150K
R128,228,328,428,528	054 TMF16-150R	METAL FILM RESISTOR 1/6W 15
R129,229,329,429,529	054 TMF16-1801	METAL FILM RESISTOR 1/6W 1.8K
R116-118,216-218,316-318,416-418,516-518	054 TMF16-2001	METAL FILM RESISTOR 1/6W 2K
R703	054 TMF16-2202	METAL FILM RESISTOR 1/6W 22K
R103,104,203,204,303,304,403,404,503,504	054 TMF16-3301	METAL FILM RESISTOR 1/6W 3.3K
	054 TMF16-3302	METAL FILM RESISTOR 1/6W 33K

SYMBOL	PARTS NO.	DESCRIPTION
R132-135,232-235,332-335,432-435,532-535	054 TMF16-39R0	METAL FILM RESISTOR 1/6W 39
R114,214,314,414,514	054 TMF16-4302	METAL FILM RESISTOR 1/6W 43K
R119-125,219-225,319-325,419-425,519-525	054 TMF16-5600	METAL FILM RESISTOR 1/6W 560
R131,231,331,431,531	054 TMF16-6801	METAL FILM RESISTOR 1/6W 6.8K
R701	054 TMF16-6802	METAL FILM RESISTOR 1/6W 68K
R111,211,311,411,511	054 TMF16-68R0	METAL FILM RESISTOR 1/6W 68
R107,108,207,208,307,308,407,408,507,508	054 TMF16-7500	METAL FILM RESISTOR 1/6W 750
R130,230,330,430,530	054 TMF16-9100	METAL FILM RESISTOR 1/6W 910
R136,137,236,237,336,337,436,437,536,537	054 TMF1000	METAL FILM RESISTOR 1/4W 100
R140,240,340,440,540	054 TMF2200	METAL FILM RESISTOR 1/4W 220
R138,139,238,239,338,339	054 TMF3R30	METAL FILM RESISTOR 1/4W 3.3
R438,439,538,539	054 TMF3R30	METAL FILM RESISTOR 1/4W 3.3
CP201	068 B10B-PH-KS	CONNECTOR WAFER 10P
016 E-1419B00 PCB ASSY		
	501 E-1419-B	PCB ASSY (OUTPUT)
IC702	031 TC9162AF	IC SMD (SWITCH ALLEY) KIC9162AF
IC701	031 TC9163AF	IC SMD (SWITCH ALLEY) KIC9163AF
IC709,710	031 TC9482F	IC SMD (VOLUME) KIC9482F
IC707,708,IC703-706,711-714	031 TL072CD	IC SMD (OPE DUAL)
QC702,QCB701,QF701,QS701,QSW702	032 KRA107S	TRANSISTOR CHIP
Q701-703,QBL/R701,QC701,QFL/R701	032 KRC231S	TRANSISTOR CHIP
QSL/R701,QSW701	032 KRC231S	TRANSISTOR CHIP
D701,702,DC701,DCB701,DF701,DS701	037 KDS184RTK	DIODE CHIP
DSW701	037 KDS184RTK	DIODE CHIP
C701-705,707,709,711,CB701,702,	041 TUTES1E470-7TF	ELECTROLYTIC CAPACITOR 25V47uF
CCB703,704,CCW701-704,CF701-704	041 TUTES1E470-7TF	ELECTROLYTIC CAPACITOR 25V47uF
CMW710,711,CS701-704	041 TUTES1E470-7TF	ELECTROLYTIC CAPACITOR 25V47uF
CBL/R702,704,705,708,CCT702,704,705,708,	041 TUTES1H100-7TF	ELECTROLYTIC CAPACITOR 50V10uF
CFL/R702,704,705,708,CMW705,	041 TUTES1H100-7TF	ELECTROLYTIC CAPACITOR 50V10uF
CSL/R702,704,705,708,CSW702,704,705,708	041 TUTES1H100-7TF	ELECTROLYTIC CAPACITOR 50V10uF
CMW707	047 ECJ2VB1H333K	CERAMIC CAPACITOR CHIP 0.033uF
C706,708,710,712,713,714	047 ECJ2VF1H104Z	CERAMIC CAPACITOR CHIP 0.1uF
CCB705,CCT709,CF705,CS705,CSW709	047 ECJ2VF1H104Z	CERAMIC CAPACITOR CHIP 0.1uF
CMW706	047 ECJ2VF1H224Z	CERAMIC CAPACITOR CHIP 0.22uF
CBL/R707,CCT707,CFL/R707,CSL/R707	047 ECJ2VG1H100D	CERAMIC CAPACITOR CHIP 10pF
CBL/R701,703,706,CCT701,703,706	047 ECJ2VG1H101J	CERAMIC CAPACITOR CHIP 100pF
CFL/R701,703,706,CSW701,703,706,707	047 ECJ2VG1H101J	CERAMIC CAPACITOR CHIP 100pF
CSL/R701,703,706,CMW704	047 ECJ2VG1H101J	CERAMIC CAPACITOR CHIP 100pF
CMW708,709	047 ECJ2VG1H222J	CERAMIC CAPACITOR CHIP 0.0022uF
1056J1-1056J5,J701	055 ERJ6GEY0R00V	RESISTOR CHIP 0
RBL/R705,RCT705,RFL/R705,RSL/R705,	055 ERJ6ENF1000V	RESISTOR CHIP 100
RSW705	055 ERJ6ENF1000V	RESISTOR CHIP 100
RBL/R701,707,RCT701,707,RFL/R701,707	055 ERJ6ENF1000V	RESISTOR CHIP 100
RMW709,RSL/R701,707,RSW701,707	055 ERJ6ENF1000V	RESISTOR CHIP 100
R703-705,708-710,713-715,718-720	055 ERJ6ENF1001V	RESISTOR CHIP 1K
RBL/R712,RCT712,RFL/R712,RMW712,713	055 ERJ6ENF1001V	RESISTOR CHIP 1K
RSL/R712,RSW710,712,R721-728	055 ERJ6ENF1001V	RESISTOR CHIP 1K
RBL/R709,RCT709,RFL/R703,709	055 ERJ6ENF1002V	RESISTOR CHIP 10K
RMW711,715,716,RSL/R709	055 ERJ6ENF1002V	RESISTOR CHIP 10K
RBL/R706,RCB705,RCT706,713,RFL/R706	055 ERJ6ENF1003V	RESISTOR CHIP 100K
RS705,RSL/R706,RSW706,713,	055 ERJ6ENF1003V	RESISTOR CHIP 100K
RBL/R702,708,711,RCB706,RCT702,708,711,714	055 ERJ6ENF1003V	RESISTOR CHIP 100K
RF705,706,RFL/R702,708,711,RMW710,714	055 ERJ6ENF1003V	RESISTOR CHIP 100K
RS706,RSL/R702,708,711,RSW702,708,711,714	055 ERJ6ENF1003V	RESISTOR CHIP 100K
RBL/R704,RCT704,RSL/R704	055 ERJ6ENF1201V	RESISTOR CHIP 1.2K
RBL/R703,RCT703,RMW706,707,RSL/R703	055 ERJ6ENF1202V	RESISTOR CHIP 12K
RSW709	055 ERJ6ENF1502V	RESISTOR CHIP 15K
R729,730,RMW705	055 ERJ6ENF1801V	RESISTOR CHIP 1.8K
RSW703	055 ERJ6ENF2002V	RESISTOR CHIP 20K

SYMBOL	PARTS NO.	DESCRIPTION
R701,702,706,707,711,712,716,717	055 ERJ6ENF2200V	RESISTOR CHIP 220
RB701,702,RCB703,704,RCW701-704	055 ERJ6ENF2200V	RESISTOR CHIP 220
RF701-704,RMW717,718,RS701-704	055 ERJ6ENF2200V	RESISTOR CHIP 220
RBL/R710,RCT710,RFL/R710,RSL/R710	055 ERJ6ENF2201V	RESISTOR CHIP 2.2K
RMW708	055 ERJ6ENF2702V	RESISTOR CHIP 27K
RSW704	055 ERJ6ENF3301V	RESISTOR CHIP 3.3K
RFL/R704	055 ERJ6ENF3901V	RESISTOR CHIP 3.9K
RA731,733	055 ERJ6ENF4701V	RESISTOR CHIP 4.7K
RA732,734	055 ERJ6ENF5601V	RESISTOR CHIP 5.6K
RY701,702	063 A12W-K	RELAY A12W-K
TER702	066 C-4784A02	4P PIN JACK (B/B)
TER701	066 C-4792A01	6P PIN JACK (R/W)
CP401,402,702	068 B15B-PH-KS	CONNECTOR WAFER 15P
CP703	068 B2B-PH-KS	CONNECTOR WAFER 2P
CP204,701	068 B3B-PH-KS	CONNECTOR WAFER 3P
CP203	068 B6B-PH-KS	CONNECTOR WAFER 6P
016 E-1442B00 PCB ASSY		
	501 E-1442	PCB ASSY (VIDEO)
L301,303	021 TLAL02TB100K	MICRO INDUCTOR 10uH
L302,304,LV404-406	021 TLAL02TB101K	MICRO INDUCTOR 100uH
LV401-403,407-410	021 TLAL02TB270K	MICRO INDUCTOR 27uH
LV411	021 TLAL02TB4R7K	MICRO INDUCTOR 4.7uH
XT403	023 CSB503F2	CERAMIC RESONATOR 500KHz
XT301,302	023 HC49U-001WR	CRYSTAL 14.31818MHz
XT402	023 HC49US-010	CRYSTAL HC49US3.579545MHz
XT401	023 HC49US-011	CRYSTAL HC49US4.433619MHz
ICV404	031 KIA7809AF-RTF/P	IC SMD (REG.+9VDC)
IC303,309	031 KS5520-1	IC SMD (SCREEN DISPLAY)
ICV403,407	031 NJM2283M	IC (VIDEO SWITCH)
ICV405	031 TA1270BF	IC SMD (VIDEO)
ICV402	031 TC90A69F	IC SMD (Y/C SEPARATOR)
IC301,302,307,308	031 TC9163AF	IC SMD (SWITCH ALLEY) KIC9163AF
ICV406	031 TDA4665T	IC SMD (1H DELAY)
IC304-306,310,313,ICV401	031 TSH94ID	IC SMD (VIDEO AMP)
Q301,302,QV406	032 KRC107S	TRANSISTOR CHIP
QV401-405	032 TC3708-ST	TRANSISTOR 2SC3708AA-ST
DV401	034 T1N4148-86	DIODE 1N4148TAP-50
DZ402	034 TRD5.1JST1	ZENER DIODE 5.1V
D302,303	037 KDS184RTK	DIODE CHIP
D301	037 KDS226RTK	DIODE CHIP
C326-331,341,342,390-393,CV403-407, CV410,416,417,430,438,439450,467,477	041 TUTES1A101-7TF	ELECTROLYTIC CAPACITOR 10V100uF
C311,320,325,346,355,360	041 TUTES1A101-7TF	ELECTROLYTIC CAPACITOR 10V100uF
CV465	041 TUTES1A471-7TF	ELECTROLYTIC CAPACITOR 10V470uF
CV482	041 TUTES1E101-7TF	ELECTROLYTIC CAPACITOR 25V100uF
CV414	041 TUTES1E220-7TF	ELECTROLYTIC CAPACITOR 25V22uF
CV425,426,448,452,487	041 TUTES1E221-7TF	ELECTROLYTIC CAPACITOR 25V220uF
C314,316,349,351,CV454	041 TUTES1E470-7TF	ELECTROLYTIC CAPACITOR 25V47uF
C305-309,337-340	041 TUTES1H010-7TF	ELECTROLYTIC CAPACITOR 50V1uF
CV412,441,447,479,480,484,485	041 TUTES1H100-7TF	ELECTROLYTIC CAPACITOR 50V10uF
CV460,462	041 TUTES1H100-7TF	ELECTROLYTIC CAPACITOR 50V10uF
CV458	041 TUTES1H2R2-7TF	ELECTROLYTIC CAPACITOR 50V2.2uF
C315,318,350,353	041 TUTES1HR22-7TF	ELECTROLYTIC CAPACITOR 50V0.22uF
C323,324,358,359	041 TUTES1HR47-7TF	ELECTROLYTIC CAPACITOR 50V0.47uF
C312,313,347,348	043 TC50VCH220	CERAMIC CAPACITOR 22pF
CV461,476	043 TC50VCH560	CERAMIC CAPACITOR 56pF
CV457	044 TBF014D0104J	M.P CAPACITOR 63V0.1uF
CV463	044 TBF014D0222J	M.P CAPACITOR 63V0.0022uF
CV424	044 TBF014D0223J	M.P CAPACITOR 63V0.022uF
	044 TBF074D0474J	M.P CAPACITOR 63V0.47uF

SYMBOL	PARTS NO.	DESCRIPTION
C319,354,CV420-423,427-429,434,435,459	047 ECJ2VB1H103K	CERAMIC CAPACITOR CHIP 0.01uF
C301-304,334-336,371-388,CV401,402,411,413,	047 ECJ2VF1H104Z	CERAMIC CAPACITOR CHIP 0.1uF
CV415,418,419,431,440,446,449,453,464,466,	047 ECJ2VF1H104Z	CERAMIC CAPACITOR CHIP 0.1uF
CV478,481,483,486,432,444,445,451,468-473	047 ECJ2VF1H104Z	CERAMIC CAPACITOR CHIP 0.1uF
C321,332,356,361,310,345	047 ECJ2VF1H224Z	CERAMIC CAPACITOR CHIP 0.22uF
C317,322,352,357	047 ECJ2VG1H101J	CERAMIC CAPACITOR CHIP 100pF
CV437,443,455,456	047 ECJ2VG1H120J	CERAMIC CAPACITOR CHIP 12pF
CV408,409,436,442	047 ECJ2VG1H220J	CERAMIC CAPACITOR CHIP 22pF
CV474,475	047 ECJ2VG1H560J	CERAMIC CAPACITOR CHIP 56pF
CV433	047 ECJ2VG1H681J	CERAMIC CAPACITOR CHIP 680pF
R334,368-373,411,412,421,427,459,466,467,	055 ERJ6ENF10R0V	RESISTOR CHIP 10
RV401,402,438,447,450,456,459,462	055 ERJ6ENF10R0V	RESISTOR CHIP 10
R340-348,393-398,RV410,423,424,448,449	055 ERJ6ENF1000V	RESISTOR CHIP 100
R322,323,326-329,338,349-364,367,389-392,	055 ERJ6ENF1001V	RESISTOR CHIP 1K
R399-405,407,408,415,416,425,428,458	055 ERJ6ENF1001V	RESISTOR CHIP 1K
RV403,439	055 ERJ6ENF1001V	RESISTOR CHIP 1K
R460,461,RV404-406,416,430,436,451,457,	055 ERJ6ENF1002V	RESISTOR CHIP 10K
RV458,460,461	055 ERJ6ENF1002V	RESISTOR CHIP 10K
R330,417	055 ERJ6ENF1003V	RESISTOR CHIP 100K
R339,426	055 ERJ6ENF1004V	RESISTOR CHIP 1M
R337,406,424,RV414,428,434	055 ERJ6ENF1201V	RESISTOR CHIP 1.2K
RA471,472,RV408,412	055 ERJ6ENF1500V	RESISTOR CHIP 150
R333,420	055 ERJ6ENF1501V	RESISTOR CHIP 1.5K
RV415,429,435	055 ERJ6ENF1502V	RESISTOR CHIP 15K
R331,418	055 ERJ6ENF2003V	RESISTOR CHIP 200K
R320,321,324,325,385-388	055 ERJ6ENF2200V	RESISTOR CHIP 220
R335,422	055 ERJ6ENF2202V	RESISTOR CHIP 22K
R429,437,RV442,443	055 ERJ6GEYJ2R2V	RESISTOR CHIP 2.2
RV425,446	055 ERJ6ENF3300V	RESISTOR CHIP 330
RV445	055 ERJ6ENF3301V	RESISTOR CHIP 3.3K
RV444	055 ERJ6ENF3302V	RESISTOR CHIP 33K
R336,365,366,409,410,423	055 ERJ6ENF3901V	RESISTOR CHIP 3.9K
RV452,453	055 ERJ6ENF4701V	RESISTOR CHIP 4.7K
RV418,419	055 ERJ6GEYJ4R7V	RESISTOR CHIP 4.7
R332,419	055 ERJ6ENF5101V	RESISTOR CHIP 5.1K
RV417,431,437	055 ERJ6ENF5600V	RESISTOR CHIP 560
RV454,455	055 ERJ6ENF5601V	RESISTOR CHIP 5.6K
R301-319,375-384,464,465,RV409,440,441	055 ERJ6ENF75R0V	RESISTOR CHIP 75
RV413,426,427,432,433	055 ERJ6ENF8200V	RESISTOR CHIP 820
SW305,306	066 4TR-2964#10	3P PIN JACK AU (YEL)
SW301-303	066 C-4604B02	4P MINI DIN JACK YKF51-5520N
SW304	066 C-4860A01	4P PIN JACK AU (YEL)
	016 E-1449A00 PCB ASSY	
	501 E-1449	PCB ASSY (DIGITAL)
IC443	019 0009-P	POWER TR.BUSH
IC443	019 TO-220	MICA SHEET TBM-51W-15 #9036
T431-434	021 2888000010	PULSE TRANS FP-110
XT402	023 CXO-002	CRYSTAL 12.288MHz
XT401	023 HC49U-009	CRYSTAL HC49U24.576MHz
L431-434,LCB451,LCW451,LF451,LS451	025 BK2125HS102	BEAD COIL CHIP
L401,435,436	025 BK2125HS601	BEAD COIL CHIP
IC438	031 39VF040-V34	IC PLCC (SOFT WRITING)
IC440	031 74HC00	IC SMD (QUAD NAND GATE) 74HC00
IC436,446	031 74HC125	IC SMD (QUAD BUFFER) 74HCT125D
IC441,442	031 74HC157	IC SMD (QUAD MPX) 74VHC157-
IC445	031 74HC244	IC SMD (OCTAL BUFFER) 74VHC244-SOP
IC431	031 AK4114VQ	IC SMD (D/A TRANSCEIVER)
IC447-450	031 AK4396VF	IC SMD (DAC)
IC432	031 AK5383VS	IC SMD (A/D CONVERTER)

SYMBOL	PARTS NO.	DESCRIPTION
IC403	031 AM29F004BT-X57	IC PLCC (FLASH MEMORY)
IC443	031 AME1117BCBT	IC (REGULATOR)
IC444	031 AME1117CCGT	IC SMD (REGULATOR) ABF
IC404	031 AT24C16A10PI-2.7	IC SMD (EPROM)
IC437	031 CS49400	IC SMD (DSP) CS49400-3
IC405	031 HIN232CB	IC SMD (TRANSMITTER RECEIVER)
IC402	031 IS62C256	IC SMD (SRAM)
IC439	031 K4S161622D	IC SMD (MEMORY)
IC406,407	031 LTV817	IC (PHOTO COUPLER)
IC433-435,451-454	031 TL072CD	IC SMD (OPE DUAL)
IC401	031 TMP95C063F	IC SMD (MICON)
Q401,QCW451,QFL/R451	032 KRC107S	TRANSISTOR CHIP
Q402-404	032 KRC231S	TRANSISTOR CHIP
D401-407	037 KDS184RTK	DIODE CHIP
C430	041 SCDA5R5104V	SUPER CAPACITOR
C480,481,484,487,C406	041 TUTES1A101-7TF	ELECTROLYTIC CAPACITOR 10V100uF
C454-462,512-519,CAL/R401-404	041 TUTES1E470-7TF	ELECTROLYTIC CAPACITOR 25V47uF
CCB455,CCW455,CF455,CS455	041 TUTES1E470-7TF	ELECTROLYTIC CAPACITOR 25V47uF
C418-421	041 TUTES1H010-7TF	ELECTROLYTIC CAPACITOR 50V1uF
C414,417,438,439,441-443,453,482,483	041 TUTES1H100-7TF	ELECTROLYTIC CAPACITOR 50V10uF
C485,486,CBL/R454,CCB454,456,CCT454	041 TUTES1H100-7TF	ELECTROLYTIC CAPACITOR 50V10uF
CCW454,456,CF454,456,CFL/R454	041 TUTES1H100-7TF	ELECTROLYTIC CAPACITOR 50V10uF
CS454,456,CSL/R454,CSW454	041 TUTES1H100-7TF	ELECTROLYTIC CAPACITOR 50V10uF
C503	041 TUTES1H2R2-7TF	ELECTROLYTIC CAPACITOR 50V2.2uF
C416	041 TUTES1H3R3-7TF	ELECTROLYTIC CAPACITOR 50V3.3uF
C415	041 TUTES1HR22-7TF	ELECTROLYTIC CAPACITOR 50V0.22uF
C440	041 TUTES1HR47-7TF	ELECTROLYTIC CAPACITOR 50V0.47uF
CAL/R408,CSW452,453	047 ECJ2VB1H103K	CERAMIC CAPACITOR CHIP 0.01uF
CCT455,CFL/R455	047 ECJ2VB1H223K	CERAMIC CAPACITOR CHIP 0.022uF
C501	047 ECJ2VC1H122J	CERAMIC CAPACITOR CHIP 1200pF
C409-411,422-428,436,437,447,450,451	047 ECJ2VF1H104Z	CERAMIC CAPACITOR CHIP 0.1uF
C467-479,488-490,C493-496,498,500,504-509	047 ECJ2VF1H104Z	CERAMIC CAPACITOR CHIP 0.1uF
C520-523,CCB451-453,CCW451-453,	047 ECJ2VF1H104Z	CERAMIC CAPACITOR CHIP 0.1uF
CF451-453,CS451-453,C401-405,407,408,	047 ECJ2VF1H104Z	CERAMIC CAPACITOR CHIP 0.1uF
C429,431-435,444-446,448,452,463-465,	047 ECJ2VF1H104Z	CERAMIC CAPACITOR CHIP 0.1uF
C491,499,510,511,CAL/R405	047 ECJ2VF1H104Z	CERAMIC CAPACITOR CHIP 0.1uF
C449,C5383	047 ECJ2VF1H224Z	CERAMIC CAPACITOR CHIP 0.22uF
CBL/R452,453,CCT452,453,CFL/R452,453	047 ECJ2VG1H121J	CERAMIC CAPACITOR CHIP 120pF
C412,413	047 ECJ2VG1H270J	CERAMIC CAPACITOR CHIP 27pF
CBL/R451,CCT451,CFL/R451,CSL/R451,CSW451	047 ECJ2VG1H331J	CERAMIC CAPACITOR CHIP 330pF
CAL/R406,407	047 ECJ2VG1H471J	CERAMIC CAPACITOR CHIP 470pF
C502	047 ECJ2VG1H680J	CERAMIC CAPACITOR CHIP 68pF
RM419,420	055 CN43-101	NETWORK RESISTOR CHIP 100
RM403-409	055 CN43-103	NETWORK RESISTOR CHIP 10K
RM410-418	055 CN43-331	NETWORK RESISTOR CHIP 330
RM401,402	055 CN43-332	NETWORK RESISTOR CHIP 3.3K
R407,408,426,444,445	055 ERJ6ENF10R0V	RESISTOR CHIP 10
R405,406,409-411,458,4395	055 ERJ6ENF1000V	RESISTOR CHIP 100
R427,428,448,451,459-462,476-479,418	055 ERJ6ENF1000V	RESISTOR CHIP 100
RBL/R458,RCT458,RFL/R458,RSL/R458	055 ERJ6ENF1001V	RESISTOR CHIP 1K
RSW458	055 ERJ6ENF1001V	RESISTOR CHIP 1K
R415-416,430,R1056,R401,402,412-414,447	055 ERJ6ENF1002V	RESISTOR CHIP 10K
RAL/R401,402,404,405, R417*, R67V2*	055 ERJ6ENF1002V	RESISTOR CHIP 10K
RBL/R457,RCT457,RFL/R457,RSL/R457,RSW457	055 ERJ6ENF1003V	RESISTOR CHIP 100K
R403	055 ERJ6ENF1004V	RESISTOR CHIP 1M
R446	055 ERJ6ENF1802V	RESISTOR CHIP 18K
R480,RAL/R408,411	055 ERJ6ENF22R0V	RESISTOR CHIP 22
R452-457,466-473,R435-438	055 ERJ6ENF2200V	RESISTOR CHIP 220
R463,RAL/R406,409	055 ERJ6ENF3001V	RESISTOR CHIP 3K
R464,465	055 ERJ6ENF3301V	RESISTOR CHIP 3.3K

SYMBOL	PARTS NO.	DESCRIPTION
R439-443	055 ERJ6ENF4700V	RESISTOR CHIP 470
R404,420-425,419	055 ERJ6ENF4701V	RESISTOR CHIP 4.7K
R429,449,450,474,475,5383,RAL/R403	055 ERJ6ENF4702V	RESISTOR CHIP 47K
RBL/R451-453,455,456,RCT451-453,455,456	055 ERJ6ENF5601V	RESISTOR CHIP 5.6K
RFL/R451-453,455,456,RSW451-453,455,456	055 ERJ6ENF5601V	RESISTOR CHIP 5.6K
RSL/R451-453,455,456	055 ERJ6ENF5601V	RESISTOR CHIP 5.6K
R431-434	055 ERJ6ENF75R0V	RESISTOR CHIP 75
RAL/R407,410	055 ERJ6ENF9100V	RESISTOR CHIP 910
RBL/R454,RCT454,RFL/R454,RSL/R454,	055 ERJ6ENF9101V	RESISTOR CHIP 9.1K
RSW454	055 ERJ6ENF9101V	RESISTOR CHIP 9.1K
RLY401-403	063 A12W-K	RELAY A12W-K
JAK407-413	065 YKB21-5103A	3.5Φ MINIATURE JACK (ST)
JAK401,402	066 C-4859A01	2P PIN JACK AU (BLK)
JAK406	066 SY010-8P/K	RJ45 TERMINAL
JAK404,405	066 TORX142L	OPTICAL RECEIVER
JAK403	066 TOTX142L	OPTICAL TRANSMITTER
CP405,408	068 B10B-PH-KS	CONNECTOR WAFER 10P
CP409	068 B12B-PH-KS	CONNECTOR WAFER 12P
CP451	068 B2B-PH-KS	CONNECTOR WAFER 2P
CP406	068 B7B-PH-KS	CONNECTOR WAFER 7P
CP410	068 B8B-PH-KS	CONNECTOR WAFER 8P
(IC403,438)	068 PLCC32TS	IC SOCKET 32P
	016 E-1450G00 PCB ASSY	
	501 E-1450	PCB ASSY (HDMI)
L1-8	021 ACM2012D	EMC FILTER COIL ACM2012D-900-2P
L9-12	021 ACM2012H	EMC FILTER COIL ACM2012H-900-2P
L13,14	025 BK2125HS101	BEAD COIL CHIP
IC6,15	031 74HC04	IC SMD
IC8,17	031 74HC123	IC SMD
IC7,11,14	031 74HC125	IC SMD (QUAD BUFFER) 74HCT125D-
IC2	031 74HC157	IC SMD (QUAD MPX) 74VHC157-
IC9,16	031 74HC74	IC SMD
IC3	031 AME1117CCGT	IC SMD (REGULATOR)
IC4,13	031 AME8801SEEV	IC SMD (REGULATOR)
IC5	031 SN74CB3Q3305	IC SMD
IC1	031 TMDS341	IC SMD (SWITCH)
Q1,2,6,8,Q10-13	032 2N7002	TRANSISTOR CHIP
Q4,5,7,9	032 KRC107S	TRANSISTOR CHIP
Q3	032 KRC231S	TRANSISTOR CHIP
C1-6	034 AVRL161	VARIATOR DIODE SMD
ZD1-6	034 KDZ6.2V	ZENER DIODE CHIP
D1-6	034 RCLAMP0504M	DIODE EMC
D7,8,9	037 KDS184RTK	DIODE CHIP KDS184RTK
C8,12,14,16,22,32,34,38,46,51,53,C57-62	047 3535104122	CERAMIC CAPACITOR CHIP 0.1uF
CG1-3,C36,37,42,43,44	047 3535104122	CERAMIC CAPACITOR CHIP 0.1uF
C48,49	047 3535222122	CERAMIC CAPACITOR CHIP 20pF
C15,17,33,54	047 ECJ1VG1H102J	CERAMIC CAPACITOR CHIP 0.001uF
C19-21,C23-31,39,56	047 ECJ1VB1H103K	CERAMIC CAPACITOR CHIP 0.01uF
C10,13,14	047 ECFS1A221M	ELECTROLYTIC CAPACITOR SMD 10V220uF
C7	047 ECFS1A471M	ELECTROLYTIC CAPACITOR SMD 10V470uF
C35,52	047 ECFS1C101M	ELECTROLYTIC CAPACITOR SMD 16V100uF
C11	047 ECFS1C100M	ELECTROLYTIC CAPACITOR SMD 16V10uF
C47	047 ECFS1C220M	ELECTROLYTIC CAPACITOR SMD 16V22uF
C45	047 ECFS1E4R7M	ELECTROLYTIC CAPACITOR SMD 25V4.7uF
R13,52,75	055 ERJ3EKF1000V	RESISTOR CHIP 100
R1,2,5,6,28,40,41,44,46,49,57,60-62,65,66,72,77	055 ERJ3EKF1001V	RESISTOR CHIP 1K
R35,42,51,54,56,73,74	055 ERJ3EKF1002V	RESISTOR CHIP 10K
R58	055 ERJ3EKF1003V	RESISTOR CHIP 100K
R11,12	055 ERJ3EKF10R0V	RESISTOR CHIP 10

SYMBOL	PARTS NO.	DESCRIPTION
R48,71	055 ERJ3EKF1801V	RESISTOR CHIP 1.8K
R31,32,36,43,63,67	055 ERJ3EKF2001V	RESISTOR CHIP 2K
R59,64	055 ERJ3EKF3001V	RESISTOR CHIP 3K
R33,34,45,68	055 ERJ3EKF3301V	RESISTOR CHIP 3.3K
R37,38	055 ERJ3EKF3901V	RESISTOR CHIP 3.9K
R29	055 ERJ3EKF4641V	RESISTOR CHIP 4.64K
R14-23,27,47,50,69,70	055 ERJ3EKF4701V	RESISTOR CHIP 4.7K
R30,53,55,76	055 ERJ3EKF4702V	RESISTOR CHIP 47K
R39	055 ERJ3EKF6802V	RESISTOR CHIP 68K
R3,4,7-10,24,26	055 ERJ3GEY0R00V	RESISTOR CHIP 0
CP415	068 B2B-PH-KS	CONNECTOR WAFER 2P
JACK1-3	068 YKF45-7009	HDMI SOCKET
	HEAT SINK ASSEMBLY	
	501 E-1413-B	PCB ASSY
	017 UF3-08A01	HEAT SINKER BOARD
	019 TO-126	MICA SHEET TBM-51W-15 #9524
	019 TO-3P	MICA SHEET TBM-51W-15 #9043
Q115,215,315,415,515	032 C4137-V	TRANSISTOR 2SC4137-V (2008622110)
Q114,214,314,414,514	033 A1386-OPY	TRANSISTOR 2SA1386A-OPY
Q113,213,313,413,513	033 C3519-OPY	TRANSISTOR 2SC3519A-OPY
CP251	034 P43T7D200BW20	POSISTOR
	OTHERS	
	011 UF3-01B00	H/S PANEL H150
	011 FP-612-B	BLACK PANEL ASSY
	011 FP-612-S	SILVER PANEL ASSY
	012 C-4711A03	KNOB 43Φ NO MARK (BLACK)
	012 C-4711A03S	KNOB 43Φ NO MARK (SILVER)
	012 RV4-09A00	PUSH BUTTON 14Φ (BLACK)
	012 RV4-09A01	PUSH BUTTON 14Φ (SILVER)
	012 TB3-18A00	TACT BUTTON 16 KEY (BLACK)
	012 TB3-18A01	TACT BUTTON 16 KEY (SILVER)
	014 WH3-03A00	UPPER COVER
	019 4TSH-19#2	PLASTIC FOOT 50Φ (BLACK)
	019 C-4714A00	POWER KNOB RING 14Φ (BLACK)
	019 C-4714A01	POWER KNOB RING 14Φ (SILVER)
	019 PR4-12B00	KNOB RING(RED) 46Φ
	019 PR4-12B01	KNOB RING(BLU) 46Φ
	021 RLA172A00	AM LOOP ANT
	022 T-1097U02	POWER TRANSFORMER
(CP105)*	034 SEL1124R	LED (RED) 1X5
(CP105)*	034 SEL1E24W	LED (BLUE) 1X5
	061C-4838A00	ROCKER SWITCH SR1N6BB
	069 C-4629A01	AC 2P INLET 6102.3100 (WIRING)
	072 4TR-3228	T TYPE ANTENNA (FM)
	072 C-4621A03	AC CORD SET SJT for USA
	072 C-4622A02	AC CORD SET for AUSTRALIA
	072 C-4623A02	AC CORD SET for UK
	072 C-4624A03	AC CORD SET for EUROPE
	072 C-4786A01	COMPUTER I/O CABLE (6-P)
CNT100	072 C-4863A01	FLAT CABLE 17P 200mm
	081 WH3-04A00	INSIDE CARTON
	081 WH3-05A00	SHIPPING CARTON
	081 ZE-208	ETHAFOAM MOULDING
	092 RR-1060	REMOTE UNIT
	082 OMRSX-1057	OWNERS MANUAL

Addendum List for Black and Silver

RSX1057

SYMBOL	PARTS	DESCRIPTION
①	011 FP-612-B	BLACK PANEL ASSY
②	011 FP-612-S	SILVER PANEL ASSY
③	011 UF3-01B00	H/S PANEL H150
	012 C-4711A03	KNOB 43F NO MARK (BLK)
	012 C-4711A03S	KNOB 43F NO MARK (SLV)
	012 RV4-09A00	PUSH BUTTON 14F (BLK)
	012 RV4-09A01	PUSH BUTTON 14F (SLV)
	012 TB3-18A00	TACT BUTTON 16 KEY (BLK)
	012 TB3-18A01	TACT BUTTON 16 KEY (SLV)
	034 SEL1124R	LED (RED) 1X5
	034 SEL1E24W	LED (BLU) 1X5

Panel Assy is included:
 Panel Window
 Side Cap
 Knob Ring
 Tact buttons
 LED

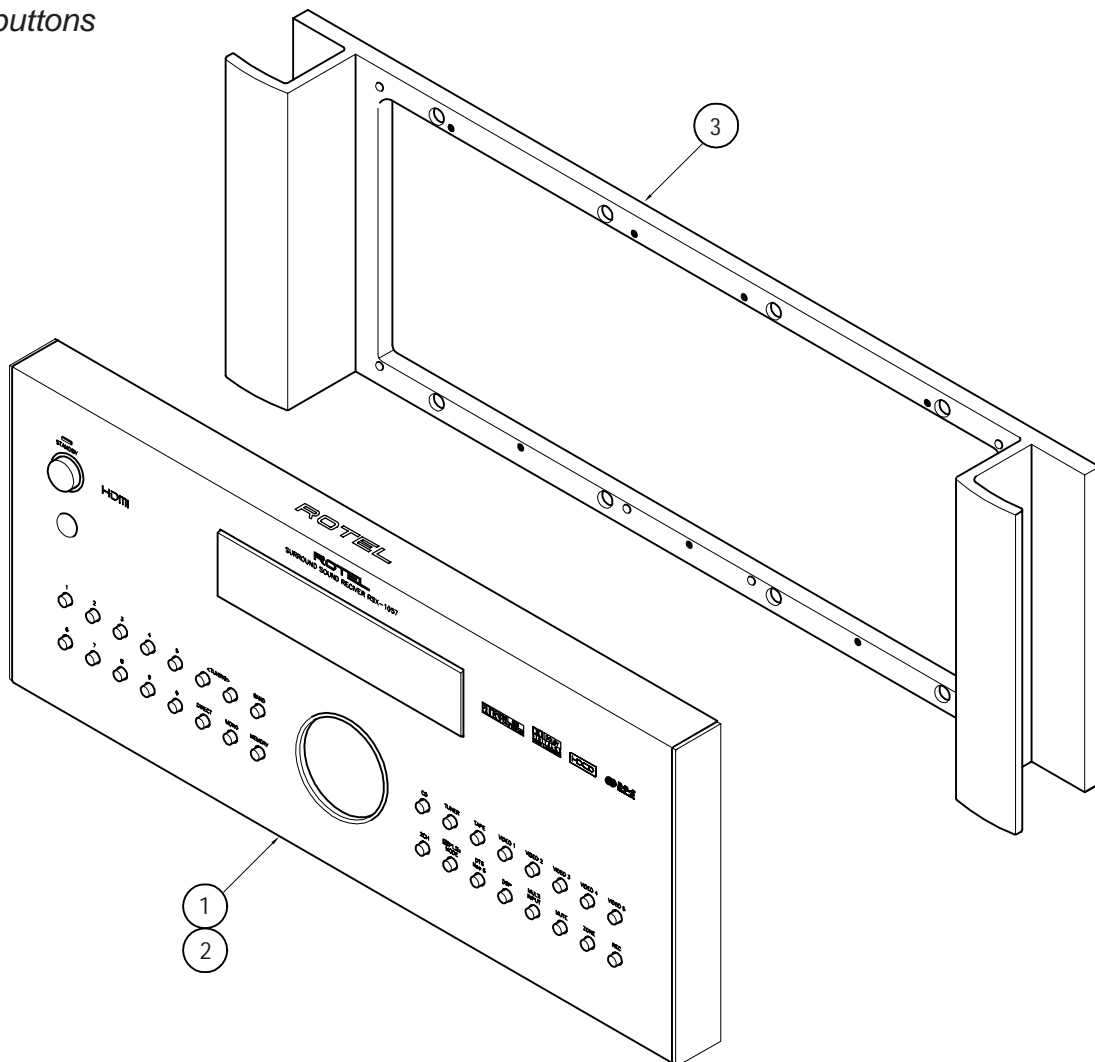

Adjustment

Instruments : DC milli-voltmeter

Notes : Prior to Bias Adjustment, run about 5minutes with rated output(8ohms) and warm up Power Transistor and Heat Sink. Set input off.

Step	Coupling	Location	Adjust	Adjust for
1	ONE SIDE OF R541	E-1413 PCB	VR501	DC milli-voltmeter reads 4mV
2	ONE SIDE OF R141	E-1413 PCB	VR101	
3	ONE SIDE OF R341	E-1413 PCB	VR301	
4	ONE SIDE OF R441	E-1413 PCB	VR401	
5	ONE SIDE OF R241	E-1413 PCB	VR201	

<MEMO>

1. Light-up ALL FL segments to check:

Press "2CH" and "MUTE" of front panel while turn on the rear panel master power switch. When release the lighting, press STANDBY switch or master power switch.

RSX-1057 Main Software Upgrade Procedure

Install the "Main FlashUp" program which is provided by ROTEL in the computer. And connect RS232 Cable with DB-9 to RJ45 terminations.

1. Click "Open File" -> Select Upgrade file



2. Confirm Port and Baud Rate setting. Then, click "Next" button. (ref: RSX-1057 Baud Rate is 19200)

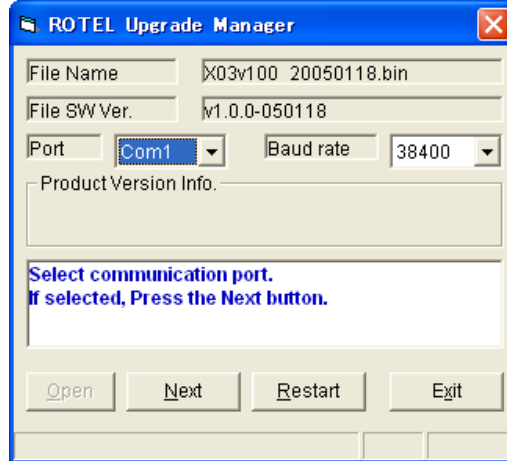

3. Communication port initializing Wait. Then, click "Next" button.

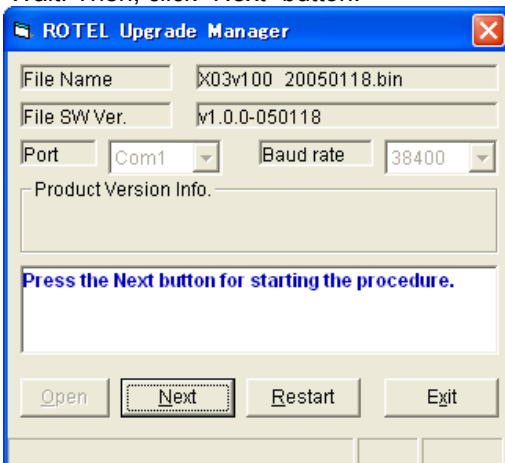

4. Power off the main switch of rear. And on again.

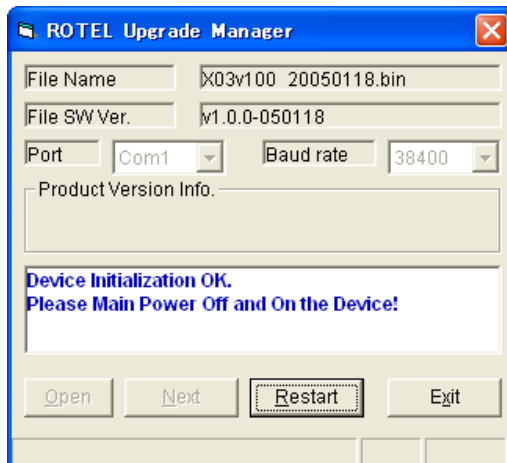

5. Click "Next" button.

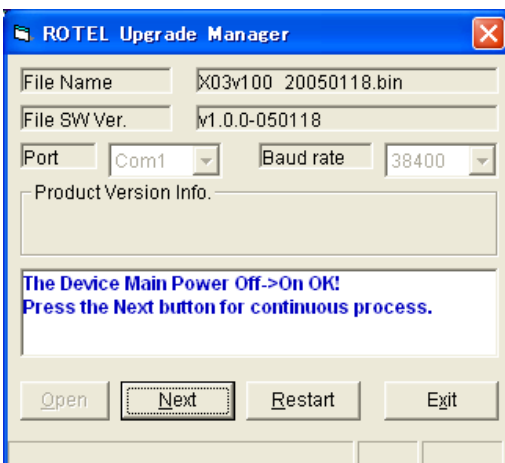

6. The device's current version is displayed. Click "Next" button.

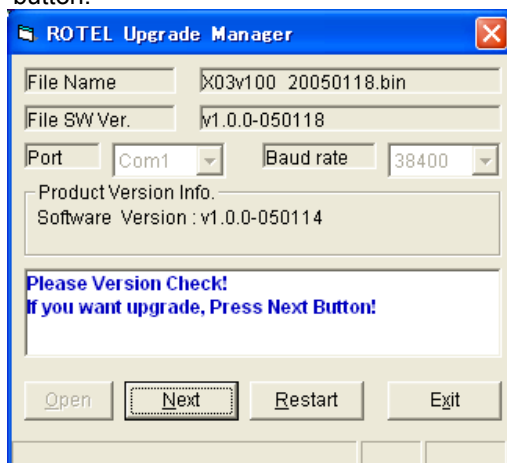

7. The sector is erasing. Wait a moment.

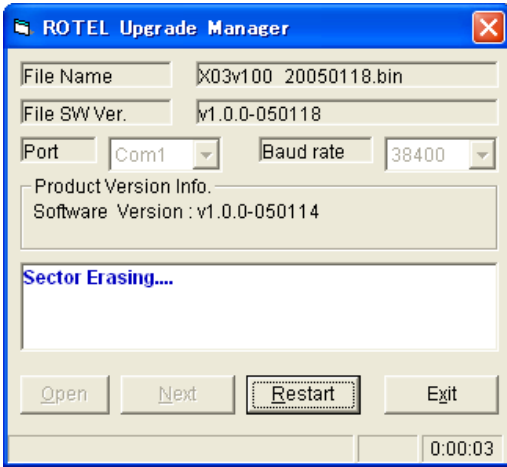

8. The sector is erased. The flash is writing automatically. Wait a while.

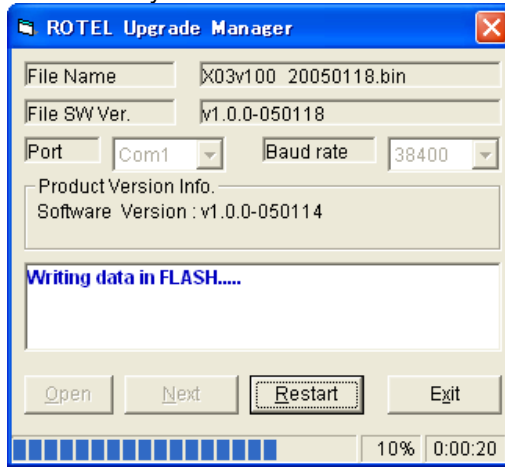

9. If the writing and checksum is OK, wait a next procedure.

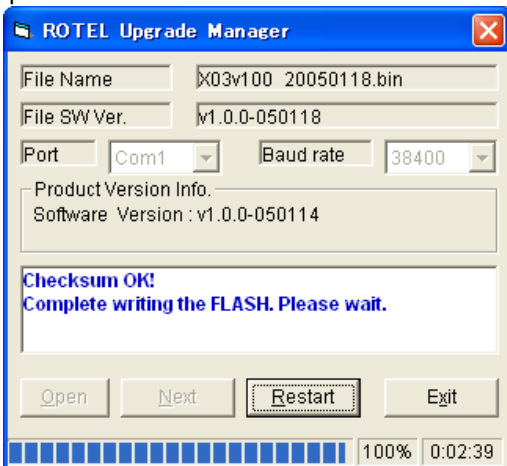

10. Completed all procedure. Power off and on again on main switch of rear. Click "Exit" button to finish the

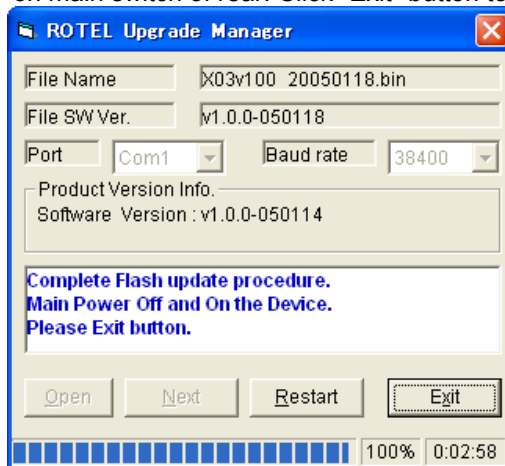

11. Finish.

Wiring Diagram

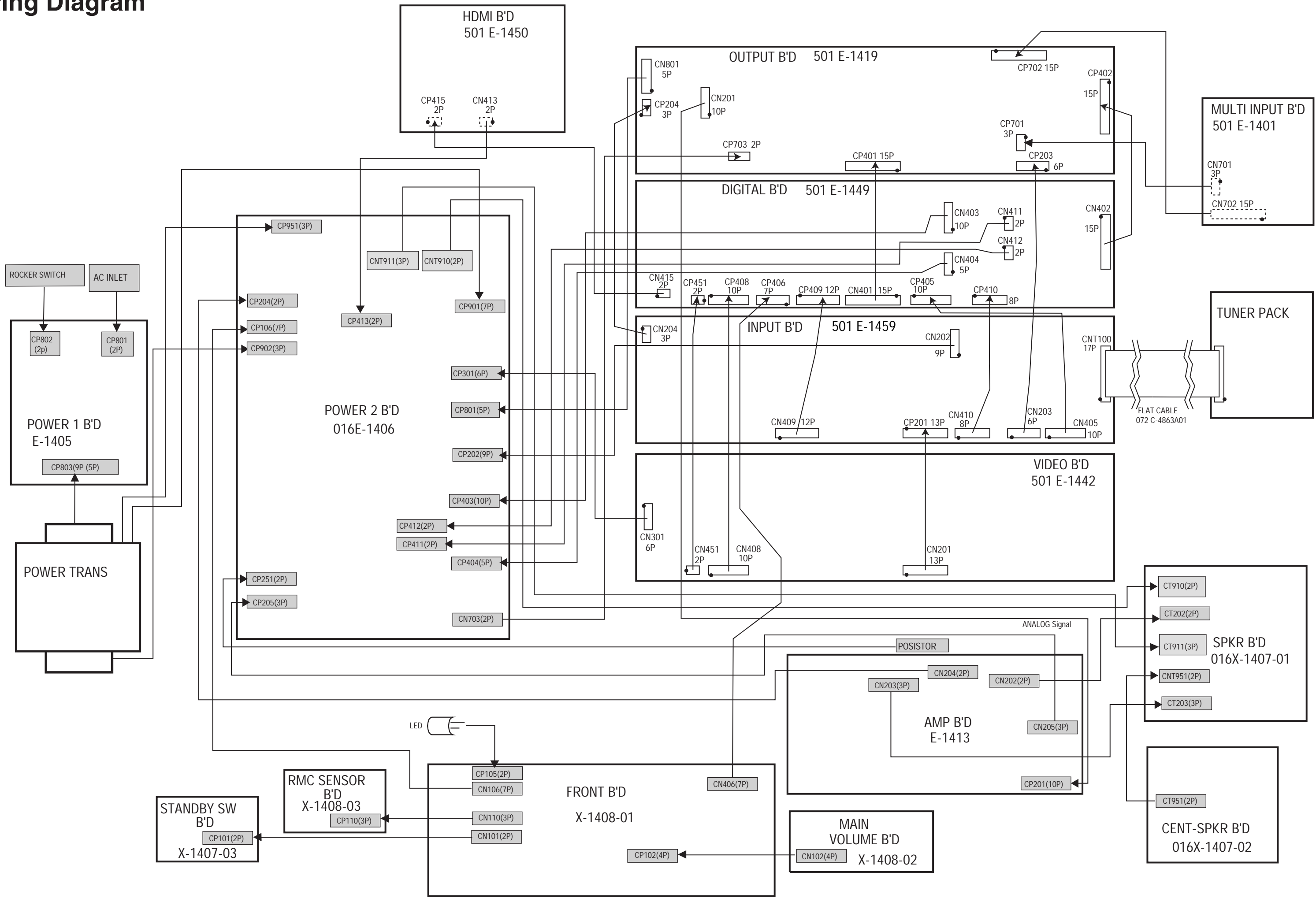

Front PCB 016 X-1408A01~03

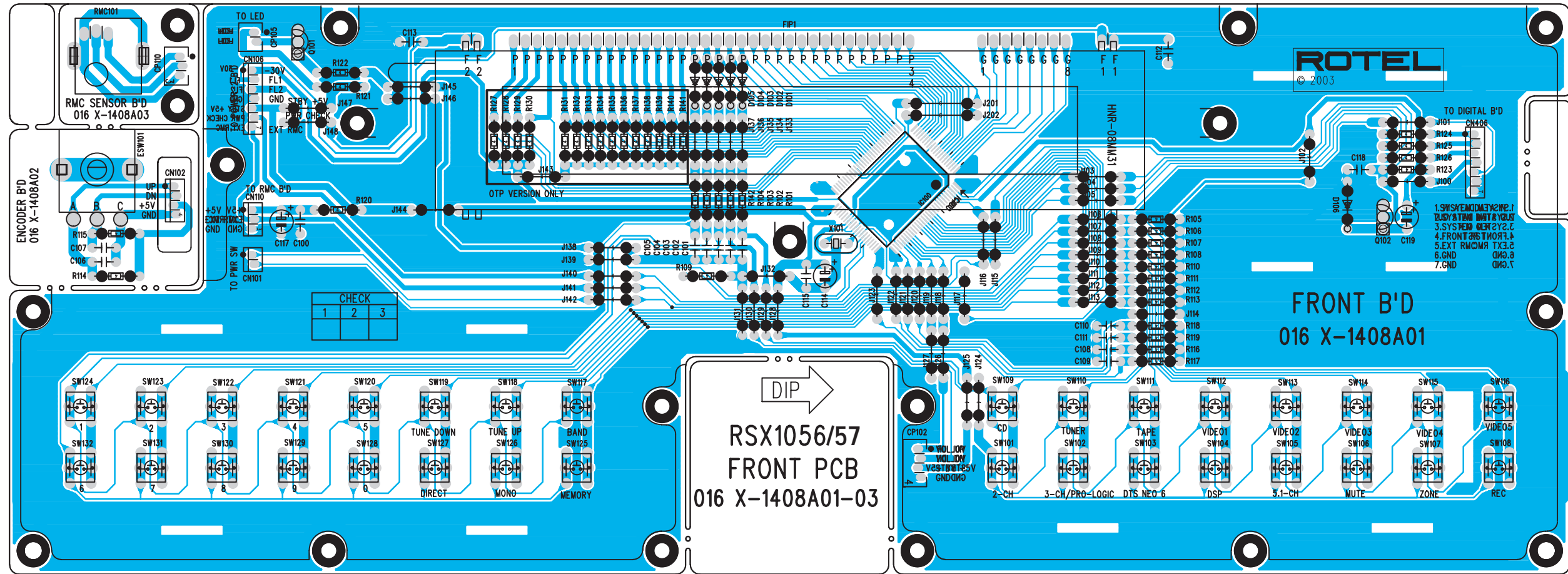

MULTI INPUT PCB 016 E-1401B00

Top View

Bottom View

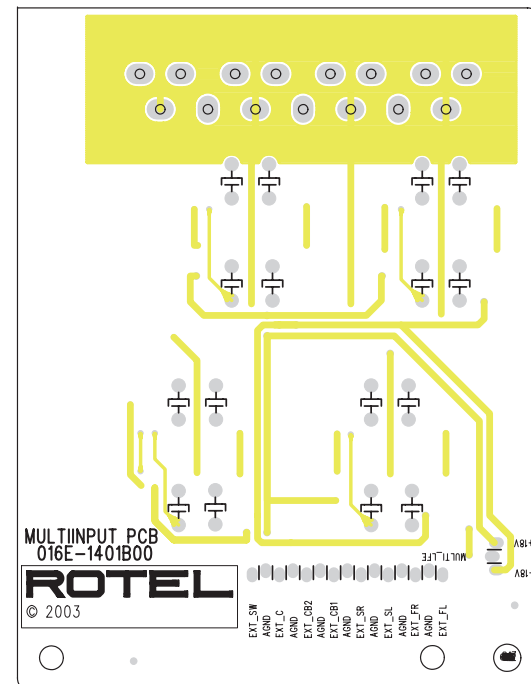
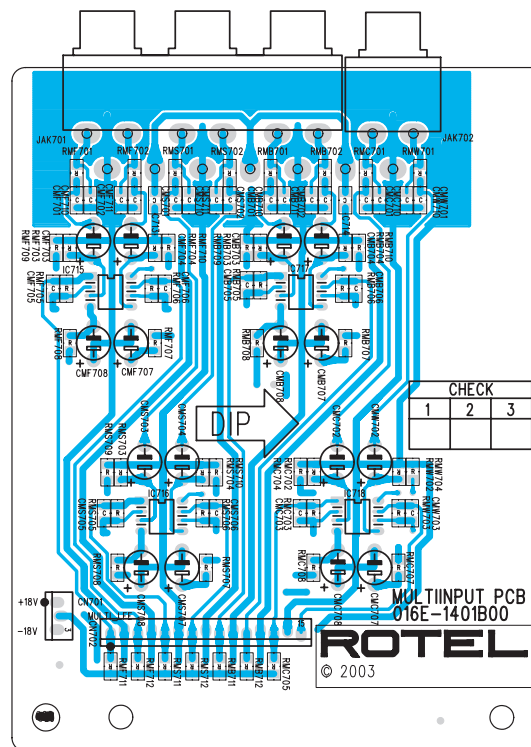

Speaker Terminal PCB 016 X-1407C01~03

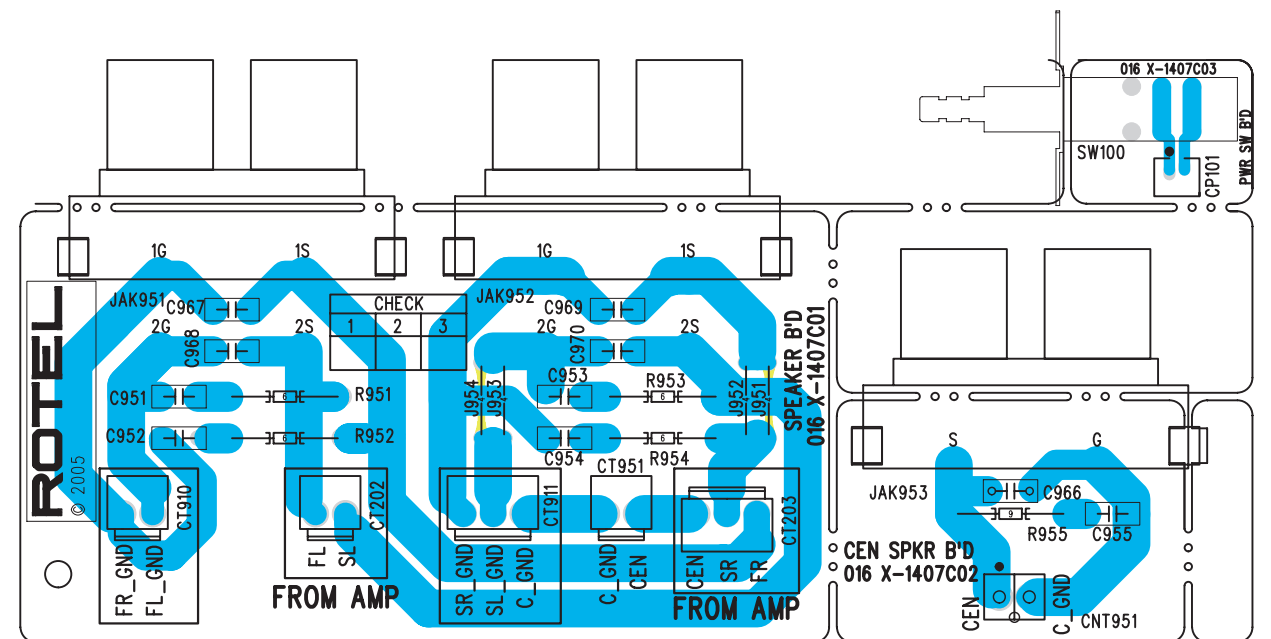

Input PCB 016 E-1459A00

Top View

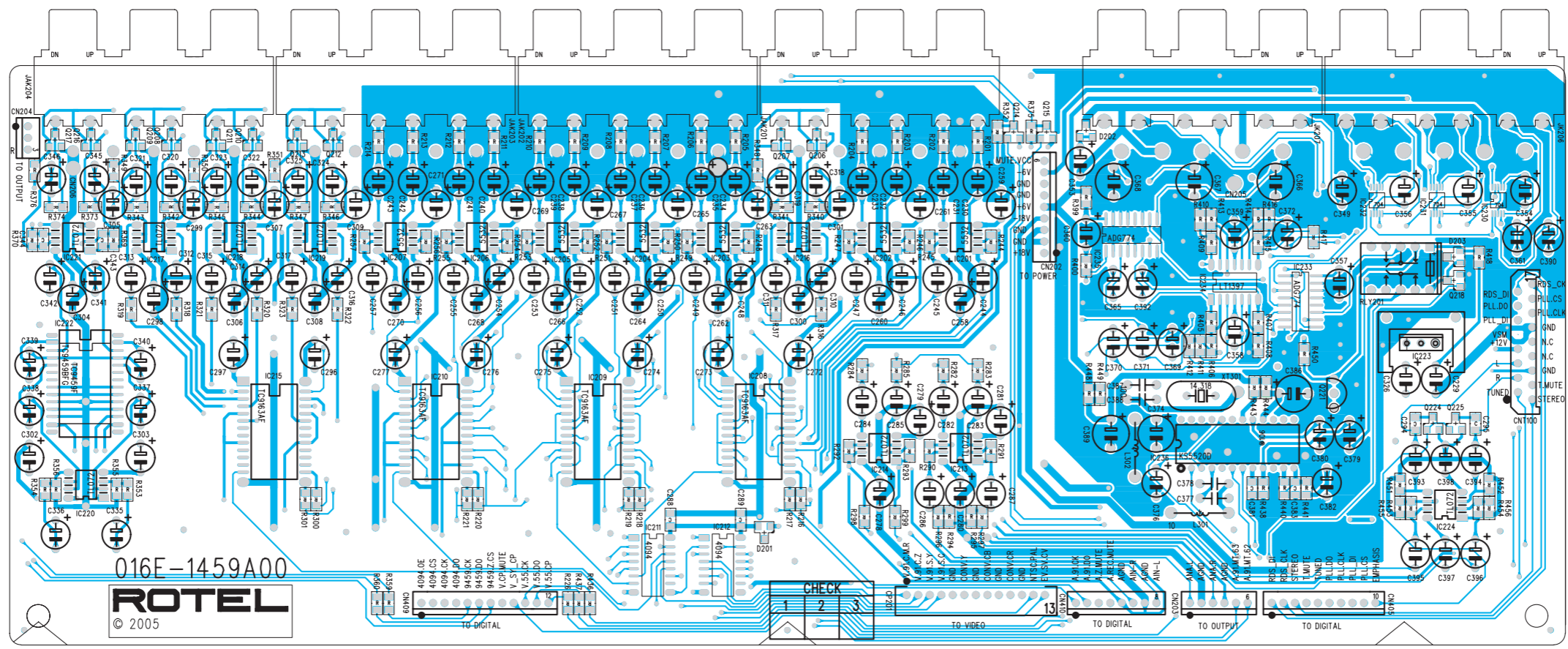

Bottom View

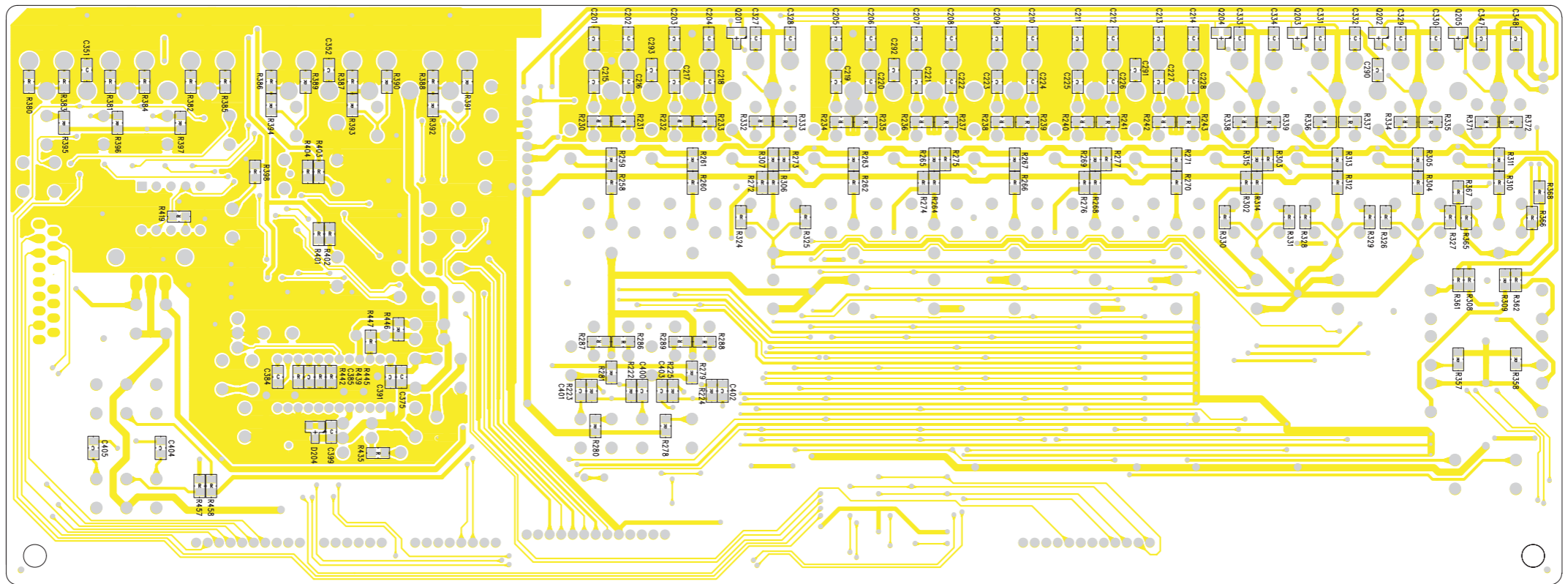

Digital PCB 016 E-1449A00

Top View

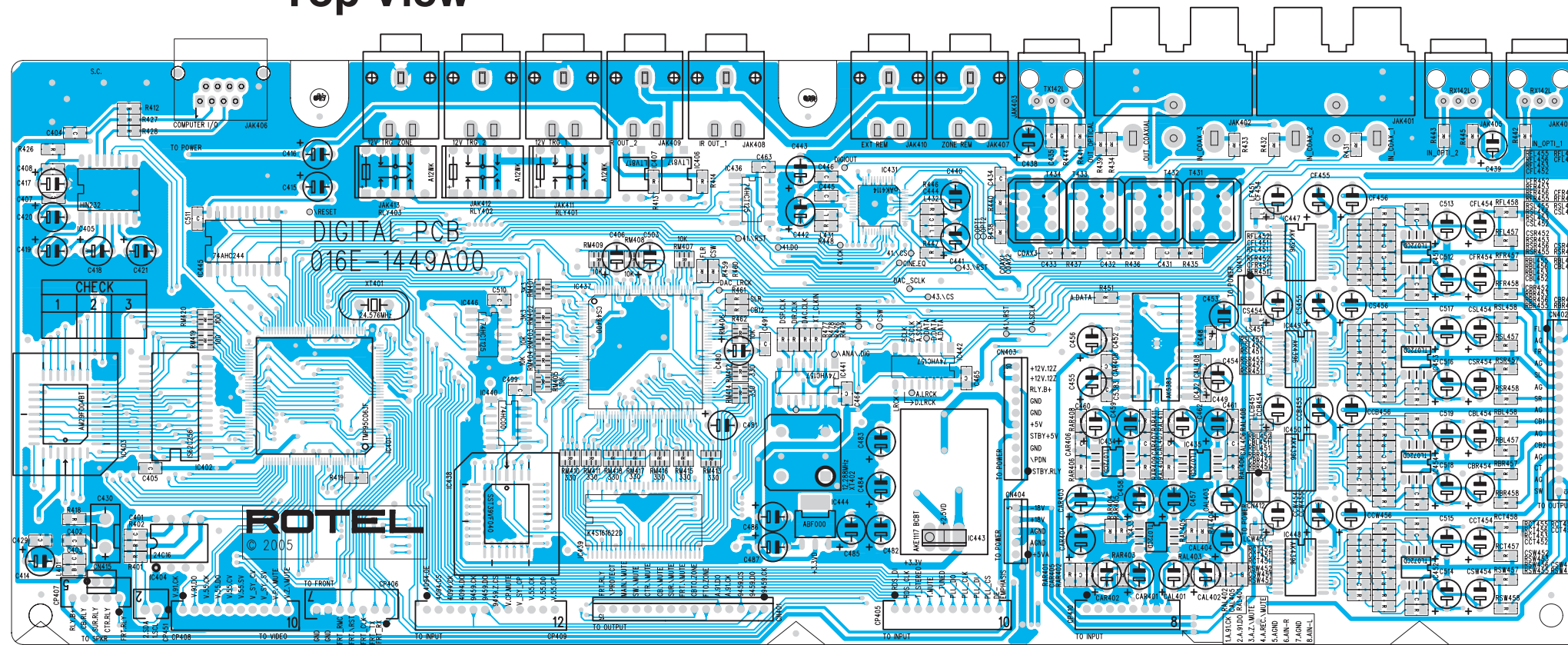

Bottom View

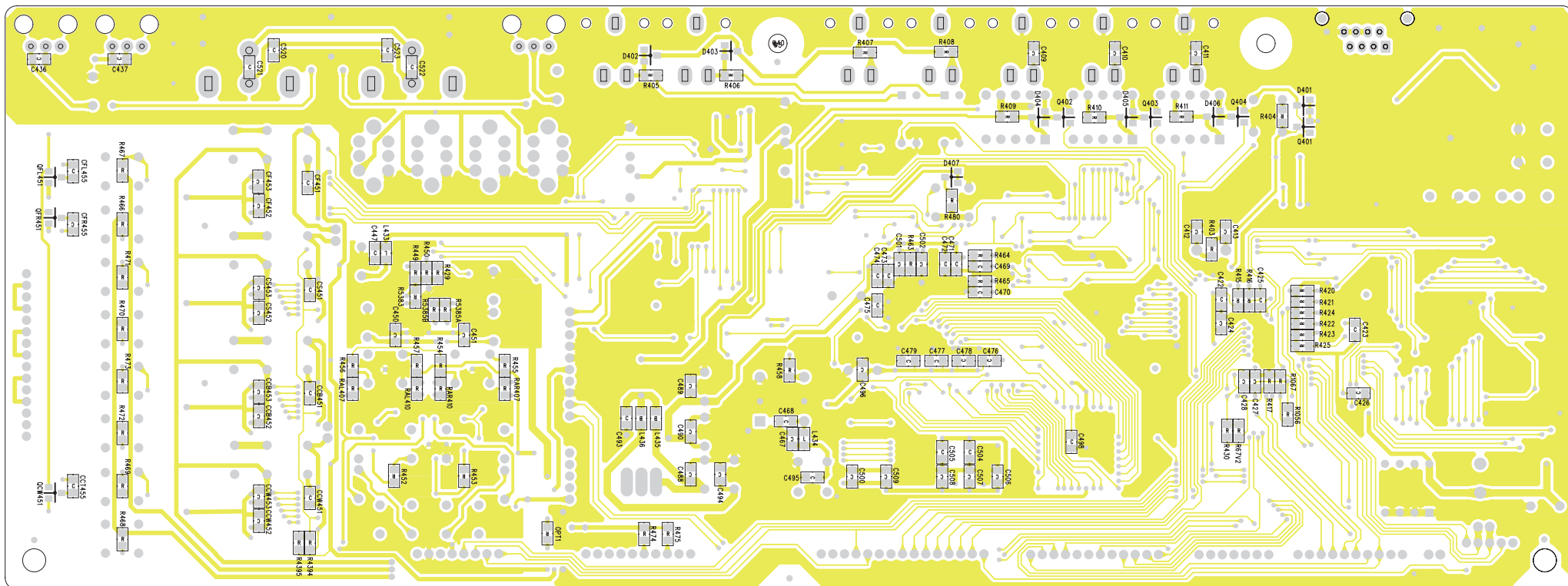

Video PCB 016 E-1442B00

Top View

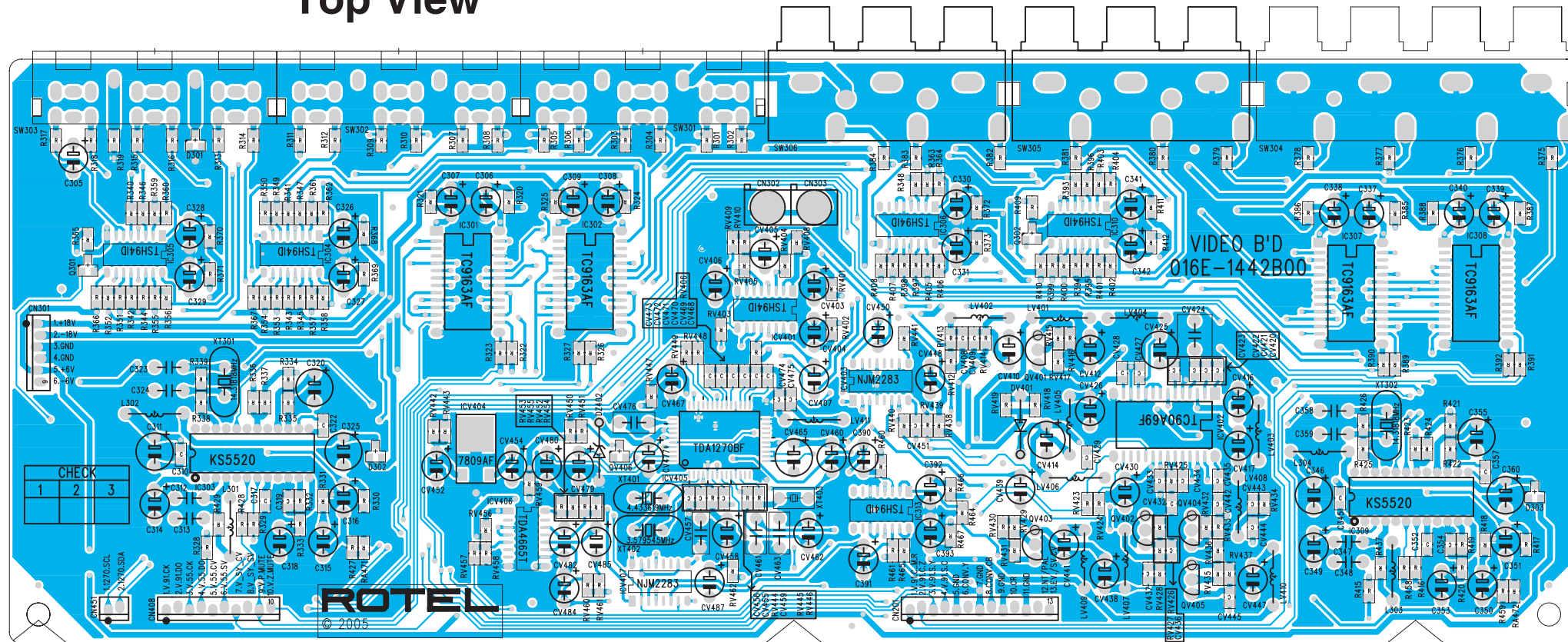

Bottom View

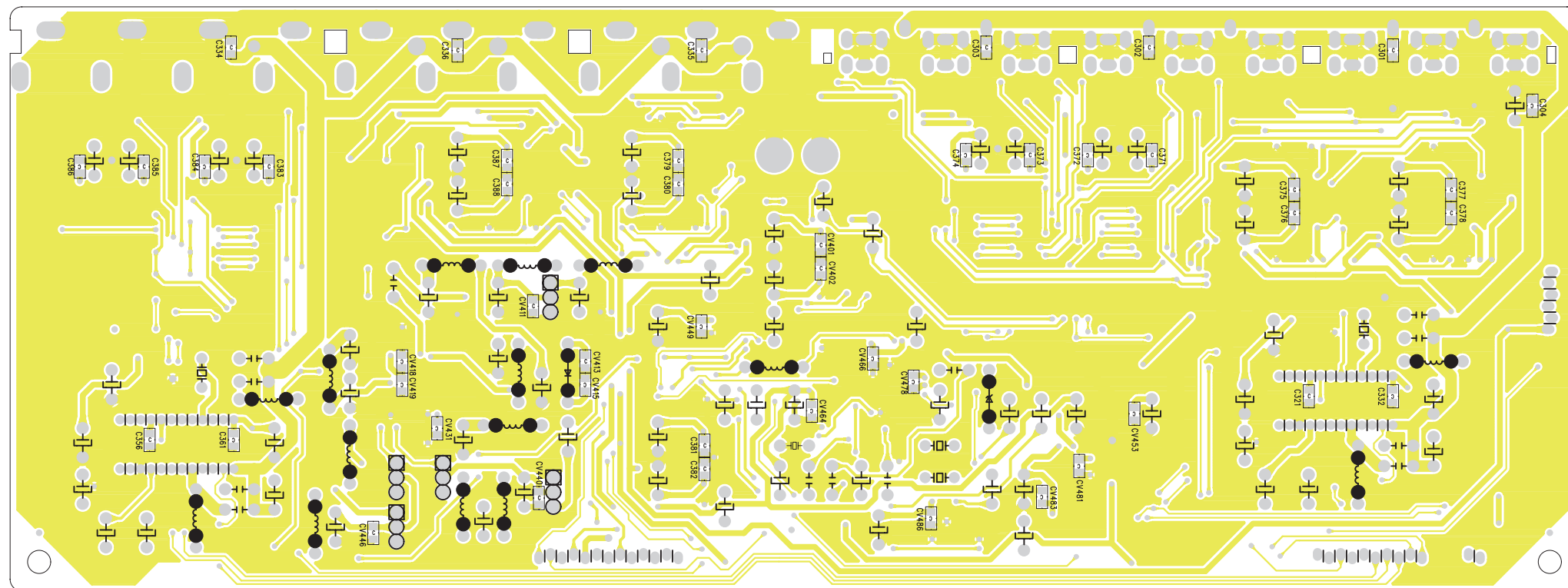

HDMI PCB 016 E-1450G00
Top View

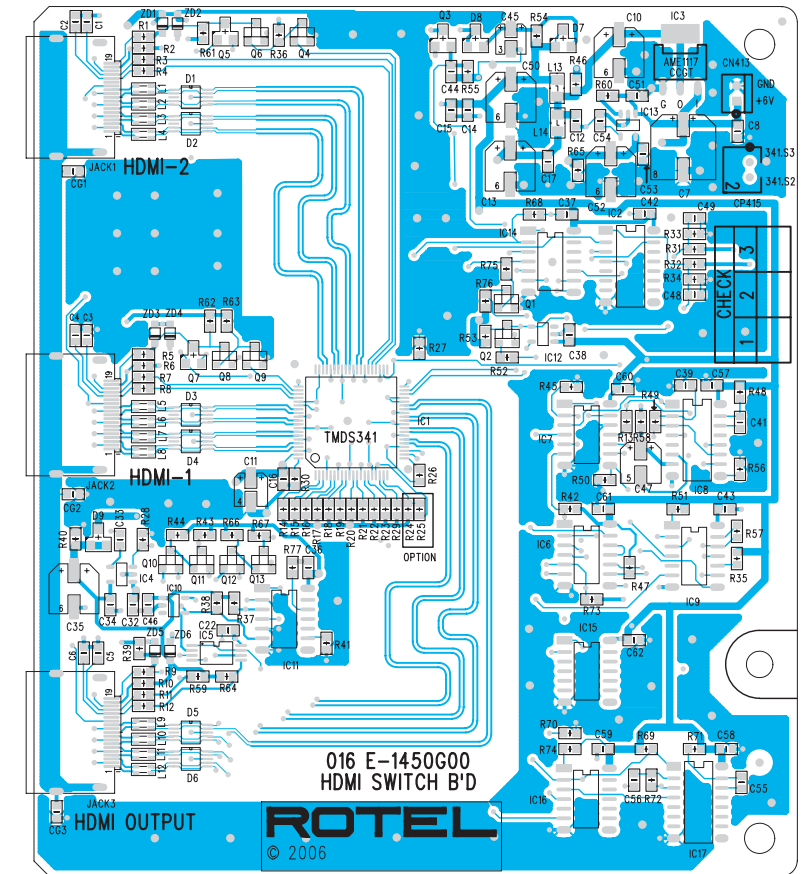

Bottom View

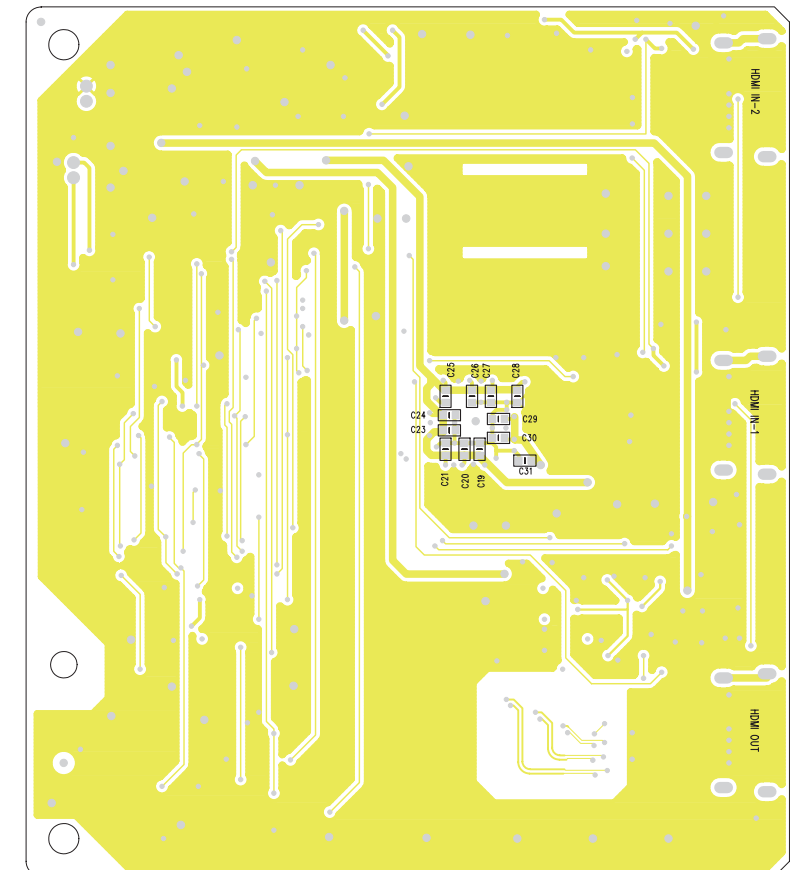

Output PCB 016 E-1419B00

Top View

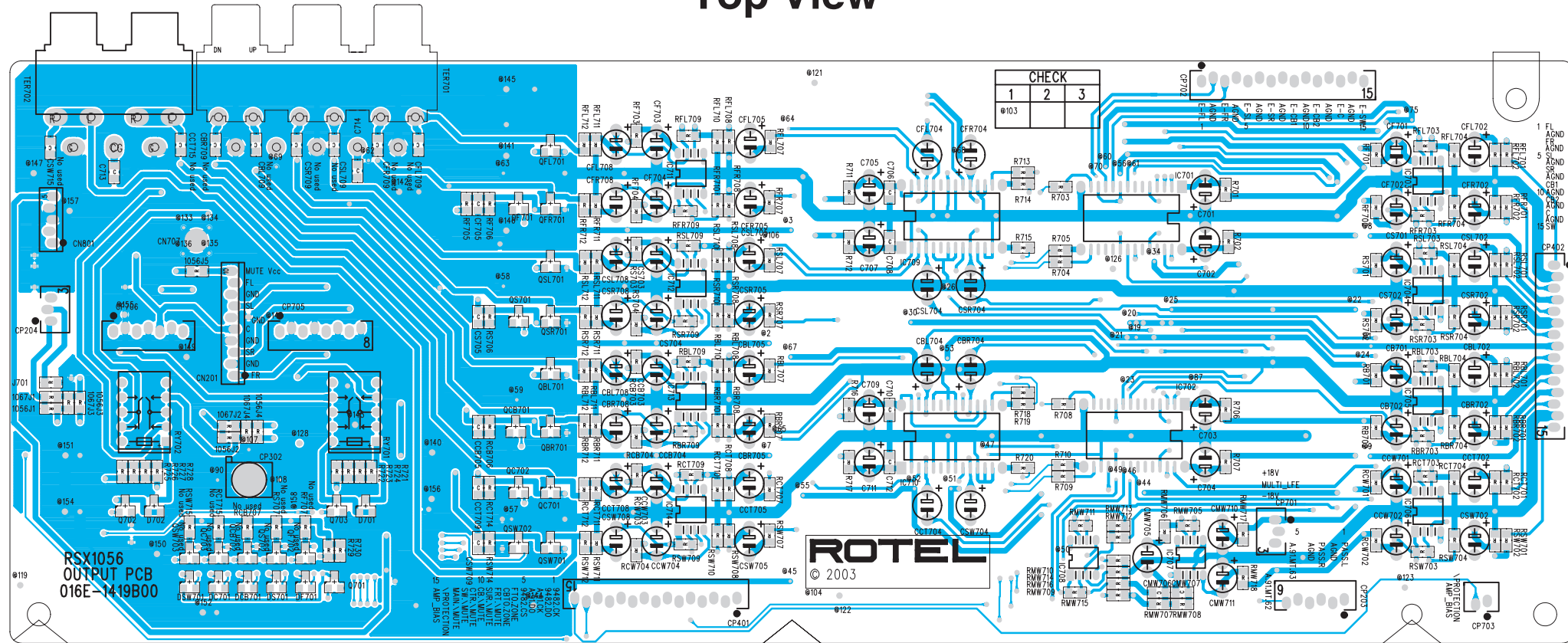

Bottom View

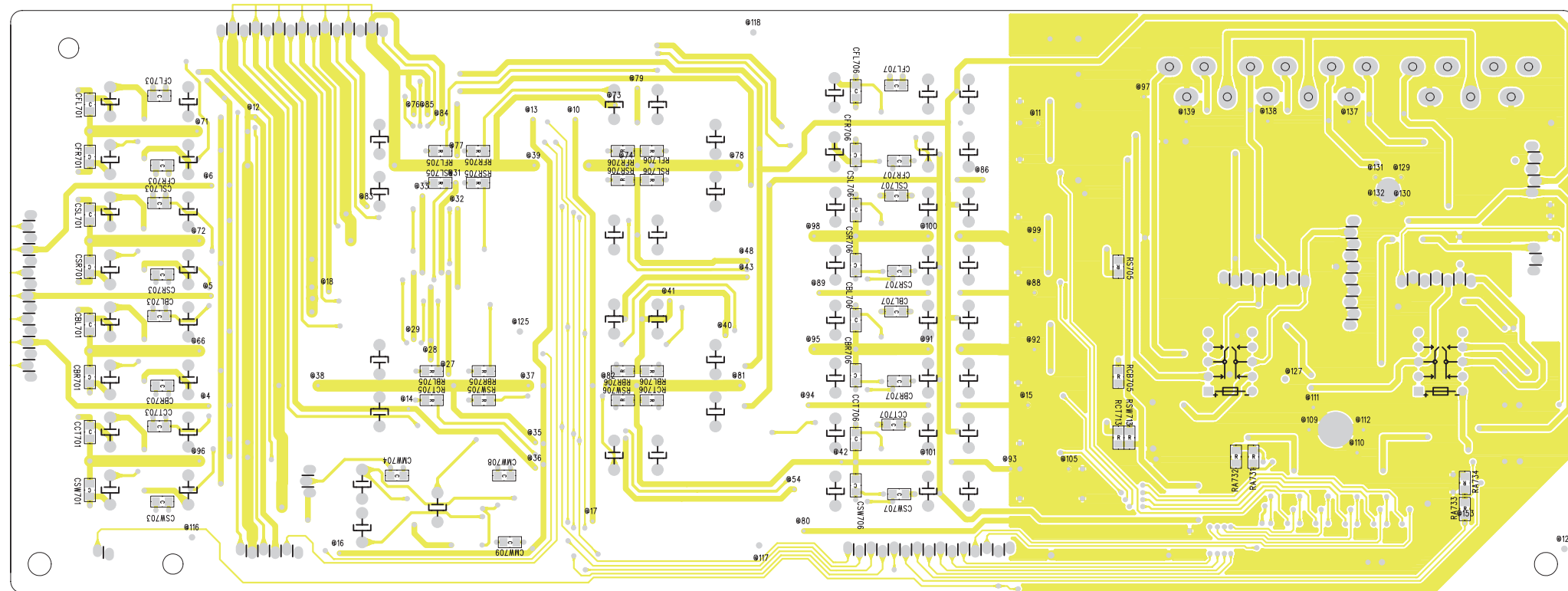

Power Amplifier 016 E-1413B00

TOP VIEW

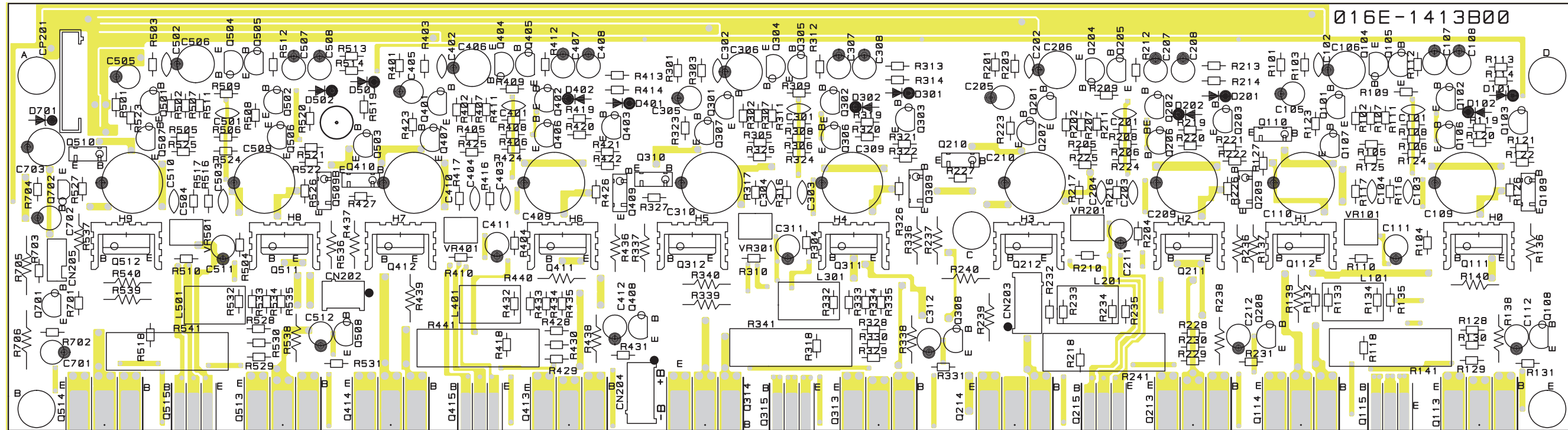

BOTTOM VIEW

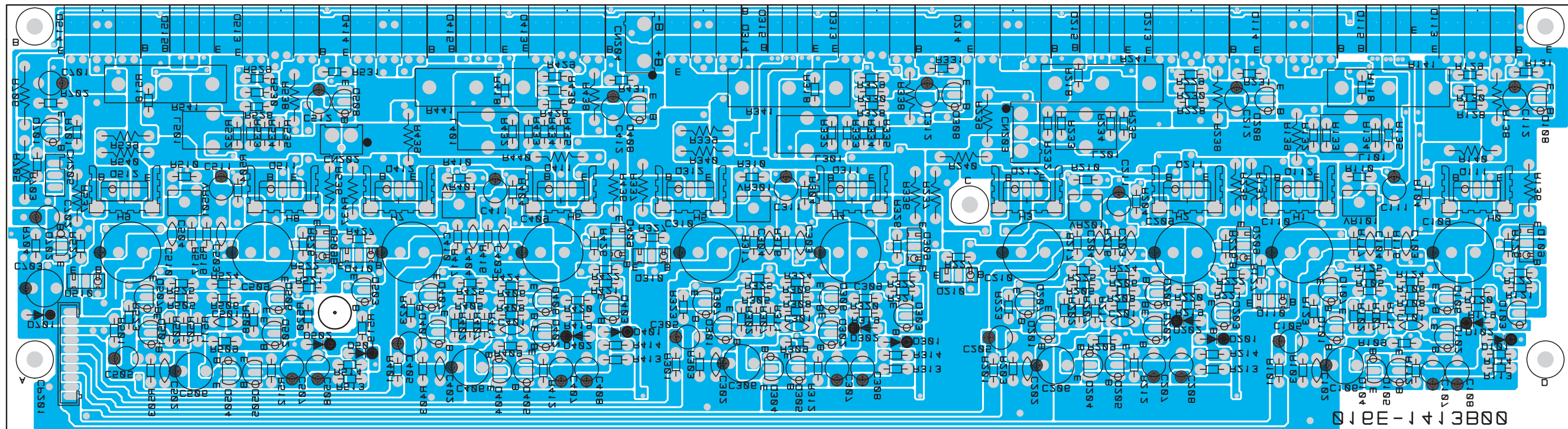

PCB Assembly 7/7

Power-1 PCB 016 E-1405C00

Top View

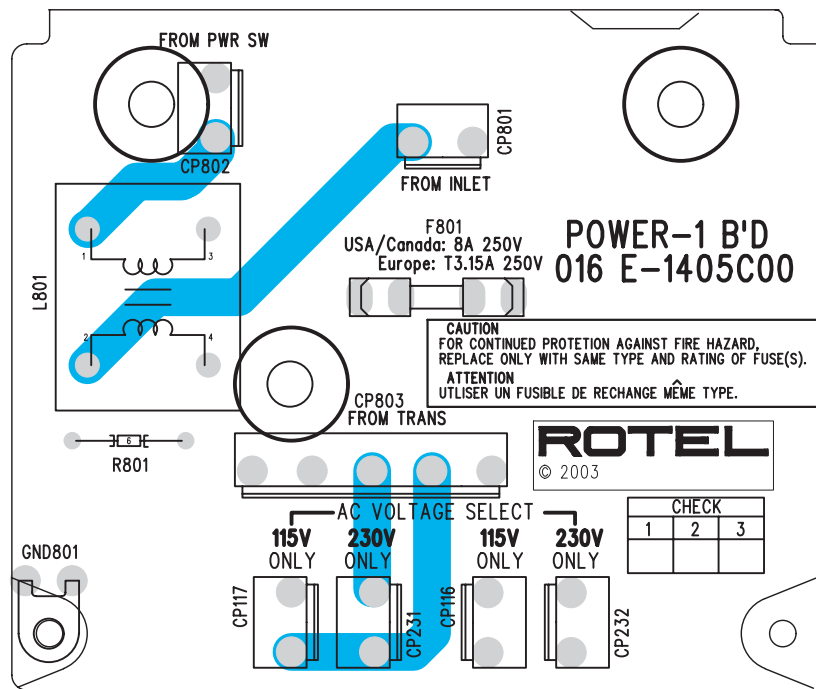

Power-2 PCB 016 E-1406E00

Top View

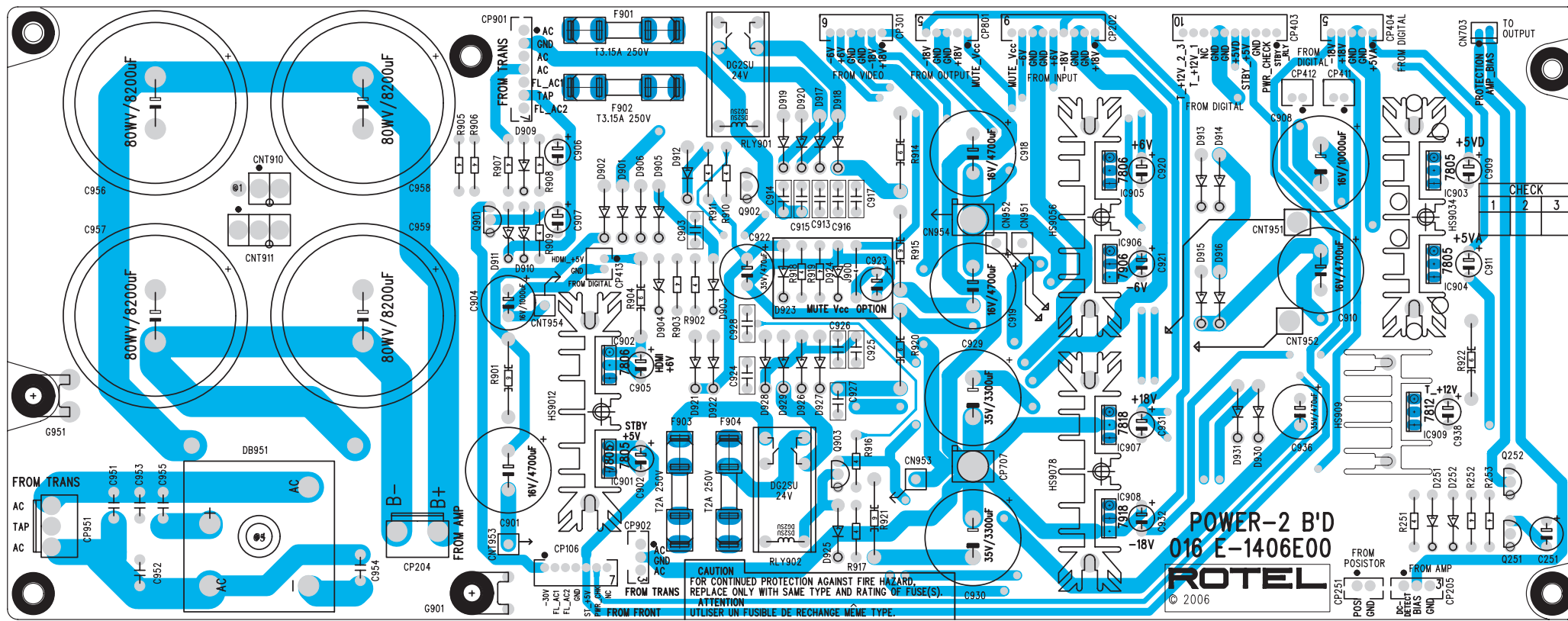

Bottom View

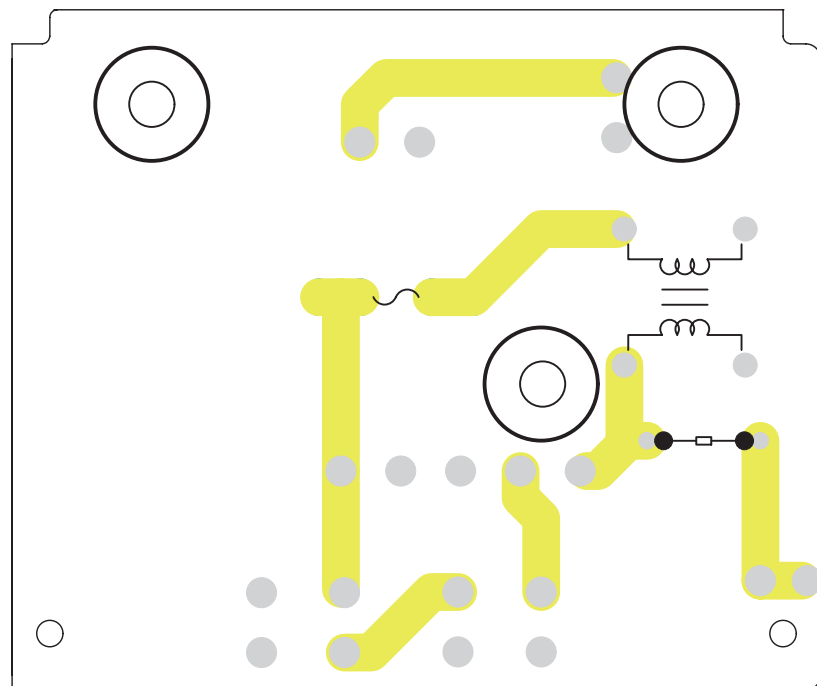

Bottom View

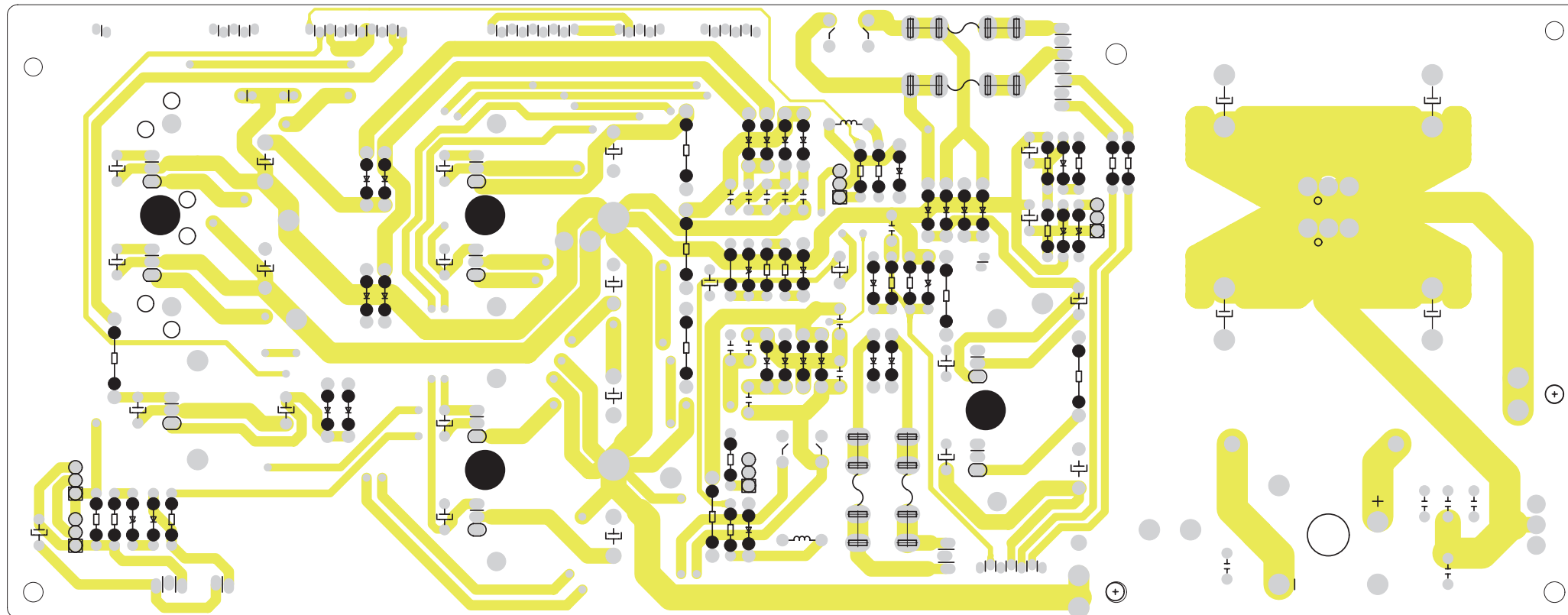

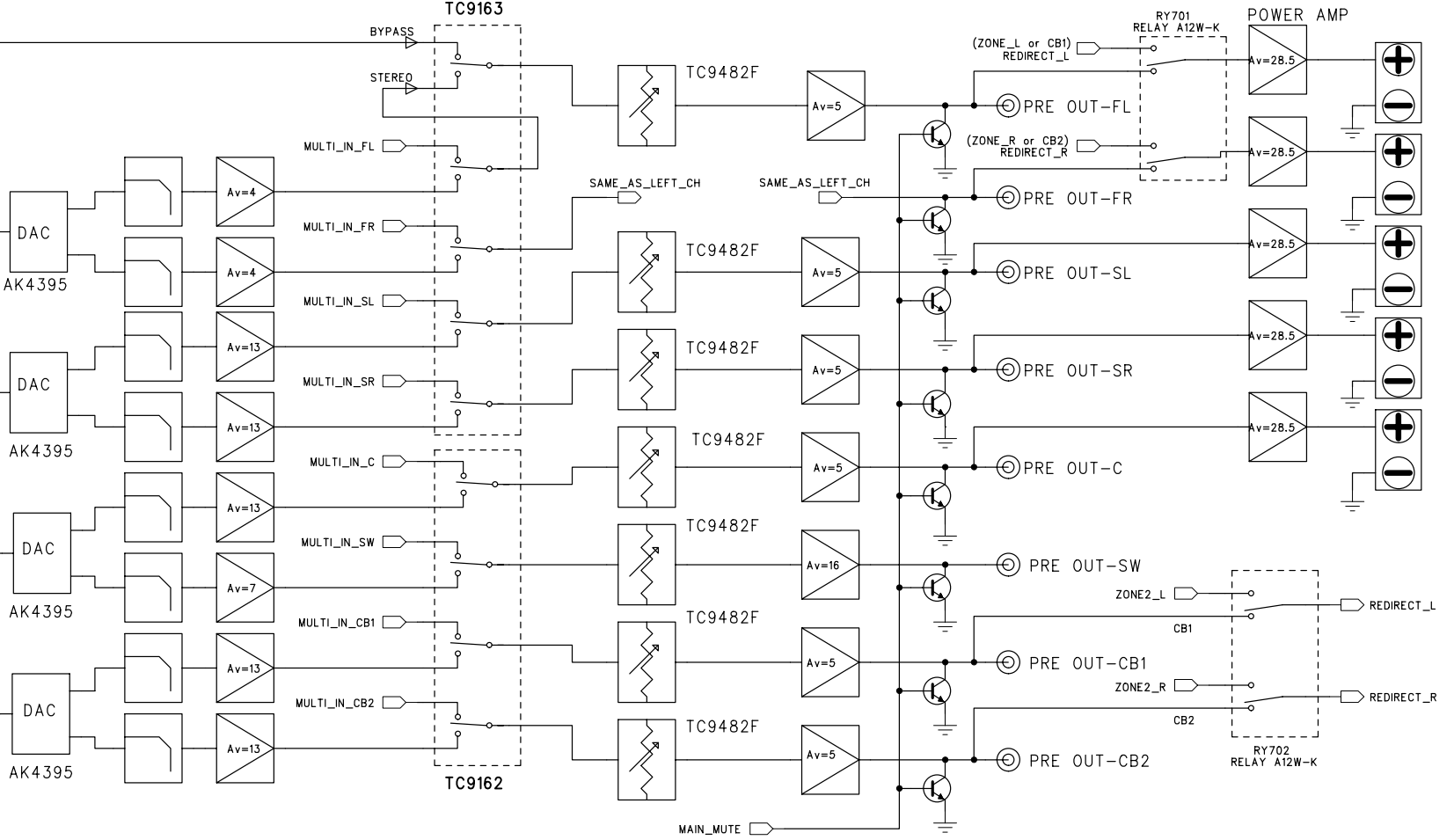
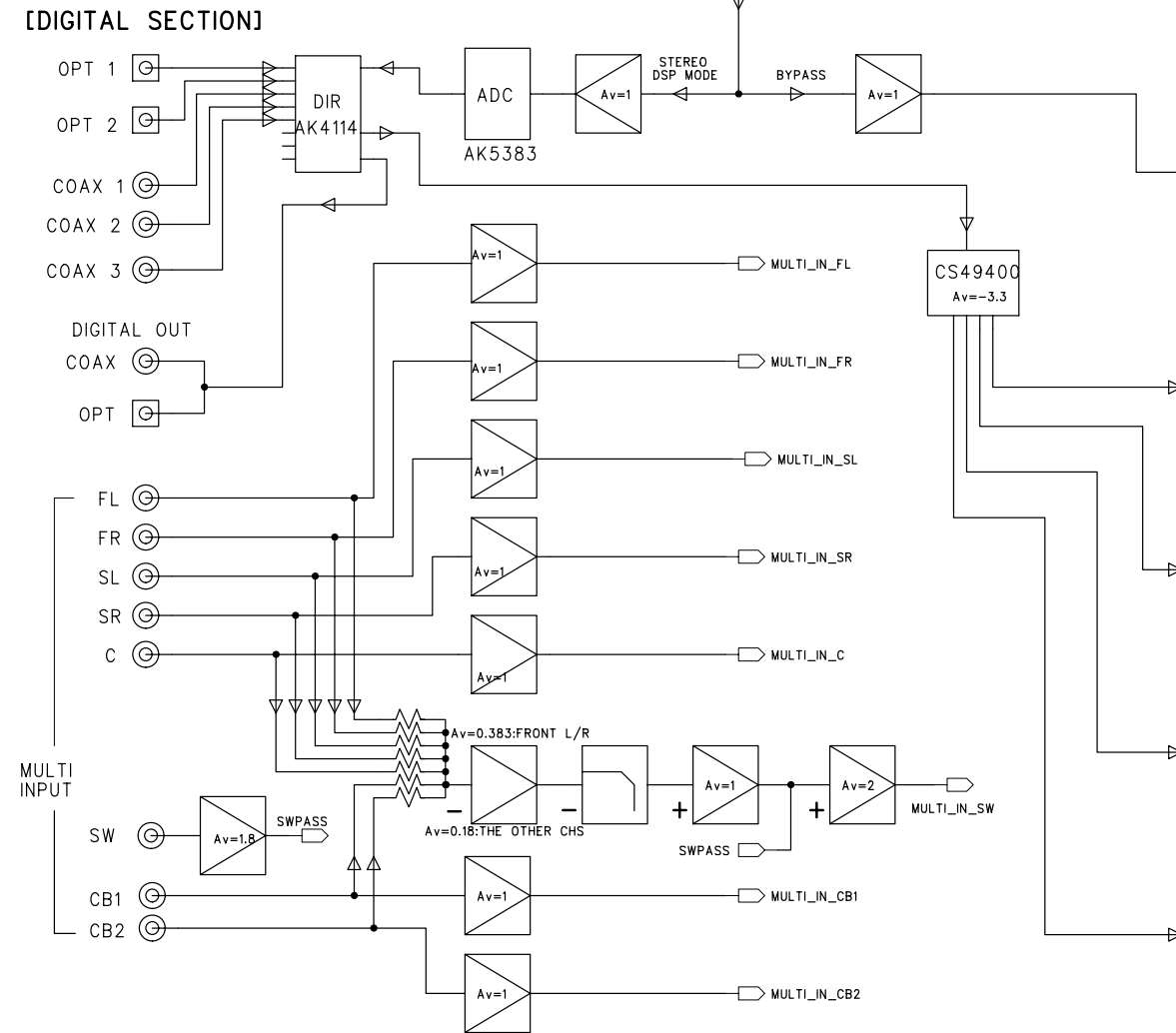
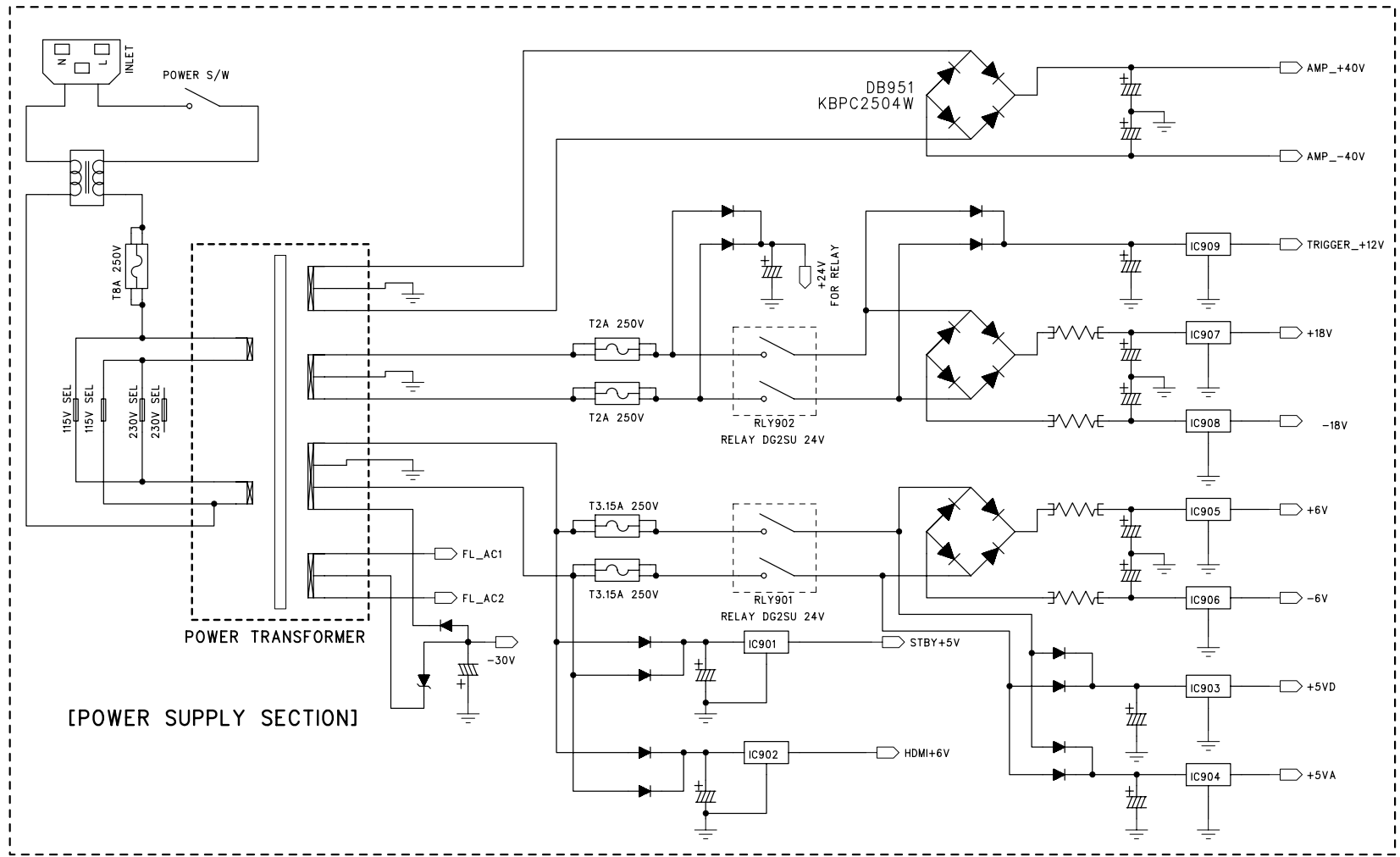
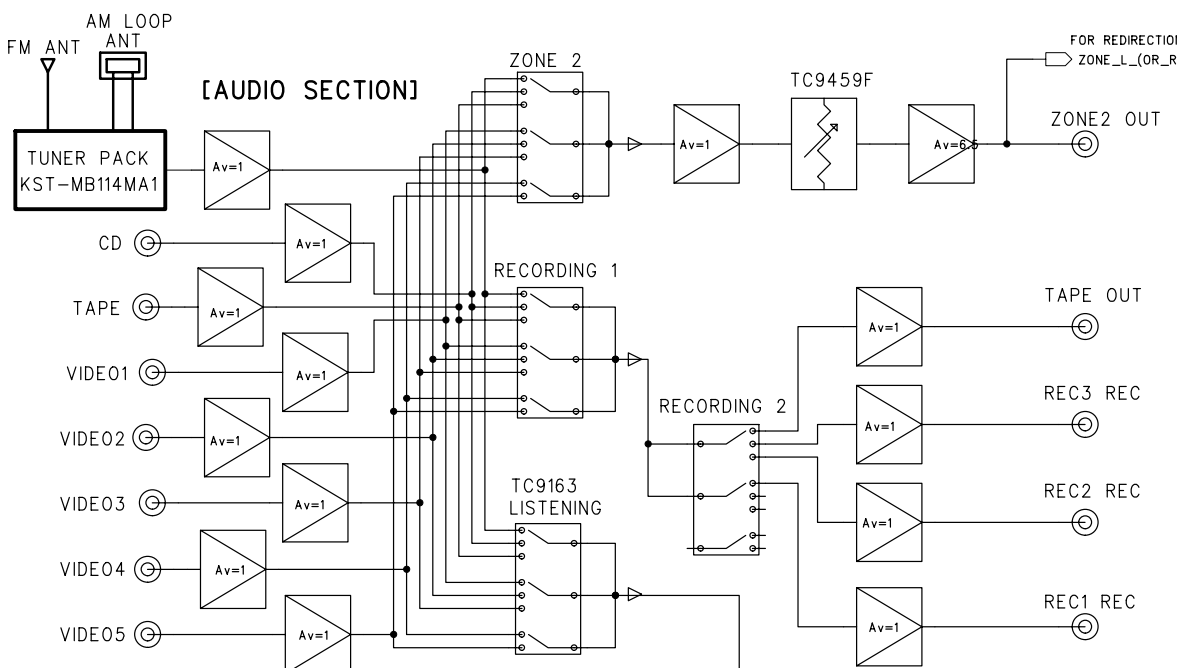

COMPOSITE VIDEO

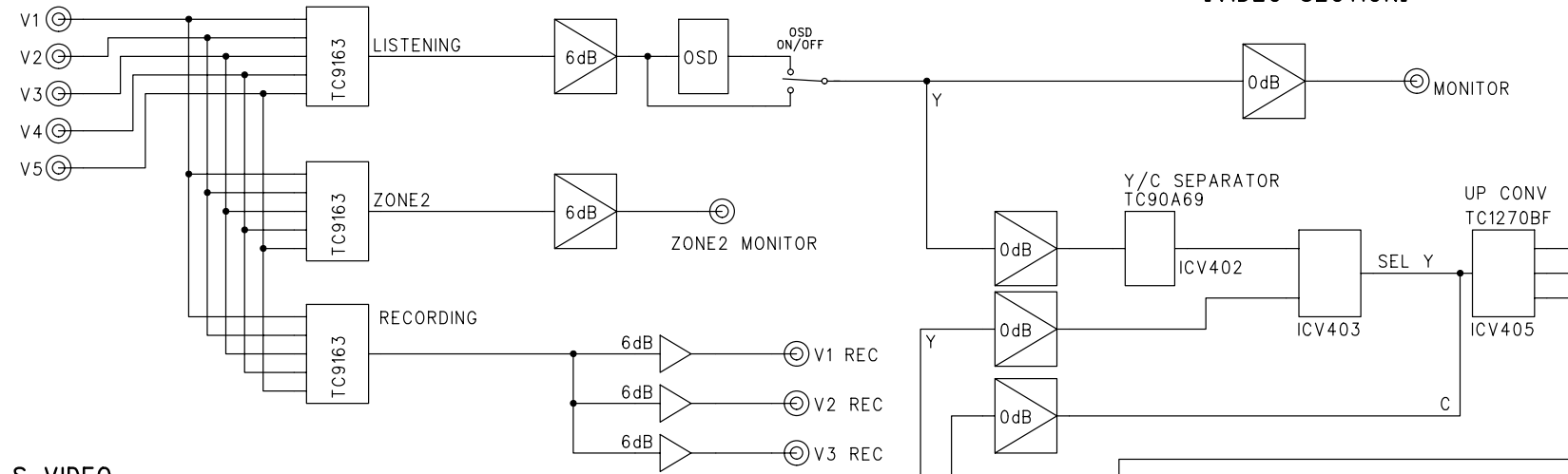

[VIDEO SECTION]

[CONTROL SECTION]

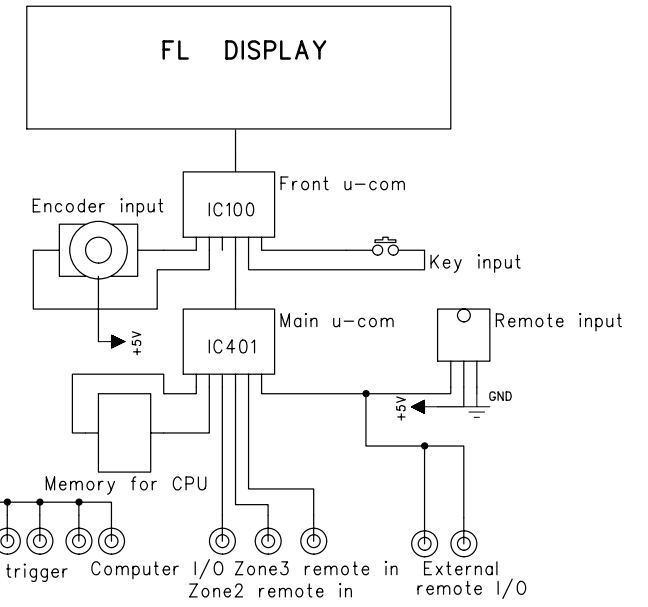

S VIDEO

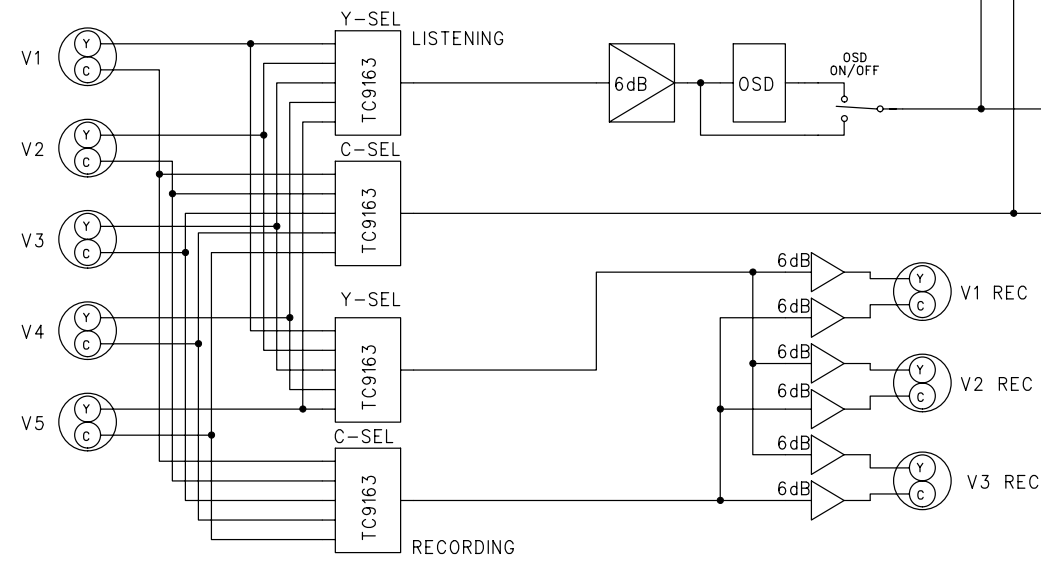

COMPONENT VIDEO

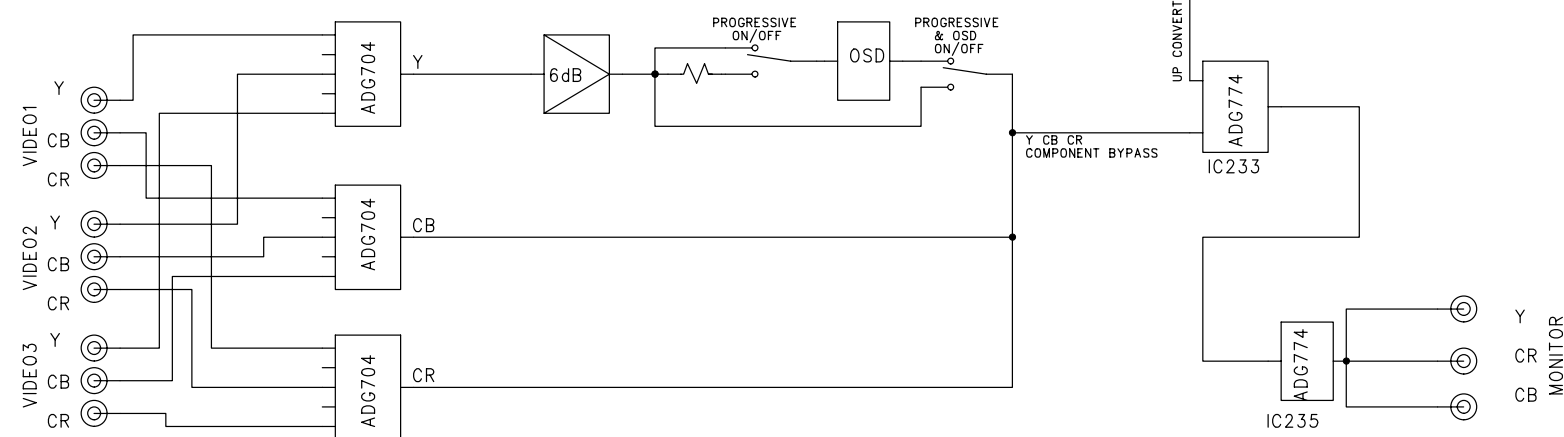

HDMI SWITCH BD

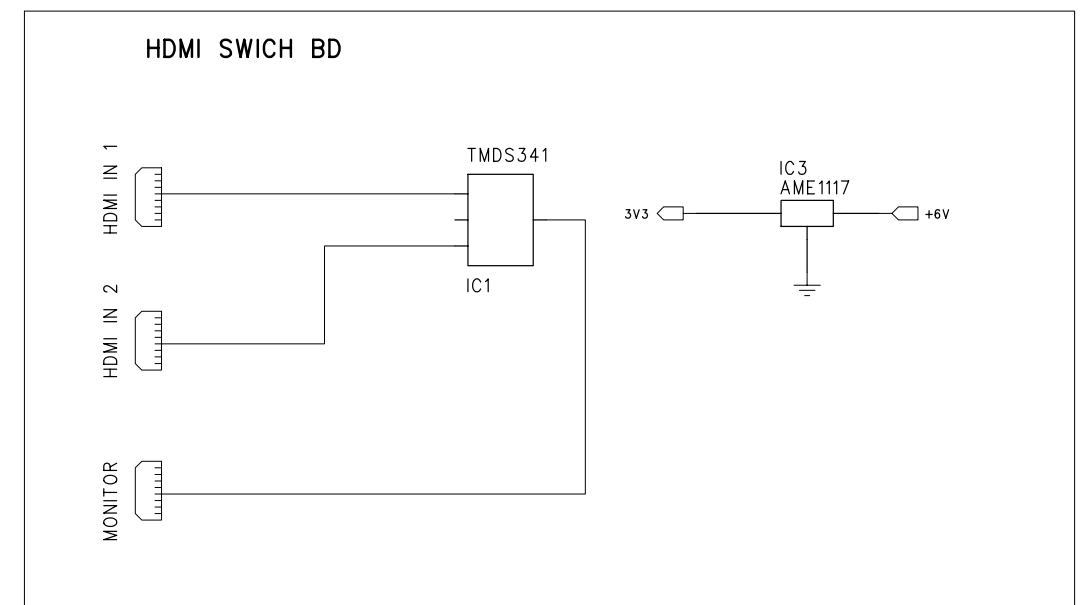

Schematic Diagram 1/13

INPUT (1/3) 016 E-1459A00

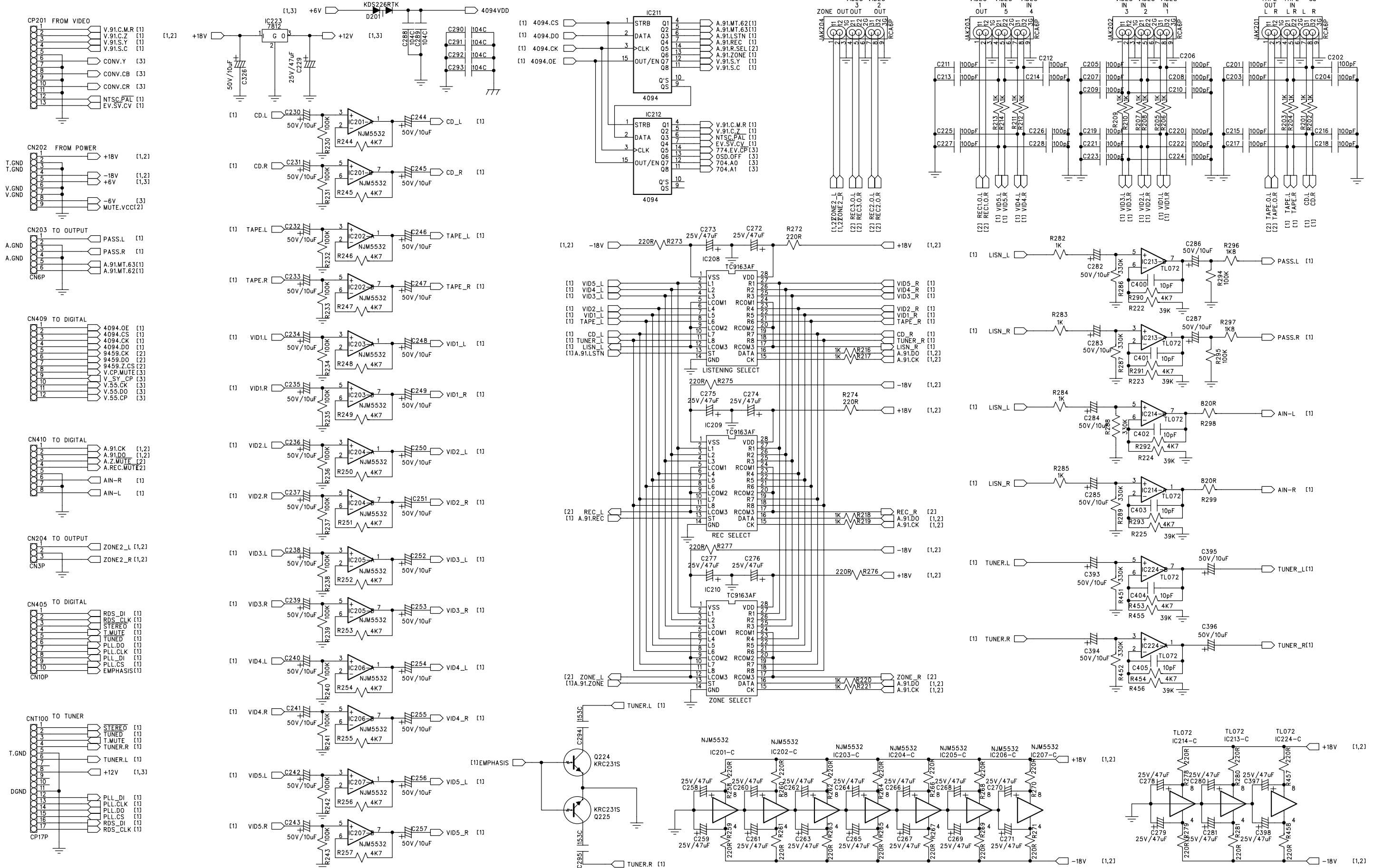

Schematic Diagram 2/13

INPUT (2/3) 016 E-1459A00

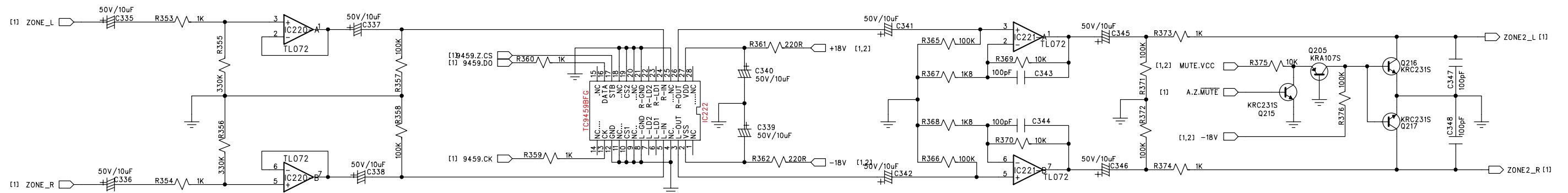
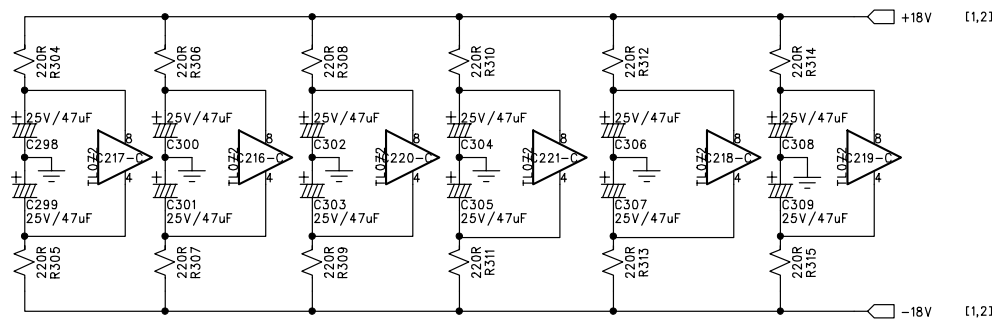
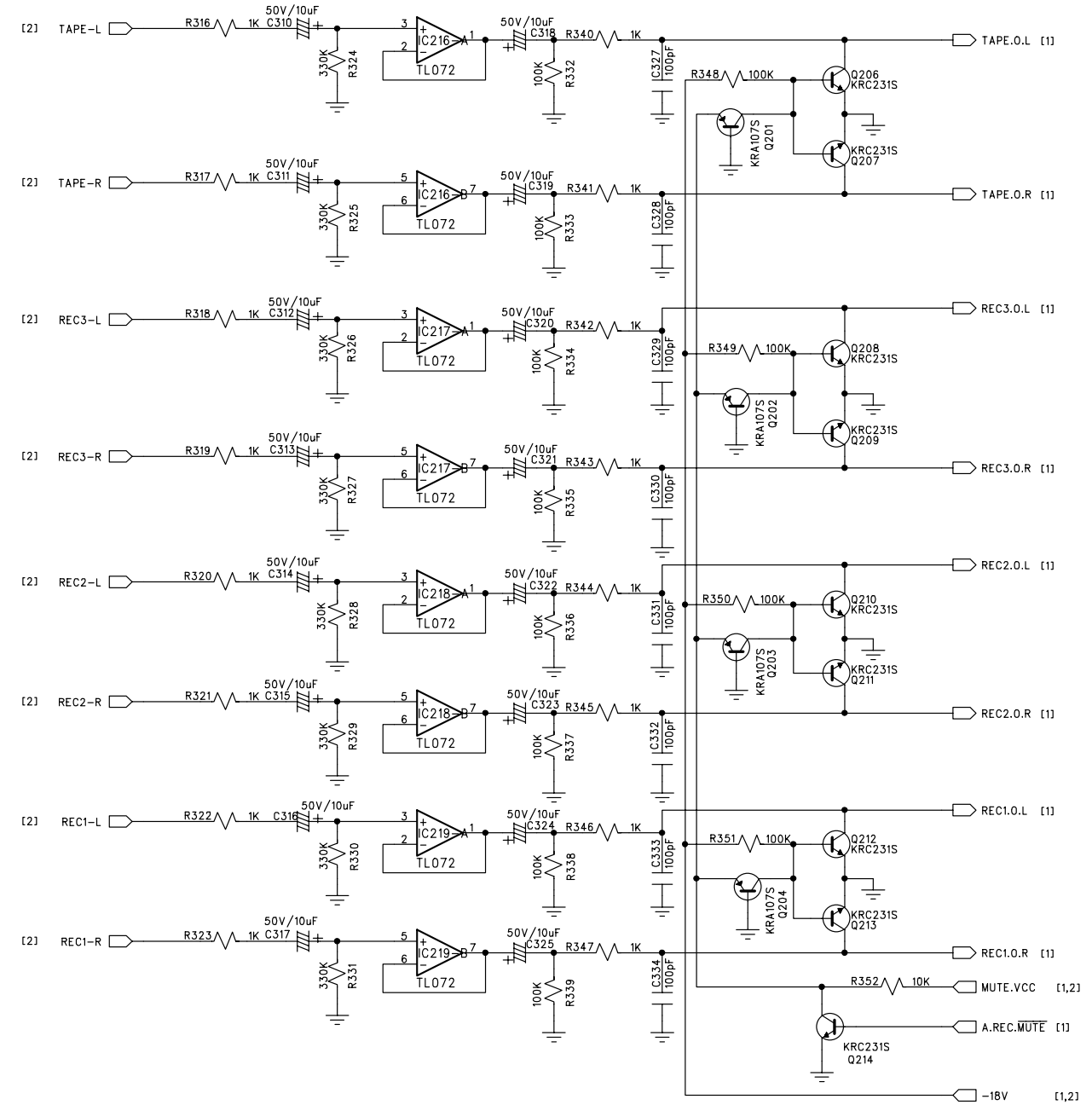
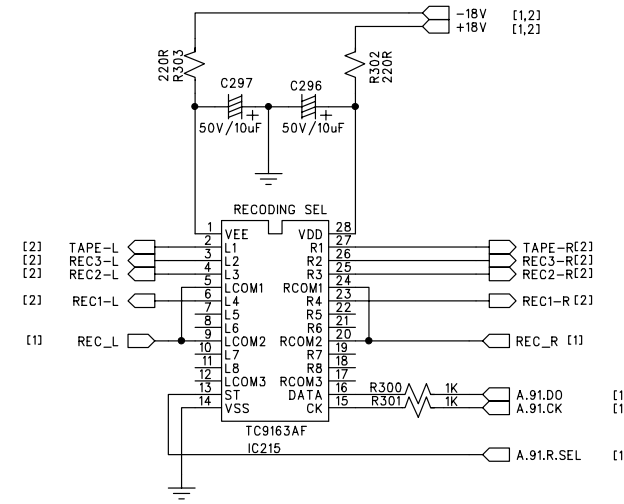

INPUT (3/3) 016 E-1459A00

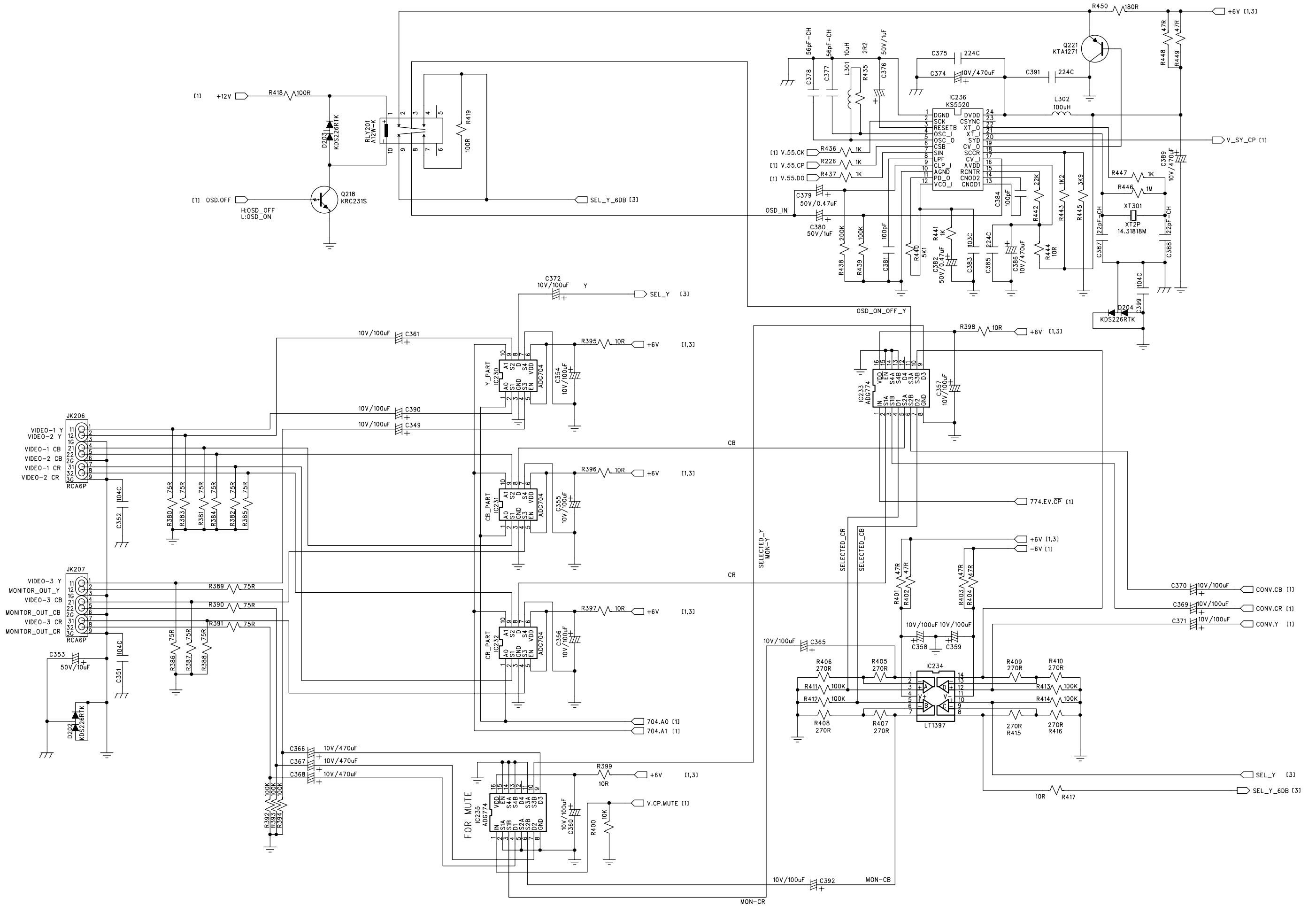

Schematic Diagram 4/13

Front PCB 016X-1408A01-03

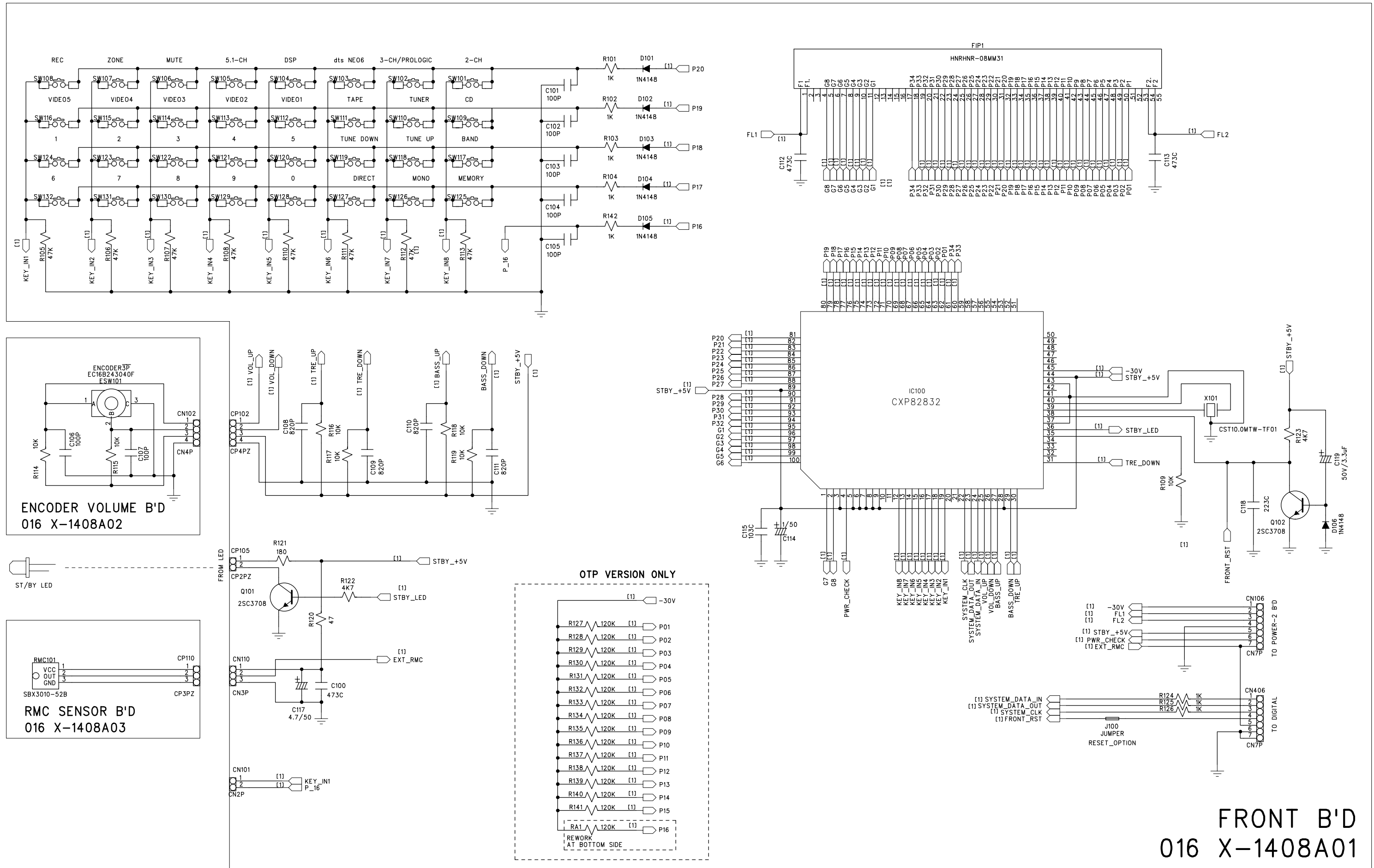

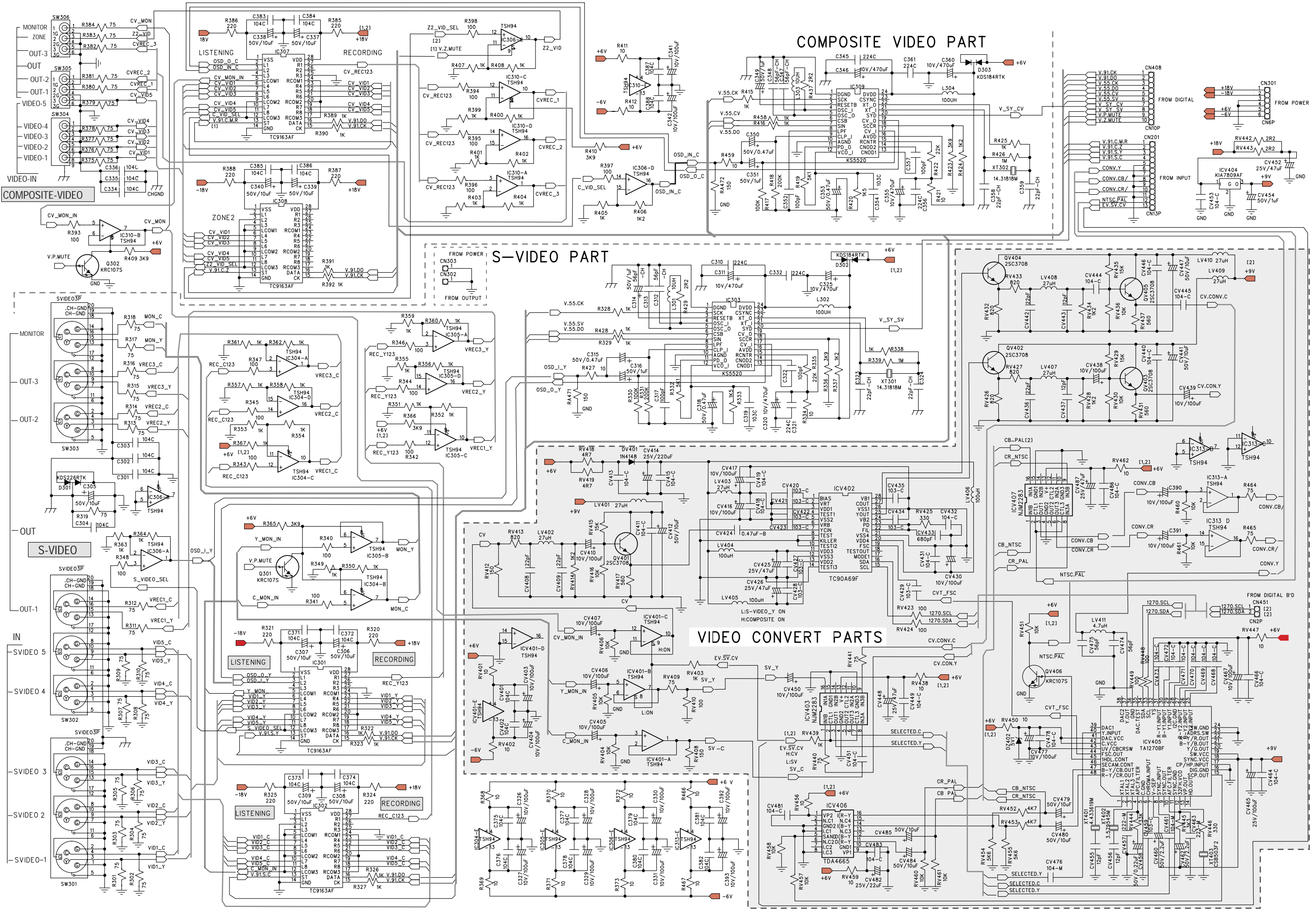

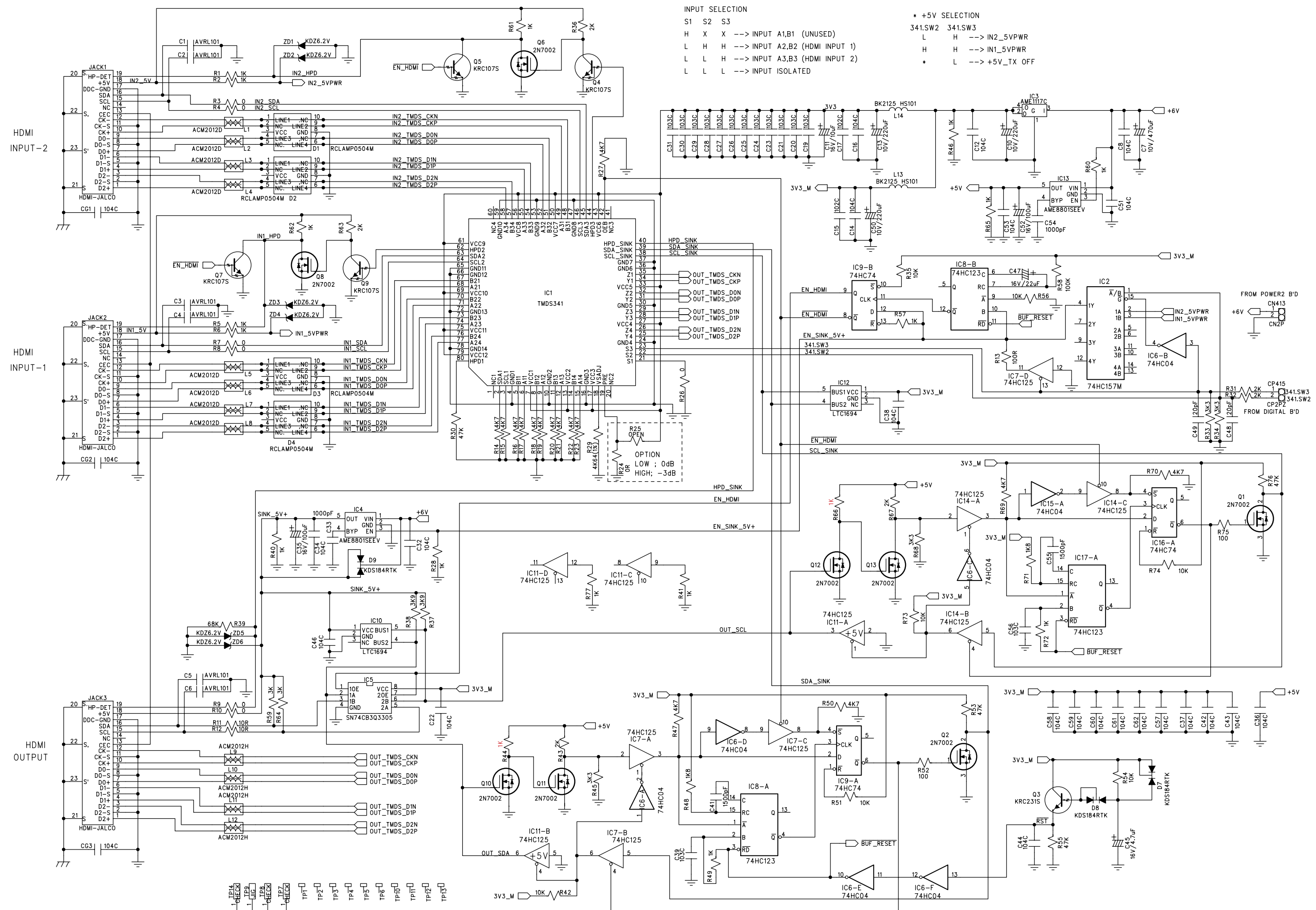

INPUT SELECTION

S1	S2	S3	
H	X	X	--> INPUT A1,B1 (UNUSED)
L	H	H	--> INPUT A2,B2 (HDMI INPUT 1)
L	L	H	--> INPUT A3,B3 (HDMI INPUT 2)
L	L	L	--> INPUT ISOLATED

+5V SELECTION

341.SW2	341.SW3	
L	H	--> IN2_5VPWR
H	H	--> IN1_5VPWR
*	L	--> +5V_TX OFF

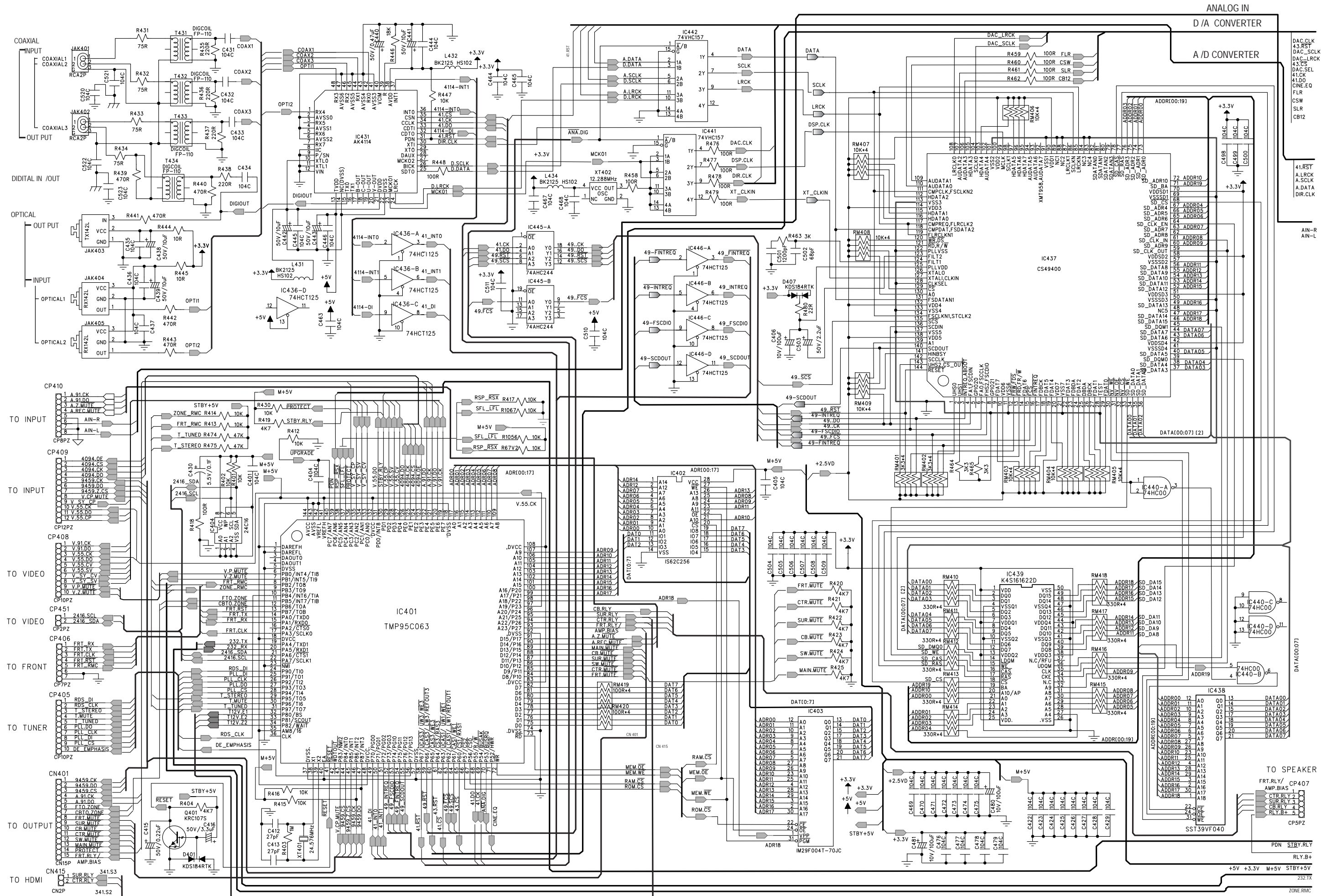

Schematic Diagram 8/13

DIGITAL (2/2) 016 E-1449A00

D/A CONVERTER

A/D CONVERTER

	AK5383	AK5385
R5385A	open	0 ohm
R5385B	open	0 ohm
R5383	47K	open
C5383	224C	open

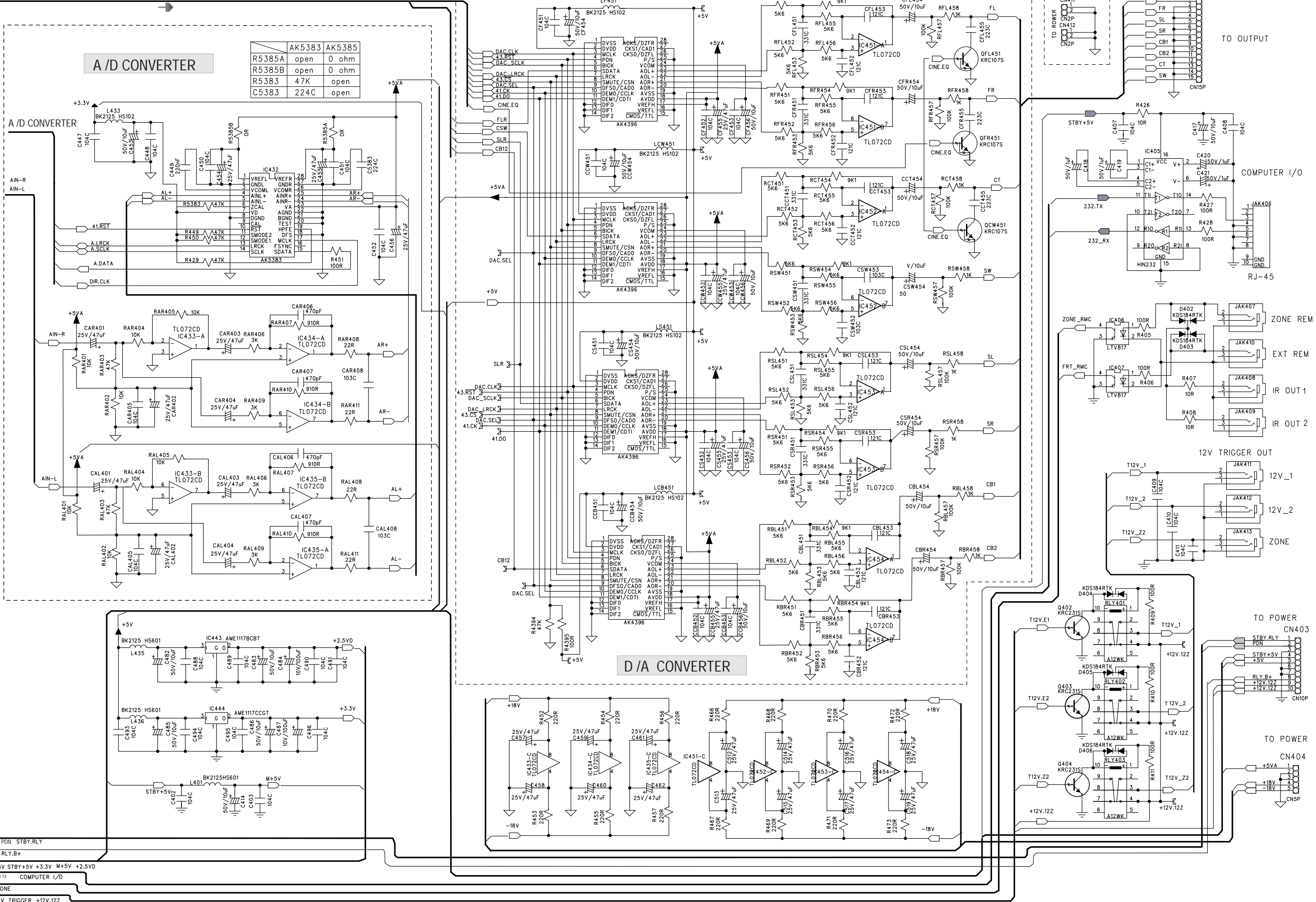

PDN STBY.RLY
 RLY.B+
 +5V STBY+5V +3.3V M+5V +2.5V
 232.TX COMPUTER I/O
 ZONE
 12V TRIGGER +12V.12Z

OUTPUT 016 E-1419B00

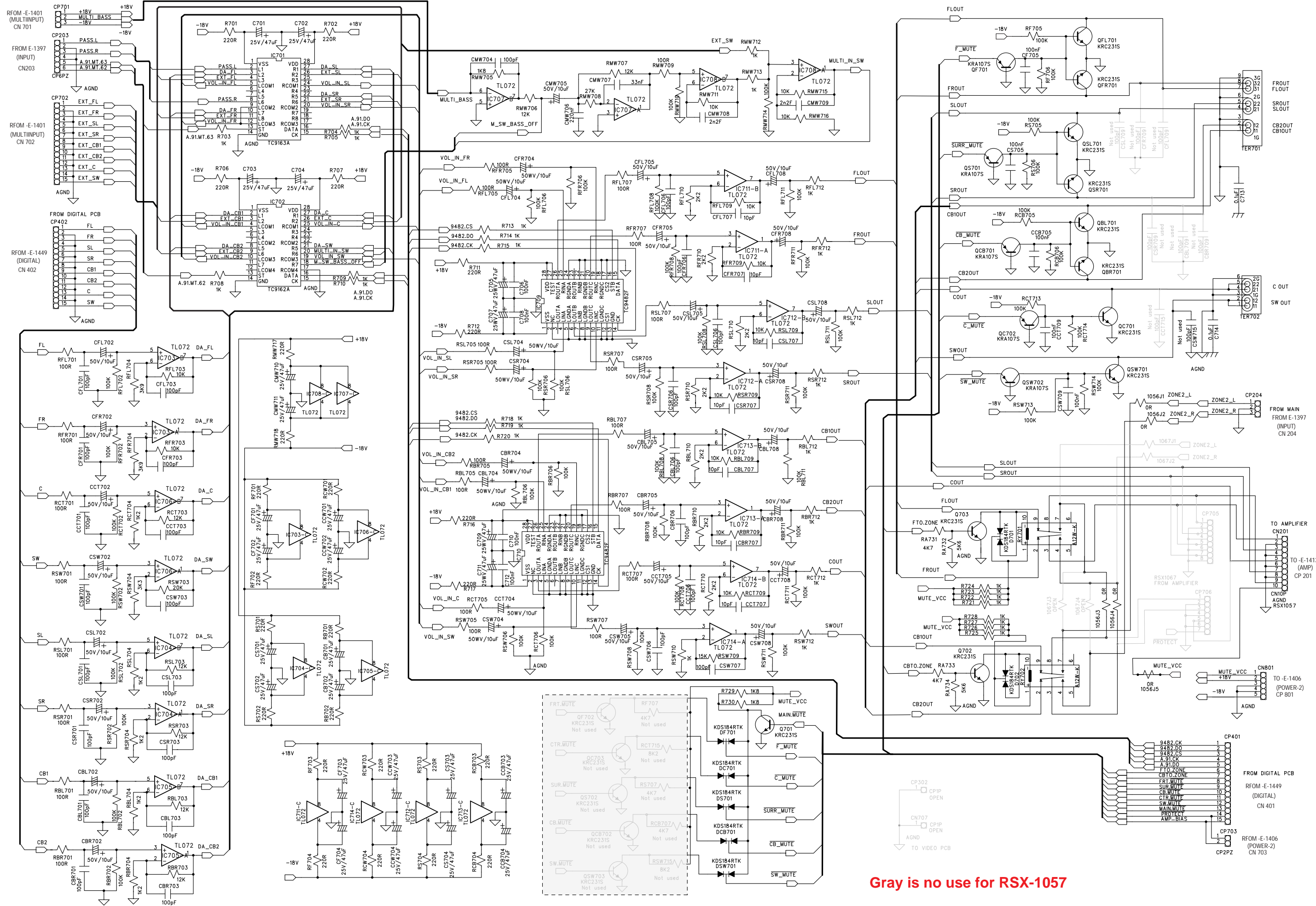

Gray is no use for RSX-1057

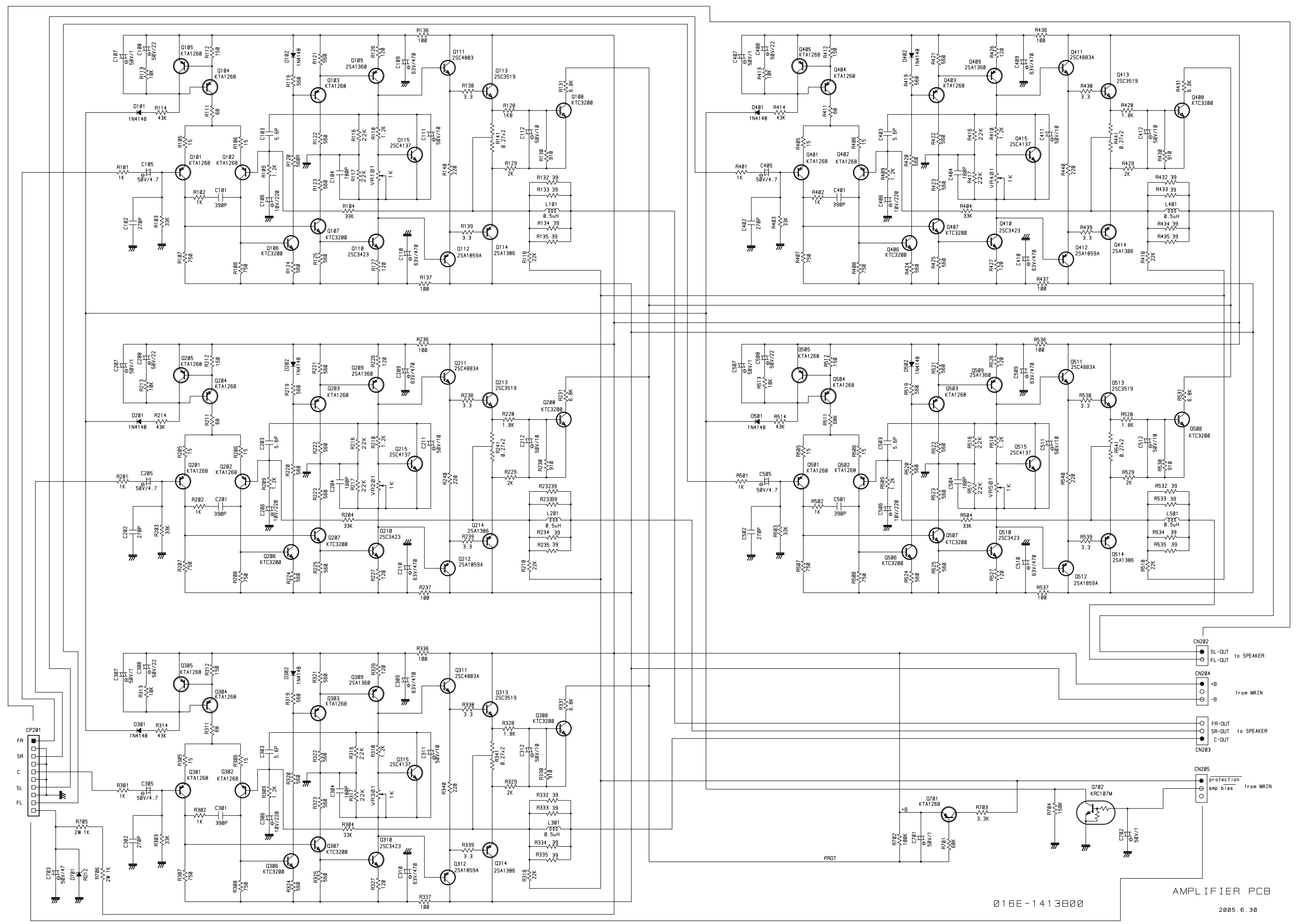

- SL-OUT to SPEAKER
- FL-OUT
- +B from MAIN
- -B
- FR-OUT to SPEAKER
- SR-OUT
- C-OUT
- protection amp bias from MAIN
-

016E-1413B00
AMPLIFIER PCB
2005.6.30

Power -1 PCB 016E-1405C00

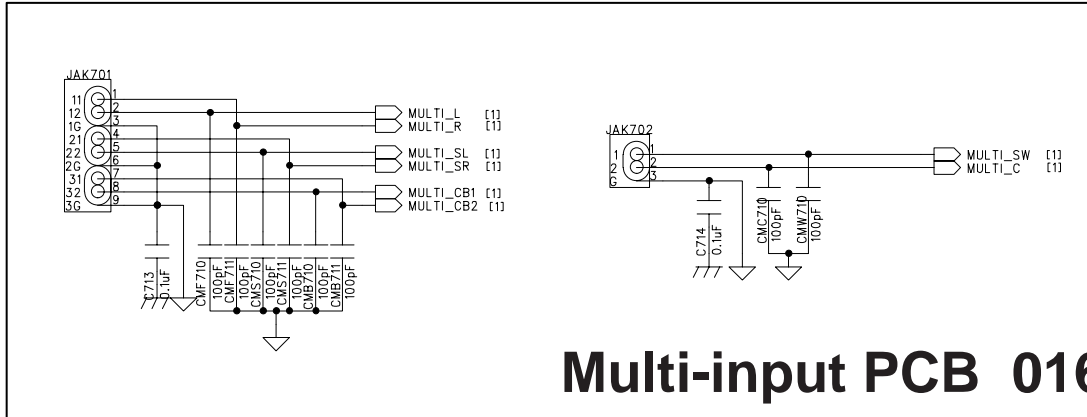
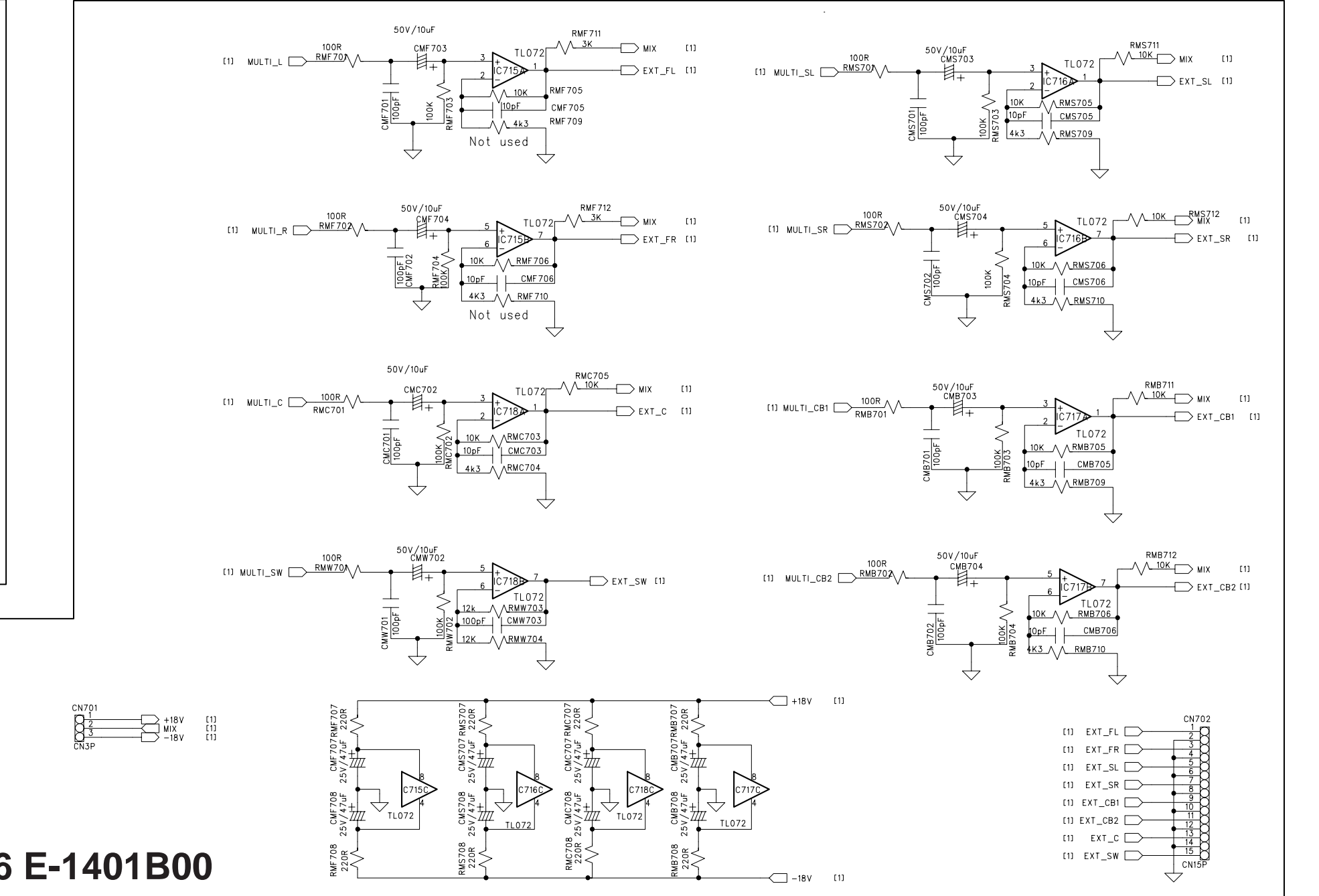
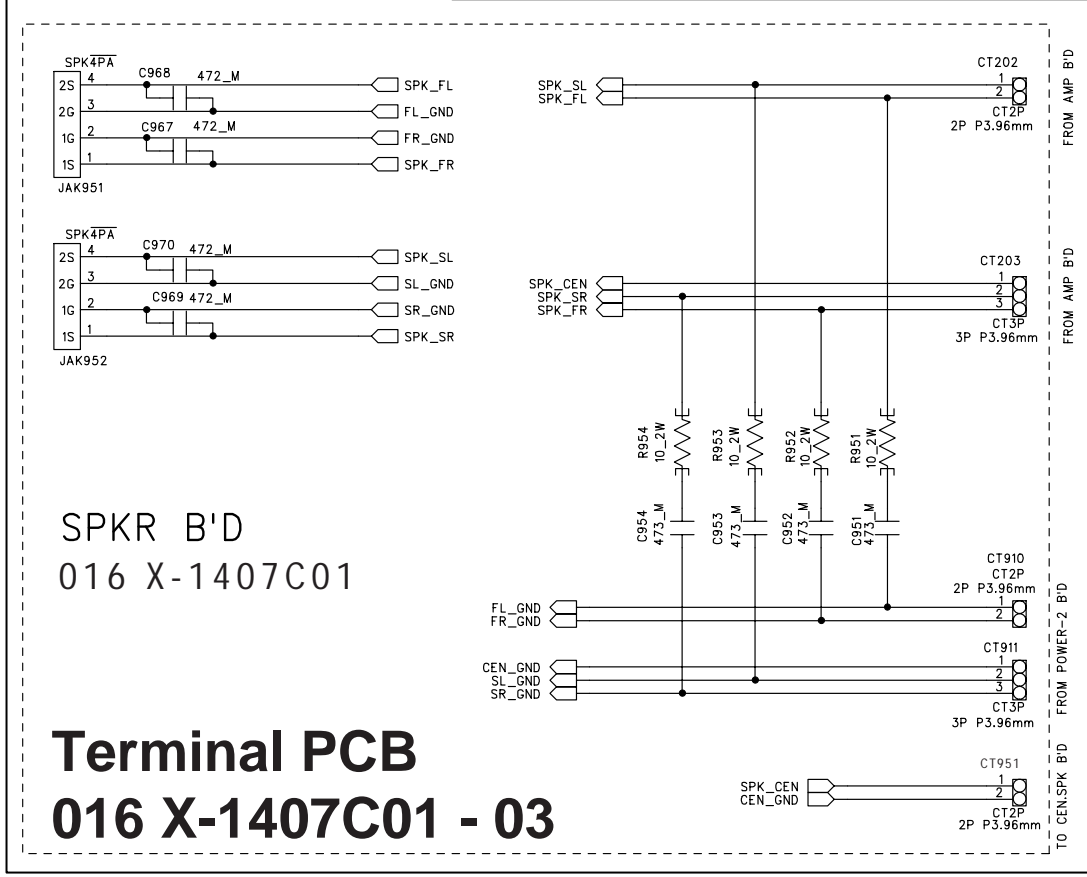
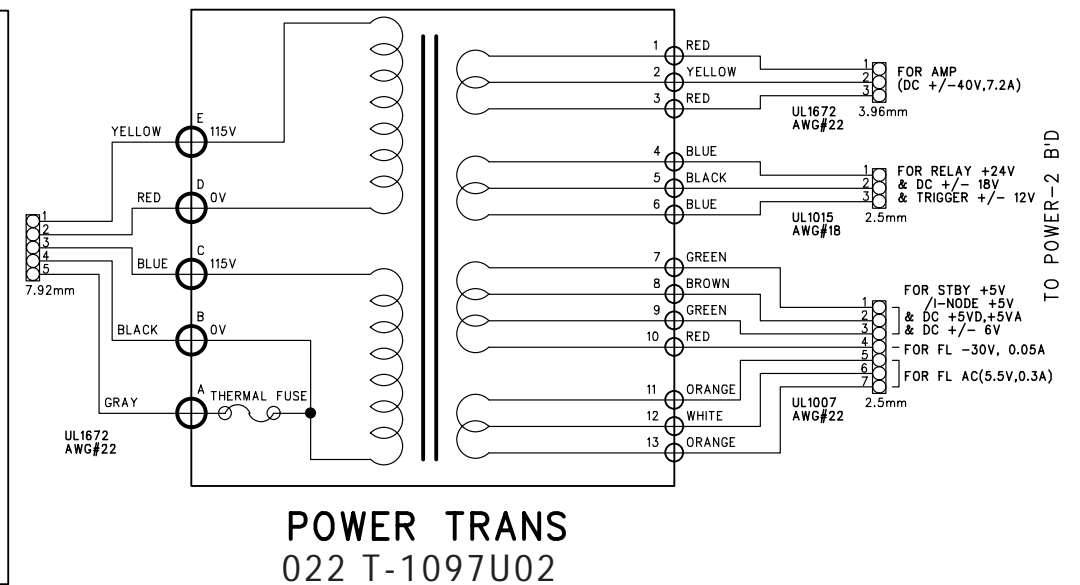
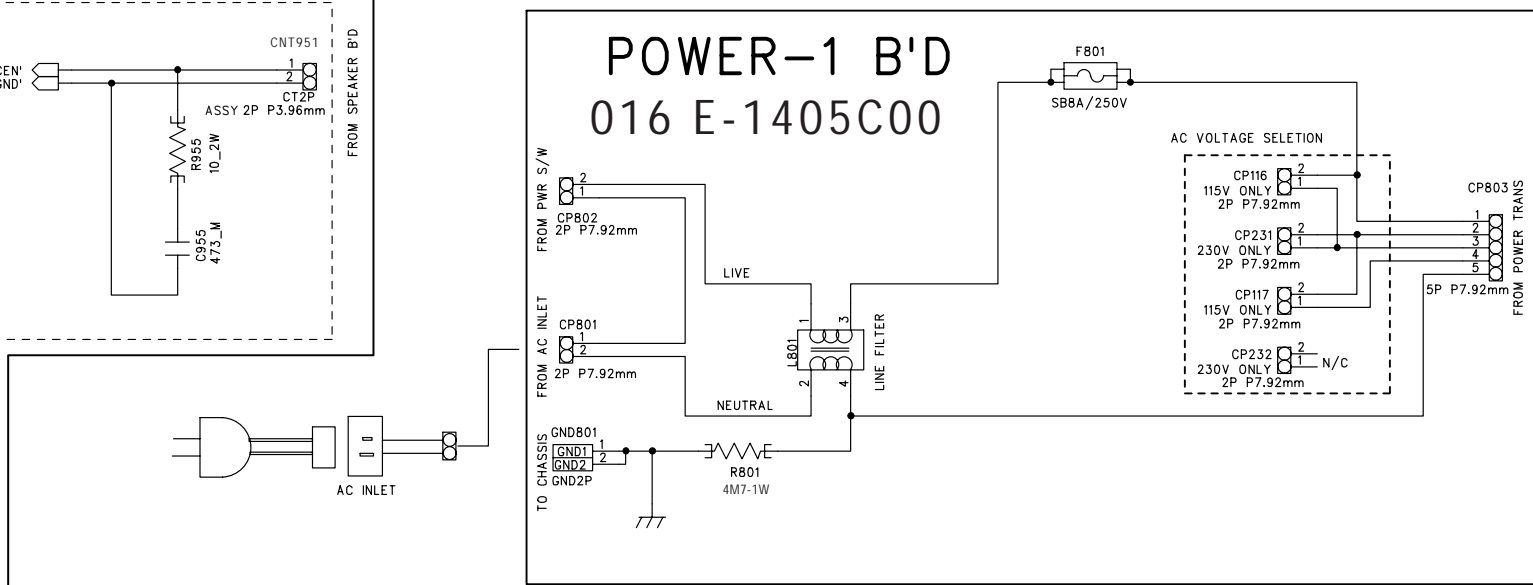
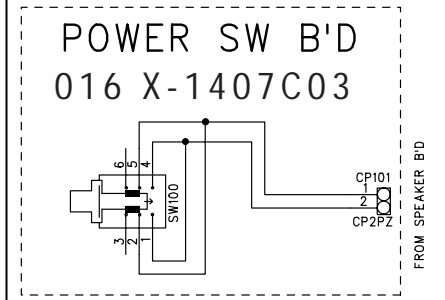
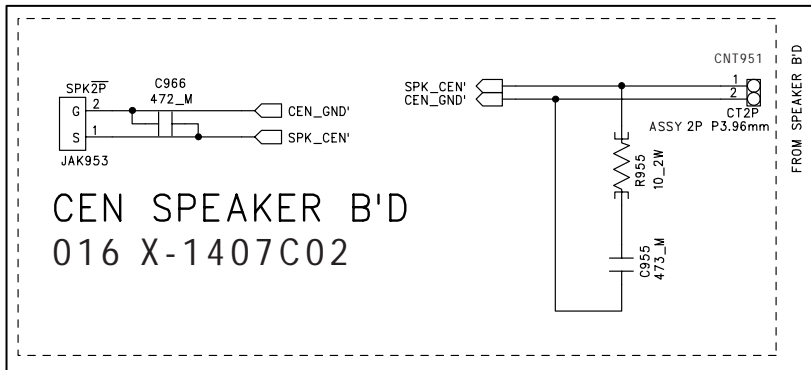

Schematic Diagram 12/13

POWER-2 016E1406E00

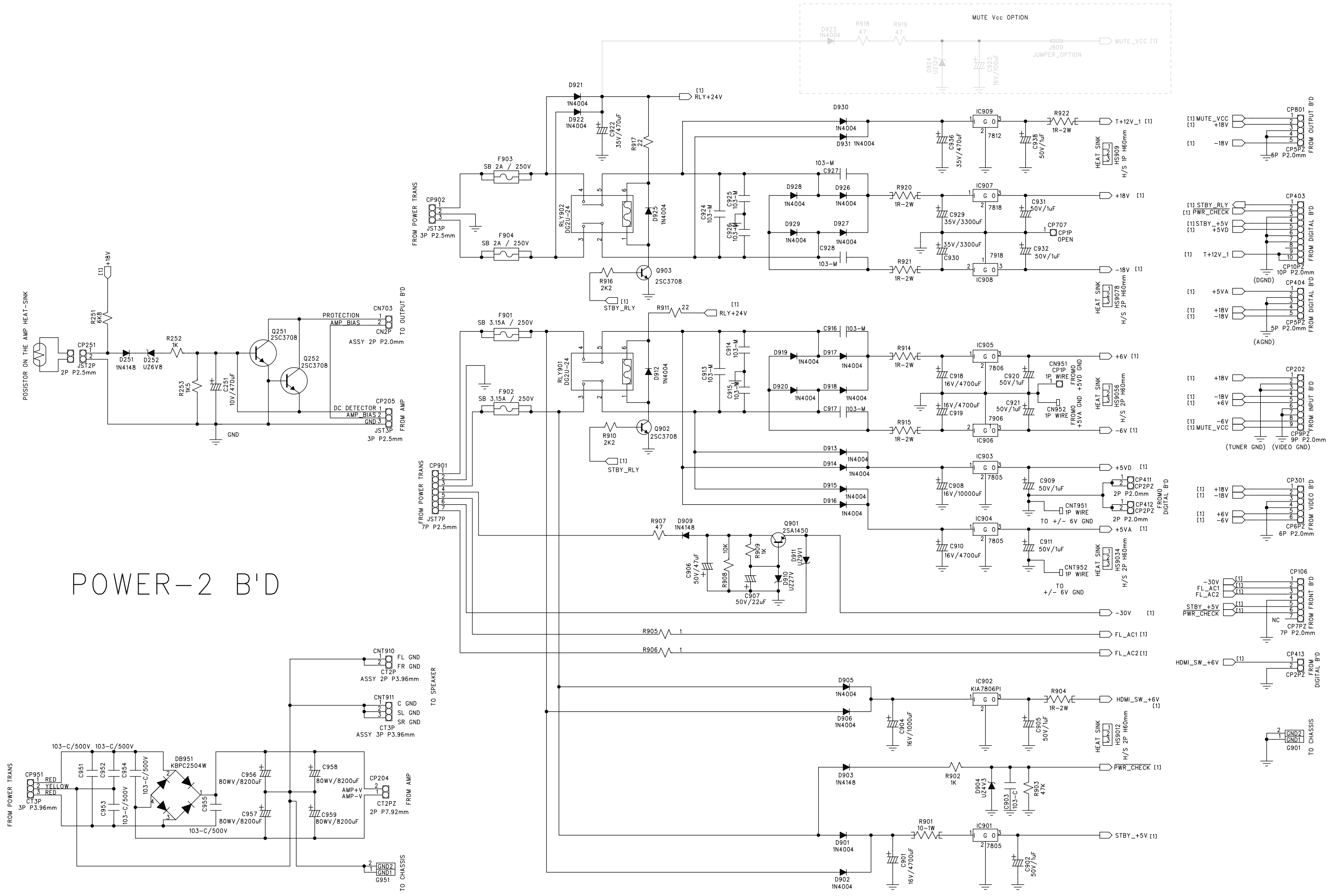

POWER-2 B'D

Tuner Module 092 MB114MA1-1B

