



# Technical Manual

## SURROUND SOUND RECEIVER **RSX-972**

### Table of Contents

- Appearance.....2
- Wiring Diagram.....3
- Disassembly Diagram.....4
- Disassembly Diagram List.....5
- Specifications.....6
- Parts List.....7 - 14
- Chassis Layout.....15
- Adjustment.....16 - 17
- Conversion.....18
- Case Outlines.....19 - 20
- PCB Assembly.....21 - 25
- Schematic Diagram.....26 - 34

See Page 22 for Backup Memory Cap Location

**THE ROTEL CO., LTD.**  
 SHINSEN-BLD. 4F 10-10 SHINSEN-CHO, SHIBUYA-KU,  
 TOKYO 150-0045, JAPAN

Serial. NO. Beginning
--------------------------

# Appearance

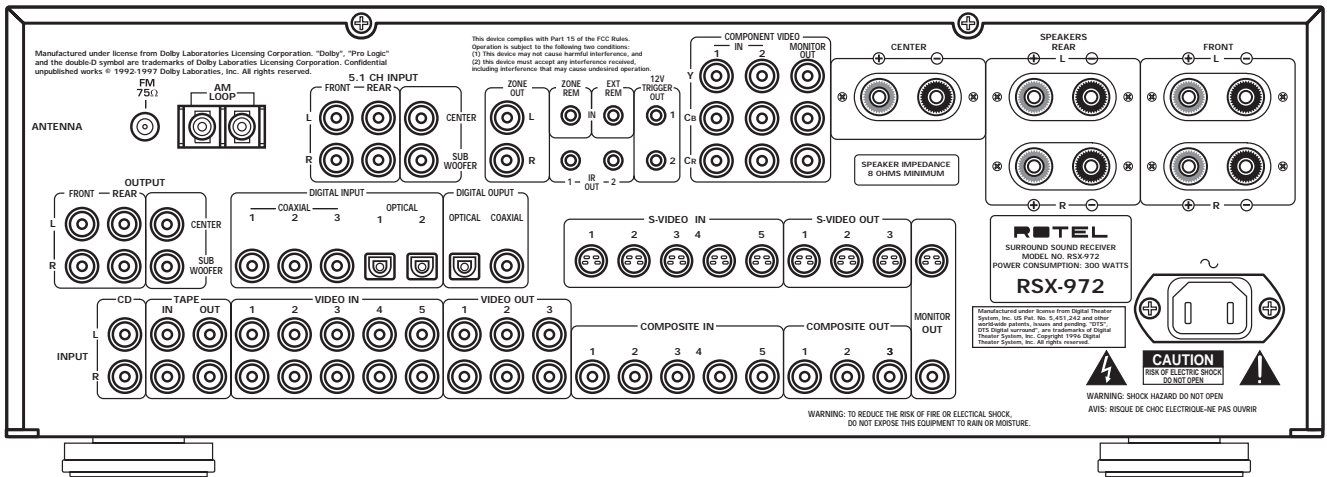
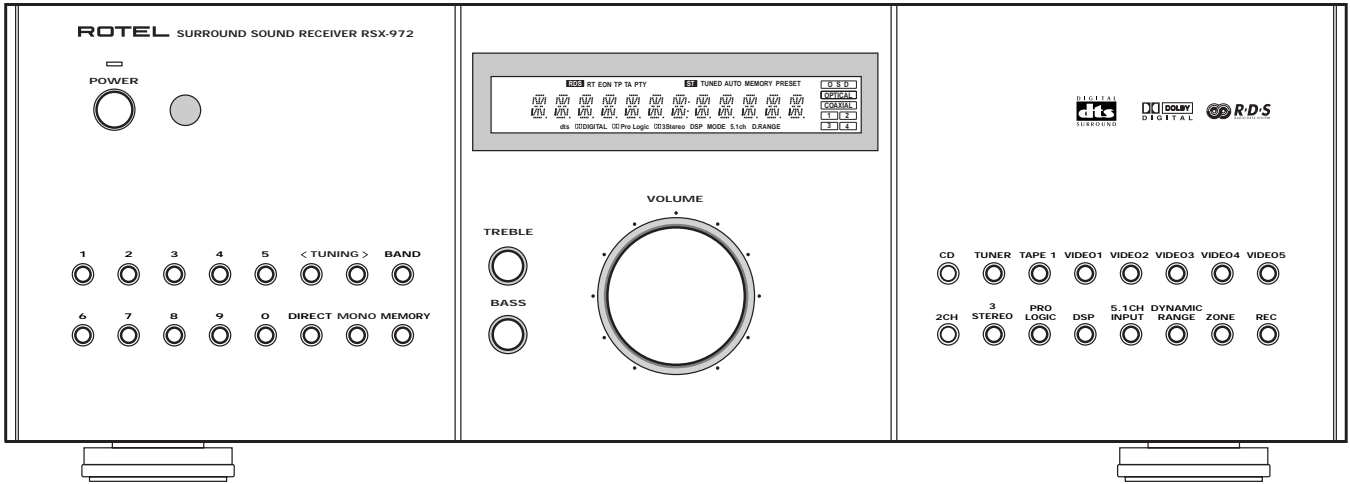

# WIRING DIAGRAM

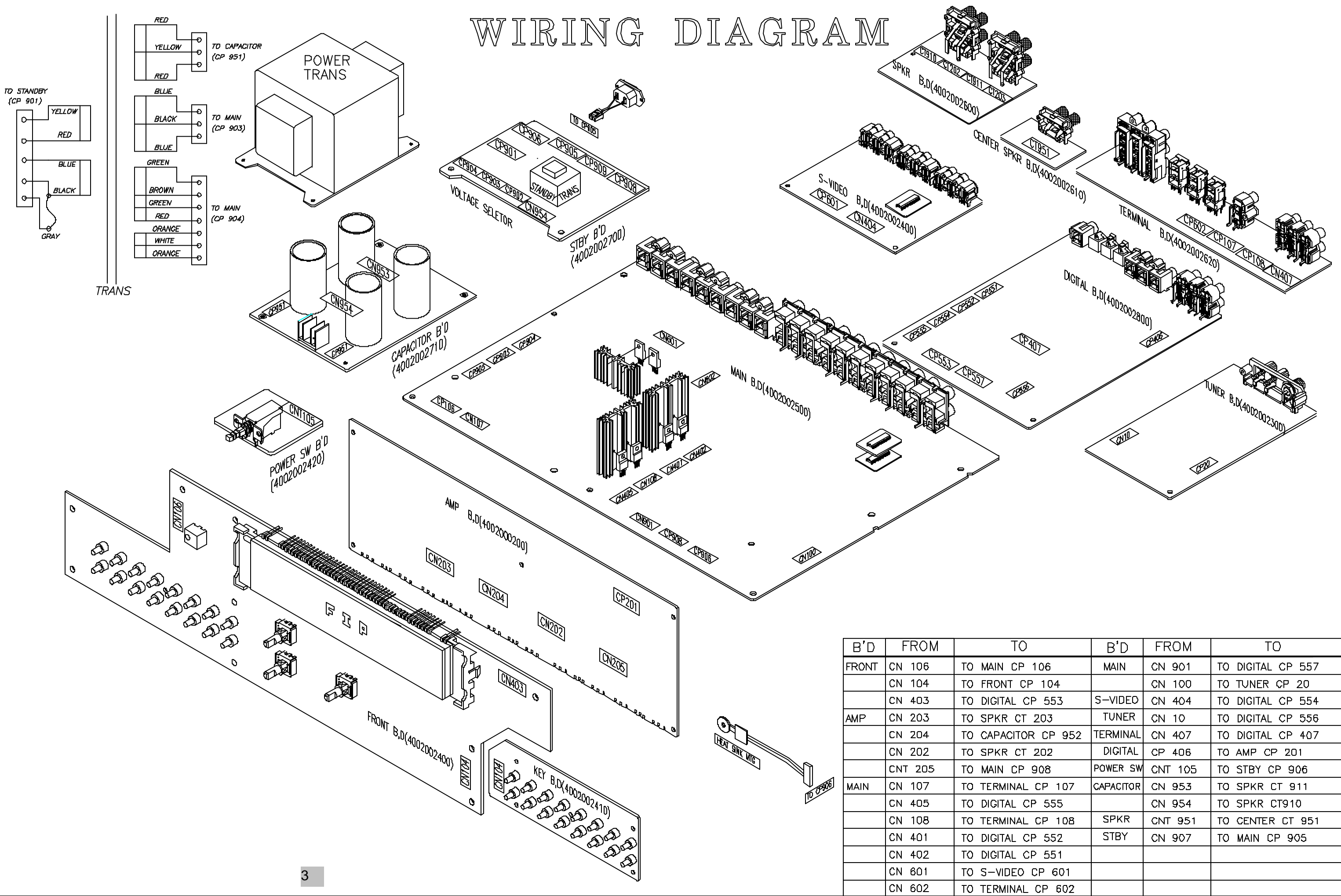

B'D	FROM	TO	B'D	FROM	TO
FRONT	CN 106	TO MAIN CP 106	MAIN	CN 901	TO DIGITAL CP 557
	CN 104	TO FRONT CP 104		CN 100	TO TUNER CP 20
	CN 403	TO DIGITAL CP 553		S-VIDEO	CN 404
AMP	CN 203	TO SPKR CT 203	TUNER	CN 10	TO DIGITAL CP 556
	CN 204	TO CAPACITOR CP 952	TERMINAL	CN 407	TO DIGITAL CP 407
MAIN	CN 202	TO SPKR CT 202	DIGITAL	CP 406	TO AMP CP 201
	CNT 205	TO MAIN CP 908	POWER SW	CNT 105	TO STBY CP 906
	CN 107	TO TERMINAL CP 107	CAPACITOR	CN 953	TO SPKR CT 911
	CN 405	TO DIGITAL CP 555		CN 954	TO SPKR CT910
	CN 108	TO TERMINAL CP 108	SPKR	CNT 951	TO CENTER CT 951
	CN 401	TO DIGITAL CP 552	STBY	CN 907	TO MAIN CP 905
	CN 402	TO DIGITAL CP 551			
	CN 601	TO S-VIDEO CP 601			
	CN 602	TO TERMINAL CP 602			

# Disassembly Diagram

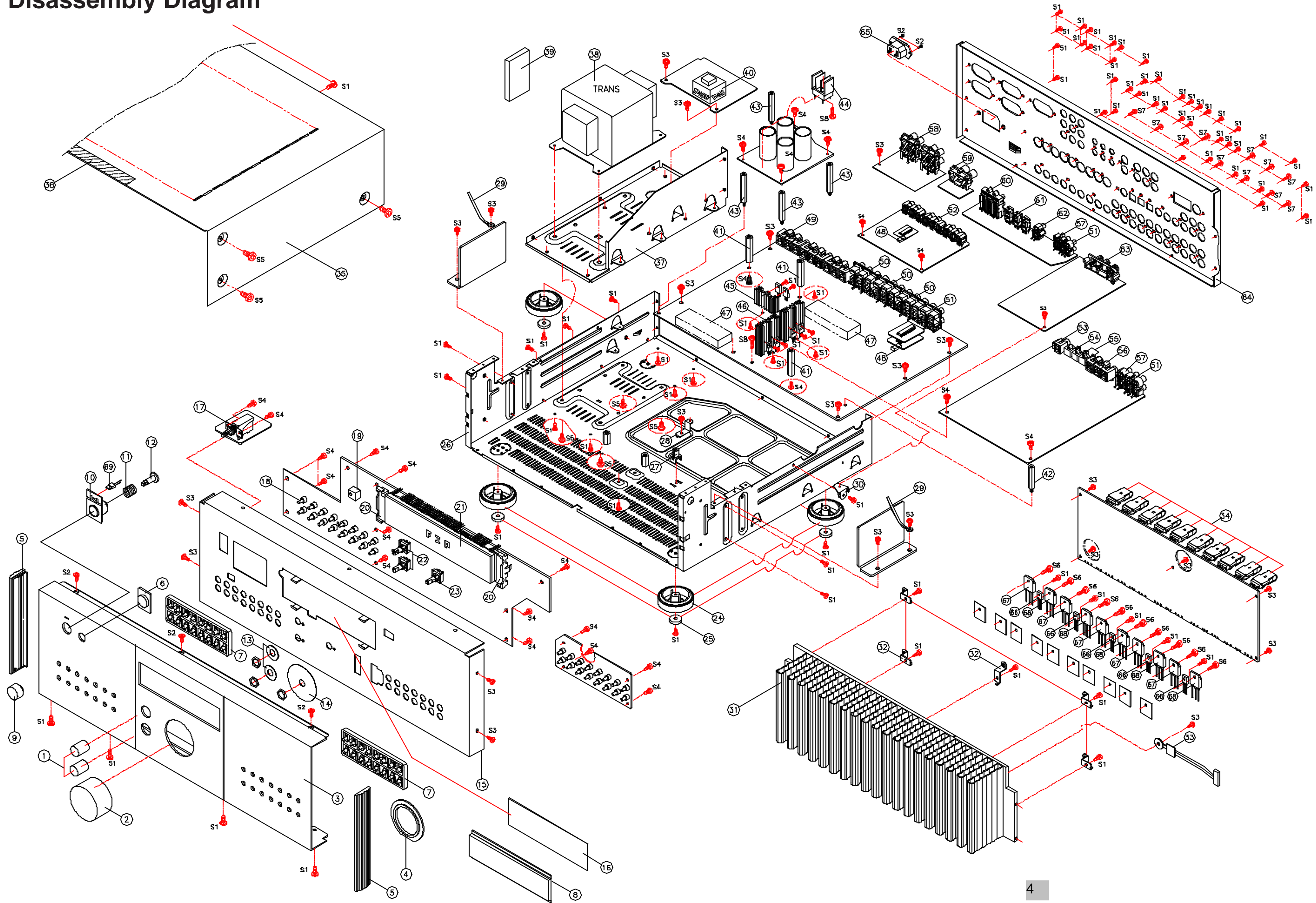

## DISASSEMBLY PARTS LIST

NO.	PARTS NO.	DESCRIPTION	NO.	PARTS NO.	DESCRIPTION
1	8645000211	KNOB ROTARY, AL A6063S-T5	55	2408218001	OPTO JACK RX-8A
2	8543000211	KNOB MAIN, AL A6063S-T5	56	4438100530	JACK RCA 3P(B)
3	8602000611	FRONT PANEL, AL A6063S-T5	57	4438100920	JACK RCA 2P(B,B WOOFER)
4	8545000511	BEZEL RING(47F), ABS RED SPRAY	58	4408101010	SPEAKER TERMINAL 4P
5	8523000210	CAP SIDE, ABS BLACK	59	4408101110	SPEAKER TERMINAL 2P
6	8555000510	WINDOW SENSOR ,ACRYL WINE	60	4438101220	JACK RCA 9P(GR,BL,R)
	(019 C-4525A00T)		61	4438300210	JACK MINIATURE 2P(3.5mm) BLACK
7	8543000510	BUTTON 16KEY, ABS BLACK	62	4438100120	JACK RCA 2P(W,R)
	(012 TB3-18A00)		63	4408000320	TERMINAL ANT(GND),SC0210586N
8	8555000411	WINDOW DISPLAY. ACRYL 5.0t	64	6102000611	CH.BACK,SECC1.0t
9	8545000110	BUTTON F14, ABS BLACK	65	436302200047	ASS'Y INLET
	(012 RV4-09A00)		66	2028416122	TR NPN 2SC3519A W/ACC
10	8545000710	BUTTON POWER RING, ABS BLACK	67	2008622110	TR NPN 2SC4137 FOR BIAS
	(019 C-4525A00T)		68	2028116108	TR PNP2SA1386A W/ACC
11	6555600110	SPRING BTN,SUS	69	2381851712	LED RED1X5 (034SEL 1124R)
	(019 4TR-1988A#2)				
12	6305000110	BTN CONNECTOR PUSH, ABS BLACK			
	(019 4TTL-15)				
13	6725000110	FELT VR(TONE)F20			
14	6725000120	FELT VR(TONE)F52			
15	6122200110	CH FRONT, SECC1t			
16	8535000310	FILTER FL ,ACRYL1.0t WINE			
17	4628000110	POWER SWITCH, TV-5			
18	4658000210	SW TACT SKHVBHD010			
19	2408000190	REMOCON SENSOR SBX3010-52B			
20	6515000110	HOLDER FIP, ABS BLACK			
21	2328000302	FIP SVR08LM02			
22	3218000410	VR ENCODER WITH DETENT EC16B2420431			
23	3218000310	VR ENCODER WITHOUT DETENT.EC16B243040H			
24	6133100110	FOOT, ABS BLACK			
25	6715000110	BUMPON			
26	6121600120	MAIN CHASSIS, SECC1.2t			
27	6515000210	SPACER PCB, ABS BLACK			
28	6505000120	BKT H/SINK(M3 TAP), SECC1.0t			
29	6528000210	CLAMP WIRE			
30	6505000310	BKT PCB,SECC 1.0t			
31	7502000110	POWER HEAT SINK, AL A6063S-T5			
32	6505000110	BKT H/SINK, SECC1.0t			
33	436102102031	ASS'Y POSISTOR			
34	7505000610	H/SINK SPRING			
35	6122000110	TOP COVER, VCM 0.95t			
36	6715000210	SPONGE, 260X20X1t			
37	6122600120	FRAME T/F, SECC 1.0t			
38	2828000107	T/F MAIN			
39	6715000310	SPONGE, 50X40X5t			
40	2828000097	T/F STANDBY			
41	6535000310	STUD SPACER(H:35mm),MBsBE1			
42	6535000110	STUD SUPPORT(H:35mm),MBsBE1			
43	6535000120	STUD SUPPORT(H:45mm),MBsBE1			
44	7505000410	BRIDGE DIODE H/SINK			
45	7505000310	H/SINK REG TR(46X12X30), AL			
46	7505000330	H/SINK REG TR(46X12X60), AL			
47	6715000520	SPONGE PCB BTM, 70X30X12t			
48	6715000810	SPONGE, 10X5X3t			
49	4438100520	JACK RCA 3P(Y), VIDEO			
50	4438100320	JACK RCA 6P(WWW,RRR)			
51	4438100220	JACK RCA 4P(W,R)			
52	4438500210	JACK RCA 3P, S-VHS			
53	4438100730	JACK RCA 1P (B)			
54	2408008001	OPTO JACK TOTX178A			
<b>SCREW</b>					
S1	8109430083	SCREW #B BTT 3X8B			
S2	8129430083	SCREW #2FTC 3X8B			
S3	8159430061	SCREW #B WPTT 3X6Y			
S4	8069130064	SCREW #WPMS 3X6NI			
S5	8159440083	SCREW #WSAM 4X8B			
S6	8179430121	SCREW HEAT SINK			
S7	8199430103	SCREW G.N.D			
S8	8159430181	SCREW #B WPTT 3X18Y			
<b>PACKING &amp; LABELS</b>					
	9007000710	INSTRUCTION MANUAL FOR RSX972			
	2608207360	AM ANT LOOP			
	4348000110	FM ANT			
	9087000010	WARRANTY CARD			
	4428400110	MATCHING TRANS			
	9705000110	POLY BAG			
	9057000010	FUSE LABEL			
	9057000020	GRAPHIC LABEL			
	9722000110	CUSHION POLY			
	9605000115	BOX CARTON(INNER)			
	9625000115	BOX CARTON(OUT)			
	9715000110	FILM SOFT PE ( BAG TYPE)			
	9057000110	LABEL UL(30X27 )			
	9057000210	LABEL 120V-60Hz			
	9057000220	LABEL 230V-50H z (CE)			

# Specifications

## Audio

### Continuous Amplifier Power (all channels driven)

75 watts/ch (20-20k Hz, <0.09% THD, 8 ohms)  
100 watts/ch (1kHz, <1.0% THD, 8 ohms, DIN)

### Total Harmonic Distortion

<0.09%

### Intermodulation Distortion (60 Hz:7kHz)

<0.09%

### Frequency Response

10 Hz - 20 kHz,  $\pm 1$  dB (line level)  
10 Hz - 20 kHz,  $\pm 0.3$  dB (digital level)

### Signal to Noise Ratio (IHF A-weighted)

92 dB (Stereo) Analog  
90 dB (Dolby Digital, dts) 0dBFS

### Input Sensitivity/Impedance

Line Level: 200 mV/47 kohms

### Tone Controls (Bass/Treble)

$\pm 8$  dB at 100 Hz/10 kHz

### Line Output Level

600 mV (200 mV Input)

## Video

### Frequency Response

3 Hz-10 MHz,  $\pm 3$  dB

### Signal to Noise Ratio

45 dB

### Input Impedance

75 ohms

### Output Impedance

75 ohms

### Output Level

1 volt

## FM Tuner

### Usable Sensitivity

14.2 dBf

### Signal to Noise Ratio (at 65 dBf)

70 dBf

### Harmonic Distortion (at 65 dBf)

0.03%

### Stereo Separation (1 kHz)

45 dB

### Output level

1 V

### Antenna Input

75 ohms unbalanced

## AM Tuner

### Sensitivity

500  $\mu$ V/m

### Signal to Noise Ratio

40 dBf

### Output level

500 mV

### Antenna Input

Loop Antenna

## General

### Power Consumption:

850 watts

### Power Requirements (AC)

115 volts, 60Hz (USA)  
230 volts, 50Hz (CE)

### Weight

15 Kg/33 lb.

### Dimensions (W x H x D)

445 x 160 x 400 mm  
17 1/2 " x 6 1/4 " x 15 3/4 "

All specifications are accurate at the time of printing.



## Parts List 1/8

SYMBOL	PART NO.	DESCRIPTION	SYMBOL	PART NO.	DESCRIPTION
<b>AMPLIFIER PCB 4002000200</b>					
	4002000200	PCB Assembly	CR212	3479347181	CAP E SG 470uF/63V
CC209	3519181935	CAP C AXIAL 180PF/50V J	CSL212	3479347181	CAP E SG 470uF/63V
CL209	3519181935	CAP C AXIAL 180PF/50V J	CSR212	3479347181	CAP E SG 470uF/63V
CR209	3519181935	CAP C AXIAL 180PF/50V J	C216	3479347071	CAP E SG 47uF/50V
CSL209	3519181935	CAP C AXIAL 180PF/50V J	CP201	4428510416	CNT PLUG ST GIL-S-10P-S2T2-EF
CSR209	3519181935	CAP C AXIAL 180PF/50V J	LC201	2648601470	COIL INDUCTOR 0.5UH
CC202	3519271935	CAP C AXIAL 270PF/50V J	LL201	2648601470	COIL INDUCTOR 0.5UH
CL202	3519271935	CAP C AXIAL 270PF/50V J	LR201	2648601470	COIL INDUCTOR 0.5UH
CR202	3519271935	CAP C AXIAL 270PF/50V J	LSL201	2648601470	COIL INDUCTOR 0.5UH
CSL202	3519271935	CAP C AXIAL 270PF/50V J	LSR201	2648601470	COIL INDUCTOR 0.5UH
CSR202	3519271935	CAP C AXIAL 270PF/50V J	CN204	436502122167	CTJ 0212 201,210 DL #18 P7.92
CC203	3519391935	CAP C AXIAL 390PF/50V J	CN202	436502452166	CTJ 0245 201,210 DL #18 P3.96
CL203	3519391935	CAP C AXIAL 390PF/50V J	CN203	436503302166	CTJ 0330 201,210 DL #18 P3.96
CR203	3519391935	CAP C AXIAL 390PF/50V J	CN205	436103083525	CTM 0308 5263,5394 DL #26 P2.5
CSL203	3519391935	CAP C AXIAL 390PF/50V J	DC201	2058322101	DIODE 1N4148
CSR203	3519391935	CAP C AXIAL 390PF/50V J	DL201	2058322101	DIODE 1N4148
CC207	3519569935	CAP C AXIAL 5.6PF/50V J	DR201	2058322101	DIODE 1N4148
CL207	3519569935	CAP C AXIAL 5.6PF/50V J	DSL201	2058322101	DIODE 1N4148
CR207	3519569935	CAP C AXIAL 5.6PF/50V J	DSR201	2058322101	DIODE 1N4148
CSL207	3519569935	CAP C AXIAL 5.6PF/50V J	DC202	2058322101	DIODE 1N4148
CSR207	3519569935	CAP C AXIAL 5.6PF/50V J	DL202	2058322101	DIODE 1N4148
CC211	3479310071	CAP E SG 10uF/50V	DR202	2058322101	DIODE 1N4148
CL211	3479310071	CAP E SG 10uF/50V	DSL202	2058322101	DIODE 1N4148
CR211	3479310071	CAP E SG 10uF/50V	DSR202	2058322101	DIODE 1N4148
CSL211	3479310071	CAP E SG 10uF/50V	ZD201	2258599120	DIODE ZENER T-72 UZ12V
CSR211	3479310071	CAP E SG 10uF/50V		4235007410	GND PLATE MET37-0002
CC214	3479310071	CAP E SG 10uF/50V	RC228-229	3029101270	RES MF 100 1/4W J
CL214	3479310071	CAP E SG 10uF/50V	RL228-229	3029101270	RES MF 100 1/4W J
CR214	3479310071	CAP E SG 10uF/50V	RR228-229	3029101270	RES MF 100 1/4W J
CSL214	3479310071	CAP E SG 10uF/50V	RSL228-229	3029101270	RES MF 100 1/4W J
CSR214	3479310071	CAP E SG 10uF/50V	RSR228-229	3029101270	RES MF 100 1/4W J
CC204	3479310971	CAP E SG 1uF/50V	R237	30291003910	RES MF 100K 1/5W F
CL204	3479310971	CAP E SG 1uF/50V	RC210	30291002910	RES MF 10K 1/5W F
CR204	3479310971	CAP E SG 1uF/50V	RL210	30291002910	RES MF 10K 1/5W F
CSL204	3479310971	CAP E SG 1uF/50V	RR210	30291002910	RES MF 10K 1/5W F
CSR204	3479310971	CAP E SG 1uF/50V	RSL210	30291002910	RES MF 10K 1/5W F
C215	3479310971	CAP E SG 1uF/50V	RSR210	30291002910	RES MF 10K 1/5W F
C217	3479310971	CAP E SG 1uF/50V	RC221-222	30291200910	RES MF 120 1/5W F
CC206	3479322121	CAP E SG 220uF/10V	RL221-222	30291200910	RES MF 120 1/5W F
CL206	3479322121	CAP E SG 220uF/10V	RR221-222	30291200910	RES MF 120 1/5W F
CR206	3479322121	CAP E SG 220uF/10V	RSL221-222	30291200910	RES MF 120 1/5W F
CSL206	3479322121	CAP E SG 220uF/10V	RSR221-222	30291200910	RES MF 120 1/5W F
CSR206	3479322121	CAP E SG 220uF/10V	RC203-204	30291509910	RES MF 15 1/5W F
CC205	3479322031	CAP E SG 22uF/16V	RL203-204	30291509910	RES MF 15 1/5W F
CL205	3479322031	CAP E SG 22uF/16V	RR203-204	30291509910	RES MF 15 1/5W F
CR205	3479322031	CAP E SG 22uF/16V	RSL203-204	30291509910	RES MF 15 1/5W F
CSL205	3479322031	CAP E SG 22uF/16V	RSR203-204	30291509910	RES MF 15 1/5W F
CSR205	3479322031	CAP E SG 22uF/16V	RC209	30291500910	RES MF 150 1/5W F
CC201	3479347971	CAP E SG 4.7uF/50V	RL209	30291500910	RES MF 150 1/5W F
CL201	3479347971	CAP E SG 4.7uF/50V	RR209	30291500910	RES MF 150 1/5W F
CR201	3479347971	CAP E SG 4.7uF/50V	RSL209	30291500910	RES MF 150 1/5W F
CSL201	3479347971	CAP E SG 4.7uF/50V	RSR209	30291500910	RES MF 150 1/5W F
CSR201	3479347971	CAP E SG 4.7uF/50V	R243	30291503910	RES MF 150K 1/5W F
CC210	3479347181	CAP E SG 470uF/63V	RC201	30291001910	RES MF 1K 1/5W F
CL210	3479347181	CAP E SG 470uF/63V	RL201	30291001910	RES MF 1K 1/5W F
CR210	3479347181	CAP E SG 470uF/63V	RR201	30291001910	RES MF 1K 1/5W F
CSL210	3479347181	CAP E SG 470uF/63V	RSL201	30291001910	RES MF 1K 1/5W F
CSR210	3479347181	CAP E SG 470uF/63V	RSR201	30291001910	RES MF 1K 1/5W F
CC212	3479347181	CAP E SG 470uF/63V	RC207	30291001910	RES MF 1K 1/5W F
CL212	3479347181	CAP E SG 470uF/63V	RL207	30291001910	RES MF 1K 1/5W F
			RR207	30291001910	RES MF 1K 1/5W F

## Parts List 2/8

SYMBOL	PART NO.	DESCRIPTION	SYMBOL	PART NO.	DESCRIPTION
RSL207	30291001910	RES MF 1K 1/5W F	RL227	30294300910	RES MF 430 1/5W F
RSR207	30291001910	RES MF 1K 1/5W F	RR227	30294300910	RES MF 430 1/5W F
RC226	30291201910	RES MF 1K2 1/5W F	RSL227	30294300910	RES MF 430 1/5W F
RL226	30291201910	RES MF 1K2 1/5W F	RSR227	30294300910	RES MF 430 1/5W F
RR226	30291201910	RES MF 1K2 1/5W F	RC211	30294302910	RES MF 43K 1/5W F
RSL226	30291201910	RES MF 1K2 1/5W F	RL211	30294302910	RES MF 43K 1/5W F
RSR226	30291201910	RES MF 1K2 1/5W F	RR211	30294302910	RES MF 43K 1/5W F
R244	3029122470	RES MF 1K2 1W J	RSL211	30294302910	RES MF 43K 1/5W F
R245	3029122470	RES MF 1K2 1W J	RSR211	30294302910	RES MF 43K 1/5W F
RSL212	30291501910	RES MF 1K5 1/5W F	RC214-220	30295600910	RES MF 560 1/5W F
RSR212	30291501910	RES MF 1K5 1/5W F	RL214-220	30295600910	RES MF 560 1/5W F
RC212	30291501910	RES MF 1K5 1/5W F	RR214-220	30295600910	RES MF 560 1/5W F
RL212	30291501910	RES MF 1K5 1/5W F	RSL214-220	30295600910	RES MF 560 1/5W F
RR212	30291501910	RES MF 1K5 1/5W F	RSR214-220	30295600910	RES MF 560 1/5W F
RC235	30291801910	RES MF 1K8 1/5W F	RC208	30296809910	RES MF 68 1/5W F
RL235	30291801910	RES MF 1K8 1/5W F	RL208	30296809910	RES MF 68 1/5W F
RR235	30291801910	RES MF 1K8 1/5W F	RR208	30296809910	RES MF 68 1/5W F
RSL235	30291801910	RES MF 1K8 1/5W F	RSL208	30296809910	RES MF 68 1/5W F
RSR235	30291801910	RES MF 1K8 1/5W F	RSR208	30296809910	RES MF 68 1/5W F
RC223-224	30292202910	RES MF 22K 1/5W F	R238	30296802910	RES MF 68K 1/5W F
RL223-224	30292202910	RES MF 22K 1/5W F	RC238	30296801910	RES MF 6K8 1/5W F
RR223-224	30292202910	RES MF 22K 1/5W F	RL238	30296801910	RES MF 6K8 1/5W F
RSL223-224	30292202910	RES MF 22K 1/5W F	RR238	30296801910	RES MF 6K8 1/5W F
RSR223-224	30292202910	RES MF 22K 1/5W F	RSL238	30296801910	RES MF 6K8 1/5W F
RC245	30292202910	RES MF 22K 1/5W F	RSR238	30296801910	RES MF 6K8 1/5W F
RL245	30292202910	RES MF 22K 1/5W F	RC205-206	30297500910	RES MF 750 1/5W F
RR245	30292202910	RES MF 22K 1/5W F	RL205-206	30297500910	RES MF 750 1/5W F
RSL245	30292202910	RES MF 22K 1/5W F	RR205-206	30297500910	RES MF 750 1/5W F
RSR245	30292202910	RES MF 22K 1/5W F	RSL205-206	30297500910	RES MF 750 1/5W F
RC236	30292001910	RES MF 2K 1/5W F	RSR205-206	30297500910	RES MF 750 1/5W F
RL236	30292001910	RES MF 2K 1/5W F	RC237	30299100910	RES MF 910 1/5W F
RR236	30292001910	RES MF 2K 1/5W F	RL237	30299100910	RES MF 910 1/5W F
RSL236	30292001910	RES MF 2K 1/5W F	RR237	30299100910	RES MF 910 1/5W F
RSR236	30292001910	RES MF 2K 1/5W F	RSL237	30299100910	RES MF 910 1/5W F
RC230	30293300910	RES MF 330 1/5W F	RSR237	30299100910	RES MF 910 1/5W F
RL230	30293300910	RES MF 330 1/5W F	RC233	3059027763	RES MPR 0.27X2 5W J
RR230	30293300910	RES MF 330 1/5W F	RL233	3059027763	RES MPR 0.27X2 5W J
RSL230	30293300910	RES MF 330 1/5W F	RR233	3059027763	RES MPR 0.27X2 5W J
RSR230	30293300910	RES MF 330 1/5W F	RSL233	3059027763	RES MPR 0.27X2 5W J
RC202	30293302910	RES MF 33K 1/5W F	RSR233	3059027763	RES MPR 0.27X2 5W J
RL202	30293302910	RES MF 33K 1/5W F	QC209	2008607106	TR NPN 2SC3424(O/Y)
RR202	30293302910	RES MF 33K 1/5W F	QL209	2008607106	TR NPN 2SC3425(O/Y)
RSL202	30293302910	RES MF 33K 1/5W F	QR209	2008607106	TR NPN 2SC3426(O/Y)
RSR202	30293302910	RES MF 33K 1/5W F	QSL209	2008607106	TR NPN 2SC3427(O/Y)
RC213	30293302910	RES MF 33K 1/5W F	QSR209	2008607106	TR NPN 2SC3428(O/Y)
RL213	30293302910	RES MF 33K 1/5W F	QC211	2028316100	TR NPN 2SC4883A-Y
RR213	30293302910	RES MF 33K 1/5W F	QL211	2028316100	TR NPN 2SC4883A-Y
RSL213	30293302910	RES MF 33K 1/5W F	QSL211	2028316100	TR NPN 2SC4883A-Y
RSR213	30293302910	RES MF 33K 1/5W F	QSR211	2028316100	TR NPN 2SC4883A-Y
RC239-242	30293909910	RES MF 39 1/5W F	QR211	2028316100	TR NPN 2SC4883A-Y
RL239-242	30293909910	RES MF 39 1/5W F	Q216	2238006104	TR NPN KRC107M
RR239-242	30293909910	RES MF 39 1/5W F	QC205-206	2208606108	TR NPN KTC3200(GR/BL)
RSL239-242	30293909910	RES MF 39 1/5W F	QL205-206	2208606108	TR NPN KTC3200(GR/BL)
RSR239-242	30293909910	RES MF 39 1/5W F	QR205-206	2208606108	TR NPN KTC3200(GR/BL)
R246	30293301910	RES MF 3K3 1/5W F	QSL205-206	2208606108	TR NPN KTC3200(GR/BL)
RC231-232	30293308910	RES MF 3R3 1/5W F	QSR205-206	2208606108	TR NPN KTC3200(GR/BL)
RL231-232	30293308910	RES MF 3R3 1/5W F	QC215	2208606108	TR NPN KTC3200(GR/BL)
RR231-232	30293308910	RES MF 3R3 1/5W F	QL215	2208606108	TR NPN KTC3200(GR/BL)
RSL231-232	30293308910	RES MF 3R3 1/5W F	QR215	2208606108	TR NPN KTC3200(GR/BL)
RSR231-232	30293308910	RES MF 3R3 1/5W F	QSL215	2208606108	TR NPN KTC3200(GR/BL)
RC227	30294300910	RES MF 430 1/5W F	QSR215	2208606108	TR NPN KTC3200(GR/BL)



## Parts List 3/8

SYMBOL	PART NO.	DESCRIPTION	SYMBOL	PART NO.	DESCRIPTION
QC208	2008207101	TR PNP 2SA1360(O/Y)	C03	3479333971	CAP E SG 3.3uF/50V
QL208	2008207101	TR PNP 2SA1360(O/Y)	C27	3479333971	CAP E SG 3.3uF/50V
QR208	2008207101	TR PNP 2SA1360(O/Y)	C26	3479347971	CAP E SG 4.7uF/50V
QSL208	2008207101	TR PNP 2SA1360(O/Y)	C28	3479347971	CAP E SG 4.7uF/50V
QSR208	2008207101	TR PNP 2SA1360(O/Y)	C41	3479347971	CAP E SG 4.7uF/50V
QC212	2028016100	TR PNP 2SA1859A-Y	C05	3479347031	CAP E SG 47uF/16V
QL212	2028016100	TR PNP 2SA1859A-Y	C11	3479347031	CAP E SG 47uF/16V
QR212	2028016100	TR PNP 2SA1859A-Y	C31	3679332120	CAP MYLAR 0.0033uF/100V J
QSL212	2028016100	TR PNP 2SA1859A-Y	C30	3679223120	CAP MYLAR 0.022uF/100V J
QSR212	2028016100	TR PNP 2SA1859A-Y	C48	3679223120	CAP MYLAR 0.022uF/100V J
QC201-204	2208206104	TR PNP KTA1268(GR/BL)	C32	3679393120	CAP MYLAR 0.039uF/100V J
QL201-204	2208206104	TR PNP KTA1268(GR/BL)	C15	3615471110	CAP POLY 470PF/50V J
QR201-204	2208206104	TR PNP KTA1268(GR/BL)	CP100	4428505416	CNT PLUG ST GIL-S-5P-S2T2-EF
QR201-204	2208206104	TR PNP KTA1268(GR/BL)	T03	2638231001	COIL AM IFT A7MC-K672713N4-KR
QSL201-204	2208206104	TR PNP KTA1268(GR/BL)	T02	2628231001	COIL AM OSC 7BR-K111027X2-KR
QSR201-204	2208206104	TR PNP KTA1268(GR/BL)	T01	2618231001	COIL AM-ANT1 M7ZN-K5643A-KR
QC207	2208206104	TR PNP KTA1268(GR/BL)	T04	2838501111	COIL FM-DET-A1 292BCA-K5713FKG
QL207	2208206104	TR PNP KTA1268(GR/BL)	T05	2838501112	COIL FM-DET-B1 292BCA-K5714X
QL207	2208206104	TR PNP KTA1268(GR/BL)	L01	2648601430	COIL INDUCTOR 20.8mH
QR207	2208206104	TR PNP KTA1268(GR/BL)	TL06	2658031001	COIL MPX LPF 253AGG-K5001-KR
QSL207	2208206104	TR PNP KTA1268(GR/BL)	TR06	2658031001	COIL MPX LPF 253AGG-K5001-KR
QSR207	2208206104	TR PNP KTA1268(GR/BL)	CN502	436208103524	CTG 0810 S08,T08 DL #26 P2.0
Q217	2208206104	TR PNP KTA1268(GR/BL)	D02	2058322101	DIODE 1N4148
<b>TUNER PCB ASSEMBLY</b>			VD01-VD02	2258817101	DIODE VARACTOR SVC321SPA-C
	4002002300	PCB TUNER 197*197 FR-1	ZD01	2258599519	DIODE ZENER T-72 UZ5V1
C04	3536103122	CAP C 2012 CHIP 0.01uF/50V J	ZD03	2258599519	DIODE ZENER T-72 UZ5V1
C07	3536103122	CAP C 2012 CHIP 0.01uF/50V J	CF04	3908001020	FILTER BFU450C4N
C23	3536103122	CAP C 2012 CHIP 0.01uF/50V J	CF01-CF03	3908011071	FILTER FM IF SFE10.7MA5
C10	3536101122	CAP C 2012 CHIP 100PF/50V J	FE01	3928101870	FRONT-END FTA4-460H
CLU52	3536100122	CAP C 2012 CHIP 10PF/50V J	IC04	2169202101	IC BU1920F RDS
CRU52	3536100122	CAP C 2012 CHIP 10PF/50V J	IC02	2168017128	IC LA1266 IF
CL50	3536121122	CAP C 2012 CHIP 120PF/50V J	IC03	2168417120	IC LA3401 MPX
CR50	3536121122	CAP C 2012 CHIP 120PF/50V J	IC01	2138017136	IC LM7001 PLL
C54	3536271122	CAP C 2012 CHIP 270PF/50V J	JLE/U100	4428804966	JUMPER HEADER 4P P2.5 H3.0
C36	3536331122	CAP C 2012 CHIP 330PF/50V J	JRE/U100	4428804966	JUMPER HEADER 4P P2.5 H3.0
C43	3536681122	CAP C 2012 CHIP 680PF/50V J	C01	3536223122	CAP C 2012 CHIP 0.022uF/50V J
CL52	3536680122	CAP C 2012 CHIP 68PF/50V J	C06	3536223122	CAP C 2012 CHIP 0.022uF/50V J
CR52	3536680122	CAP C 2012 CHIP 68PF/50V J	C12-C13	3536223122	CAP C 2012 CHIP 0.022uF/50V J
CLU50	3536820122	CAP C 2012 CHIP 82PF/50V J	C17-C18	3536223122	CAP C 2012 CHIP 0.022uF/50V J
CRU50	3536820122	CAP C 2012 CHIP 82PF/50V J	C21-C22	3536223122	CAP C 2012 CHIP 0.022uF/50V J
C38	3579101530	CAP C RADIAL 100PF/50V J	C24-C25	3536223122	CAP C 2012 CHIP 0.022uF/50V J
C16	3528150210	CAP C RADIAL 15PF/50V(CH) J	C29	3536223122	CAP C 2012 CHIP 0.022uF/50V J
C08-C09	3528180210	CAP C RADIAL 18PF/50V(CH) J	C34	3536223122	CAP C 2012 CHIP 0.022uF/50V J
C58-C59	3528270210	CAP C RADIAL 27PF/50V(CH) J	C40	3536223122	CAP C 2012 CHIP 0.022uF/50V J
C37	3579820530	CAP C RADIAL 82PF/50V J	C02	3536473122	CAP C 2012 CHIP 0.047uF/50V J
C57	3536104122	CAP CHIP 2012 0.1uF/50V J	C42	3536473122	CAP C 2012 CHIP 0.047uF/50V J
C46	3479322871	CAP E SG 0.22uF/50V		4448402966	JUMPER SHUNT 2P P2.5
C14	3479310131	CAP E SG 100uF/16V	J11,J20,J30	OPEN	OPEN
C35	3479310131	CAP E SG 100uF/16V	R16	3099101170	RES CHIP 2012 100 J
C44	3479310131	CAP E SG 100uF/16V	R34	3099101170	RES CHIP 2012 100 J
C20	3479310071	CAP E SG 10uF/50V	R39	3099101170	RES CHIP 2012 100 J
C39	3479310071	CAP E SG 10uF/50V	R01	3099104170	RES CHIP 2012 100K J
C49	3479310071	CAP E SG 10uF/50V	R04	3099104170	RES CHIP 2012 100K J
C53	3479310071	CAP E SG 10uF/50V	R06	3099104170	RES CHIP 2012 100K J
C55-C56	3479310071	CAP E SG 10uF/50V	R07	3099103170	RES CHIP 2012 10K J
CL51	3479310071	CAP E SG 10uF/50V	R27	3099103170	RES CHIP 2012 10K J
CR51	3479310071	CAP E SG 10uF/50V	R11	3099181170	RES CHIP 2012 180 J
C33	3479310971	CAP E SG 1uF/50V	R10	3099102170	RES CHIP 2012 1K J
C45	3479310971	CAP E SG 1uF/50V	R17-19	3099102170	RES CHIP 2012 1K J
C47	3479310971	CAP E SG 1uF/50V	R38	3099102170	RES CHIP 2012 1K J
			RL57	3099152170	RES CHIP 2012 1K5 J

## Parts List 4/8

SYMBOL	PART NO.	DESCRIPTION	SYMBOL	PART NO.	DESCRIPTION
RR57	3099152170	RES CHIP 2012 1K5 J	C118	3519103915	CAP C AXIAL 0.01uF/16V J
R35	3099182170	RES CHIP 2012 1K8 J	C100	3519473935	CAP C AXIAL 0.047uF/50V J
R29	3099220170	RES CHIP 2012 22 J	C112-C113	3519473935	CAP C AXIAL 0.047uF/50V J
R37	3099220170	RES CHIP 2012 22 J	C101-C104	3519101935	CAP C AXIAL 100PF/50V J
R28	3099223170	RES CHIP 2012 22K J	C106-107	3519101935	CAP C AXIAL 100PF/50V J
R41	3099223170	RES CHIP 2012 22K J	C119-C121	3519101935	CAP C AXIAL 100PF/50V J
R43	3099223170	RES CHIP 2012 22K J	C108-C111	3519821935	CAP C AXIAL 820PF/50V J
R08	3099271170	RES CHIP 2012 270 J	C114	3479310971	CAP E SG 1uF/50V
R21	3099271170	RES CHIP 2012 270 J	C117	3479347971	CAP E SG 4.7uF/50V
RR46	3099274170	RES CHIP 2012 270K J	CP109	4428502415	CNT PLUG AN GIL-S-2P-S2L2-EF
RR47	3099274170	RES CHIP 2012 270K J	CN403	436205403524	CTG 0540 S05,T05 DL #26 P2.0
RL46	3099274170	RES CHIP 2012 270K J	CN106	436208403524	CTG 0840 S08,T08 DL #26 P2.0
RL47	3099274170	RES CHIP 2012 270K J	CN104	436210083524	CTG 1008 S10,T10 DL #26 P2.0
RR48	3099272170	RES CHIP 2012 2K7 J	D101-D104	2058322101	DIODE 1N4148
RL48	3099272170	RES CHIP 2012 2K7 J	ESW102-103	3218000410	EC16B2420431(WITH DETENT)
R56	3099225170	RES CHIP 2012 2M2 J	ESW101	3218000310	EC16B243040H(W/O DETENT)
R20	3099331170	RES CHIP 2012 330 J	FIP100	2328000302	FIP SVR08LM02(LEAD 15MM)
R13	3099332170	RES CHIP 2012 3K3 J		6715000620	SPONGE FIP(30x15X5T)RSX972
R33	3099332170	RES CHIP 2012 3K3 J	IC100	2138322010	IC OTP CXP828P60Q-1
R42	3099332170	RES CHIP 2012 3K3 J	J???	1508400602	JUMPER
RL49	3099332170	RES CHIP 2012 3K3 J	RMC101	2408000190	REMOCON SENSOR SBX3010-52B
RR49	3099332170	RES CHIP 2012 3K3 J	R127-R142	3099124170	RES CHIP 2012 120K J
R31	3099392170	RES CHIP 2012 3K9 J	R114-R119	3029103970	RES MF 10K 1/8W J
R05	3099471170	RES CHIP 2012 470 J	R121	3029181970	RES MF 180 1/8W J
R15	3099471170	RES CHIP 2012 470 J	R101-R104	3029102970	RES MF 1K 1/8W J
R22	3099471170	RES CHIP 2012 470 J	R123-R126	3029102970	RES MF 1K 1/8W J
R26	3099473170	RES CHIP 2012 47K J	R120	3029470970	RES MF 47 1/8W J
R36	3099473170	RES CHIP 2012 47K J	R105-R108	3029473970	RES MF 47K 1/8W J
R40	3099473170	RES CHIP 2012 47K J	R110-R113	3029473970	RES MF 47K 1/8W J
R44	3099473170	RES CHIP 2012 47K J	R122	3029472970	RES MF 4K7 1/8W J
R24	3099472170	RES CHIP 2012 4K7 J	SW117-132	4658000210	SW TACT SKHVBHD010
R30	3099472170	RES CHIP 2012 4K7 J	X101	3938124010	RESONATOR CST10.0MTW-TF01
R09	3099561170	RES CHIP 2012 560 J	Q101	2208606104	TR NPN KTC3198Y-AT
R12	3099561170	RES CHIP 2012 560 J			<b>KEY B'D PCB ASSEMBLY (PCB FRONT)</b>
R14	3099561170	RES CHIP 2012 560 J		4002002410	PCB KEY B'D ( PCB Front )
R02	3099562170	RES CHIP 2012 5K6 J	CP104	4428510416	CNT PLUG ST GIL-S-10P-S2T2-EF
R32	3099562170	RES CHIP 2012 5K6 J	SW101-116	4658000210	SW TACT SKHVBHD010
R03	3099623170	RES CHIP 2012 62K J			<b>POWER SW B'D PCB ASSEMBLY (PCB FRONT)</b>
R50	3099681170	RES CHIP 2012 680 J		4002002420	POWER SW B'D ( PCB Front )
R25	3099683170	RES CHIP 2012 68K J	CS100	3549472109	CAP C 0.0047UF/400V AC
X02	3938131600	RESONATOR CSB-456F15	CNT105	436502402147	CTJ 0240 201,210 DL #22 P7.92
J???	1508400602	TAPING JUMPER 0.6mm	SW100	4628000110	SW PWR SDDL15700
ANT01	4408000320	TERMINAL ANT(GND),SC0210586N			<b>SUB-D1 B'D PCB ASSEMBLY (PCB FRONT)</b>
QL08	2238422100	TR NPN DTC323TSTP		4002002430	SUB-D1 B'D ( PCB Front )
QR08	2238422100	TR NPN DTC323TSTP	CP200-CP201	4428811526	CNT BtoB HOUSING MO 42140-2211
Q03	2208406103	TR NPN KTC3194Y(KTC1923Y)	CP202	4428807526	CNT BtoB HOUSING MO 42140-2207
Q01-Q02	2208606104	TR NPN KTC3198Y-AT	IC203	2168020107	IC NJU7312AL ANALOG SWICH
Q07	2208606104	TR NPN KTC3198Y-AT			<b>SUB-D2 B'D PCB ASSEMBLY (PCB FRONT)</b>
Q04-06	2238006103	TR PNP KRA107M		4002002440	SUB-D2 B'D ( PCB Front )
Q09	2238006103	TR PNP KRA107M	CPT600-601	4428811526	CNT BtoB HOUSING MO 42140-2211
TC01	3838001000	TRIMMER 10PF TZ03-T110FR(WHT)	CPT602	4428807526	CNT BtoB HOUSING MO 42140-2207
VR03	3248022443	VR SEMI 220K(B)-H RH063MCJ5R	IC606	2168020109	IC TC9163AN ANALOG SWITCH
VR02	3248047343	VR SEMI 47K(B)-H RH063MCS4R			<b>SUB-D3 B'D PCB ASSEMBLY (PCB FRONT)</b>
VR01	3248047243	VR SEMI 4K7(B)-H RH063MCS3R		4002002450	SUB-D3 B'D ( PCB Front )
X03	3908111690	X-TAL 4.332MHZ	CP200A-201A	4428811526	CNT BtoB HOUSING MO 42140-2211
X01	3908101030	X-TAL 7.2MHZ	CP202A	4428807526	CNT BtoB HOUSING MO 42140-2207
		<b>CONTROL B'D PCB ASSEMBLY (PCB FRONT)</b>			
	4002002400	PCB FRONT 330*247 X1 FR1			
	6515000110	HOLDER FL, ABS BLACK XR-401			
C115	3519103915	CAP C AXIAL 0.01uF/16V J			

## Parts List 5/8

SYMBOL	PART NO.	DESCRIPTION	SYMBOL	PART NO.	DESCRIPTION
IC204	2168020107	IC NJU7312AL ANALOG SWICH	C951-C954	3679473120	CAP MYLAR 0.047uF100V J
<b>GUIDE B'D PCB ASSEMBLY (PCB FRONT)</b>			C967-C970	3679472120	CAP MYLAR 0.0047uF100V J
	4002002470	GUIDE B'D ( PCB Front )	CT202	4428502646	CNT PLUG ST JE202A-1 T-2 P3.96
J272-J277	1508400602	JUMPER	CT910	4428502646	CNT PLUG ST JE202A-1 T-2 P3.96
<b>GUIDE B'D PCB ASSEMBLY (PCB FRONT)</b>			CT203	4428503646	CNT PLUG ST JE202A-1 T-3 P3.96
	4002002480	GUIDE B'D ( PCB Front )	CT911	4428503646	CNT PLUG ST JE202A-1 T-3 P3.96
J266-J271	1508400602	JUMPER	CNT951	436502132166	CTJ 0213 201,210 DL #18 P3.96
<b>S-VIDEO B'D PCB ASSEMBLY (PCB FRONT)</b>				4002002600	PCB SPEAKER 197*163 FR1
	4002002460	S-VIDEO B'D ( PCB Front)	R951-R954	3029100570	RES MF 10 2W J
C601-C602	3479310123	CAP E SG 100uF/10V	JAK951-952	4408101010	SPEAKER TERMINAL 4P(RB,RB)
C603-C604	3519104935	CAP C AXIAL 0.1uF/50V J	J19-J20	1508400602	TAPING JUMPER 0.6mm
C605-C606	3479310123	CAP E SG 100uF/10V	<b>CENTER SPKR B'D PCB ASSEMBLY (PCB SPEAKER)</b>		
C607-C608	3519104935	CAP C AXIAL 0.1uF/50V J	C966	3679472120	CAP MYLAR 0.0047UF100V J
C609-C612	3479347041	CAP E SG 47uF/25V	C955	3679473120	CAP MYLAR 0.047UF/100V J
C613-C620	3479310123	CAP E SG 100uF/10V	CT951	4428502646	CNT PLUG ST JE202A-1 T-2 P3.96
C621	3479347121	CAP E SG 470uF/10V	R955	3029100570	RES MF 10 2W J
C622	3479310123	CAP E SG 100uF/10V		4002002610	CENTER B'D PCB ( PCB SPEAKER )
C623	3479347121	CAP E SG 470uF/10V	JAK953	4408101110	SPEAKER TERMINAL2P(R,B)
C624	3479310123	CAP E SG 100uF/10V	<b>TERMINAL B'D PCB ASSEMBLY (PCB SPEAKER)</b>		
C625	3479347121	CAP E SG 470uF/10V		4002002620	TERMINAL B'D PCB ( PCB Speaker )
C626	3479310123	CAP E SG 100uF/10V	C867	3519104935	CAP C AXIAL 0.1uF/50V J
C627	3479347121	CAP E SG 470uF/10V	C869	3519104935	CAP C AXIAL 0.1uF/50V J
C628	3479310123	CAP E SG 100uF/10V	C161-C166	3519101935	CAP C AXIAL 100PF/50V J
C629	3519103915	CAP C AXIAL 0.01uF/16V J	C863-C866	3479310123	CAP E SG 100uF/10V
C630	3479322971	CAP E SG 2.2uF/50V	C868	3479310123	CAP E SG 100uF/10V
C631	3479310971	CAP E SG 1uF/50V	C861-C862	3479347041	CAP E SG 47uF/25V
C632	3479310071	CAP E SG 10uF/50V	CN407	436211163524	CTG 1116 S11,T11 DL #26 P2.0
CN404	436209143524	CTG 0914 S09,T09 DL #26 P2.0	D181-183	2058322101	DIODE 1N4148
CNP600-CNP601	4428811620	CNT PIN BASE 11P P2.5 H20	CP108	4428503416	CNT PLUG ST GIL-S-3P-S2T2-EF
CNP602	4428807620	CNT PIN BASE 7P P2.5 H20	CP107	4428505416	CNT PLUG ST GIL-S-5P-S2T2-EF
CP601	4428510416	CNT PLUG ST GIL-S-10P-S2T2-EF	CP602	4428508416	CNT PLUG ST GIL-S-8P-S2T2-EF
D601-D604	2058322101	DIODE 1N4148	IC861	2168020109	IC TC9163AN ANALOG SWITCH
IC601	2168020109	IC TC9163AN ANALOG SWITCH	IC862	2169525001	IC TSH94IN QUAD VIDEO AMP
IC602-603	2169525001	IC TSH94IN QUAD VIDEO AMP	JAK957-959	4438300210	JACK 2P( $\phi$ 3.5)HSJ1002-01-1020
J???	1508400602	JUMPER	JAK955	4438100920	JACK RCA 2P (B,B WOOFER)
JK601-JK603	4438500220	JACK S-VIDEO 3P YKF51-5520	JAK956	4438100120	JACK RCA 2P(W,R)
Q600	2208206120	TR PNP KTA1271	JAK954	4438100220	JACK RCA 4P(WW,RR)
Q601	2208206105	TR PNP KTA1266Y	JAK960	4438101220	JACK RCA 9P(GR,BL,R)
Q602	2238006103	TR PNP KRA107M	IC101,IC103	2408000136	OPTO. COUPLER LTV-817
Q603-Q605	2238006104	TR NPN KRC107M	R185-R186	3029100970	RES MF 10 1/8W J
R600	3029470970	RES MF 47 1/8W J	R180-R181	3029101970	RES MF 100 1/8W J
R601-R616	3029750970	RES MF 75 1/8W J	R874	3029101970	RES MF 100 1/8W J
R617-R618	3029680970	RES MF 68 1/8W J	R880	3029101970	RES MF 100 1/8W J
R627-R630	3029221970	RES MF 220 1/8W J	R886	3029101970	RES MF 100 1/8W J
R631	3029333970	RES MF 33K 1/8W J	R157-R162	3029104970	RES MF 100K1/8W J
R632	3029222970	RES MF 2K2 1/8W J	R873	3029103970	RES MF 10K 1/8W J
R633	3029560970	RES MF 56 1/8W J	R879	3029103970	RES MF 10K 1/8W J
R634	3029473970	RES MF 47K 1/8W J	R885	3029103970	RES MF 10K 1/8W J
R635	3029272970	RES MF 2K7 1/8W J	R167-172	3029102970	RES MF 1K 1/8W J
R637	3029123970	RES MF 12K 1/8W J	R183-R184	3029102970	RES MF 1K 1/8W J
R638	3029103970	RES MF 10K 1/8W J	R871-R872	3029102970	RES MF 1K 1/8W J
R639	3029181970	RES MF 180 1/8W J	R877-R878	3029102970	RES MF 1K 1/8W J
R641-R648	3029101970	RES MF 100 1/8W J	R883-R884	3029102970	RES MF 1K 1/8W J
R649-R656	3029103970	RES MF 10K 1/8W J	R887	3029102970	RES MF 1K 1/8W J
R657-R672	3029102970	RES MF 1K 1/8W J	R867-R868	3029221970	RES MF 220 1/8W J
R673-R674	3029103970	RES MF 10K 1/8W J	R869	3029223970	RES MF 22K 1/8W J
<b>SPEAKER B'D PCB ASSEMBLY (PCB SPEAKER)</b>			R875	3029223970	RES MF 22K 1/8W J
			R881	3029223970	RES MF 22K 1/8W J
			R193-R194	3029472970	RES MF 4K7 1/8W J

## Parts List 6/8

SYMBOL	PART NO.	DESCRIPTION	SYMBOL	PART NO.	DESCRIPTION
R861-R866	3029750970	RES MF 75 1/8W J	C921	3479347071	CAP E SG 47uF/50V
R870	3029750970	RES MF 75 1/8W J	C922-934	3679103120	CAP MYLAR 0.01uF/100V J
R876	3029750970	RES MF 75 1/8W J	CP900	4428525810	CNT LV PIN BASE 1P
R882	3029750970	RES MF 75 1/8W J	CN200	4428811627	CNT PIN BASE 11P P2.5 H27
J???	1508400602	TAPING JUMPER 0.6mm	CN201	4428811627	CNT PIN BASE 11P P2.5 H27
<b>MAIN PCB ASSEMBLY</b>			CN202	4428807627	CNT PIN BASE 7P P2.5 H27
	4002002500	PCB MAIN 330*247 X1 FR1	CP906	4428502526	CNT PLUG ST MO 5267-02
C825	3579103530	CAP C RADIAL 0.01uF/50V J	CP903	4428503526	CNT PLUG ST MO 5267-03
C200	3579223530	CAP C RADIAL 0.022uF/50V J	CP908	4428503526	CNT PLUG ST MO 5267-03
C814-815	3579104530	CAP C RADIAL 0.1uF/50V J	CP904	4428507526	CNT PLUG ST MO 5267-07
C828	3579104530	CAP C RADIAL 0.1uF/50V J	CN901	436202083524	CTG 0208 S02,T02 DL #26 P2.0
C832	3579104530	CAP C RADIAL 0.1uF/50V J	CN108	436203203524	CTG 0320 S03,T03 DL #26 P2.0
C917	3579104530	CAP C RADIAL 0.1uF/50V J	CN405	436204103524	CTG 0410 S04,T04 DL #26 P2.0
C201-248	3579101530	CAP C RADIAL 100PF/50V J	CN100	436205123524	CTG 0512 S05,T05 DL #26 P2.0
C267-268	3579101530	CAP C RADIAL 100PF/50V J	CN107	436205263524	CTG 0526 S05,T05 DL #26 P2.0
C273-274	3579101530	CAP C RADIAL 100PF/50V J	CN602	436208143524	CTG 0814 S08,T08 DL #26 P2.0
C289-290	3579101530	CAP C RADIAL 100PF/50V J	CN601	436210103524	CTG 1010 S10,T10 DL #26 P2.0
C295-296	3579101530	CAP C RADIAL 100PF/50V J	CN402	436212103524	CTG 1210 S12,T12 DL #26 P2.0
C301-302	3579101530	CAP C RADIAL 100PF/50V J	CN401	436215103524	CTG 1510 S15,T15 DL #26 P2.0
C357-359	3579101530	CAP C RADIAL 100PF/50V J	D901-914	2258128002	DIODE 1N4004
C362-365	3579101530	CAP C RADIAL 100PF/50V J	D918	2258128002	DIODE 1N4004
C824	3579101530	CAP C RADIAL 100PF/50V J	D801-803	2058322101	DIODE 1N4148
C829	3579101530	CAP C RADIAL 100PF/50V J	D915-917	2058322101	DIODE 1N4148
C830-831	3528330210	CAP C RADIAL 33PF/50V(CH) J	D919	2058322101	DIODE 1N4148
C819-820	3528560210	CAP C RADIAL 56PF/50V(CH) J	D930	2058322101	DIODE 1N4148
C826	3479347871	CAP E SG 0.47uF/50	D922	2258599120	DIODE ZENER T-72 UZ12V
C906	3409310331	CAP E SG 10000uF/16V	D920	2258599270	DIODE ZENER T-72 UZ27V
C901	3419510241	CAP E SG 1000uF/25V	D923	2258599439	DIODE ZENER T-72 UZ4V3
C805-808	3479310123	CAP E SG 100uF/10V	D921	2258599919	DIODE ZENER T-72 UZ9V1
C812-813	3479310123	CAP E SG 100uF/10V	D924	2258599919	DIODE ZENER T-72 UZ9V1
C816-817	3479310123	CAP E SG 100uF/10V	D932	2258599919	DIODE ZENER T-72 UZ9V1
C827	3479310123	CAP E SG 100uF/10V	CP905	4428504416	CNT PLUG ST GIL-S-4P-S2T2-EF
C833	3479310123	CAP E SG 100uF/10V	CP106	4428508416	CNT PLUG ST GIL-S-8P-S2T2-EF
C909	3479310131	CAP E SG 100uF/16V	F903-904	5508322433	FUSE LT5 T2A/250V RADIAL
C809	3479310071	CAP E SG 10uF/50V	GND01	4235007410	GND PLATE MET37-0002
C919	3479310071	CAP E SG 10uF/50V	HS1	7505000310	H/SINK REG TR (46X12X30)
C821-822	3479310971	CAP E SG 1uF/50V	HS2	7505000330	H/SINK REG TR (46X12X60)
C910-916	3479310971	CAP E SG 1uF/50V	HS4	7505000330	H/SINK REG TR (46X12X60)
C823	3479322971	CAP E SG 2.2uF/50V	IC901-903	2168602105	IC KIA7805P REG.
C904-905	3409322231	CAP E SG 2200uF/16V	IC905	2168602106	IC KIA7806PI REG
C908	3479322141	CAP E SG 220uF/25V	IC907	2168602109	IC KIA7815PI REG.
C920	3479322071	CAP E SG 22uF/50V	IC904	2168602113	IC KIA7906PI MOLD REG
C902-903	3409333261	CAP E SG 3300uF/35V	IC906	2168602115	IC KIA7915PI MOLD REG
C265-266	3479347971	CAP E SG 4.7uF/50V	IC801	2168222113	IC KS5520 OSD
C271-272	3479347971	CAP E SG 4.7uF/50V	IC205-209	2168220135	IC NJM5532D DUAL OPAMP
C275-277	3479347971	CAP E SG 4.7uF/50V	IC302-303	2168220135	IC NJM5532D DUAL OPAMP
C288	3479347971	CAP E SG 4.7uF/50V	IC201-202	2168020107	IC NJU7312AL ANALOG SWICH
C291-294	3479347971	CAP E SG 4.7uF/50V	IC802	2168020109	IC TC9163AN ANALOG SWITCH
C297-300	3479347971	CAP E SG 4.7uF/50V	IC301	2138007110	IC TC9459N DIP ELEC. VOL
C303-304	3479347971	CAP E SG 4.7uF/50V	IC803	2169525001	IC TSH94IN QUAD VIDEO AMP
C355-356	3479347971	CAP E SG 4.7uF/50V	L802	2648610082	INDUCTOR AXIAL LAL02TB 100K
C360-361	3479347971	CAP E SG 4.7uF/50V	L801	2648610182	INDUCTOR AXIAL LAL02TB 101K
C366-367	3479347971	CAP E SG 4.7uF/50V	JK801-803	4438100520	JACK RCA 3P(Y)
C801-804	3479347121	CAP E SG 470uF/10V	JK201	4438100220	JACK RCA 4P(WW,RR)
C935	3479347121	CAP E SG 470uF/10V	JK202-204	4438100320	JACK RCA 6P(WWW,RRR)
C249-264	3479347041	CAP E SG 47uF/25V	R843	3029100970	RES MF 10 1/8W J
C351-354	3479347041	CAP E SG 47uF/25V	R808-810	3029101970	RES MF 100 1/8W J
C368-369	3479347041	CAP E SG 47uF/25V	R802	3029101970	RES MF 100 1/8W J
C810-811	3479347041	CAP E SG 47uF/25V	R249-250	3029104970	RES MF 100K1/8W J
C918	3479347041	CAP E SG 47uF/25V	R253-254	3029104970	RES MF 100K1/8W J
			R259-260	3029104970	RES MF 100K1/8W J



## Parts List 7/8

SYMBOL	PART NO.	DESCRIPTION	SYMBOL	PART NO.	DESCRIPTION
R265-266	3029104970	RES MF 100K1/8W J	R826	3029470970	RES MF 47 1/8W J
R271-272	3029104970	RES MF 100K1/8W J	R854	3029470970	RES MF 47 1/8W J
R277-278	3029104970	RES MF 100K1/8W J	R907	3029470970	RES MF 47 1/8W J
R283-284	3029104970	RES MF 100K1/8W J	R902-903	3029470970	RES MF 47 1/8W J
R289-290	3029104970	RES MF 100K1/8W J	R909	3029470970	RES MF 47 1/8W J
R295-296	3029104970	RES MF 100K1/8W J	R912	3029470970	RES MF 47 1/8W J
R301-302	3029104970	RES MF 100K1/8W J	R251-252	3029472970	RES MF 4K7 1/8W J
R357-358	3029104970	RES MF 100K1/8W J	R261-262	3029472970	RES MF 4K7 1/8W J
R368-369	3029104970	RES MF 100K1/8W J	R273-274	3029472970	RES MF 4K7 1/8W J
R374-375	3029104970	RES MF 100K1/8W J	R285-286	3029472970	RES MF 4K7 1/8W J
R838	3029104970	RES MF 100K1/8W J	R297-298	3029472970	RES MF 4K7 1/8W J
R801	3029103970	RES MF 10K 1/8W J	R306	3029472970	RES MF 4K7 1/8W J
R803	3029103970	RES MF 10K 1/8W J	R359-360	3029472970	RES MF 4K7 1/8W J
R811-813	3029103970	RES MF 10K 1/8W J	R372-373	3029472970	RES MF 4K7 1/8W J
R911	3029103970	RES MF 10K 1/8W J	R379	3029472970	RES MF 4K7 1/8W J
R821	3029121970	RES MF 120 1/8W J	R841	3029472970	RES MF 4K7 1/8W J
R800	3029123970	RES MF 12K 1/8W J	R905	3029472970	RES MF 4K7 1/8W J
R834	3029181970	RES MF 180 1/8W J	R824-825	3029563970	RES MF 56K 1/8W J
R847	3029181970	RES MF 180 1/8W J	R840	3029512970	RES MF 5K1 1/8W J
R201-224	3029102970	RES MF 1K 1/8W J	R827	3029680970	RES MF 68 1/8W J
R232-236	3029102970	RES MF 1K 1/8W J	R822-823	3029682970	RES MF 6K8 1/8W J
R247-248	3029102970	RES MF 1K 1/8W J	R921	3029682970	RES MF 6K8 1/8W J
R257-258	3029102970	RES MF 1K 1/8W J	R804-807	3029750970	RES MF 75 1/8W J
R267-270	3029102970	RES MF 1K 1/8W J	R849-853	3029750970	RES MF 75 1/8W J
R279-282	3029102970	RES MF 1K 1/8W J	Q301-302	2238422100	TR NPN DTC323TSTP
R291-294	3029102970	RES MF 1K 1/8W J	Q201-208	2238422100	TR NPN DTC323TSTP
R303-305	3029102970	RES MF 1K 1/8W J	Q213	2208606104	TR NPN KTC3198Y-AT
R355	3029102970	RES MF 1K 1/8W J	Q304	2208606104	TR NPN KTC3198Y-AT
R356	3029102970	RES MF 1K 1/8W J	Q902-905	2208606104	TR NPN KTC3198Y-AT
R361-363	3029102970	RES MF 1K 1/8W J	Q803-804	2208606120	TR NPN KTC3203
R366-367	3029102970	RES MF 1K 1/8W J	Q209-212	2238006103	TR PNP KRA107M
R370-371	3029102970	RES MF 1K 1/8W J	Q303	2238006103	TR PNP KRA107M
R376-377	3029102970	RES MF 1K 1/8W J	Q901	2208206105	TR PNP KTA1266Y
R814-820	3029102970	RES MF 1K 1/8W J	Q801-802	2208206120	TR PNP KTA1271
R835-837	3029102970	RES MF 1K 1/8W J	Q805	2208206120	TR PNP KTA1271
R855-857	3029102970	RES MF 1K 1/8W J	X801	3938201950	X-TAL 14.31818MHZ
R904	3029102970	RES MF 1K 1/8W J			
R906	3029102970	RES MF 1K 1/8W J			
R910	3029102970	RES MF 1K 1/8W J			
R923	3029102970	RES MF 1K 1/8W J			
R845	3029122970	RES MF 1K2 1/8W J			
R924	3029152970	RES MF 1K5 1/8W J			
R255-256	3029182970	RES MF 1K8 1/8W J			
R846	3029105970	RES MF 1M 1/8W J			
R848	3029109970	RES MF 1R 1/8W J			
R913-914	3029109970	RES MF 1R 1/8W J			
RW905	3029109470	RES MF 1R 1W J			
R839	3029204970	RES MF 200K 1/8W J			
R830,831	3029220970	RES MF 22 1/8W J			
R901	3029220470	RES MF 22 1W J			
R225-230	3029221970	RES MF 220 1/8W J			
R237-246	3029221970	RES MF 220 1/8W J			
R351-354	3029221970	RES MF 220 1/8W J			
R364-365	3029221970	RES MF 220 1/8W J			
R832-833	3029221970	RES MF 220 1/8W J			
R842	3029223970	RES MF 22K 1/8W J			
R828-829	3029222970	RES MF 2K2 1/8W J			
R908	3029222970	RES MF 2K2 1/8W J			
RW901-904	3029229470	RES MF 2R2 1W J			
R378	3029332970	RES MF 3K3 1/8W J			
R844	3029392970	RES MF 3K9 1/8W J			

Parts List (8/8)

SYMBOL	PARTS NO.	DESCRIPTION	SYMBOL	PARTS NO.	DESCRIPTION
<b>DIGITAL BOARD PCB ASSEMBLY</b>					
L401-405,L503-505	4002002800	PCB DIGITAL	IC402	2408008001	OPTO JACK TOTX178A
L501,L502	2648702148	BEAD COIL CHIP 2012 CIM 21J 102	R526,528,535-536,539,C417,C422	3099000170	RES CHIP 2012 0R J
C553	2648702149	BEAD COIL CHIP 2012 CIM 21P 110	R425,428,431,436,452-455,508	3099100170	RES CHIP 2012 10 J
C402,406,410,418,423,C514,	3439210415	CAP BACK-UP 0.1F/5.5V	R404,411,418,435,438-444,	3099101170	RES CHIP 2012 100 J
CSW502,503	3536223122	CAP C 2012 CHIP 0.022UF/50V J	513-515,552,RA401,402		
CSW706,710	3536563122	CAP C 2012 CHIP 0.056UF/50V J	RC714,RF715,RS710,RSW725,	3099104170	RES CHIP 2012 100K J
CAL/R404,CAL/R406,CD501,	3536101122	CAP C 2012 CHIP 100PF/50V J	RF716,RS711,RC715,RSW726,		
CDL/R502,CFL/R505,CFL/R703-704,			RF716,RS711,RC715,RSW726,		
CML/R702-703,CC505,702,703,707			R405,412,419,RC507,702,705, 707,	3099104170	RES CHIP 2012 100K J
708,CS/R505,CSL/R702-703,			709,712,RDL/R501,RDL/R503,		
C404,408,412,CAL/R408,CSW707	3536222122	CAP C 2012 CHIP 2200PF/50V J	RFL/R507,RFL/R703,RFL/R706,		
CSL/R502-503,CFL/R502-503,	3536271122	CAP C 2012 CHIP 270PF/50V J	RFL/R708-709,RFL/R711,RFL/R720,		
CC502-503			RML/R702,RML/R704,RSL/R507,		
C443,444,CFL/R713	3536270122	CAP C 2012 CHIP 27PF/50V J	RSL/R702,RSL/R705,RSL/R707,		
CFL/R501,CSL/R501,CC501,	3536331122	CAP C 2012 CHIP 330PF/50V J	RSL/R709,RSL/R712,RSW507,702,		
C411,C407,C403	3536470122	CAP C 2012 CHIP 47PF/50V J	704,707,710,712, 715,716,718,720,		
CSW711	3536822122	CAP C 2012 CHIP 8200PF/50V J	723		
C415,419,421,424,426,427,432,	3536104122	CAP CHIP 2012 0.1UF/50V J	R407,410,414,417,421,424,426,	3099103170	RES CHIP 2012 10K J
433,435,438,440,442,446-449,450-			R427,429,430,451,500-507,510,		
454,500-513,515,518,519,522-524,			516,518,519,521,522,524,531-533,		
554,703,704,CAL/R402,CC710,			561-562,567-573,RAL/R401,402,		
CCW501,503,505,506,510,CD506,			RAL/R404,RC703,RSL/R703,		
507,CF501,503,505,506,510,CS501			EML/R703,RSW703,714,R574		
503,505,506,510,707,709,			RSW721	3099183170	RES CHIP 2012 18K J
C552	3479322871	CAP E SG 0.22UF/50V	R409,416,423,R558,703-705,	3099102170	RES CHIP 2012 1K J
C420,425,428,434,436,437,439, 441,	3479310071	CAP E SG 10uF/50V	RF707,712-714,RC506,701,706,708,		
CAL/R401,CAL/R403,CC504,701,			713,RFL/R701-702,RFL/R707,		
CC704-706,CC709,CDL/R501,			RFL/R710,RML/R701,RCW705-707,		
CDL/R503,CFL/R504,CFL/R701-702,			RS705-707,RSLR506,RSL/R701,		
CFL/R705-708,CFL/R715,CML/R701,			RSL/R706,RSL/R708,RSL/R713,		
CML/R704,CSL/R504,CSL/R701,			RF705,706,RSW506,701,705,706		
CSL/R704,			711,717,719,724		
CS509,CF509,CCW509,C445	3479310071	CAP E SG 10uF/50V	RFL/R717	3099122170	RES CHIP 2012 1K2 J
C520,C521,CFL/R714	3479310971	CAP E SG 1uF/50V	RSW722	3099182170	RES CHIP 2012 1K8 J
C517	3479322971	CAP E SG 2.2UF/50V	R406,413,420,432,433,701,702,	3099221170	RES CHIP 2012 220 J
C551	3479333971	CAP E SG 3.3UF/50V	RC508,509,RCW701-704,708,		
CA401,402,C516,CCW502,504,	3479347041	CAP E SG 47uF/25V	709,RD501-507,RF501,502,		
507,508,701-706,CM701,702,CD502,			701-704,708,709,RM701,702,RS501,		
503,CS502,504,CS507,508,CS701-			502,701-704,708,709		
706,CD504,505,CF502,504,507,508,			RFL/R715	3099273170	RES CHIP 2012 27K J
701-708,C701,702,CSW730,731			RFL/R721-722	3099222170	RES CHIP 2012 2K2 J
CFL/R711	3679272120	CAP MYLAR 0.0027UF/100V J	RAL/R408-409,R434	3099331170	RES CHIP 2012 330 J
CFL/R710	3679123120	CAP MYLAR 0.012UF/100V J	RFL/R712	3099393170	RES CHIP 2012 39K J
CFL/R712	3679223120	CAP MYLAR 0.022UF/100V J	RSL/R711,RC711,RSW709	3099392170	RES CHIP 2012 3K9 J
CFL/R709	3679683120	CAP MYLAR 0.068UF/100V J	RFL/R718	3099474170	RES CHIP 2012 470K J
CP407	4428511416	CNT PLUG ST GIL-S-11P-S2T2-EF	RAL/R403	3099473170	RES CHIP 2012 47K J
CP551	4428512416	CNT PLUG ST GIL-S-12P-S2T2-EF	R408,415,422,511,512,517,520, 551,	3099472170	RES CHIP 2012 4K7 J
CP554	4428515416	CNT PLUG ST GIL-S-15P-S2T2-EF	RAL/R405-407,RDL/R502,		
CP557	4428502416	CNT PLUG ST GIL-S-2P-S2T2-EF	RFL/R704-705,713,RSL/R704,RC704,		
CP555	4428504416	CNT PLUG ST GIL-S-4P-S2T2-EF	RSW713,R554-557		
CP553	4428505416	CNT PLUG ST GIL-S-5P-S2T2-EF	RSW730,731	3099560170	RES CHIP 2012 56 J
CP556	4428508416	CNT PLUG ST GIL-S-8P-S2T2-EF	RF503,RS503,RC510,RF710,711	3099561170	RES CHIP 2012 560 J
CP552	4428509416	CNT PLUG ST GIL-S-9P-S2T2-EF	RFL/R714	3099564170	RES CHIP 2012 560K J
CN406 (NOTE! CURRENT)	436210307724	CTG 1030 S10,T10 DL #26 P2.0 SHIELD	R446,RC501-505,RFL/R501-505,	3099562170	RES CHIP 2012 5K6 J
SILK: CP406			RSL/R501-505,RSW501-505,		
D551-556,D558	2257103110	DIODE CHIP KDS184RTK	RFL/R716,		
D400-403	2257104100	DIODE CHIP KDS226RTK	RSW713	3099682170	RES CHIP 2012 6K8 J
IC412-413, IC504	2108019128	IC 74HCT125	R401-403	3099750170	RES CHIP 2012 75 J
IC403-405,407	2138001135	IC 74HCU04	RFL/R719	3099823170	RES CHIP 2012 82K J
IC501-502	2109001150	IC 74VHC 574M	R445,RSW708,RSL/R710,RC710,	3099912170	RES CHIP 2012 9K1 J
IC414	2109001100	IC 74VHC157M--210802112 74HC157	RSW714		
IC411	2139214001	IC AK4110-96kHz/24bit DIR	XT551	3938124010	RESONATOR CST10.0MTW-TF01
IC506-508	2139214003	IC AK4324-96kHz/24bit DAC	Q400-404,555	2207606010	TR CHIP NPN KRC107S
IC410	2139214002	IC AK5351-20bit ADC	Q551-554,OC703,QFL/R701,	2207606011	TR CHIP NPN KRC231S
IC503	2138408003	IC AT27C020-70PC PROM	<b>QSL/R701,QSW703,Q556</b>		
IC514	2168639100	IC BA033FP-E2 REG.	QSW703,Q556		
IC505	2138112002	IC CS492604-CL	QC702,QF702,QS702,QSW702	2207206010	TR CHIP PNP KRA107S
IC408-409,IC509-512,IC701-705,	2168220142	IC NJM5532M DUAL OPAMP	XT401	3908101130	X-TAL 12.288MHZ
IC710-712					
IC513,713	2168020108	IC NJU7311AM ANALOG SWICH			
IC709	2138007130	IC TC9184P ELECT TONE			
IC706-708	2138007120	IC TC9459F ELECT VOL			
	4438100730	JACK RCA 1P(B)			
	4438100920	JACK RCA 2P (B,B WOOFER)			
	4438100530	JACK RCA 3P(B)			
	4438100220	JACK RCA 4P(WW,RR)			
H551	4428806966	JUMPER HEADER 6P P2.5 H3.0			
	4448402966	JUMPER SHUNT 2P P2.5			
IC515 (RSX-972 ONLY)	2138322012	Masking CXP819P60Q-4			
IC400-401	2408218001	OPTO JACK RX-8A			



# Chassis Layout

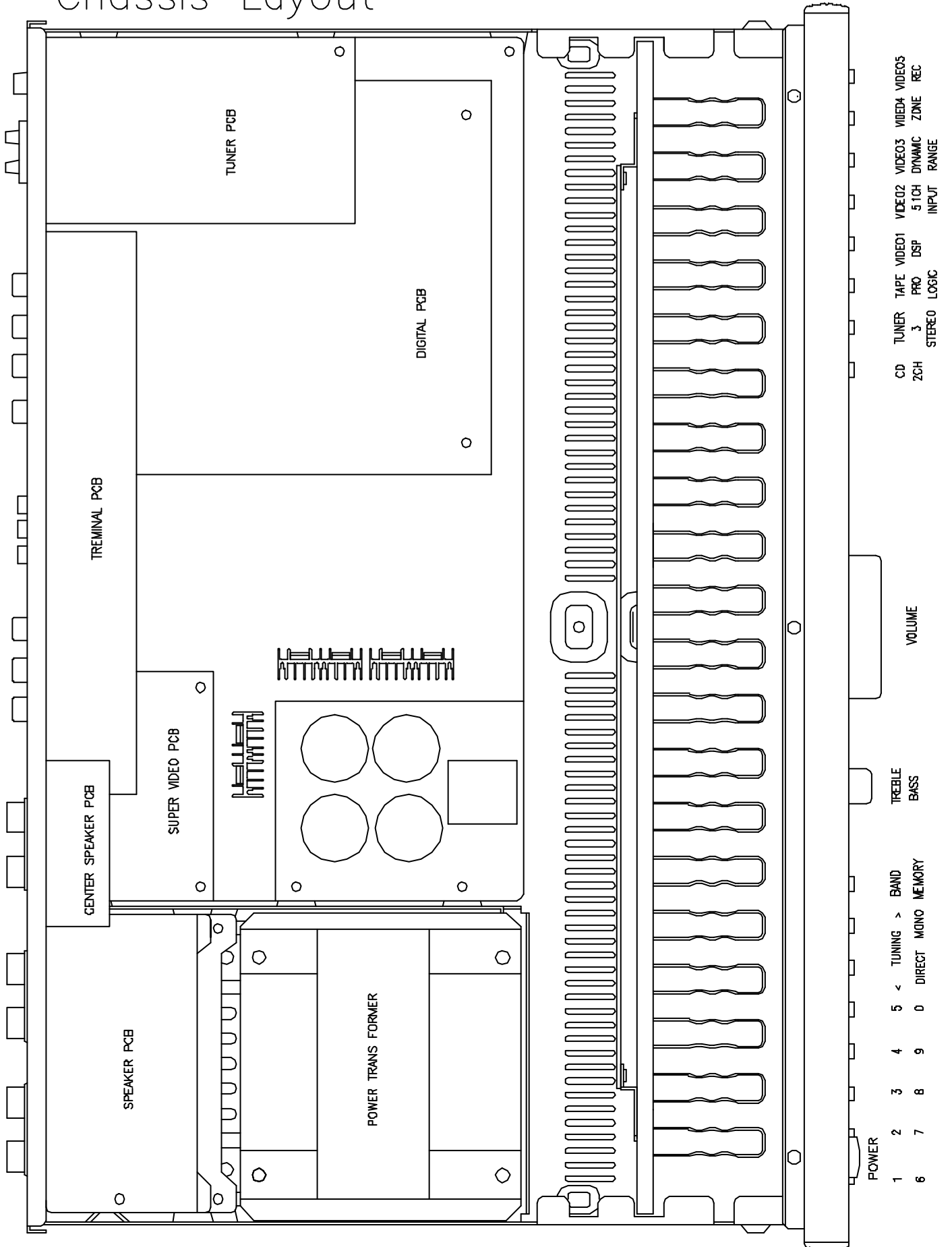

# Tuner Adjustment Method

## FM Section

### \* Necessary measurement equipment

RDS/STEREO Multiplexer, FM/AM Signal Generator, Audio Analyzer, Oscilloscope, Digital Volt Meter (DVM)

### (A) Center adjust

RDS/STEREO Multiplexer Setting

- MODE : **MONO** - Audio Frequency : **1KHz**

FM Signal Generator Setting

- Deviation : **75KHz** - Radio Frequency : **98.1MHz** - Output Level : **66dB**

RSX972 Setting

- FM Frequency : **97.9MHz** - FM MODE : **MONO**

1. Turn FM Signal Generator Modulation on
2. Connect DVM (+)(-) terminals to **Jumper J7 and J8** and measure the volt.
3. If measured voltage is not adjusted within  $\pm 10\text{mV}$ , Make this measured volt '**0**' by adjusting **T04** (FM-DET-A Coil).  
: **The adjustment should be within  $\pm 10\text{mV}$**
4. After this adjustment, measure **THD**(Total Harmonic Distortion) with Audio Signal Generator
5. Adjust THD to minimum point with **T05**(FM-DET-B Coil). : **THD should be within 0.5%**

### (B) Channel Separation adjust

RDS/STEREO Multiplexer Setting

- MODE : **STEREO ( ONLY L-CH Signal OUT )** - Audio Frequency : **1KHz**

FM Signal Generator Setting

- Deviation : **75KHz** - Radio Frequency : **98.1MHz** - Output Level : **66dB**

RSX972 Setting

- FM Frequency : **98.1MHz** - FM MODE : **STEREO**

1. Turn FM Signal Generator Modulation on after **modulating only L-CH (or only R-CH)** at STEREO Multiplexer.
2. Confirm if '**STEREO**' indicator is **turned 'ON'** on the display
3. Measure output level via Audio Signal Analyzer and make the level as standard.
4. Turn FM Signal Generator Modulation on after **modulating only R-CH (or only L-CH)** at STEREO Multiplexer.
5. Measure output level via Audio Signal Analyzer (measure per a dB)
6. If measured output level is not lower than -40dB, Adjust output level to minimum position with **VR03** ( CH-SEPA. ADJ.).  
: **lower than -40dB**

### (C) TUNED Level adjust

RDS/STEREO Multiplexer Setting

- MODE : **STEREO** - Audio Frequency : **1KHz**

FM Signal Generator Setting

- Deviation : **75KHz** - Radio Frequency : **98.1MHz** - Output Level : **26dB**

RSX972 Setting

- FM Frequency : **98.1MHz** - FM MODE : **STEREO**

1. Turn FM Signal Generator Modulation 'ON' (confirm if output level is **26dB**)
2. Change the output level of the Generator from 20dB to 30dB  
and Confirm if 'STEREO' & 'TUNED' indicator of the DISPLAY turns on at 26db( $\pm 5$  dB)
3. If these indicators do not turn on at higher than 26dB( $\pm 5$ dB) or do not turn off at lower than 26( $\pm 5$ dB) ,  
Adjust **VR02 ( FM-ADJ )** up to the moment where 'STEREO' & 'TUNED' indicator turns **OFF & ON** at 26dB.
4. Confirm if 'STEREO' & 'TUNED' turns OFF when decreasing the output level slowly from 26dB to 25dB, 24dB ~~~.  
(Repeat the above 3. if not OFF in lower than 24dB.)
5. Push RSX-972's TUNE UP or DOWN button "**long**" at Signal Generator Output Level 26dB and **start Auto search**.  
Confirm if search **stops** at FM Frequency 98.1MHz.  
(Examine both of High Freq. -> 98.1MHz search , Low Freq. -> 98.1MHz search)



# RSX972 Conversion

< TUNER B'D VERSION OPTION >

< POWER B'D VERSION OPTION >

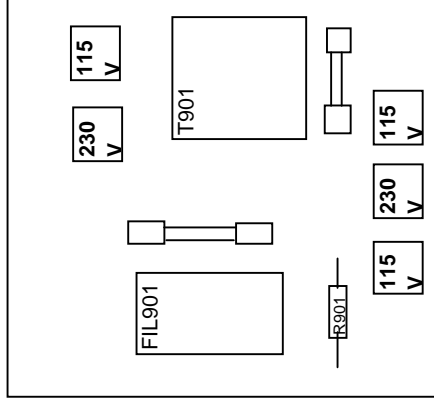
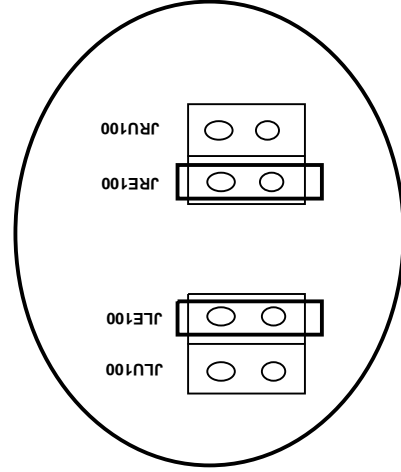
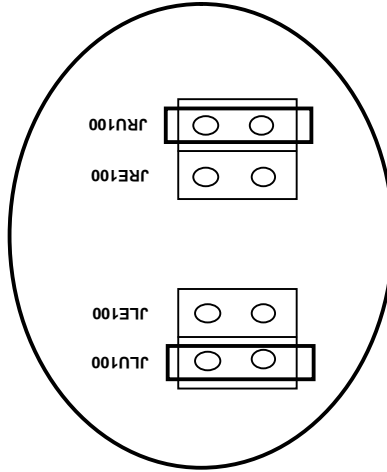
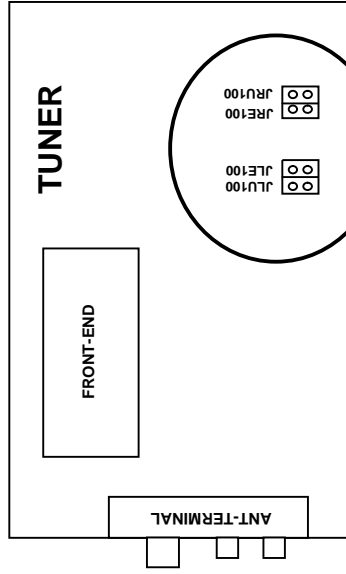
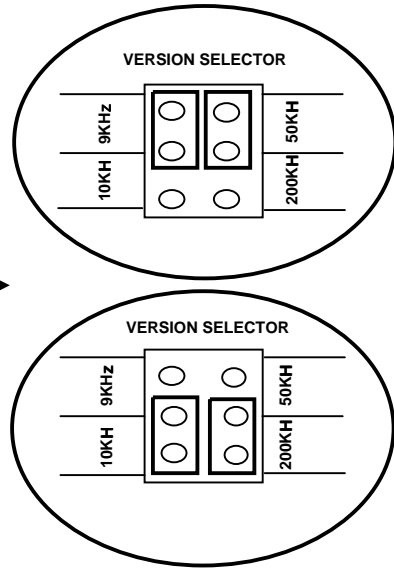
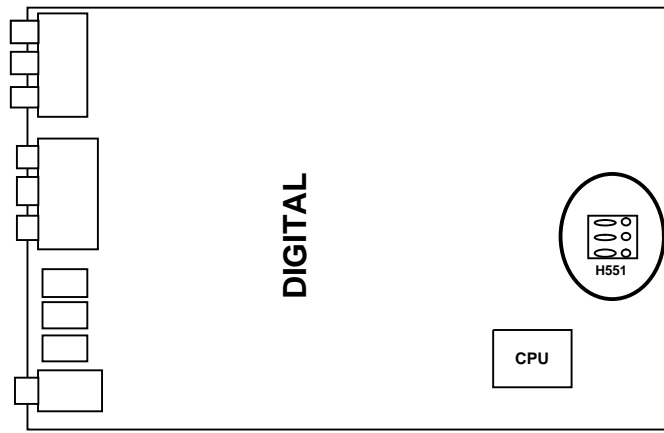

## FOR 01 VERSION (USA)

- INSERT FOLLOWING PARTS
- 115V JUMPER 3POINT(435502042147)
- F901 FUSE (7A/250V)
- F902 FUSE (315mA/250V)

## FOR 24 VERSION (EUROPE)

- INSERT FOLLOWING PARTS
- 230V JUMPER 2POINT (435502042147)
- F901 FUSE (T4A/250V)
- F902 FUSE (T250mA/250V)

# Case Outlines

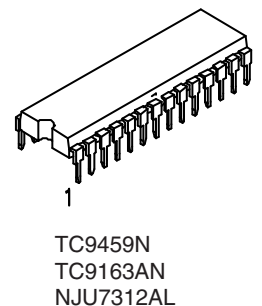
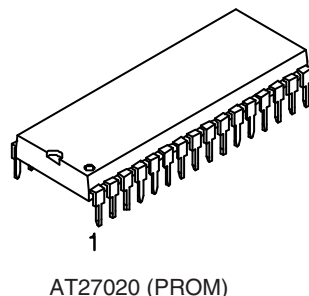
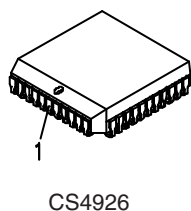
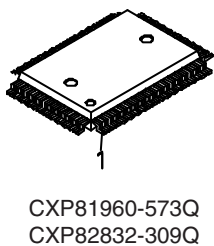
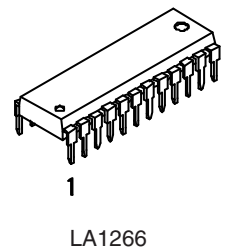
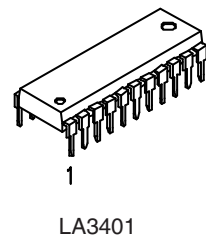
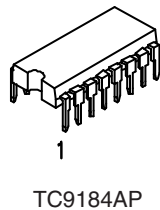
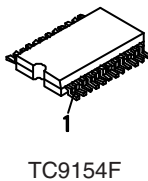
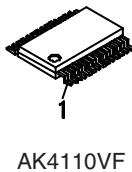
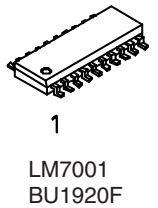
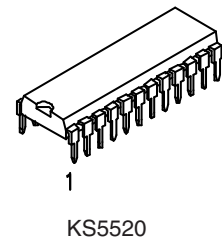
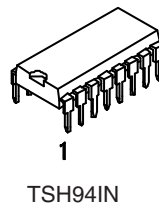
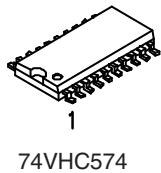
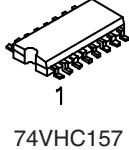
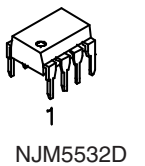
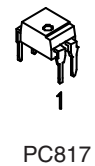
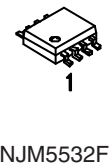
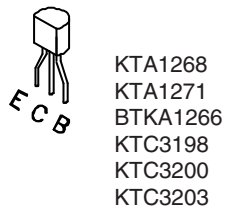
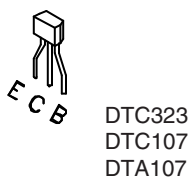
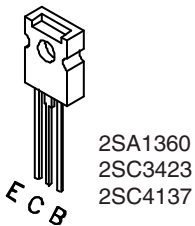
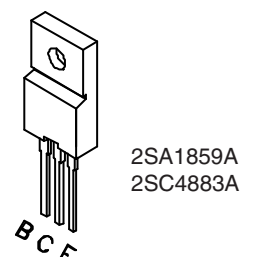
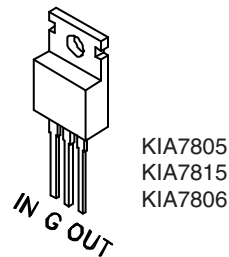
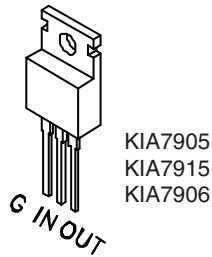
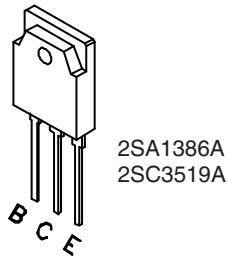
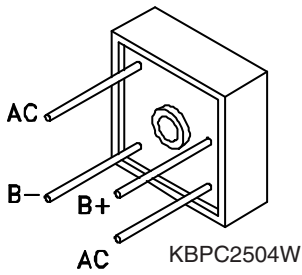

Meno



# PCB Assembly

4002000200

Amplifier Circuit Locations for RSX972

FRONT L

SURROUND L

CENTER

SURROUND R

FRONT R

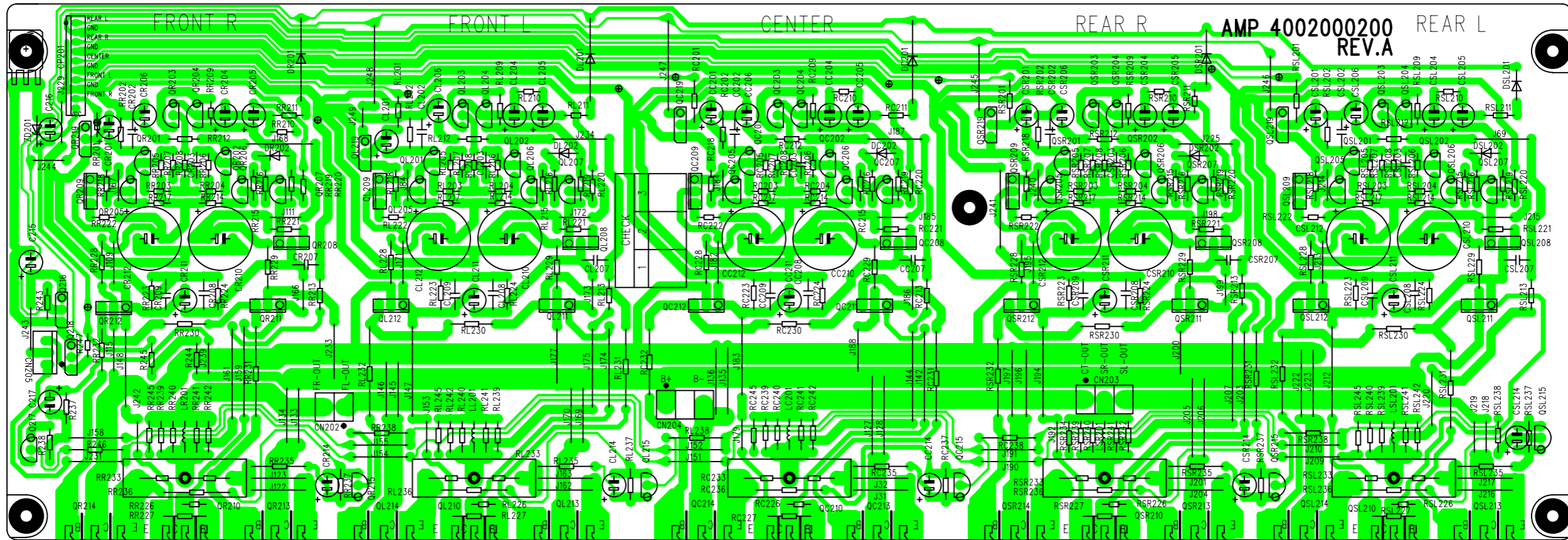

4002002700

4002002710

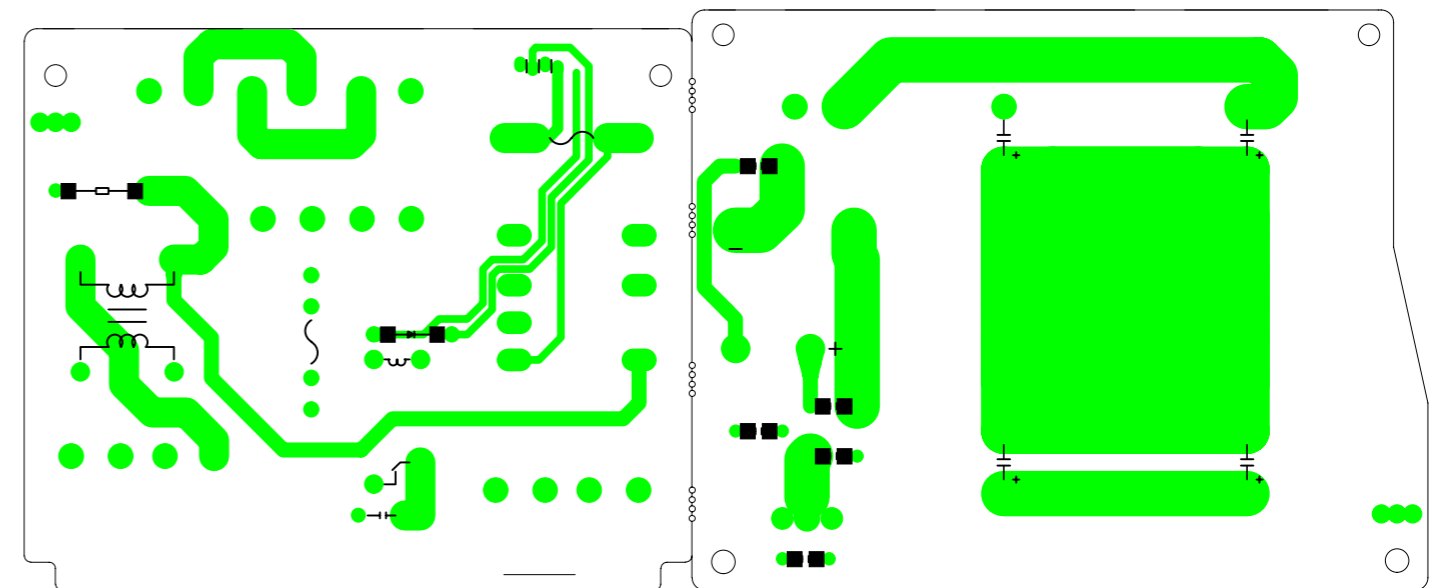
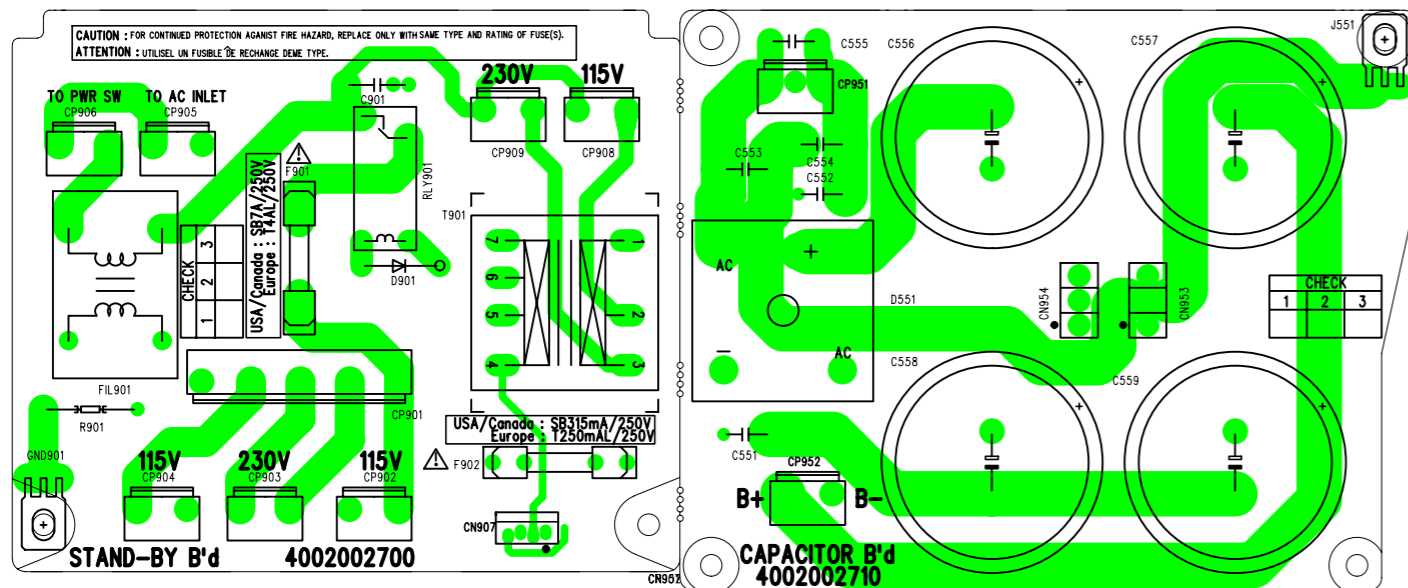

TOP VIEW

BOTTOM VIEW

# PCB Assembly

## 4002002800

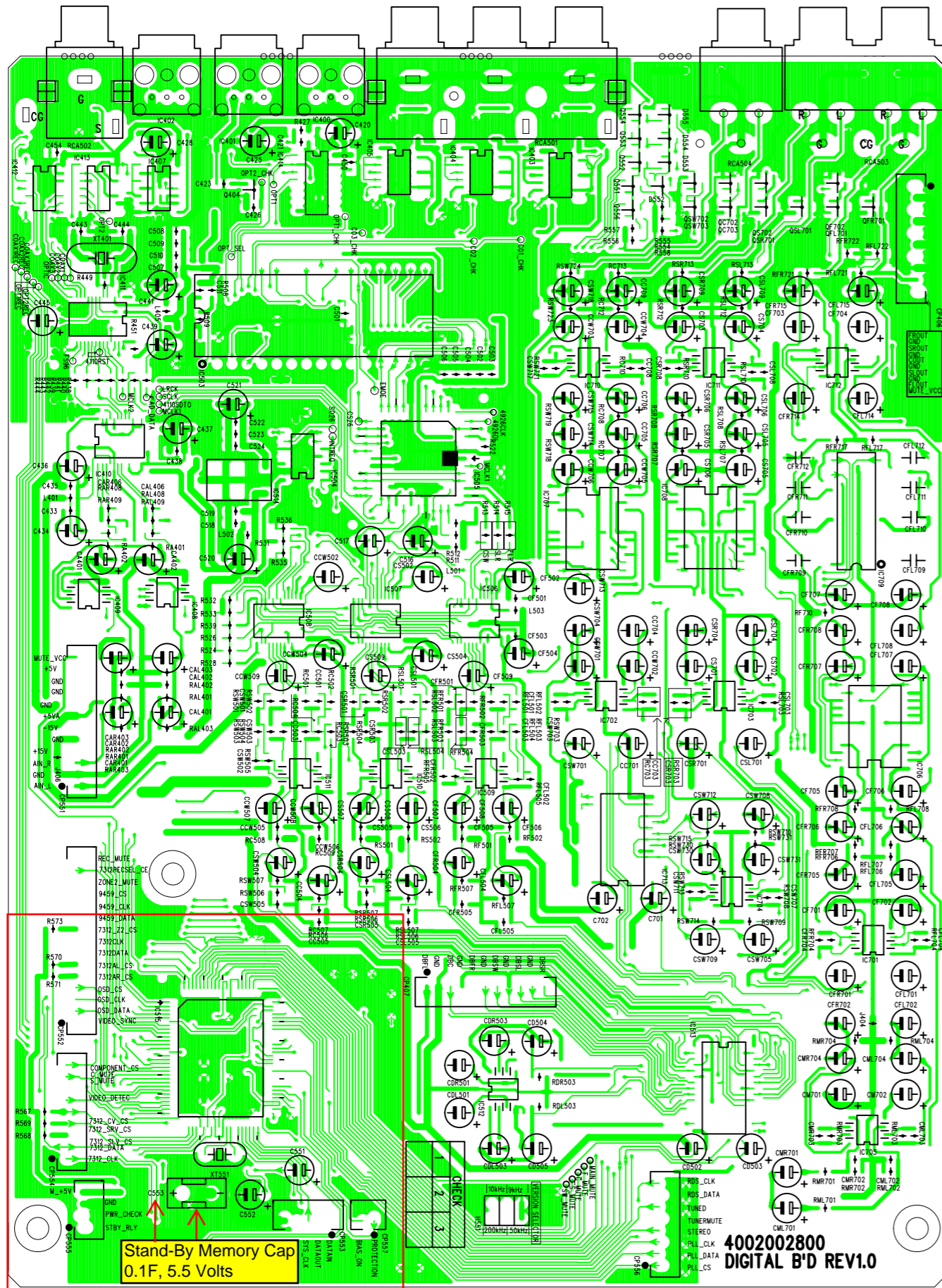

TOP SIDE

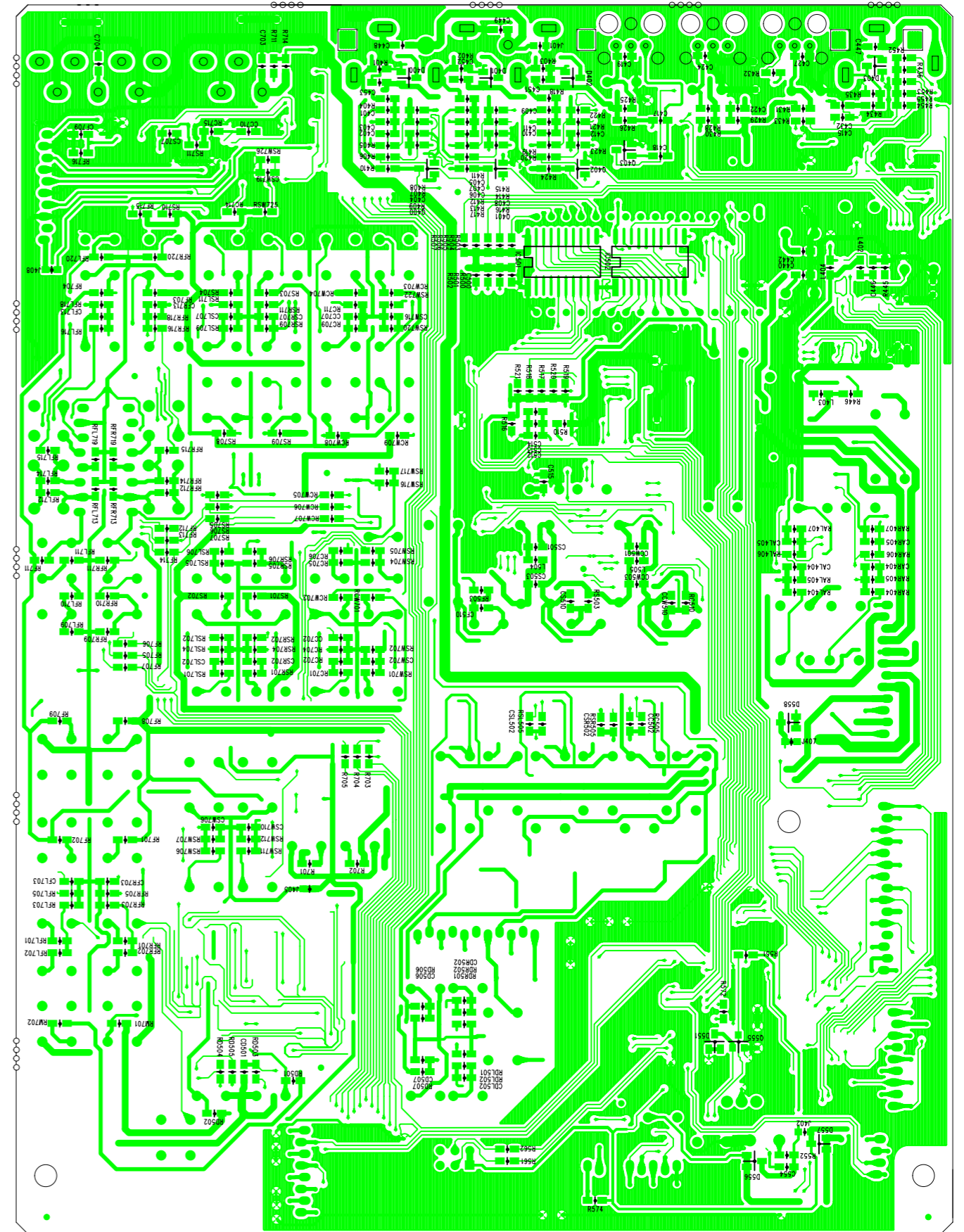

BOTTOM SIDE



# PCB Assembly

## 4002002500

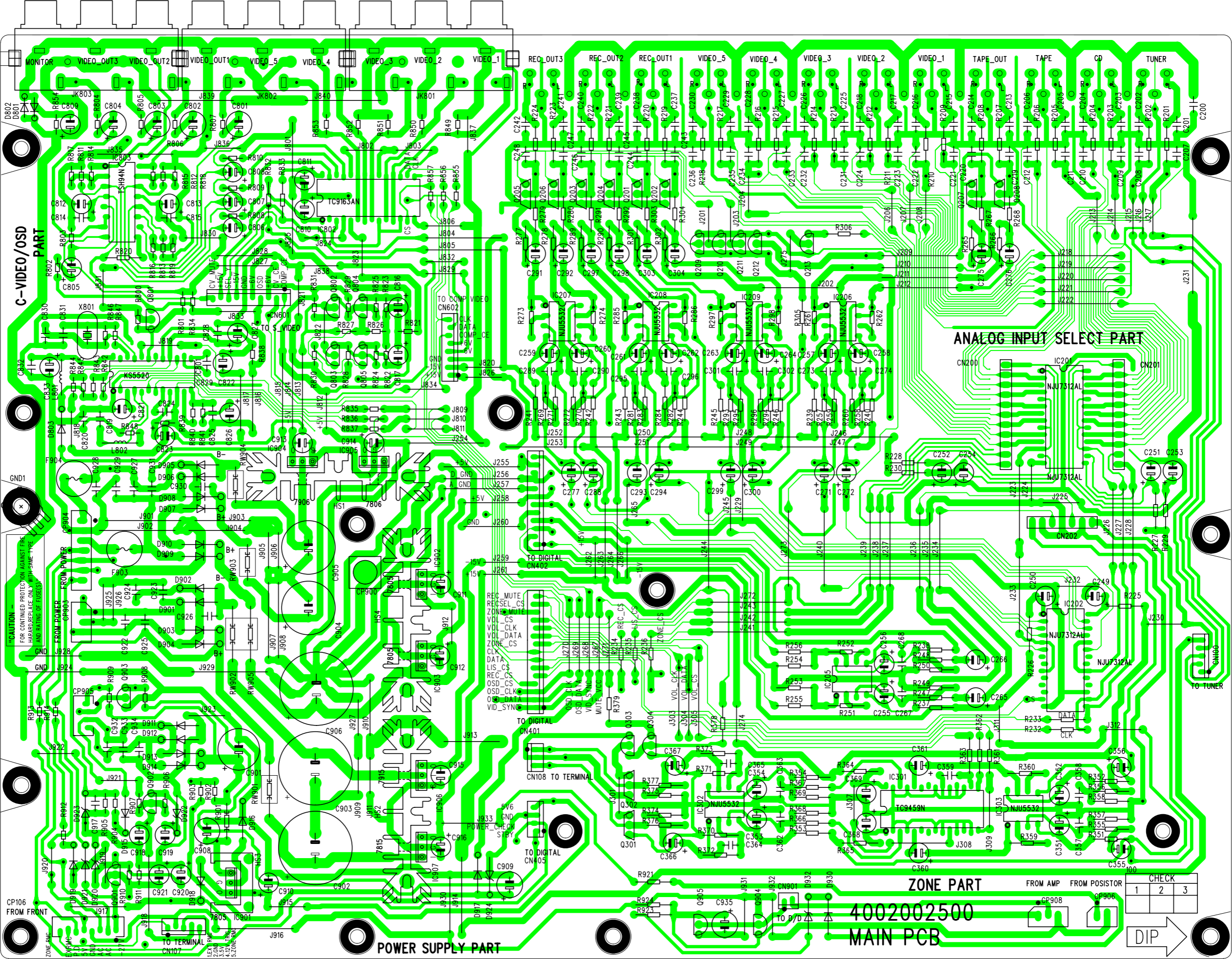

4002002500  
MAIN PCB

CHECK		
1	2	3

DIP

# PCB Assembly

4002002430

4002002440

4002002450

4002002460

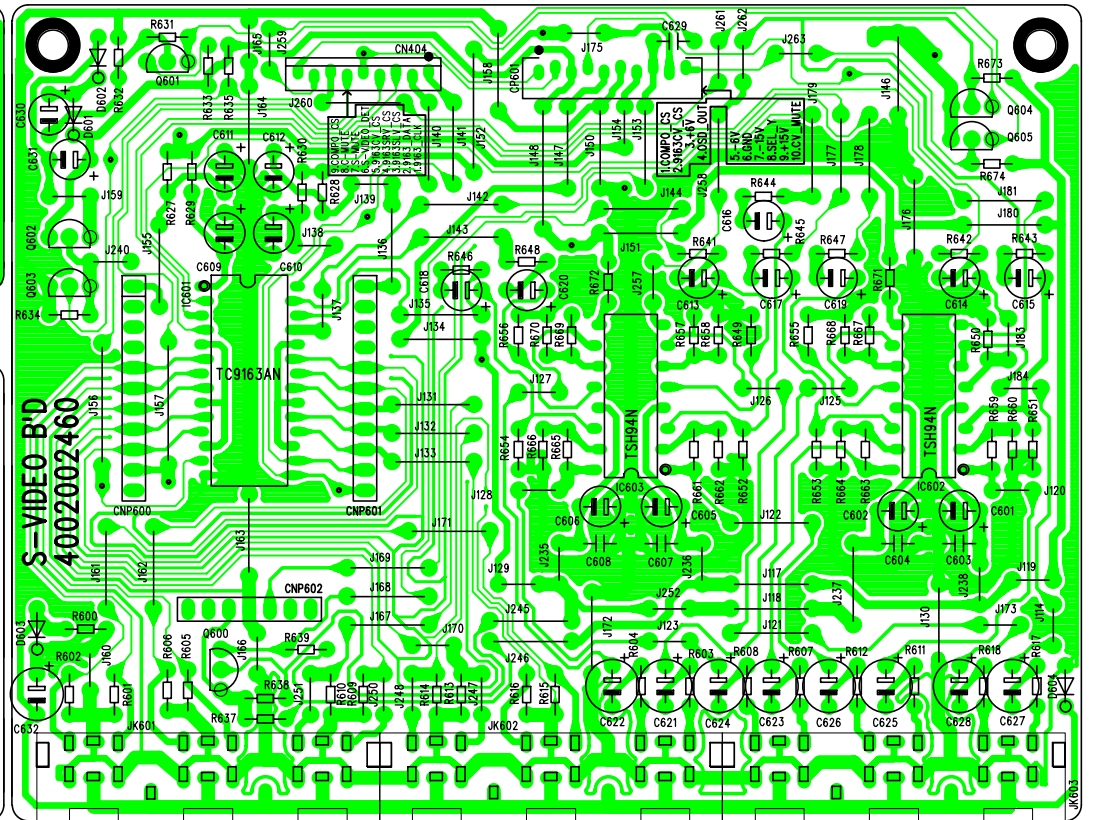
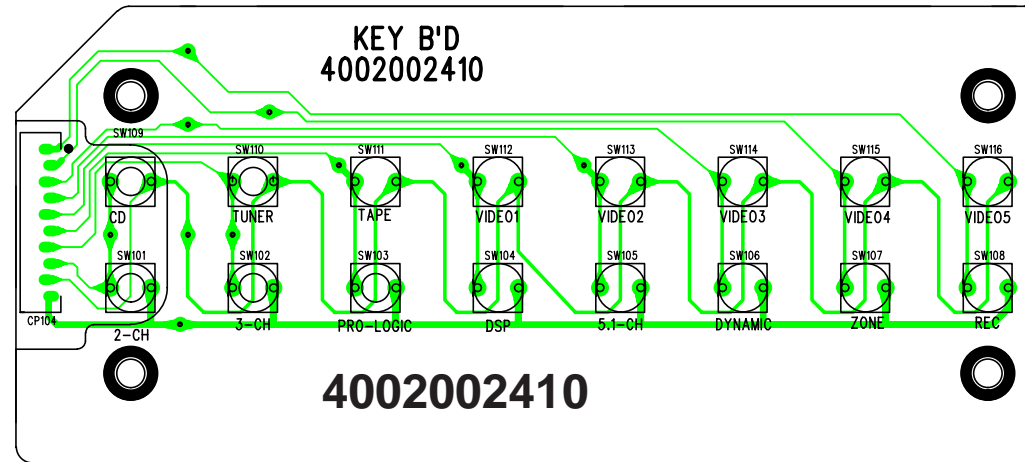
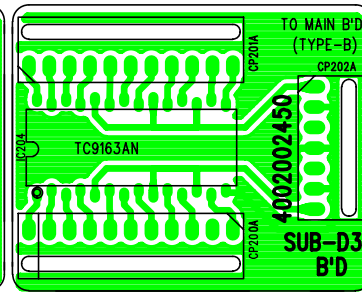
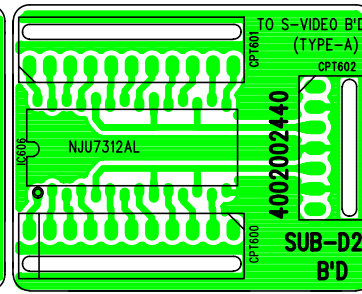
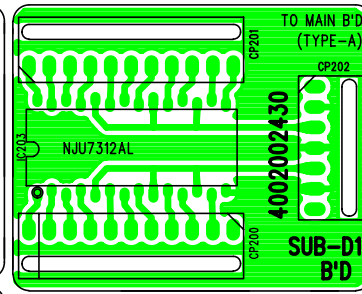
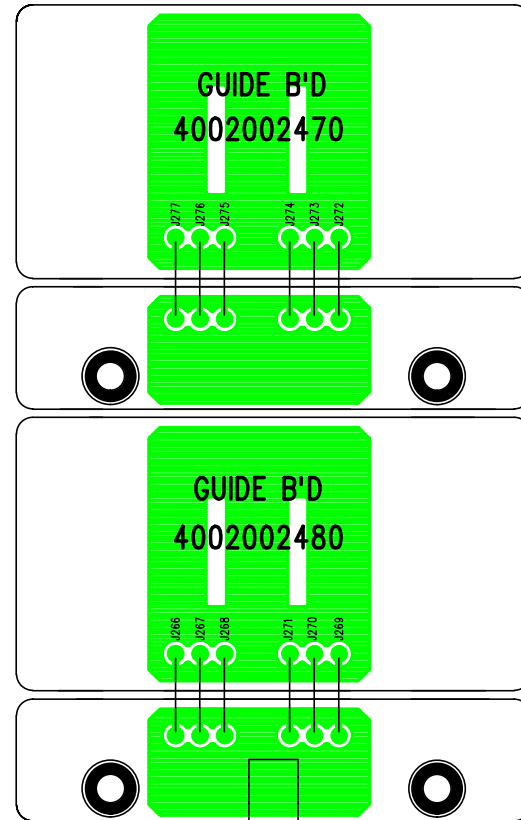

4002002420

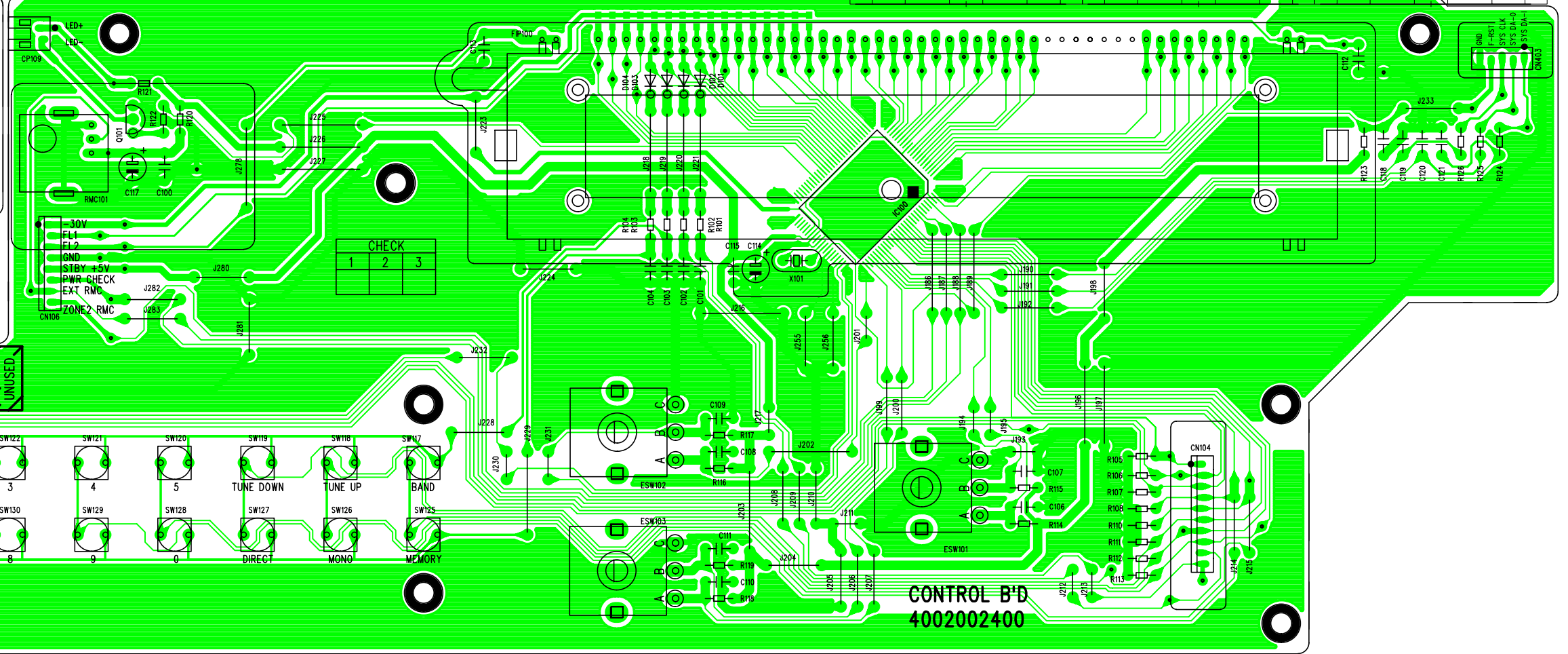
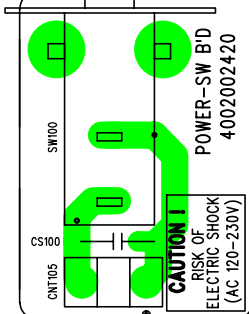

4002002400





# Block Diagram

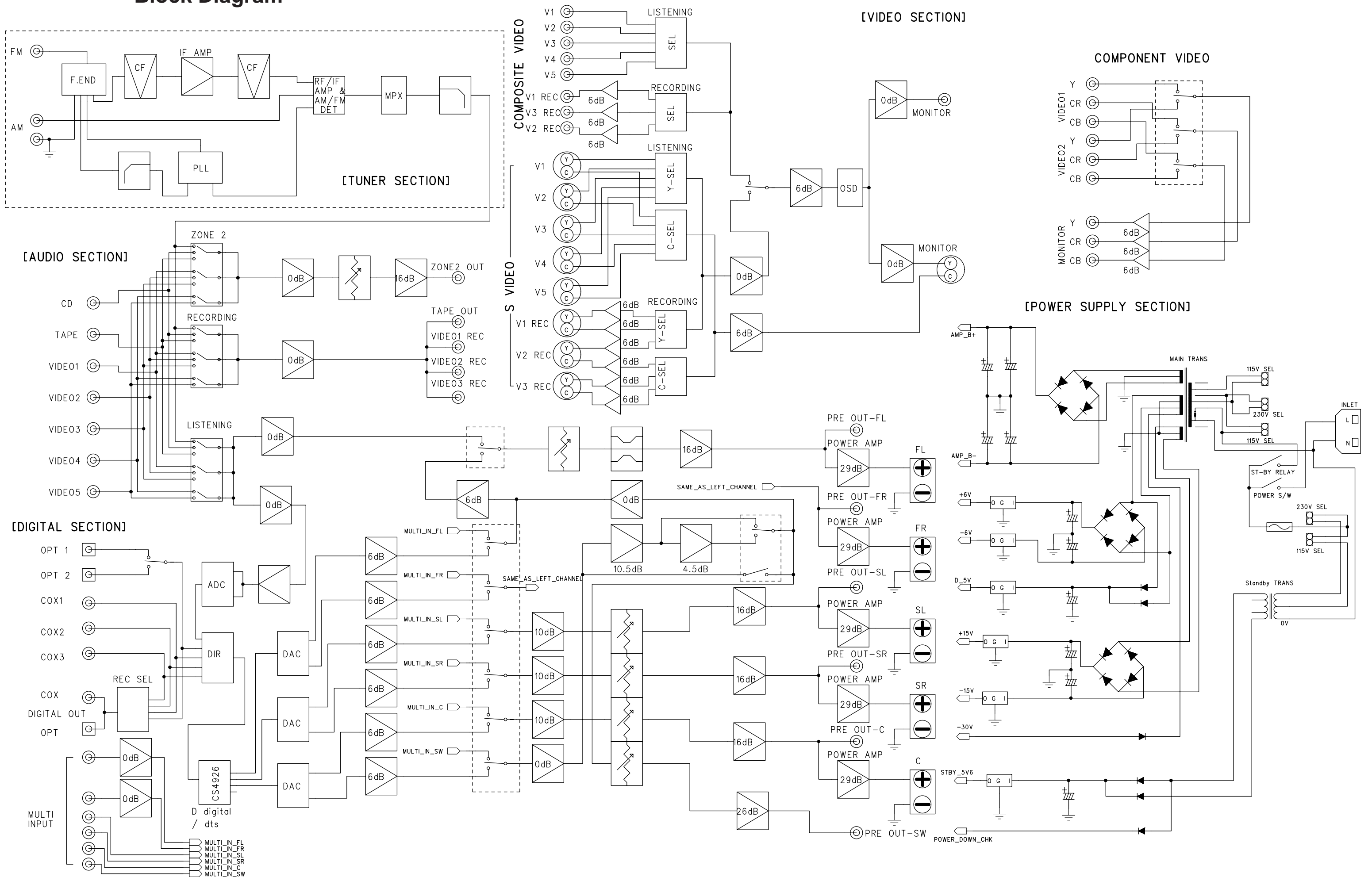



# Schematic Diagram

## 4002000200 Power Amplifier Board

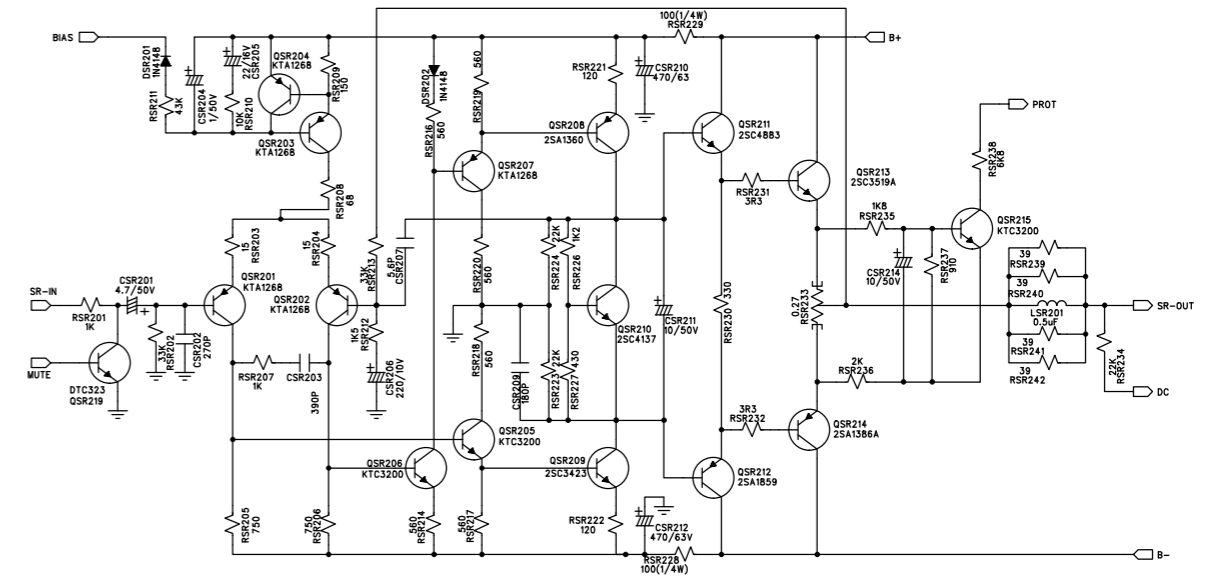
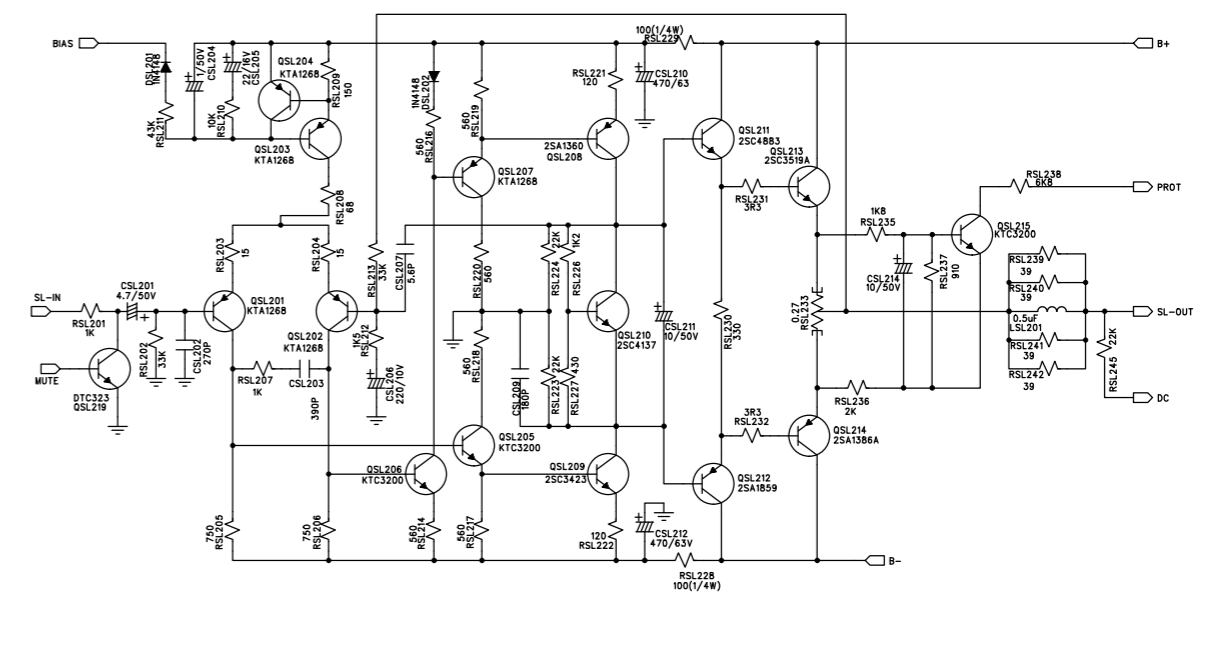
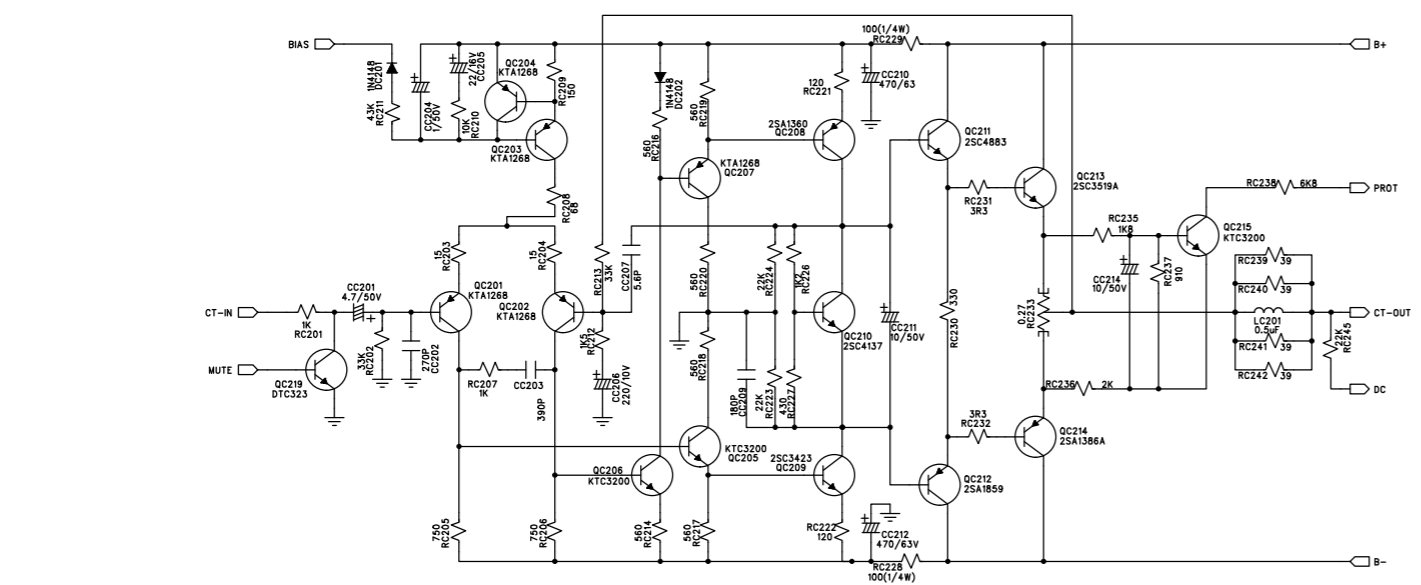
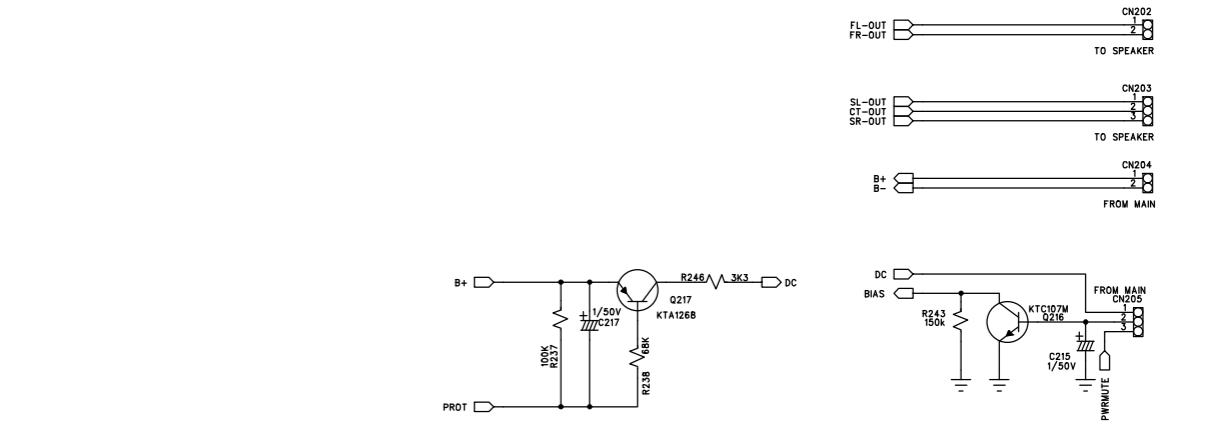
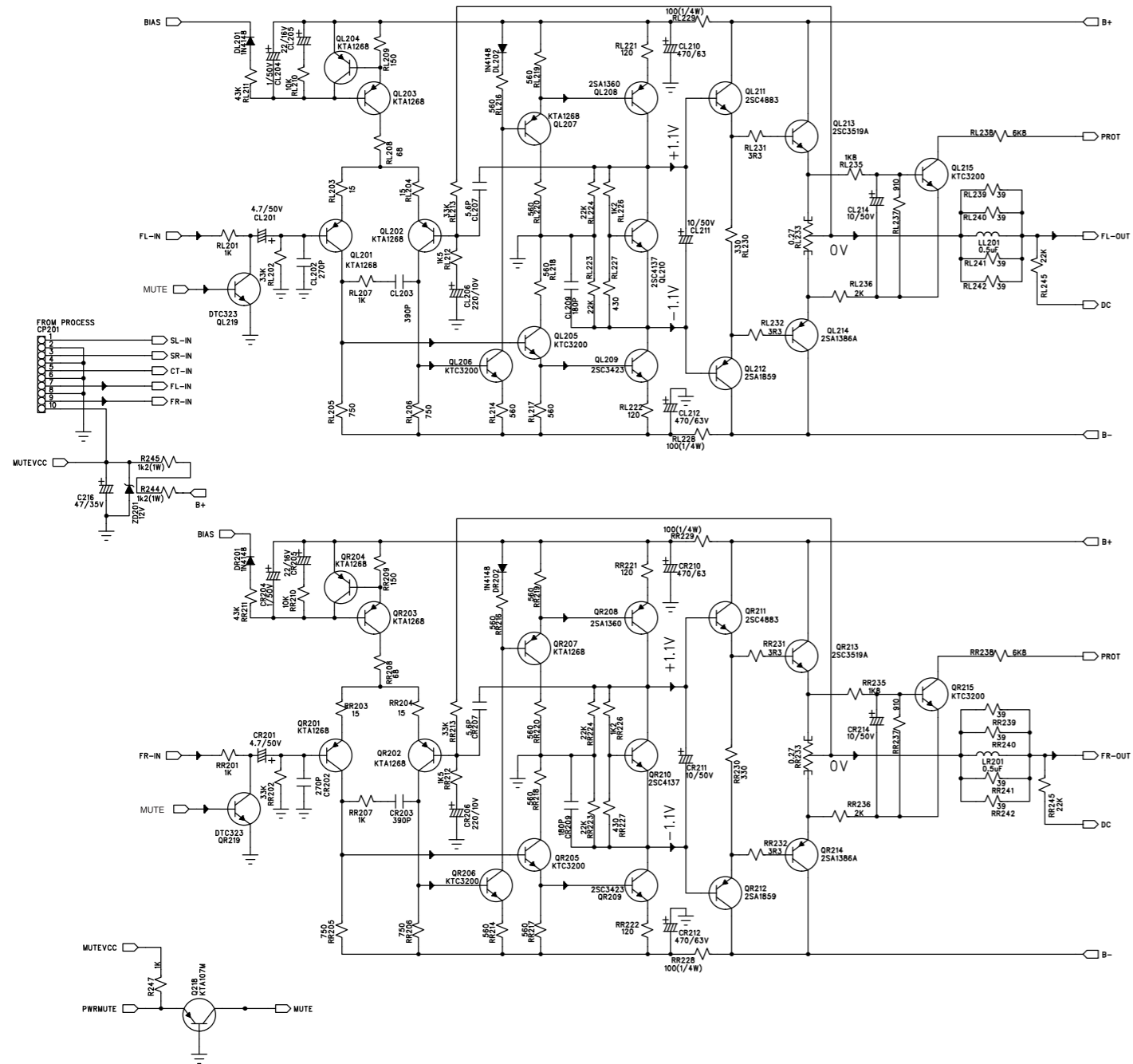

# Schematic Diagram

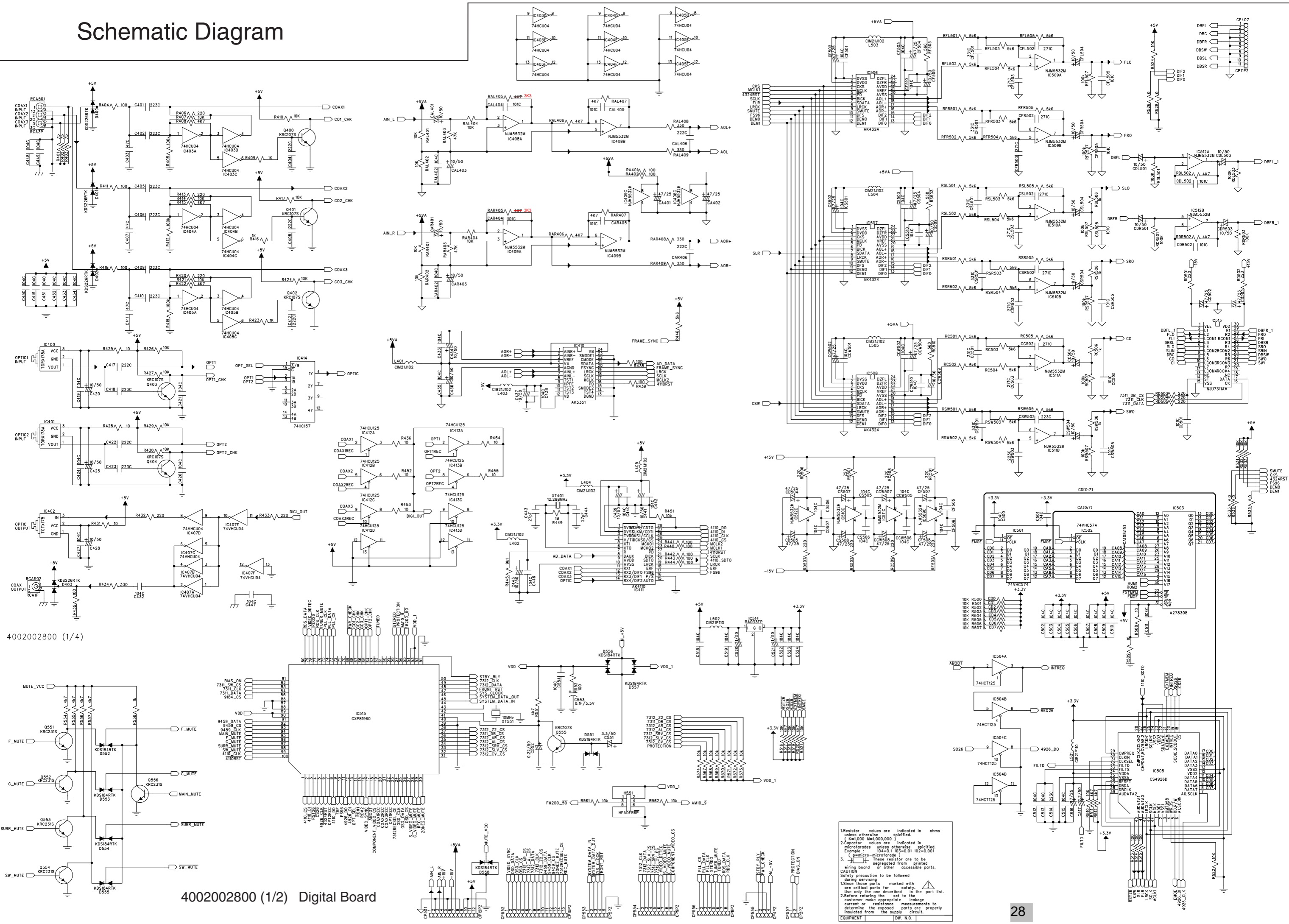

4002002800 (1/4)

4002002800 (1/2) Digital Board

1. Resistor values are indicated in ohms unless otherwise specified.  
 2. Capacitor values are indicated in microfarads unless otherwise specified.  
 3. (p)micro-microfarade)  
 These resistors are to be segregated from printed wiring board or other accessible parts.  
 CAUTION  
 Safety precaution to be followed during servicing:  
 1. Since these parts marked with are critical parts for safety. Use only the one described in the part list.  
 2. Before returning the set to the customer make appropriate leakage current or resistance measurements to determine the exposed parts are properly insulated from the supply circuit.  
 EQUIPMENT DW. N.O.

# SCHMATIC DIAGRAM (Revised)

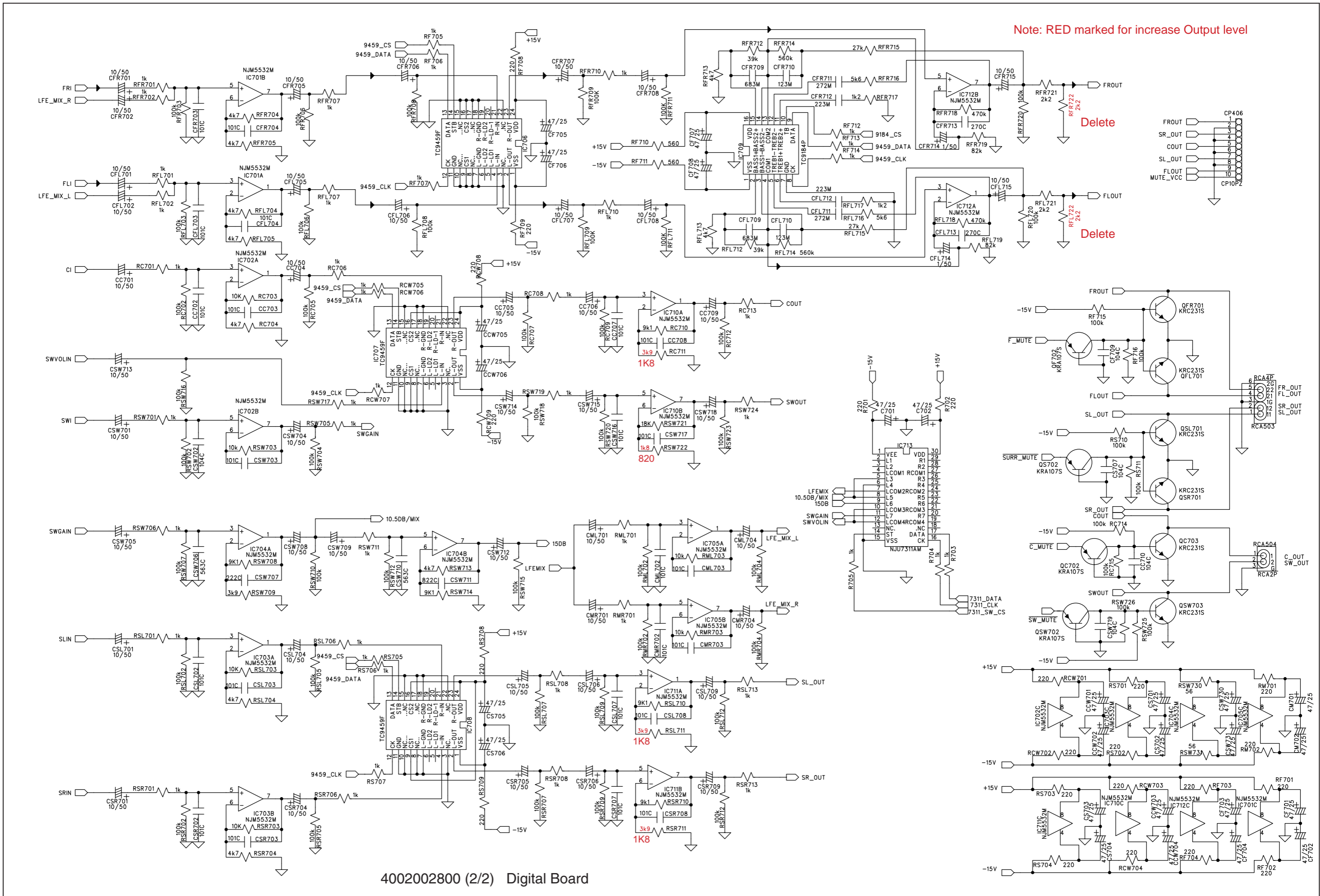

Note: RED marked for increase Output level

Delete

Delete

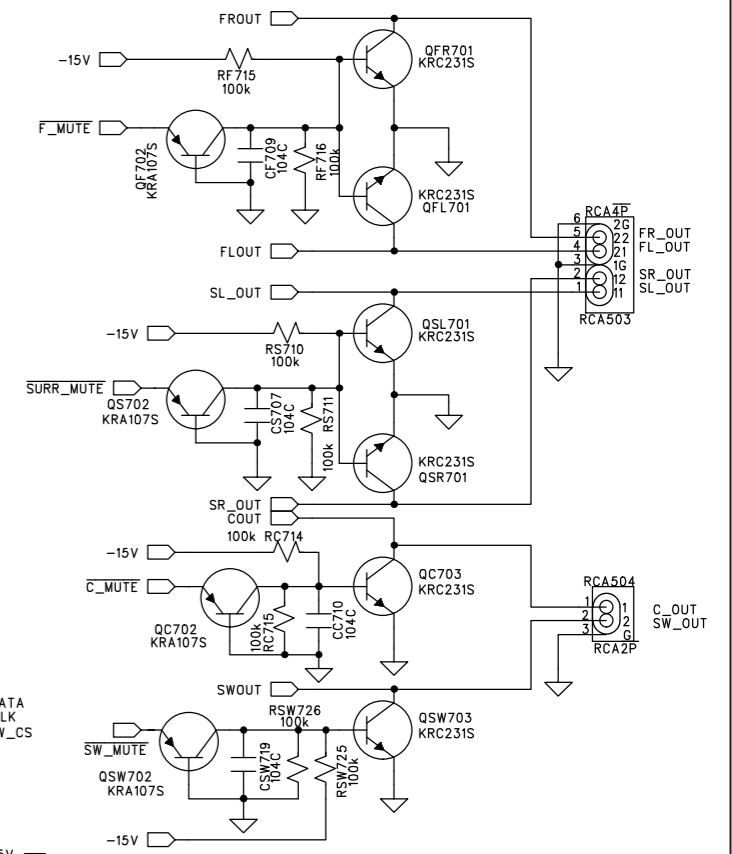
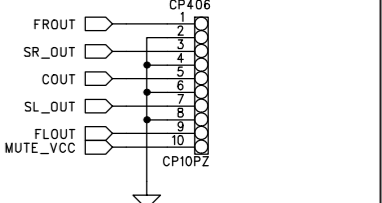

4002002800 (2/2) Digital Board



# SCHMATIC DIAGRAM

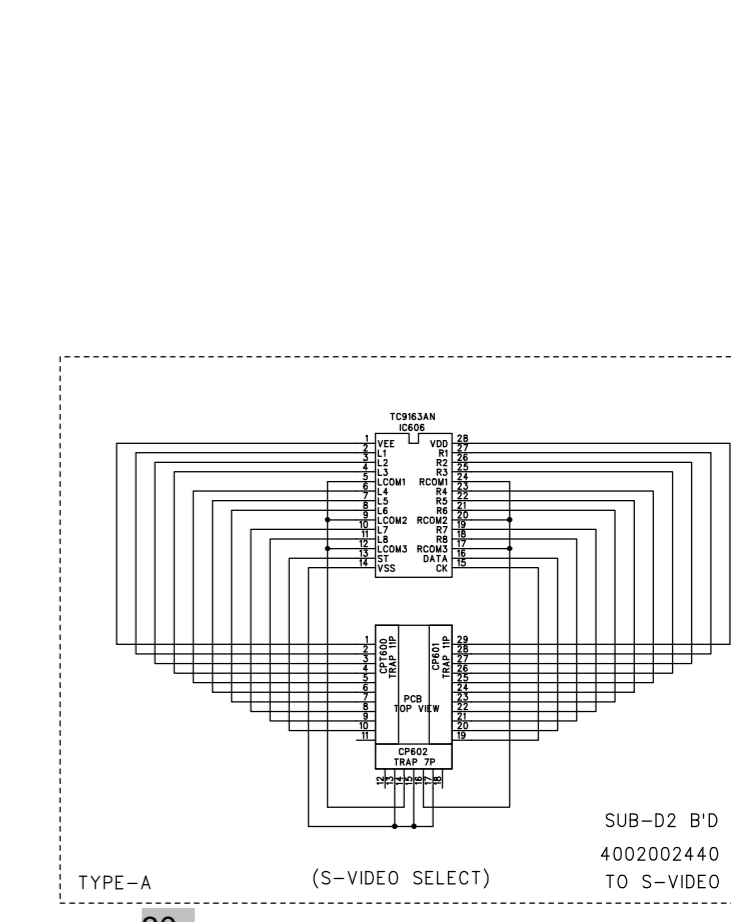
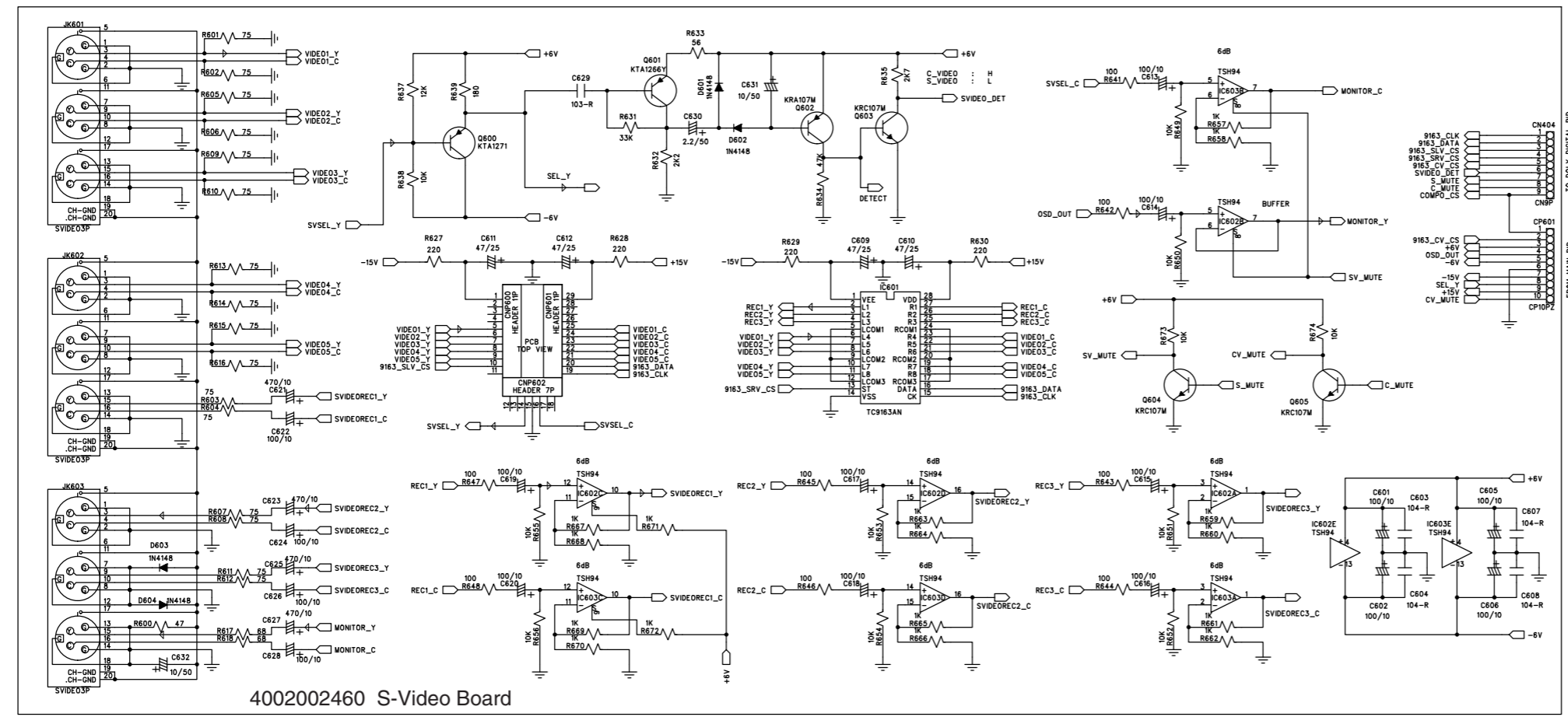
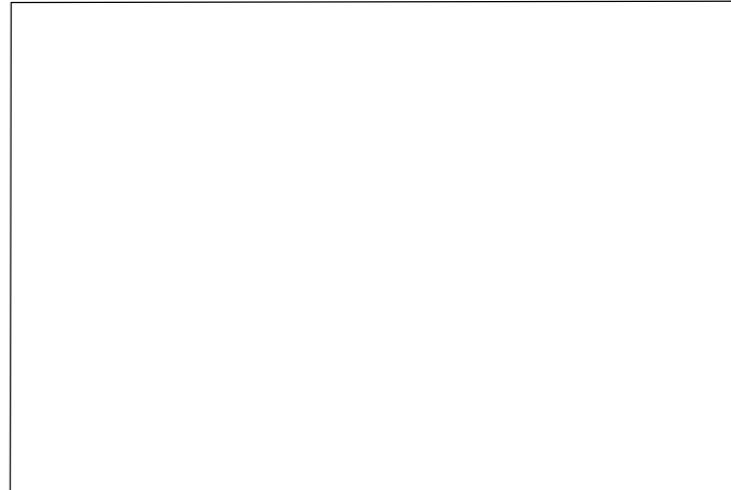
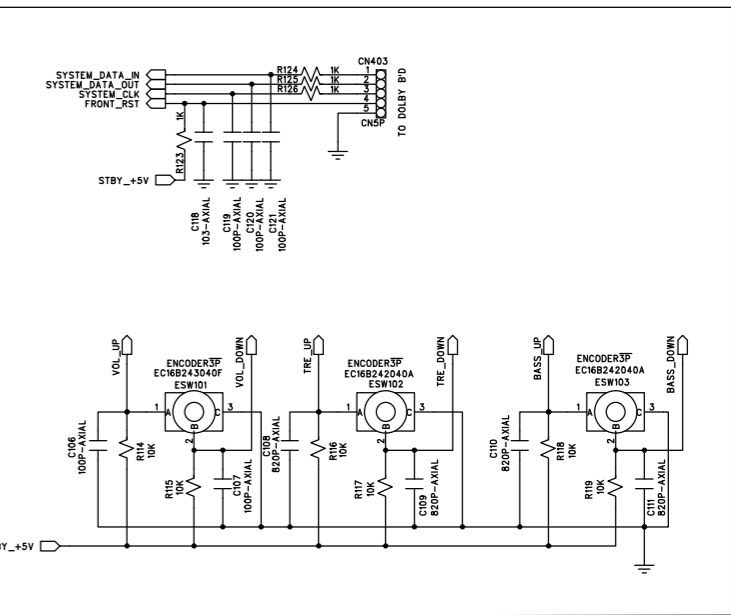
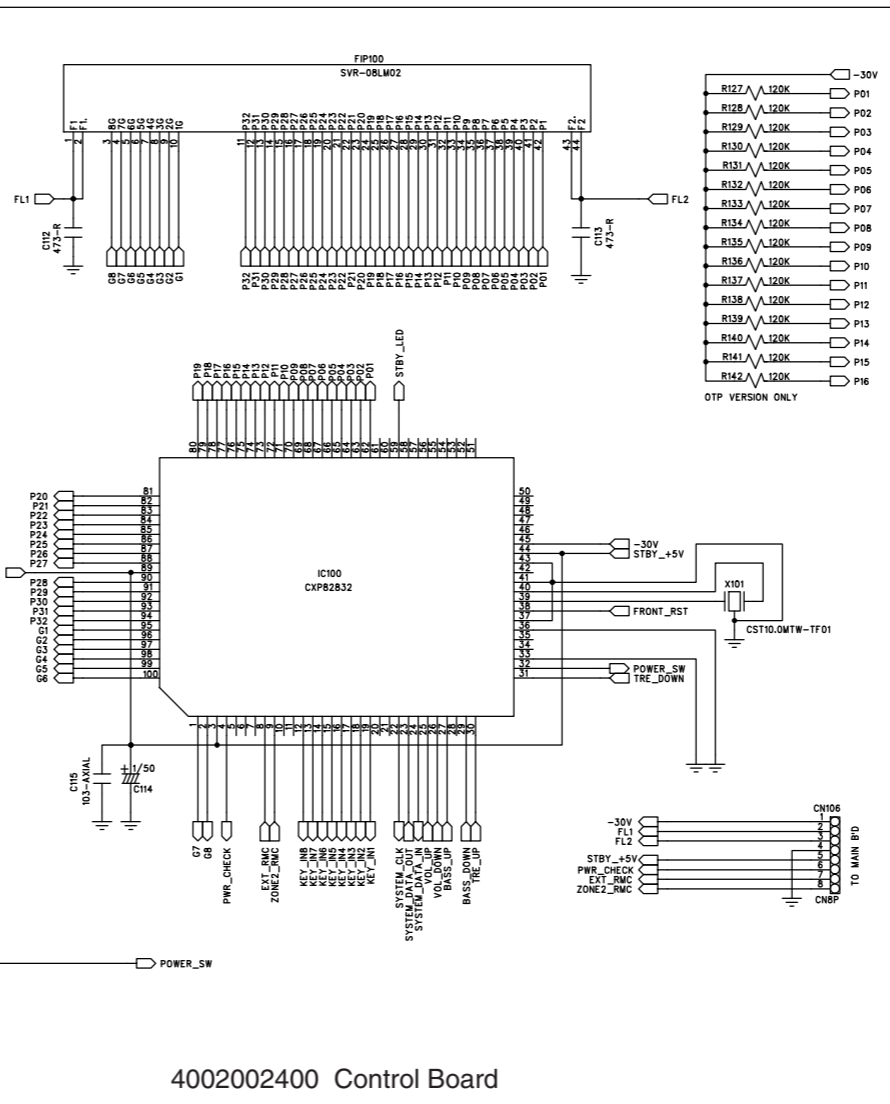
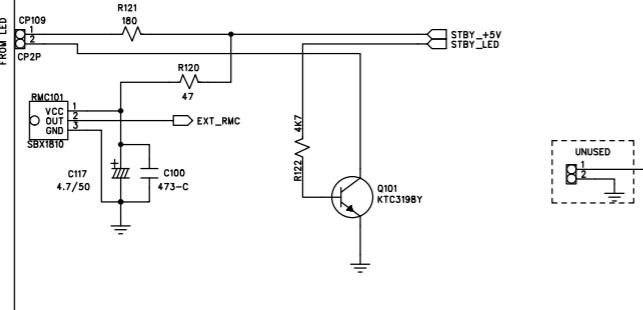
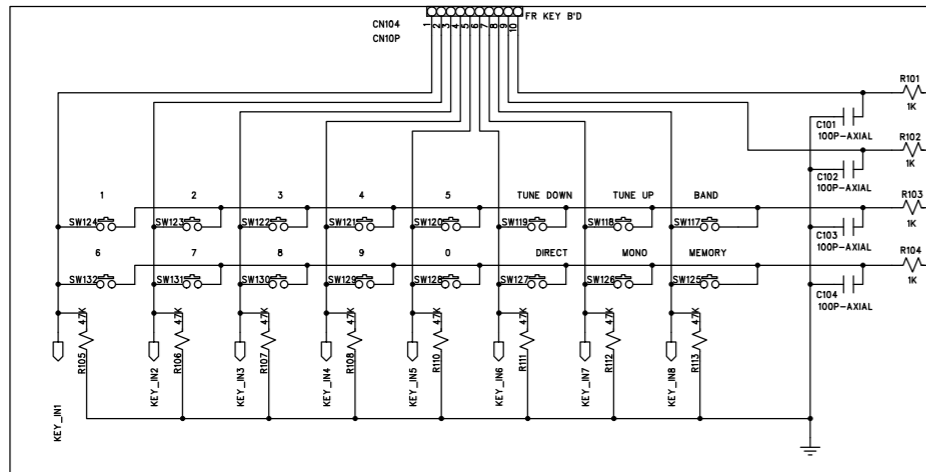
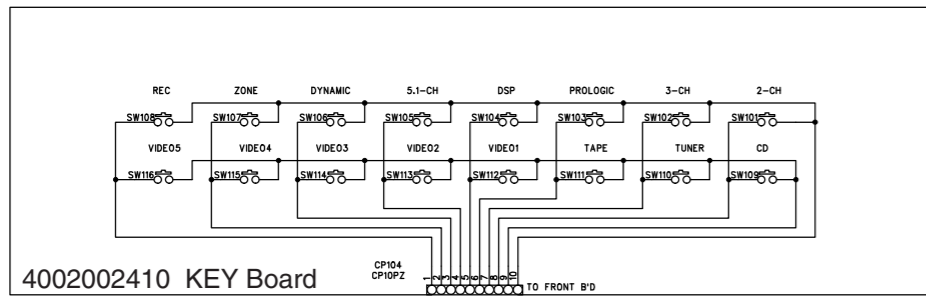

# SCHEMATIC DIAGRAM

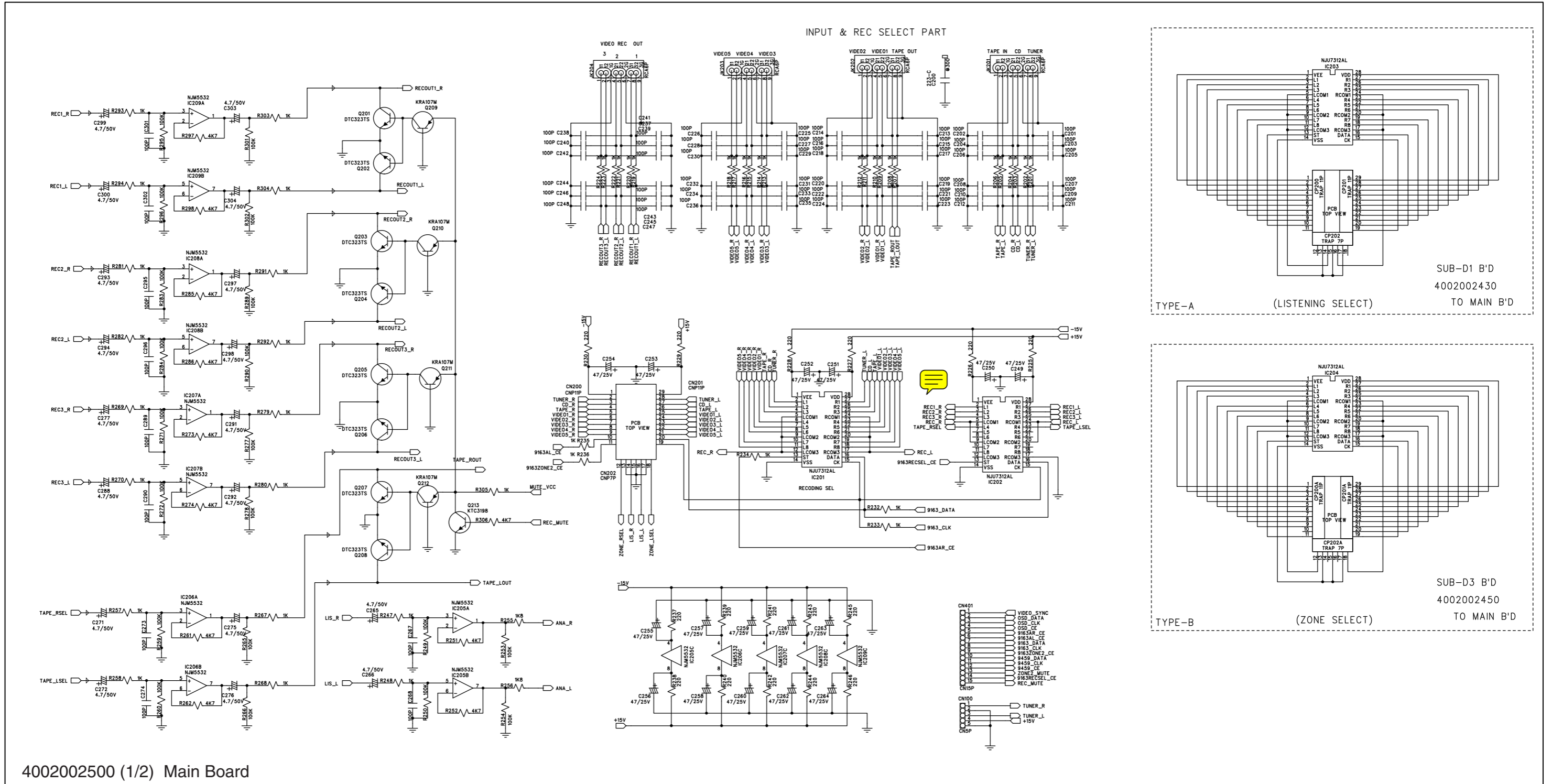

4002002500 (1/2) Main Board



# SCHEMATIC DIAGRAM

