



Technical Manual

AM/FM STEREO TUNER RT-02

Table of Contents

- Specification.....1
- Parts List2~6
- Adjustment.....7~8
- Case Outline9~10
- PCB Assembly11~12
- Wiring Diagram13
- Schematic Diagram14~16

Specifications

FM Tuner

- Usable Sensitivity:**
14.2 dBf
- 50dB Quieting Sensitivity:**
20.2 dBf (mono)
45.3 dBf (stereo)
- Signal to Noise Ratio (at 65 dBf):**
73 dBf (mono)
70 dBf (stereo)
- Harmonic Distortion (at 65dBf):**
0.2% (mono)
0.3% (stereo)
- Frequency Response:**
10 Hz-15 kHz, ±3 dB
- Capture Ratio:**
2.0 dB
- Alternate Channel Selectivity:**
47 dB (±400 kHz)
- Spurious Response Ratio:**
90 dB
- Image Rejection Ratio:**
80 dB
- IF Rejection Ratio:**
80 dB
- AM Suppression Ratio:**
55 dB
- Stereo Separation (100Hz/1 kHz/10 kHz):**
40 dB/45 dB/35 dB
- Output level:**
1V
- Antenna Input:**
75 ohms unbalanced

AM Tuner

- Usable Sensitivity:**
500 µV/m
- Selectivity:**
25 dB
- Harmonic Distortion:**
0.5%
- Image Rejection Ratio:**
45 dB
- Signal to Noise Ratio:**
40 dB
- Output level:**
500 mV
- Antenna Input:**
Loop Antenna

General

- Power Consumption:**
10 watts
- Power Requirements (AC):**
115 volts, 60 Hz (USA version)
230 volts, 50 Hz (European version)
- Dimensions (W x H x D):**
435 x 73 x 319 mm
17 1/8 " x 2 7/8 " x 10 9/16"
- Panel Height**
60 mm / 2 3/8"
- Weight:**
3.9 Kg/8.6 lb.

THE ROTEL CO., LTD

SHINSEN-BLD. 4F 10-10 SHINSEN-CHO, SHIBUYA-KU,
TOKYO 150-0045, JAPAN

| |
|--------------------------|
| Serial. NO. Beginning |
|--------------------------|

Appearance

RT-02

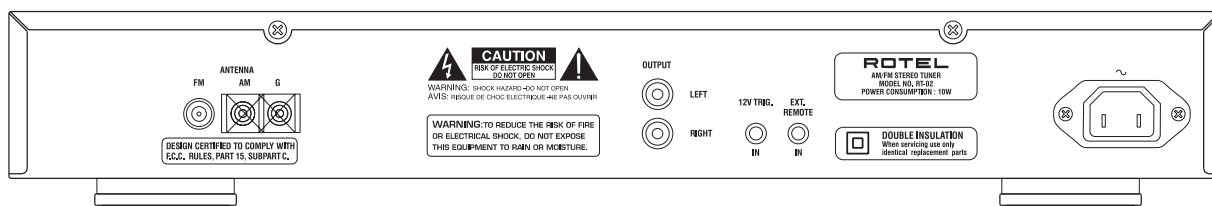
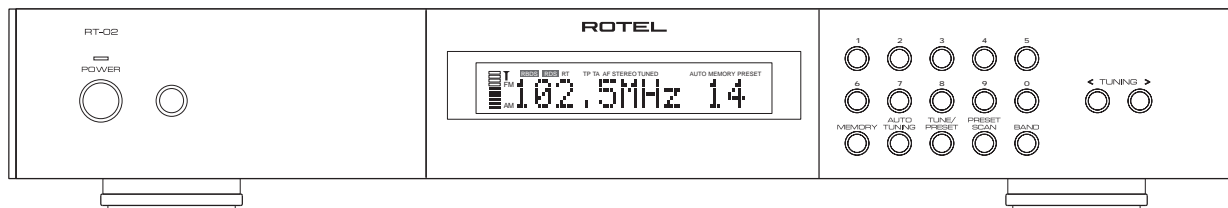

| SYMBOL | PARTS NO. | DESCRIPTION |
|----------------------------------|------------------|---------------------------------|
| 016 X-1320A01-04 PCB ASSY | | |
| | 501X-1320-B | PCB ASSY |
| JK301 | 066 4TR-2166#4 | 2P PIN JACK AU (WHT. RED) |
| JK302 | 065 YKB21-5103A | 3.5Φ MINI JACK |
| JK303 | 065 YKB21-5111A | 3.5Φ MINI JACK |
| R301,315 | 053 CR14-101J-A | CARBON RESISTOR 1/4W 100 |
| R201,210 | 053 CR14-103J-A | CARBON RESISTOR 1/4W 10K |
| R302 | 053 CR14-123J-A | CARBON RESISTOR 1/4W 12K |
| R207,314,316 | 053 CR14-102J-A | CARBON RESISTOR 1/4W 1K |
| R204 | 053 CR14-222J-A | CARBON RESISTOR 1/4W 2.2K |
| D208 | 053 CR14-272J-A | CARBON RESISTOR 1/4W 2.7K |
| R203 | 053 CR14-201J-A | CARBON RESISTOR 1/4W 200 |
| R318 | 053 CR14-221J-A | CARBON RESISTOR 1/4W 220 |
| R209 | 053 CR14-223J-A | CARBON RESISTOR 1/4W 22K |
| R211 | 053 CR14-332J-A | CARBON RESISTOR 1/4W 3.3K |
| RM103 | 053 CR14-472J-A | CARBON RESISTOR 1/4W 4.7K |
| RM101 | 053 CR14-470J-A | CARBON RESISTOR 1/4W 47 |
| RM102 | 053 CR14-471J-A | CARBON RESISTOR 1/4W 470 |
| R205 | 053 CR14-473J-A | CARBON RESISTOR 1/4W 47K |
| R303 | 053 CR14-512J-A | CARBON RESISTOR 1/4W 5.1K |
| C201,202,213 | 043 TC50V223 | CERAMIC CAPACITOR 0.022uF |
| C209,CM102 | 043 TC50V473 | CERAMIC CAPACITOR 0.047uF |
| C204,205 | 043 TC500V103 | CERAMIC CAPACITOR 500V0.01uF |
| D201,204,205 | 034 T1N4003-TB | DIODE 1N4003-E |
| D209,302 | 034 T1N4148-86 | DIODE 1N4148TAP-50 |
| C212 | 041 UTES1C101-FB | ELECTROLYTIC CAPACITOR 16V100uF |
| C211 | 041 UTES1C221-FB | ELECTROLYTIC CAPACITOR 16V220uF |
| C210 | 041 UTES1E470-FB | ELECTROLYTIC CAPACITOR 25V47uF |
| C301,302 | 041 TEEUFC1E470B | ELECTROLYTIC CAPACITOR 25V47uF |
| C206 | 041 UTES1V332 | ELECTROLYTIC CAPACITOR 35V330uF |
| CM101 | 041 UTES1H100-FB | ELECTROLYTIC CAPACITOR 50V10uF |
| C208 | 041 UTES1H010-FB | ELECTROLYTIC CAPACITOR 50V1uF |
| C207 | 041 UTES1H4R7-FB | ELECTROLYTIC CAPACITOR 50V4.7uF |
| C307,308 | 041 TEEUFC1H4R7B | ELECTROLYTIC CAPACITOR 50V4.7uF |
| C203 | 041 UTES1H470-FB | ELECTROLYTIC CAPACITOR 50V47uF |
| FL101 | 035 SVR12MM18 | FL TUBE |
| F201,202 | 036 5ST500 | FUSE 250VT500mA |
| IC301 | 031 OPA2604AP | IC (OPE DUAL) |
| IC302,303 | 031 PC817B | IC (PHOTO COUPLER) |
| IC201 | 031 NJM317F | IC (REGULATOR) |
| RMC101 | 031 SBX3010-52B | IC (REMOTE EYE) |
| R308,309 | 054 TMFR4100K | METAL RESISTOR 1/4W 100K |
| R310-313 | 054 TMFR4001K | METAL RESISTOR 1/4W 1K |
| R304,305 | 054 TMFR404K7 | METAL RESISTOR 1/4W 4K7 |
| R306,307 | 054 TMFR406K8 | METAL RESISTOR 1/4W 6K8 |
| R401 | 053 CR1W2M2 | MOF RESISTOR 1W 2.2M (USA ONLY) |
| R202 | 054 1WS330JF | MOF RESISTOR 1W 330 |
| R206,208 | 054 2WS270JF | MOF RESISTOR 2W 270 |
| SW401 | 061 C-4176A08 | POWER SWITCH PS3-22SPA-P7AZ |
| TS401 | 022 T-1065N01 | POWER TRANSFORMER |
| CS401 | 044 DE1307E472M | SPARK KILLER 4700pF |
| C305,306 | 044 S50V1000PG | STYROL CAPACITOR 50V1000pF |
| C309-312 | 044 S50V100PJ | STYROL CAPACITOR 50V100pF |
| Q201,203 | 032 KRC107M | TRANSISTOR |
| Q202,204,QM101 | 032 KTC3198Y-AT | TRANSISTOR |
| Q301 | 032 KRA107M | TRANSISTOR |
| Q302,303 | 032 TDT323TS | TRANSISTOR |
| D207 | 034 TRD12JST1 | ZENER DIODE 12V (AB2) |
| D203 | 034 TRD30JST1 | ZENER DIODE 30V (AB2) |
| D206 | 034 TRD5.6JST1 | ZENER DIODE 5.6V (AB2) |

Parts List 2/4

| SYMBOL | PARTS NO. | DESCRIPTION |
|-----------------------------------|-------------------|-----------------------------------|
| D202 | 034 TRD6.2JST1 | ZENER DIODE 6.2V (AB2) |
| 016 E-1319A00 PCB ASSY | | |
| | 501E-1319-B | PCB ASSY |
| C116,117 | 047 ECJ2VF1H473Z | CERAMIC CAPACITOR CHIP 50V0.047uF |
| C110-112 | 047 ECJ2VF1H104Z | CERAMIC CAPACITOR CHIP 50V0.1uF |
| C115 | 047 ECJ2VG1H102J | CERAMIC CAPACITOR CHIP 50V1000pF |
| C101-105,114 | 047 ECJ2VG1H101J | CERAMIC CAPACITOR CHIP 50V100pF |
| C109 | 047 ECJ2VG1H821J | CERAMIC CAPACITOR CHIP 50V820pF |
| D101-105,108 | 034 T1N4148-86 | DIODE 1N4148TAP-50 |
| C108 | 041 TUTES1H010-TF | ELECTROLYTIC CAPACITOR 50V1uF |
| C108 | 041 UTES1H220-FB | ELECTROLYTIC CAPACITOR 50V22uF |
| IC101 | 031 CXP82832-316Q | IC (CPU) |
| (IC101) | 031 CXP82832-347Q | IC (CPU) |
| IC102 | 031 AT24C16PC-2.7 | IC (EEPROM) |
| R101-105,115 | 055 ERJ6GEYJ122V | RESISTOR CHIP 1.2K |
| R113,116-120,123,125 | 055 ERJ6GEYJ103V | RESISTOR CHIP 10K |
| R131-165 | 055 ERJ6GEYJ124V | RESISTOR CHIP 120K |
| R124 | 055 ERJ6GEYJ102V | RESISTOR CHIP 1K |
| R121,122 | 055 ERJ6GEYJ2R2V | RESISTOR CHIP 2.2 |
| R114,126 | 055 ERJ6GEYJ472V | RESISTOR CHIP 4.7K |
| R108-111 | 055 ERJ6GEYJ473V | RESISTOR CHIP 47K |
| SW101-117 | 061 C-4679A05 | TACT SWITCH THV10920 |
| Q101 | 032 KTC3198Y-AT | TRANSISTOR |
| 016 E-4002002301 PCB ASSY | | |
| | 501E-4002002300-D | PCB ASSY |
| FE01 | 092 FTA4-460H | FRONT-END |
| C38 | 043 TC50V101 | CERAMIC CAPACITOR 100pF |
| C16 | 043 TC50VCH150 | CERAMIC CAPACITOR 15pF |
| C09,58,C59 | 043 TC50VCH270 | CERAMIC CAPACITOR 27pF |
| C08 | 043 TC50VCH330 | CERAMIC CAPACITOR 33pF |
| C37 | 043 TC50V820 | CERAMIC CAPACITOR 82pF |
| C04,07,23 | 047 ECJ2VB1H103K | CERAMIC CAPACITOR CHIP 50V0.01uF |
| C01,06,12,13,17,18,21,22,29,34,40 | 047 ECJ2VB1H223K | CERAMIC CAPACITOR CHIP 50V0.022uF |
| C02,24,25,42 | 047 ECJ2VF1H473Z | CERAMIC CAPACITOR CHIP 50V0.047uF |
| C57 | 047 ECJ2VF1H104Z | CERAMIC CAPACITOR CHIP 50V0.1uF |
| C10 | 047 ECJ2VG1H101J | CERAMIC CAPACITOR CHIP 50V100pF |
| CLU52,CRU52 | 047 ECJ2VG1H100D | CERAMIC CAPACITOR CHIP 50V10pF |
| CL50,CR50 | 047 ECJ2VG1H121J | CERAMIC CAPACITOR CHIP 50V120pF |
| C54 | 047 ECJ2VG1H271J | CERAMIC CAPACITOR CHIP 50V270pF |
| C36 | 047 ECJ2VG1H331J | CERAMIC CAPACITOR CHIP 50V330pF |
| C43 | 047 ECJ2VG1H681J | CERAMIC CAPACITOR CHIP 50V680pF |
| CL52,CR52 | 047 ECJ2VG1H680J | CERAMIC CAPACITOR CHIP 50V68pF |
| CLU50,CRU50 | 047 ECJ2VG1H820J | CERAMIC CAPACITOR CHIP 50V82pF |
| T01 | 021 RLV152A00 | COIL AM ANT |
| T03 | 021 RLV154A00 | COIL AM IFT |
| T02 | 021 RLV155A00 | COIL AM OSC |
| T04 | 021 RLV157A00 | COIL FM DET-A |
| T05 | 021 RLV158A00 | COIL FM DET-B |
| TL06,TR06 | 021 RLV156A00 | COIL MPX LPF |
| D02 | 034 T1N4148-86 | DIODE 1N4148TAP-50 |
| C14,35,44 | 041 TUTES1C101-TF | ELECTROLYTIC CAPACITOR 16V100uF |
| C05,11 | 041 TUTES1C470-TF | ELECTROLYTIC CAPACITOR 16V47uF |
| C46 | 041 TUTES1HR22-TF | ELECTROLYTIC CAPACITOR 50V0.22uF |
| C20,39,49,53,55,56,CL51,CR51 | 041 TUTES1H100-TF | ELECTROLYTIC CAPACITOR 50V10uF |
| C33,45,47 | 041 TUTES1H010-TF | ELECTROLYTIC CAPACITOR 50V1uF |
| C03,27 | 041 TUTES1H3R3-TF | ELECTROLYTIC CAPACITOR 50V3.3uF |
| C26,28,41 | 041 TUTES1H4R7-TF | ELECTROLYTIC CAPACITOR 50V4.7uF |
| IC02 | 031 LA1266 | IC (FM-IF. AM-RF) |
| IC03 | 031 LA3401 | IC (FM-MPX) |
| IC01 | 031 LM7001JUM | IC (PLL) |

Parts List 3/4

| SYMBOL | PARTS NO. | DESCRIPTION |
|---------------------|------------------|--------------------------------|
| IC04 | 031 BU1920F | IC (RDS) |
| L01 | 021 2648601430 | MICRO INDUCTOR 20.8mH |
| C31 | 042 TP50V332J | MYLAR CAPACITOR 0.0033uF |
| C30,48 | 042 TP50V223J | MYLAR CAPACITOR 0.022uF |
| C32 | 042 TP50V393J | MYLAR CAPACITOR 0.039uF |
| RL57,RR57 | 055 ERJ6GEYJ152V | RESISTOR CHIP 1.5K |
| R35 | 055 ERJ6GEYJ182V | RESISTOR CHIP 1.8K |
| R16,34,39 | 055 ERJ6GEYJ101V | RESISTOR CHIP 100 |
| R01,04,06 | 055 ERJ6GEYJ104V | RESISTOR CHIP 100K |
| R07,27 | 055 ERJ6GEYJ103V | RESISTOR CHIP 10K |
| R11 | 055 ERJ6GEYJ181V | RESISTOR CHIP 180 |
| R10,17,18,19,38 | 055 ERJ6GEYJ102V | RESISTOR CHIP 1K |
| RL48,RR48 | 055 ERJ6GEYJ272V | RESISTOR CHIP 2.7K |
| R29,37 | 055 ERJ6GEYJ220V | RESISTOR CHIP 22 |
| R28,41,43 | 055 ERJ6GEYJ223V | RESISTOR CHIP 22K |
| R08,21 | 055 ERJ6GEYJ271V | RESISTOR CHIP 270 |
| RL46,RR46,RL47,RR47 | 055 ERJ6GEYJ274V | RESISTOR CHIP 270K |
| R56 | 055 ERJ6GEYJ225V | RESISTOR CHIP 2M2 |
| R13,33,42,RL49,RR49 | 055 ERJ6GEYJ332V | RESISTOR CHIP 3.3K |
| R31 | 055 ERJ6GEYJ392V | RESISTOR CHIP 3.9K |
| R20 | 055 ERJ6GEYJ331V | RESISTOR CHIP 330 |
| R26 | 055 ERJ6GEYJ393V | RESISTOR CHIP 39K |
| R24,30 | 055 ERJ6GEYJ472V | RESISTOR CHIP 4.7K |
| R05,15,22 | 055 ERJ6GEYJ471V | RESISTOR CHIP 470 |
| R36,40,44 | 055 ERJ6GEYJ473V | RESISTOR CHIP 47K |
| R02,32 | 055 ERJ6GEYJ562V | RESISTOR CHIP 5.6K |
| R09,12,14 | 055 ERJ6GEYJ561V | RESISTOR CHIP 560 |
| R03 | 055 ERJ6GEYJ623V | RESISTOR CHIP 62K |
| R50 | 055 ERJ6GEYJ681V | RESISTOR CHIP 680 |
| R25 | 055 ERJ6GEYJ683V | RESISTOR CHIP 68K |
| VR03 | 051 TRH063MCJ5R | SEMI-FIXED RESISTOR 220K |
| VR01 | 051 TRH063MCS3R | SEMI-FIXED RESISTOR 4.7K |
| VR02 | 051 TRH063MCS4R | SEMI-FIXED RESISTOR 47K |
| C15 | 044 S50V470PJ | STYROL CAPACITOR 50V470pF |
| ANT01 | 067 SC0210586N | TERMINAL ANTENNA |
| Q04,Q05,Q06,Q09 | 032 KRA107M | TRANSISTOR |
| Q03 | 032 KTC3194Y | TRANSISTOR |
| Q01,Q02,Q07 | 032 KTC3198Y-AT | TRANSISTOR |
| QL08,QR08 | 032 TDTC323TS | TRANSISTOR |
| TC01 | 045 TZ03N100 | TRIMMER 10pF TZ03N100FR169 |
| VD01,VD02 | 034 SVC321SPA-B2 | VARACTOR DIODE |
| ZD01,ZD03 | 034 TRD5.1JST1 | ZENER DIODE 5.1V (AB2) |
| OTHERS | | |
| | 505 FRT-02-B | FRONT PANEL ASSY (BLACK) |
| | 505 FRT-02-S | FRONT PANEL ASSY (SILVER) |
| | 069 C-4629A01 | AC 2P INLET 6102.3100 (WIRING) |
| | 072 C-4622A01 | AC CORD SET for AUSTRALIA |
| | 072 C-4624A01 | AC CORD SET for EUROPE |
| | 072 C-4623A01 | AC CORD SET for U.K |
| | 072 C-4620A01 | AC CORD SET for USA |
| | 021 RLA145A00 | AM LOOP ANT |
| | 081 UC3-07A00 | INSIDE CARTON |
| | 034 SEL1E24W | LED (BLUE) 1X5 |
| | 072 C-4738A01 | PIN PLUG CORD |
| | 019 4TSH-19#2 | PLASTIC FOOT 50 Φ |
| | 012 RV4-09A00 | PUSH BUTTON 14 Φ (BLACK) |
| | 012 RV4-09A01 | PUSH BUTTON 14 Φ (SILVER) |
| | 092 RR-T92 | REMOTE CONTROL UNIT |
| | 081 UC3-08A00 | SHIPPING CARTON |
| | 081 TZ-167 | STYROL SIDE MOULDING |

Parts List 4/4

| SYMBOL | PARTS NO. | DESCRIPTION |
|--------|---------------|---------------------------|
| | 012 UC3-03A01 | TACT BUTTON 15KEY(BLACK) |
| | 012 UC3-03A00 | TACT BUTTON 15KEY(SILVER) |
| | 012 UC3-04A01 | TACT BUTTON 2KEY(BLACK) |
| | 012 UC3-04A00 | TACT BUTTON 2KEY(SILVER) |
| | 014 C-4550A03 | UPPER COVER(BLACK) |
| | 014 C-4550A24 | UPPER COVER(SILVER) |
| | 082 OMRT-02-1 | OWNER'S MANUAL(EFGIDSSw) |
| | 072 4TR-3228 | FM DIPOLE ANT |

Tuner Adjustment Method

FM Section

* Necessary measurement equipment

RDS/STEREO Multiplexer, FM/AM Signal Generator, Audio Analyzer, Oscilloscope, Digital Volt Meter (DVM)

(A) Center adjust

RDS/STEREO Multiplexer Setting

- MODE : **MONO** - Audio Frequency : **1KHz**

FM Signal Generator Setting

- Deviation : **75KHz** - Radio Frequency : **98.1MHz** - Output Level : **66dB**

RT-02 Setting

- FM Frequency : **97.9MHz** - FM MODE : **MONO**

1. Turn FM Signal Generator Modulation on
2. Connect DVM (+)(-) terminals to **Jumper J7 and J8** and measure the volt.
3. If measured voltage is not adjusted within $\pm 10\text{mV}$, Make this measured volt '**0**' by adjusting **T04** (FM-DET-A Coil).
: **The adjustment should be within $\pm 10\text{mV}$**
4. After this adjustment, measure **THD**(Total Harmonic Distortion) with Audio Signal Generator
5. Adjust THD to minimum point with **T05**(FM-DET-B Coil). : **THD should be within 0.5%**

(B) Channel Separation adjust

RDS/STEREO Multiplexer Setting

- MODE : **STEREO (ONLY L-CH Signal OUT)** - Audio Frequency : **1KHz**

FM Signal Generator Setting

- Deviation : **75KHz** - Radio Frequency : **98.1MHz** - Output Level : **66dB**

RT-02 Setting

- FM Frequency : **98.1MHz** - FM MODE : **STEREO**

1. Turn FM Signal Generator Modulation on after **modulating only L-CH (or only R-CH)** at STEREO Multiplexer.
2. Confirm if '**STEREO**' indicator is **turned 'ON'** on the display
3. Measure output level via Audio Signal Analyzer and make the level as standard.
4. Turn FM Signal Generator Modulation on after **modulating only R-CH (or only L-CH)** at STEREO Multiplexer.
5. Measure output level via Audio Signal Analyzer (measure per a dB)
6. If measured output level is not lower than -40dB, Adjust output level to minimum position with **VR03** (CH-SEPA. ADJ.).
: **lower than -40dB**

(C) TUNED Level adjust

RDS/STEREO Multiplexer Setting

- MODE : **STEREO** - Audio Frequency : **1KHz**

FM Signal Generator Setting

- Deviation : **75KHz** - Radio Frequency : **98.1MHz** - Output Level : **26dB**

RT-02 Setting

- FM Frequency : **98.1MHz** - FM MODE : **STEREO**

1. Turn FM Signal Generator Modulation 'ON' (confirm if output level is **26dB**)
2. Change the output level of the Generator from 20dB to 30dB
and Confirm if 'STEREO' & 'TUNED' indicator of the DISPLAY turns on at 26dB(± 5 dB)
3. If these indicators do not turn on at higher than 26dB(± 5 dB) or do not turn off at lower than 26(± 5 dB) ,
Adjust **VR02 (FM-ADJ)** up to the moment where 'STEREO' & 'TUNED' indicator turns **OFF & ON** at 26dB.
4. Confirm if 'STEREO' & 'TUNED' turns OFF when decreasing the output level slowly from 26dB to 25dB, 24dB ~~~.
(Repeat the above 3. if not OFF in lower than 24dB.)
5. Push RT-02's TUNE UP or DOWN button "**long**" at Signal Generator Output Level 26dB and **start Auto search**.
Confirm if search **stops** at FM Frequency 98.1MHz.
(Examine both of High Freq. -> 98.1MHz search , Low Freq. -> 98.1MHz search)

AM Section

* Necessary measurement equipment :

AM Signal Generator, Audio Signal Analyzer, Dummy Load, Oscilloscope, Digital Volt Meter (DVM)

(A) VT adjust

AM Signal Generator Setting

1. Adjust AM Frequency of RT-02 to **522KHz. (or 520KHz)**
2. Connect (-) terminal of DVM with GND (or chassis) and connect (+) terminal with Jumper **J3** (VT CHECK) and measure voltage. (**Low Freq. VT**)
3. Adjust VT to 1.1V with **T02** (AM-OSC Coil).

* In case of **USA version**, AM freq. range is **520KHz ~ 1710KHz**. So, adjust as below.
at 520KHz, VT = 1.1V (Low Freq. VT)

(B) Output Level adjust

AM Signal Generator Setting

- Modulation : **30%** - Audio Frequency : **400Hz** - Output Level : **100dB**
- Radio Frequency : **603KHz (or 600KHz)**

RT-02 Setting

- AM Frequency : **603KHz/1404KHz/999KHz (or 600KHz/1400KHz/1000KHz)**

1. Turn AM Signal Generator Modulation ON
2. Adjust RT-02 AM Freq. to **603KHz (or 600KHz)** and measure output level with Audio Signal analyzer.
3. Adjust output level to maximum point with **T01** (AM-ANT).
4. Adjust AM Signal Generator & RT-02 AM Frequency to **1404KHz (or 1400KHz)** and measure output level.
5. Adjust output level to maximum point with **TC01 (White Trimmer)**.
6. Repeat above 2.~ 5. **steps** 2 ~ 3 times until adjusting to best output level.
7. Adjust AM Signal Generator & RT-02 AM Frequency to **999KHz (or 1000KHz)** and measure output level.
8. Adjust level to maximum position with **T03** (AM-IFT).

(C) TUNED Level adjust

AM Signal Generator Setting

- Modulation : **30%** - Audio Frequency : **400Hz** - Radio Frequency : **999KHz (or 1000KHz)**
- Output Level : **84dB**

RT-02 Setting

- AM Frequency : **999KHz (or 1000KHz)**

1. Turn AM Signal Generator Modulation ON (Make sure if Output level is **84dB**)
2. If 'TUNED' indicator does not turn on at higher than 80~86dB(Generator output),
Adjust **VR01** (AM-ADJ) up to the moment where 'TUNED' indicator turns OFF & ON again
3. Confirm if 'TUNED' turns OFF when decreasing the output level of AM Signal Generator slowly from 84dB to 80dB.
4. Push RT-02 **TUNE UP or DOWN** button "**long**" at AM Signal Generator Output Level 84dB and **start AUTO search**.
Confirm if search **stops** at AM Frequency 999KHz (or 1000KHz).
< Check with both of High Freq. -> 999KHz(or 1000KHz) search , Low Freq. -> 999KHz(or 1000KHz) search >

Conversion Frequency:

To set European Frequency - Press "POWER" button to ON while pressing "MEMORY" and "0" buttons.

And set De-Emphasis with 50uSEC on the TUNER PCB with JLE100/JRE100 ar connected by SHORTEN PLUGs.

To set European Frequency - Press "POWER" button to ON while pressing "MEMORY" and "9" buttons.

And set De-Emphasis with 75uSEC on the TUNER PCB with JLU100/JRU100 ar connected by SHORTEN PLUGs.

Case Outlines

RT-02



KRC107M KRA107M
DTC323TS

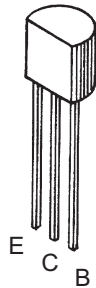

KTC3198

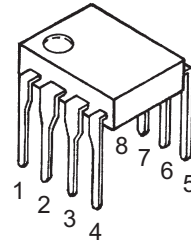

OPA2604P
AT24C16P

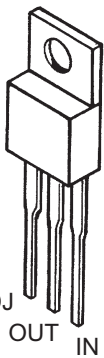

NJM317F

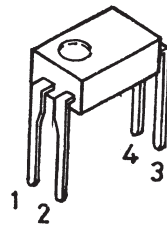

PC817B

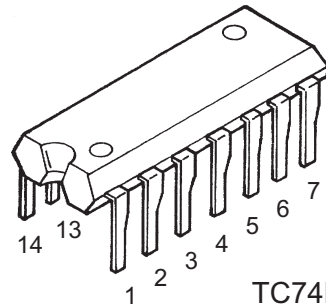

TC74HCU04AP

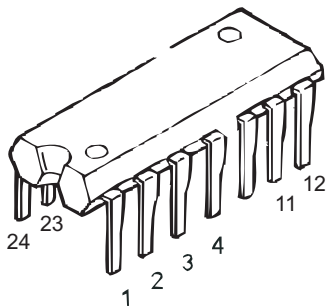

LA1266

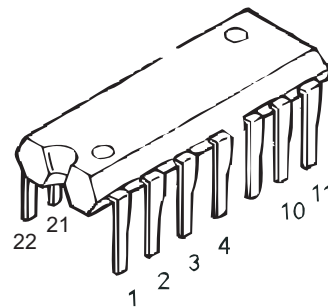

LA3401

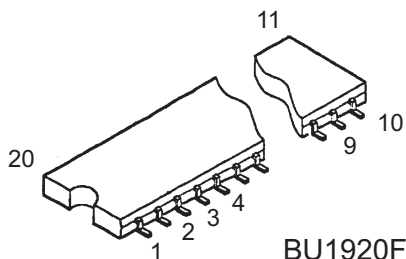

BU1920F
LM7001M

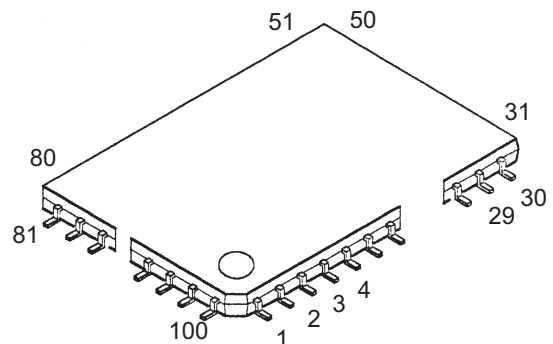

CXP82832-316Q

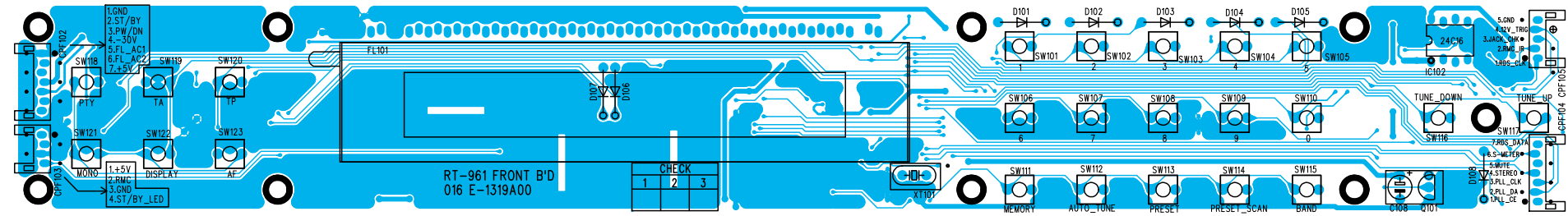

Front PCB 016 E-1319A00 Bottom Side

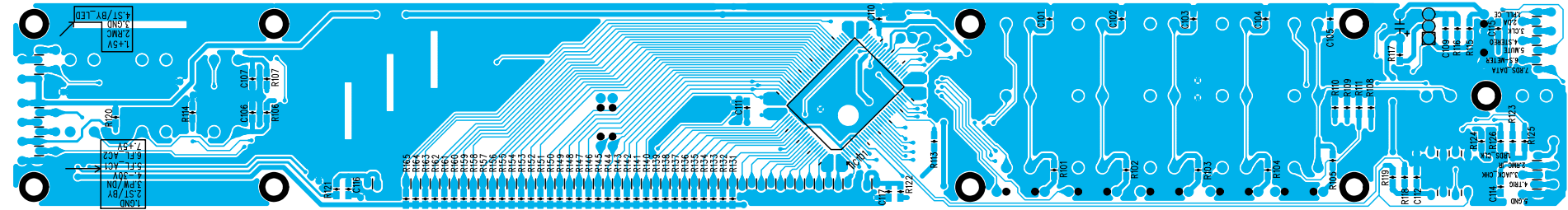

Main PCB 016 X-1320A01-04 Top Side

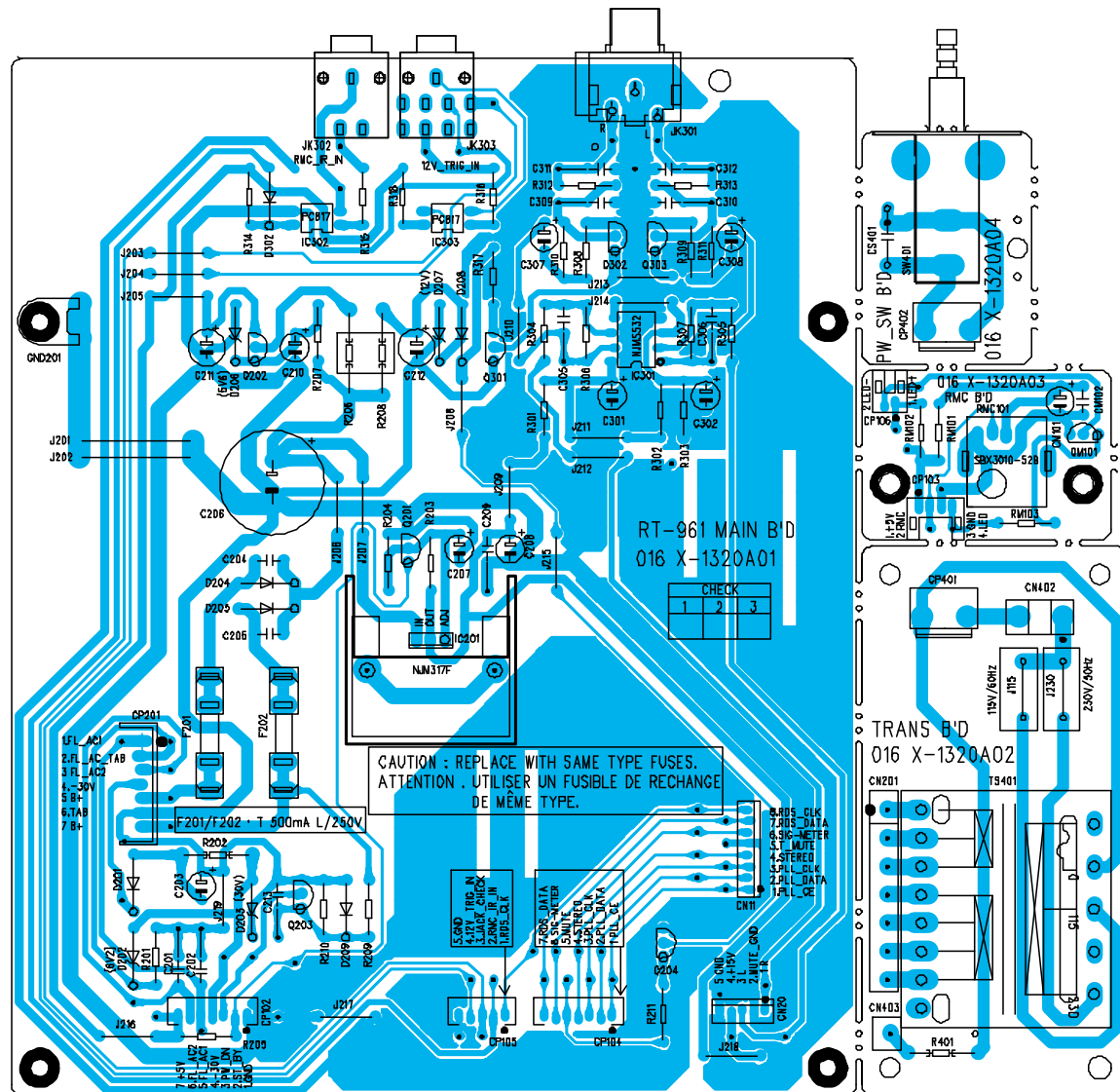

Main PCB 016 X-1320A01-04 Top Side

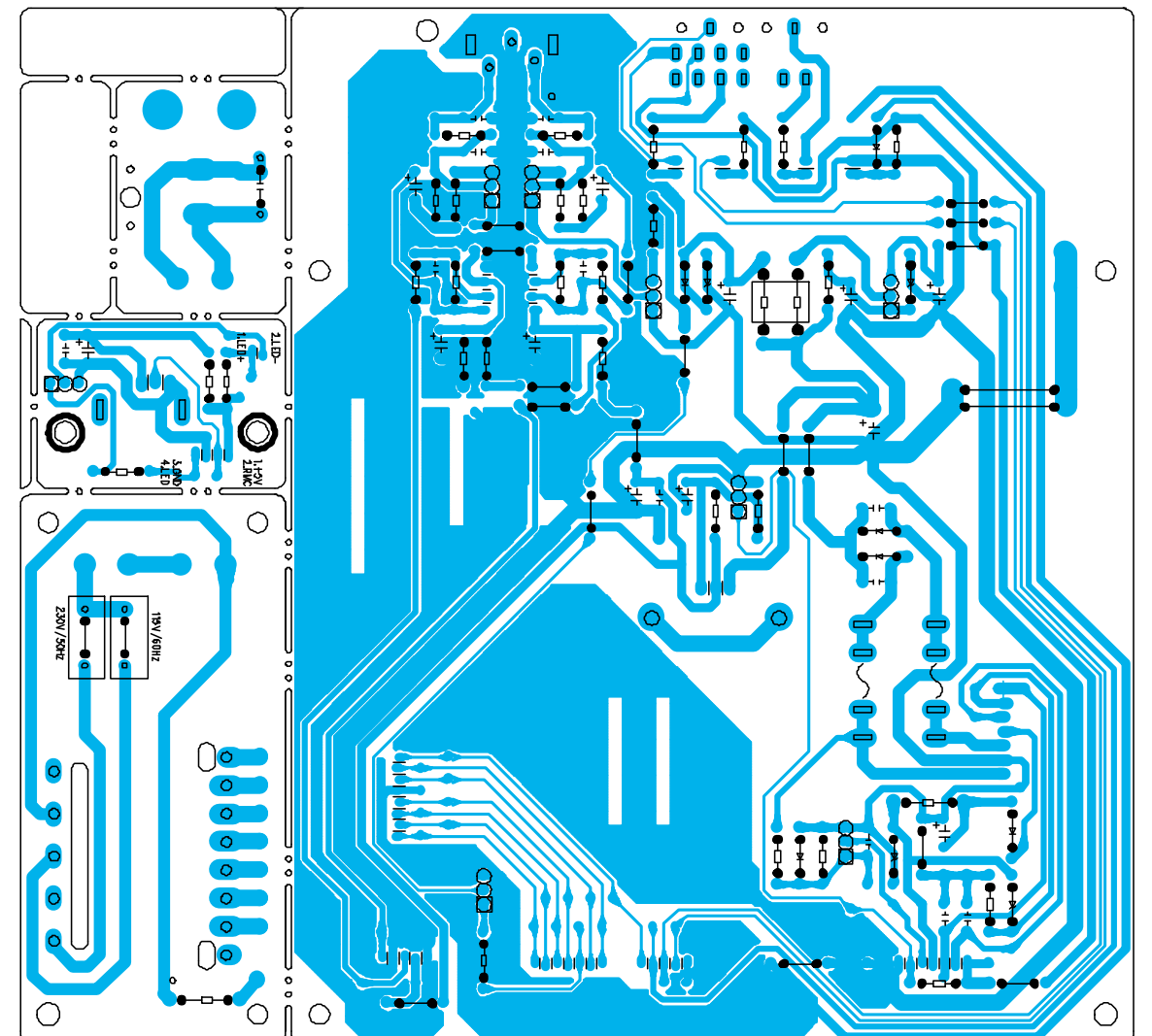

Tuner PCB 4002002300 Top Side View

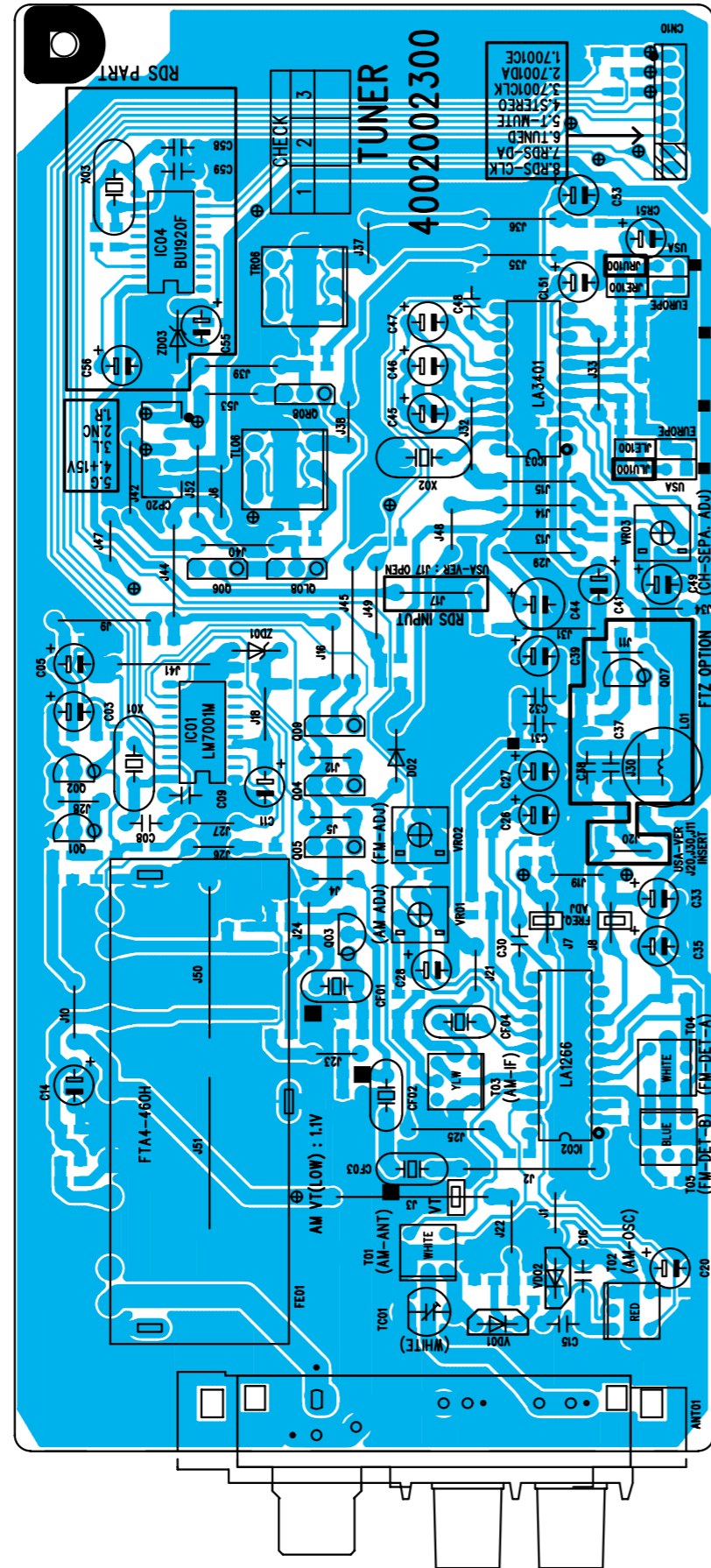

Tuner PCB 4002002300 Bottom View

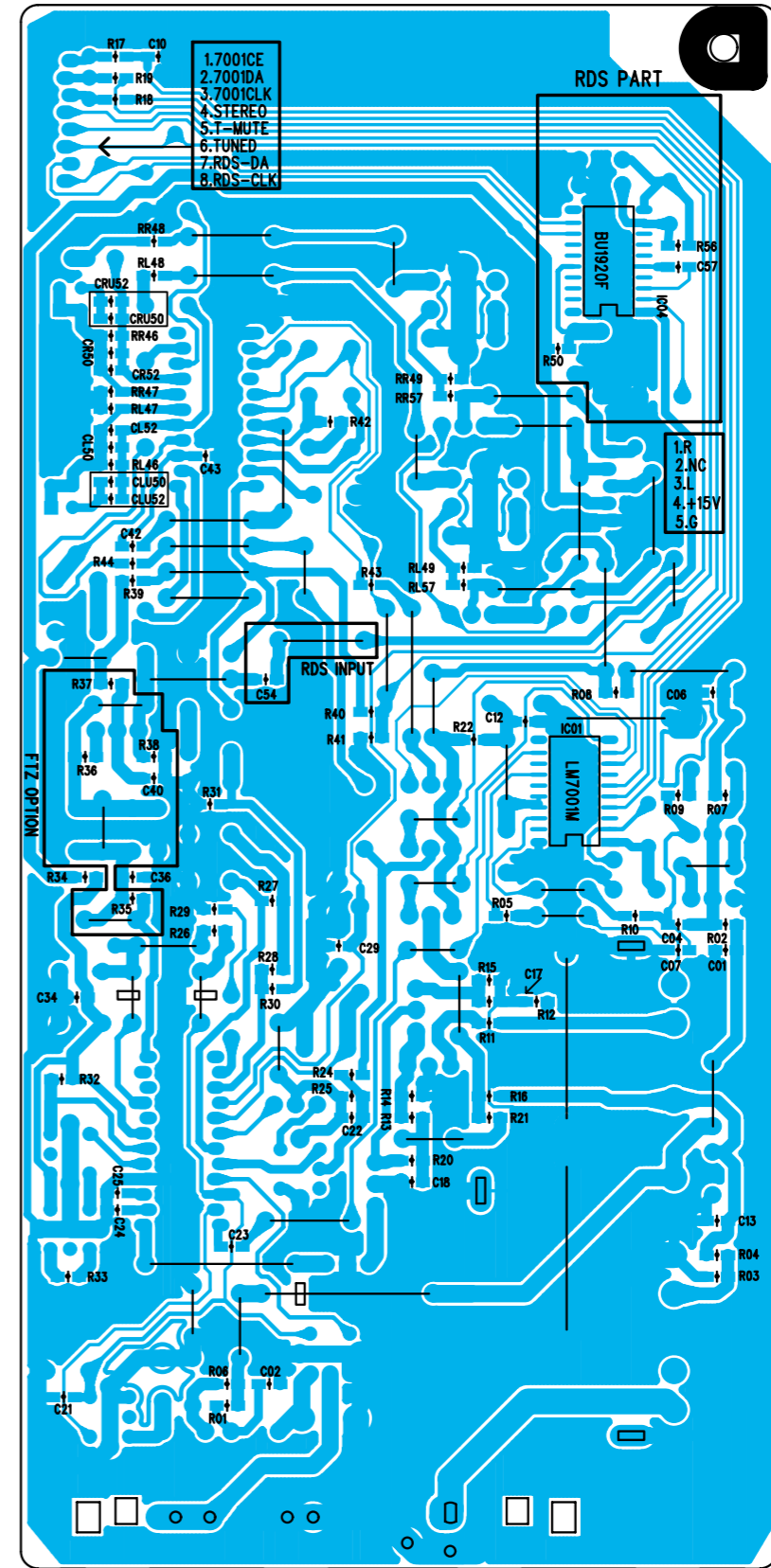

Wiring Diagram

RT-02

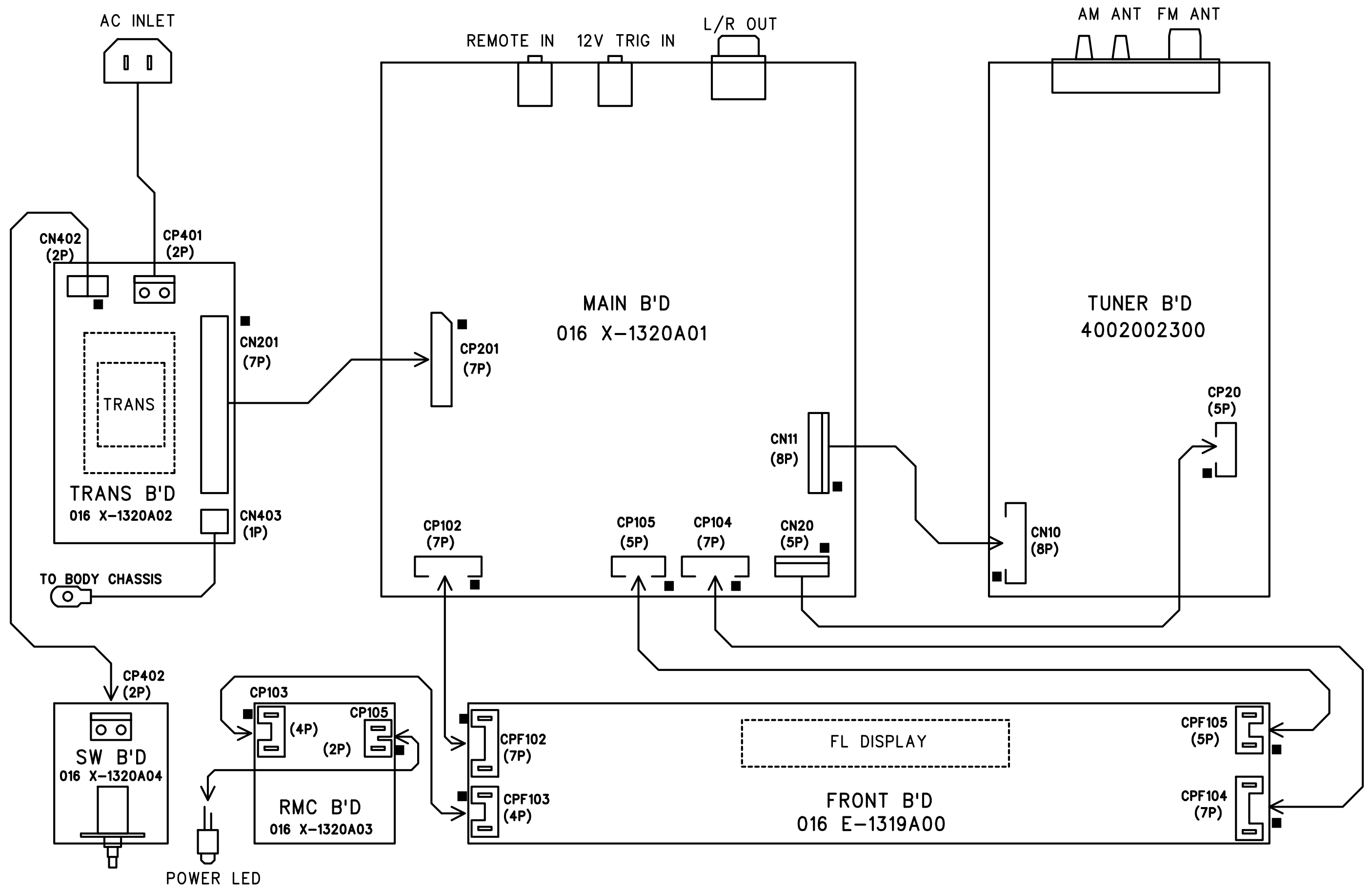

Schematic Diagram - 1

RT-02

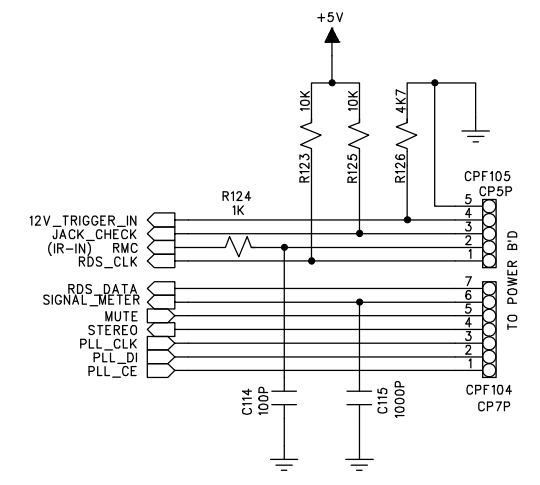
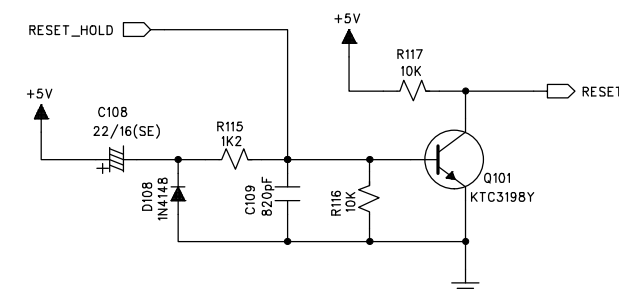
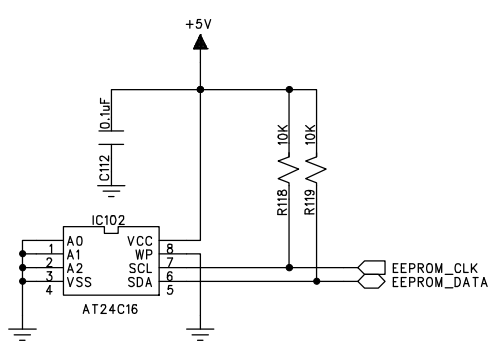
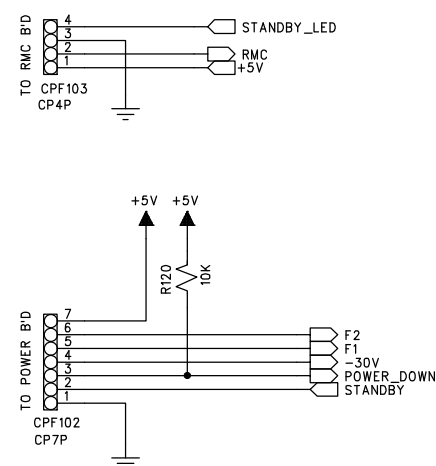
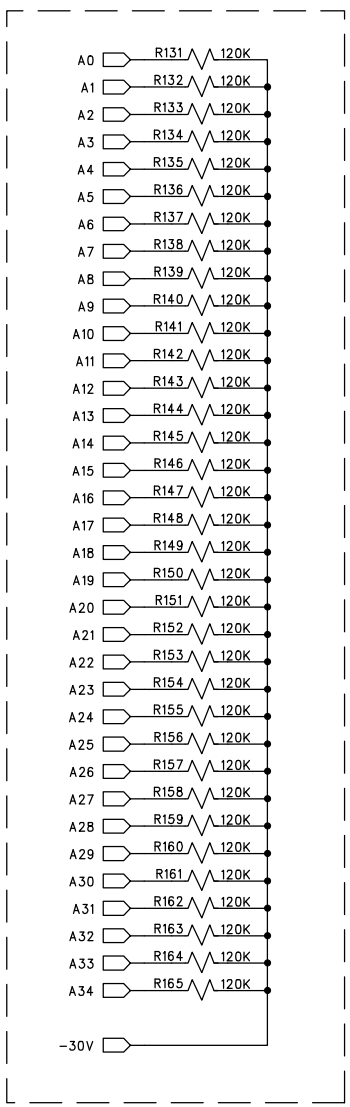
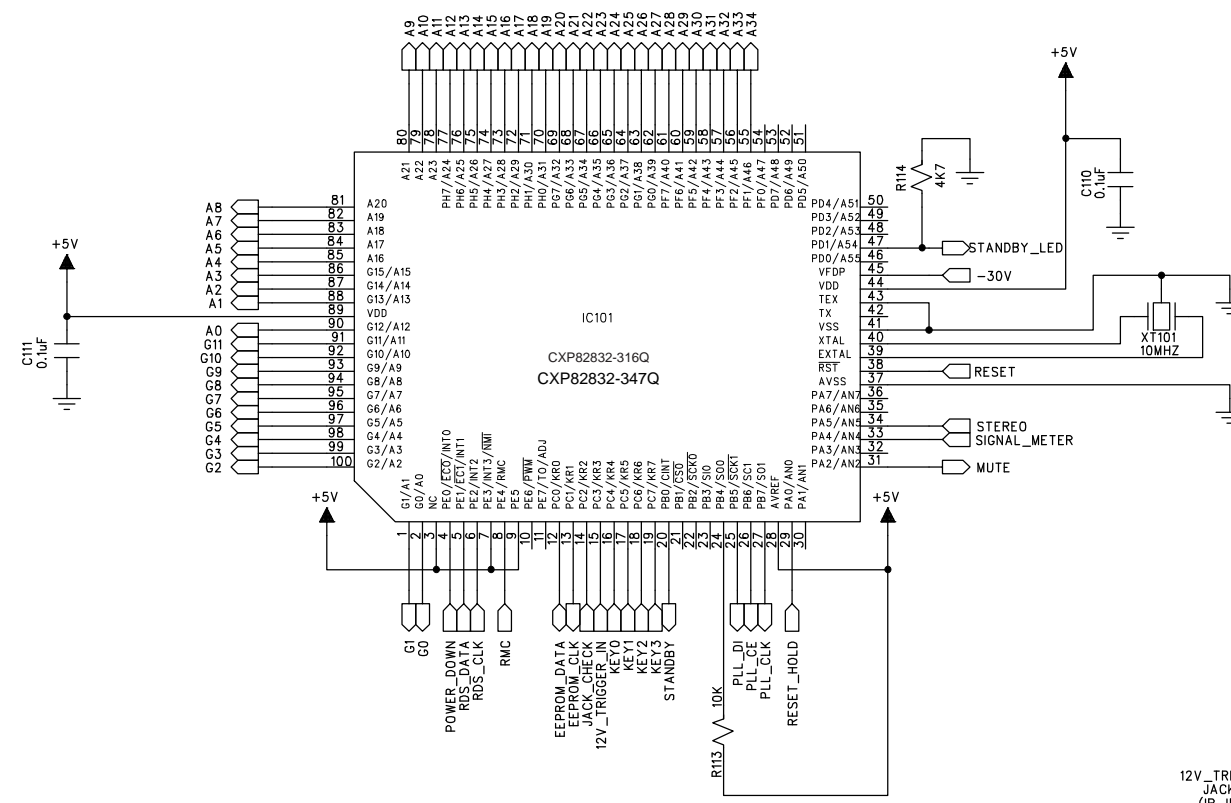
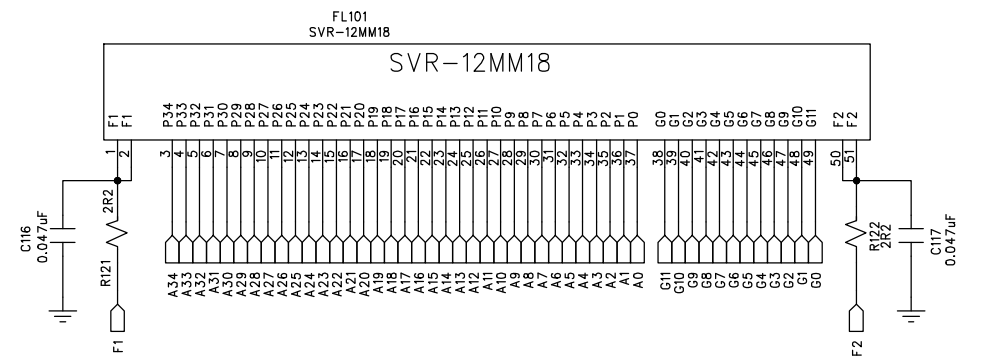
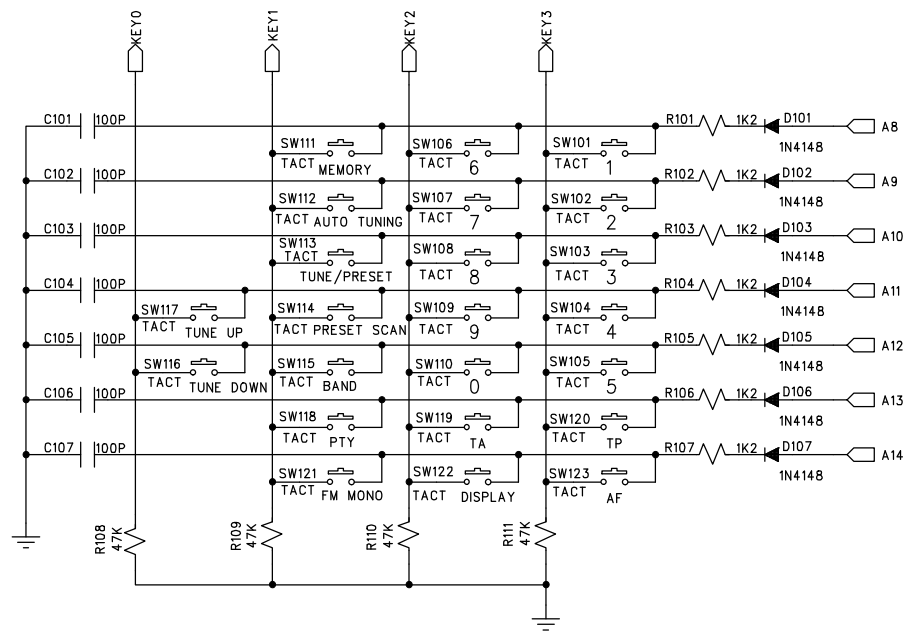

FRONT B'D
016 E-1319A00

Schematic Diagram - 2

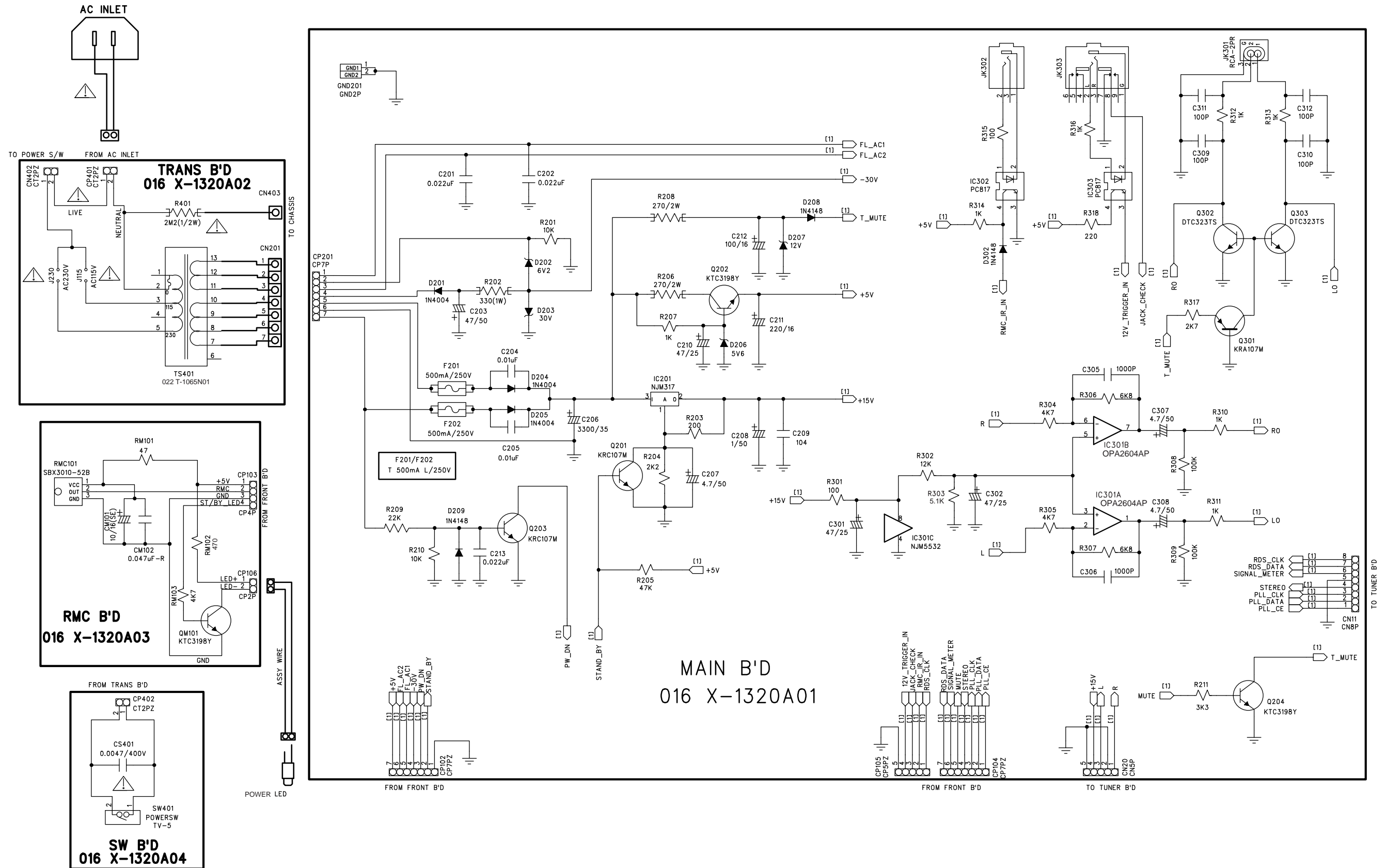

Schematic Diagram - 3

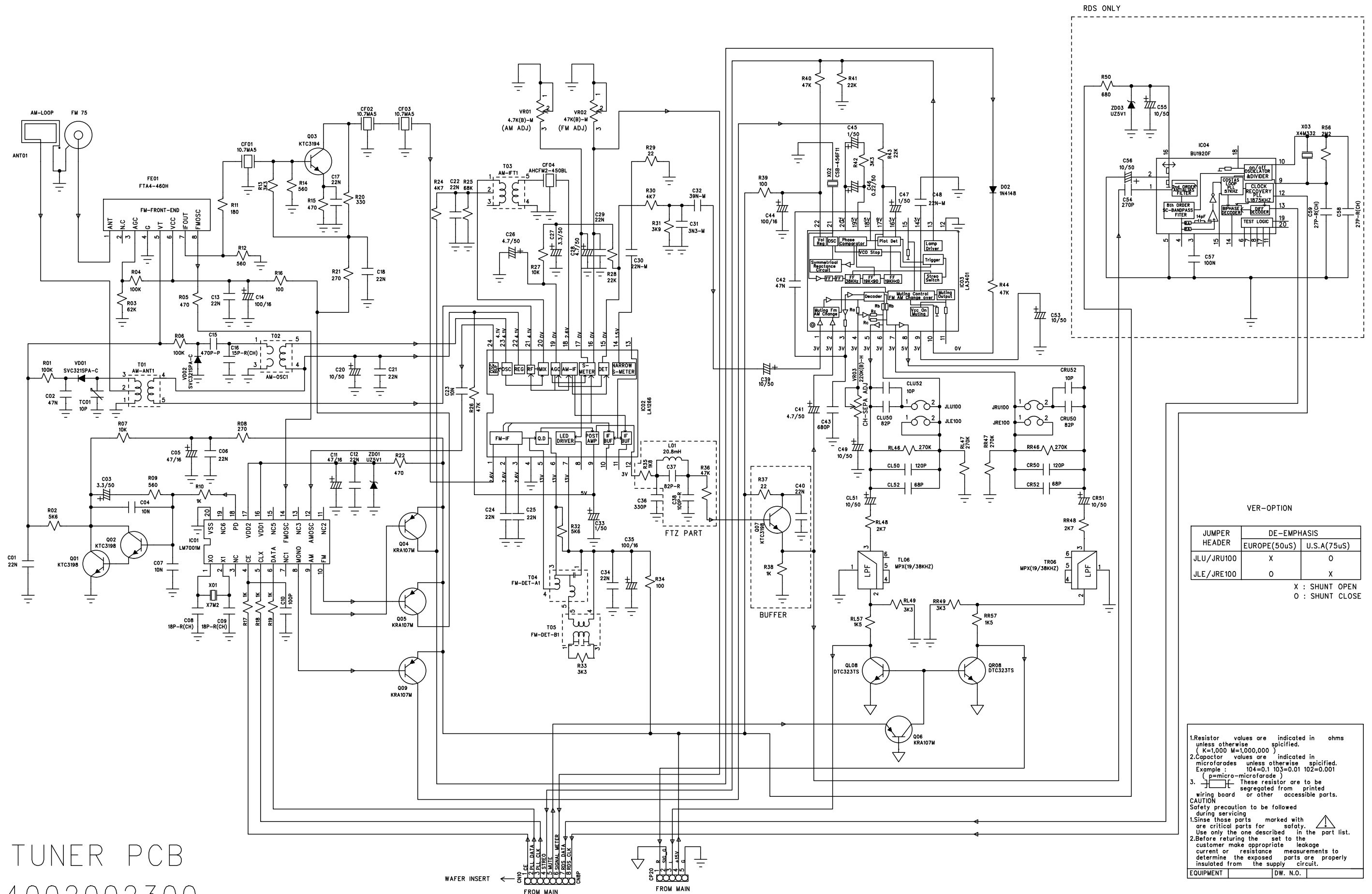

TUNER PCB
4002002300