

ROTEL®

RT-624 RT-824

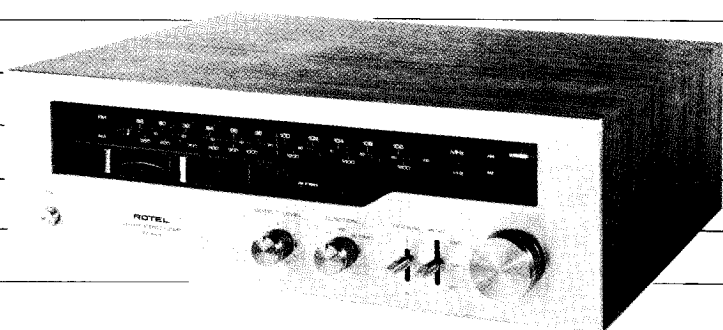

RT-624



RT-824

TABLE OF CONTENTS

RT624 CHASSIS LAYOUT	2	FM MPX ALIGNMENT HOOK-UP (RT-624/RT-824)	
RT824 CHASSIS LAYOUT	3	IF PCB LAYOUT (MPX PORTION)	
AM IF AND RF ALIGNMENT PROCEDURE	4	FM MPX ALIGNMENT PROCEDURE (RT-624/RT-824)	9
AM SIGNAL METER ADJUSTMENT (RT-824 ONLY)	4	FRONT END SCHEMATIC DIAGRAM	10
AM ALIGNMENT HOOK-UP (RT-624)		SCHEMATIC DIAGRAM RT-824	11 ~ 13
AM ALIGNMENT HOOK-UP (RT-824)	5	SCHEMATIC DIAGRAM RT-624	14 ~ 15
FM IF & RF ALIGNMENT PROCEDURE		RT624 AM/FM IF/MPX CIRCUIT BOARD DIAGRAM	16
FM SIGNAL METER LEVEL ADJUSTMENT		RT824 AM/FM IF/MPX CIRCUIT BOARD DIAGRAM	17
FM MUTING LEVEL ADJUSTMENT	6	AUDIOAMP CIRCUIT BOARD DIAGRAM RT-624, RT-824	18
RT-624 & RT-824 FM IF & RF ALIGNMENT HOOK-UP		CONTROL CIRCUIT BOARD DIAGRAM (RT-824 ONLY)	
RT-624 IF PCB AND FRONT-END LAYOUT		FM IF PREAMP CIRCUIT BOARD DIAGRAM (PT-824)	19
RT-824 IF PCB AND FRONT-END LAYOUT	7	POWER SUPPLY CIRCUIT BOARD DIAGRAM (RT-624)(RT-824)	
FM MONO-STEREO AUTO-SWITCHING		DIAL STRINGING DIAGRAM (RT-624)(RT-824)	20
LEVEL ADJUSTMENT PROCEDURE (RT-624 · RT-824)		REPAIR PARTS LIST (RT-624)	21
FM MPX ALIGNMENT PROCEDURE (RT-624 · RT-824)	8	REPAIR PARTS LIST (RT-824)	22

TECHNICAL MANUAL

RT624 CHASSIS LAYOUT

CHASSIS TOP VIEW

1. IF Circuit Board
2. L303, FM MPX Low Pass Filter
3. VR306, FM Stereo Separation Adj.
4. VR302, FM Muting Level (30 μ V) Adj.
5. VR301, FM Muting Level (10 μ V) Adj.
6. VR304, FM Stereo Auto-Switching Level Adj.
7. VR303, FM Signal Meter Level Adj.
8. L301, FM IFT, 10.7MHz Tune
9. L105, AM IFT, 2nd
10. Meter Light
11. T001, Power Transformer
12. AM/FM Front-End
13. L103, AM OSC Coil
14. Power Supply Circuit Board
15. L104, AM IFT, 1st
16. L101, FM IFT, Ratio (Pri.)
17. L102, FM IFT, Ratio (Sec.)
18. VR305, FM MPX, 19kHz Adj.
19. S5, FM De-emphasis Switch
20. L004, AM Antenna Coil

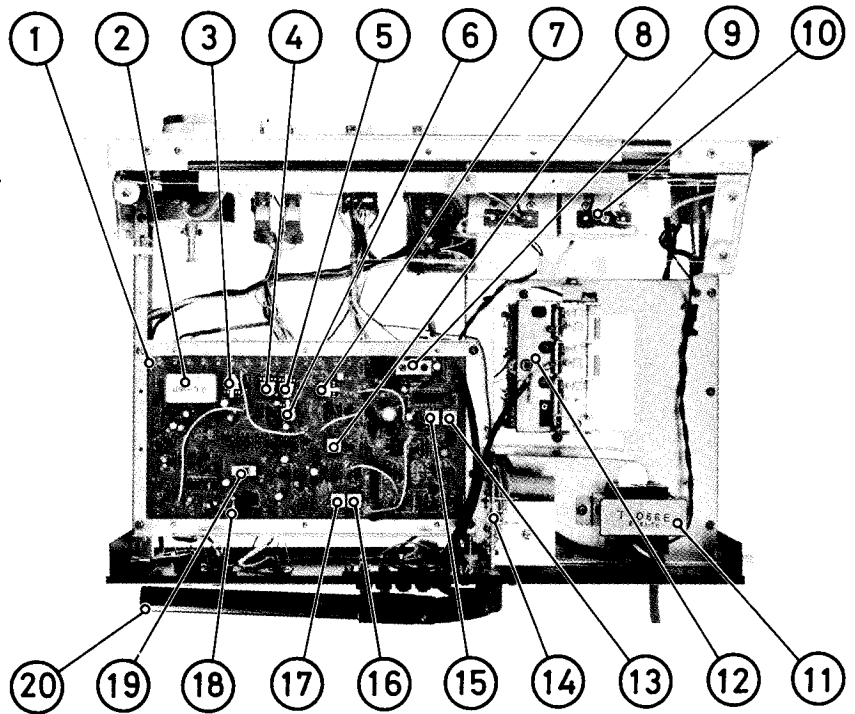

CHASSIS BOTTOM VIEW

21. S4, Power Supply Switch
22. M001, Signal Meter
23. M002, Tuning Meter
24. Audio Amp. Circuit Board
25. Output Level Control
26. S1, Function Selector Switch
27. S2, FM Hi-Blend Switch
28. S3, FM Muting Switch
29. Tuning Knob
30. Output Terminal
31. FM 4-ch. Det. Output Terminal
32. AM/FM Antenna Terminal
33. AC Output
34. AC Fuse

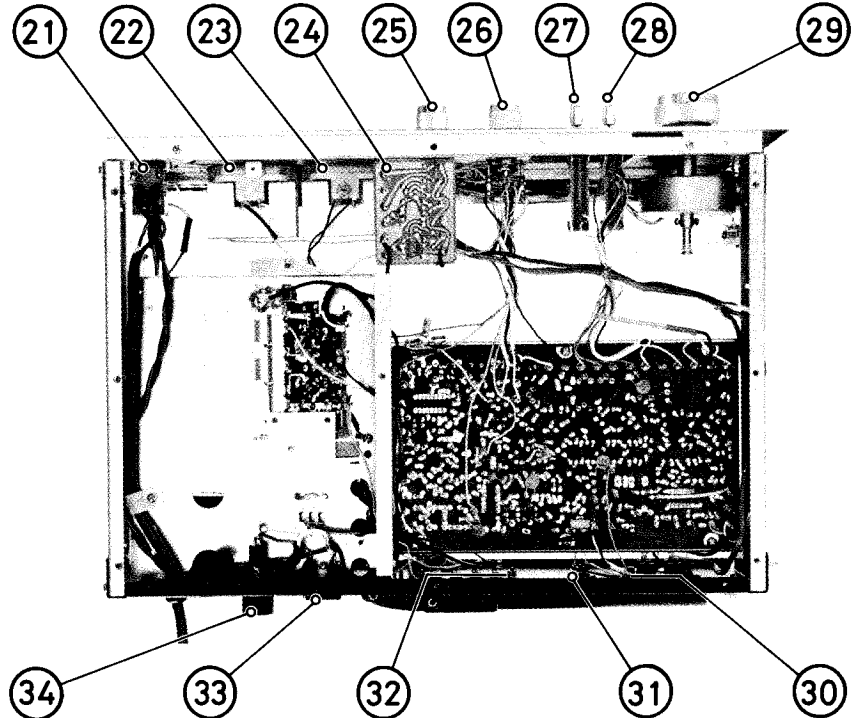

RT824 CHASSIS LAYOUT

CHASSIS TOP VIEW

1. VR802, FM Muting Level (30 μ V) Adj.
2. Tuning Knob
3. VR801, FM Muting Level (10 μ V) Adj.
4. Control Circuit Board
5. S1, Function Selector
6. Output Level Control
7. L104, FM IFT, Ratio (Sec.)
8. L103, FM IFT, Ratio (Pri.)
9. Phones Volume Control
10. S5, Power Switch
11. AM/FM Front-end
12. AM/FM IF Amp. Circuit Board
13. VR201, AM Signal Meter Level Adj.
14. CT202, AM RF Trimmer
15. L204, AM RF Coil
16. Tool, Power Transformer
17. Voltage Selector
18. Power Supply Circuit Board
19. CT203, AM OSC Trimmer
20. CT201, AM Antenna Trimmer
21. L205, AM OSC Coil
22. L206, AM IFT
23. VR202, AM Signal Meter "ZERO" Adj.
24. L003, AM Antenna Coil
25. VR101, FM Signal Meter Level Adj.
26. L101, FM IFT
27. VR104, FM Stereo Separation Adj.
28. L105, FM Low Pass Filter
29. VR102, FM Stereo Auto-Switching Level Adj.
30. VR103, FM MPX 19kHz Adj.
31. S6, FM De-emphasis Switch

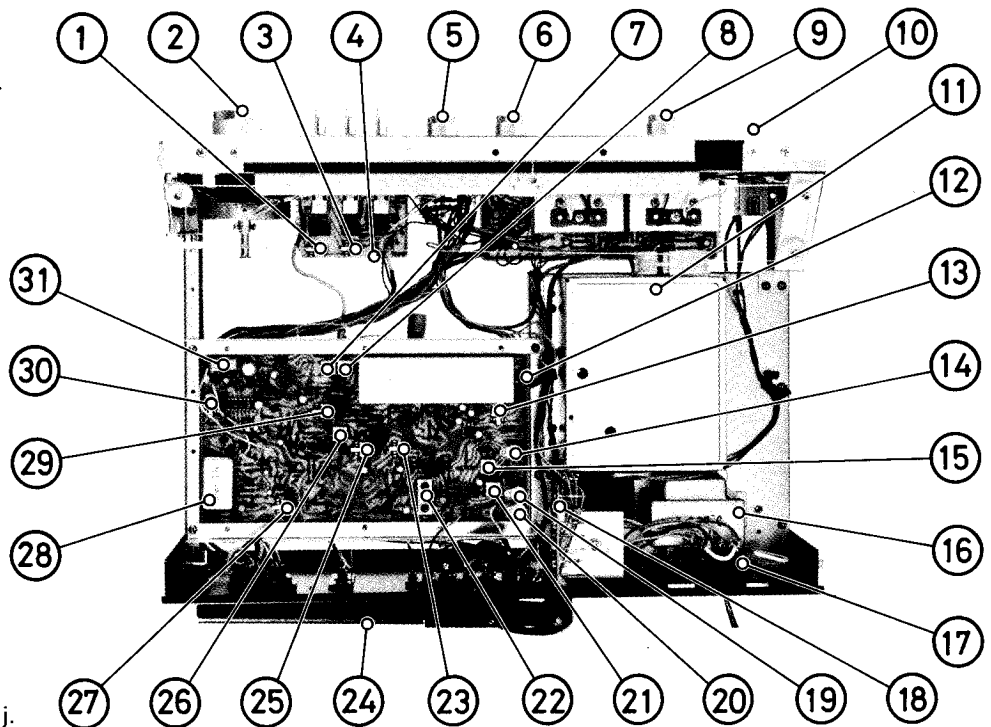

CHASSIS BOTTOM VIEW

32. Audio Amp. Circuit Board
33. S2, Hi-Blend Switch
34. S3, Multi-path Switch
35. S4, Muting Switch
36. Output Jack
37. FM 4-ch. Signal Output Jack
38. Antenna Terminal Strip
39. AC Outlet
40. AC Fuse

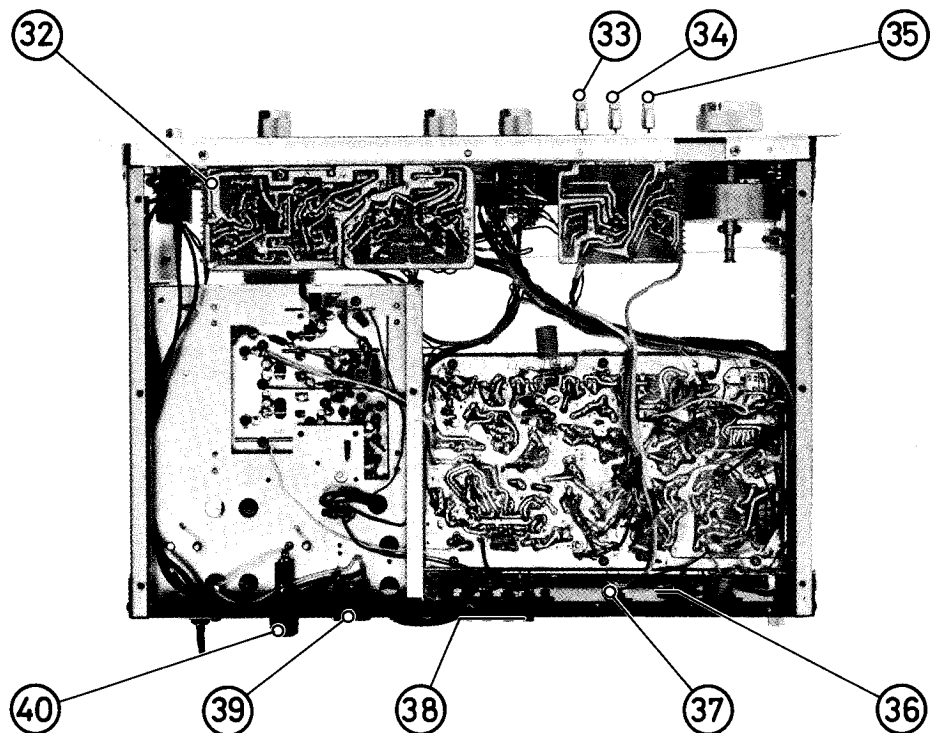

AM IF & RF ALIGNMENT PROCEDURE

Instruments: AM Signal Generator and AC VTVM.

Notes: Set Function Selector to AM position.

Input signal must be kept as low as possible to avoid AVC action.

Step	Generator		Tuning Dial Setting	Output Indicator	Adjust	Adjust for
	Connected to	Frequency		Connected to		
1	Pin No.3 = RT-624, Pin No.4 = RT-824, (on IF pcb) thru a 0.01 mfd capacitor	455 kHz (400 Hz 30% Mod.)	Non interfering at at low end of scale	AC VTVM to OUTPUT jack	L105 and 104 = RT- 624, L206 = RT-824, (on IF pcb)	Maximum reading on AC VTVM.
2	Test Loop Radiate signal into ferrite loopstick antenna	600 kHz (400 Hz 30% Mod.)	600 kHz on Dial scale		L103 (OSC) and 004 (ANT) coil = RT-624 L205, (OSC), L204 (RF) and 003 (ANT) coil = RT-824	
3		1400 kHz (400 Hz 30% Mod.)	1400 kHz on Dial scale		CT6 (OSC) and CT5 (ANT) = RT-624, CT203 (OSC), CT202 (RF) and CT201 (ANT) = RT-824	
4	Repeat steps 2 and 3 until further improvement is noticed.					

AM SIGNAL METER ADJUSTMENT (RT-824 ONLY)

1. Adjust the potentiometer VR202 so as to indicates "0" point at no signal input.
2. Then adjust the potentiometer VR201 so as to indicates "8" point at 1,000 kHz 50mV/m signal input.

AM ALIGNMENT HOOK-UP (RT624)

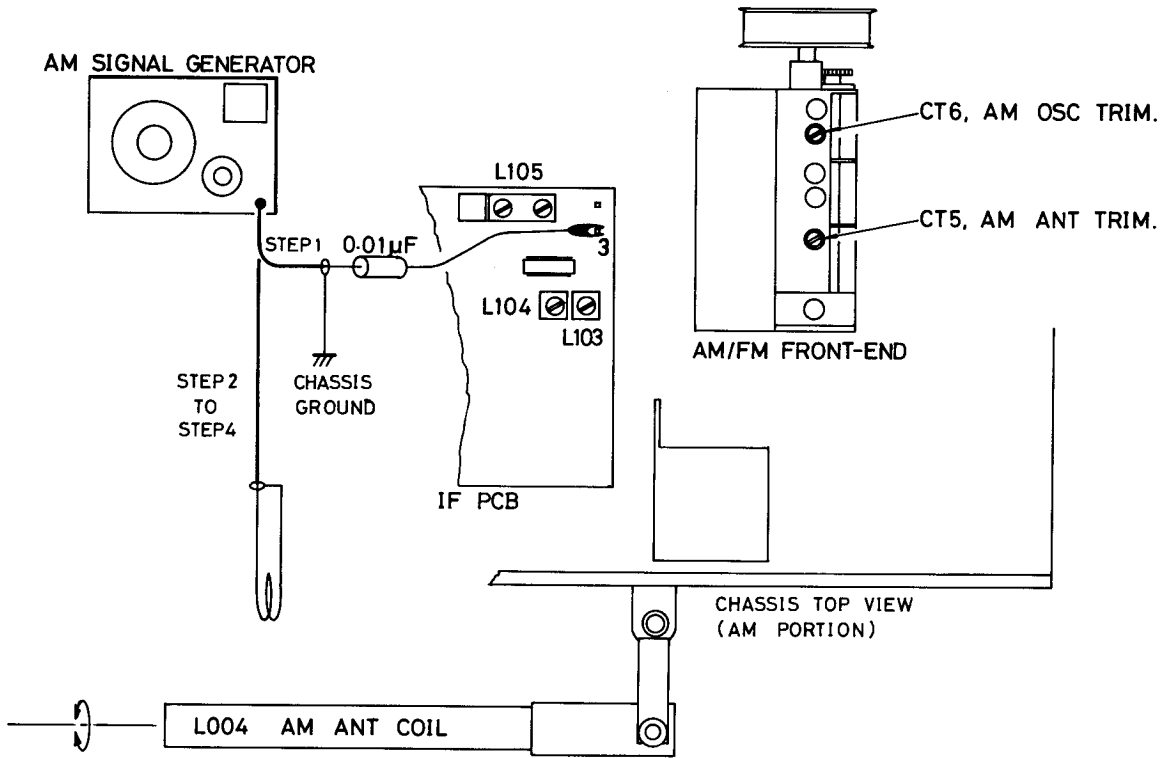

Fig.1-1

AM ALIGNMENT HOOK-UP (RT824)

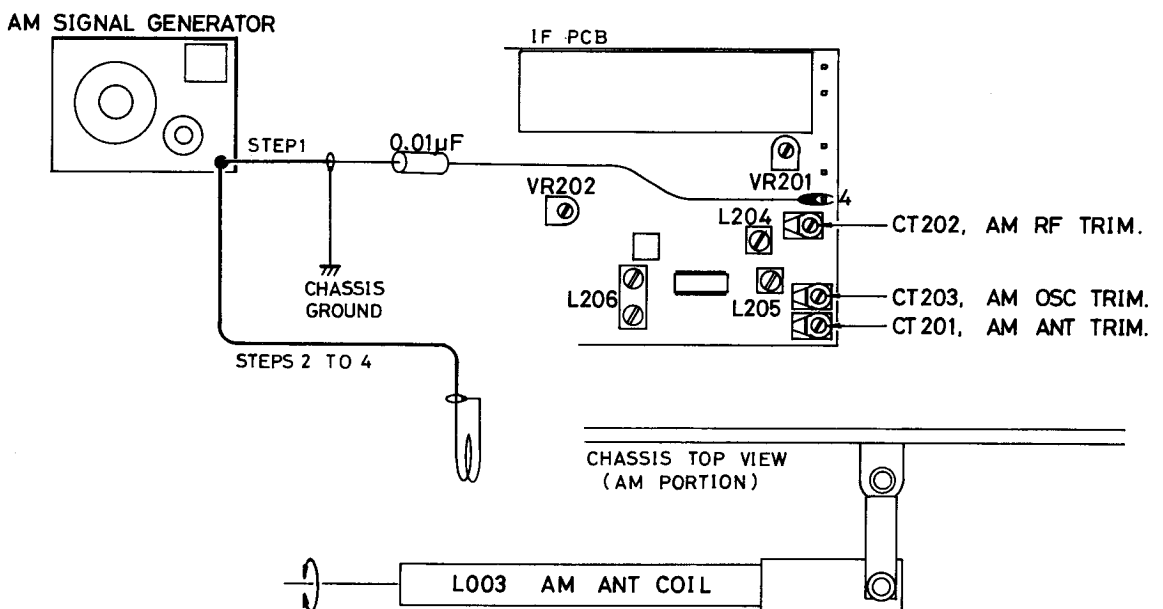

Fig.1-2

FM IF & RF ALIGNMENT PROCEDURE

Instruments: FM Signal Generator and H.D. Analyzer
Set Function Selector to "FM" (RT-624); "FM AUTO" (RT-824).

Step	Generator		Tuning Dial Setting	Output Indicator Connected to	Adjust	Adjust for
	Connected to	Frequency				
1	No signal input		Non interfering appears on band	FM Tuning Meter (M002)	L102 = RT-624, L104 = RT-824 (on IF pcb)	FM Tuning Meter indicates the Center of the scale
2	To FM antenna terminals	98 MHz (400 Hz 100% Mod.)	FM Tuning Meter indicates the center of the scale	H.D. Analyzer To output jack	T1 (on Front-end)	Maximum reading on level meter of H.D. Analyzer
3					L101 = RT-624, L103 = RT-824, (on IF pcb)	Minimum reading on Distortion meter of H.D. Analyzer
<p>Note: When the indication of FM Tuning meter is off from the center of the scale in spite of the above adjustment Step 3, fine adjust L102 = RT-624, L104 = RT-824, so that the FM Tuning meter just indicates center point.</p>						
4	To FM antenna terminals	90 MHz (400 Hz 100% Mod.)	90 MHz on dial scale	H.D. Analyzer To output jack	L4 (OSC), L3, 2 (RF) and L1 (ANT) = RT-624 L0 (OSC), LR3, LR2, LR1 (RF) and LA (ANT) Coil = RT-824	Maximum reading on level meter of H.D. Analyzer
5		Note: Signal strength must be kept-3dB of limiter saturation	106 MHz (400 Hz 100% Mod.)		106 MHz on dial scale	
6	Repeat the above steps 4 and 5 until no further improvement is noticed.					

FM SIGNAL METER LEVEL ADJUSTMENT

Set Signal Generator frequency to 90 MHz, and set the FM antenna input level to 1mV by controlling the ATT of Signal Generator.

Receive the signal from Signal Generator, and adjust potentiometer, VR303 = RT-624, VR101 = RT-824, (on IF pcb) so that the Signal Meter indicates toward "9" on the scale.

FM MUTING LEVEL ADJUSTMENT

Instruments: FM Signal Generator and Oscilloscope.

1. Connect FM Signal Generator to FM antenna terminals. Set Signal Generator frequency to 90 MHz and adjust attenuator to obtain the antenna input level of 30 μ V.
2. Receiving the signal, adjust FM IFT, L301 = RT-624, L101 = RT-824, to obtain maximum reading on Signal Meter (M001). Then, set Muting switch to

"30 μ V" position, and adjust potentiometer, VR302 = RT-624, VR802 = RT-824, until the waveform on the oscilloscope vanishes.

3. Change the Muting switch to "10 μ V" position. Set the antenna input level to 10 μ V and adjust potentiometer, VR301 = RT-624, VR801 = RT-824, until the waveform on the oscilloscope vanishes.

RT-624 & RT-824 FM IF & RF ALIGNMENT HOOK UP

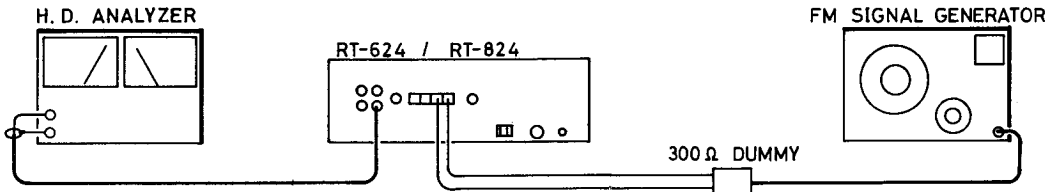

Fig. 2-1

RT-624 IF PCB AND FRONT-END LAYOUT

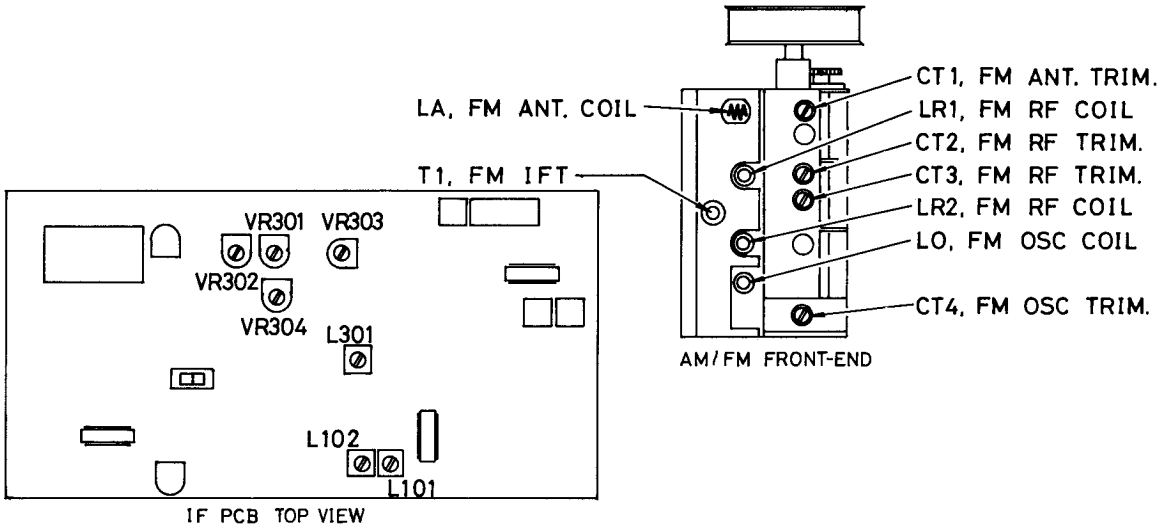

Fig. 2-2

RT-824 IF PCB AND FRONT-END LAYOUT

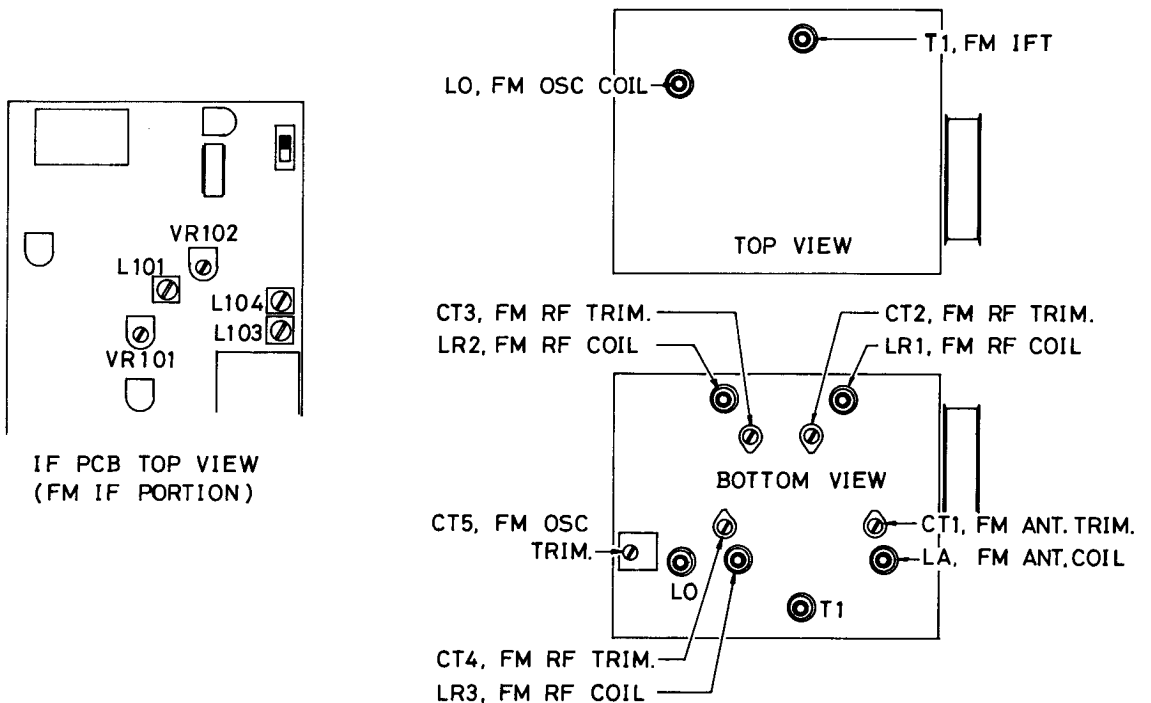

Fig. 2-3

FM MPX ALIGNMENT PROCEDURE (RT-624·RT-824)

Note: The FM IF amplifier alignment must be completed before attempting this MPX alignment. Poor FM IF alignment will result in poor multiplex adjustment.

Instruments: FM Stereo Generator, AC VTVM and Oscilloscope.

- a. Set Function Selector to "FM Stereo" = RT-624, "FM AUTO" = RT-824,
- b. Set Muting and Hi-Blend switch to "OFF".
- c. Connect FM Stereo Generator to FM antenna terminals, and set the frequency at 98 MHz (if a disrupting signal appears, select another frequency).

d. FM Stereo Generator modulation is as follows:
Pilot Signal 10%
Modulation frequency 1 kHz (L-ch.) 90%

1. Connect Oscilloscope and AC VTVM to OUTPUT (Right channel) jack. Receiving FM Stereo Generator signal, rotate and set the potentiometer, VR305 = RT-624, VR103 = RT-824, at the middle of range in which Stereo Indicator lights up.
2. Then rotate and adjust potentiometer, VR306 = RT-624, VR104 = RT-824, so that the leakage of signal into Right channel is minimum.

3. Switch the modulation of FM Stereo Generator from Left to Right, and reconnect oscilloscope and AC VTVM to OUTPUT (Left channel) jack. Then make certain the level of signal leakage into Right channel is equal to that into Left channel in preceding two items. If there is an excessive difference between leak-free effects of both channels, slightly adjust VR306 = RT-624, VR104 = RT-824, so that the levels of signal leakage of both channels are equal.

Separation subsequent to adjustment is as follows:

Frequency	RT-624	RT-824
1 kHz	33dB or more	35dB or more
100 Hz	30dB or more	30dB or more
10 kHz	20dB or more	28dB or more

4. After reducing the modulation of pilot signal of Stereo Generator to zero, increase it gradually and make certain the Stereo indicator lights up when the modulation degree comes to 5%.

FM MONO-STEREO AUTO-SWITCHING LEVEL ADJUSTMENT PROCEDURE (RT-624·RT-824)

1. Connect a VTVM and Oscilloscope to the OUTPUT jack (LEFT or Right).

2. Feed the FM signal whose MPX has been varied into the FM ANT terminals.

MPX VARIATION:

Pilot 10%
Modulation Frequency 1KHz Left or Right
RF Deviation ± 45 KHz

3. Set the frequency at 98 MHz (when there is a disrupting signal, choose another setting).

4. Set Function Selector "FM Stereo" = RT-624, "FM AUTO" = RT-824.

5. Set potentiometer, VR304 = RT-624, VR102 = RT-824, to mid-positions.

6. Adjust the FM MPX so that the distortion and separation will be best.

7. Adjust the VR304 = RT-624, VR102 = RT-824; so that when the antenna input level is $5\mu V$, Stereo will switch in and when the input is below the $5\mu V$ level, Mono will switch in.

8. After adjustment, check to make sure that, indeed, when the antenna input level exceeds $5\mu V$, Stereo will switch in.

FM MPX ALIGNMENT HOOK-UP (RT-624/RT-824)

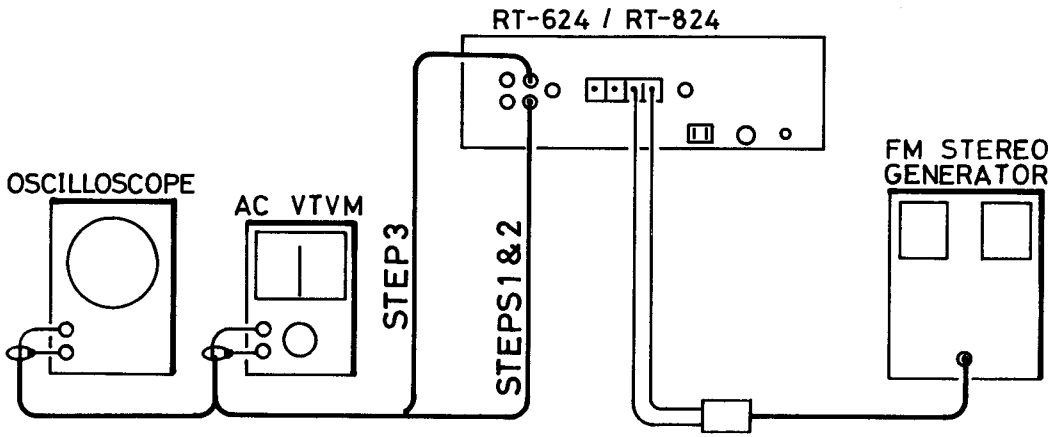
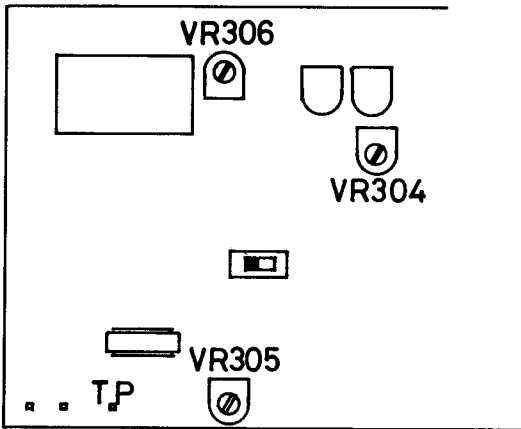

Fig. 3-1

IF PCB LAYOUT (MPX PORTION)

RT-624

RT-824



IF PCB TOP VIEW (MPX PORTION)

Fig. 3-2

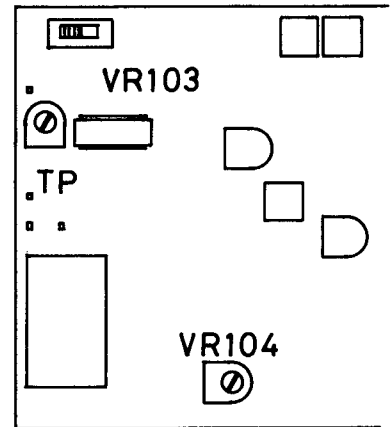

IF PCB TOP VIEW (MPX PORTION)

Fig. 3-3

FM MPX ALIGNMENT PROCEDURE (RT-624 / RT-824)

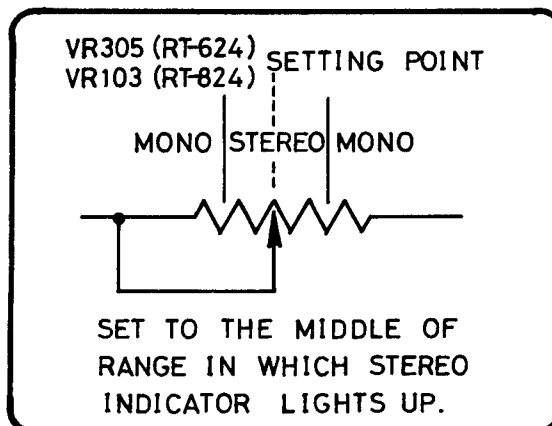
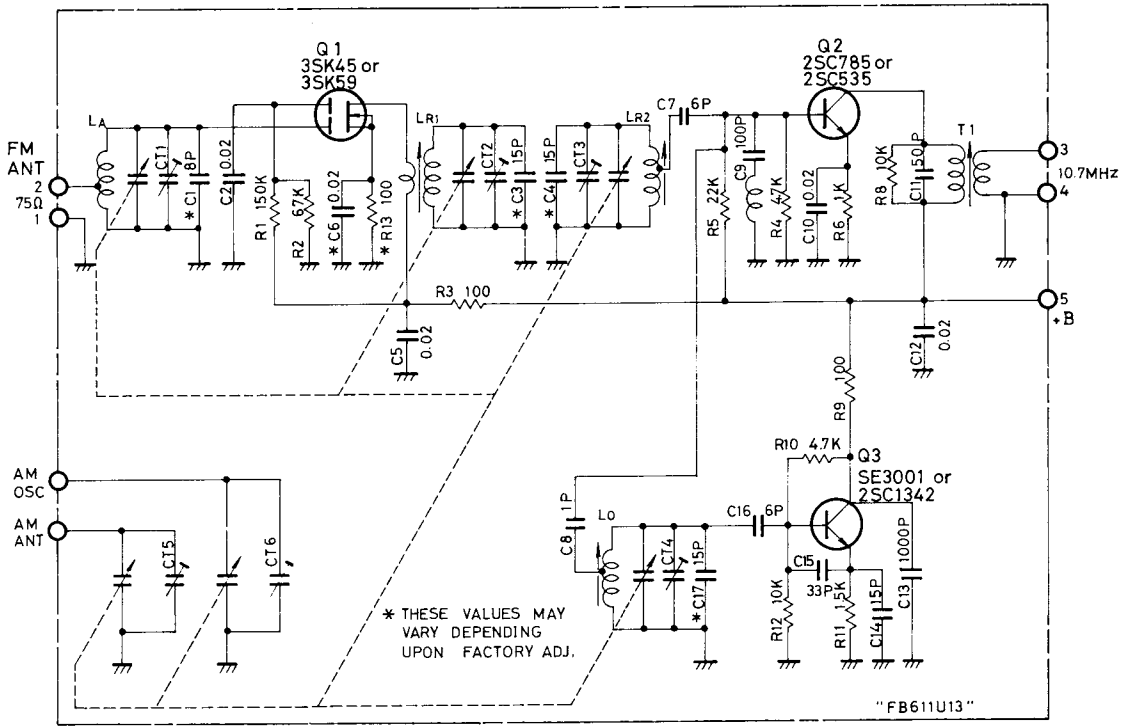

Fig. 3-4

FRONT-END SCHEMATIC DIAGRAM

RT-624



RT-824

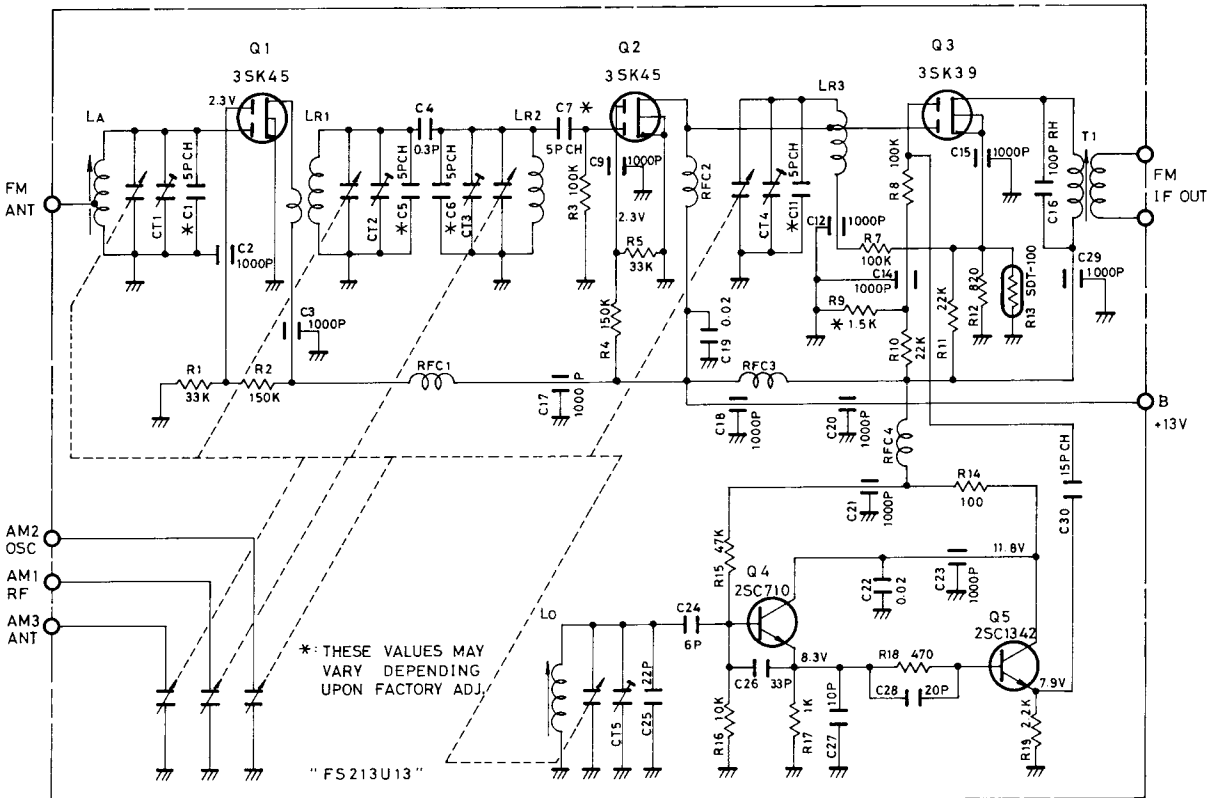

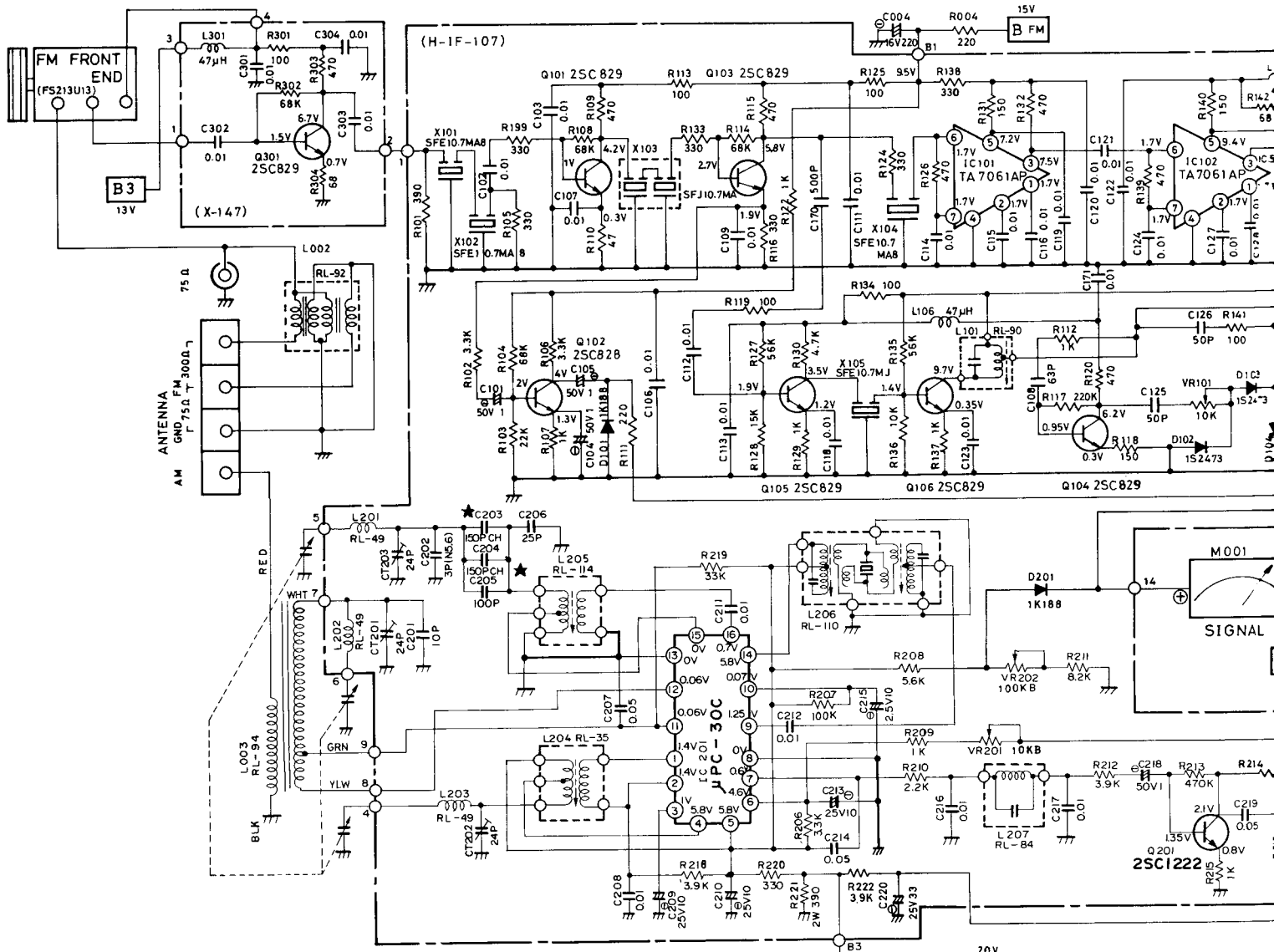

	MUTING OFF			MUTING ON WITH NO SIGNAL		
	B	C	E	B	C	E
Q 111	0.6V	0V	—	0.1V	1.3V	—
Q 112	5.6V	—	0V	1V	—	0.9V
Q 113	0.72V	0V	0V	0.25V	—	0.9V
Q 114	0V	—	—	0.7V	—	—
Q 115	0V	—	—	0.7V	—	—

MUTING SETTING LEVEL 10μV

FUNCTION

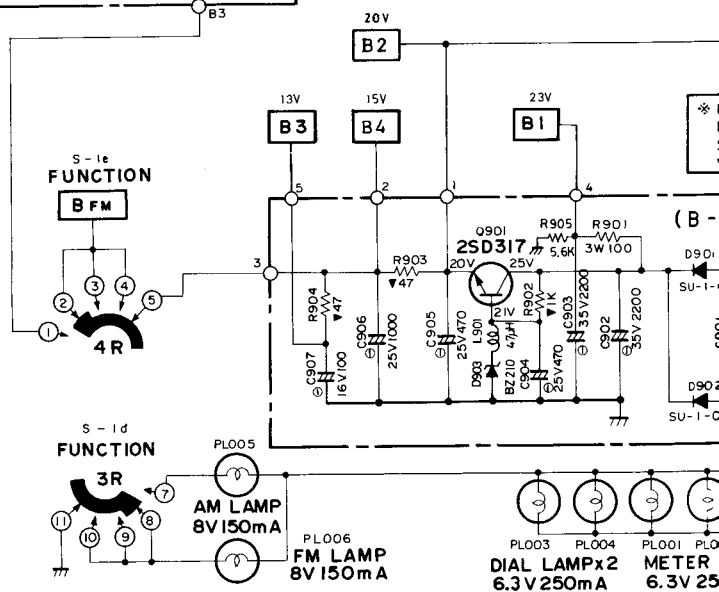

SCHEMATIC DIAGRAM RT824

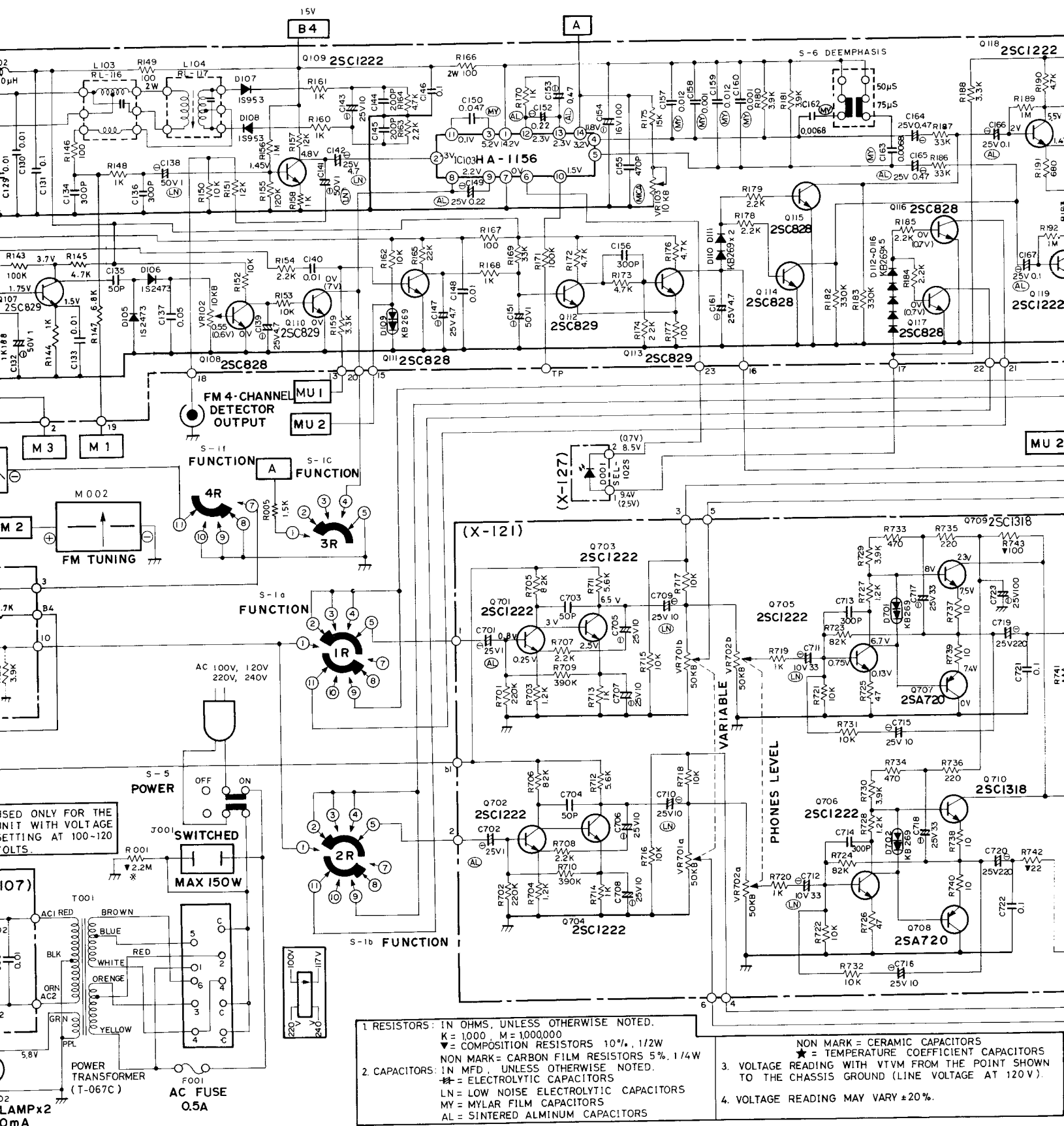

1. RESISTORS: IN OHMS, UNLESS OTHERWISE NOTED.
 K = 1000 M = 1000000
 ▼ = COMPOSITION RESISTORS 10%, 1/2W
 * = CARBON FILM RESISTORS 5%, 1/4W
2. CAPACITORS: IN MFD, UNLESS OTHERWISE NOTED.
 ✱ = ELECTROLYTIC CAPACITORS
 LN = LOW NOISE ELECTROLYTIC CAPACITORS
 MY = MYLAR FILM CAPACITORS
 AL = SINTERED ALUMINUM CAPACITORS

- NON MARK = CERAMIC CAPACITORS
 ✱ = TEMPERATURE COEFFICIENT CAPACITORS
3. VOLTAGE READING WITH VTVM FROM THE POINT SHOWN TO THE CHASSIS GROUND (LINE VOLTAGE AT 120V).
4. VOLTAGE READING MAY VARY ±20%.

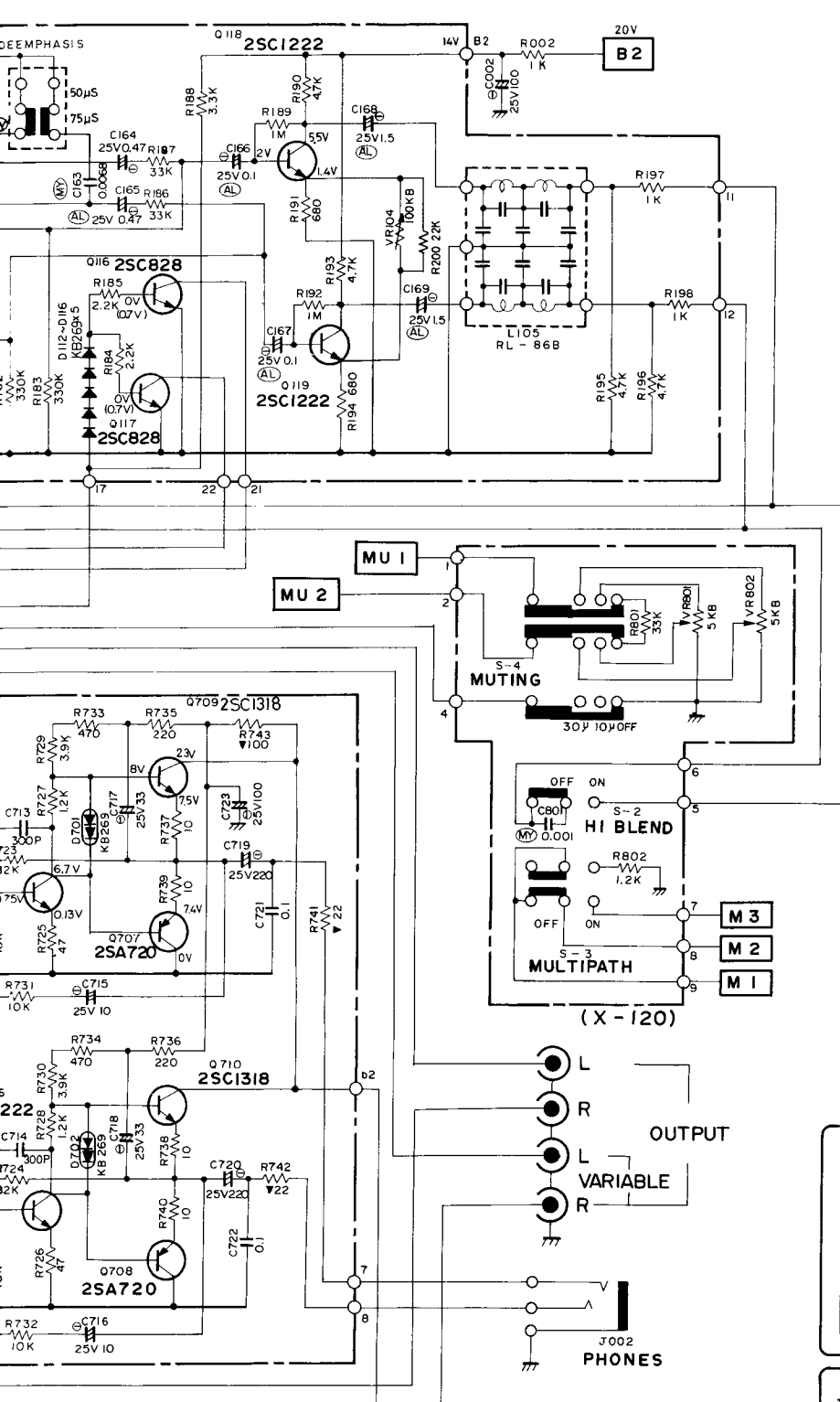

ITEM	SCHEMATIC LOCATION (LAST)
FM SECTION	R 200
	C 171
AM SECTION	R 222
	C 220
FM IF PREAMP.	R 304
	C 304
AUDIO AMP.	R 743
	C 723
CONTROL	R 802
	C 801
POWER SUPPLY	R 905
	C 907
	R 005
CHASSIS	R 004
	C 004

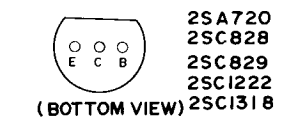
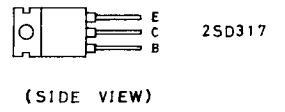
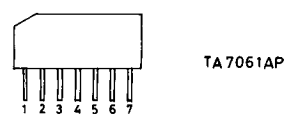
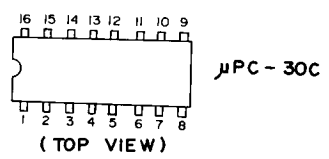
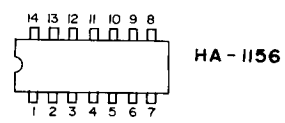

MK = CERAMIC CAPACITORS
 TEMPERATURE COEFFICIENT CAPACITORS
 WITH VTM FROM THE POINT SHOWN
 GROUND (LINE VOLTAGE AT 120V).
 MAY VARY ±20%.

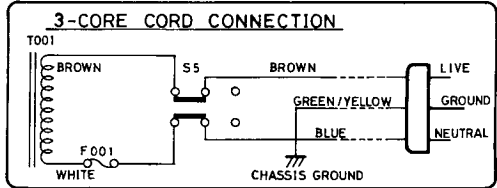
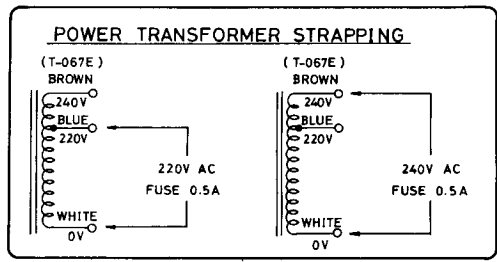

SCHEMATIC DIAGRAM RT624

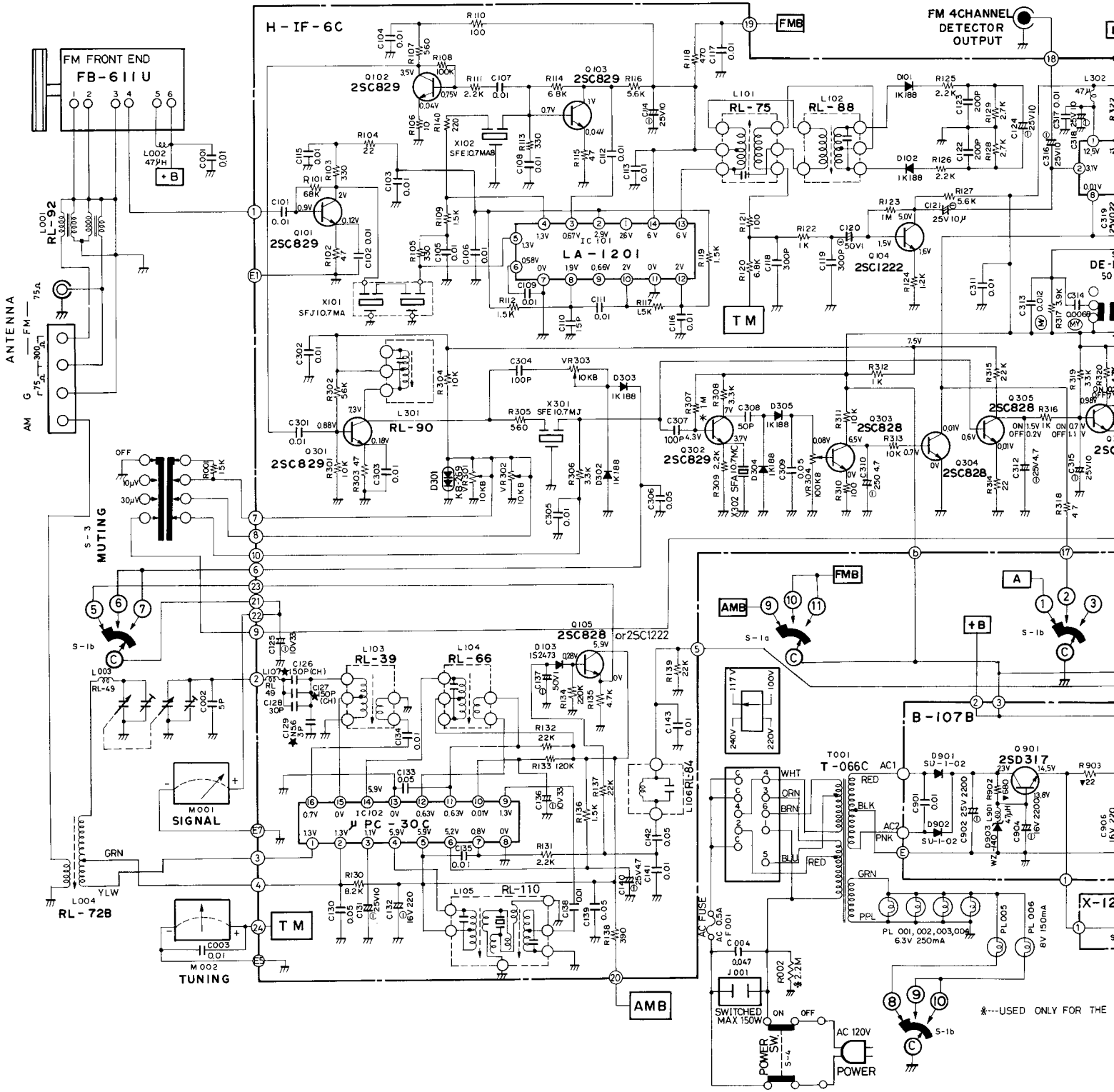

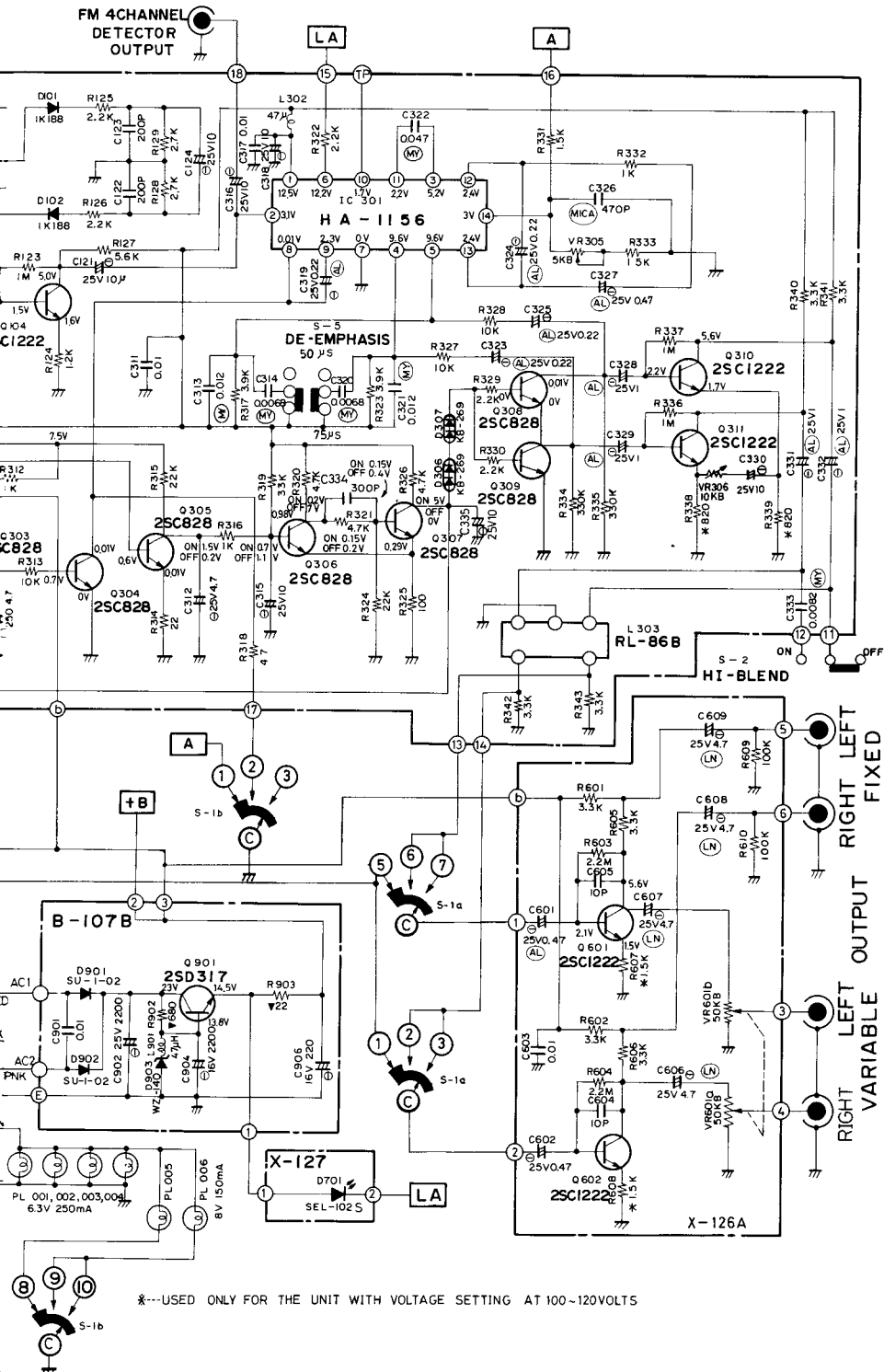

(RESISTORS)
 5% TOLERANCE UNLESS OTHERWISE NOTED
 K--- KILO OHM
 M--- MEGA OHM
 ▽--- COMPOSITION RESISTORS 1/2WATT
 NON MARK--- LOW NOISE TYPE CARBON RESISTORS 1/4WATT

(CAPACITORS)
 (MY)--- MYLAR FILM CAPACITORS
 (AL)--- SINTERED ALUMINUM SOLID ELECTROLYTIC CAPACITORS (ALSI CON)
 (LN)--- LOW NOISE TYPE CAPACITORS
 (E)--- ELECTROLYTIC CAPACITORS
 *--- TEMPERATURE COEFFICIENT CAPACITORS
 NON MARK--- CERAMIC CAPACITORS
 • UNLESS OTHERWISE NOTED IN SCHEMATIC ALL CAPACITANCE VALUES ARE EXPRESSED IN MFD.
 • VOLTAGE READING WITH VTVM FROM THE POINT SHOWN TO THE CHASSIS GROUND (LINE VOLTAGE 120 VOLT).
 • VOLTAGE READING MAY VARY ±20%. THESE VALUES MAY VARY DEPENDING UPON FACTORY ADJUSTMENT.

ITEM	SCHEMATIC LOCATION(LAST)	
AM FM IF AMP	R140	C143
FM MPX DECODER	R343	C335
MAIN AMP	R610	C609
POWER SUPPLY	R903	C906
CHASSIS	R002	C004

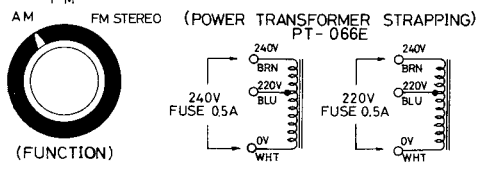
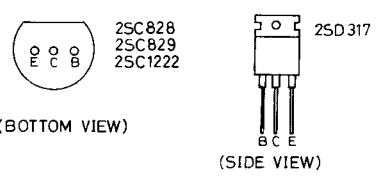
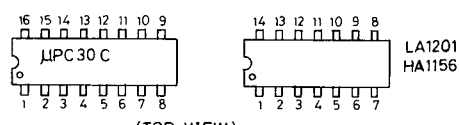

*---USED ONLY FOR THE UNIT WITH VOLTAGE SETTING AT 100-120VOLTS

RT624 AM / FM IF / MPX CIRCUIT BOARD DIAGRAM

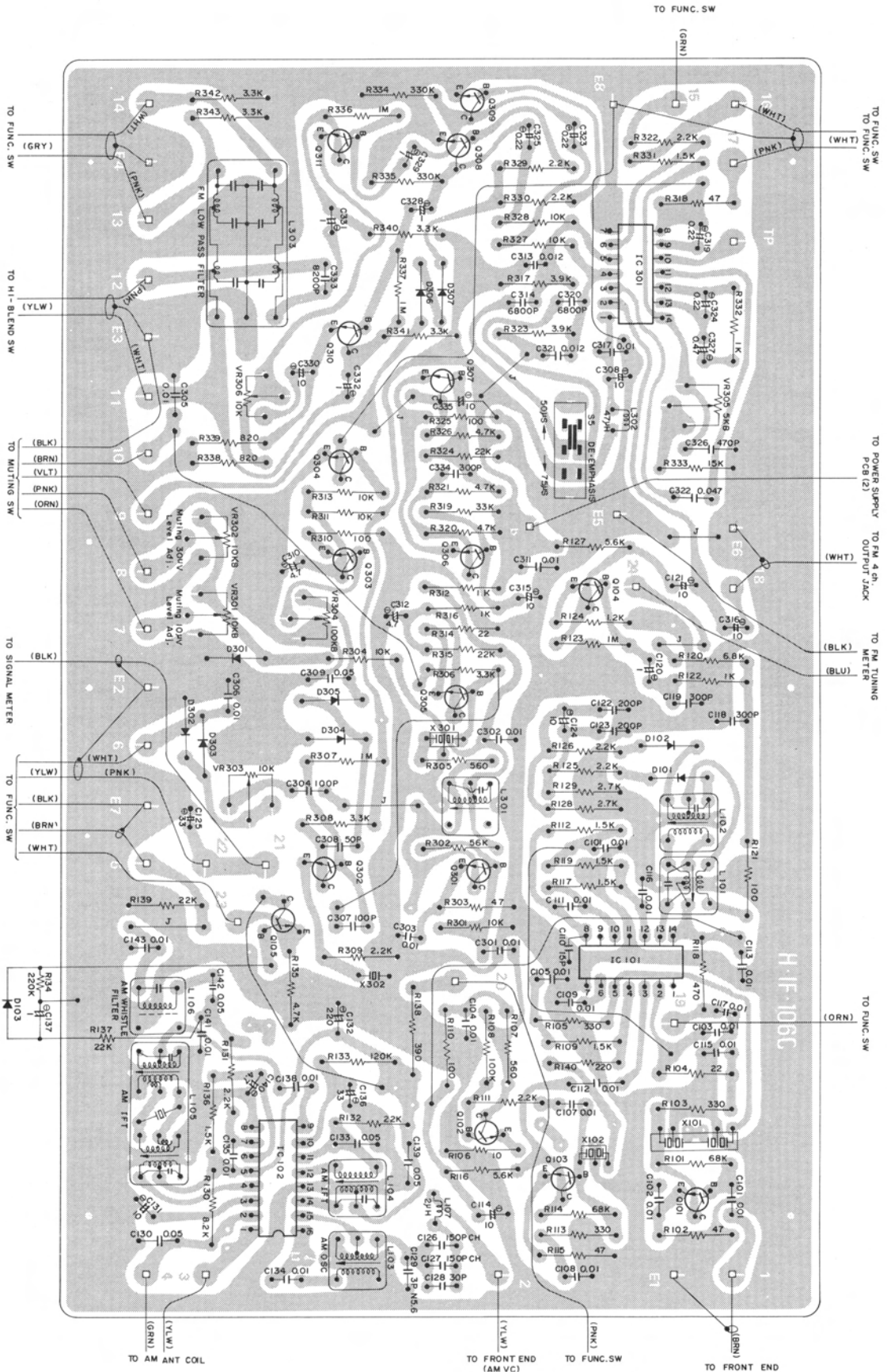

AUDIO AMP CIRCUIT BOARD DIAGRAM

RT-624

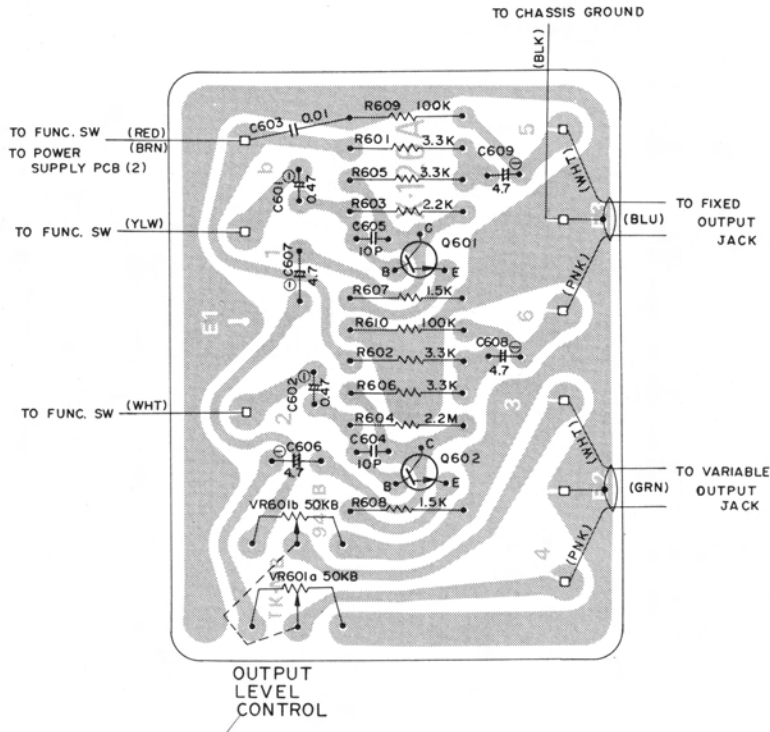

RT-824

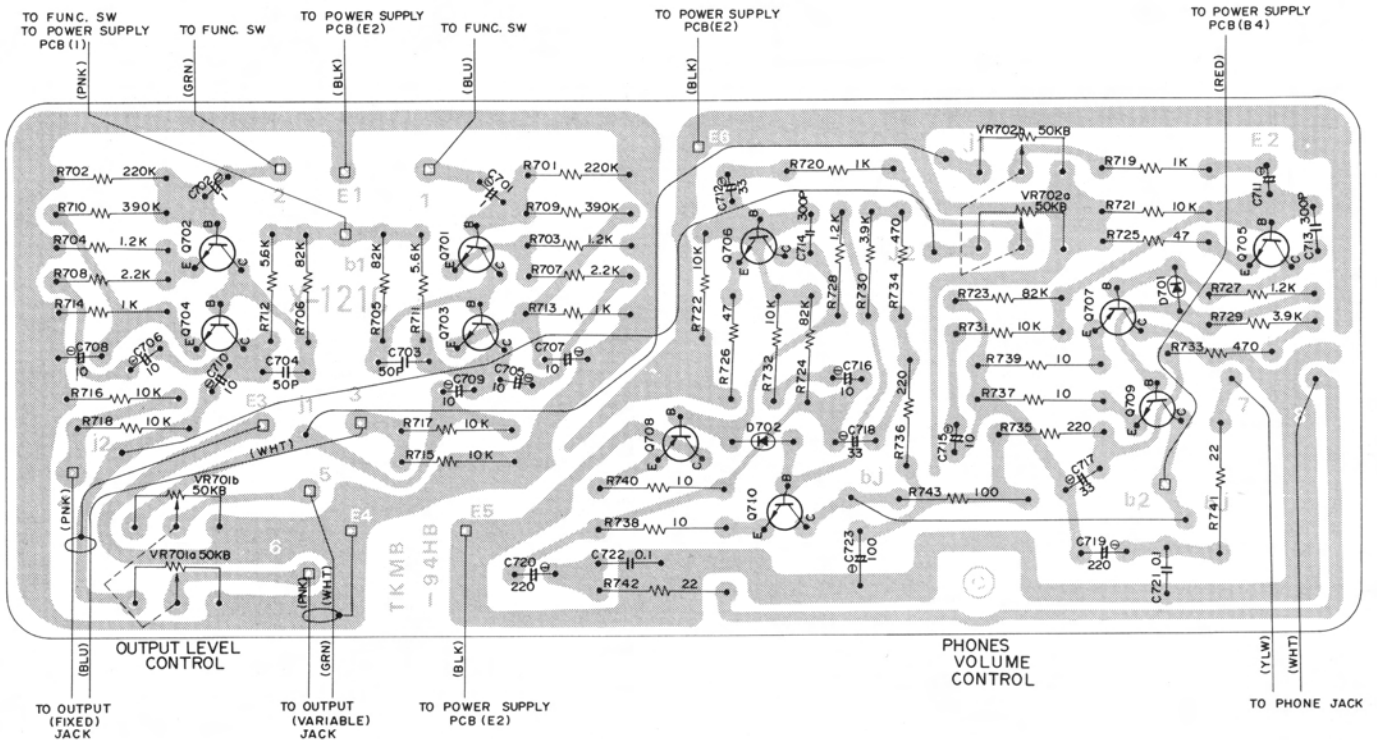

CONTROL CIRCUIT BOARD DIAGRAM (RT-824 ONLY)

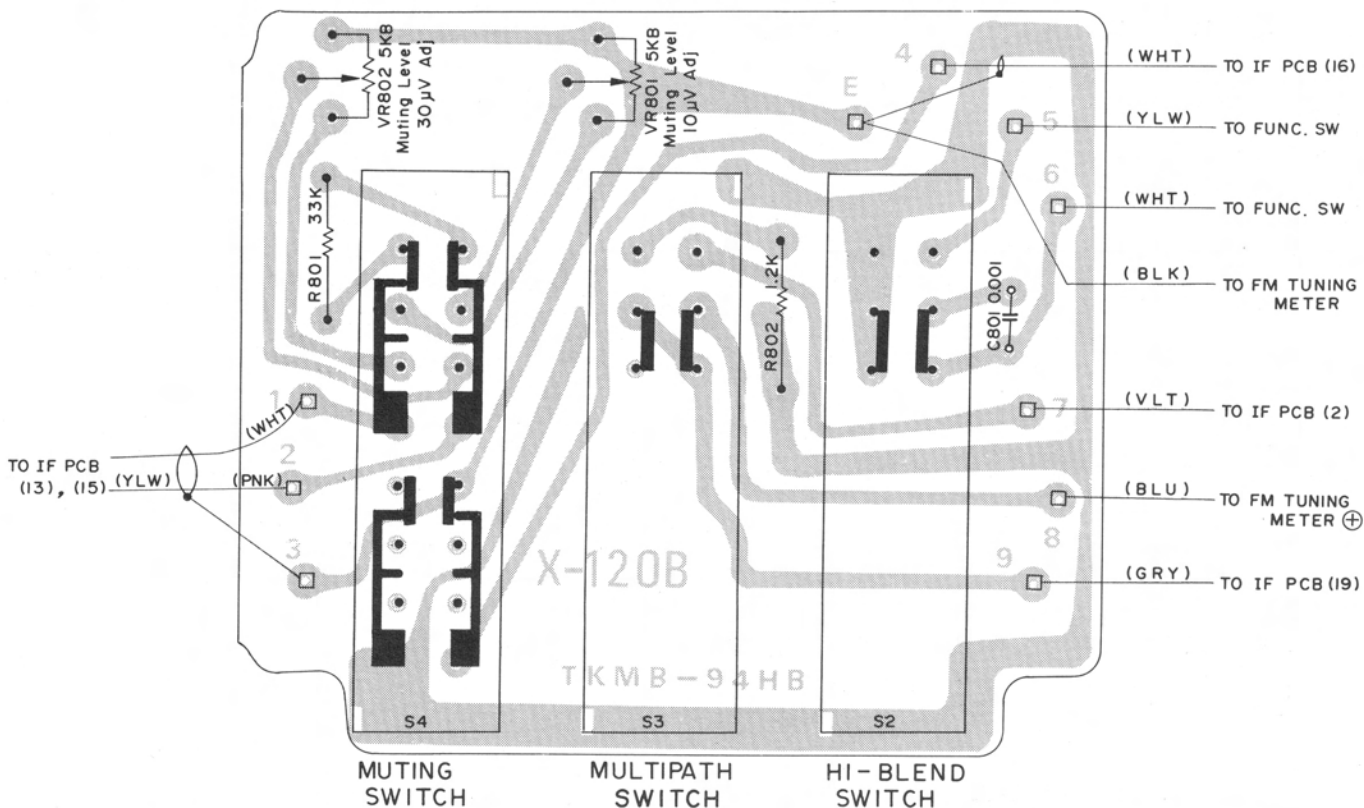

FM IF PREAMP CIRCUIT BOARD DIAGRAM (RT-824)

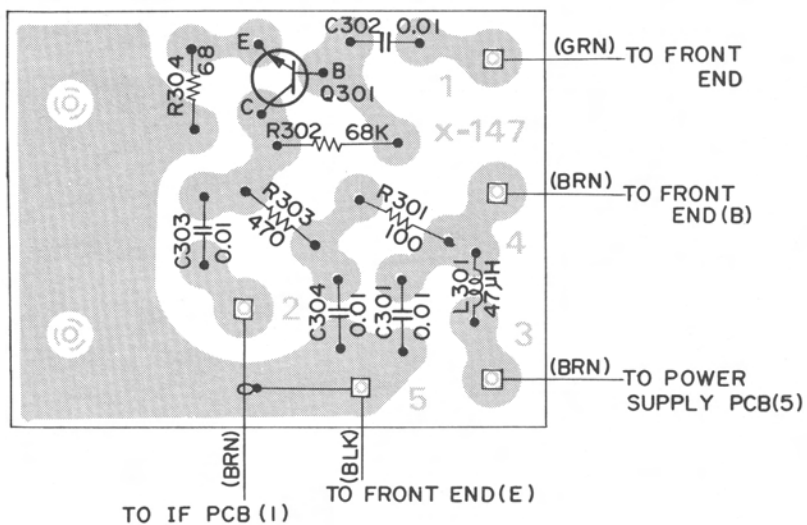

POWER SUPPLY CIRCUIT BOARD DIAGRAM (RT-624) (RT-824)

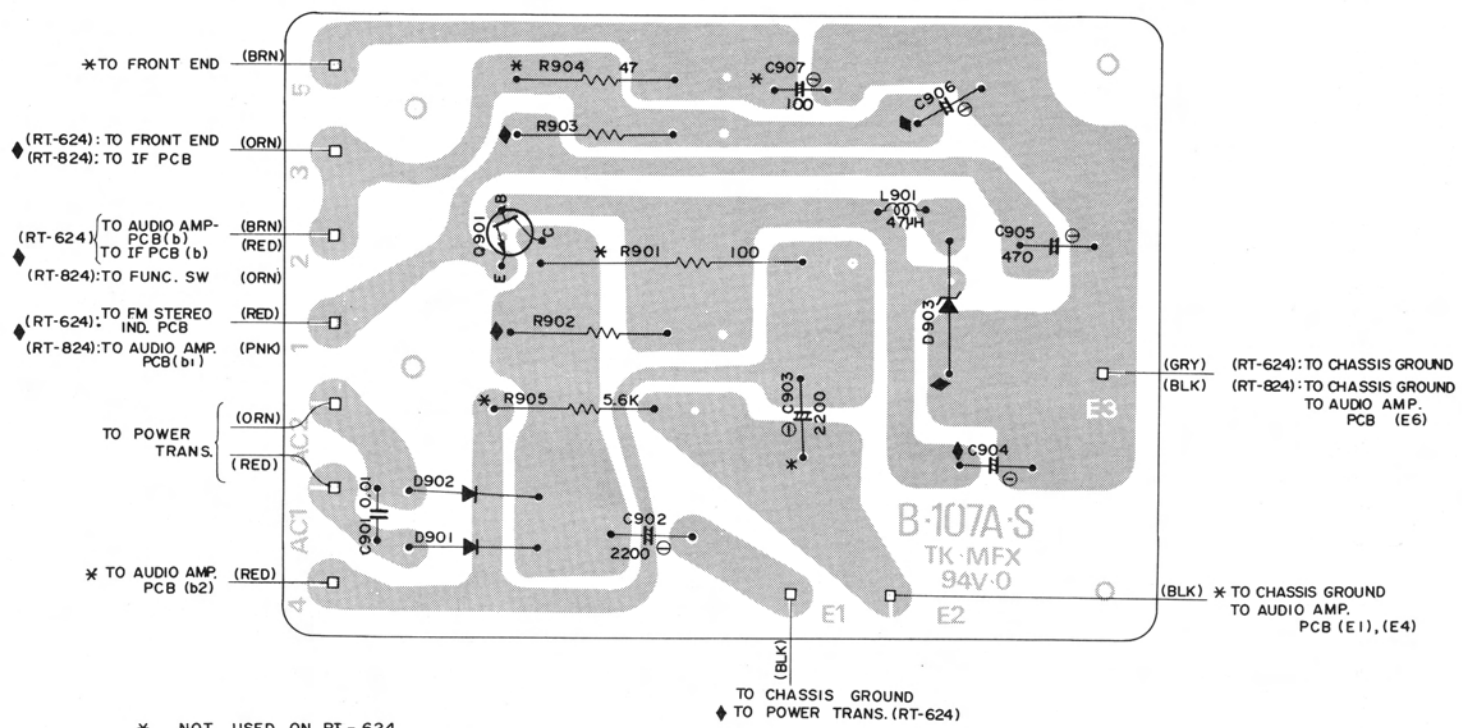

DIAL STRINGING DIAGRAM (RT-624) (RT-824)

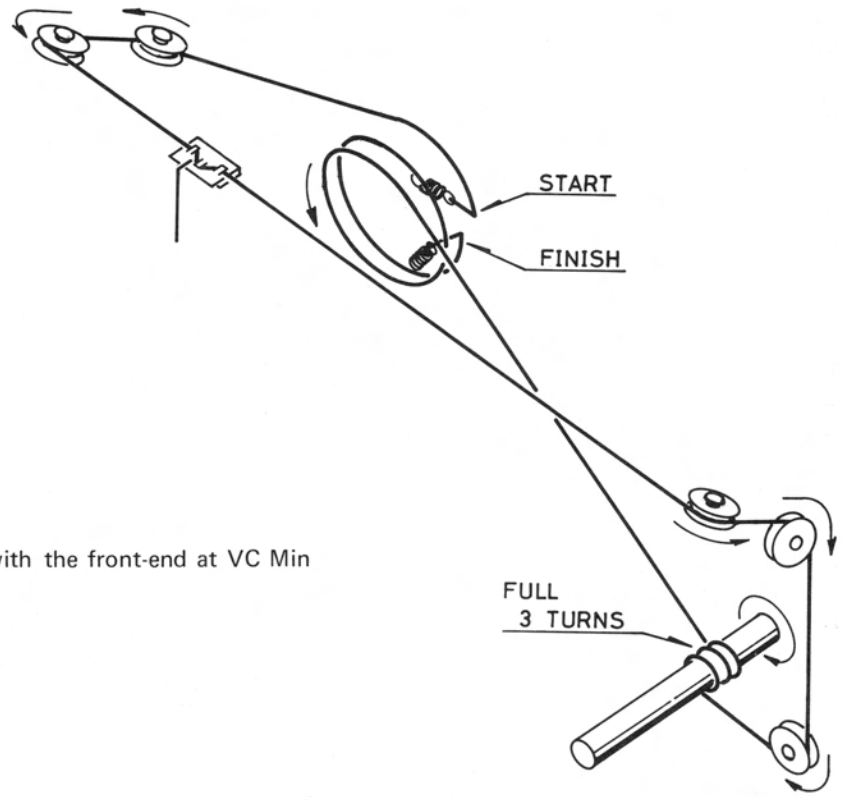

Note:
 1. Proceed dial stringing with the front-end at VC Min position.

REPAIR PARTS LIST RT-624

Schematic Location	Part No.	Description		
TRANSISTORS, DIODES and IC'S				
Q101,102 } Q103,301 } Q302 }	301201117	2SC829(C), FM IF Amp., FM Muting, etc.		
Q104,310 } Q311,601 } Q602 }			301201156	2SC1222(E), FM Composite Amp., Audio Amp., etc.
Q105,303 } Q304,305 } Q306,307 } Q308,309 }				
Q901,	301301125	2SD317, Stabilizer		
D101,102 } D302,303 } D304,305 }	300111008	1K188, FM Det., FM Meter Rect., etc..		
D103			300111010	1S2473, AM Meter Rect.
D301,306 } D307 }			300212004	KB-269, FM Muting Bias
D701	300414005	SEL-102S, FM Stereo Indicator		
D901,902	300919008	SM-1-02, Rectifier		
D903	300313018	WZ-140, Zener Regulator, 14V		
IC101	303452148	LA-1201, FM IF Amp.		
IC102	303452157	μ PC-30C, AM Conv. & AM IF Amp.		
IC301	303452151	HA-1156W, FM MPX Decoder		
COILS and TRANSFORMERS				
L101	225501125	FM IFT, Ratio (Pri.)		
L102	225501127	FM IFT, Ratio (Sec.)		
L103	223301124	AM OSC Coil		
L104	225301125	AM IFT, 1st		
L105	229101176	AM IFT, 2nd		
L106	228641119	AM Whistle Filter		
L107,003	226501124	RF Choke, 2 μ H		
L301	226501122	FM Muting Coil, 10.7 MHz Tune		
L302,901 } L002 }	226501123	RF Choke, 47 μ H (470)		
L303			228641118	FM Low Pass Filter
T001	205001391	Power Transformer (Multi-voltage)		
	204001391	Power Transformer (100V-120V)		
	206001391	Power Transformer (220V-240V)		
L001	226501121	FM Antenna Matching Transformer		
L004	222391122	AM Antenna Coil (Assembly)		

Schematic Location	Part No.	Description
VARIABLE RESISTORS		
VR301,302 } VR303,306 }	510502126	10KB, FM Muting Level Adj.
VR304		
VR305	510502128	5KB, FM Stereo Separation Adj.
VR601	525101128	50KBx2, Output Level Control
OTHERS		
X101	229101166	FM IF Bandpass Filter, 1st
X102	229101171	FM IF Bandpass Filter, 2nd
X301	229101139	FM IF Bandpass Filter
X302	229101177	Ceramic Resonator, 10.7MHz
M001	231310049	Meter, Signal AM/FM
M002	231310051	Meter, FM Tuning
	321304381	Front-end, AM/FM
S1	601011278	Switch, Function Selector
S2	611001632	Switch, Hi-Blend
S3	611001637	Switch, Muting
S4	614010118	Switch, Power
S5	613000024	Switch, De-emphasis
PL001,002 } PL003,004 }	352063025	Lamp, 6.3V, 0.25A, Dial Light
PL005,006		
	141311362	AM, FM and MPX Circuit Board Assembly
	141810617	Audio Amp. Circuit Board Assembly
	141810621	Power Supply Circuit Board Assembly

REPAIR PARTS LIST RT-824

Schematic Location	Part No.	Description
TRANSISTORS, DIODES and IC'S		
Q101,103	301201117	2SC829(C), FM IF Amp., FM Muting, etc.
Q104,105		
Q106,107		
Q110,112		
Q113		
Q102,108	301201115	2SC828(R), FM Muting, Multi-path, etc.
Q111,114		
Q115,116		
Q117		
Q109,118	301201156	2SC1222(E), FM Composite Amp., etc.
Q119,201		
Q701,702		
Q703,704		
Q705,706	301001139	2SA720, Audio Amp.
Q707,708		
Q709,710		
Q901	301301125	2SC317, Stabilizer
D101,104	300111008	1K188, FM Meter Rect., etc.
D201		
D102,103	300111010	1S2473, FM Stereo Auto-switching Rect.
D105,106		
D107,108	300111011	1S953, FM Det.
D109,110	300212004	KB-269, Varistor
D111,112		
D113,114		
D115,116		
D701,702	300919008	SM-1-02, Rectifier
D901,902		
D903		
D001	300414005	SEL-102S, FM Stereo Indicator
IC101,102	033452146	TA7061AP, FM IF Amp.
IC103	303452151	HA-1156W, FM MPX Decoder
IC201	303452157	μ PC-30C, AM Conv. and AM IF Amp.
COILS and TRANSFORMERS		
L101	226501122	FM Muting, 10.7 MHz Tune
L102	226501127	RF Choke, 470 μ H (471)
L103	225501129	FM IFT, Ratio (Pri.)
L104	225501130	FM IFT, Ratio (Sec.)
L105	228641118	FM Low Pass Filter
L201,202	226501124	RF Choke, 2 μ H
L203		
L204	223301131	AM OSC Coil
L205	226501112	AM RF Coil
L206	229101176	AM IFT
L207	228641119	AM Whistle Filter
L001	226501123	RF Choke, 47 μ H
L002	226501121	AM ANT Coil (Assembly)

Schematic Location	Part No.	Description
T001	205001397	Power Transformer (Multi-Voltage)
	204001397	Power Transformer (100V-120V)
	206001397	Power Transformer (220V-240V)
VARIABLE RESISTORS		
VR101,102	510502126	10KB, FM Signal Meter Level Adj., etc.
VR104		
VR103,801	510502128	5KB, FM MPX, 19kHz Adj., etc.
VR802		
VR201,202	510502130	100KB, AM Signal Meter Level Adj., etc.
VR701	525101128	50KBx2, Output Level Control
VR702	525101134	50KBx2, Phones Volume Control
OTHERS		
CT201,202	490110115	Capacitor, Trim., 24pF max, AM Tracking Adj.
CT203		
X101,102	229101171	FM IF Bandpass Filter
X104		
X103	229101166	FM IF Bandpass Filter
X105	229101139	FM IF Bandpass Filter
M001	231310049	Meter, Signal, AM/FM
M002	231310052	Meter, FM Tuning and Multi-path
	321304383	Front-end, AM/FM
S1	601011282	Switch, Function Selector
S2,3	611001632	Switch, Hi-Blend, Multi-path
S4	611001638	Switch, FM Muting
S5	614010118	Switch, Power
PL001,002	352063025	Lamp, 6.3V, 0.25A, Dial Light
PL003,004		
PL005,006	351080015	Lamp, 8V, 0.15A, AM, FM Indicator
	141311363	AM/FM/MPX Circuit Board Assembly
	141810622	Audio Amp. Circuit Board Assembly
	141810623	Control Circuit Board Assembly
	141810624	Power Supply Circuit Board Assembly
	141810636	FM IF Preamp Circuit Board Assembly