

Schaltbild · Schema · Circuit diagram · Schéma

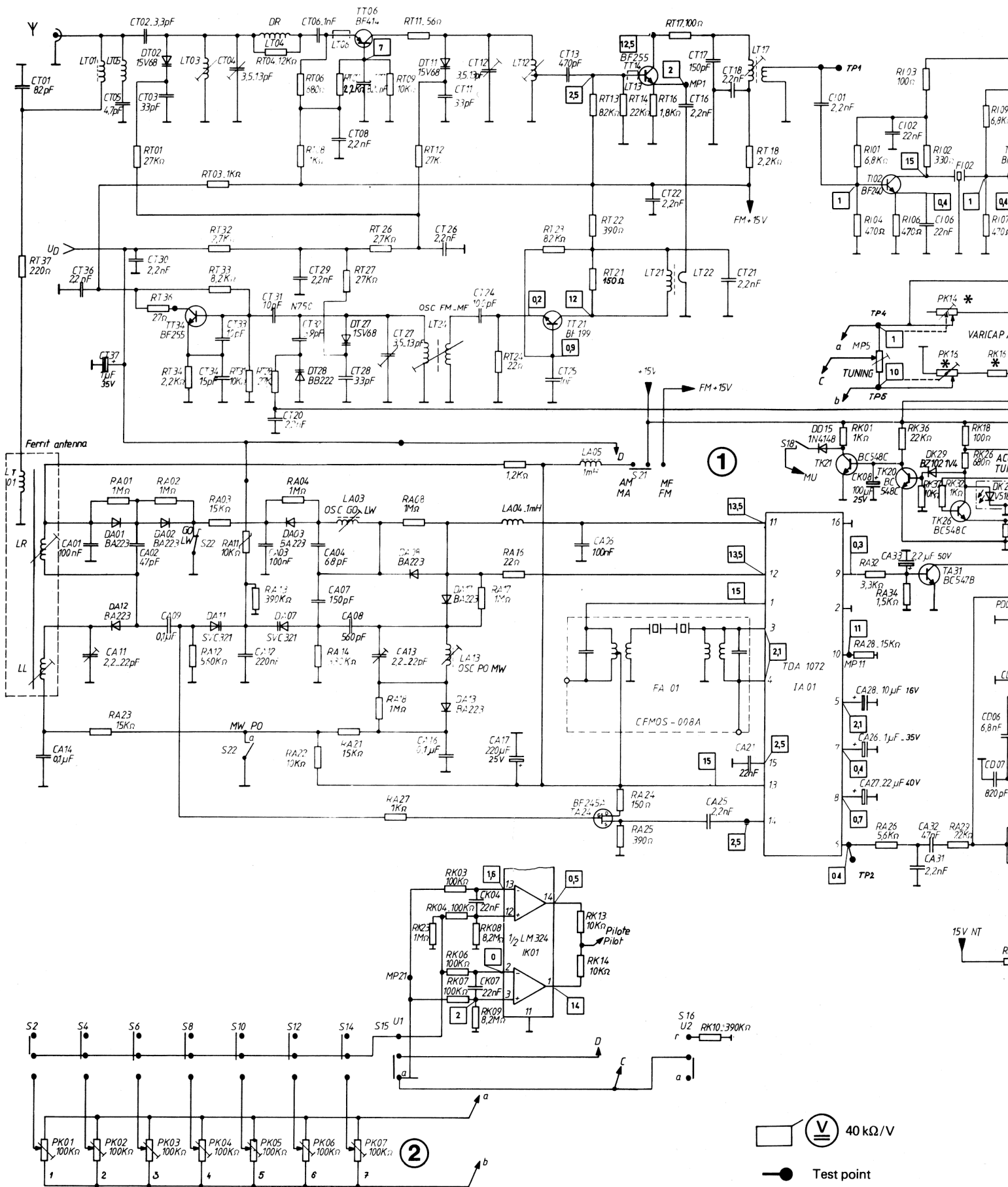

40 kΩ/V

Test point

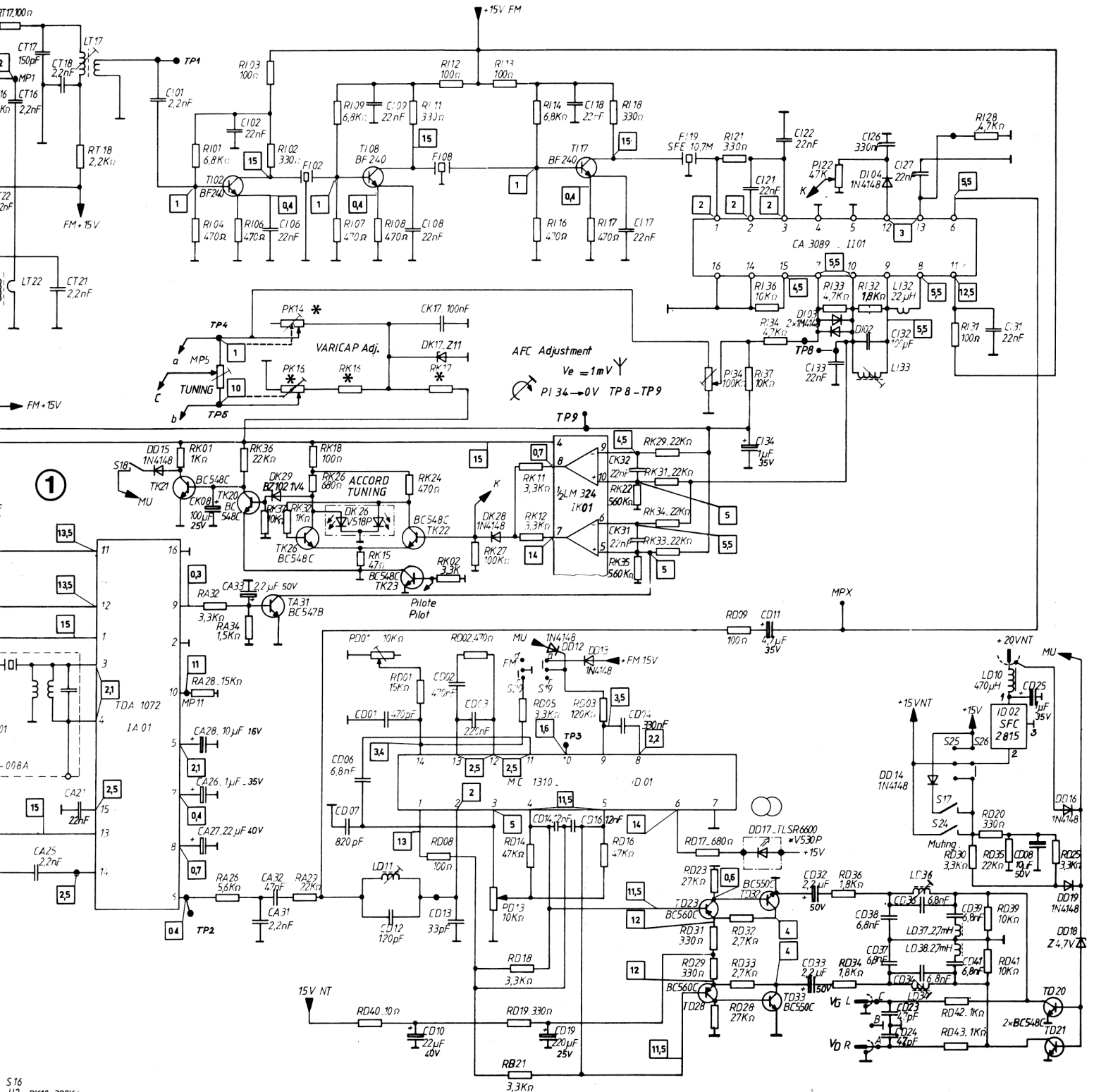

Modification

\*



● Test point

	1 Version	2 Version
PK 14 - PK 16	2,2 kΩ	220 Ω
RK 16	8,2 kΩ	560 Ω
RK 17	470 Ω	100 Ω

1

HF-ZF-Platte  
 Piastra AF-FI  
 HF-IF-board  
 Platine HF-FI

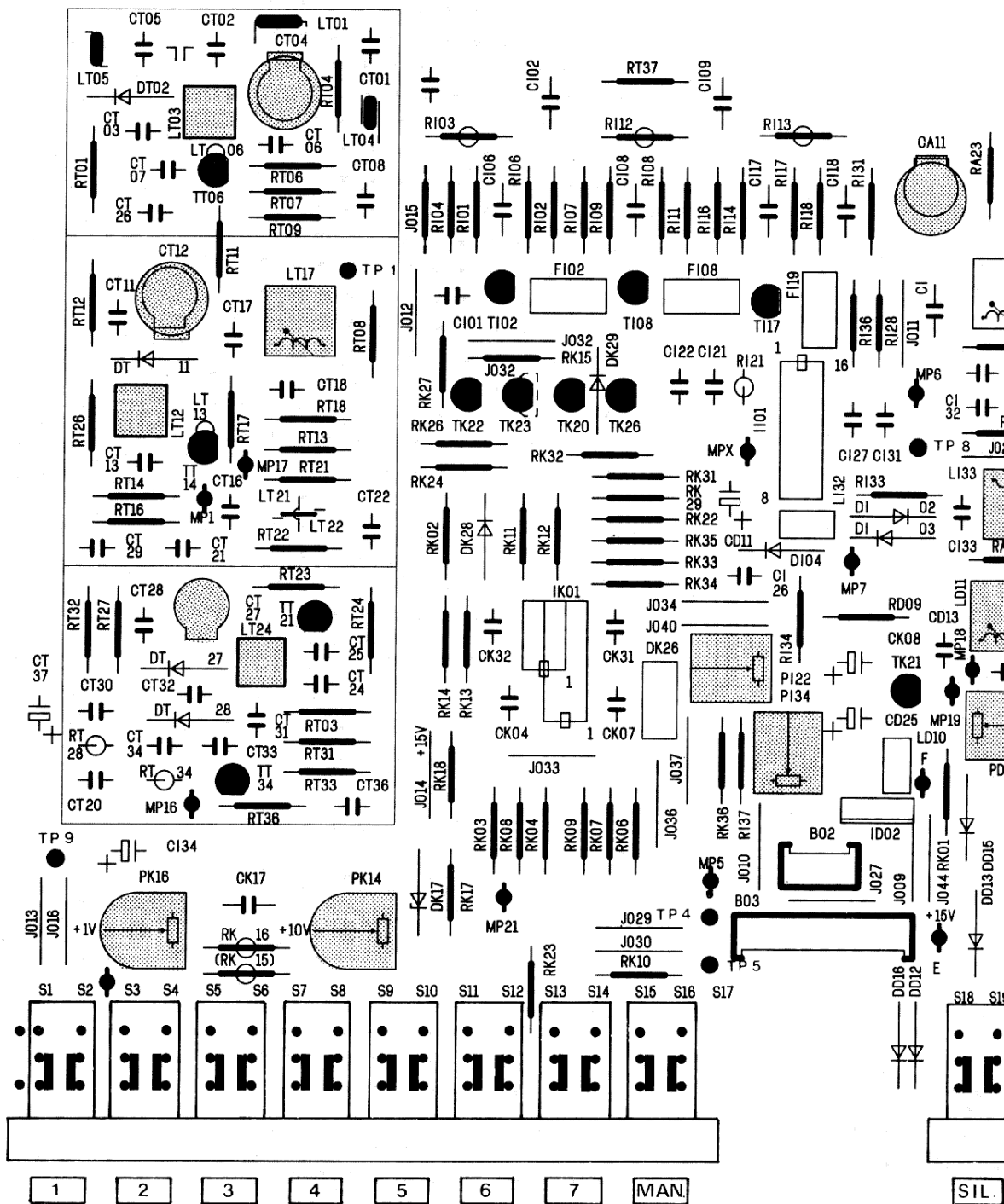

2



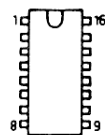
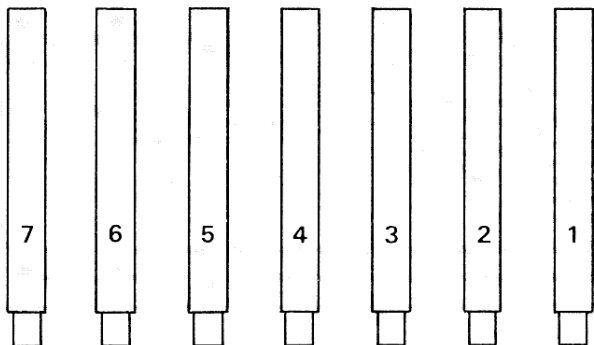





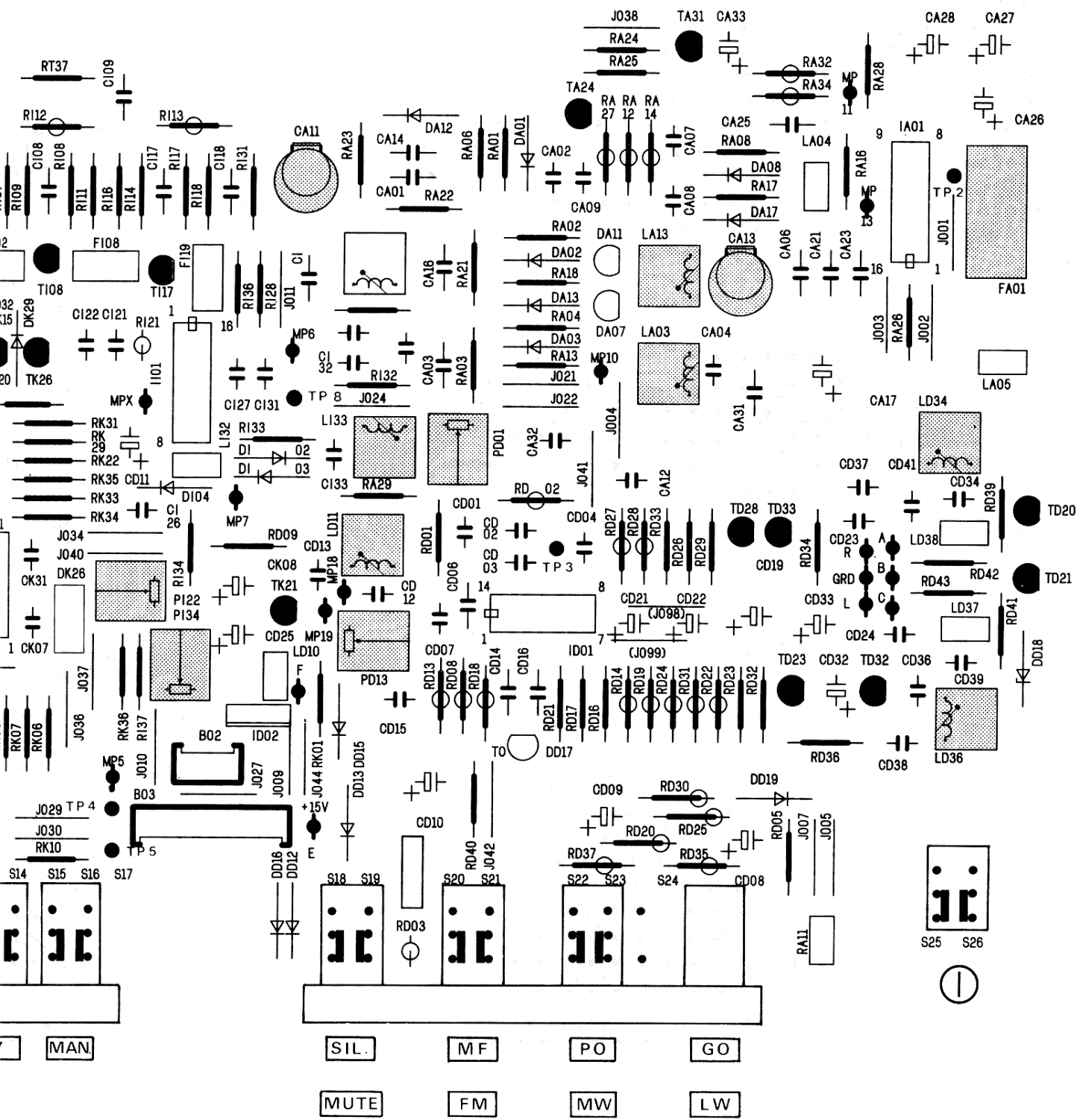

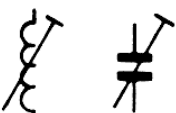

Stations-Einstellplatte  
 Piastra di preselezione  
 P. C. B. Pretuning  
 Platine présélection

















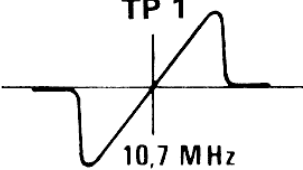



TCA 3089  
 TDA 1072

MUTE

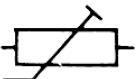

AM						
		 30% mod 1000 Hz	f			
IF FI ZF	1	14 IA 01	455 kHz		FA 01	TP 2 Max.
		$V_e \approx 100 \mu V$				
MW	2	Strap → TP 5	510 kHz		LA 13	TP 2 Max.
	3	$V_e \approx 100 \mu V$ Strap → TP 4	1630 kHz		CA 13	
PO	4	$V_e \approx 10 \mu V$	600 kHz	600 kHz 	LL	
	5		1500 kHz	 1500 kHz	CA 11	
LW GO	6	Strap → TP 5	145 kHz		LA 03	
		$V_e \approx 100 \mu V$				
	7	$V_e \approx 10 \mu V$	150 kHz	150 kHz 	LR	
						

FM						
		 30% mod 1000 Hz	f			
IF FI ZF	1		10,7 MHz		LT 17	TP 1  10,7 MHz
	2				LI 33	
FM MF	3	 $V_e \approx 1,5 \mu V$	87,5 MHz		LT 24	Max.
	4		108 MHz		CT 27	
	5		90 MHz	90 MHz 	LT 03 - LT 12	
	6		101 MHz	 101 MHz	CT 04 - CT 12	

Stereo Decoder, Décodeur stereo						
		 30% mod 1000 Hz	f			
	1	$V_e \approx 1 \text{ mV stereo}$	98 MHz	98 MHz 	PD 13	Minimum diaphonie
	2		98 MHz	98 MHz 	PD 01	TP 3 → 19 kHz

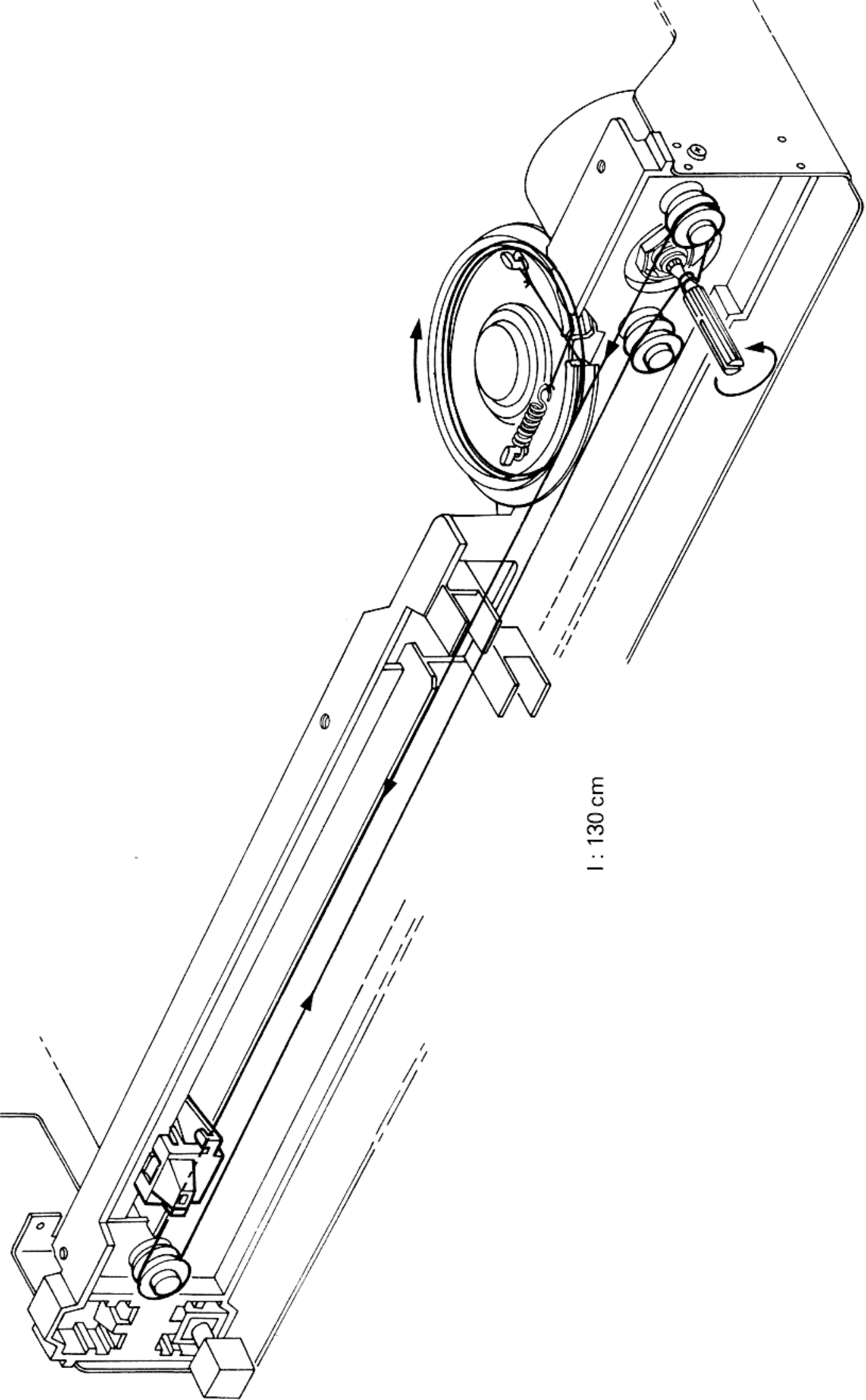

l : 130 cm