

SERVICE MANUAL

SOLID-STATE AM/FM STEREOPHONIC TUNER AMPLIFIER

SANSUI 2000



stereo 6V 100mA

Sansui®

SANSUI ELECTRIC COMPANY LIMITED

HOW TO USE THIS SERVICE MANUAL

1. Look up the type of trouble you are confronted with in either the General or Troubleshooting charts provided in this manual from pp 3-13.
2. By referring to the charts, isolate the trouble to a particular unit or part. (See the column titled "What to Do" in the General Chart and "Check Point" in the Troubleshooting Chart.)
3. Locate the section of the chassis (Parts Layout p. 23) in which the parts is located by using the co-ordinates (Column D) in the Parts List pp 31-37.
4. Using the co-ordinates given in the Parts List (Column C), pinpoint the position of the parts in the Schematic Diagram of Circuits, pp 19-20.

NOTE: Much of the information contained in this manual has been prepared for use by qualified service repairmen. Please read your Warranty thoroughly before attempting any internal adjustments on your own.

CONTENTS

GENERAL SECTION	3, 4
TROUBLESHOOTING CHART	
OVERALL PROGRAM SOURCES	5, 6, 7
FM OR FM-MPX RECEPTION	8, 9, 10
AM RECEPTION	10, 11
USING WITH RECORD PLAYER OR TAPE DECK	12, 13
OTHER PROGRAM SOURCES.....	13
RECORDING ON TAPE	13
ALIGNMENT POINTS AND PROCEDURE	14, 15, 16, 17, 18
SCHEMATIC DIAGRAM OF CIRCUITS	19, 20
DISASSEMBLY PROCEDURE	21
BLOCK DIAGRAM OF PRINTED CIRCUITS	22
PARTS LAYOUT	23
SELECTOR SWITCH CHART	24
PRINTED-CIRCUIT SHEETS	25, 26, 27, 28, 29, 30
PARTS LIST	31, 32, 33, 34, 35, 36, 37
COLOR CODE	38



SANSUI MODEL 2000

POWER

TAPE
REVERSE
REVERSE
REVERSE
REVERSE

Sansui Stereo Tuning Amplifier

POWER

1 1/2 HI-Z HONES SYSTEMS

SPEAKERS SYSTEMS SYSTEMS-1 OFF

LOW FILTER HIGH FILTER

BASS

TREBLE

BALANCE

VOLUME

SELECTOR

MICRO TAPE HEAD AM FM AUTO FM MANUAL AUX

GENERAL SECTION

If the amplifier is otherwise operating satisfactorily, the more common causes of trouble may generally be attributed to the following:

1. Incorrect connections or loose terminal contacts. Check the speakers, record player, tape recorder, antenna and line cord.
2. Improper operation. Before operating any audio component, be sure to read the manufacturer's in-

structions.

3. Improper location of audio components. The proper positioning of components, such as speakers and turntable, is vital to stereo.
4. Defective audio components.

Following are some other common causes of malfunction and what to do about them:

PROGRAM	SYMPTOM	PROBABLE CAUSE	WHAT TO DO
AM, FM or MPX reception	A. Constant or intermittent noise heard at certain times or in a certain area.	<ul style="list-style-type: none"> * Discharge or oscillation caused by electrical appliances, such as fluorescent lamps, TV sets, D.C. motors, rectifier and oscillator * Natural phenomena, such as atmospheric static, and thunderstorms. * Insufficient antenna input due to reinforced concrete walls or long distance from the station * Wave interference from other electrical appliances 	<ul style="list-style-type: none"> * Attach a noise limiter to the electrical appliance that causes the noise, or attach it to the power source of the amplifier. * Install an outdoor antenna and ground the amplifier to raise the signal-to-noise ratio. * Reverse the power cord plug-receptacle connections. * If the noise occurs at a certain frequency, attach a wave trap to the ANT. input * Place the set away from other electrical appliances.
	B. Needle of the tuning meter does not move sharply.	<ul style="list-style-type: none"> * Needle movement is not necessarily related to the sensitivity of the amplifier. 	<ul style="list-style-type: none"> * Tune the set for maximum signal strength.
	C. Zero point of the meter moves greatly.	<ul style="list-style-type: none"> * Regional difference in field intensity. 	<ul style="list-style-type: none"> * The unit is not at fault.
AM reception	A. Noise heard at a particular time of day, in a certain area or over part of the dial.	<ul style="list-style-type: none"> * Natural AM reception phenomenon. 	<ul style="list-style-type: none"> * Install an antenna for maximum antenna efficiency. See "ANTENNA" in the Operating Instructions. * In some cases, the noise can be eliminated by grounding the amplifier or reversing the power cord plug-receptacle connections.
	B. High-frequency noise	<ul style="list-style-type: none"> * Adjacent-channel interference or beat interference * TV set is too close to the audio system 	<ul style="list-style-type: none"> * Although such noise cannot be eliminated by the amplifier, it is advisable to turn the TREBLE control from midpoint to left and switch on the HIGH FILTER. * Place the TV set away from the audio system.
FM reception	A. Noisy	<ul style="list-style-type: none"> * Poor noise limiter effect or too low S/N ratio due to insufficient antenna input. 	<ul style="list-style-type: none"> * Adjust the antenna provided for maximum signal strength. * If this is not effective, use an outdoor antenna designed exclusively for FM. When you use a TV antenna for both TV and FM with a divider, make sure TV reception is not affected. * An excessively long antenna may cause noise.
	<p>NOTE: FM reception is affected considerably by the conditions of the transmitting stations power and antenna efficiency. As a result, you may receive one station quite well while having difficulty receiving another station.</p>		

PROGRAM	SYMPTOM	PROBABLE CAUSE	WHAT TO DO
FM reception (Cont'd)	B. "Scratch-like" noise is heard.	* Ignition noise caused by the starting of an automobile.	* Install the antenna and its lead-in wire away from the road or raise the antenna input as previously described.
	D. Tuning noise between stations	* This noise results from the nature of FM reception. As the station signal becomes weak, the noise limiter effect is decreased. The amplification of the limiter, in turn, is enlarged and a noise is generated.	* Turn on the MUTING switch. Since it also reduces the sensitivity, it should be used sparingly.
FM-MPX reception	A. Noise heard during FM-MPX reception while not heard during FM mono reception.	* The service area of the FM-MPX broadcast is only half that of the FM mono broadcast.	* Install the antenna for maximum antenna input. * Switch on the HIGH FILTER and/or turn the TREBLE control from midpoint to left.
	B. Clearness of channel separation is decreased during reception.	* Excess heat	* Make sure that air can flow underneath the amplifier.
	C. The stereo indicator goes on and off.	* Interference	* The indicator is not at fault. * Readjust VR ₆₀₁ .
	D. The stereo indicator goes on and off even though a stereo station is not received.	* Interference	* The indicator is not at fault. * Readjust VR ₆₀₁ .
Record playing or tape playback	A. Hum or howling	* Record player placed directly on the speaker box. * Use of unshielded wire. * Loose terminal contact. * Shielded wire too close to line cord, fluorescent lamp or other electrical appliances. * Nearby amateur radio station or TV transmission antenna.	* Put a cushion between the player and the speaker box or separate them. * The connecting shield wire should be as short as possible. * Switch on the LOW FILTER and turn the BASS control from midpoint to left. * Consult the nearest Radio Regulatory Bureau.
	B. Surface noise	* Worn or old record * Worn pick-up needle * Dusty needle. * Improper needle pressure	* Recondition the playback head of the tape recorder or the pick-up of the record player. * Turn the TREBLE control properly from midpoint to left. * Switch on the HIGH FILTER.
Overall stereo programs	The BALANCE control is not at midpoint when equal sound comes from left and right channels.	* It is important to adjust the control for equal sound from both channels. It should not always be set to midpoint.	* Set the MODE switch to the MONO position and then set the BALANCE control to the position where equal sound comes from both channels.

TROUBLESHOOTING CHART

OVERALL PROGRAM SOURCES

SYMPTOM	PROBABLE CAUSE	CHECK POINT	
No sound— overall program sources	A. Defective speaker system	1. Speaker cord or network broken or shorted 2. Broken or short-circuited voice coil	Check continuity of speaker and cord. Repair broken cord or replace speaker.
	B. No power	1. No power comes to the power source. 2. Defective on-off switch 3. Defective line cord 4. Loose plug contact 5. Blown fuse If the fuse burns out as soon as it is replaced, the trouble may be attributed to: a. Shorted power transformer b. Shorted capacitor c. Shorted power transistor NOTE: Check the continuity between the collector and emitter of the power transistor. If it is 0 ohm or close to 0 ohm, the transistor is defective. If it is more than 20 ohms, the transistor is O.K. See Fig. page 7. d. B circuit open.	S ₀₀₁ PU ₀₀₁ F ₀₀₁ T ₀₀₁ C ₀₀₂ , C ₀₀₄ , C ₀₀₅ TR ₈₀₅ , TR ₈₀₆ , TR ₈₁₁ , TR ₈₁₂
	C. Defective power circuit	Divergence from voltage specified in "SCHEMATIC DIAGRAM"	Measure voltage in power circuit and replace defective element.
	D. Defective low-frequency circuit	1. Protector lamp is on. 2. Blown fuse If the fuse burns out as soon as it is replaced, the trouble may be attributed to: a. Defective or shorted power transistor b. Contact at output terminal 3. Divergence of voltage specified in "SCHEMATIC DIAGRAM" 4. Defective transistor 5. Capacitor, shorted or open	Push the power switch off, after 5 or 6 seconds, push it on. F ₈₀₁ , F ₈₀₂ TR ₈₀₃ ~TR ₈₀₆ , TR ₈₀₉ ~TR ₈₁₂ Check the speaker system also. Measure voltage in low-frequency circuit and replace defective element.
	E. Non-electrical trouble	1. TAPE MONITOR switch is in ON position. 2. SPEAKER switch is in OFF position.	Turn it off. Turn it to SYSTEM A or SYSTEM B.

SYMPTOM	PROBABLE CAUSE		CHECK POINT
Weak sound—overall program sources	A. Defective speaker circuit	Shorted voice coil	Check voice coil for short circuit
	B. Defective power circuit	Divergence of voltage specified in "SCHEMATIC DIAGRAM"	Measure voltage in power circuit and replace defective element.
	C. Defective low-frequency circuit	1. Divergence of voltage 2. Insufficient capacity or short circuit of capacitor 3. Weak transistor	Measure voltage in low-frequency circuit and replace defective element. C ₇₀₁ , C ₇₀₅ , C ₇₀₆ , C ₇₁₀ , C ₇₁₂ , C ₇₁₃ , C ₇₁₄ , C ₇₁₈ , C ₇₁₉ , C ₇₂₄ , C ₇₂₆ , C ₈₀₁ , C ₈₀₃ , C ₈₀₄ , C ₈₁₁ , C ₈₁₂ , C ₈₁₄ , C ₈₁₅ , C ₈₁₈ TR ₇₀₁ ~TR ₇₀₄ , TR ₈₀₁ ~TR ₈₁₀ , TR ₈₀₅ ~TR ₈₁₂
Distortion—overall program sources	A. Defective speaker	1. Defective voice coil 2. Defective cone or damper	Check and replace.
	B. Defective power circuit	Divergence of voltage specified in "SCHEMATIC DIAGRAM"	Measure voltage in power circuit and replace defective element.
	C. Defective low-frequency circuit	1. Divergence of voltage specified in "SCHEMATIC DIAGRAM" 2. Aging or weak transistor 3. Quick acting fuse blown	Measure voltage in low-frequency circuit and replace defective element. TR ₇₀₁ ~TR ₇₀₄ , TR ₈₀₁ ~TR ₈₁₀ TR ₈₀₅ ~TR ₈₁₂ F ₈₀₁ ~F ₈₀₂
Hum—overall program sources	A. Defective power circuit	1. Insufficient capacity of capacitor 2. Ripple filter transistor defective	C ₀₀₄ , C ₀₀₅ TR ₀₀₁
	B. Defective low-frequency circuit	1. Insufficient capacity of capacitor 2. Fixed resistor blown	C ₀₀₈ , C ₇₀₂ , C ₇₁₅ , C ₈₁₀ , C ₈₂₁ R ₈₀₉ , R ₈₁₇ , R ₈₁₉ , R ₈₂₀
Noisy—overall program sources	A. Defective speaker	1. Defective voice coil 2. Inner contact of speaker components 3. Defective cone or damper	Check speaker system
	B. Defective power circuit	Divergence of voltage specified in "SCHEMATIC DIAGRAM"	Measure voltage in power circuit and replace defective element.
	C. Defective low-frequency circuit	1. Poor transistor 2. Master volume defective	TR ₇₀₁ ~TR ₇₀₄ , TR ₈₀₁ ~TR ₈₀₄ , TR ₈₀₅ ~TR ₈₁₂ VR ₇₀₂ , VR ₇₀₆
SPEAKER switch does not work	A. Defective headphone		Check headphone.
	B. Defective headphone circuit		S _{9a} , S _{9b} , S _{9c} , S _{9d} , R ₈₄₃ , R ₈₄₆

TROUBLESHOOTING CHART

OVERALL PROGRAM SOURCES (CONT'D)

SYMPTOM	PROBABLE CAUSE	CHECK POINT
HIGH FILTER switch does not work.	Defective filter circuit	C ₇₂₉ , C ₇₃₃ , S _{7a} , S _{7b}
LOW FILTER switch does not work.	Defective filter circuit	C ₇₃₀ , C ₇₃₄ , R ₇₄₁ , R ₇₄₆ , S _{8a} , S _{8b}
LOUDNESS switch does not work.	Defective filter circuit	C ₇₂₇ , C ₇₂₈ , C ₇₃₁ , C ₇₃₂ , R ₇₃₇ , R ₇₄₂ , VR ₇₀₂ , VR ₇₀₆ , S _{6a} , S _{6b}
TONE CONTROL does not work.	Defective tone control circuit	C ₇₀₇ , C ₇₀₈ , C ₇₀₉ , C ₇₂₀ , C ₇₂₁ , C ₇₂₂ , R ₇₁₀ , R ₇₁₁ , R ₇₁₃ , R ₇₁₄ , R ₇₂₈ , R ₇₂₉ , R ₇₃₀ , R ₇₃₁ , R ₇₃₂ , VR ₇₀₃ , VR ₇₀₄ , VR ₇₀₇ , VR ₇₀₈

Fig. HOW TO CHECK TR₈₀₅, TR₈₀₆, TR₈₁₁ AND TR₈₁₂

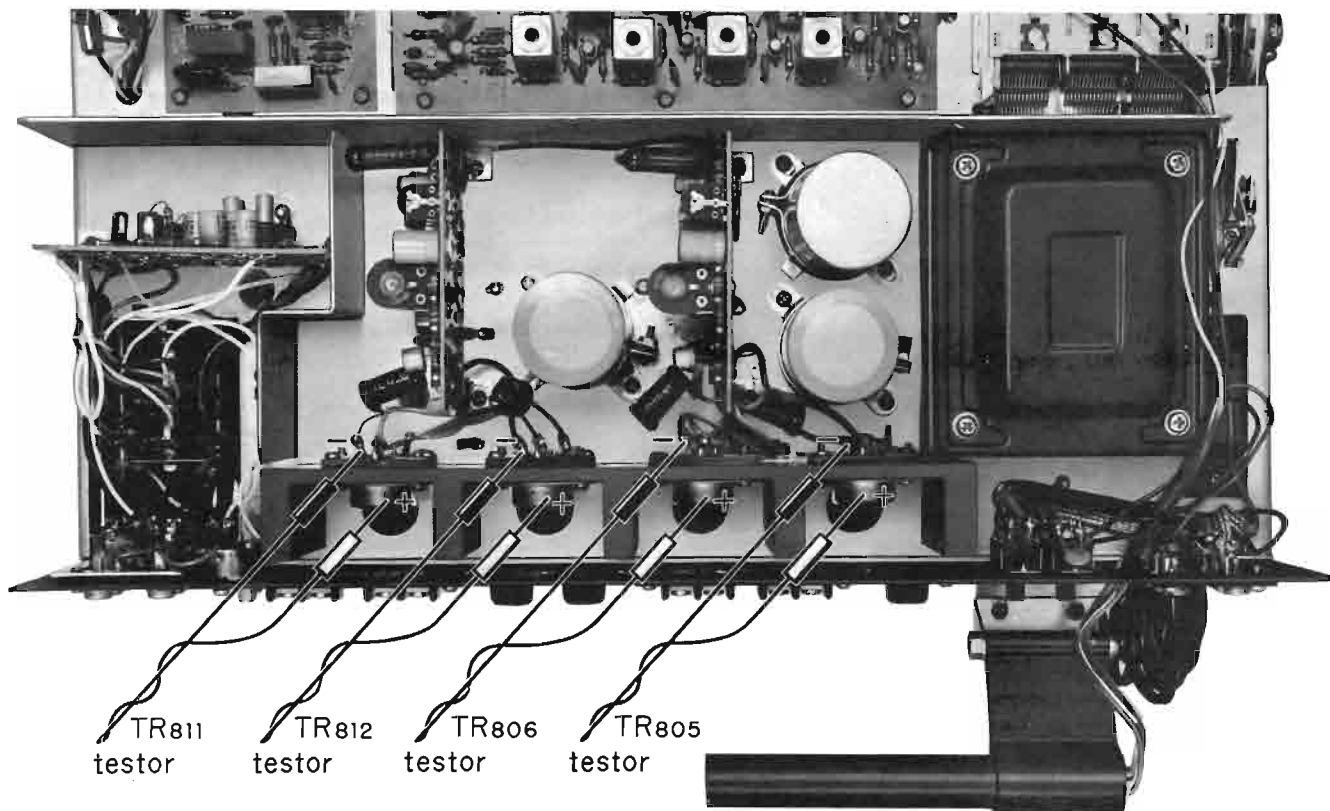

FM OR FM-MPX RECEPTION

SYMPTOM	PROBABLE CAUSE	CHECK POINT
No sound	A. Defective overall section	See "No sound—overall program sources".
	B. Defective FM or FM-MPX section <ol style="list-style-type: none"> 1. Divergence of voltage specified in "SCHEMATIC DIAGRAM" 2. Aging or weak transistor 3. Defective resistor 4. Aging capacitor 5. Aging defective IFT 6. Defective coil 7. Aging or defective CR 8. Defective oscillator circuit 	Measure voltage in FM or FM-MPX section and replace defective element. TR ₁₀₁ ~TR ₁₀₃ , TR ₂₀₁ ~TR ₂₀₅ , TR ₄₀₁ ~TR ₄₀₃ , FET ₁₀₁ R ₁₁₅ , R ₂₀₉ , R ₂₁₄ , R ₂₁₉ , R ₂₂₃ C ₁₀₁ , C ₁₀₇ , C ₁₁₃ , C ₁₁₉ , C ₁₂₄ , C ₁₂₅ , C ₄₀₁ , C ₄₀₂ , C ₄₀₃ , C ₄₀₆ , C ₄₁₁ , C ₄₁₂ T ₂₀₁ ~T ₂₀₅ , L ₁₀₄ L ₁₀₁ ~L ₁₀₅ , L ₄₀₁ , T ₄₀₁ CR ₄₀₁ , CR ₄₀₂ TR ₁₀₃ , C ₁₁₄ , C ₁₁₉ , C ₁₂₀ , C ₁₂₄ VR ₂₀₁
Weak sound	A. Weak station signal	See "General Section"
	B. Defective overall section	See "Weak sound—overall program sources".
	C. Defective FM or FM-MPX section <ol style="list-style-type: none"> 1. Divergence of voltage specified in "SCHEMATIC DIAGRAM" 2. Poor Q or divergence of adjustment of coil 3. Insufficient capacity of capacitor 4. Improper contact of rotary switch 5. Aging or weak transistor 6. Aging diode 7. Voltage drop in local oscillator 8. Defective AGC circuit 9. Divergence in adjustment of: <ol style="list-style-type: none"> a. Tracking b. I.F.T. c. MPX coil 	Measure voltage in FM or FM-MPX section and replace defective element. L ₁₀₁ ~L ₁₀₅ , T ₂₀₁ ~T ₂₀₅ , T ₄₀₁ ~T ₄₀₅ C ₂₀₁ , C ₂₀₂ , C ₂₀₃ , C ₂₀₄ , C ₂₀₆ , C ₂₀₇ , C ₂₁₀ , C ₂₁₃ , C ₂₁₅ , C ₂₁₆ , C ₄₀₁ ~C ₄₁₁ S _{1e} , S _{1f} , S _{1h} TR ₁₀₁ ~TR ₁₀₄ , TR ₂₀₁ ~TR ₂₀₅ , TR ₄₀₁ ~TR ₄₀₃ , FET ₁₀₁ D ₂₀₁ , D ₂₀₂ , D ₄₀₁ ~D ₄₀₆ , D ₅₀₁ ~D ₅₀₃ TR ₁₀₃ , C ₁₂₇ , L ₁₀₄ TR ₂₀₁ , D ₂₀₃ , D ₂₀₄ , C ₂₀₈ , C ₂₃₀ , C ₂₃₁ Use measuring instruments for proper adjustment. TC ₁₀₁ ~TC ₁₀₄ , L ₁₀₁ , L ₁₀₂ , L ₁₀₃ , L ₁₀₅ L ₁₀₄ , T ₂₀₁ ~T ₂₀₅ T ₄₀₁ ~T ₄₀₃ for FM stereo
Distortion	A. Defective—overall section	See "Distortion—overall program sources".
	B. Defective FM or FM-MPX section <ol style="list-style-type: none"> 1. Divergence of voltage specified in "SCHEMATIC DIAGRAM" 2. Aging diode 3. Insufficient capacity of capacitor 	Measure voltage in FM or FM-MPX section and replace defective element. D ₂₀₁ , D ₂₀₂ , D ₄₀₁ ~D ₄₀₆ C ₂₀₅ , C ₂₀₉ , C ₂₁₂ , C ₂₁₄ , C ₄₀₁ , C ₄₀₃ , C ₄₀₈ , C ₄₁₁ , C ₄₁₂ , etc.

TROUBLESHOOTING CHART

FM OR FM-MPX RECEPTION (CONT'D)

SYMPTOM	PROBABLE CAUSE		CHECK POINT
Distortion (Cont'd)		<ol style="list-style-type: none"> 4. Divergence in adjustment of: <ol style="list-style-type: none"> a. Tracking b. I.F.T. c. MPX coil 5. Aging or weak transistor 	Use measuring instruments for proper adjustment. TC ₁₀₁ ~TC ₁₀₄ , L ₁₀₁ , L ₁₀₂ , L ₁₀₃ , L ₁₀₅ L ₁₀₅ , T ₂₀₁ ~T ₂₀₅ T ₄₀₁ ~T ₄₀₃ TR ₄₀₁ ~TR ₄₀₃
Hum	A. Defective—overall section		See "Hum—overall program sources".
	B. Defective FM or FM-MPX section	Insufficient capacity of capacitor	C ₀₀₉ , C ₀₁₀
	C. Defective power circuit	Aging or weak transistor	TR ₀₀₁
Noisy	A. Amplifier is not defective		See "General Section"
	B. Defective overall section		See "Noisy—overall program sources"
	C. Defective FM or FM-MPX section	<ol style="list-style-type: none"> 1. Divergence of voltage specified in "SCHEMATIC DIAGRAM" 2. Aging or weak transistor 3. Defective MPX coil 4. Resistor, rubbing or broken 5. Insufficient capacity of capacitor 6. Poor performance of FM AUTO (noisier in FM MONO) 7. Improper contact of rotary switch 8. Defective AGC circuit 	Measure voltage in FM or FM-MPX section and replace defective element. TR ₁₀₁ ~TR ₁₀₃ , TR ₂₀₁ ~TR ₂₀₅ , TR ₄₀₁ ~TR ₄₀₃ , FET ₁₀₁ T ₄₀₁ ~T ₄₀₃ R ₁₀₁ ~R ₁₁₄ , R ₂₀₁ ~R ₂₂₇ C ₁₀₁ ~C ₁₂₇ , C ₂₀₁ ~C ₂₂₂ , C ₄₀₁ , C ₄₀₃ , C ₄₁₁ TR ₅₀₁ ~TR ₅₀₄ , VR ₆₀₁ S _{1e} , S _{1f} , S _{1h} TR ₂₀₁ , D ₂₀₃ , D ₂₀₄ , C ₂₀₈ , C ₂₃₀ , C ₂₃₁
No MPX stereo sound (FM STEREO indicator lamp not lit)	A. Sub-carrier amplifying circuit defective	<ol style="list-style-type: none"> 1. Divergence of voltage specified in "SCHEMATIC DIAGRAM" 2. Aging or weak transistor 3. Aging or weak diode 4. Defective MPX coil 	Measure voltage in MPX indicator section and replace defective element. TR ₄₀₁ ~TR ₄₀₃ , TR ₅₀₁ ~TR ₅₀₅ D ₄₀₁ ~D ₄₀₆ , D ₅₀₁ ~D ₅₀₃ T ₄₀₁ ~T ₄₀₃ , T ₅₀₁
	B. Defective separation circuit	<ol style="list-style-type: none"> 1. Aging or weak transistor 2. Defective resistor 3. Insufficient capacity or short circuit of capacitor 	TR ₄₀₁ ~TR ₄₀₃ R ₄₀₆ ~R ₄₂₅ , R ₅₀₁ ~R ₅₁₁ C ₄₀₅ ~C ₄₂₀ , C ₅₀₁ ~C ₅₀₅
	C. Defective indicator circuit	<ol style="list-style-type: none"> 1. Divergence in adjustment of variable resistor 2. Divergence in adjustment of: a. MPX circuit 	VR ₅₀₁ , VR ₅₀₂ , VR ₆₀₁ Use measuring instruments for proper adjustment.

SYMPTOM	PROBABLE CAUSE		CHECK POINT
No MPX stereo sound (Cont'd)		b. Indicator circuit c. Pilot lamp out	T ₄₀₁ ~T ₄₀₃ , T ₅₀₁ PL ₅₀₁
Poor separation	Defective MPX section	1. Same as above. 2. Divergence of properties of circuit element (MPX coil and diode) due to temperature change	Same as above. Readjust VR ₆₀₁ . Taking account of the temperature change, Sansui has adjusted the circuit elements for the optimum conditions.
FM STEREO indicator lights on and off repeatedly, even though a station is not received.	A. Amplifier is O.K.		See "General Section"
	B. Defective stereo indicator circuit	1. Aging or weak transistor in indicator circuit 2. Divergence in adjustment of input and wrong action preventing circuit	TR ₅₀₃ ~TR ₅₀₅ VR ₅₀₁ , VR ₅₀₂
Tuning meter does not work normally.	A. Defective FM tuner		Same as above.
	B. Defective tuning indicator circuit		TR ₂₀₆ , D ₂₀₆ ~D ₂₀₉ , T ₂₀₅ , VR ₂₀₂ , R ₂₃₀ , R ₂₄₅ , R ₂₄₆ , C ₂₂₃ , C ₂₂₄ , C ₂₂₅
	C. Bad contact of SELECTOR switch		S ₁₁
MUTING switch does not work.	A. Defective MUTING circuit		TR ₂₀₆ ~TR ₂₀₈ , D ₂₀₆ , D ₂₀₇ , VR ₂₀₁ , C ₂₂₃ , C ₂₂₅ , C ₂₃₃ , R ₂₄₁ , R ₂₄₃
	B. Defective MUTING switch		S ₅

AM RECEPTION

SYMPTOM	PROBABLE CAUSE		CHECK POINT
No sound	A. Defective overall section		See "No sound—overall program sources".
	B. Defective AM section	1. Divergence of voltage specified in "SCHEMATIC DIAGRAM" 2. Aging or defective transistor 3. Aging or defective I.F.T. 4. Defective detector diode. 5. Aging or defective capacitor 6. Defective resistor	Measure voltage in AM section and replace defective element. TR ₃₀₁ ~TR ₃₀₅ T ₃₀₁ ~T ₃₀₅ D ₃₀₁ , D ₃₀₂ C ₃₀₁ , C ₃₁₀ , C ₃₁₂ , C ₃₁₄ , C ₃₁₈ , C ₃₁₉ , C ₃₂₃ etc. R ₃₀₁ , R ₃₀₃ , R ₃₀₅ , R ₃₀₆ , R ₃₀₉ , R ₃₁₀ , R ₃₁₅ , R ₃₁₆ , R ₃₁₉
Weak sound	A. Weak station signal		See "General Section"

TROUBLESHOOTING CHART

AM RECEPTION (CONT'D)

SYMPTOM	PROBABLE CAUSE	CHECK POINT	
Weak sound (Cont'd)	B. Defective overall section	<p>1. Divergence of voltage specified in "SCHEMATIC DIAGRAM"</p> <p>2. Voltage drop in local oscillator</p> <p>3. Detector diode, aging or weak</p> <p>4. Q or coil too low</p> <p>5. Insufficient capacity of capacitor</p> <p>6. Defective resistor</p> <p>7. Divergence in adjustment of:</p> <p>a. Tracking.</p> <p>b. I.F.T.</p>	<p>Measure voltage in AM section and replace defective element.</p> <p>TR₃₀₂, C₃₀₇, C₃₂₄, T₃₀₂</p> <p>D₃₀₂</p> <p>T₃₀₁~T₃₀₅</p> <p>C₃₀₁, C₃₀₂, C₃₀₈, C₃₁₀, C₃₁₂, C₃₁₃, C₃₂₄</p> <p>R₃₀₄, R₃₀₇, R₃₁₂, R₃₁₄, R₃₂₀, etc.</p> <p>For optimum adjustment, measuring instruments are often needed.</p> <p>TC₃₀₁~TC₃₀₃, L₃₀₁, T₃₀₁, T₃₀₂</p> <p>T₃₀₃~T₃₀₅</p>
	A. Defective overall section		See "Distortion—overall program sources"
Distortion	B. Defective AM section	<p>1. Divergence of voltage specified in "SCHEMATIC DIAGRAM"</p> <p>2. Detector diode, aging or weak</p> <p>3. Insufficient capacity of capacitor</p> <p>4. Divergence in adjustment</p> <p>5. Defective resistor</p> <p>6. Excessive antenna input</p>	<p>Measure voltage in AM section and replace defective element.</p> <p>D₃₀₂</p> <p>C₃₀₃, C₃₀₉, C₃₁₄, C₃₁₈, C₃₁₉ etc.</p> <p>See "Weak sound"</p> <p>Check antenna switch.</p>
	A. Defective overall section		See "Hum—overall program sources".
Hum	B. Defective AM section	Insufficient capacity of capacitor.	C ₀₁₀ , C ₃₁₄ , C ₃₂₁
	A. Amplifier is not defective		See "General section"
Noisy	B. Defective overall section		See "Noisy—overall program sources".
	C. Defective AM section	<p>1. Aging or defective transistor</p> <p>2. Loose contact of rotary switch.</p> <p>3. Broken lead in antenna circuit or shorted V.C.</p> <p>4. Defective RF circuit</p>	<p>TR₃₀₁~TR₃₀₅</p> <p>S_{1e}, S_{1f}, S_{1h}</p> <p>L₃₀₁ or VC₃₀₁</p> <p>VC₃₀₂, T₃₀₁</p>
	A. Defective AM tuner		Check as described above.
Tuning meter does not work normally.	B. Defective tuning indicator circuit		C ₃₁₅ , D ₃₀₃
	C. Bad contact of SELECTOR switch		S _{1i}

WITH RECORD PLAYER (MAGNETIC) OR TAPE DECK

SYMPTOM	PROBABLE CAUSE	CHECK POINT										
No sound	A. Program source defective	Check and repair or replace.										
	B. Defective overall section	See "No sound—overall program sources".										
	C. Divergence of voltage <table border="1" style="width: 100%; border-collapse: collapse;"> <tr> <td style="width: 30%;"></td> <td>1. Divergence of voltage specified in "SCHEMATIC DIAGRAM"</td> <td rowspan="5">Measure voltage in head amplifier section and replace defective element. C₆₀₁, C₆₀₆, C₆₀₇, C₆₁₁, C₆₁₆, C₆₁₇ R₆₀₁, R₆₁₂, R₆₁₈~R₆₂₉ S_{1a}, S_{1b}, S_{1c}, S_{1d}</td> </tr> <tr> <td></td> <td>2. Defective capacitor</td> </tr> <tr> <td></td> <td>3. Defective resistor</td> </tr> <tr> <td></td> <td>4. Loose contact of rotary switch</td> </tr> <tr> <td></td> <td>5. Loose contact of input terminal or pin jack</td> </tr> </table>		1. Divergence of voltage specified in "SCHEMATIC DIAGRAM"	Measure voltage in head amplifier section and replace defective element. C ₆₀₁ , C ₆₀₆ , C ₆₀₇ , C ₆₁₁ , C ₆₁₆ , C ₆₁₇ R ₆₀₁ , R ₆₁₂ , R ₆₁₈ ~R ₆₂₉ S _{1a} , S _{1b} , S _{1c} , S _{1d}		2. Defective capacitor		3. Defective resistor		4. Loose contact of rotary switch		5. Loose contact of input terminal or pin jack
	1. Divergence of voltage specified in "SCHEMATIC DIAGRAM"	Measure voltage in head amplifier section and replace defective element. C ₆₀₁ , C ₆₀₆ , C ₆₀₇ , C ₆₁₁ , C ₆₁₆ , C ₆₁₇ R ₆₀₁ , R ₆₁₂ , R ₆₁₈ ~R ₆₂₉ S _{1a} , S _{1b} , S _{1c} , S _{1d}										
	2. Defective capacitor											
	3. Defective resistor											
	4. Loose contact of rotary switch											
	5. Loose contact of input terminal or pin jack											
Weak sound	A. Program source defective	Check and repair or replace.										
	B. Defective overall section	See "Weak sound—overall program sources".										
	C. Defective head amplifier <table border="1" style="width: 100%; border-collapse: collapse;"> <tr> <td style="width: 30%;"></td> <td>1. Divergence of voltage specified in "SCHEMATIC DIAGRAM"</td> <td rowspan="5">Measure voltage in head amplifier section and replace defective element. C₆₀₁~C₆₀₇, C₆₁₁~C₆₁₇ S_{1a}, S_{1b}, S_{1c}, S_{1d}</td> </tr> <tr> <td></td> <td>2. Insufficient capacity of capacitor</td> </tr> <tr> <td></td> <td>3. Loose contact of rotary switch</td> </tr> <tr> <td></td> <td>4. Loose contact of input terminal or pin jack</td> </tr> <tr> <td></td> <td>5. Defective resistor</td> </tr> </table>		1. Divergence of voltage specified in "SCHEMATIC DIAGRAM"	Measure voltage in head amplifier section and replace defective element. C ₆₀₁ ~C ₆₀₇ , C ₆₁₁ ~C ₆₁₇ S _{1a} , S _{1b} , S _{1c} , S _{1d}		2. Insufficient capacity of capacitor		3. Loose contact of rotary switch		4. Loose contact of input terminal or pin jack		5. Defective resistor
	1. Divergence of voltage specified in "SCHEMATIC DIAGRAM"	Measure voltage in head amplifier section and replace defective element. C ₆₀₁ ~C ₆₀₇ , C ₆₁₁ ~C ₆₁₇ S _{1a} , S _{1b} , S _{1c} , S _{1d}										
	2. Insufficient capacity of capacitor											
	3. Loose contact of rotary switch											
	4. Loose contact of input terminal or pin jack											
	5. Defective resistor											
Distortion	A. Program source defective	Check and repair or replace.										
	B. Defective overall section	See "Distortion—overall program sources".										
	C. Defective head amplifier <table border="1" style="width: 100%; border-collapse: collapse;"> <tr> <td style="width: 30%;"></td> <td>1. Divergence of voltage specified in "SCHEMATIC DIAGRAM"</td> <td rowspan="4">Measure voltage in head amplifier section and replace defective element. C₆₀₁~C₆₀₇, C₆₁₁~C₆₁₇ R₆₀₁~R₆₁₇, R₆₁₈~R₆₃₄ TR₆₀₁~TR₆₀₄</td> </tr> <tr> <td></td> <td>2. Capacitor shorted or blown</td> </tr> <tr> <td></td> <td>3. Defective resistor</td> </tr> <tr> <td></td> <td>4. Weak transistor</td> </tr> </table>		1. Divergence of voltage specified in "SCHEMATIC DIAGRAM"	Measure voltage in head amplifier section and replace defective element. C ₆₀₁ ~C ₆₀₇ , C ₆₁₁ ~C ₆₁₇ R ₆₀₁ ~R ₆₁₇ , R ₆₁₈ ~R ₆₃₄ TR ₆₀₁ ~TR ₆₀₄		2. Capacitor shorted or blown		3. Defective resistor		4. Weak transistor		
	1. Divergence of voltage specified in "SCHEMATIC DIAGRAM"	Measure voltage in head amplifier section and replace defective element. C ₆₀₁ ~C ₆₀₇ , C ₆₁₁ ~C ₆₁₇ R ₆₀₁ ~R ₆₁₇ , R ₆₁₈ ~R ₆₃₄ TR ₆₀₁ ~TR ₆₀₄										
	2. Capacitor shorted or blown											
	3. Defective resistor											
	4. Weak transistor											
Hum	A. Program source defective	Check and repair or replace.										
	B. Amplifier is not defective	Improper connections	See "General Section"									
	C. Defective overall section		See "Hum—overall program sources".									
	D. Defective head amplifier	Insufficient capacity of capacitor	C ₀₀₇									
Noisy	A. Program source defective	Check and repair or replace.										

TROUBLESHOOTING CHART

WITH RECORD PLAYER OR TAPE DECK (CONT'D)

SYMPTOM	PROBABLE CAUSE	CHECK POINT
Noisy (Cont'd)	B. Amplifier is not defective	See "General Section"
	C. Defective overall section	See "Noisy—overall program sources"
	D. Defective head amplifier	<ol style="list-style-type: none"> 1. Fixed resistor defective 2. Defective capacitor 3. Weak transistor

OTHER PROGRAM SOURCES

SYMPTOM	PROBABLE CAUSE	CHECK POINT
Record player with crystal cartridge does not operate properly.	<ol style="list-style-type: none"> 1. Program source defective 2. Improper or incorrect connections 3. Defective overall section 	Check and repair or replace. See "General Section". See "Overall Program Sources"
Sound input from additional tuner or other components is not reproduced properly.	<ol style="list-style-type: none"> 1. Program source defective 2. Improper or incorrect connections 3. Defective overall section 	Check and repair or replace. See "General Section". See "Overall Program Sources".
Pin-jack tape recorder does not operate properly.	<ol style="list-style-type: none"> 1. Program source defective 2. Improper or incorrect connections 3. Defective overall section 	Check and repair or replace. See "General Section". See "Overall Program Sources"
One-connection tape recorder (DIN standard) does not operate properly.	<ol style="list-style-type: none"> 1. Program source defective 2. Improper or incorrect connections 3. Defective overall section 4. Defective input circuit 	Check and repair or replace. See "General Section". See "Overall Program Sources". DIN jack $R_{639} \sim R_{641}$

RECORDING ON TAPE

SYMPTOM	PROBABLE CAUSE	CHECK POINT
Broadcast is not recorded well.	<ol style="list-style-type: none"> 1. Defective tape or tape recorder 2. Improper or incorrect connections 3. FM, FM-MPX or AM section defective 	Check and repair or replace. See "General Section". See "AM", "FM" or "FM-MPX Reception".
Record is not recorded Well.	<ol style="list-style-type: none"> 1. Defective tape or tape recorder 2. Improper or incorrect connections 3. Record or record player defective 4. Defective head amplifier 	Check and repair or replace. See "General Section". Check and repair or replace. See "Using with Record Player: Defective head amplifier"

ALIGNMENT POINTS AND PROCEDURES

TEST POINTS

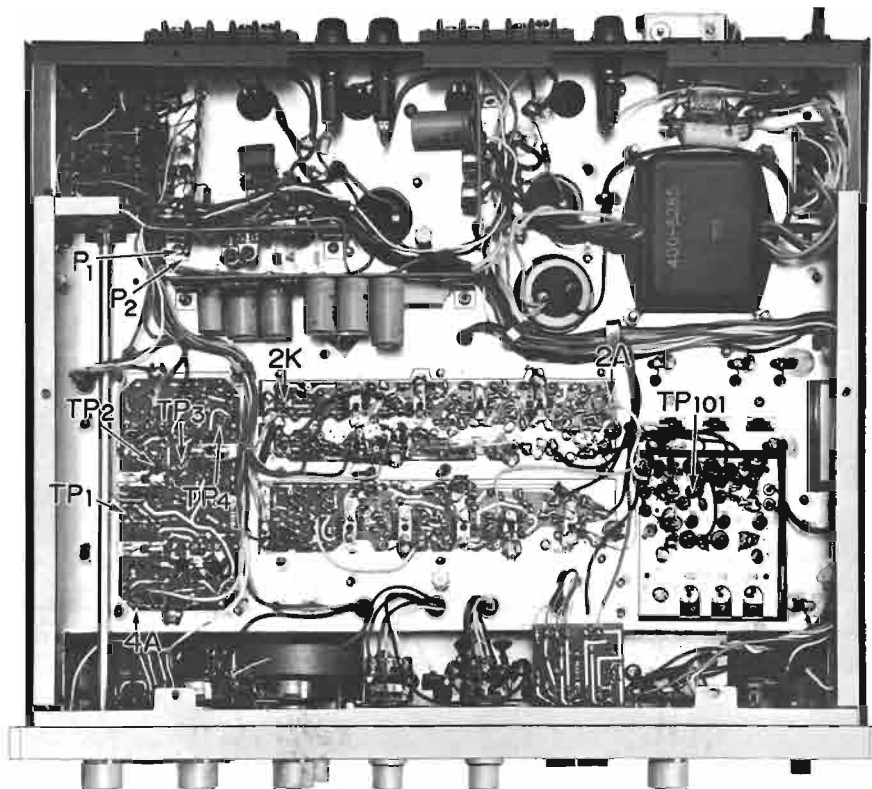
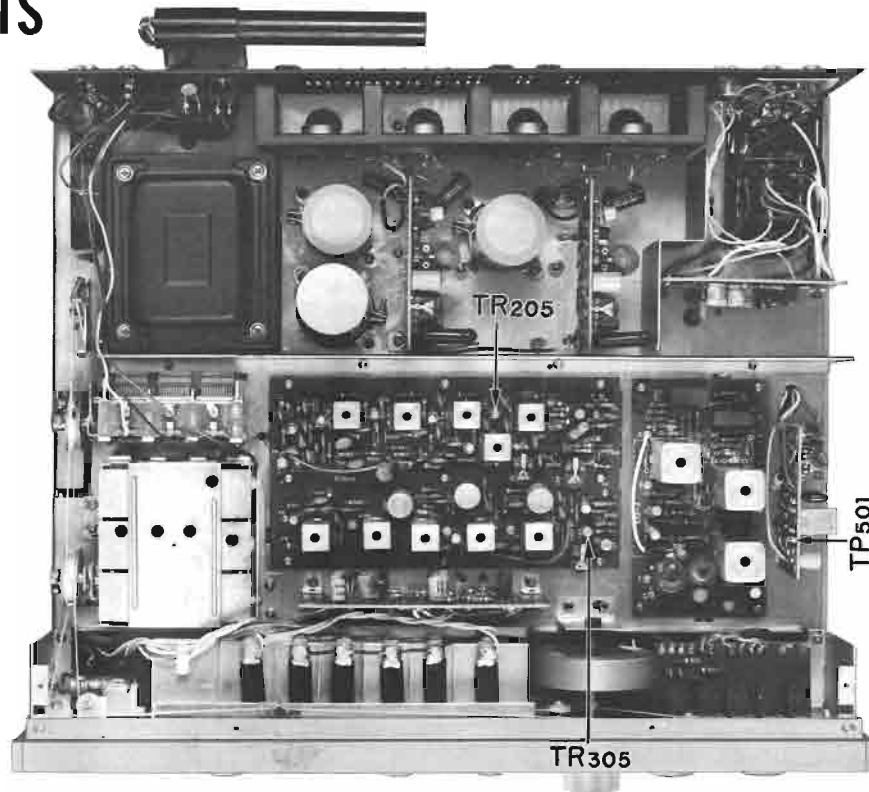

ALIGNMENT

FM ALIGNMENT PROCEDURE

NOTE: To align, set the FM signal generator level to minimum, turn tuning gang fully, center carrier wave, and set pointer to reference mark.

STEP	ALIGN	GENERATOR	FEED SIGNAL	OUTPUT INDICATOR	DIAL SETTING	ADJUST	ADJUST FOR
1.	IF Transformer	10.7 MHz ± 200 KHz	Sweep signal is sent to TP ₁₀₁ via the 0.02pF ceramic capacitor	Oscilloscope is connected to TR ₂₀₂ emitter, and then TR ₂₀₅ collector to ground via the 0.05μF ceramic capacitor		Primary and secondary sides of L ₁₀₄ T ₂₀₁ , T ₂₀₂ and T ₂₀₃	Best I.F.T. wave form
2.	Discriminator	10.7 MHz ± 200 KHz	Sweep signal is sent to 2A via the 0.05μF ceramic capacitor	Oscilloscope is connected to 2K via the 0.05μF capacitor		FM Discriminator transformer T ₂₀₄ primary and secondary	S curve
3.	O.S.C.	88 MHz 400 Hz 100% Modulation	To antenna terminals	Oscilloscope and V.T.V.M. at output load	88 MHz	O.S.C. coil L ₁₀₅	Maximum
4.	O.S.C.	108 MHz 400 Hz 100% Modulation	To antenna terminals	Oscilloscope and V.T.V.M. at output load	108 MHz	O.S.C. trimmer TC ₁₀₄	Maximum
5.	Repeat 3 & 4						
6.	RF Amp. Circuit	90 MHz 400 Hz 100% Modulation	To antenna terminals	Oscilloscope and V.T.V.M. at output load	90 MHz	Antenna coil L ₁₀₁ , L ₁₀₂ and L ₁₀₃	Maximum
7.	RF Amp. Circuit	106 MHz 400 Hz 100% Modulation	To antenna terminals	Oscilloscope and V.T.V.M. at output load	106 MHz	Trimmer TC ₁₀₁ , TC ₁₀₂ and TC ₁₀₃	Maximum
8.	Repeat 6 & 7						

FM IF CHARACTERISTIC

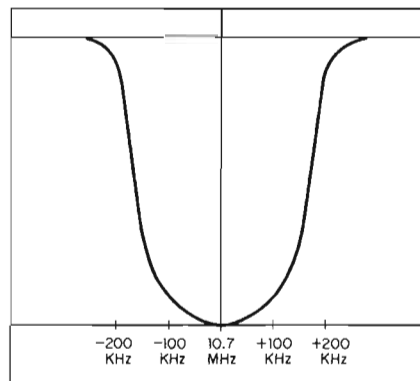

FM DISCRIMINATOR CHARACTERISTIC

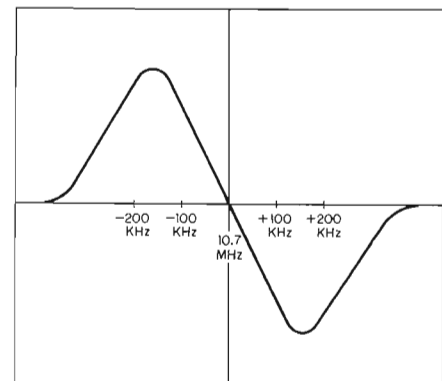

FM M.P.X. ALIGNMENT PROCEDURE

1. Do not attempt to align the Multiplex Circuit unless the following equipment is available:

a. Multiplex Stereo Generator b. Oscilloscope c. AC. V.T.V.M. d. Audio Oscillator e. FM Signal Generator

STEP	ALIGN	GENERATOR	FEED SIGNAL	OUTPUT INDICATOR	ADJUST	ADJUST FOR
1.	67 KHz Trap	67 KHz Audio Signal	Connect to TP _{4A}	V.T.V.M. at TP ₄	L ₄₀₁ (MFC-A)	Minimum
2.	71 KHz Trap	71 KHz Audio Signal	Connect to TP _{4A}	V.T.V.M. at TP ₄	L ₄₀₂ (MFC-B)	Minimum
3.	19 KHz Transformer	FM Signal Gen. Modulated 30% by STEREO Gen. sub-channel	Antenna terminals Tune to signal	V.T.V.M. and Oscilloscope at TP ₁	T ₄₀₁ (MPT-20A)	Minimum
4.	19 KHz Transformer	FM Signal Gen. Modulated 30% by STEREO Gen. sub-channel	Antenna terminals Tune to signal	V.T.V.M. and Oscilloscope at TP ₃	T ₄₀₂ (MPT-20B)	Smaller peak value of two peak values
5.	38 KHz Transformer	FM Signal Gen. Modulated 30% by STEREO Gen. sub-channel	Antenna terminals Tune to signal	V.T.V.M. and Oscilloscope at TP ₃	T ₄₀₃ (MPT-20B)	Smaller peak value of two peak values
6.	38 KHz Transformer and Separation VR	FM Signal Gen. Modulated 30% by STEREO Signal Gen. channel-L	Antenna terminals Tune to signal	V.T.V.M. and Oscilloscope at output load channel-R	T ₄₀₃ (MPT-20B) within ¼ turn and Separation VR(VR ₆₀₁)	Channel-R Minimum

ALIGNMENT

AM ALIGNMENT PROCEDURE

NOTE: To align, set the AM Signal Generator level to minimum.

STEP	ALIGN	GENERATOR	FEED SIGNAL	OUTPUT INDICATOR	DIAL SETTING	ADJUST	ADJUST FOR
1.	I.F. Transformer	455 KHz ±30 KHz Sweep-generator	Antenna terminals	Oscilloscope and V.T.V.M. is connected to TR ₃₀₅ emitter		Primary and secondary sides from the 1st I.F.T. (T ₃₀₃) to the 3rd I.F.T. (T ₃₀₅)	Best I.F.T. wave form
2.	O.S.C.	AM-generator 600 KHz 400 Hz 30% Modulation	Antenna terminals	Oscilloscope and V.T.V.M. at output load	600 KHz	O.S.C. Coil T ₃₀₂	Maximum
3.	O.S.C.	AM-generator 1400 KHz 400 Hz 30% Modulation	Antenna terminals	Oscilloscope and V.T.V.M. at output load	1400 KHz	O.S.C. Trimmer cap. TC ₃₀₃	Maximum
4.	Repeat 2 and 3						
5.	RF amp.	AM-generator 600 KHz 400 Hz 30% Modulation	Antenna terminals	Oscilloscope and V.T.V.M. at output load	600 KHz	RF transformer T ₃₀₁	Maximum
6.	Antenna circuit	AM-generator 600 KHz 400 Hz 30% Modulation	Antenna terminals	Oscilloscope and V.T.V.M. at output load	600 KHz	Ferrite bar Antenna coil L ₃₀₁	Maximum
7.	RF amp.	AM-generator 1400 KHz 400 Hz 30% Modulation	Antenna terminals	Oscilloscope and V.T.V.M. at output load	1400 KHz	RF Trimmer TC ₃₀₂	Maximum
8.	Antenna circuit	AM-generator 1400 KHz 400 Hz 30% Modulation	Antenna terminals	Oscilloscope and V.T.V.M. at output load	1400 KHz	Antenna circuit Trimmer TC ₃₀₁	Maximum
9.	Repeat 5, 6, 7, 8						

AM IF CHARACTERISTIC

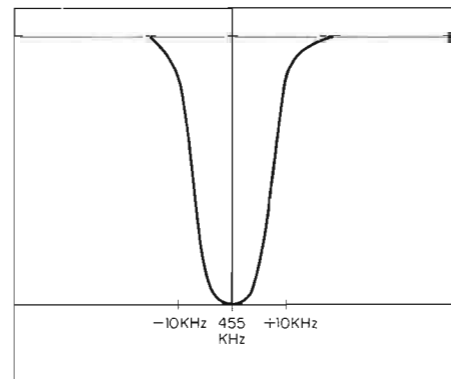

TO ADJUST THE PROTECTOR CIRCUIT (F-1015)

1. Remove wiring from P_1 and P_2 .
2. Send a 5-volt RMS signal (1 kHz) to P_1 and adjust VR_{901} to make the protector lamp glow.
3. Send a 5-volt RMS signal (1 kHz) to P_2 and adjust VR_{902} to make the protector lamp glow.
4. Attach wiring to P_1 and P_2 in its original place.

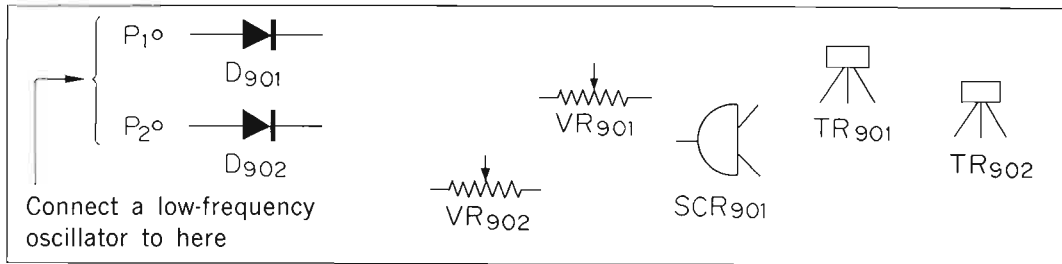

TO ADJUST THE BIAS CURRENT IN THE OUTPUT STAGE

1. Set the MAIN VOL. control to the MINIMUM position.
2. Connect a resistor (approx. 10 ohms and 1 watt) to each of the SPEAKER output terminals.
3. Remove quick-acting fuse from its holder.
4. Connect an ammeter (about 100 milliamperes) to CHANNEL R as illustrated.
5. Adjust the VR_{804} on F-1001C sheet so that the ammeter indicates 25 milliamperes.
6. Remove the ammeter and secure the fuse in place.
7. Adjust CHANNEL L as above.

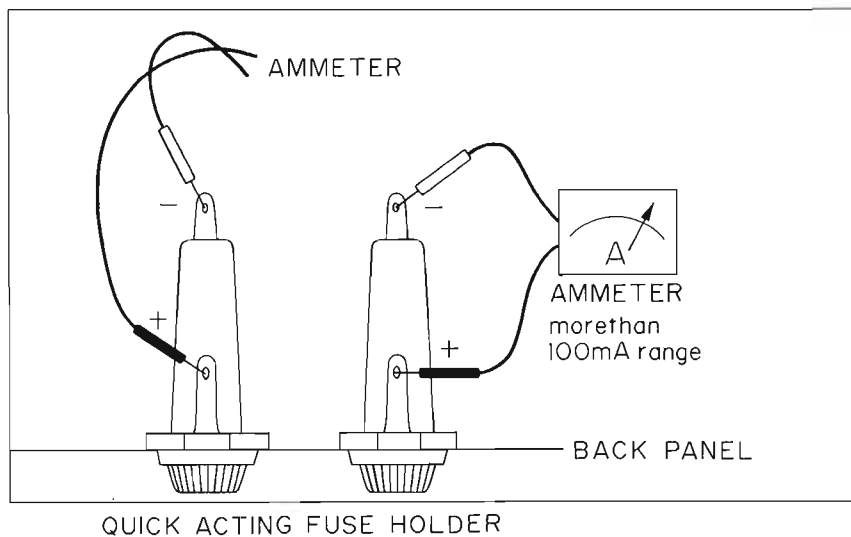

SCHEMATIC DIAGRAM OF CIRCUITS

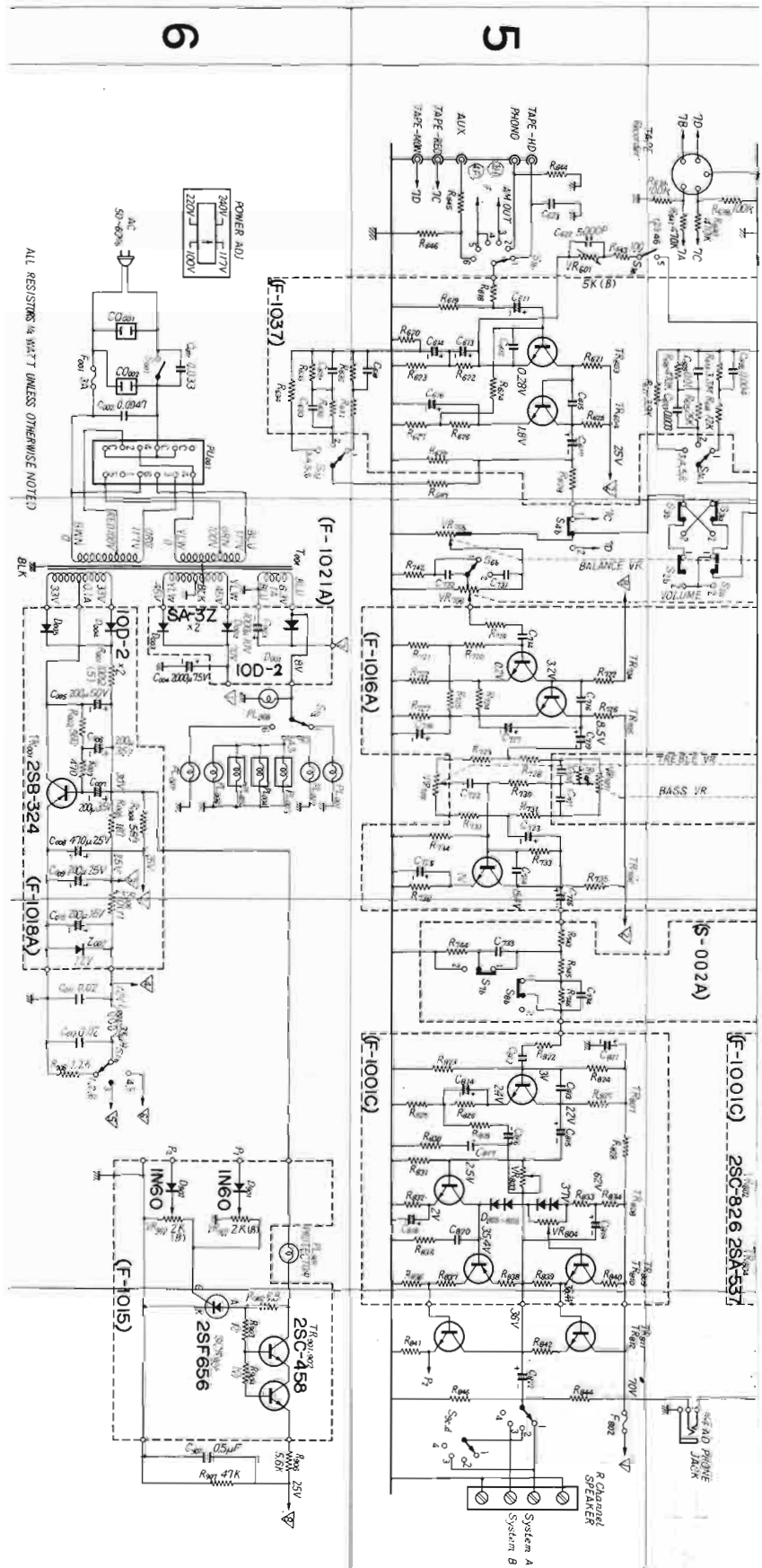

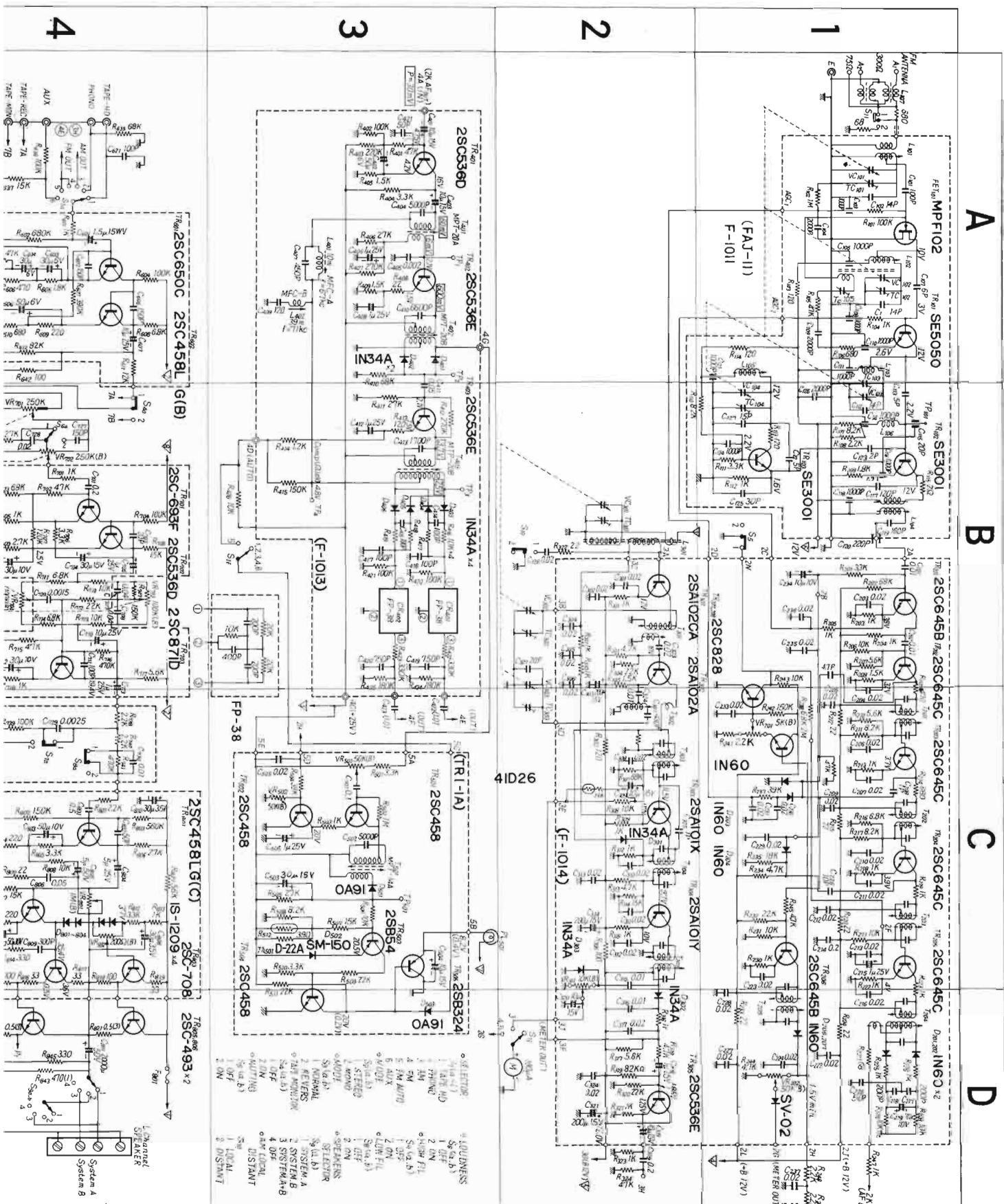

A **B** **C** **D**

DISASSEMBLY PROCEDURE

REMOVING THE FRONT PANEL, BONNET AND BOTTOM PLATE

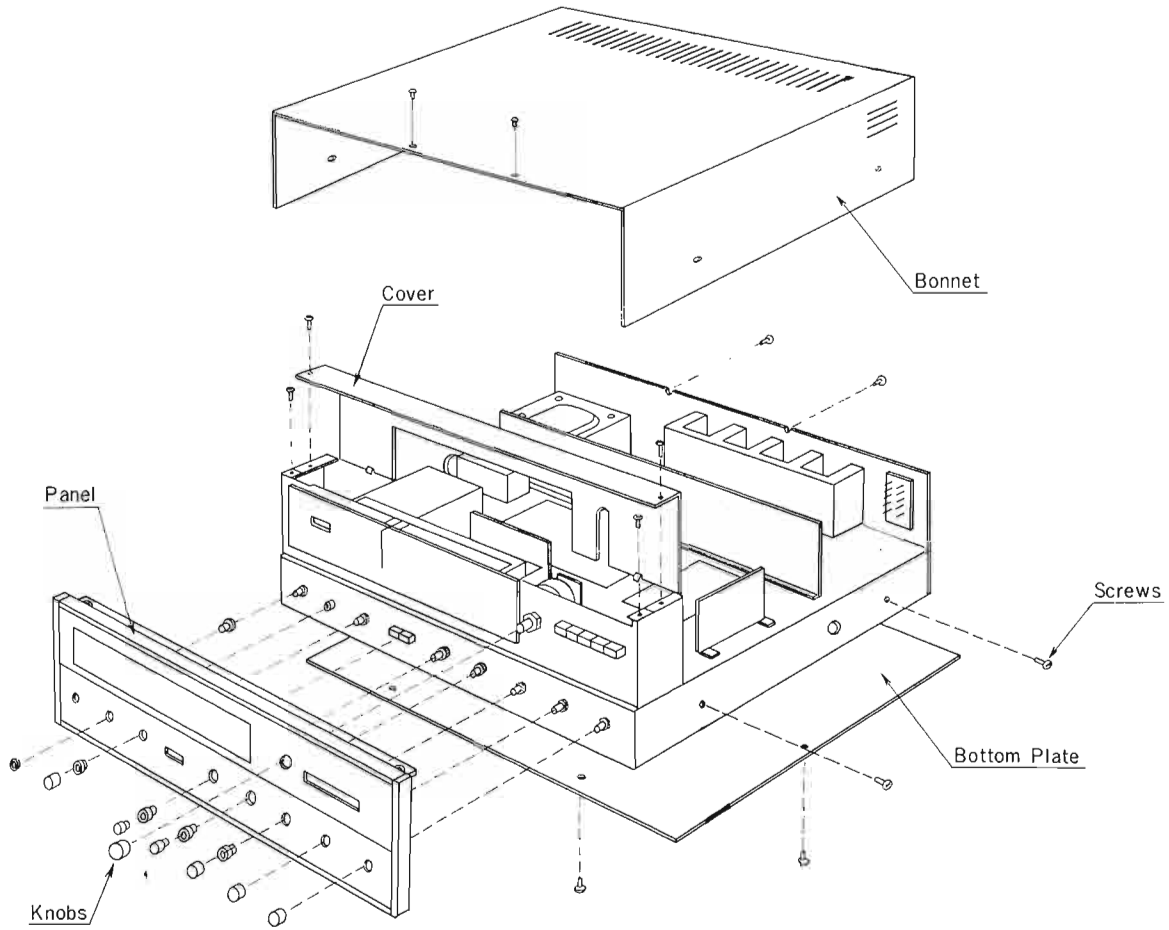

DIAL MECHANISM

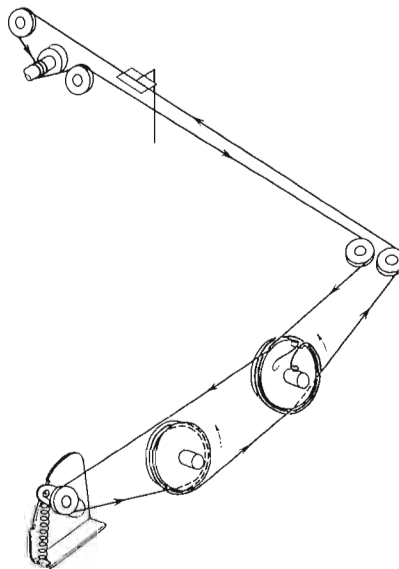

BLOCK DIAGRAM OF PRINTED CIRCUITS

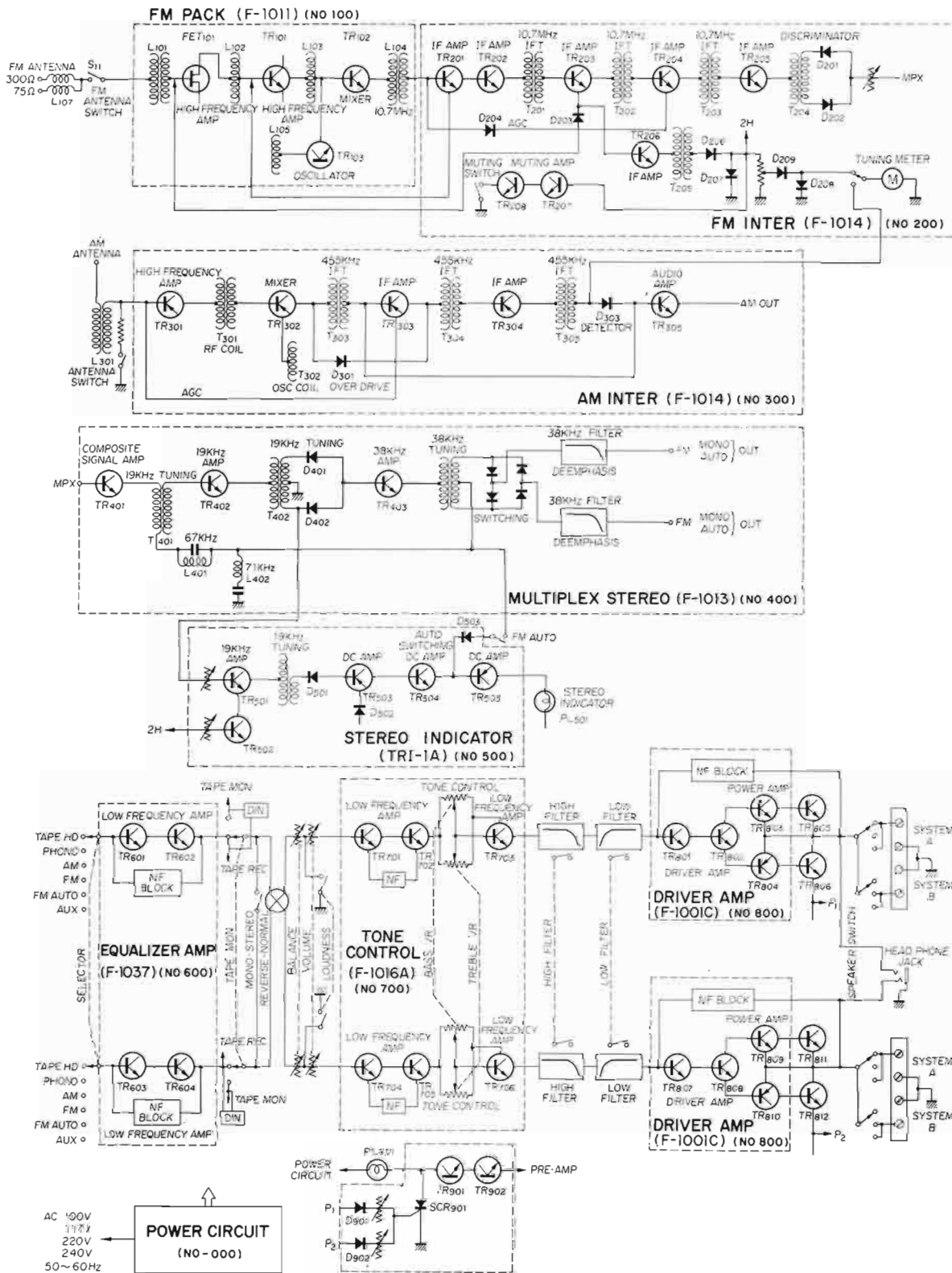

PARTS LAYOUT

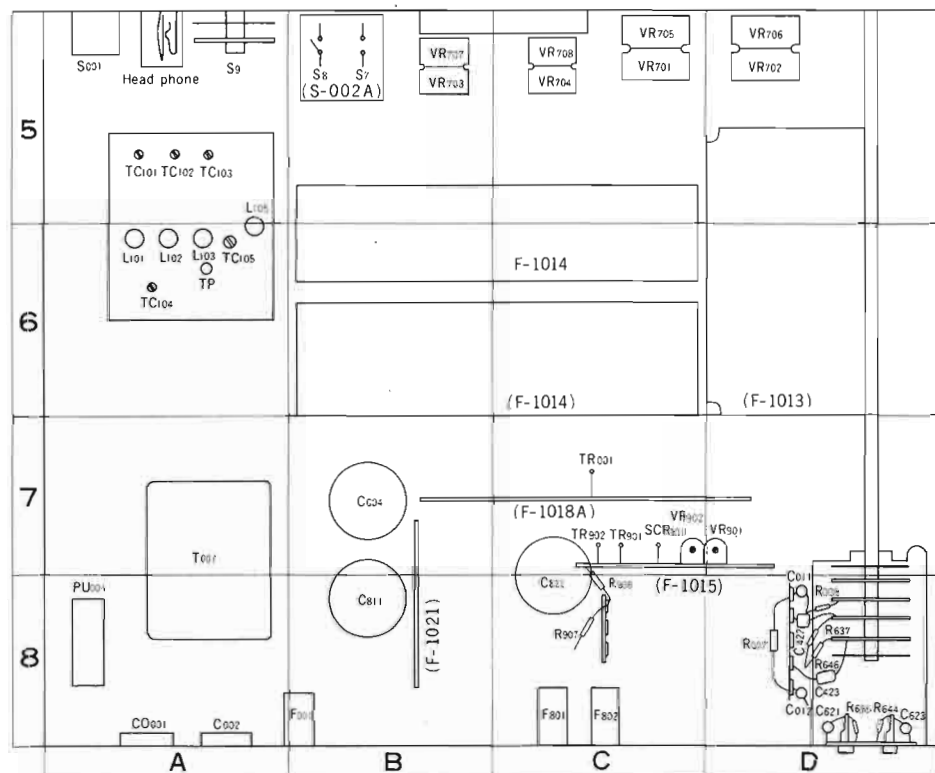
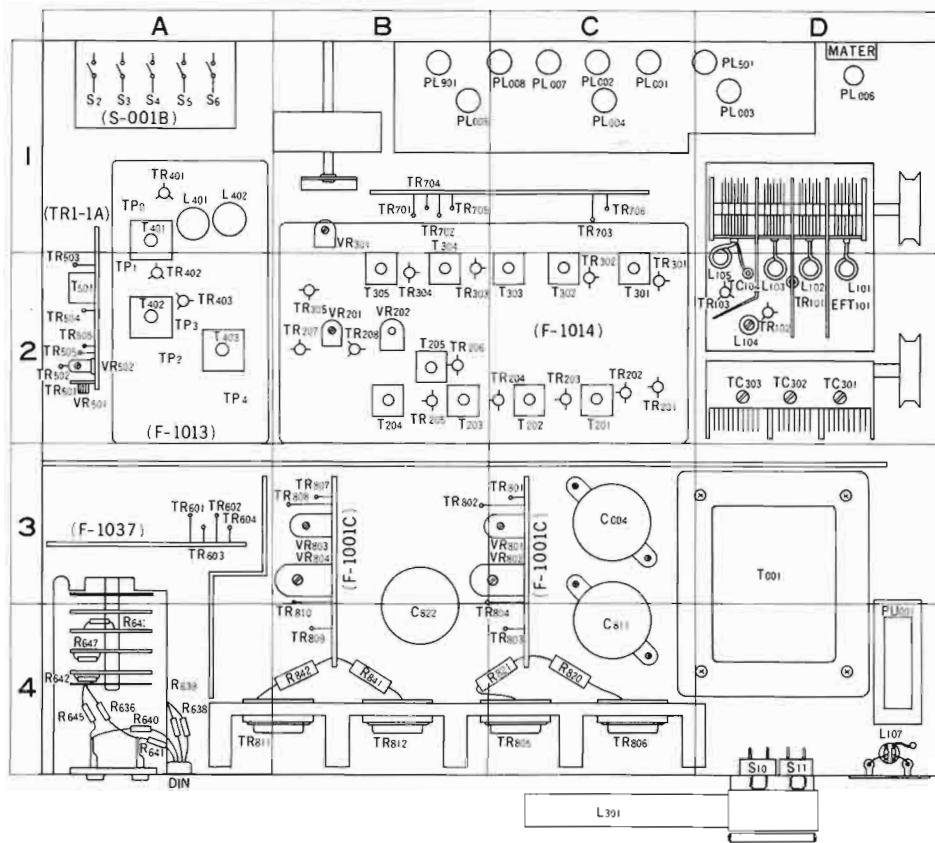

PRINTED-CIRCUIT SHEETS

EQUALIZER AMP F-1037

CO-ORDINATES OF PARTS USED

R601...1 A	R616...1 B	R631...2 C	C611...2 A
R602...1 A	R617...1 B, C	R632...2 C	C612...2 A
R603...1 B	R618...2 A	R633...2 B	C613...2 A
R604...1 A	R619...2 A	R634...2 B, C	C614...2 A
R605...1 A	R620...2 B		C615...2 B
R606...1 B	R621...2 A	C601...1 A	C616...2 B
R607...1 A, B	R622...2 A	C602...1 A	C617...2 B
R608...1 B	R623...2 B	C603...1 A	C618...2 B
R609...1 B	R624...2 A, B	C604...1 A	C619...2 B
R610...1 B	R625...2 B	C605...1 B	C620...2 C
R611...1 C	R626...2 B	C606...1 B	
R612...1 C	R627...2 B	C607...1 B	TR601...1 A
R613...1 B, C	R628...2 C	C608...1 B	TR602...1 B
R614...1 C	R629...2 C	C609...1 B	TR603...1 A
R615...1 C	R630...2 B	C610...1 C	TR604...2 B

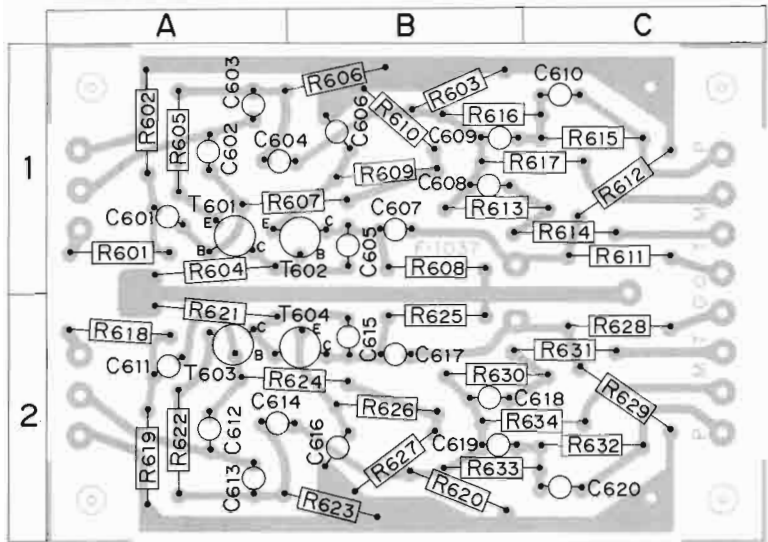

CONTROL AMP F-1016A

CO-ORDINATES OF PARTS USED

R701...1 D	R710...1 B, C	R719...2 D	R727...2 C	R735...2 B	C706...1 C	C716...2 C	C726...2 A
R703...1 C, D	R711...1 B	R720...2 D	R728...2 B, C	R736...2 A	C709...1 B	C717...2 C	
R704...1 C, D	R712...1 B	R721...2 C, D	R729...2 B		C710...1 B	C718...2 C	TR701...1 C
R705...1 C	R713...1 B	R722...2 C, D	R730...2 B	C701...1 D	C711...1 A	C719...2 C	TR702...1 C
R706...1 C	R714...1 B	R723...2 C	R731...2 B	C702...1 D	C712...1 A	C722...2 B	TR703...1 A
R707...1 C	R716...1 A	R724...2 C	R732...2 B	C703...1 C	C713...1 A	C723...2 B	TR704...2 C
R708...1 C	R717...1 B	R725...2 C	R733...2 A	C704...1 C	C714...2 D	C724...2 A	TR705...2 C
R709...1 C	R718...1 A	R726...2 C	R734...2 A	C705...1 C	C715...2 D	C725...2 A	TR706...2 A

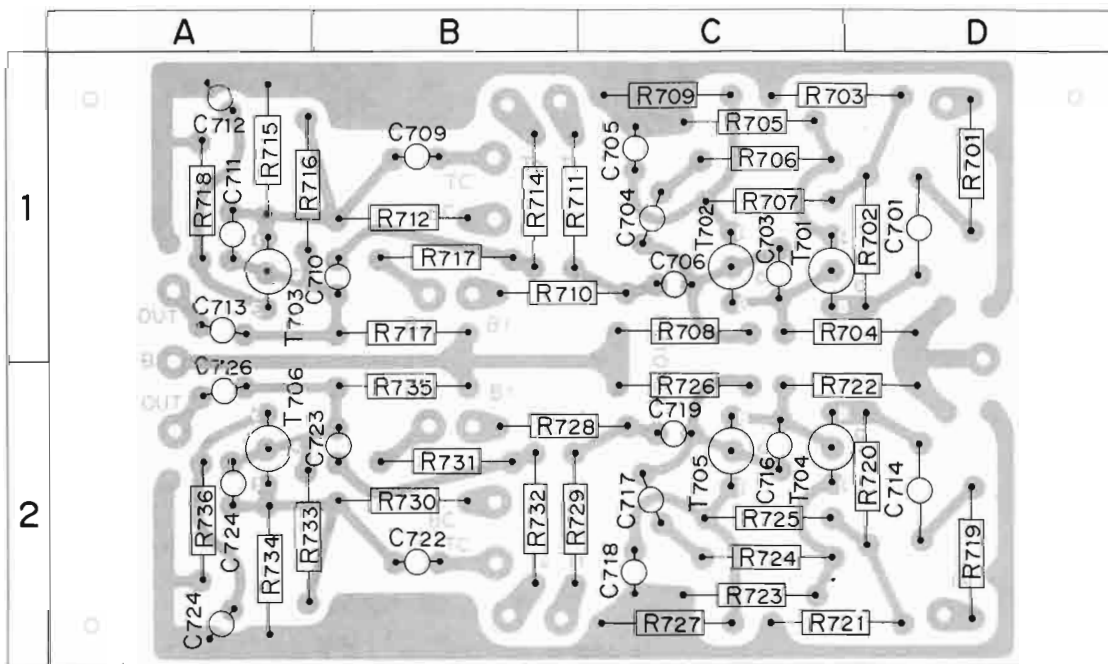

DRIVER AMP. F-1001C

CO-ORDINATES OF PARTS USED

R801...1, 2 A	R815...2 B	C809...2 A, B
R802...2 A	R816...2 B	C810...2 A
R803...1 A	R817...2 B	
R804...2 A	R818...1, 2 B	TR801...1 A
R805...2 A	R819...1 B	TR802...1 A
R806...1 A		TR803...1 B
R807...1 B	C801...1 A	TR804...2 B
R808...2 A	C802...1 A	
R809...2 B	C803...2 A	D801...1 B
R810...2 A	C804...1 A	D802...1 B
R811...2 A	C805...2 B	D803...1 B
R812...1 B	C806...2 B	D804...1 A, B
R813...1 B	C807...2 A	
R814...2 B	C808...1 A	

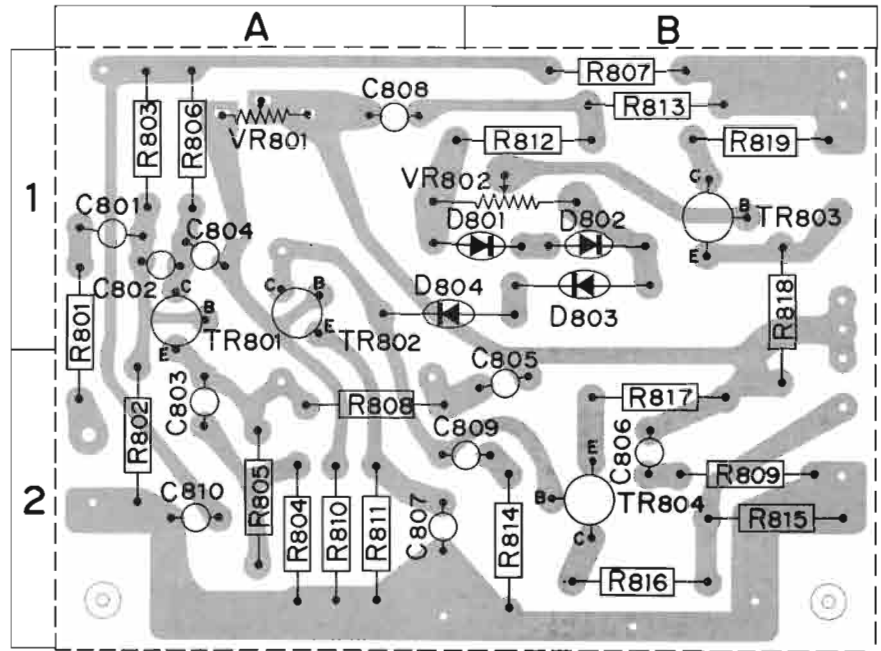

FM TUNER F-1011

PARTS NAME

① C101	C110	④ C104	⑨ C119	⑬ R102	⑳ R106	⑳ FET101	⑳ L105	TC104
② C102	C111	⑤ C109	⑩ C120	⑭ R103	㉑ R107	㉑ TR101	㉑ L104	㉑ TC105
C106	C114	⑥ C126	⑪ C122	⑮ R113	㉒ R108	㉒ TR102	㉒ L106	
C112	C116	⑦ C107	⑫ C123	⑯ R114	㉓ R109	㉓ TR103	㉓ T101	
③ C103	C118	⑧ C113	⑬ C125	⑰ R104	㉔ R110	㉔ L101	㉔ TC101	
C105	C121	⑨ C115	⑭ C127	⑱ R112	㉕ R111	㉕ L102	㉕ TC102	
C108	C124	⑩ C117	⑮ R101	⑲ R105	㉖ R115	㉖ L103	㉖ TC103	

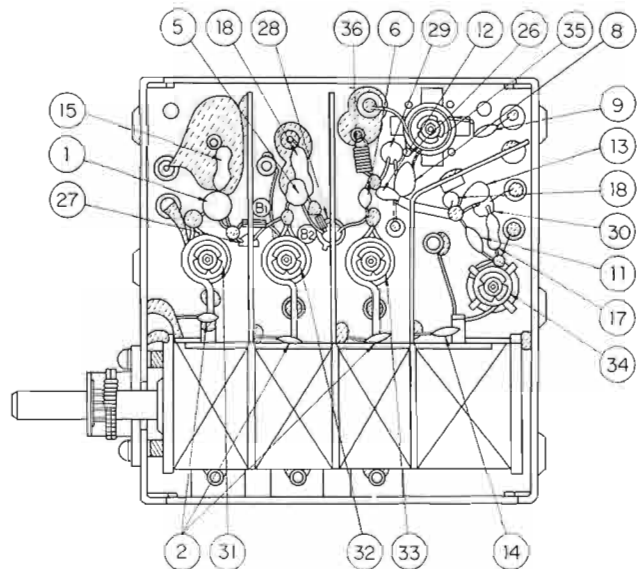
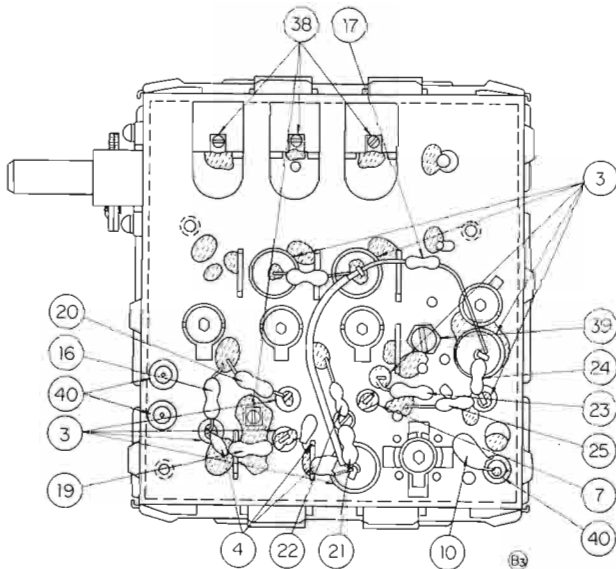

PRINTED-CIRCUIT SHEETS

FM, AM IFT F-1014

CO-ORDINATES OF PARTS USED

R201 ... 2 A	R313 ... 3, 4 D	C311 ... 4 D
R202 ... 1 A	R314 ... 4 E	C312 ... 3 E
R203 ... 2 A	R315 ... 3D, E	C313 ... 3 E
R204 ... 1 A	R316 ... 3 E	C314 ... 3 D
R205 ... 2 A	R317 ... 3 E	C315 ... 4 E
R206 ... 1 A	R318 ... 3 F	C316 ... 3 E
R207 ... 2 A	R319 ... 3 F	C317 ... 3 E
R208 ... 2 B	R320 ... 3 F	C318 ... 3 F
R209 ... 1 B	R321 ... 4 F	C319 ... 4 F
R210 ... 2 B		C320 ... 4 F
R211 ... 2 B	C201 ... 1 A	C321 ... 3 E
R212 ... 1 B	C202 ... 1, 2 A	C323 ... 3, 4 B
R213 ... 2 B	C203 ... 2 A	C324 ... 3 C
R214 ... 2 C	C204 ... 2 A	C325 ... 3, 4 D
R215 ... 1 C	C205 ... 1 A	C326 ... 3 E
R216 ... 2 C	C206 ... 2 B	C327 ... 4 C
R217 ... 1 C	C207 ... 2 B	
R218 ... 2 C	C208 ... 2 B	TR201 ... 1, 2A
R219 ... 1 D	C209 ... 1 B	TR202 ... 1, 2A
R220 ... 1 D	C210 ... 2 C	TR203 ... 1 B
R221 ... 1 D	C211 ... 2 C	TR204 ... 1 C
R222 ... 1 D	C212 ... 1 C	TR205 ... 1 D
R223 ... 1 E	C213 ... 1, 2 D	TR206 ... 2 D
R224 ... 1 E	C214 ... 1 D	TR207 ... 2 F
R225 ... 1 E	C215 ... 2E, F	TR208 ... 2 E
R226 ... 1 E	C216 ... 1, 2 D	TR301 ... 3 A
R227 ... 1 E	C217 ... 1 F	TR302 ... 3, 4B
R228 ... 2 E	C218 ... 1 F	TR303 ... 4C, D
R229 ... 1 F	C219 ... 1 F	TR304 ... 4D, E
R230 ... 2 D	C220 ... 1 F	TR305 ... 3 F
R231 ... 2 D	C222 ... 1 F	
R232 ... 2 D	C223 ... 2 F	D201 ... 2 E
R233 ... 2 D	C224 ... 2 E	D202 ... 1 E
R234 ... 2 C	C226 ... 2 C	D203 ... 2 B
R235 ... 2 C	C227 ... 2 E	D204 ... 2 C
R236 ... 2 C	C228 ... 2 C	D206 ... 2 E
R237 ... 2 B	C229 ... 2 B	D301 ... 3 C
R238 ... 1 F	C230 ... 2 B	D302 ... 3, 4 E
R241 ... 2 F	C231 ... 2 B	D303 ... 4 E
R242 ... 2 F	C233 ... 2 F	VR201 ... 2E, F
R243 ... 2 F	C234 ... 2 A	VR202 ... 2 E
R301 ... 3 A	C235 ... 2 A	VR203 ... 4 F
R302 ... 3 C	C236 ... 2 A	
R303 ... 3 B	C301 ... 3 A	T201 ... 1 B
R304 ... 4 B	C302 ... 3A, B	T202 ... 1 C
R305 ... 3 B	C303 ... 3 C	T203 ... 1 D
R306 ... 3 E	C304 ... 3 A	T204 ... 1 E
R307 ... 4 C	C305 ... 3 C	T205 ... 2 D
R308 ... 4 D	C306 ... 2 D	T301 ... 4 A
R309 ... 3 D	C307 ... 4 C	T302 ... 4 B
R310 ... 3 D	C308 ... 4 C	T303 ... 4 C
R311 ... 3 C	C309 ... 4 D	T304 ... 4 D
R312 ... 3 D	C310 ... 3 D	T305 ... 4 E

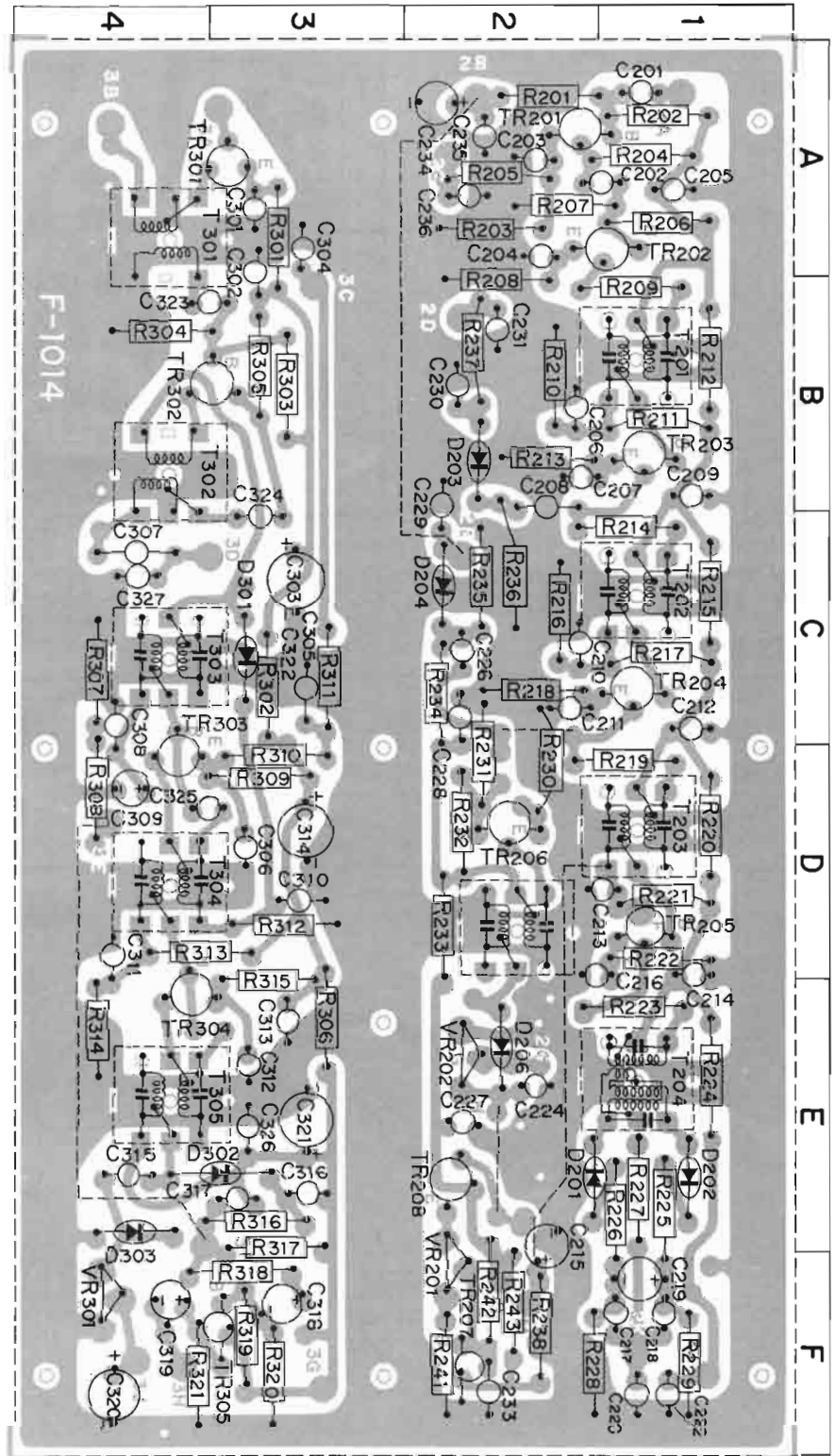

FM MULTIPLEX F-1013

CO-ORDINATES OF PARTS USED

R401 ... 1 C	R409 ... 2 B	R417 ... 2 A	R425 ... 1 A	C407 ... 1, 2 C	C415 ... 2 A	CR401 ... 1 A	D402 ... 1 B	T401 ... 1 C
R402 ... 2 C	R410 ... 1 A	R418 ... 2 A		C408 ... 2 B	C416 ... 1 A	CR402 ... 2 A	D403 ... 2 A, B	T402 ... 1 B
R403 ... 2 C	R411 ... 2 B	R419 ... 2 A	C401 ... 1 C	C409 ... 1 C	C417 ... 2 A		D404 ... 2 A	T403 ... 2 A, B
R404 ... 1, 2 C	R412 ... 2 B	R420 ... 1 A	C402 ... 1, 2 C	C410 ... 1 B	C418 ...	TR401 ... 1 C	D405 ... 1 A, B	
R405 ... 2 C	R413 ... 2 B	R421 ... 2 A	C403 ... 1 C	C411 ... 2 B	C419 ... 1 A	TR402 ... 2 B	D406 ... 2 A	
R406 ... 2 B	R414 ... 2 B	R422 ... 1 A	C404 ... 1 C	C412 ... 2 B	C420 ... 1 A	TR403 ... 2 B		
R407 ... 2 B	R415 ... 2 A, B	R423 ... 1 A	C405 ... 1 B	C413 ... 2 B	C421 ... 1 C		L401 ... 1, 2 C	
R408 ... 2 B	R416 ... 2 A	R424 ... 1 A	C406 ... 2 C	C414 ... 2 A		D401 ... 1 A	L402 ... 2 C	

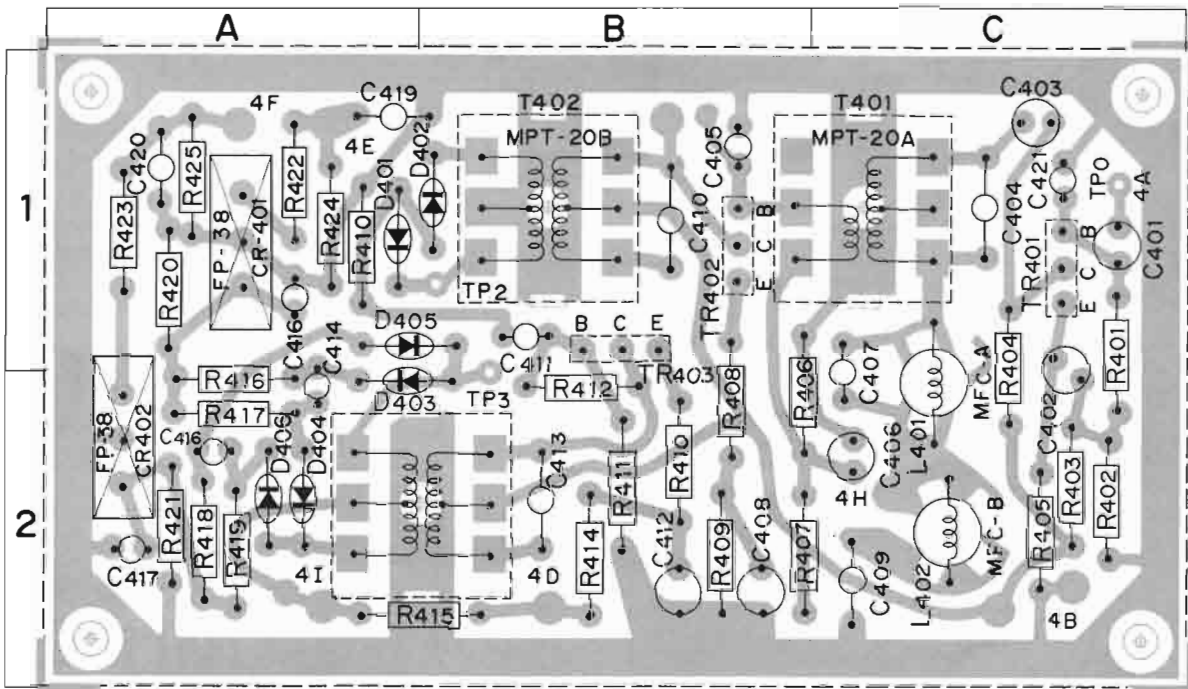

FM STEREO INDICATOR TRI-1A

CO-ORDINATES OF PARTS USED

R501 ... 2 A	R510 ... 2 C	T501 ... 1 B	TR503 ... 2 B
R502 ... 1 A	R511 ... 2 B		TR504 ... 2 B
R503 ... 1 A	R512 ... 2 C	VR501 ... 1 A	TR505 ... 2 A
R504 ... 1 A		VR502 ... 1 A	
R505 ... 1 C	C501 ... 1 A		D501 ... 1 C
R506 ... 1 C	C502 ... 1 B	TH501 ... 2 C	D502 ... 1 B
R507 ... 2 C	C503 ... 1 C		D503 ... 2 A
R508 ... 2 C	C504 ... 2 A	TR501 ... 1 A	
R509 ... 2 C	C505 ... 1 A	TR502 ... 1 A	

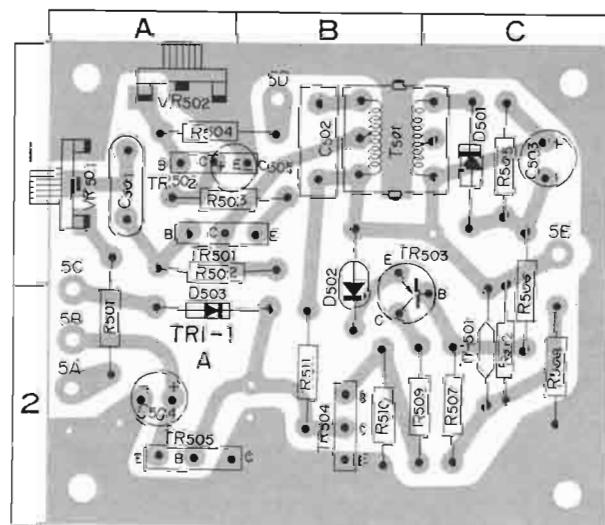

PRINTED-CIRCUIT SHEETS

HIGH-LOW FILTER S-002A

PARTS NAME

R738	R743	C729
R739	R744	C730
R740	R745	C733
R741	R746	C734

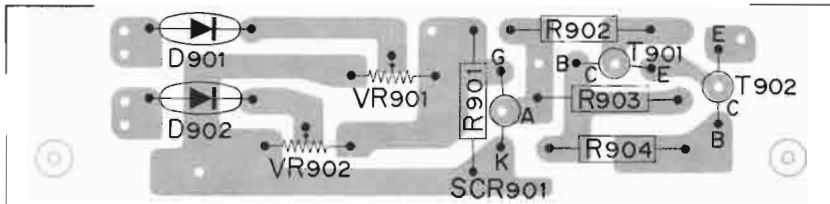
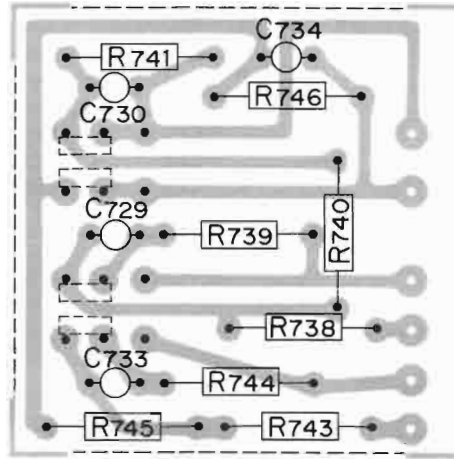

PROTECTOR F-1015

PARTS NAME

R902	VR901	SCR901
R903	VR902	
R904	TR901	D901
	TR902	D902

RIPPLE FILTER F-1018A

PARTS NAME

R001	R004	C005	C008	D004	TR001
R002	R005	C006	C009	D005	
R003	R006	C007	C010	Z001	

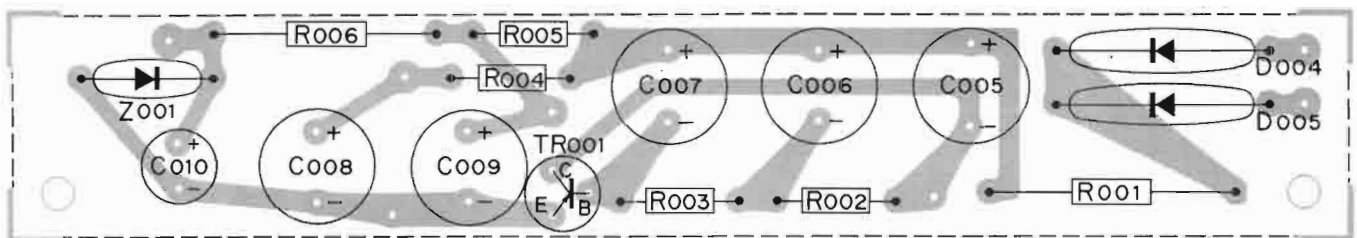

ACCESSORY CIRCUIT S-001B

PARTS NAME

R737	C728
R742	C731
C727	C732

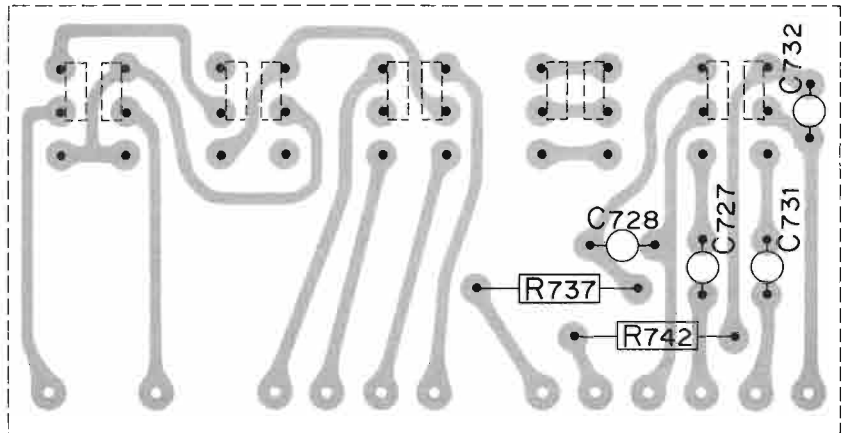

DIODES STACK F-1021A

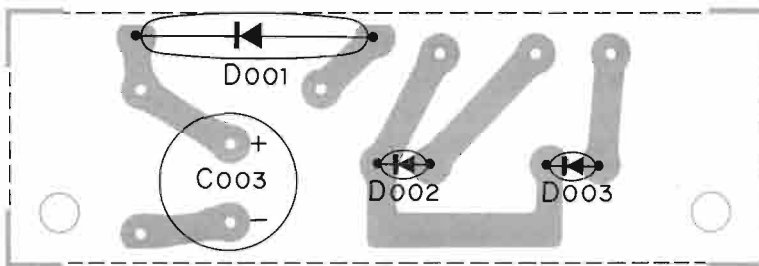

PARTS NAME

C003
D001
D002
D003

PARTS LIST

DESIGNATORS

C	Capacitor
CR	Capacitor-resistor modulated parts
D	Diode
F	Fuse
L	Inductor
M	Meter
NL	Neon lamp
PL	Pilot lamp
PU	Line voltage controller
R	Resistor
RLY	Relay
S	Switch
SCR	Silicon controlled rectifier
T	Transformer
TC	Trimmer capacitor
TH	Thermistor
T-P	Test point
TR	Transistor
V	Vacuum tube
VC	Variable capacitor
VR	Variable resistor

ABBREVIATIONS

(A)	A type taper
(B)	B type taper
(BH)	BH type taper
(C)	C type taper
CER.	Ceramic capacitor
COMP.	Composition
Hz	Cycle per second
ELECT.	Electrolytic
f	Farad
FET	Field effect transistor
Ge	Germanium
GND	Ground (ed)
H	Henry
Ins	Insulation (ed)
K	Kilo, 10 ³
m	Milli, 10 ⁻³
mA	Milli ampere(s), 10 ⁻³ ampere(s)
Mc.	Mica
M	Meg, 10 ⁶
MET. FLM.	Metal film
μ	Micro, 10 ⁻⁶
My.	Mylar ® ® Dupont de Nemours
Ne	Neon
Ω	ohm(s)
PC	Printed circuit
P	Pico: μμ: 10 ⁻¹²
Pos	Position(s)
Poly	Polystyrene
Pot	Potentiometer
PREC.	Precision (temperature coefficient, long term stability, and/or tolerance)
ROT	Rotary
Si	Silicon
SI	Slide
Ta.	Tantalum
Tog	Toggle
Tol	Tolerance
Trim	Trimmer
V	Volt(s)
VACW	Alternating current working volt(s)
VDCW.	Direct current working volt(s)
W	Watt
W/	With
W/O	Without
WW	Wire-wound

A: Parts No.
B: Parts Name
C: Co-ordinates in SCHEMATIC DIAGRAM
D: Co-ordinates in PARTS LAYOUT

A	B	C	D
R001	100Ω 5W ±10% Cementing Fixed	6 B	F-1018A
R002	560Ω ½W ±10% COMP. Fixed	6 B	F-1018A
R003	470Ω ½W ±10% COMP. Fixed	6 B	F-1018A
R004	560Ω ½W ±10% COMP. Fixed	6 B	F-1018A
R005	100Ω ½W ±10% COMP. Fixed	6 B	F-1018A
R006	270Ω 1W ±10% PREC. Fixed	6 B	F-1018A
R007	100Ω ½W ±10% COMP. Fixed	6 C	F-1018A
R008	1.2KΩ ½W ±10% COMP. Fixed	6 C	F-1018A
R101	100KΩ ¼W ±10% PREC. Fixed	1 A	F-1011
R102	1MΩ ¼W ±10% PREC. Fixed	1 A	F-1011
R103	120Ω ¼W ±10% PREC. Fixed	1 A	F-1011
R104	1KΩ ¼W ±10% PREC. Fixed	1 A	F-1011
R105	47KΩ ¼W ±10% PREC. Fixed	1 A	F-1011
R106	680Ω ¼W ±10% PREC. Fixed	1 A	F-1011
R107	8.2KΩ ¼W ±10% PREC. Fixed	1 B	F-1011
R108	2.2KΩ ¼W ±10% PREC. Fixed	1 B	F-1011
R109	1.8KΩ ¼W ±10% PREC. Fixed	1 B	F-1011
R110	8.2KΩ ¼W ±10% PREC. Fixed	1 B	F-1011
R111	3.3KΩ ¼W ±10% PREC. Fixed	1 B	F-1011
R112	1KΩ ¼W ±10% PREC. Fixed	1 B	F-1011
R113	120Ω ¼W ±10% PREC. Fixed	1 B	F-1011
R114	120Ω ¼W ±10% PREC. Fixed	1 B	F-1011
R115	2Ω ¼W ±10% PREC. Fixed	1 B	F-1011
R201	3.3KΩ ¼W ±10% PREC. Fixed	1 B	F-1014
R202	68KΩ ¼W ±10% PREC. Fixed	1 B	F-1014
R203	1KΩ ¼W ±10% PREC. Fixed	1 B	F-1014
R204	1KΩ ¼W ±10% PREC. Fixed	1 B	F-1014
R205	1KΩ ¼W ±10% PREC. Fixed	1 B	F-1014
R206	10KΩ ¼W ±10% PREC. Fixed	1 B	F-1014
R207	5.6KΩ ¼W ±10% PREC. Fixed	1 B	F-1014
R208	1.5KΩ ¼W ±10% PREC. Fixed	1 B	F-1014
R209	470Ω ¼W ±10% PREC. Fixed	1 B	F-1014
R210	5.6KΩ ¼W ±10% PREC. Fixed	1 C	F-1014
R211	8.2KΩ ¼W ±10% PREC. Fixed	1 C	F-1014
R212	22Ω ¼W ±10% PREC. Fixed	1 C	F-1014
R213	1KΩ ¼W ±10% PREC. Fixed	1 C	F-1014
R214	680Ω ¼W ±10% PREC. Fixed	1 C	F-1014
R215	22Ω ¼W ±10% PREC. Fixed	1 C	F-1014
R216	6.8KΩ ¼W ±10% PREC. Fixed	1 C	F-1014
R217	8.2KΩ ¼W ±10% PREC. Fixed	1 C	F-1014
R218	1KΩ ¼W ±10% PREC. Fixed	1 C	F-1014
R219	1KΩ ¼W ±10% PREC. Fixed	1 C	F-1014
R220	22Ω ¼W ±10% PREC. Fixed	1 C	F-1014
R221	10KΩ ¼W ±10% PREC. Fixed	1 C	F-1014
R222	1KΩ ¼W ±10% PREC. Fixed	1 C	F-1014
R223	1KΩ ¼W ±10% PREC. Fixed	1 C	F-1014
R224	22Ω ¼W ±10% PREC. Fixed	1 D	F-1014
R225	1KΩ ¼W ±10% PREC. Fixed	1 D	F-1014
R226	1KΩ ¼W ±10% PREC. Fixed	1 D	F-1014
R227	68Ω ¼W ±10% PREC. Fixed	1 D	F-1014
R228	10KΩ ¼W ±10% PREC. Fixed	1 D	F-1014
R229	10KΩ ¼W ±10% PREC. Fixed	1 D	F-1014
R230	1KΩ ¼W ±10% PREC. Fixed	1 C	F-1014
R231	10KΩ ¼W ±10% PREC. Fixed	1 C	F-1014
R232	22KΩ ¼W ±10% PREC. Fixed	1 C	F-1014
R233	22Ω ¼W ±10% PREC. Fixed	1 D	F-1014
R234	47KΩ ¼W ±10% PREC. Fixed	1 C	F-1014
R235	18KΩ ¼W ±10% PREC. Fixed	1 C	F-1014

A	B	C	D
R236	12KΩ ¼W ±10% PREC. Fixed	1 C	F-1014
R237	39KΩ ¼W ±10% PREC. Fixed	1 C	F-1014
R238	6.8KΩ ¼W ±10% PREC. Fixed	1 C	F-1014
R241	2.2KΩ ¼W ±10% PREC. Fixed	1 C	F-1014
R242	560KΩ ¼W ±10% PREC. Fixed	1 C	F-1014
R243	10KΩ ¼W ±10% PREC. Fixed	1 B	F-1014
R244	4.7KΩ ¼W ±10% PREC. Fixed	1 D	F-1014
R245	4.7KΩ ¼W ±10% PREC. Fixed	1 C	F-1014
R246	1KΩ ¼W ±10% PREC. Fixed	1 D	F-1014
R301	1KΩ ¼W ±10% PREC. Fixed	2 B	F-1014
R302	120Ω ¼W ±10% PREC. Fixed	2 C	F-1014
R303	4.7KΩ ¼W ±10% PREC. Fixed	2 B	F-1014
R304	22KΩ ¼W ±10% PREC. Fixed	2 B	F-1014
R305	1.5KΩ ¼W ±10% PREC. Fixed	2 B	F-1014
R306	100Ω ¼W ±10% PREC. Fixed	2 C	F-1014
R307	68KΩ ¼W ±10% PREC. Fixed	2 C	F-1014
R308	10KΩ ¼W ±10% PREC. Fixed	2 C	F-1014
R309	1KΩ ¼W ±10% PREC. Fixed	2 C	F-1014
R310	1KΩ ¼W ±10% PREC. Fixed	2 B	F-1014
R311	1KΩ ¼W ±10% PREC. Fixed	2 B	F-1014
R312	1KΩ ¼W ±10% PREC. Fixed	2 C	F-1014
R313	4.7KΩ ¼W ±10% PREC. Fixed	2 C	F-1014
R314	15KΩ ¼W ±10% PREC. Fixed	2 C	F-1014
R315	1KΩ ¼W ±10% PREC. Fixed	2 C	F-1014
R316	1KΩ ¼W ±10% PREC. Fixed	2 D	F-1014
R317	5.6KΩ ¼W ±10% PREC. Fixed	2 D	F-1014
R318	4.7KΩ ¼W ±10% PREC. Fixed	2 D	F-1014
R319	82KΩ ¼W ±10% PREC. Fixed	2 D	F-1014
R320	22KΩ ¼W ±10% PREC. Fixed	2 D	F-1014
R321	1KΩ ¼W ±10% PREC. Fixed	2 D	F-1014
R322	22Ω ¼W ±10% PREC. Fixed	2 B	4D
R323	1KΩ ¼W ±10% PREC. Fixed	2 C	4D
R324	47KΩ ¼W ±10% PREC. Fixed	2 C	8D
R401	47KΩ ¼W ±10% PREC. Fixed	3 A	F-1013
R402	100KΩ ¼W ±10% PREC. Fixed	3 A	F-1013
R403	220KΩ ¼W ±10% PREC. Fixed	3 A	F-1013
R404	3.3KΩ ¼W ±10% PREC. Fixed	3 A	F-1013
R405	1.5KΩ ¼W ±10% PREC. Fixed	3 A	F-1013
R406	27KΩ ¼W ±10% PREC. Fixed	3 A	F-1013
R407	270KΩ ¼W ±10% PREC. Fixed	3 A	F-1013
R408	22Ω ¼W ±10% PREC. Fixed	3 A	F-1013
R409	15KΩ ¼W ±10% PREC. Fixed	3 A	F-1013
R410	68KΩ ¼W ±10% PREC. Fixed	3 A	F-1013
R411	27KΩ ¼W ±10% PREC. Fixed	3 B	F-1013
R412	270KΩ ¼W ±10% PREC. Fixed	3 B	F-1013
R413	120KΩ ¼W ±10% PREC. Fixed	3 B	F-1013
R414	1.2KΩ ¼W ±10% PREC. Fixed	3 B	F-1013
R415	150KΩ ¼W ±10% PREC. Fixed	3 B	F-1013
R416	10KΩ ¼W ±10% PREC. Fixed	3 B	F-1013
R417	10KΩ ¼W ±10% PREC. Fixed	3 B	F-1013
R418	10KΩ ¼W ±10% PREC. Fixed	3 B	F-1013
R419	10KΩ ¼W ±10% PREC. Fixed	3 B	F-1013
R420	100KΩ ¼W ±10% PREC. Fixed	3 B	F-1013
R421	100KΩ ¼W ±10% PREC. Fixed	3 B	F-1013
R422	330KΩ ¼W ±10% PREC. Fixed	3 B	F-1013
R423	330KΩ ¼W ±10% PREC. Fixed	3 B	F-1013
R424	180KΩ ¼W ±10% PREC. Fixed	3 B	F-1013
R425	180KΩ ¼W ±10% PREC. Fixed	3 B	F-1013

PARTS LIST

A	B	C	D
R426	10KΩ ¼W ±10% PREC. Fixed	3 B	F-1013
R501	3.3KΩ ½W ±10% COMP. Fixed	2 C	TRI-1A
R502	1MΩ ½W ±10% COMP. Fixed	2 C	TRI-1A
R503	1KΩ ½W ±10% COMP. Fixed	2 C	TRI-1A
R504	39KΩ ½W ±10% COMP. Fixed	2 C	TRI-1A
R505	27KΩ ½W ±10% COMP. Fixed	2 C	TRI-1A
R506	10KΩ ½W ±10% COMP. Fixed	2 C	TRI-1A
R507	15KΩ ½W ±10% COMP. Fixed	2 C	TRI-1A
R508	8.2KΩ ½W ±10% COMP. Fixed	2 C	TRI-1A
R509	22KΩ ½W ±10% COMP. Fixed	2 C	TRI-1A
R510	3.3KΩ ½W ±10% COMP. Fixed	2 C	TRI-1A
R511	22KΩ ½W ±10% COMP. Fixed	2 C	TRI-1A
R512	390KΩ ½W ±10% COMP. Fixed	2 C	TRI-1A
R601	1KΩ ¼W ±10% PREC. Fixed	4 A	F-1037
R602	680Ω ¼W ±10% PREC. Fixed	4 A	F-1037
R603	47KΩ ¼W ±10% PREC. Fixed	4 A	F-1037
R604	100KΩ ¼W ±10% PREC. Fixed	4 A	F-1037
R605	1.8KΩ ¼W ±10% PREC. Fixed	4 A	F-1037
R606	470Ω ¼W ±10% PREC. Fixed	4 A	F-1037
R607	390KΩ ¼W ±10% PREC. Fixed	4 A	F-1037
R608	6.8KΩ ¼W ±10% PREC. Fixed	4 A	F-1037
R609	220Ω ¼W ±10% PREC. Fixed	4 A	F-1037
R610	680Ω ¼W ±10% PREC. Fixed	4 A	F-1037
R611	12KΩ ¼W ±10% PREC. Fixed	4 A	F-1037
R612	82KΩ ¼W ±10% PREC. Fixed	4 A	F-1037
R613	1MΩ ¼W ±10% PREC. Fixed	4 A	F-1037
R614	12KΩ ¼W ±10% PREC. Fixed	4 A	F-1037
R615	25KΩ ¼W ±10% PREC. Fixed	5 A	F-1037
R616	470KΩ ¼W ±10% PREC. Fixed	5 A	F-1037
R617	3.9KΩ ¼W ±10% PREC. Fixed	5 A	F-1037
R618	1KΩ ¼W ±10% PREC. Fixed	5 A	F-1037
R619	680KΩ ¼W ±10% PREC. Fixed	5 A	F-1037
R620	47KΩ ¼W ±10% PREC. Fixed	5 A	F-1037
R621	100KΩ ¼W ±10% PREC. Fixed	5 A	F-1037
R622	1.8KΩ ¼W ±10% PREC. Fixed	5 A	F-1037
R623	470Ω ¼W ±10% PREC. Fixed	5 A	F-1037
R624	390KΩ ¼W ±10% PREC. Fixed	5 A	F-1037
R625	6.8KΩ ¼W ±10% PREC. Fixed	5 A	F-1037
R626	220Ω ¼W ±10% PREC. Fixed	5 A	F-1037
R627	680Ω ¼W ±10% PREC. Fixed	5 A	F-1037
R628	12KΩ ¼W ±10% PREC. Fixed	5 A	F-1037
R629	82KΩ ¼W ±10% PREC. Fixed	5 A	F-1037
R630	1MΩ ¼W ±10% PREC. Fixed	5 A	F-1037
R631	12KΩ ¼W ±10% PREC. Fixed	5 A	F-1037
R632	25KΩ ¼W ±10% PREC. Fixed	5 A	F-1037
R633	470KΩ ¼W ±10% PREC. Fixed	5 A	F-1037
R634	3.9KΩ ¼W ±10% PREC. Fixed	5 A	F-1037
R635	68KΩ ¼W ±10% PREC. Fixed	5 A	F-1037
R636	100KΩ ¼W ±10% PREC. Fixed	4 A	8 D
R637	15KΩ ¼W ±10% PREC. Fixed	4 A	8 D
R638	100KΩ ¼W ±10% PREC. Fixed	4 A	4 A
R639	100KΩ ¼W ±10% PREC. Fixed	4 A	4 A
R640	470KΩ ¼W ±10% PREC. Fixed	4 A	4 A
R641	470KΩ ¼W ±10% PREC. Fixed	4 A	4 A
R642	100KΩ ¼W ±10% PREC. Fixed	4 A	4 A
R643	100KΩ ¼W ±10% PREC. Fixed	5 A	4 A
R644	68KΩ ¼W ±10% PREC. Fixed	5 A	8 A
R645	100KΩ ¼W ±10% PREC. Fixed	5 A	8 A

A	B	C	D
R646	15KΩ ¼W ±10% PREC. Fixed	5 A	8 A
R647	100KΩ ¼W ±10% PREC. Fixed	5 A	4 A
R701	1KΩ ½W ±10% COMP. Fixed	4 B	F-1016A
R702	47KΩ ½W ±10% COMP. Fixed	4 B	F-1016A
R703	68KΩ ½W ±10% COMP. Fixed	4 B	F-1016A
R704	100KΩ ½W ±10% COMP. Fixed	4 B	F-1016A
R705	1KΩ ½W ±10% COMP. Fixed	4 B	F-1016A
R706	3.3KΩ ½W ±10% COMP. Fixed	4 B	F-1016A
R707	120KΩ ½W ±10% COMP. Fixed	4 B	F-1016A
R708	15KΩ ½W ±10% COMP. Fixed	4 B	F-1016A
R709	2.7KΩ ½W ±10% COMP. Fixed	4 B	F-1016A
R710	10KΩ ½W ±10% COMP. Fixed	4 B	F-1016A
R711	6.8KΩ ½W ±10% COMP. Fixed	4 B	F-1016A
R712	22KΩ ½W ±10% COMP. Fixed	4 B	F-1016A
R713	10KΩ ½W ±10% COMP. Fixed	4 B	F-1016A
R714	6.8KΩ ½W ±10% COMP. Fixed	4 B	F-1016A
R715	47KΩ ½W ±10% COMP. Fixed	4 B	F-1016A
R716	470KΩ ½W ±10% COMP. Fixed	4 B	F-1016A
R717	5.6KΩ ½W ±10% COMP. Fixed	4 B	F-1016A
R718	1KΩ ½W ±10% COMP. Fixed	4 B	F-1016A
R719	1KΩ ½W ±10% COMP. Fixed	5 B	F-1016A
R720	47KΩ ½W ±10% COMP. Fixed	5 B	F-1016A
R721	68KΩ ½W ±10% COMP. Fixed	5 B	F-1016A
R722	100KΩ ½W ±10% COMP. Fixed	5 B	F-1016A
R723	1KΩ ½W ±10% COMP. Fixed	5 B	F-1016A
R724	3.3KΩ ½W ±10% COMP. Fixed	5 B	F-1016A
R725	120KΩ ½W ±10% COMP. Fixed	5 B	F-1016A
R726	15KΩ ½W ±10% COMP. Fixed	5 B	F-1016A
R727	2.7KΩ ½W ±10% COMP. Fixed	5 B	F-1016A
R728	10KΩ ½W ±10% COMP. Fixed	5 B	F-1016A
R729	6.8KΩ ½W ±10% COMP. Fixed	5 B	F-1016A
R730	22KΩ ½W ±10% COMP. Fixed	5 B	F-1016A
R731	10KΩ ½W ±10% COMP. Fixed	5 B	F-1016A
R732	6.8KΩ ½W ±10% COMP. Fixed	5 B	F-1016A
R733	47KΩ ½W ±10% COMP. Fixed	5 B	F-1016A
R734	470KΩ ½W ±10% COMP. Fixed	5 B	F-1016A
R735	5.6KΩ ½W ±10% COMP. Fixed	5 B	F-1016A
R736	1KΩ ½W ±10% COMP. Fixed	5 B	F-1016A
R737	27KΩ ½W ±10% COMP. Fixed	5 B	1 A
R738	2.2KΩ ½W ±10% COMP. Fixed	4 C	S-002A
R739	100KΩ ½W ±10% COMP. Fixed	4 C	S-002A
R740	2.2KΩ ½W ±10% COMP. Fixed	4 C	S-002A
R741	470KΩ ½W ±10% COMP. Fixed	4 C	S-002A
R742	27KΩ ½W ±10% COMP. Fixed	5 B	1 A
R743	2.2KΩ ½W ±10% COMP. Fixed	5 C	S-002A
R744	100KΩ ½W ±10% COMP. Fixed	5 C	S-002A
R745	2.2KΩ ½W ±10% COMP. Fixed	5 C	S-002A
R746	470KΩ ½W ±10% COMP. Fixed	5 C	S-002A
R747	150KΩ ½W ±10% COMP. Fixed	4 B	5 B
R748	150KΩ ½W ±10% COMP. Fixed	5 B	5 B
R801	2.2KΩ ½W ±10% COMP. Fixed	4 C	F-1001C
R802	150KΩ ½W ±10% COMP. Fixed	4 C	F-1001C
R803	560KΩ ½W ±10% COMP. Fixed	4 C	F-1001C
R804	220Ω ½W ±10% COMP. Fixed	4 C	F-1001C
R805	3.3KΩ ½W ±10% COMP. Fixed	4 C	F-1001C
R806	2.7KΩ ½W ±10% COMP. Fixed	4 C	F-1001C
R807	56KΩ ½W ±10% COMP. Fixed	4 C	F-1001C
R808	10KΩ ½W ±10% COMP. Fixed	4 C	F-1001C

A: Parts No.
B: Parts Name
C: Co-ordinates in SCHEMATIC DIAGRAM
D: Co-ordinates in PARTS LAYOUT

A	B	C	D	A	B	C	D
R809	22Ω ½W ±10% COMP. Fixed	4C	F-1001C	C102	15 pF ±0.5pF 50 VDCW. CER.	1A	F-1011
R810	15KΩ ½W ±10% COMP. Fixed	4C	F-1001C	C103	0.001μF $\begin{smallmatrix} +100 \\ -0 \end{smallmatrix}$ % 50 VDCW. CER.	1A	F-1011
R811	220Ω ½W ±10% COMP. Fixed	4C	F-1001C	C104	0.002μF $\begin{smallmatrix} +100 \\ -0 \end{smallmatrix}$ % 50 VDCW. CER.	1A	F-1011
R812	3.3KΩ ½W ±10% COMP. Fixed	4C	F-1001C	C105	0.001μF $\begin{smallmatrix} +100 \\ -0 \end{smallmatrix}$ % 50 VDCW. CER.	1A	F-1011
R813	1KΩ ½W ±10% COMP. Fixed	4C	F-1001C	C106	15 pF ±0.5pF 50 VDCW. CER.	1A	F-1011
R814	330Ω ½W ±10% COMP. Fixed	4C	F-1001C	C107	6 pF ±0.25pF 50 VDCW. CER.	1A	F-1011
R815	100Ω ½W ±10% COMP. Fixed	4C	F-1001C	C108	0.001μF $\begin{smallmatrix} +100 \\ -0 \end{smallmatrix}$ % 50 VDCW. CER.	1A	F-1011
R816	33Ω ½W ±10% COMP. Fixed	4C	F-1001C	C109	0.002μF $\begin{smallmatrix} +100 \\ -0 \end{smallmatrix}$ % 50 VDCW. CER.	1A	F-1011
R817	33Ω ½W ±10% COMP. Fixed	4C	F-1001C	C110	0.001μF $\begin{smallmatrix} +100 \\ -0 \end{smallmatrix}$ % 50 VDCW. CER.	1A	F-1011
R818	100Ω ½W ±10% COMP. Fixed	4C	F-1001C	C111	0.001μF $\begin{smallmatrix} +100 \\ -0 \end{smallmatrix}$ % 50 VDCW. CER.	1A	F-1011
R819	33Ω ½W ±10% COMP. Fixed	4C	F-1001C	C112	15 pF ±0.5pF 50 VDCW. CER.	1B	F-1011
R820	0.5Ω 3W ±10% WW	4D	4C	C113	5 pF ±0.5pF 50 VDCW. CER.	1B	F-1011
R821	0.5Ω 3W ±10% WW	4D	4C	C114	0.001μF $\begin{smallmatrix} +100 \\ -0 \end{smallmatrix}$ % 50 VDCW. CER.	1B	F-1011
R822	2.2KΩ ½W ±10% COMP. Fixed	5C	F-1001C	C115	20μF ±10% 50 VDCW. CER.	1B	F-1011
R823	150KΩ ½W ±10% COMP. Fixed	5C	F-1001C	C116	0.001μF $\begin{smallmatrix} +100 \\ -0 \end{smallmatrix}$ % 50 VDCW. CER.	1B	F-1011
R824	560KΩ ½W ±10% COMP. Fixed	5C	F-1001C	C117	120 pF ± 5% 50 VDCW. CER.	1B	F-1011
R825	220Ω ½W ±10% COMP. Fixed	5C	F-1001C	C118	0.001μF $\begin{smallmatrix} +100 \\ -0 \end{smallmatrix}$ % 50 VDCW. CER.	1B	F-1011
R826	3.3KΩ ½W ±10% COMP. Fixed	5C	F-1001C	C119	160 pF ± 5% 50 VDCW. CER.	1B	F-1011
R827	2.7KΩ ½W ±10% COMP. Fixed	5C	F-1001C	C120	220 pF ± 5% 50 VDCW. CER.	1B	F-1011
R828	56KΩ ½W ±10% COMP. Fixed	5C	F-1001C	C121	0.001μF $\begin{smallmatrix} +100 \\ -0 \end{smallmatrix}$ % 50 VDCW. CER.	1A	F-1011
R829	10KΩ ½W ±10% COMP. Fixed	5C	F-1001C	C122	5 pF ±10% 50 VDCW. CER.	1B	F-1011
R830	22Ω ½W ±10% COMP. Fixed	5C	F-1001C	C123	2 pF ±10% 50 VDCW. CER.	1B	F-1011
R831	15KΩ ½W ±10% COMP. Fixed	5C	F-1001C	C124	0.001μF $\begin{smallmatrix} +100 \\ -0 \end{smallmatrix}$ % 50 VDCW. CER.	1B	F-1011
R832	220Ω ½W ±10% COMP. Fixed	5C	F-1001C	C125	30 pF ±10% 50 VDCW. CER.	1B	F-1011
R833	3.3KΩ ½W ±10% COMP. Fixed	5C	F-1001C	C126	0.002μF $\begin{smallmatrix} +100 \\ -0 \end{smallmatrix}$ % 50 VDCW. CER.	1B	F-1011
R834	1KΩ ½W ±10% COMP. Fixed	5C	F-1001C	C127	15 pF ±10% 50 VDCW. CER.	1B	F-1011
R835	330Ω ½W ±10% COMP. Fixed	5C	F-1001C	C201	0.01μF $\begin{smallmatrix} +100 \\ -0 \end{smallmatrix}$ % 50 VDCW. CER.	1B	F-1014
R836	100Ω ½W ±10% COMP. Fixed	5C	F-1001C	C202	0.01μF $\begin{smallmatrix} +100 \\ -1 \end{smallmatrix}$ % 50 VDCW. CER.	1B	F-1014
R837	33Ω ½W ±10% COMP. Fixed	5C	F-1001C	C203	0.02μF $\begin{smallmatrix} +100 \\ -0 \end{smallmatrix}$ % 50 VDCW. CER.	1B	F-1014
R838	33Ω ½W ±10% COMP. Fixed	5C	F-1001C	C204	0.02μF $\begin{smallmatrix} +100 \\ -0 \end{smallmatrix}$ % 50 VDCW. CER.	1B	F-1014
R839	100Ω ½W ±10% COMP. Fixed	5C	F-1001C	C205	0.02μF $\begin{smallmatrix} +100 \\ -0 \end{smallmatrix}$ % 50 VDCW. CER.	1C	F-1014
R840	33Ω ½W ±10% COMP. Fixed	5C	F-1001C	C206	0.02μF $\begin{smallmatrix} +100 \\ -0 \end{smallmatrix}$ % 50 VDCW. CER.	1C	F-1014
R841	0.5Ω 3W ±10% WW	5D	4B	C207	0.02μF $\begin{smallmatrix} +100 \\ -0 \end{smallmatrix}$ % 50 VDCW. CER.	1C	F-1014
R842	0.5Ω 3W ±10% WW	5D	4B	C208	2 pF ±10% 50 VDCW. CER.	1C	F-1014
R843	470Ω 1W ±10% COMP. Fixed	4D	5A	C209	0.02μF $\begin{smallmatrix} +100 \\ -0 \end{smallmatrix}$ % 50 VDCW. CER.	1C	F-1014
R844	470Ω 1W ±10% COMP. Fixed	5D	5A	C210	0.02μF $\begin{smallmatrix} +100 \\ -0 \end{smallmatrix}$ % 50 VDCW. CER.	1C	F-1014
R845	330Ω ½W ±10% COMP. Fixed	4D	8B	C211	0.02μF $\begin{smallmatrix} +100 \\ -0 \end{smallmatrix}$ % 50 VDCW. CER.	1C	F-1014
R846	330Ω ½W ±10% COMP. Fixed	5D	8C	C212	0.02μF $\begin{smallmatrix} +100 \\ -0 \end{smallmatrix}$ % 50 VDCW. CER.	1C	F-1014
R902	6.8Ω ½W ±10% COMP. Fixed	6D	F-1015	C213	0.02μF $\begin{smallmatrix} +100 \\ -0 \end{smallmatrix}$ % 50 VDCW. CER.	1C	F-1014
R903	10Ω ½W ±10% COMP. Fixed	6D	F-1015	C214	0.02μF $\begin{smallmatrix} +100 \\ -0 \end{smallmatrix}$ % 50 VDCW. CER.	1C	F-1014
R904	10Ω ½W ±10% COMP. Fixed	6D	F-1015	C215	1μF 25 VDCW. ELECT.	1C	F-1014
R906	5.6KΩ ½W ±10% COMP. Fixed	6D	8C	C216	0.02μF $\begin{smallmatrix} +100 \\ -0 \end{smallmatrix}$ % 50 VDCW. CER.	1D	F-1014
R907	47KΩ ½W ±10% COMP. Fixed	6D	8C	C217	200 pF ±10% 50 VDCW. CER.	1D	F-1014
C001	0.033μF ±20% 600 VDCW. Oil	6A	8A	C218	200 pF ±10% 50 VDCW. CER.	1D	F-1014
C002	0.0047μF ±20% 600 VDCW. Oil	6A	8A	C219	10μF 10 VDCW. ELECT.	1D	F-1014
C003	1000μF 25 VDCW. ELECT.	6B	F-1021A	C220	50 pF ±10% 50 VDCW. CER.	1D	F-1014
C004	2000μF 75 VDCW. ELECT.	6B	7B	C223	0.02μF $\begin{smallmatrix} +100 \\ -0 \end{smallmatrix}$ % 50 VDCW. CER.	1C	F-1014
C005	200μF 50 VDCW. ELECT.	6B	F-1018				
C006	200μF 35 VDCW. ELECT.	6B	F-1018				
C007	200μF 35 VDCW. ELECT.	6B	F-1018				
C008	200μF 25 VDCW. ELECT.	6B	F-1018				
C009	200μF 25 VDCW. ELECT.	6B	F-1018				
C010	200μF 15 VDCW. ELECT.	6C	F-1018				
C011	0.02μF $\begin{smallmatrix} +100 \\ -0 \end{smallmatrix}$ % 50 VDCW. CER.	6C	8D				
C012	0.02μF $\begin{smallmatrix} +100 \\ -0 \end{smallmatrix}$ % 50 VDCW. CER.	6C	8D				
C101	100 pF ±20% 50 VDCW. CER.	1A	F-1011				

PARTS LIST

A	B	C	D
C224	0.02 μ F $\pm 100\%$	50 VDCW. CER.	1 D F-1014
C226	10 pF $\pm 10\%$	50 VDCW. CER.	1 C F-1014
C227	0.02 μ F $\pm 100\%$	50 VDCW. CER.	1 D F-1014
C228	0.02 μ F $\pm 100\%$	50 VDCW. CER.	1 C F-1014
C229	0.02 μ F $\pm 100\%$	50 VDCW. CER.	1 C F-1014
C230	0.02 μ F $\pm 100\%$	50 VDCW. CER.	1 C F-1014
C231	0.02 μ F $\pm 100\%$	50 VDCW. CER.	1 C F-1014
C233	0.02 μ F $\pm 100\%$	50 VDCW. CER.	1 C F-1014
C234	10 μ F	10 VDCW. ELECT.	1 B F-1014
C235	0.02 μ F $\pm 100\%$	50 VDCW. CER.	1 B F-1014
C236	0.02 μ F $\pm 100\%$	50 VDCW. CER.	1 B F-1014
C301	0.02 μ F $\pm 100\%$	50 VDCW. CER.	2 B F-1014
C302	0.02 μ F $\pm 100\%$	50 VDCW. CER.	2 B F-1014
C303	200 μ F	15 VDCW. ELECT.	2 B F-1014
C304	0.02 μ F $\pm 100\%$	50 VDCW. CER.	2 B F-1014
C305	0.02 μ F $\pm 100\%$	50 VDCW. CER.	2 B F-1014
C306	0.02 μ F $\pm 100\%$	50 VDCW. CER.	2 B F-1014
C307	430 pF $\pm 5\%$	50 VDCW. Mc.	2 C F-1014
C308	0.02 μ F $\pm 100\%$	50 VDCW. CER.	2 C F-1014
C309	10 μ F	15 VDCW. ELECT.	2 C F-1014
C310	0.02 μ F $\pm 100\%$	50 VDCW. CER.	2 C F-1014
C311	0.02 μ F $\pm 100\%$	50 VDCW. CER.	2 C F-1014
C312	0.02 μ F $\pm 100\%$	50 VDCW. CER.	2 C F-1014
C313	0.02 μ F $\pm 100\%$	50 VDCW. CER.	2 C F-1014
C314	200 μ F	15 VDCW. ELECT.	2 C F-1014
C315	0.01 μ F $\pm 100\%$	50 VDCW. CER.	2 D F-1014
C316	0.01 μ F $\pm 100\%$	50 VDCW. CER.	2 D F-1014
C317	0.02 μ F $\pm 100\%$	50 VDCW. CER.	2 D F-1014
C318	1 μ F	25 VDCW. ELECT.	2 D F-1014
C319	10 μ F	15 VDCW. ELECT.	2 D F-1014
C320	10 pF	15 VDCW. ELECT.	2 D F-1014
C321	200 μ F	15 VDCW. ELECT.	2 D F-1014
C323	0.02 μ F $\pm 100\%$	50 VDCW. CER.	2 B F-1014
C324	0.01 μ F $\pm 100\%$	50 VDCW. CER.	2 B F-1014
C325	1 pF $\pm 10\%$	50 VDCW. CER.	2 C F-1014
C327	10 pF $\pm 10\%$	50 VDCW. CER.	2 B F-1014
C328	0.02 μ F $\pm 100\%$	50 VDCW. CER.	2 B 4D
C329	0.2 μ F $\pm 10\%$	50 VDCW. My.	2 D 8D
C401	10 μ F	15 VDCW. ELECT.	3 A F-1013
C402	50 μ F	6 VDCW. ELECT.	3 A F-1013
C403	10 μ F	15 VDCW. ELECT.	3 A F-1013
C404	5000 pF $\pm 5\%$	50 VDCW. Mc.	3 A F-1013
C405	0.002 μ F $\pm 100\%$	50 VDCW. CER.	3 A F-1013
C406	1 μ F	25 VDCW. ELECT.	3 A F-1013
C407	450 pF $\pm 5\%$	50 VDCW. Mc.	3 A F-1013
C408	1 μ F	25 VDCW. ELECT.	3 A F-1013

A	B	C	D
C409	120 pF $\pm 5\%$	50 VDCW. Mc.	3 A F-1013
C410	6600 pF $\pm 5\%$	50 VDCW. Mc.	3 A F-1013
C411	0.05 μ F $\pm 10\%$	50 VDCW. My.	3 A F-1013
C412	1 μ F	25 VDCW. ELECT.	3 B F-1013
C413	1700 μ F $\pm 5\%$	50 VDCW. Mc.	3 B F-1013
C414	100 μ F $\pm 10\%$	50 VDCW. CER.	3 B F-1013
C415	100 μ F $\pm 10\%$	50 VDCW. CER.	3 B F-1013
C416	100 μ F $\pm 10\%$	50 VDCW. CER.	3 B F-1013
C417	100 pF $\pm 10\%$	50 VDCW. CER.	3 B F-1013
C419	750 pF $\pm 10\%$	50 VDCW. Mc.	3 B F-1013
C420	750 pF $\pm 10\%$	50 VDCW. Mc.	3 B F-1013
C421	50 pF $\pm 10\%$	50 VDCW. CER.	3 A F-1013
C422	0.01 μ F $\pm 10\%$	50 VDCW. My.	3 C 8D
C423	0.01 μ F $\pm 10\%$	50 VDCW. My.	3 C 8D
C501	0.1 μ F $\pm 10\%$	50 VDCW. My.	3 C TRI-1A
C502	5000 μ F $\pm 5\%$	50 VDCW. Mc.	3 C TRI-1A
C503	30 μ F	15 VDCW. ELECT.	3 C TRI-1A
C504	10 μ F	15 VDCW. ELECT.	3 C TRI-1A
C505	1 μ F	25 VDCW. ELECT.	3 C TRI-1A
C601	1.5 μ F	15 VDCW. Ta.	4 A F-1037
C602	150 pF $\pm 10\%$	50 VDCW. CER.	4 A F-1037
C603	30 μ F	6 VDCW. ELECT.	4 A F-1037
C604	30 μ F	6 VDCW. ELECT.	4 A F-1037
C605	150 pF $\pm 10\%$	50 VDCW. CER.	4 A F-1037
C606	50 μ F	6 VDCW. ELECT.	4 A F-1037
C607	10 μ F	25 VDCW. ELECT.	4 A F-1037
C608	0.004 μ F $\pm 10\%$	50 VDCW. My.	4 A F-1037
C609	0.01 μ F $\pm 10\%$	50 VDCW. My.	4 A F-1037
C610	0.003 μ F $\pm 10\%$	50 VDCW. My.	4 A F-1037
C611	1.5 μ F	15 VDCW. ELECT.	5 A F-1037
C612	150 pF $\pm 10\%$	50 VDCW. CER.	5 A F-1037
C613	30 μ F	6 VDCW. ELECT.	5 A F-1037
C614	30 μ F	6 VDCW. ELECT.	5 A F-1037
C615	150 pF $\pm 10\%$	50 VDCW. CER.	5 A F-1037
C616	50 μ F	6 VDCW. ELECT.	5 A F-1037
C617	10 μ F	25 VDCW. ELECT.	5 A F-1037
C618	0.004 μ F $\pm 10\%$	50 VDCW. My.	5 A F-1037
C619	0.01 μ F $\pm 10\%$	50 VDCW. My.	5 A F-1037
C620	0.003 μ F $\pm 10\%$	50 VDCW. My.	5 A F-1037
C621	100 pF $\pm 10\%$	50 VDCW. CER.	4 A F-1037
C622	5000 pF $\pm 10\%$	50 VDCW. CER.	5 A F-1037
C623	100 pF $\pm 10\%$	50 VDCW. CER.	5 A F-1037
C701	0.2 μ F $\pm 10\%$	50 VDCW. My.	4 B F-1016
C703	20 pF $\pm 10\%$	50 VDCW. CER.	4 B F-1016
C704	30 μ F	15 VDCW. ELECT.	4 B F-1016
C705	30 μ F	10 VDCW. ELECT.	4 B F-1016
C706	1 μ F	25 VDCW. ELECT.	4 B F-1016
C707	0.04 μ F $\pm 10\%$	50 VDCW. My.	4 B 5B
C708	0.04 μ F $\pm 10\%$	50 VDCW. My.	4 B 5B
C709	0.0015 μ F $\pm 10\%$	50 VDCW. My.	4 B F-1016A
C710	10 μ F	25 VDCW. ELECT.	4 B F-1016A
C711	100 pF $\pm 10\%$	50 VDCW. CER.	4 B F-1016A
C712	30 μ F	10 VDCW. ELECT.	4 B F-1016A
C713	1 μ F	25 VDCW. ELECT.	4 B F-1016A
C714	0.2 μ F $\pm 10\%$	50 VDCW. My.	4 B F-1016A
C716	20 pF $\pm 10\%$	50 VDCW. CER.	4 B F-1016A
C717	30 μ F	15 VDCW. ELECT.	4 B F-1016A
C718	30 μ F	10 VDCW. ELECT.	4 B F-1016A

- Trimmer attached to 4-gang variable capacitor
- ⊙ Trimmer attached to 3-gang variable capacitor
- 4-gang variable capacitor
- ⊙ 3-gang variable capacitor

- A: Parts No.
- B: Parts Name
- C: Co-ordinates in SCHEMATIC DIAGRAM
- D: Co-ordinates in PARTS LAYOUT

A	B	C	D
C719	1μF 25 VDCW. ELECT.	5B	F-1016A
C720	0.004μF ±10% 50 VDCW. My.	5B	5B
C721	0.004μF ±10% 50 VDCW. My.	5B	5B
C722	0.0015μF ±10% 50 VDCW. My.	5B	F-1016A
C723	10μF 25 VDCW. ELECT.	5B	F-1016A
C724	100pF ±10% 50 VDCW. CER.	5B	F-1016A
C725	30μF 10 VDCW. ELECT.	5B	F-1016A
C726	1μF 25 VDCW. ELECT.	5B	F-1016A
C727	150pF ±10% 50 VDCW. CER.	4B	1A
C728	0.02μF ±10% 50 VDCW. My.	4B	1A
C729	0.0025μF ±10% 50 VDCW. My.	4C	S-002A
C730	0.01μF ±10% 50 VDCW. My.	4C	S-002A
C731	150pF ±10% 50 VDCW. CER.	5B	1A
C732	0.02μF ±10% 50 VDCW. My.	5B	1A
C733	0.0025μF ±10% 50 VDCW. My.	5C	S-002A
C734	0.01μF ±10% 50 VDCW. My.	5C	S-002A
C801	0.05μF ±10% 50 VDCW. My.	4C	F-1001C
C802	50pF ±10% 50 VDCW. CER.	4C	F-1001C
C803	50μF 10 VDCW. ELECT.	4C	F-1001C
C804	5μF 25 VDCW. ELECT.	4C	F-1001C
C805	5μF 50 VDCW. ELECT.	4C	F-1001C
C806	0.05μF ±10% 50 VDCW. My.	4C	F-1001C
C807	50μF 10 VDCW. ELECT.	4C	F-1001C
C808	30μF 35 VDCW. ELECT.	4C	F-1001C
C809	300pF ±10% 50 VDCW. CER.	4C	F-1001C
C810	30μF 35 VDCW. ELECT.	4C	F-1001C
C811	2000μF 50 VDCW. ELECT.	4D	3. 4C
C812	0.5μF ±10% 50 VDCW. My.	5C	F-1001C
C813	50pF ±10% 50 VDCW. CER.	5C	F-1001C
C814	50μF 10 VDCW. ELECT.	5C	F-1001C
C815	5μF 25 VDCW. ELECT.	5C	F-1001C
C816	5μF 50 VDCW. ELECT.	5C	F-1001C
C817	0.05μF ±10% 50 VDCW. My.	5C	F-1001C
C818	50μF 10 VDCW. ELECT.	5C	F-1001C
C819	30μF 35 VDCW. ELECT.	5C	F-1001C
C820	300pF ±10% 50 VDCW. CER.	5C	F-1001C
C821	30μF 35 VDCW. ELECT.	5C	F-1001C
C822	2000μF 50 VDCW. ELECT.	5D	3. 4B
C901	0.5μF ±10% 50 VDCW. My.	6C	8C
CR401	38KC Filter & de-emphasis FP-38	3B	F-1013
CR402	38KC Filter & de-emphasis FP-38	3B	F-1013
VR201	5KΩ(B) Muting Adjust	1C	F-1014
VR202	50KΩ(B) FM Tuning Meter Adjust	1D	F-1014
VR301	10KΩ(B) AM Tuning Meter Adjust	2C	F-1014
VR501	50KΩ(B) Stereo indicator adjust	3C	TRI-1A
VR502	50KΩ(B) Stereo indicator adjust	3C	TRI-1A
VR601	5KΩ(B) MPX Separation	5A	8A
VR701		4B	5C
VR705	250KΩ(B) Balance control	5B	5C
VR702		4B	5D
VR706	250KΩ(BH) Main control	5B	5D
VR703		4B	5B
VR707	100KΩ(B) Bass control	5B	5B
VR704		4B	5C
VR708	100KΩ(B) Treble control	5B	5C
VR801	1MΩ(B) AC Balance adjust	4C	F-1001C
VR802	200Ω(B) Bias current adjust	4C	F-1001C

A	B	C	D
VR803	1MΩ(B) AC Balance adjust	5C	F-1001C
VR804	200Ω(B) Bias current adjust	5C	F-1001C
VR901	2KΩ(B) Protector adjust	6C	F-1015
VR902	2KΩ(B) Protector adjust	6C	F-1015
VC101	FM RF Tuning	1A	F-1011
VC102	FM RF Tuning	1A	F-1011
VC103	FM RF Tuning	1B	F-1011
VC104	FM local oscillator	1B	F-1011
VC301	AM RF Tuning 8~390pF	2B	2D
VC302	AM RF Tuning 8~390pF	2B	2D
VC303	AM local oscillator 8~390pF	2B	2D
TC101	2~8pF Trim	1A	F-1011
TC102	2~8pF Trim	1A	F-1011
TC103	2~8pF Trim	1A	F-1011
TC104	2~8pF Trim	1B	F-1011
TC301	2~15pF Trim	2B	2D
TC302	2~15pF Trim	2B	2D
TC303	2~15pF Trim	2B	2D
TR001	2SB-324 Ge P-N-P (030311)	6B	F-1018A
TR101	SE5050 Si N-P-N	1A	F-1011
TR102	SE3001 Si N-P-N	1B	F-1011
TR103	SE3001 Si N-P-N	1B	F-1011
TR201	2SC645 Si N-P-N (030523)	1B	F-1014
TR202	2SC645 Si N-P-N (030523-1)	1B	F-1014
TR203	2SC645 Si N-P-N (030523-1)	1C	F-1014
TR204	2SC645 Si N-P-N (030523-1)	1C	F-1014
TR205	2SC645 Si N-P-N (030523-1)	1C	F-1014
TR206	2SC645 Si N-P-N (030523)	1C	F-1014
TR207	2SC-828 Si N-P-N (030527)	1C	F-1014
TR208	2SC-828 Si N-P-N (030527)	1C	F-1014
TR301	2SA-102 Ge P-N-P (030004)	2B	F-1014
TR302	2SA-102 Ge P-N-P (030004)	2B	F-1014
TR303	2SA-101 Ge P-N-P (030005)	2C	F-1014
TR304	2SA-101 Ge P-N-P (030005-1)	2C	F-1014
TR305	2SC-536 Si N-P-N (030524-4)	2D	F-1014
TR401	2SC-536 Si N-P-N (030524-3)	3A	F-1013
TR402	2SC-536 Si N-P-N (030524-5)	3A	F-1013
TR403	2SC-536 Si N-P-N (030524-5)	3B	F-1013
TR501	2SC-458 Si N-P-N (030511)	3C	TRI-1A
TR502	2SC-458 Si N-P-N (030511)	3C	TRI-1A
TR503	2SB54 Ge P-N-P (030303)	3C	TRI-1A
TR504	2SC-458 Si N-P-N (030511)	3C	TRI-1A
TR505	2SB-325 Ge P-N-P (030311)	3C	TRI-1A
TR601	2SC-650 Si N-P-N (030510-4)	4A	F-1037
TR602	2SC458LGⓈ Si N-P-N (030531)	4A	F-1037
TR603	2SC-650 Si N-P-N (030510-4)	5A	F-1037
TR604	2SC458LGⓈ Si N-P-N (030531)	5A	F-1037
TR701	2SC-693 Si N-P-N (030517-1)	4B	F-1016A
TR702	2SC-536 Si N-P-N (030515-3)	4B	F-1016A
TR703	2SC-871(D) Si N-P-N (030547)	4B	F-1016A
TR704	2SC-693 Si N-P-N (030517-1)	5B	F-1016A
TR705	2SC-536 Si N-P-N (030515-3)	5B	F-1016A
TR706	2SC-871(D) Si N-P-N (030547)	5B	F-1016A
TR801	2SC-458LG(C) Si N-P-N (030531-1)	4C	F-1001C
TR802	2SC-826 Si N-P-N (030528)	4C	F-1001C

PARTS LIST

A : Parts No.
B : Parts Name
C : Co-ordinates in SCHEMATIC DIAGRAM
D : Co-ordinates in PARTS LAYOUT

A	B	C	D
TR803	2SC-708 Si N-P-N (030525)	4C	F-1001C
TR804	2SA-537 Si N-P-N (030006)	4C	F-1001C
TR805	2SC-493 Si N-P-N (030521)	4D	4C
TR806	2SC-493 Si N-P-N (030521)	4D	4C
TR807	2SC-458LG(C) Si N-P-N	5C	F-1001C
TR808	2SC-826 Si N-P-N (030528)	5C	F-1001C
TR809	2SC-708 Si N-P-N (030525)	5C	F-1001C
TR810	2SA-537 Si N-P-N (630006)	5C	F-1001C
TR811	2SC-493 Si N-P-N (030521)	5D	4A, B
TR812	2SC-493 Si N-P-N (030521)	5D	4B
FET101	MPP-102 Junction type	1A	F-1011
D001	10D-2 or SW-0501 Si diode Rectifier (031035)	6B	F-1021A
D002	SA-3Z or SA-2Z Si diode Rectifier (031042)	6B	F-1021A
D003	SA-3Z or SA-2Z Si diode Rectifier (031042)	6B	F-1021A
D004	10D-2 or SW-0502 Si diode Rectifier (031035)	6B	F-1018A
D005	10D-2 or SW-0502 Si diode Rectifier (031035)	6B	F-1018A
D201	IN-60 Ge diode FM detector (031033)	1D	F-1014
D202	IN-60 Ge diode FM detector (031033)	1D	F-1014
D203	IN-60 Ge diode AGC (031033)	1C	F-1014
D204	IN-60 Ge diode AGC (031033)	1C	F-1014
D206	IN-60 Ge diode Muting (031033)	1D	F-1014
D207	IN-60 Ge diode Muting (031033)	1D	F-1014
D208	IS-1209 or DS-410 Si diode Meter	1D	F-1014
D209	IN-60 Ge diode Meter (031033)	1D	F-1014
D301	IN-34A Ge diode AGC (031040)	2C	F-1014
D302	IN-34A Ge diode AM detector (031040)	2C	F-1014
D303	IN-34A Ge diode Meter (031040)	2C	F-1014
D401	IN-34A Ge diode 19KHz Rectifier (031040)	3A	F-1013
D402	IN-34A Ge diode 19KHz Rectifier (031040)	3A	F-1013
D403	IN-34A Ge diode Switching (031040)	3B	F-1013
D404	IN-34A Ge diode Switching (031040)	3B	F-1013
D405	IN-34A Ge diode Switching (031040)	3B	F-1013
D406	IN-34A Ge diode Switching (031040)	3B	F-1013
D501	OA-91(IN-60) Ge diode FM Indicator (031011)	3C	TRI-1A
D502	SM-150(10D-2) Si diode FM Indicator (031034)	3C	TRI-1A
D503	OA-91(IN-60) Ge diode FM Indicator (031011)	3C	TRI-1A
D801	IS-1209 or DS-410 Si diode (034003)	4C	F-1001C
D802	IS-1209 or DS-410 Si diode (034003)	4C	F-1001C
D803	IS-1209 or DS-410 Si diode (034003)	4C	F-1001C
D804	IS-1209 or DS-410 Si diode (034003)	4C	F-1001C
D805	IS-1209 or DS-410 Si diode (034003)	5C	F-1001C
D806	IS-1209 or DS-410 Si diode (034003)	5C	F-1001C
D807	IS-1209 or DS-410 Si diode (034003)	5C	F-1001C
D808	IS-1209 or DS-410 Si diode (034003)	5C	F-1001C
D901	IN-60 Ge diode (031033)	6C	F-1015
D902	IN-60 Ge diode (031033)	6C	F-1015

A	B	C	D
SCR901	2SF656 (035002)	6D	F-1615
Z001	ZR212 (031041)	6C	F-1018A
L101	FM RF coil	1A	F-1011
L102	FM RF coil	1A	F-1011
L103	FM RF coil	1A	F-1011
L104	FM IF coil	1B	F-1011
L105	FM OSC coil	1B	F-1011
L106	FM RF coil	1A	F-1011
L107	FM ANT coil	1A	4D
L301	AM ANT coil	2B	3C, D
L401	67KHz Filter 10 mH (424014)	3A	F-1013
L402	71KHz Filter 39 mH (424015)	3A	F-1013
T001	Power transformer 400-5285	6B	3, 4D
T201	FM IFT 10.7 MHz (423522)	1C	F-1014
T202	FM IFT 10.7 MHz (423524)	1C	F-1014
T203	FM IFT 10.7 MHz (423523)	1C	F-1014
T204	FM IFT 10.7 MHz (423525)	1D	F-1014
T205	FM IFT 10.7 MHz (423515)	1D	F-1014
T301	AM RF (421003)	2B	F-1014
T302	AM OSC (422004)	2C	F-1014
T303	AM IFT 455 KHz (423011)	2C	F-1014
T304	AM IFT 455 KHz (423012)	2C	F-1014
T305	AM IFT 455 KHz (423013)	2C	F-1014
T401	19KHz Tuning trap (424012)	3A	F-1013
T402	19KHz Tuning trap (424012)	3A	F-1013
T403	38KHz Tuning trap (424014)	3B	F-1013
T501	19KHz Tuning trap (424020)	3C	TRI-1A
S1(a~i)	Selector 110-1-5285		4A
S2(a~b)	Mode		1A
S3(a~b)	Mode		1A
S4(a~b)	Tape monitor		1A
S5(a~b)	Muting		1A
S6(a~b)	Loudness		1A
S7(a~b)	High filter		5B
S8(a~b)	Low filter		5B
S9(a~b)	Speaker selector 110-2-5285		5A
S10	AM attenuator		4D
S11	FM attenuator		1A
PL001	Tape indicator 8V 0.15A	6B	1C
PL002	Phono indicator 8V 0.15A	6B	1C
PL003	Dial indicator F type 6.3V 0.25A	6B	1D
PL004	Dial indicator F type 6.3V 0.25A	6B	1C
PL005	Dial indicator F type 6.3V 0.25A	6B	1B
PL006	Tuner indicator 8V 0.15A	6B	1D
PL007	AUX indicator 8V 0.15A	6B	1C
PL008	Power indicator 8V 0.15A	6B	1C
		6C	1B
F001	Power fuse 3A	6A	8B
F801	Quick acting fuse 2.5A	4D	8C
F802	Quick acting fuse 2.5A	5D	8C
S001	Power switch	6A	5A
M	Tuning meter 100μA	2D	1D

* All rights reserve specifications subject to change without notice.

COLOR CODE

The color code indicates 10 different colors by Using figures of 1 to 9. This code agrees with IEC and JIS.

Color	Common to All Parts			Fixed Resistor	Mica Capacitor				Paper Capacitor		Ceramic Capacitor			
	1st Figure	2nd Figure	Multiplier	Allowance (%)	Grade	Property	Allowance (%)	Rated Voltage (V)	Allowance (%)	Rated Voltage (V)	Grade	Property	Allowance (%)	Rated Voltage (V)
Black	0	0	1	±2	X	A	±20(M)	300	±20(M)	100	X		±20	
brown	1	1	10 ¹											
red	2	2	10 ²											
orange	3	3	10 ³											
yellow	4	4	10 ⁴											
green	5	5	10 ⁵											
blue	6	6	10 ⁶											
purple	7	7	10 ⁷											
grey	8	8	10 ⁸											
white	9	9	10 ⁹											
golden			10 ⁻¹	±5	Y		1000		±10(K)	1000	(Y)			
silver			10 ⁻²											
non-colored														
				±10								YY		
				±20								YZ		

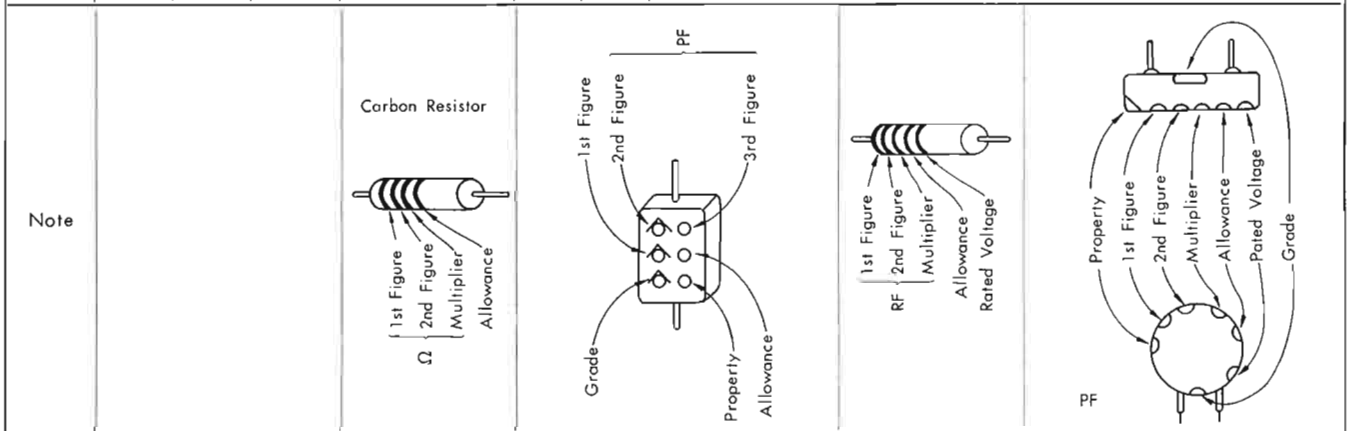

Property	Temperature Coefficient	Divergence of Capacity	Q tand	Insulation Resistance	Grade	Usable Temperature Range	Test Classification	Letter	Allowance
A	Not specified	Not specified	0.5 under	3000 MΩ under	X	-55 ~ +85	I or II	G	±2
B	Not specified	Not specified	0.5 over	7500 MΩ over but 0.1 over 3000 MΩ over	Y	-30 ~ +85	I or II	J	±5
C	-20 ~ +200	±(0.5% + 0.5pF)			Z	-30 ~ +85	I	K	±10
D	-100 ~ +100	±(0.3% + 0.1pF)			M				
E	-20 ~ +100	±(0.1% + 0.1pF)							
F	0 ~ +70	±(0.05% + 0.1pF)							



Sansui[®]



SANSUI ELECTRIC COMPANY LIMITED



Head Office; 14-1, 2-chome, Izumi, Suginami-ku, Tokyo, Japan. TEL. 323-1111

Printed in Japan (49001M2)

