

OPERATING INSTRUCTIONS & SERVICE MANUAL

SOLID-STATE AM/FM STEREO TUNER AMPLIFIER

SANSUI 300

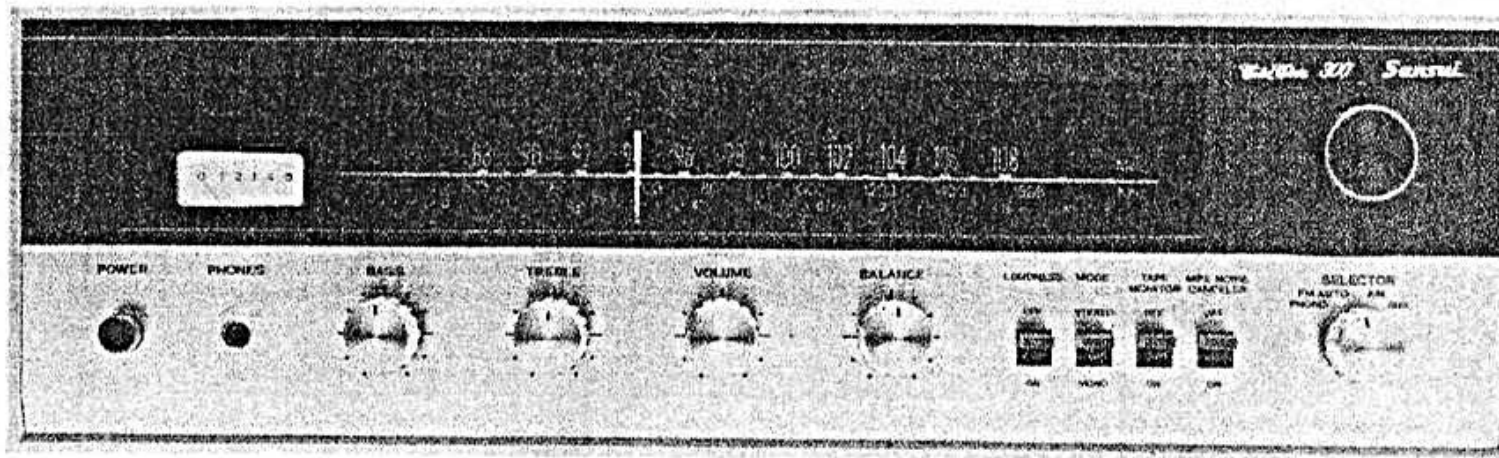

SANSUI ELECTRIC COMPANY LIMITED

In selecting the Sansui 300 AM/FM Stereo Tuner Amplifier, you have made a wise choice, one that will offer you years of quality stereo enjoyment.

Like all Sansui products, the 300 combines the finest in internal engineering, performance and design. It has been precision built, tested and re-tested to perform flawlessly within the limits of its specifications.

This manual has been prepared to help you keep the 300 in perfect operating conditions. It explains all of the 300's unique features, installation and playing procedures, as well as some basic maintenance requirements.

Please read the contents of this manual carefully before operating the receiver. You will then be better prepared to hear the 300 perform up to its full capabilities.

CONTENTS

SWITCHES AND CONTROLS	3, 4
OPERATION	5, 6
—SPEAKER CONNECTION	
—RECORD PLAYING	
OPERATION.....	7, 8
—ANTENNA CONNECTION	
—RADIO RECEPTION	
OPERATION	9, 10
—TAPE PLAYBACK	
—TAPE RECORDING	
MAINTENANCE	11, 12, 13
SPECIFICATIONS	14
TROUBLESHOOTING CHART	15, 16
DISASSEMBLE PROCEDURE/DIAL MECHANISM.....	17
BLOCK DIAGRAM	18
ALIGNMENT	
—TEST POINT.....	19
—FM ALIGNMENT PROCEDURE	20
—FM MULTIPLEX ALIGNMENT PROCEDURE.....	21
—AM ALIGNMENT PROCEDURE	22
PRINTED CIRCUIT BOARDS AND PARTS LIST	
.....	23, 24, 25, 26, 27, 28, 29
OTHER PARTS AND THEIR POSITION ON CHASSIS	
.....	29, 30

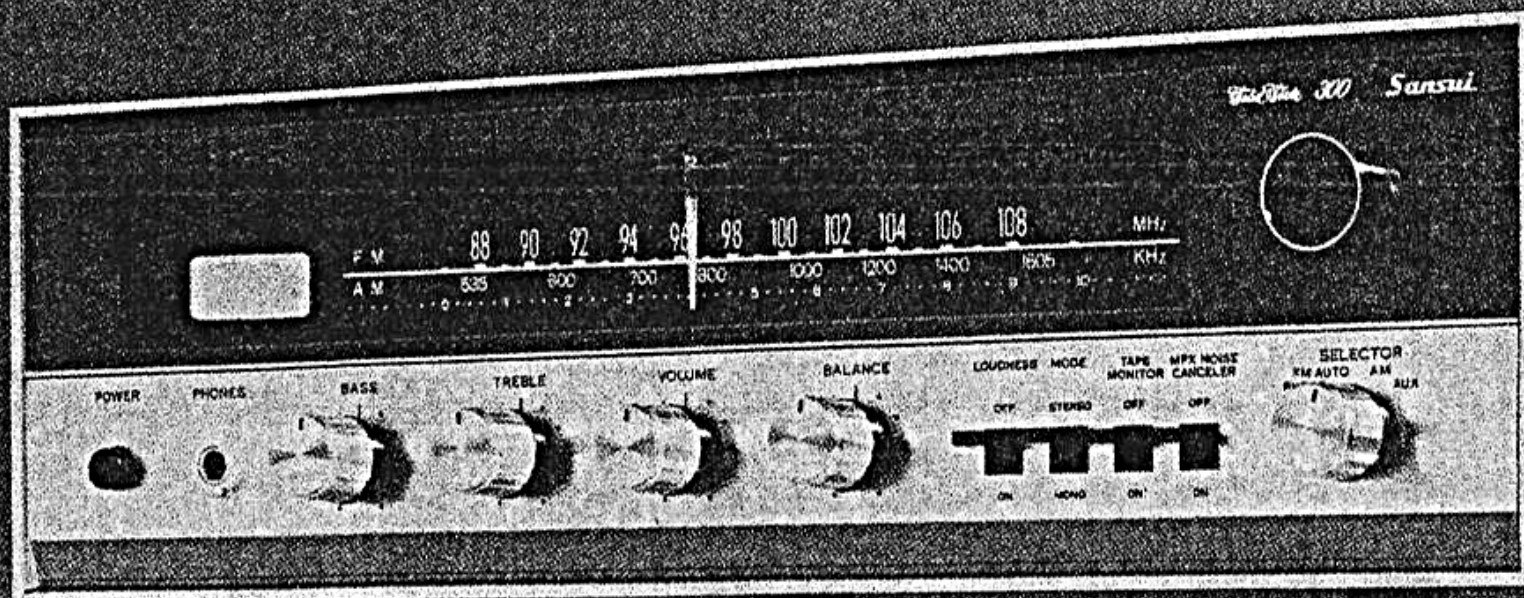

SWITCHES AND CONTROLS

Dial Scales

These scales are illuminated in green whenever the power is switched on and the SELECTOR switch is in either FM AUTO or AM position. The upper scale is for FM stations and the lower for AM. To select the desired station, turn the TUNING knob.

FM Stereo Indicator

This indicator is illuminated in green when an FM stereo program is received.

Tuning Meter

Indicates how well the receiver is tuned to the desired station. Pointer of this meter swings to the right as the dial pointer moves closer to the station's broadcasting frequency. The station, on either FM or AM band, is pinpointed when the pointer has swung as far to the right as it will go.

Power Switch

Connects and cuts power supply for the receiver. Push to turn it on, and push again to cut it off.

Headphones Jack

Insert a stereo headphone set into this jack to monitor a recorded tape or enjoy full stereo sound late at night without having to worry about disturbing other people. Sound from the speakers will be automatically cut off.

This jack will accept any standard phono plug, but a dynamic stereo headphones (Sansui SS-2) is recommended.

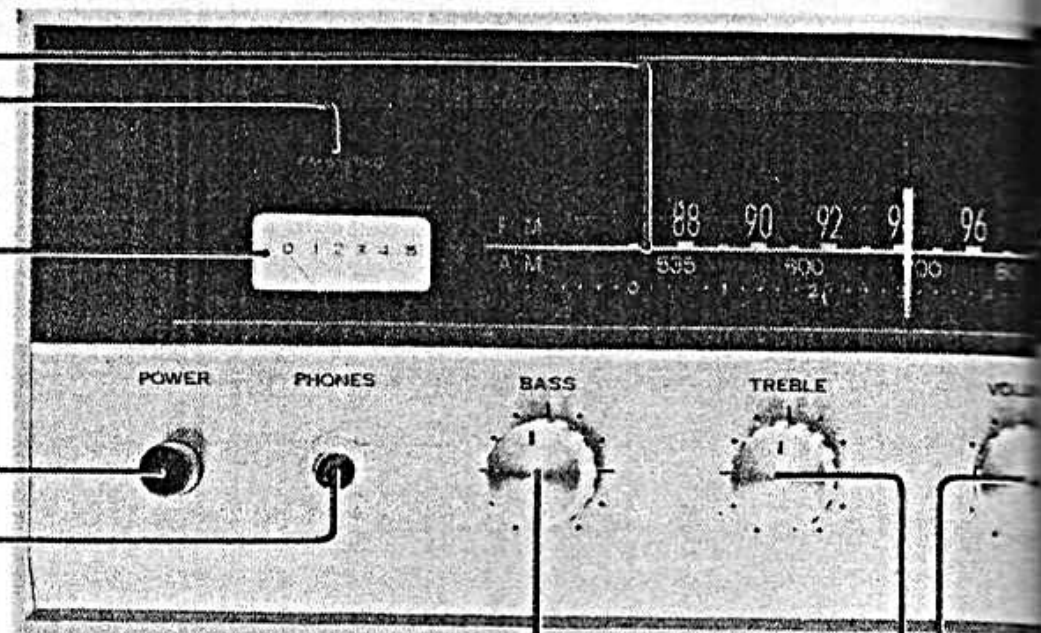

Bass Tone Control

Use to boost or reduce low-end frequency response. Turn it clockwise to boost, and counterclockwise to reduce. Center position gives a flat bass response.

Treble Tone Control

Use in the same manner as the BASS control to boost or reduce high-end frequency response.

Volume Control

Use to control the overall sound level of both channels. Turn clockwise to increase it, and counterclockwise to reduce it.

Balance Control

In stereo mode, balance the sound levels in the right and left channels with this control. Turn it so as to obtain equal sound volume from each channel while actually listening to a stereo material.

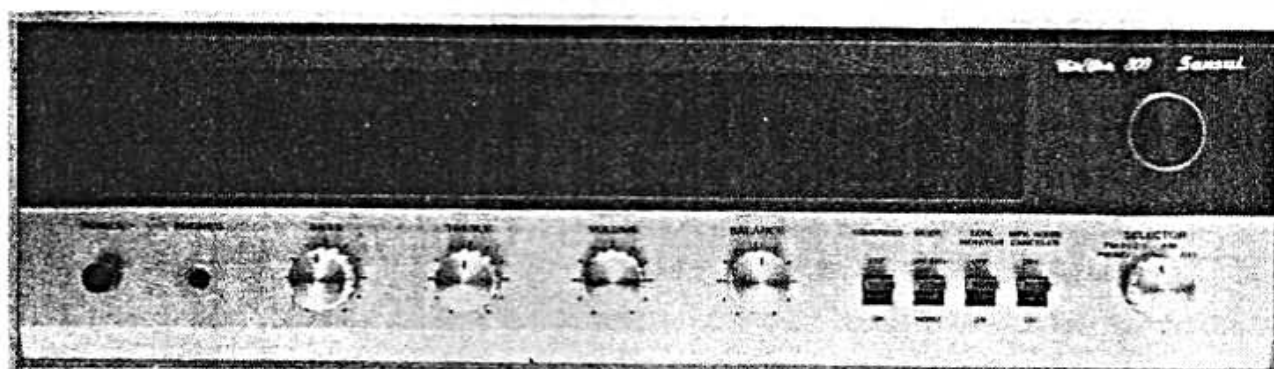

Tuning Knob

Tune in the desired broadcasting station by turning this knob, while watching the deflection of the tuning meter pointer.

Selector Switch

Select the desired program source with this switch.

PHONO—Turn to this position to hear records being played on a phonograph connected to PHONO input jacks on the rear.

FM AUTO—To hear FM broadcasts. In this position, the switch automatically selects the correct mode.

AM—To hear AM broadcasts.

AUX—To hear a component connected to AUX inputs on the rear.

MPX Noise Canceler

In the ON position, this switch eliminates or reduces noise accompanying FM multiplex programs transmitted by weak or distant stations.

Tape Monitor Switch

Turning this switch ON connects a tape monitor circuit in the receiver. Use it with a three-head tape recorder to monitor the tape which has just been recorded, or to play back a recorded tape on any tape recorder.

Be sure to keep it in OFF position for all other program sources, such as radio broadcasts and records. Otherwise, no sound will be heard from speakers.

Mode Switch

Switches between stereophonic and monophonic modes.

STEREO—Keep the switch in this position to hear FM MPX stereo broadcasts, stereo records and tapes.

MONO—Turn it to MONO to hear monophonic program sources or monophonic rendition of stereo sources. With the switch in this position, both right and left speakers produce the same sound whether input signals are fed to only one channel or both channels.

Loudness Switch

Turn this switch ON, and both bass and treble responses will be emphasized. Use it to compensate for the apparent loss of such responses at low listening levels and obtain powerful, lifelike stereo sound.

OPERATION

— SPEAKER CONNECTION — RECORD PLAYING

Speaker Connections

Connect a pair of speakers to the SPEAKERS terminals on the rear of the 300 in this manner:

1. Connect the speaker on your left (as viewed from the listening area) to the red LEFT (+) terminal.
2. Connect the lead from the common terminal of the left channel speaker (marked — or C) to the black LEFT (—) terminal.
3. Connect the right channel speaker to the red RIGHT (+) terminal.
4. Connect the lead from the common terminal of the right channel speaker to the black RIGHT (—) terminal.

To connect to the terminals:

1. Depress the colored terminal button.
2. Push the stripped end of the lead wire in the hole as shown on Page 6.
3. Release the button.

After connecting, make sure the wires are not shorted between the terminals. If shorted, the quick-acting fuse blows out and the amplifier becomes off.

If Speaker Polarities Are Not Matched....

You have connected the speakers. You are anxious to hear dynamic stereo sound; you turn the receiver on, set it in the desired mode and wait. What you hear disappoints you, however. It is as if sound is missing at both ends and in the center; you don't sense the continuity between the right and left speakers. The strong feeling of direction unique to true stereo sound is lacking. The heaviness of bass sound may be absent, too. In a word, sound is not natural.

If you experience such a phenomenon, it is because the polarities (+ and —) of the speakers are not matched with those of the receiver. The disappointing phenomenon described above is particularly conspicuous when the receiver is operating in the monophonic mode. If you suspect you have such

trouble when hearing an FM monophonic broadcast, for example, examine the speaker connections once. The unmatched polarities can be matched very simply by reversing the (+) and (—) connections of either speaker. Once they are matched, two speakers reproducing a monophonic material will sound as if there were only one speaker in the center.

Impedance of Speakers

Speakers of any make with impedance of 4 to 16 Ω may be hooked to the 300, with the following reservations:

1. Do not connect a pair of 4 Ω speakers in parallel to either right or left channel.
2. Do not connect more than one speaker of any impedance to either channel.
3. Do not connect speakers with other than specified impedance.

Failure to observe any of the above cautions may cause the quick-acting fuses to blow or distort the sound.

RECORD PLAYER

Connecting a Record Player

A record player or turntable using a 2~10mV magnetic cartridge with a built-in transformer is recommended for use with the 300.

1. Connect the left channel output of the player to the LEFT PHONO input on the rear of the amplifier.
2. Connect the right channel output of the player to the RIGHT PHONO input.
3. If a monophonic player or turntable is used, it may be connected to either LEFT or RIGHT PHONO jack.

NOTE: Although it is not recommended from a standpoint of tone quality, if a player with a crystal cartridge must be used, connect the output(s) of the player to the AUX jack(s) on the rear of the amplifier.

Playing a Record

1. Set the SELECTOR to PHONO.
2. Set the MODE switch to MONO if a monophonic phonograph is to be used, or to STEREO if a stereo phonograph is to be used.
3. Turn on power for the phonograph, and select the correct speed.
4. Balance the sound levels in the right and left channels with the BALANCE knob.
5. Use other controls and switches to suit taste and room acoustics.

NOTE:

1. If a monophonic record is to be played on a stereo phonograph, operate the receiver exactly in the same way for a stereo record for better results.
2. The balance of the sound levels in the right and left channels is most easily adjusted by playing a monophonic record through the receiver in the same way as a stereo record. Adjust it so that the two speakers will sound as if there were only one speaker in the center. To actually adjust, turn the BALANCE knob to the right or left until the sound is correctly centered.

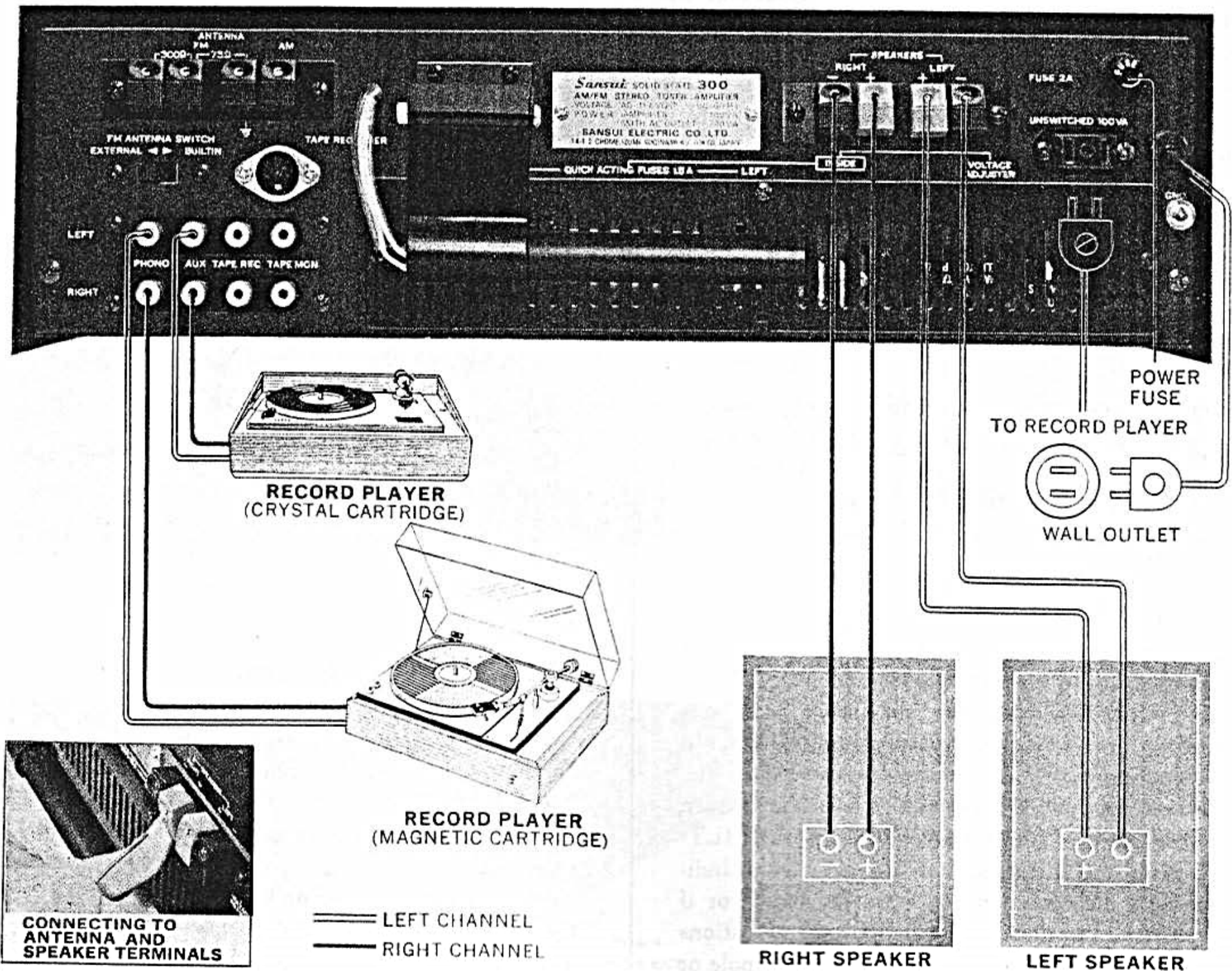

OPERATION

— ANTENNA CONNECTION

— RADIO RECEPTION

ANTENNA CONNECTIONS

The efficiency of antennas greatly affects the quality of radio reception. To enjoy noise-free reception, use antennas as described below.

Built-in AM Ferrite Bar Antenna

A highly sensitive ferrite bar antenna is attached on the rear panel of the 300 to receive AM broadcasts. To use, pull it up and away from the receiver. Except in weak signal areas remote from broadcast stations or inside ferroconcrete buildings, it should provide quality reception of those broadcasts.

Outdoor AM Antenna

In weak signal areas distant from broadcast stations or inside ferroconcrete buildings, the built-in ferrite bar antenna alone may fail to provide good reception of AM broadcasts. If this is the case, connect the PVC wire accompanying the receiver to the antenna terminal marked AM on the rear panel. Then run this wire outdoors and set it up as an antenna a little distance away from the buildings. For better results, ground the antenna terminal button with a symbol indicating ground, also on the rear panel, at the same time. As the sensitivity of an outdoor antenna varies greatly with its position, install it in the position which affords the best reception. For reasons of safety, it should be outfitted with a lightning arrester.

FM Antennas

With the 300, one of the four antenna systems can be used: (1) the built-in antenna, (2) the indoor dipole supplied with the 300, (3) a 300-ohm outdoor antenna, or (4) a 75-ohm coaxial cable.

The built-in FM antenna can pick up stations clearly in urban or high intensity signal areas. In this system, the speaker cable connected to the 300 is used as an FM antenna. To use, simply turn the rear FM ANTENNA SWITCH to its BUILT-IN position. If the maximum signal strength indicated by the tuning meter is not satisfactory, or if the 300 cannot pull in the desired distant stations clearly, it is necessary to install the indoor dipole or

outdoor antenna.

In strong signal areas, the folded dipole antenna (supplied) is adequate for FM reception. Connect it to the antenna terminals marked FM 300 Ω on the rear panel of the amplifier, then open it to a full "T", and tack to a wall or ceiling where it allows the best signal reception.

In area remote from broadcast stations or inside ferroconcrete buildings where signal intensity is low, the folded dipole antenna alone may not supply sufficient signal inputs. An exclusive outdoor antenna for the FM band then becomes necessary just as for a television receiver. Two types of outdoor FM antennas, 300 Ω balanced and 75 Ω unbalanced, are commercially available. The usual choice is the 300 Ω balanced type. On the receiver side, the feeder wire of this antenna is connected to the 300 Ω FM antenna terminals. Where the 75 Ω unbalanced type is used and wired through a distributor, the conductor of its coaxial cable should be connected to the left terminal button of the two 75 Ω FM antenna terminal buttons, and its shielding wire to the right one (with a symbol indicating ground).

The farther you live from broadcasting stations, the greater difference the choice and positioning of an outdoor FM antenna makes in the quality of reception. The properties of FM broadcast signals are such that merely extending the length of the antenna does not increase sensitivity. What is more important is its direction and height, which should be determined so as to afford the best reception while actually listening to a broadcast.

FM Radio Reception.

1. Turn the SELECTOR to FM AUTO.
2. Set the MODE switch to STEREO.
3. Push the POWER switch on and the dial scales are illuminated in green.
4. Select the desired station on the FM tuning dial scale with the Tuning Knob, while watching the Tuning Meter. The station is correctly tuned when the Tuning Meter pointer swings to the right as far as it will go.

5. Operate all other controls and switches to suit taste and room acoustics.

AM Radio Reception

1. Turn the SELECTOR to AM.
2. Set the MODE switch in either MONO or STEREO position.

3. Push the POWER switch on and the dial scales are illuminated in green.

4. Tune in the desired station by turning the Tuning Knob for the maximum deflection of the Tuning Meter pointer.

5. Use all other controls and switches to suit taste and room acoustics.

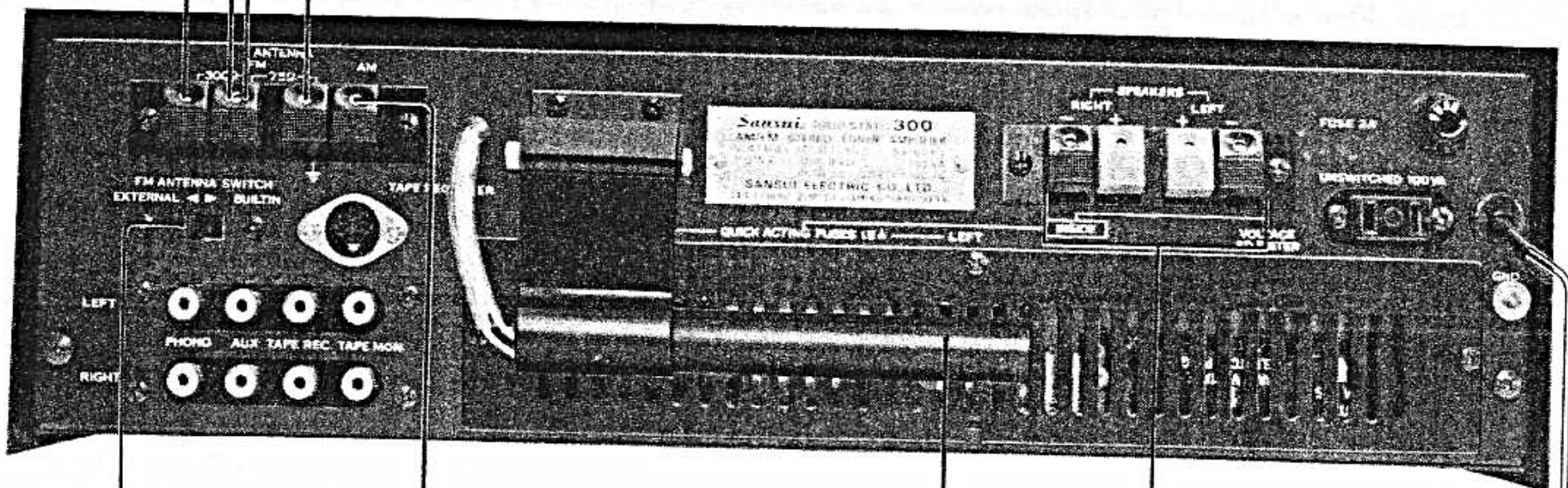
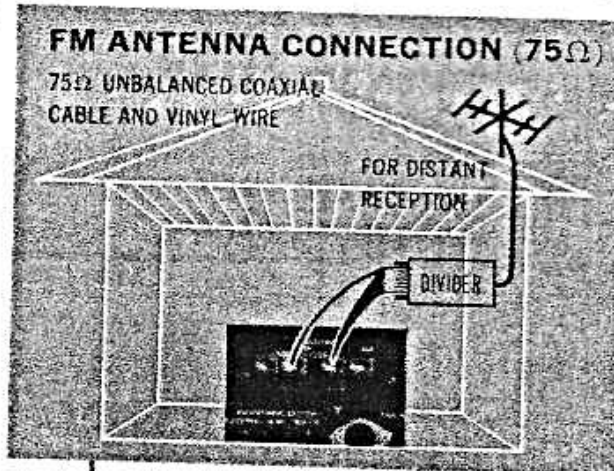
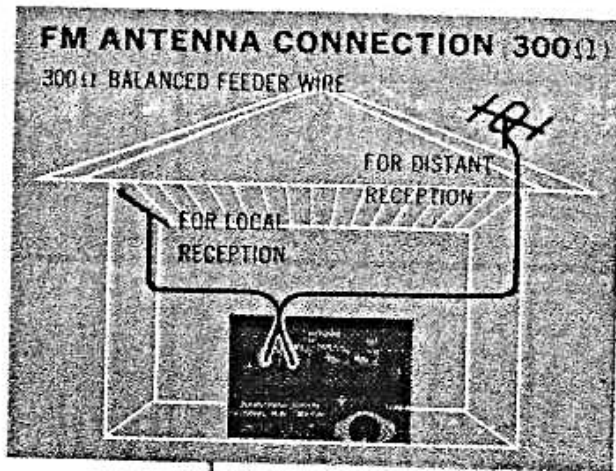

FM ANTENNA SWITCH

SEE "SPEAKER CONNECTIONS"

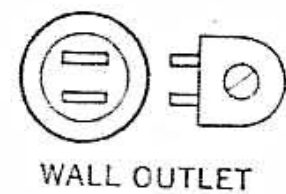
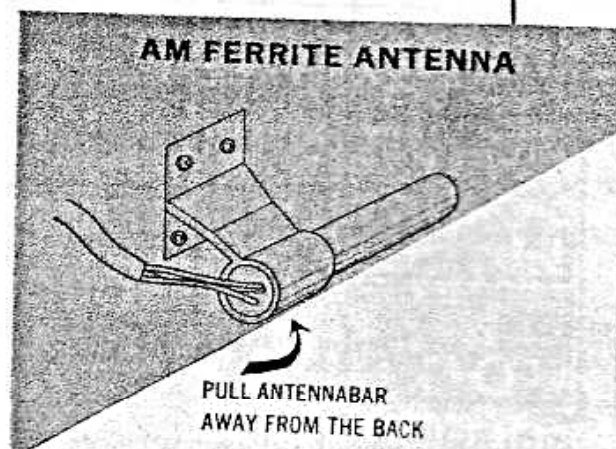
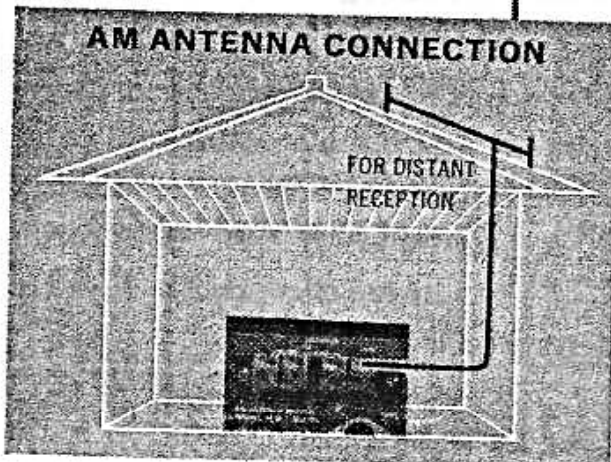

OPERATIONS

— TAPE PLAYBACK

— TAPE RECORDING

TAPE RECORDERS

Tape recorders can be connected to record from, and playback through, the amplifier. But a tape deck cannot be used with the 300. For use with a tape recorder having its own playback preamplifier as well as separate recording and playback heads, the 300 can compare the recorded tape with the program source.

Connecting a Tape Recorder with a DIN Connector Cable

If the DIN connector cable is not yet connected to your tape recorder, insert the DIN connector at one of its ends into the DIN socket on the recorder first; then, insert the one on the other end into a similar socket marked TAPE RECORDER on the rear of the 300. The DIN connection system, based on the German DIN Standards and designed to simplify interconnections between the tape recorder and amplifier, enables tape recording and playback merely by plugging a cable with 5-pin connectors into their respective sockets.

Connecting a Tape Recorder with Pin Plug Cables

If your tape recorder lacks the DIN socket and only has pin jacks, connect it to the 300 with two pairs of shielded cables having a pin plug on each end, as follows:

To Record—Connect the right and left channel input jacks of the recorder to the RIGHT and LEFT TAPE REC. jacks on the rear of the 300 with a pair of such cables. If the recorder is a monophonic one, it may be connected to either right or left jack.

To Play—Connect the right and left channel output jacks of the recorder to the RIGHT and LEFT TAPE MON. jacks with another pair of such cables. Again use only one jack for a monophonic tape recorder.

Tape Monitoring

To record a tape and monitor the recorded tape almost simultaneously, the recorder must be connected by the use of pin plug cables. The DIN connectors do not allow such operation.

NOTE:

- 1) The switches and controls on the receiver control only the sound from the speakers. They do not affect the signals at the receiver's tape recording terminals, which are therefore recorded in a flat state. Thus, to monitor the recorded tape for the purpose of checking on the quality of recording, keep the various switches and controls on the receiver neutral (flat).
- 2) Whenever possible, avoid recording from microphones placed in front of the speaker(s), as it will considerably impair the tone quality. Instead, feed the signals from the receiver's tape recording terminals direct into the input terminals of the recorder.
- 3) The machine referred to as a tape recorder in this section includes only that kind of tape recorder which contains a playback preamplifier.
- 4) Tape monitoring is possible only with a tape recorder having three heads (erase head, plus separate record and play heads).
- 5) Unless you are recording a tape and want to monitor it or playing back a recorded tape, be sure to keep the TAPE MONITOR switch in the OFF position.
- 6) A tape deck does not have a playback preamplifier, and its output is delivered direct from its playback head. So if you want to connect a tape deck to the 300, it is essential that you feed its output to a separate equalizer amplifier first before coupling it to the receiver. In contrast, the output of a tape recorder or tape player has already been passed through a playback preamplifier incorporating such an amplifier, and should be connected direct to the TAPE MON. terminals on the 300's rear panel. To hear it, do not forget to set the TAPE MONITOR switch to its ON position.

Recording with a Tape Recorder

To record a tape on a tape recorder:

1. Set the SELECTOR to the desired program source (either PHONO, FM AUTO, AM or AUX).
2. Set the MODE switch to either STEREO or MONO, depending on the type of tape recorder used.
3. Start the recorder in the recording mode.
4. Use other pertinent controls and switches on re-

ceiver, as required.

Playing a Recorded Tape

To play back a recorded tape on a tape recorder:

1. Set the TAPE MONITOR switch to its ON position.
2. Start the recorder in the playback mode.
3. Use all other pertinent controls and switches on the receiver to suit taste and room acoustics.

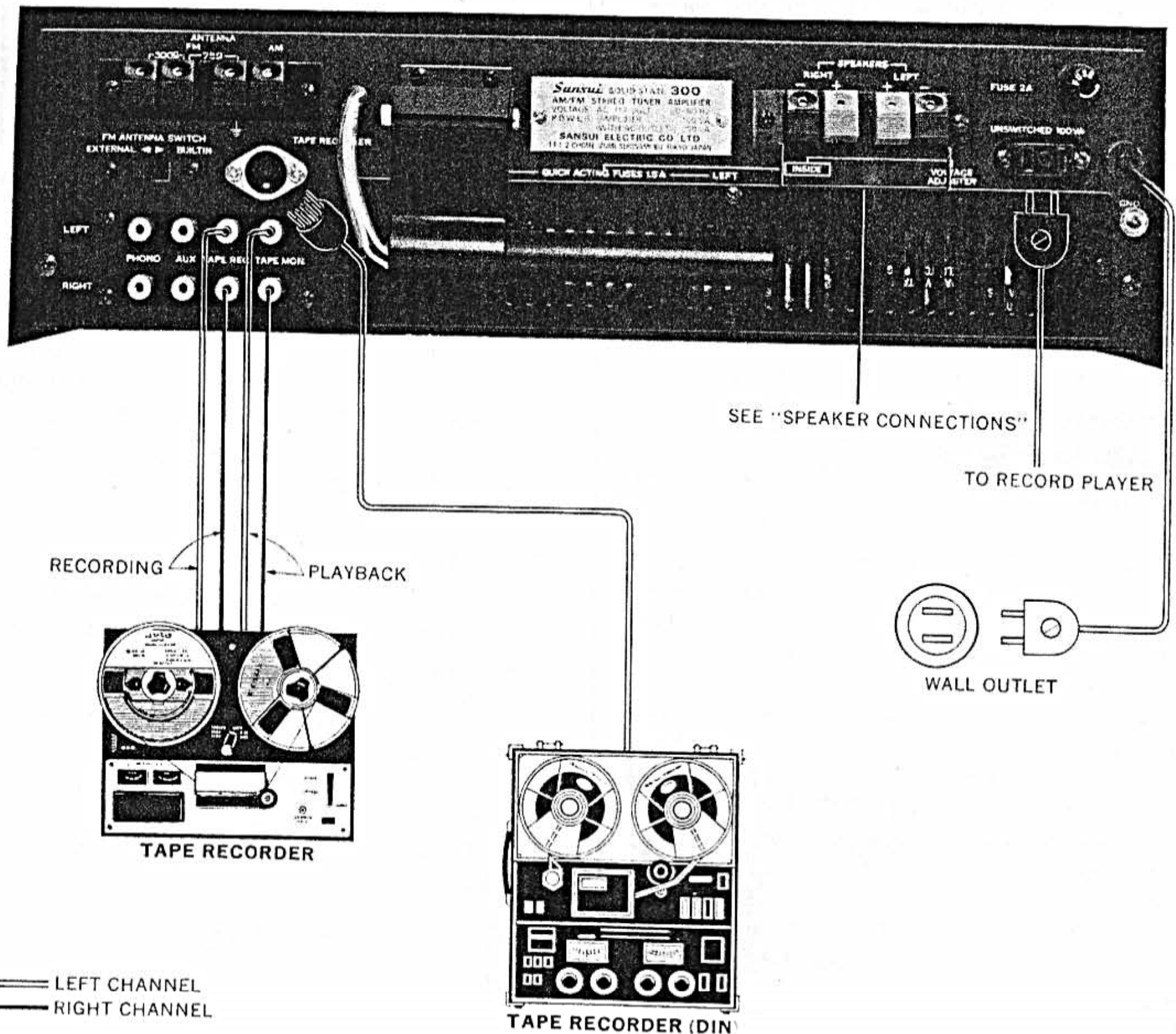

MAINTENANCE

How to Eliminate Unpleasant Noise on Broadcast Bands

AM Band:

If you live far from broadcast stations, in the mountains or in a valley where it is difficult for radio signals to reach, inside a ferroconcrete building, or in an area where a number of large ferroconcrete buildings are crowded together, your 300 as it is may fail to provide really clear, noise-free reception of AM broadcasts. This situation can be corrected to a great extent by connecting a PVC wire to the AM antenna terminal on the receiver's rear panel and spreading it along a wall or the ceiling of room. If this should fail to reduce noise sufficiently or give you satisfactory sensitivity, and especially if you live inside a ferroconcrete building, erect an outdoor antenna a short distance away from the wall of the building. Further, some types of noise may be heard only at certain hours of the day or with only certain broadcast stations. This is usually due to the unique properties of AM broadcast signals, and can often be remedied by grounding the receiver or reversing the inserted position of the power cord plug.

FM Band:

The noise that you may hear with FM broadcasts is generally attributable to two causes. It may be caused by insufficient signal inputs into the antenna, or it may be produced by external electrical appliances. To eliminate or reduce such noise, follow these directions:

- 1) The antenna cannot receive sufficient signal inputs if it is improperly positioned or if broadcast stations are very distant. If you are using the dipole feeder antenna which comes with the receiver as instructed on page 7 under **FM Antennas**, try changing its position and see if you can obtain better sensitivity and reduce noise.
- 2) If the above measure fails to cut noise drastically, try installing an indoor TV antenna for greater sensitivity, or, better yet, erect an exclusive FM antenna (or TV antenna) outdoors in the position

which gives you the best reception. If one antenna is to be shared both for TV and FM radio receptions through the use of a splitter, make certain the TV reception is not affected.

- 3) Merely extending the length of the antenna or spreading it around many corners may sometimes increase noise.

- 4) With FM broadcasts, the transmitting condition of each station (such as the efficiency of the station's output antenna) has a great bearing upon the sensitivity. This may result in a situation where station A is received quite clearly, but station B is barely audible.

Noise Persistent on All Bands:

Other types of noise than those described may be heard at certain hours of the day, especially in an area where a number of ferroconcrete buildings are crowded together. These are usually produced by electrical appliances in those buildings, and can be easily distinguished from the types of noise described above because of their relationship with the hours. The situation can be corrected if it is an electrical appliance in your own house that is producing the noise. Simply attach a noise suppressor to that appliance. Or attach it to the AC power source of the receiver itself.

Heat Dissipation

Transistors being relatively sensitive to heat, careful consideration has been given in designing the 300 to the efficiency of heat dissipation from the rear panel. For this reason, it is strongly recommended not to place anything on top of the receiver, encase it in a tightly closed box or operate it in direct sunlight. If either of these conditions cannot be avoided, take special care to increase the heat dissipation, or it may eventually lead to a breakdown.

Connection of External Components

To connect such external audio components as a

tape recorder or phonograph, be sure to use thick, shielded cables which distribute only a minimum capacitance. The use of ordinary lamp cord usually results in picking up hum.

The length of such cables should not exceed 6 or 7 feet. The longer they are, the more the high frequencies of the program is attenuated.

To connect a monophonic component, use either the right or left channel terminal, whichever is easier to connect.

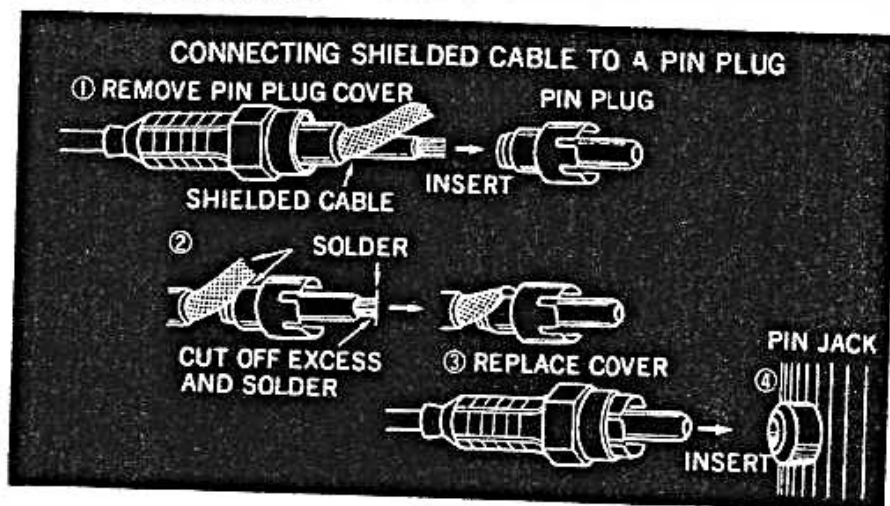

If Booming Noise is Heard When Playing a Record....

Unpleasant booming hum or howling noise may be heard when playing a record or a recorded tape. This is almost invariably due to one of these reasons:

- 1) If the phonograph is placed directly on a speaker enclosure or very close to it, the vibration of the speaker will be transmitted to the phonograph, resulting in a booming phenomenon called howling. This can be easily corrected by separating the phonograph away from the speaker or placing a thick cushion underneath the phonograph.
- 2) Booming noise is produced if the phonograph or tape recorder is connected with wires or cables other than shielded cables.
- 3) If neither of the above reasons applies, check the connections of various cables. Shielding wire and conductor of a shielded cable may be conversely soldered to a pin plug; the phonograph motor may not be grounded, or the grounding of its tonearm may be incomplete. In either case, unpleasant

booming noise could result.

Grounding

Connect one end of a piece of PVC wire or enameled wire to the antenna terminal with a symbol indicating grounding, attach a small copper plate or bar to the other end and bury it deep under the ground. Whenever an external antenna is attached to the receiver, the receiver should be grounded in this manner.

Or also, it may be grounded by the use of the "GND" terminal. Attach a piece of PVC wire to it and bury it underground in the manner described above. This usually helps to prevent the audio amplifier from picking up noise, and also considerably cuts down noise on the broadcast bands.

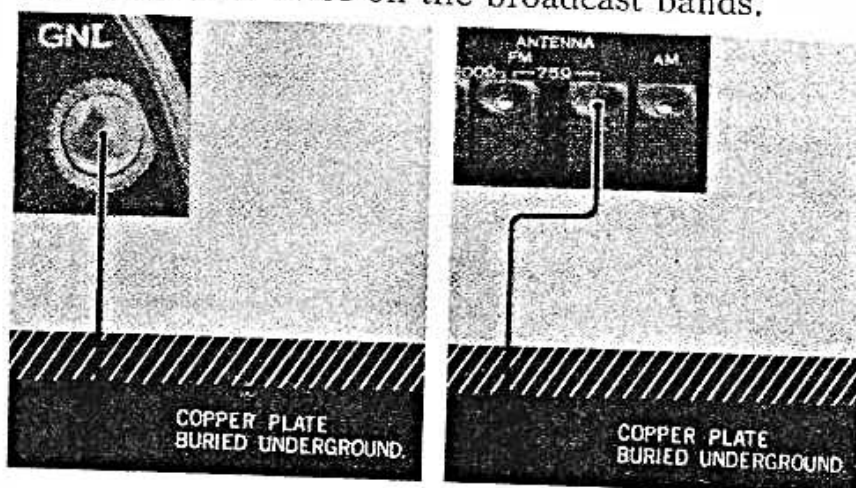

AC Outlet

One AC outlet is provided on the receiver's rear panel, and can be used like any other outlet for AC house current. Plug a phonograph or tape recorder into this outlet for power supply.

The outlet has a maximum capacity of 100VA, and is not controlled by the POWER switch on the receiver's front panel.

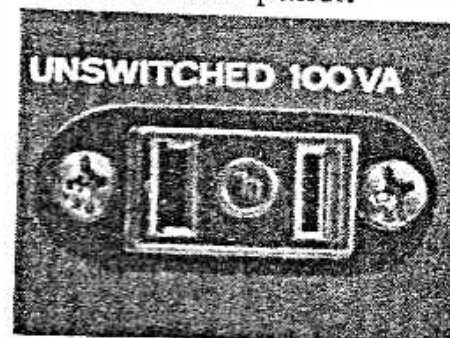

MAINTENANCE

Voltage Adjustment

The Voltage Adjustor on the rear of the chassis enables you to operate the 300 at correct voltage in any areas. The voltage has been pre-adjusted at the factory, but can be easily readjusted as follows:

STEP I Set arrow of main voltage selector plug to required voltage: 100, 110, 117, 127, 220, 230, 240 or 250 volts.

STEP II If numerals of voltage are printed in red, set arrow of adjacent sub V.S. plug to position marked red. If they are printed in white, set arrow to position marked white.

NOTE: The Voltage Adjustor can be used to eliminate the trouble caused by the considerable voltage fluctuation. In this case, it should be set to the peak voltage.

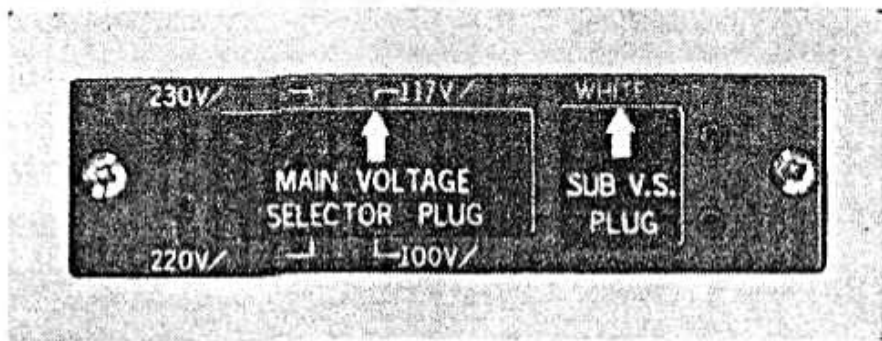

Should the Power Fuse Blow....

If the receiver should fail to turn on and you think it is because the power fuse has blown, remove the power cord from its wall outlet, unscrew and take out the fuse holder on the rear panel to see if it has blown. If it has, replace it with a 2A glass-tubed fuse. Using thin wire or a fuse of a different capacity as a stop-gap measure is very dangerous and should be absolutely avoided.

If the fuse has blown because of a trouble in the



receiver, be sure to find and eliminate it first before replacing the fuse. Should the new fuse blow when the POWER switch is pushed, it is very likely that the power amplifier circuit is at fault and it should be replaced or repaired.

Should a Quick-Acting Fuse Blow..

The expensive silicon power transistors in the 300 are safely protected by a pair of quick-acting fuses in the right and left channels. Should the output circuit be short-circuited (e.g., at speaker terminals) for some reason or should an overcurrent from the input circuit flow into the power transistors, one or both of these quick-acting fuses will instantly blow and the sound will be cut off. If this happens, shut off the power supply immediately, discover and eliminate the cause, then replace the blown fuses.

Replacing Quick-Acting Fuses

If one or both quick-acting fuses should blow, replace them with 1.5A quick-acting fuses (supplied). Never use other kinds of fuse, or the silicon power transistors may be damaged in the future. Before replacing be sure to discover and eliminate the cause of the blowout.

Power Handling Capacity of Speakers

Most speaker specifications include a maximum power rating. This rating, in watts, is not to be confused with required amplifier power. It is, rather, the maximum power which may be applied to the speaker for any length of time without actually damaging it. If the speaker with relatively small capacity is connected to the amplifier, it may be damaged at high listening levels.

SPECIFICATIONS

AUDIO SECTION

POWER OUTPUT

MUSIC POWER (IHF): 36W (at 4 ohms load)
32W (at 8 ohms load)

CONTINUOUS POWER (each channel):
16/16W (at 4 ohms load)
14/14W (at 8 ohms load)

TOTAL HARMONIC DISTORTION:

less than 1% at rated output

POWER BANDWIDTH (IHF):

30 to 25,000Hz (at 8 ohms load)

FREQUENCY RESPONSE (at normal listening level):

AUX OVER ALL: 25 to 30,000Hz \pm 2dB

CHANNEL SEPARATION: (at 1,000Hz rated output)

PHONO: better than 40dB

AUX: better than 45dB

HUM AND NOISE (IHF)

PHONO: better than 65dB

AUX: better than 70dB

INPUT SENSITIVITY (at 1,000Hz rated output):

PHONO: 3mV (50k ohms)

AUX: 180mV (100k ohms)

TAPE MON (PIN): 180mV (100k ohms)

TAPE RECORDER (DIN): 180mV (100k ohms)

RECORDING OUTPUT

TAPE REC (PIN): 180mV

TAPE RECORDER (DIN): 30mV

LOAD IMPEDANCE: 4 to 16 ohms

DAMPING FACTOR: 20 at 8 ohms load

EQUALIZER PHONO: RIAA, NF type

tone CONTROLS

BASS: \pm 10dB at 50Hz

TREBLE: \pm 10dB at 10,000Hz

LOUDNESS CONTROL: +11dB at 50Hz, +3dB
10,000Hz (Volume Control at
-30dB)

SWITCHES

SELECTOR: PHONO, FM AUTO, AM, AUX

TAPE MONITOR: OFF, ON

MODE: STEREO, MONO

MPX NOISE CANCELER: OFF, ON

OTHER SPECIAL FEATURES

DIN Connector for Tape Recorder, Direct Tape Monitor
Head Phone jack,

TUNER SECTION

FM

TUNING RANGE: 88 to 108 MHz

SENSITIVITY (20dB quieting): 2.5 μ V
(IHF): 3 μ V

HARMONIC DISTORTION: less than 1%

SIGNAL TO NOISE RATIO: better than 50dB

SELECTIVITY: better than 35dB at 98MHz

CAPTURE RATIO (IHF): 3dB

IMAGE FREQUENCY REJECTION:

better than 45dB at 98MHz

IF REJECTION: better than 60dB at 98MHz

SPURIOUS RESPONSE REJECTION:

better than 60dB at 98MHz

SPURIOUS RADIATION: less than 34dB

ANTENNA INPUT IMPEDANCE:

300 ohms balanced, 75 ohms
unbalanced

FM STEREO SEPARATION:

better than 30dB at 400Hz

AM

TUNING RANGE: 535 to 1605kHz

SENSITIVITY: 51dB/m at 1,000kHz
(bar antenna)

IMAGE FREQUENCY REJECTION:

better than 55dB at 1,000kHz

IF REJECTION: better than 45dB

SELECTIVITY: better than 20dB

OTHER SPECIAL FEATURES:

FM Linear Scale Dial, Signal Strength Meter, Fly-wheel
Tuning, AM Ferrite Bar Antenna, MPX Noise Canceler.

TRANSISTORS AND DIODES

Transistors: 36, FET: 1, Varistors: 2, Thermistor: 1
Diodes: 18, Zener Diode: 1

POWER REQUIREMENTS

POWER VOLTAGE: 100, 110, 117, 127, 220, 230,
240, 250V 50/60Hz

POWER CONSUMPTION: 15VA (Zero Signal),
100VA (Max Signal)

DIMENSIONS

15-7/8"W 4-9/16"H

11-1/16"D

WEIGHT

21 lbs.

* All rights reserve specifications subject to change without notice.

MAINTENANCE

Voltage Adjustment

The Voltage Adjustor on the rear of the chassis enables you to operate the 300 at correct voltage in any areas. The voltage has been pre-adjusted at the factory, but can be easily readjusted as follows:

STEP I Set arrow of main voltage selector plug to required voltage: 100, 110, 117, 127, 220, 230, 240 or 250 volts.

STEP II If numerals of voltage are printed in red, set arrow of adjacent sub V.S. plug to position marked red. If they are printed in white, set arrow to position marked white.

NOTE: The Voltage Adjustor can be used to eliminate the trouble caused by the considerable voltage fluctuation. In this case, it should be set to the peak voltage.

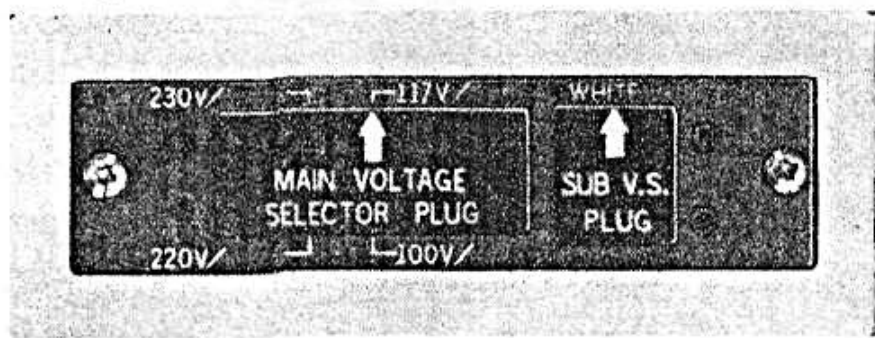

Should the Power Fuse Blow....

If the receiver should fail to turn on and you think it is because the power fuse has blown, remove the power cord from its wall outlet, unscrew and take out the fuse holder on the rear panel to see if it has blown. If it has, replace it with a 2A glass-tubed fuse. Using thin wire or a fuse of a different capacity as a stop-gap measure is very dangerous and should be absolutely avoided.

If the fuse has blown because of a trouble in the



receiver, be sure to find and eliminate it first before replacing the fuse. Should the new fuse blow when the POWER switch is pushed, it is very likely that the power amplifier circuit is at fault and it should be replaced or repaired.

Should a Quick-Acting Fuse Blow..

The expensive silicon power transistors in the 300 are safely protected by a pair of quick-acting fuses in the right and left channels. Should the output circuit be short-circuited (e.g., at speaker terminals) for some reason or should an overcurrent from the input circuit flow into the power transistors, one or both of these quick-acting fuses will instantly blow and the sound will be cut off. If this happens, shut off the power supply immediately, discover and eliminate the cause, then replace the blown fuses.

Replacing Quick-Acting Fuses

If one or both quick-acting fuses should blow, replace them with 1.5A quick-acting fuses (supplied). Never use other kinds of fuse, or the silicon power transistors may be damaged in the future. Before replacing be sure to discover and eliminate the cause of the blowout.

Power Handling Capacity of Speakers

Most speaker specifications include a maximum power rating. This rating, in watts, is not to be confused with required amplifier power. It is, rather, the maximum power which may be applied to the speaker for any length of time without actually damaging it. If the speaker with relatively small capacity is connected to the amplifier, it may be damaged at high listening levels.

SPECIFICATIONS

AUDIO SECTION

POWER OUTPUT

MUSIC POWER (IHF): 36W (at 4 ohms load)
32W (at 8 ohms load)

CONTINUOUS POWER (each channel):
16/16W (at 4 ohms load)
14/14W (at 8 ohms load)

TOTAL HARMONIC DISTORTION:
less than 1% at rated output

POWER BANDWIDTH (IHF):
30 to 25,000Hz (at 8 ohms load)

FREQUENCY RESPONSE (at normal listening level):

AUX OVER ALL: 25 to 30,000Hz \pm 2dB

CHANNEL SEPARATION: (at 1,000Hz rated output)

PHONO: better than 40dB

AUX: better than 45dB

HUM AND NOISE (IHF)

PHONO: better than 65dB

AUX: better than 70dB

INPUT SENSITIVITY (at 1,000Hz rated output):

PHONO: 3mV (50k ohms)

AUX: 180mV (100k ohms)

TAPE MON (PIN): 180mV (100k ohms)

TAPE RECORDER (DIN): 180mV (100k ohms)

RECORDING OUTPUT

TAPE REC (PIN): 180mV

TAPE RECORDER (DIN): 30mV

LOAD IMPEDANCE: 4 to 16 ohms

DAMPING FACTOR: 20 at 8 ohms load

EQUALIZER PHONO: RIAA, NF type

TONE CONTROLS

BASS: \pm 10dB at 50Hz

TREBLE: \pm 10dB at 10,000Hz

LOUDNESS CONTROL: +11dB at 50Hz, +3dB
10,000Hz (Volume Control at
-30dB)

SWITCHES

SELECTOR: PHONO, FM AUTO, AM, AUX

TAPE MONITOR: OFF, ON

MODE: STEREO, MONO

MPX NOISE CANCELER: OFF, ON

OTHER SPECIAL FEATURES

DIN Connector for Tape Recorder, Direct Tape Monitor
Head Phone jack,

TUNER SECTION

FM

TUNING RANGE: 88 to 108 MHz

SENSITIVITY (20dB quieting): 2.5 μ V
(IHF): 3 μ V

HARMONIC DISTORTION: less than 1%

SIGNAL TO NOISE RATIO: better than 50dB

SELECTIVITY: better than 35dB at 98MHz

CAPTURE RATIO (IHF): 3dB

IMAGE FREQUENCY REJECTION:

better than 45dB at 98MHz

IF REJECTION: better than 60dB at 98MHz

SPURIOUS RESPONSE REJECTION:

better than 60dB at 98MHz

SPURIOUS RADIATION: less than 34dB

ANTENNA INPUT IMPEDANCE:

300 ohms balanced, 75 ohms
unbalanced

FM STEREO SEPARATION:

better than 30dB at 400Hz

AM

TUNING RANGE: 535 to 1605kHz

SENSITIVITY: 51dB/m at 1,000kHz
(bar antenna)

IMAGE FREQUENCY REJECTION:

better than 55dB at 1,000kHz

IF REJECTION: better than 45dB

SELECTIVITY: better than 20dB

OTHER SPECIAL FEATURES:

FM Linear Scale Dial, Signal Strength Meter, Fly-wheel
Tuning, AM Ferrite Bar Antenna, MPX Noise Canceler.

TRANSISTORS AND DIODES

Transistors: 36, FET: 1, Varistors: 2, Thermistor: 1
Diodes: 18, Zener Diode: 1

POWER REQUIREMENTS

POWER VOLTAGE: 100, 110, 117, 127, 220, 230,
240, 250V 50/60Hz

POWER CONSUMPTION: 15VA (Zero Signal),
100VA (Max Signal)

DIMENSIONS

15-7/8"W 4-9/16"H

11-1/16"D

WEIGHT

21 lbs.

* All rights reserved specifications subject to change without notice.

TROUBLESHOOTING CHART

If the amplifier is otherwise operating satisfactorily the more common causes of trouble may generally be attributed to the following:

1. Incorrect connections or loose terminal contacts. Check the speakers, record player, tape recorder, antenna and line cord.
2. Improper operation. Before operating any audio component, be sure to read the manufacturer's in-

structions.

3. Improper location of audio components. The proper positioning of components, such as speakers and turntable, is vital to stereo.

4. Defective audio components.

Following are some other common causes of malfunction and what to do about them.

PROGRAM	SYMPTOM	PROBABLE CAUSE	WHAT TO DO
AM, FM or MPX reception	A. Constant or intermittent noise heard at certain times or in a certain area.	<ul style="list-style-type: none"> * Discharge or oscillation caused by electrical appliances, such as fluorescent lamps, TV sets, D.C. motors, rectifier and oscillator * Natural phenomena, such as atmospherics, static, and thunderbolt. * Insufficient antenna input due to reinforced concrete walls or long distance from the station * Wave interference from other electrical appliances 	<ul style="list-style-type: none"> * Attach a noise limiter to the electrical appliance that causes the noise, or attach it to the power source of the amplifier. * Install an outdoor antenna and ground the amplifier to raise the signal-to-noise ratio. * Reverse the power cord plug-receptacle connections. * If the noise occurs at a certain frequency, attach a wave trap to the ANT. input. * Place the set away from other electrical appliances.
	B. Needle of the tuning meter does not move sharply.	<ul style="list-style-type: none"> * Needle movement is not necessarily related to the sensitivity of the amplifier. 	<ul style="list-style-type: none"> * Tune the set for maximum signal strength.
	C. Zero point of the meter moves greatly.	<ul style="list-style-type: none"> * Regional difference in field intensity. 	<ul style="list-style-type: none"> * The unit is not at fault.
AM reception	A. Noise heard at a particular time of day, in a certain area or over part of the dial.	<ul style="list-style-type: none"> * Natural phenomenon. 	<ul style="list-style-type: none"> * Install an antenna for maximum antenna efficiency. See "ANTENNA" in the Operating Instructions. * In some cases, the noise can be eliminated by grounding the amplifier or reversing the power cord plug-receptacle connections.
	B. High-frequency noise	<ul style="list-style-type: none"> * Adjacent-channel interference or beat interference * TV set is too close to the audio system 	<ul style="list-style-type: none"> * Although such noise cannot be eliminated by the amplifier, it is advisable to turn the TREBLE control from midpoint to left. * Place the TV set away from the audio system.
FM reception	A. Noisy	<ul style="list-style-type: none"> * Poor noise limiter effect or too low S/N ratio due to insufficient antenna input. 	<ul style="list-style-type: none"> * Adjust the antenna (supplied) for maximum signal strength. * If this is not effective, use an outdoor antenna designed exclusively for FM. When you use a TV antenna for both TV and FM with a divider, make sure TV reception is not affected. * An excessively long antenna may cause noise.

NOTE: FM reception is affected considerably by the conditions of the transmitting stations: power and antenna efficiency. As a result, you may receive one station quite well while having difficulty receiving another station.

PROGRAM	SYMPTOM	PROBABLE CAUSE	WHAT TO DO
FM reception (Cont'd)	B. A series of pops is heard	* Ignition noise caused by an automobile engine.	* Increase the height of antenna or raise the antenna input as previously described.
	C. Distortion or no sound	* Out of tune due to frequency swing	* Retune the signal.
	D. Tuning noise between stations	* This noise results from the nature of FM reception. As the station signal becomes weak, the noise limiter effect is decreased. The amplification of the limiter, in turn, is enlarged and a noise is generated.	* Tune the signal at reduced volume.
FM-MPX reception	A. Noise heard during FM-MPX reception while not heard during FM mono reception	* The service area of the FM-MPX broadcast is only half that of the FM mono broadcast.	* Install the antenna for maximum antenna input. * Switch on the MPX NOISE CANCELER and/or turn the TREBLE control from midpoint to left.
	B. Channel separation becomes worse during reception.	* Excess heat	* Make sure that air can flow underneath the amplifier.
	C. The stereo indicator comes on and off.	* Interference * Station signal is weak	* The indicator is not at fault. * Adjust VR ₄₀₁
	D. The stereo indicator comes on and off even though a stereo station is not received.	* Interference	* The indicator is not at fault. * Adjust VR ₄₀₁
Record playing or tape playback	A. Hum or howling	* Record player placed directly on the speaker box. * Use of unshielded wire. * Loose terminal contact. * Shielded wire too close to line cord fluorescent lamp or other electrical appliances. * Nearby amateur radio station or TV transmission antenna.	* Put a cushion between the player and the speaker box or separate them. * The connecting shield wire should be as short as possible. * Turn the BASS control from midpoint to left. * Consult the nearest Radio Regulatory Bureau.
	B. Surface noise	* Worn or old record * Dusty record * Worn pick-up needle * Dusty needle * Improper needle pressure	* Remove dust from record and/or needle. * Replace needle. * Correct needle pressure. * Turn the TREBLE control properly from midpoint to left.
Overall stereo program	The BALANCE control is not at midpoint when equal sound comes from left and right channels	* It is important to adjust the control for equal sound from both channels. It should not always be set to midpoint.	* Set the MODE switch to the MONO position and then set the BALANCE control to the position where equal sound comes from both channels.

DISASSEMBLY PROCEDURE / DIAL MECHANISM

REMOVING THE FRONT PANEL, BONNET AND BOTTOM PLATE

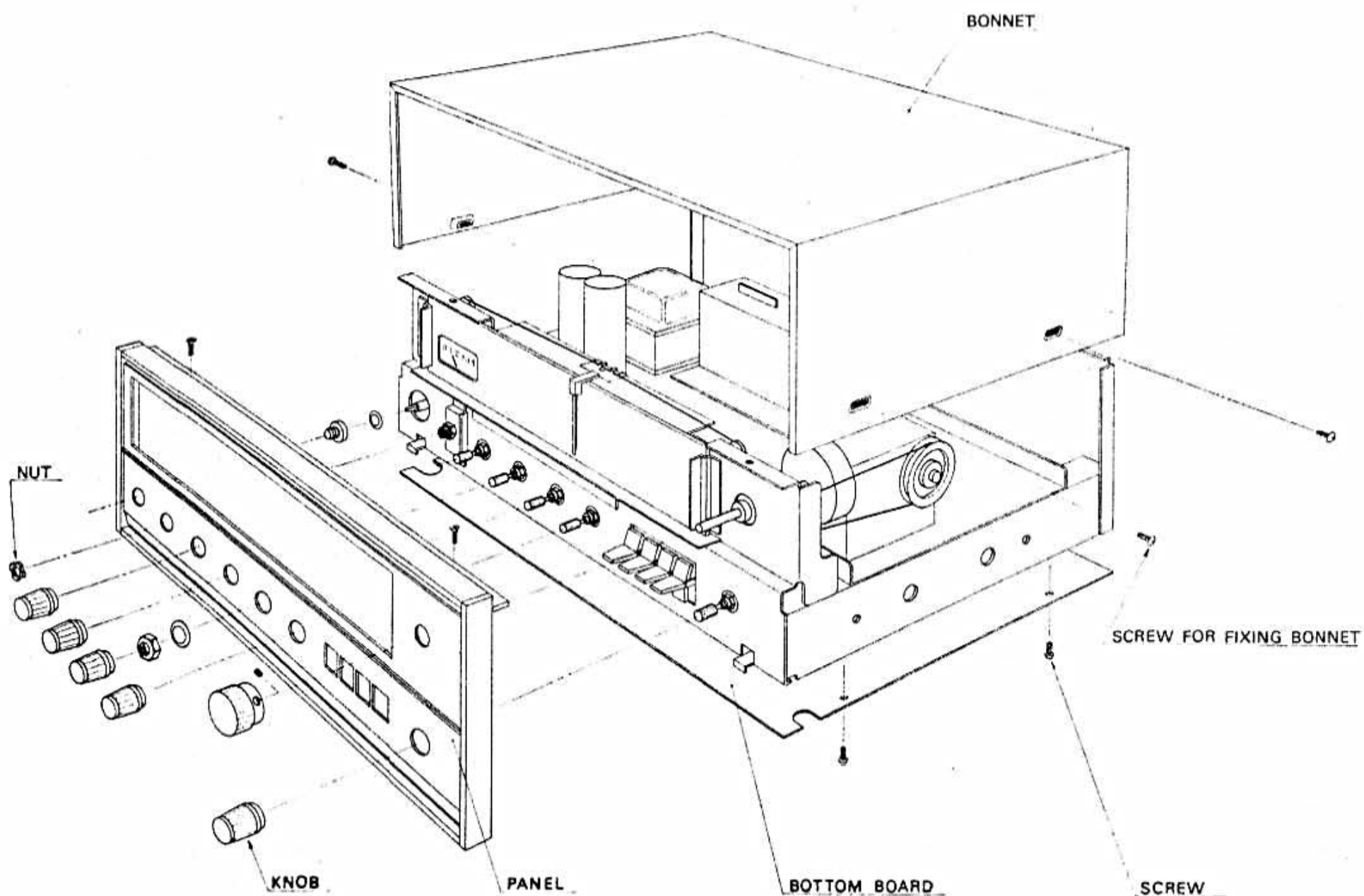

DIAL MECHANISM

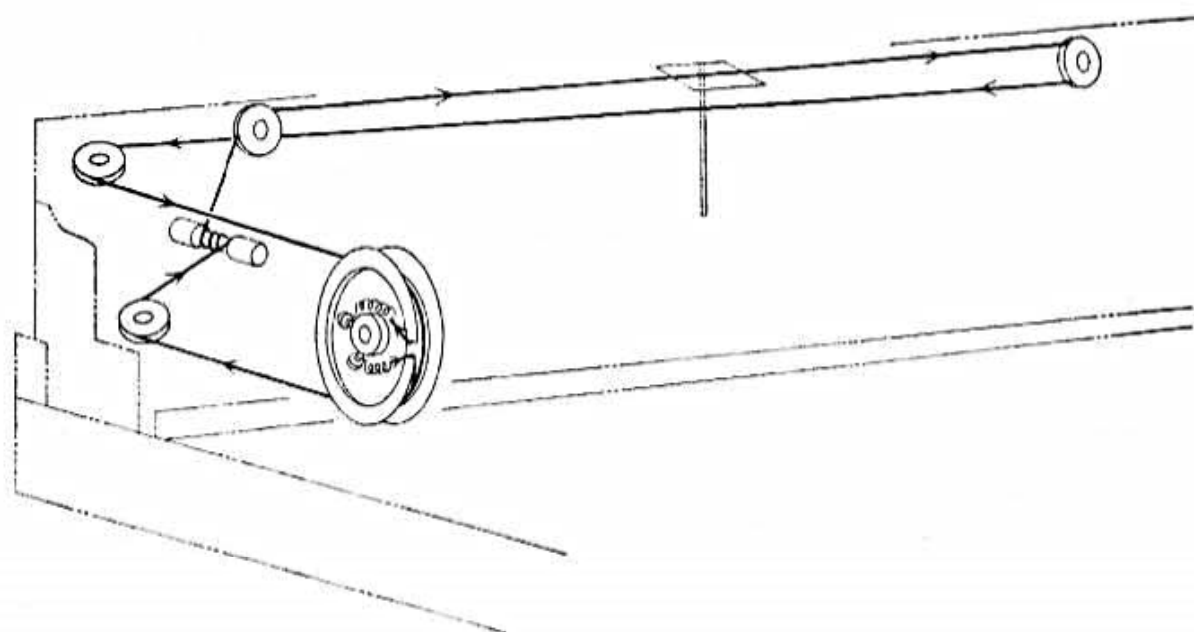

BLOCK DIAGRAM

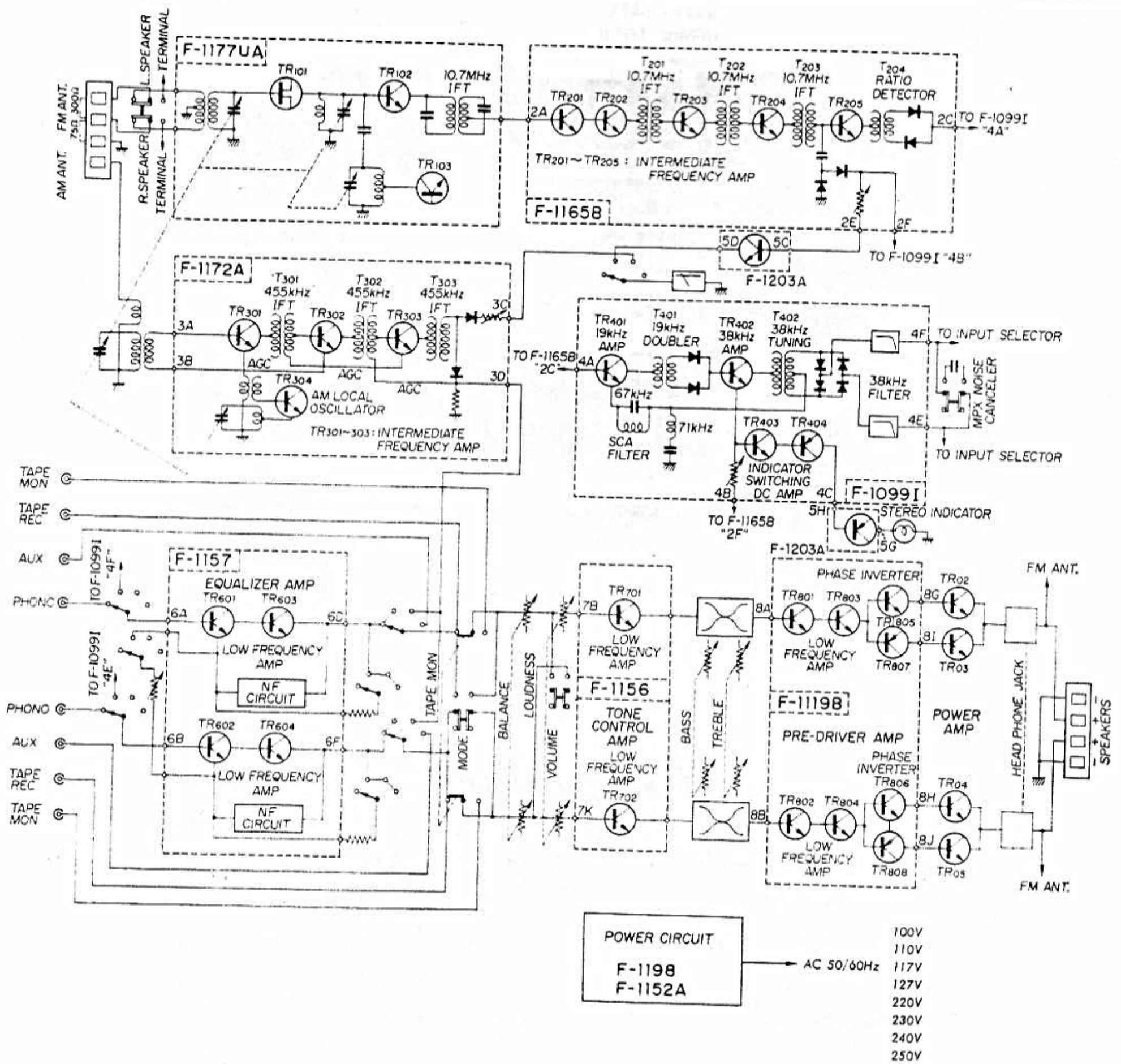

ALIGNMENT

TEST POINTS

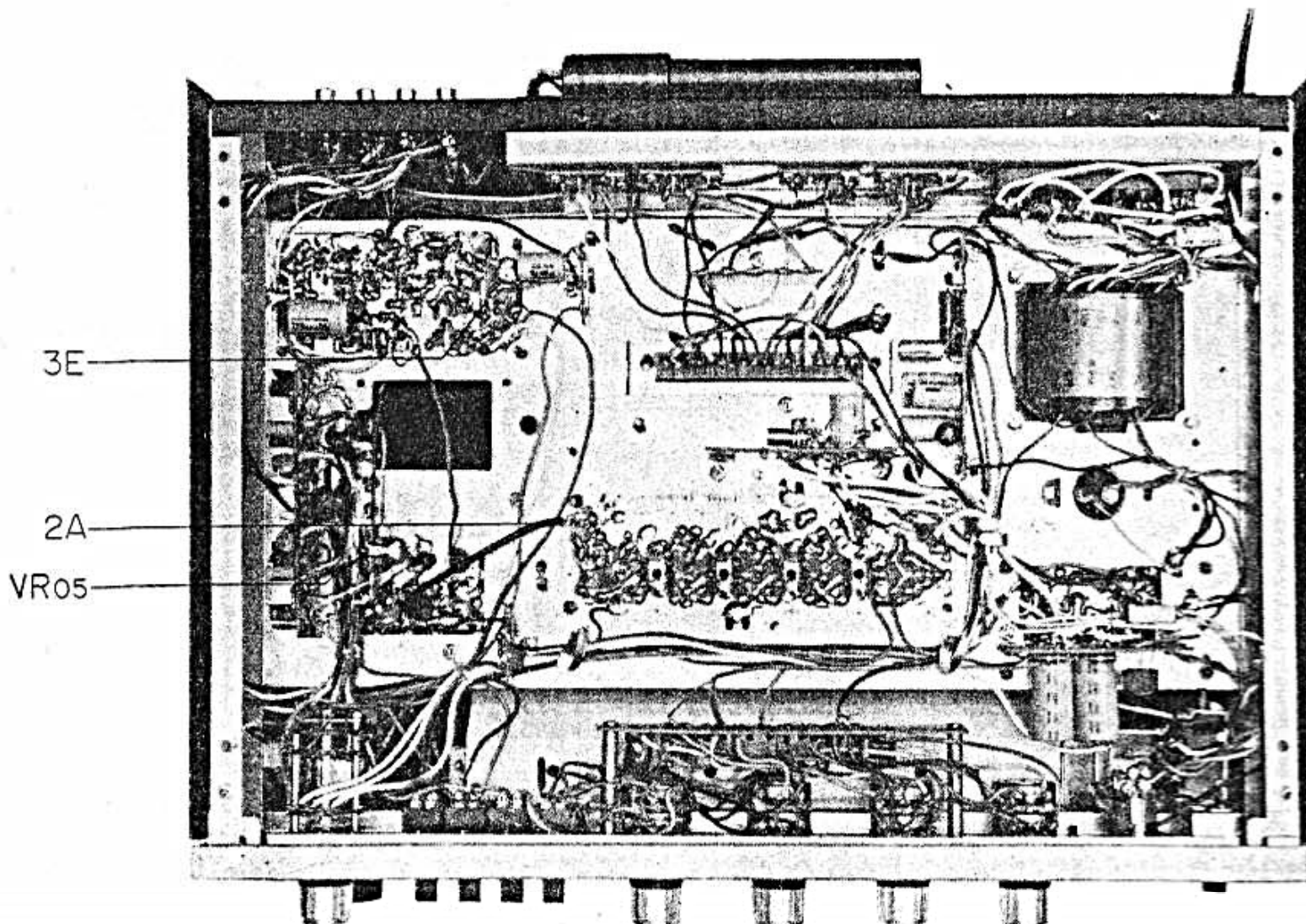
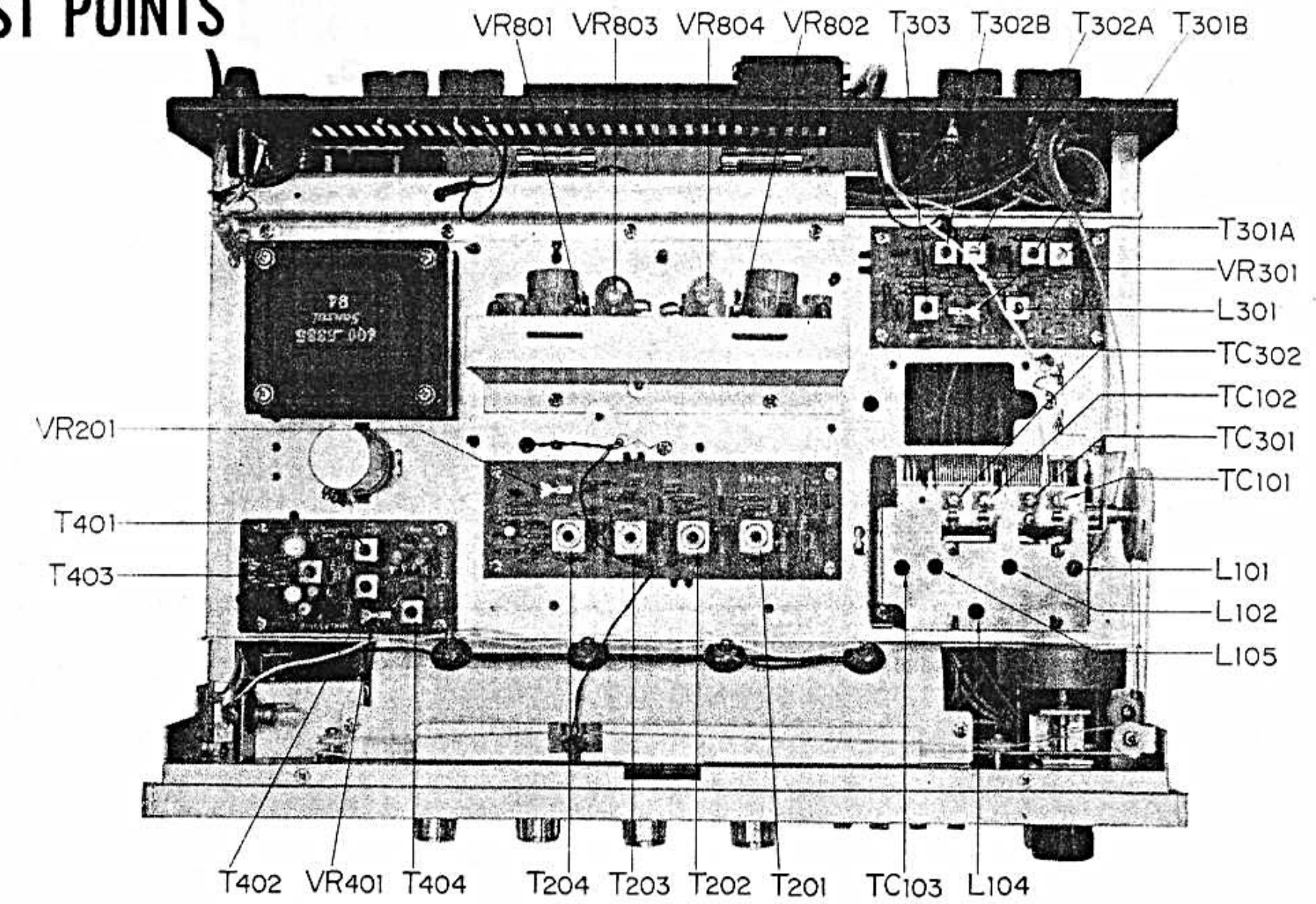

FM ALIGNMENT PROCEDURE

NOTE: To align, set the FM signal generator level to minimum, turn tuning gang fully, center carrier wave, and set pointer to reference mark.

STEP	ALIGN	GENERATOR	FEED SIGNAL TO	TEST EQUIPMENT	SET DIAL TO	ADJUST	ADJUST FOR
1.	IF transformer	10.7MHz Sweep generator	2A via 0.02 μ F ceramic capacitor	Connect oscilloscope to TR ₂₀₅ emitter. Ground TR ₂₀₅ collector via 0.02 μ F ceramic capacitor. at the same time.		Primary and secondary of T ₂₀₁ , T ₂₀₂ , and T ₂₀₃	Best wave form
2.	Discriminator	10.7MHz Sweep generator	2A via 0.02 μ F ceramic capacitor	Connect oscilloscope to TAPE REC.		Primary and secondary of FM Discriminator T ₂₀₄	S curve
3.	Local oscillator	FM signal generator 88MHz/400Hz modulation	Antenna terminals	Oscilloscope and V.T.V.M. at output load	88MHz	Local oscillator coil	Maximum
4.	Local oscillator	FM signal generator 108MHz/400Hz modulation	Antenna terminals	Oscilloscope and V.T.V.M. at output load	108MHz	Local oscillator trimmer TC ₁₀₃	Maximum
5.	Repeat3&4						
6.	HF amp. circuit	FM signal generator 90MHz/400Hz modulation	Antenna terminals	Oscilloscope and V.T.V.M. at output load	90MHz	Antenna coil L ₁₀₁ and L ₁₀₂	Maximum
7.	HF amp. circuit	FM signal generator 106MHz/400Hz modulation	Antenna terminals	Oscilloscope and V.T.V.M. at output load	106MHz	Antenna trimmer TC ₁₀₁ and TC ₁₀₂	Maximum
8.	Repeat6&7						

FM DISCRIMINATOR CHARACTERISTIC

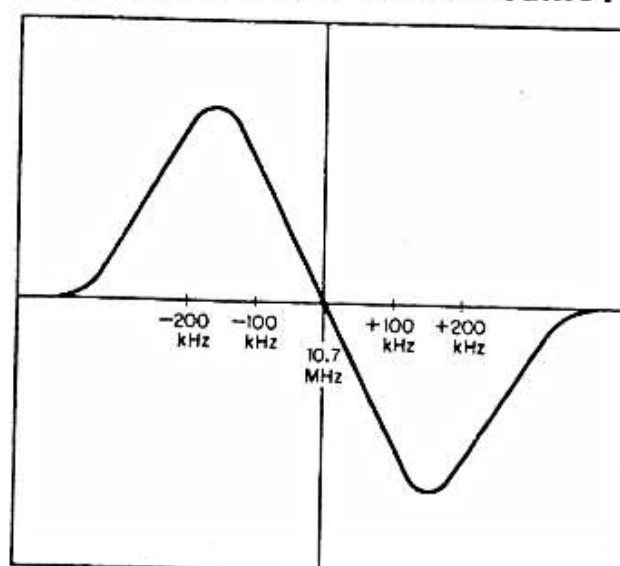

FM IF CHARACTERISTIC

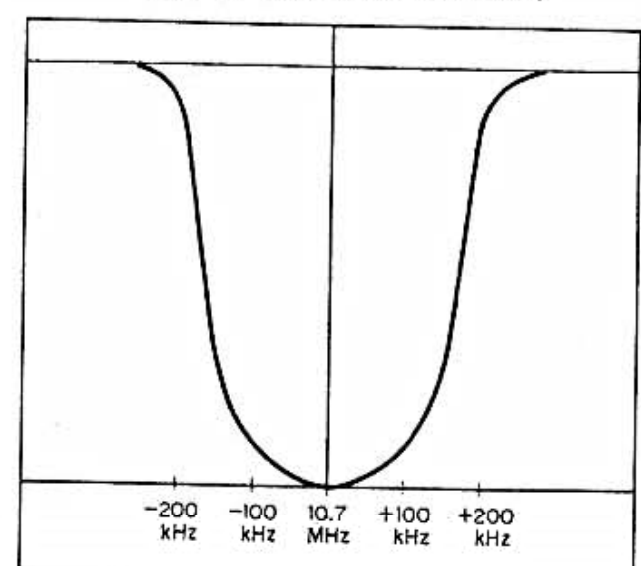

ALIGNMENT

FM MULTIPLEX ALIGNMENT PROCEDURE

1. Do not attempt to align the Multiplex Circuit unless the following equipment is available:

a. Stereo Signal Generator b. Oscilloscope c. AC. V.T.V.M. d. Audio Signal Generator

STEP	ALIGN	GENERATOR	FEED SIGNAL TO	TEST EQUIPMENT	ADJUST	ADJUST FOR
1.	67kHz trap	67kHz audio signal	4A	V.T.V.M. at 4F (4E)	T ₄₀₄	Minimum
2.	19kHz tuning coil	Stereo signal generator, 83 MHz 30% modulation L (or R) channel	Antenna terminals Tune to signal	V.T.V.M. and Oscilloscope at TP. 4I	T ₄₀₁ , T ₄₀₂	Maximum
3.	38kHz tuning coil	Stereo signal generator, 83 MHz 30% modulation L (or R) channel	Antenna terminals Tune to signal	V.T.V.M. and Oscilloscope at TP. 4G	T ₄₀₃	Maximum
4.	Separation VR	Stereo signal generator, 83 MHz 30% modulation L (or R) channel	Antenna terminals Tune to signal	V.T.V.M. and Oscilloscope at output load	T ₄₀₃ VR ₀₅	1) Minimum by turning T ₄₀₃ about 1/4 while watching R- (or L-) channel output 2) Best separation by turning VR ₀₅

AM ALIGNMENT PROCEDURE

NOTE: To align, set the AM Signal Generator level to minimum.

STEP	ALIGN	GENERATOR	FEED SIGNAL TO	OUTPUT INDICATOR	SET DIAL TO	ADJUST	ADJUST FOR
1.	I.F. transformer	455 kHz sweep generator	Antenna terminals	Oscilloscope at 3E		Primary and secondary of I.F.T. $T_{301} \sim T_{303}$	Best wave form
2.	Local oscillator	AM signal generator, 535 kHz/400Hz 30% modulation	Antenna terminals	Oscilloscope and V.T.V.M. at output load	535 kHz	Local oscillator coil L_{301}	Maximum
3.	Local oscillator	AM signal generator, 1600 kHz/400Hz 30% modulation	Antenna terminals	Oscilloscope and V.T.V.M. at output load	1600 kHz	Local oscillator trimmer TC_{302}	Maximum
4.	Repeat 2 and 3						
5.	HF amp circuit	AM signal generator, 600 kHz/400Hz 30% modulation	Antenna terminals	Oscilloscope and V.T.V.M. at output load	600 kHz	Ferrite antenna	Maximum
6.	HF amp circuit	AM signal generator, 1400 kHz/400Hz 30% Modulation	Antenna terminals	Oscilloscope and V.T.V.M. at output load	1400 kHz	Antenna trimmer TC_{301}	Maximum
7.	Repeat 5 and 6						

AM IF CHARACTERISTIC

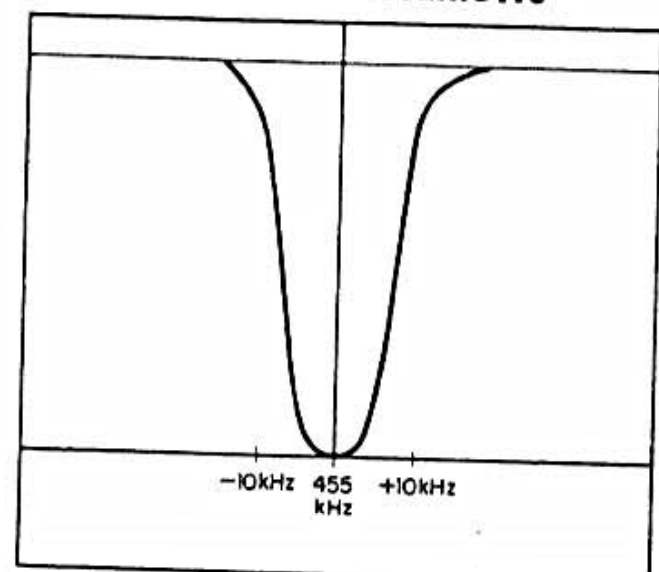

PRINTED CIRCUIT BOARDS AND PARTS LIST

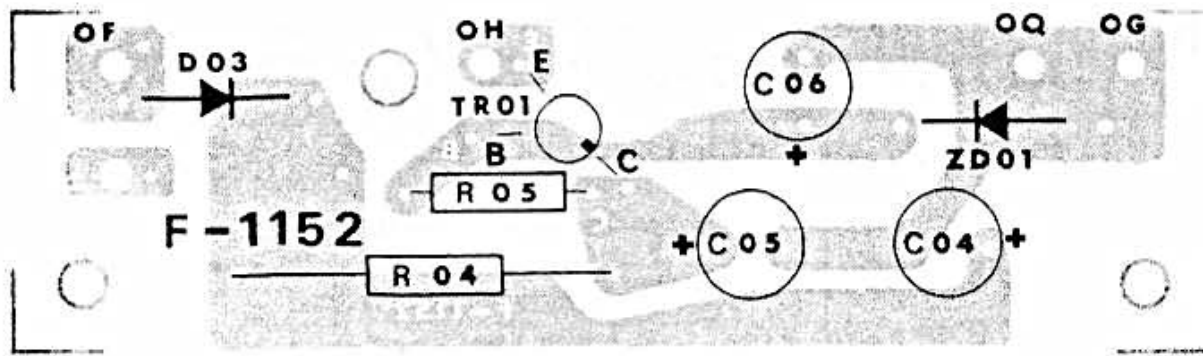

POWER BLOCK <F-1152A>

X	Y	Z
R004	560Ω ±10% 1 W Carbon Resistor	
R005	560Ω ±10% ½ W Solid Resistor	
C004	100μF $\frac{+100\%}{-0\%}$ 50 WV Electrolytic Capacitor	
C005	100μF $\frac{+100\%}{-0\%}$ 25 WV Electrolytic Capacitor	
C006	100μF $\frac{+100\%}{-0\%}$ 16 WV Electrolytic Capacitor	
TR001	2SC971(3) (030553-1)	
D003	10D1 Diode (031034)	
ZD001	ZBI-12 Zener Diode (031064-1)	

POWER BLOCK <F-1198>

X	Y	Z
R001	2.2kΩ ±10% ½ W Solid Resistor	
R002	390Ω ±10% ½ W Solid Resistor	
C001	330μF $\frac{+100\%}{-0\%}$ 50 WV Electrolytic Capacitor	
C002	330μF $\frac{+100\%}{-0\%}$ 50 WV Electrolytic Capacitor	
D001	IODC(N) (031068)	
D002	IODC(R) (031067)	

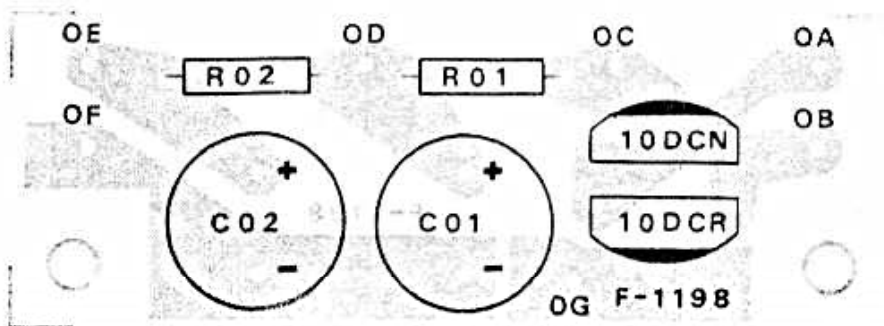

TONE CONTROL BLOCK <F-1156>

X	Y	Z
R701	1kΩ ±10% ¼ W Carbon Resistor	1 B
R702	1kΩ ±10% ¼ W Carbon Resistor	1 C
R703	1MΩ ±10% ¼ W Carbon Resistor	1 B
R704	1MΩ ±10% ¼ W Carbon Resistor	1 C
R705	4.7kΩ ±10% ¼ W Carbon Resistor	1 B
R706	4.7kΩ ±10% ¼ W Carbon Resistor	1 C
R707	560Ω ±10% ¼ W Carbon Resistor	1 B
R708	560Ω ±10% ¼ W Carbon Resistor	1 C, D
R709	33kΩ ±10% ¼ W Carbon Resistor	1 A
R710	33kΩ ±10% ¼ W Carbon Resistor	1 D
R711	1kΩ ±10% ¼ W Carbon Resistor	1 A
R712	1kΩ ±10% ¼ W Carbon Resistor	1 D
R713	3.3kΩ ±10% ¼ W Carbon Resistor	1 B
R714	3.3kΩ ±10% ¼ W Carbon Resistor	1 C
R715	27kΩ ±10% ¼ W Carbon Resistor	1 A
R716	27kΩ ±10% ¼ W Carbon Resistor	1 D
C701	1μF $\frac{+100\%}{-0\%}$ 50 WV Electrolytic Capacitor	1 B
C702	1μF $\frac{+100\%}{-0\%}$ 50 WV Electrolytic Capacitor	1 C
C703	3.3μF $\frac{+100\%}{-0\%}$ 25 WV Electrolytic Capacitor	1 A, B
C704	3.3μF $\frac{+100\%}{-0\%}$ 25 WV Electrolytic Capacitor	1 C
C705	0.002μF ±10% 50 WV Mylar Capacitor	1 A
C706	0.002μF ±10% 50 WV Mylar Capacitor	1 C
C707	0.012μF ±10% 50 WV Mylar Capacitor	1 A
C708	0.012μF ±10% 50 WV Mylar Capacitor	1 D
C709	0.1μF ±10% 50 WV Mylar Capacitor	1 A
C710	0.1μF ±10% 50 WV Mylar Capacitor	1 D
C711	0.02μF ±10% 50 WV Mylar Capacitor	1 B
C712	0.02μF ±10% 50 WV Mylar Capacitor	1 C
TR701	2SC870(E) (030551-0)	1 B
TR702	2SC870(E) (030551-0)	1 C

X: Parts No Y: Parts Name Z: Position of Part

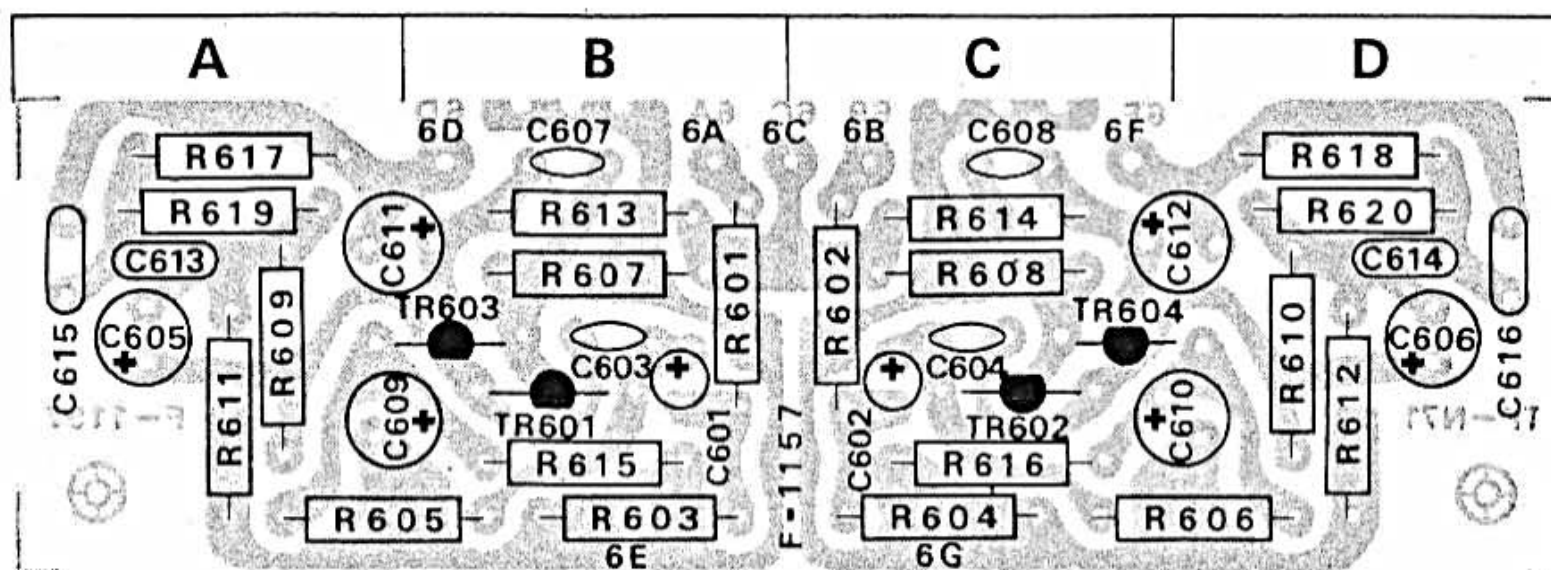

EQUALIZER AMP. BLOCK (F-1157)

X	Y	Z
R601	1kΩ ±10% ¼W Carbon Resistor	1 B
R602	1kΩ ±10% ¼W Carbon Resistor	1 C
R603	68kΩ ±10% ¼W Carbon Resistor	1 B
R604	68kΩ ±10% ¼W Carbon Resistor	1 C
R605	270kΩ ±10% ¼W Carbon Resistor	1 A
R606	270kΩ ±10% ¼W Carbon Resistor	1 D
R607	220kΩ ±10% ¼W Carbon Resistor	1 B
R608	220kΩ ±10% ¼W Carbon Resistor	1 C
R609	1.8kΩ ±10% ¼W Carbon Resistor	1 A
R610	1.8kΩ ±10% ¼W Carbon Resistor	1 D
R611	390Ω ±10% ¼W Carbon Resistor	1 A
R612	390Ω ±10% ¼W Carbon Resistor	1 D
R613	6.8kΩ ±10% ¼W Carbon Resistor	1 B
R614	6.8kΩ ±10% ¼W Carbon Resistor	1 C
R615	680Ω ±10% ¼W Carbon Resistor	1 B
R616	680Ω ±10% ¼W Carbon Resistor	1 C
R617	25kΩ ±10% ¼W Carbon Resistor	1 A
R618	25kΩ ±10% ¼W Carbon Resistor	1 D
R619	330kΩ ±10% ¼W Carbon Resistor	1 A
R620	330kΩ ±10% ¼W Carbon Resistor	1 D
R621	82kΩ ±10% ¼W Carbon Resistor	1
R622	82kΩ ±10% ¼W Carbon Resistor	1

X	Y	Z
C601	1μF 25 WV Tantalum Capacitor	1 B
C602	1μF 25 WV Tantalum Capacitor	1 C
C603	150 pF ±10% 50 WV Ceramic Capacitor	1 B
C604	150 pF ±10% 50 WV Ceramic Capacitor	1 C
C605	33μF +100% -0% 6.3 WV Electrolytic Capacitor	1 A
C606	33μF +100% -0% 6.3 WV Electrolytic Capacitor	1 D
C607	150 pF ±10% 50 WV Ceramic Capacitor	1 B
C608	150 pF ±10% 50 WV Ceramic Capacitor	1 C
C609	33μF +100% -0% 6.3 WV Electrolytic Capacitor	1 A
C610	33μF +100% -0% 6.3 WV Electrolytic Capacitor	1 C
C611	10μF +100% -0% 25 WV Electrolytic Capacitor	1 A
C612	10μF +100% -0% 25 WV Electrolytic Capacitor	1 C
C613	0.01μF ±10% 50 WV Mylar Capacitor	1 A
C614	0.01μF ±10% 50 WV Mylar Capacitor	1 D
C615	0.003μF ±10% 50 WV Mylar Capacitor	1 A
C616	0.003μF ±10% 50 WV Mylar Capacitor	1 D
TR601	25C871(E) (030547-1)	1 B
TR602	25C871(E) (030547-1)	1 C
TR603	25C870(E) (030551-0)	1 B
TR604	25C870(E) (030551-0)	1 C

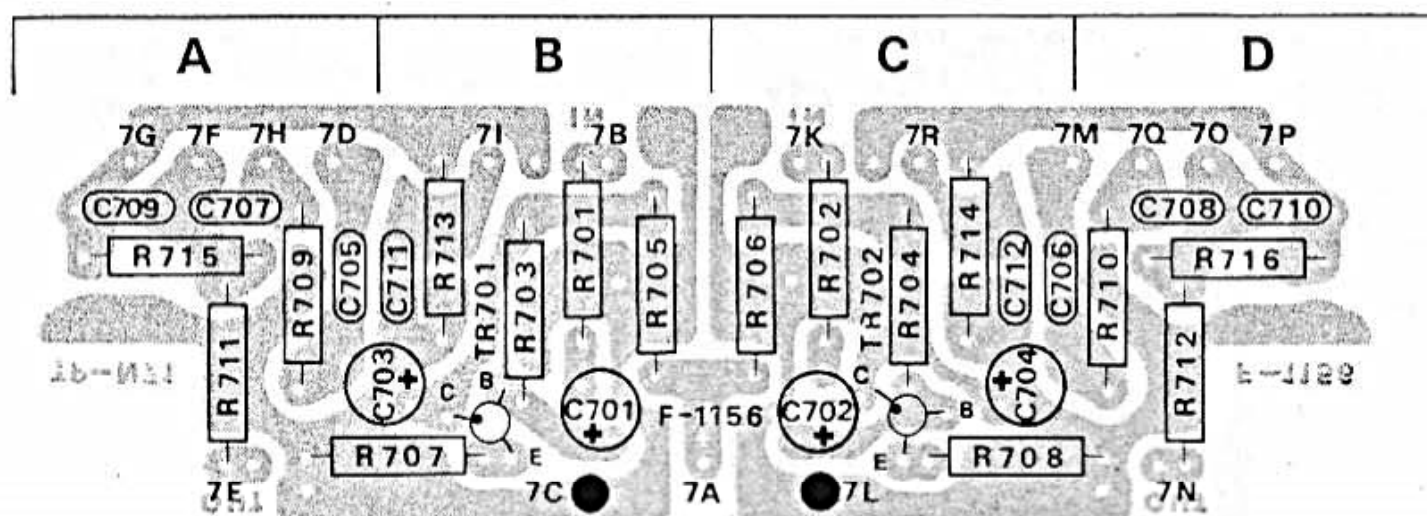

PRINTED CIRCUIT BOARDS AND PARTS LIST

FM IF BLOCK (F-1165B)

X	Y	Z
R201	4.7kΩ ±10% ¼W Carbon Resistor	2A
R202	18kΩ ±10% ¼W Carbon Resistor	1A
R203	1kΩ ±10% ¼W Carbon Resistor	2A
R204	1kΩ ±10% ¼W Carbon Resistor	1A
R205	5.6kΩ ±10% ¼W Carbon Resistor	2A
R206	12kΩ ±10% ¼W Carbon Resistor	1A
R207	1kΩ ±10% ¼W Carbon Resistor	2A
R208	1kΩ ±10% ¼W Carbon Resistor	1B
R209	5.6kΩ ±10% ¼W Carbon Resistor	2B
R210	15kΩ ±10% ¼W Carbon Resistor	1B
R211	1kΩ ±10% ¼W Carbon Resistor	2B
R212	1kΩ ±10% ¼W Carbon Resistor	1C
R213	22Ω ±10% ¼W Carbon Resistor	1C
R214	5.6kΩ ±10% ¼W Carbon Resistor	2C
R215	12kΩ ±10% ¼W Carbon Resistor	1C
R216	1kΩ ±10% ¼W Carbon Resistor	2C
R217	680Ω ±10% ¼W Carbon Resistor	1D
R218	22Ω ±10% ¼W Carbon Resistor	1D
R219	6.8kΩ ±10% ¼W Carbon Resistor	2D
R220	10kΩ ±10% ¼W Carbon Resistor	1D
R221	1kΩ ±10% ¼W Carbon Resistor	2E
R222	1kΩ ±10% ¼W Carbon Resistor	1E
R223	1kΩ ±10% ¼W Carbon Resistor	2E
R224	22Ω ±10% ¼W Carbon Resistor	1E
R225	1kΩ ±10% ¼W Carbon Resistor	1F
R226	1kΩ ±10% ¼W Carbon Resistor	1F
R227	10kΩ ±10% ¼W Carbon Resistor	1F
R228	10kΩ ±10% ¼W Carbon Resistor	1F
R229	68Ω ±10% ¼W Carbon Resistor	1F
R230	56Ω ±10% ¼W Carbon Resistor	2F
R232	22Ω ±10% ¼W Carbon Resistor	1B
C202	0.001μF +100% -0% 25 WV Ceramic Capacitor	2A
C203	0.02μF +100% -0% 25 WV Ceramic Capacitor	2A
C204	100 pF +100% -0% 50 WV Ceramic Capacitor	2A
C205	0.02μF +100% -0% 25 WV Ceramic Capacitor	2B

X	Y	Z
C206	0.02μF +100% -0% 25 WV Ceramic Capacitor	1A
C207	0.02μF +100% -0% 25 WV Ceramic Capacitor	2B
C208	0.02μF +100% -0% 25 WV Ceramic Capacitor	2C
C209	0.02μF +100% -0% 25 WV Ceramic Capacitor	1B
C210	0.02μF +100% -0% 25 WV Ceramic Capacitor	2C
C211	0.02μF +100% -0% 25 WV Ceramic Capacitor	2D
C212	0.02μF +100% -0% 25 WV Ceramic Capacitor	1C
C213	0.02μF +100% -0% 25 WV Ceramic Capacitor	2D
C214	3.3 pF +100% -0% 50 WV Ceramic Capacitor	2D
C215	0.02μF +100% -0% 25 WV Ceramic Capacitor	2E
C216	0.02μF +100% -0% 25 WV Ceramic Capacitor	1D
C217	0.02μF +100% -0% 25 WV Ceramic Capacitor	1F
C218	0.02μF +100% -0% 25 WV Ceramic Capacitor	2D
C219	0.02μF +100% -0% 25 WV Ceramic Capacitor	2E
C220	150 pF ±10% 50 WV Ceramic Capacitor	1F
C221	220 pF ±10% 50 WV Ceramic Capacitor	1F
C222	220 pF ±10% 50 WV Ceramic Capacitor	2F
C223	10μF +100% -0% 10 WV Electrolytic Capacitor	1F
TR201	2SC829(C) (030546-1)	1A
TR202	2SC829(C) (030546-1)	1A
TR203	2SC829(B) (030546)	1B
TR204	2SC829(B) (030546)	1C
TR205	2SC829(B) (030546)	1C, D
D201	IN60 Diode (031033)	2C
D202	IN60 Diode (031033)	2D
VR201	50kΩB Meter Adjustment (103020)	
T201	FM 10.7MHz IFT (423543)	1B
T202	FM 10.7MHz IFT (423544)	1C
T203	FM 10.7MHz IFT (423542)	1D
T204	FM 10.7MHz IFT (423518)	1E

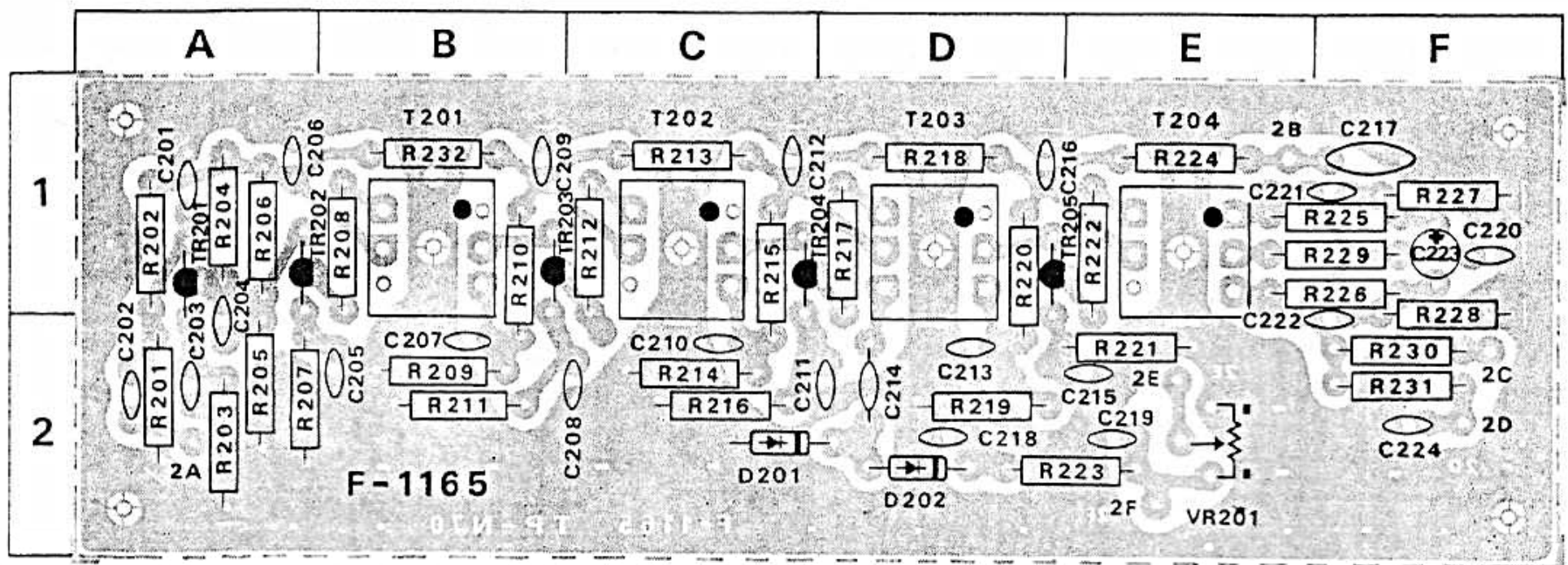

AM TUNER BLOCK <F-1172A>

X	Y	Z
R301	1kΩ ±10% ¼W Carbon Resistor	1D
R302	15kΩ ±10% ¼W Carbon Resistor	1B
R303	560Ω ±10% ¼W Carbon Resistor	1D
R304	120kΩ ±10% ¼W Carbon Resistor	1C
R305	1kΩ ±10% ¼W Carbon Resistor	1C
R306	10kΩ ±10% ¼W Carbon Resistor	1B
R307	47kΩ ±10% ¼W Carbon Resistor	1A
R308	1kΩ ±10% ¼W Carbon Resistor	1A
R309	1kΩ ±10% ¼W Carbon Resistor	2A
R310	1kΩ ±10% ¼W Carbon Resistor	2A
R311	27kΩ ±10% ¼W Carbon Resistor	2A
R312	5.6kΩ ±10% ¼W Carbon Resistor	2D
R313	27kΩ ±10% ¼W Carbon Resistor	1D
R314	1kΩ ±10% ¼W Carbon Resistor	2D
R315	4.7kΩ ±10% ¼W Carbon Resistor	1C
R316	6.8kΩ ±10% ¼W Carbon Resistor	1B
R317	120Ω ±10% ¼W Carbon Resistor	2C
R318	56Ω ±10% ¼W Carbon Resistor	2B
R319	56Ω ±10% ¼W Carbon Resistor	1A
C301	3.3μF +100% -0% 25 WV Electrolytic Capacitor	1B
C302	0.02μF +100% -0% 25 WV Ceramic Capacitor	1D
C303	0.02μF +100% -0% 25 WV Ceramic Capacitor	1D
C304	0.05μF +100% -0% 25 WV Ceramic Capacitor	1D
C305	0.05μF +100% -0% 25 WV Ceramic Capacitor	1C
C306	0.05μF +100% -0% 25 WV Ceramic Capacitor	1C
C307	0.05μF +100% -0% 25 WV Ceramic Capacitor	1C
C308	0.05μF +100% -0% 25 WV Ceramic Capacitor	1B
C309	0.05μF +100% -0% 25 WV Ceramic Capacitor	1A

X	Y	Z
C310	3.3μF +100% -0% 25 WV Electrolytic Capacitor	1B
C311	0.05μF +100% -0% 25 WV Ceramic Capacitor	2A
C312	0.01μF +100% -0% 25 WV Ceramic Capacitor	2B
C313	0.02μF +100% -0% 25 WV Ceramic Capacitor	2A
C314	0.08μF ±10% 50 WV Mylar Capacitor	2A
C315	0.05μF +100% -0% 25 WV Ceramic Capacitor	2A
C319	22pF ±10% 50 WV Ceramic Capacitor	2B
C320	470pF ±5% 50 WV Styrol Capacitor	2C
C321	0.01μF +100% -0% 25 WV Ceramic Capacitor	2C
C322	0.05μF +100% -0% 25 WV Ceramic Capacitor	1A
C323	220μF +100% -0% 16 WV Electrolytic Capacitor	
TR301	2SC454(B) (030542-1)	1D
TR302	2SC454(B) (030542-1)	1C
TR303	2SC454(B) (030542-1)	1A
TR304	2SC454(B) (030542-1)	2D
D301	IN34A Diode (031040-1)	2B
D302	IN34A Diode (031040-1)	2B
VR301	10kΩ B Level Adjustment (103019)	2B
L302	AM OSC Coil (422011)	2C
T301A	AM 455kHz IFT (423030)	1D
T301B	AM 455kHz IFT (423031)	1C
T302A	AM 455kHz IFT (423030)	1B
T302B	AM 455kHz IFT (423031)	1B
T303	AM 455kHz IFT (423032)	2A

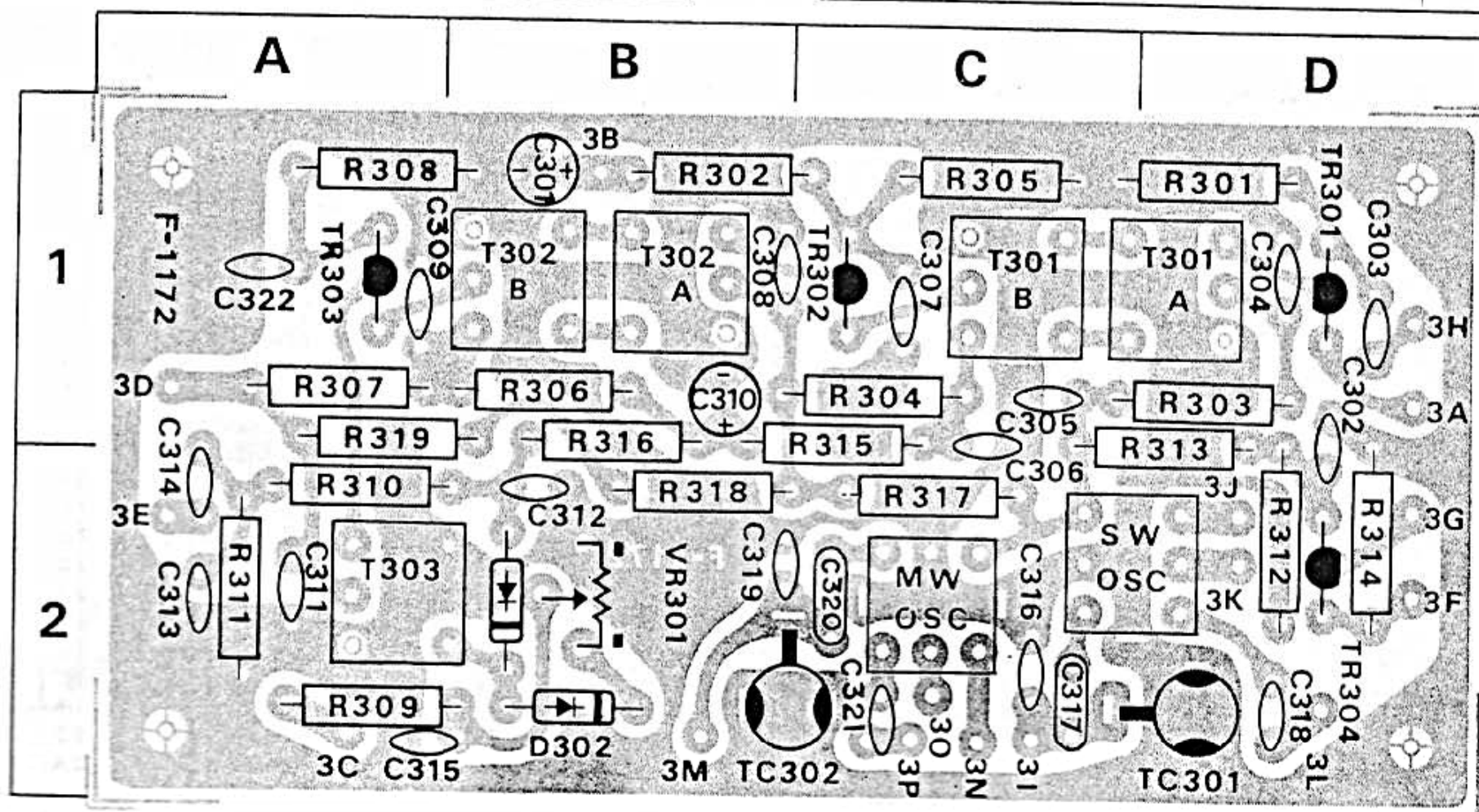

PRINTED CIRCUIT BOARDS AND PARTS LIST

MULTIPLEX BLOCK <F-1099 I>

X	Y	Z
R401	1kΩ ±10% ¼W Carbon Resistor	1C
R402	22kΩ ±10% ¼W Carbon Resistor	1C
R403	22kΩ ±10% ¼W Carbon Resistor	1C
R404	8.2kΩ ±10% ¼W Carbon Resistor	1C
R405	270Ω ±10% ¼W Carbon Resistor	1C
R406	3.3kΩ ±10% ¼W Carbon Resistor	2A
R407	18kΩ ±10% ¼W Carbon Resistor	1B
R408	1.2kΩ ±10% ¼W Carbon Resistor	2B
R409	47Ω ±10% ¼W Carbon Resistor	1B
R410	22kΩ ±10% ¼W Carbon Resistor	1A
R411	22kΩ ±10% ¼W Carbon Resistor	2A
R412	22kΩ ±10% ¼W Carbon Resistor	2A
R413	22kΩ ±10% ¼W Carbon Resistor	2A
C401	100 pF ±10% 25 WV Ceramic Capacitor	1C
C402	10 μF +100% -0% 10 WV Electrolytic Capacitor	1C
C403	33 μF +100% -0% 6.3 WV Electrolytic Capacitor	1C
C404	1000 pF ±5% 50 WV Styrol Capacitor	2C
C405	270 pF ±5% 50 WV Styrol Capacitor	2C
C406	47 μF +100% -0% 6.3 WV Electrolytic Capacitor	2A
C407	3300 pF ±10% 50 WV Styrol Capacitor	1C
C408	330 pF ±10% 50 WV Mica Capacitor	1B
C409	3300 pF ±5% 50 WV Styrol Capacitor	2B
C410	0.04 μF ±10% 50 WV Mylar Capacitor	2B
C411	1500 pF ±5% 50 WV Styrol Capacitor	1B
C412	100 μF +100% -0% 16 WV Electrolytic Capacitor	1A
C413	680 pF ±5% 50 WV Styrol Capacitor	2A
C414	680 pF ±5% 50 WV Styrol Capacitor	1A
C415	0.02 μF +100% -0% 25 WV Ceramic Capacitor	2B
C416	10 μF +100% -0% 10 WV Electrolytic Capacitor	2B
C417	0.02 μF ±10% 50 WV Mylar Capacitor	1B
TR401	2SC537(G) (030544-2)	1C
TR402	2SC537(G) (030544-2)	1B
TR403	2SC537(G) (030544-2)	2B
TR404	2SD187 (030814)	2B
D401	IN34A Diode (031040)	1B
D402	IN34A Diode (031040)	1B
D403	IN34A Diode (031040)	1A
D404	IN34A Diode (031040)	1A
D405	IN34A Diode (031040)	1A
D406	IN34A Diode (031040)	2A
TH401	33D26 Thermistor (032007)	2B
CR401	FP-38A Combined Capacitor Resistor (080008)	1A
CR402	FP-38A Combined Capacitor Resistor (080008)	2A
VR401	100kΩB Indicator Level Adjustment (103034)	2B
T401	19kHz Tune (424030)	1B
T402	19kHz Tune (424030)	2B
T403	38kHz Tune (424031)	1A
T404	67kHz Tune (424030)	2C
L401	4.7 mH Inductor (490003)	2C

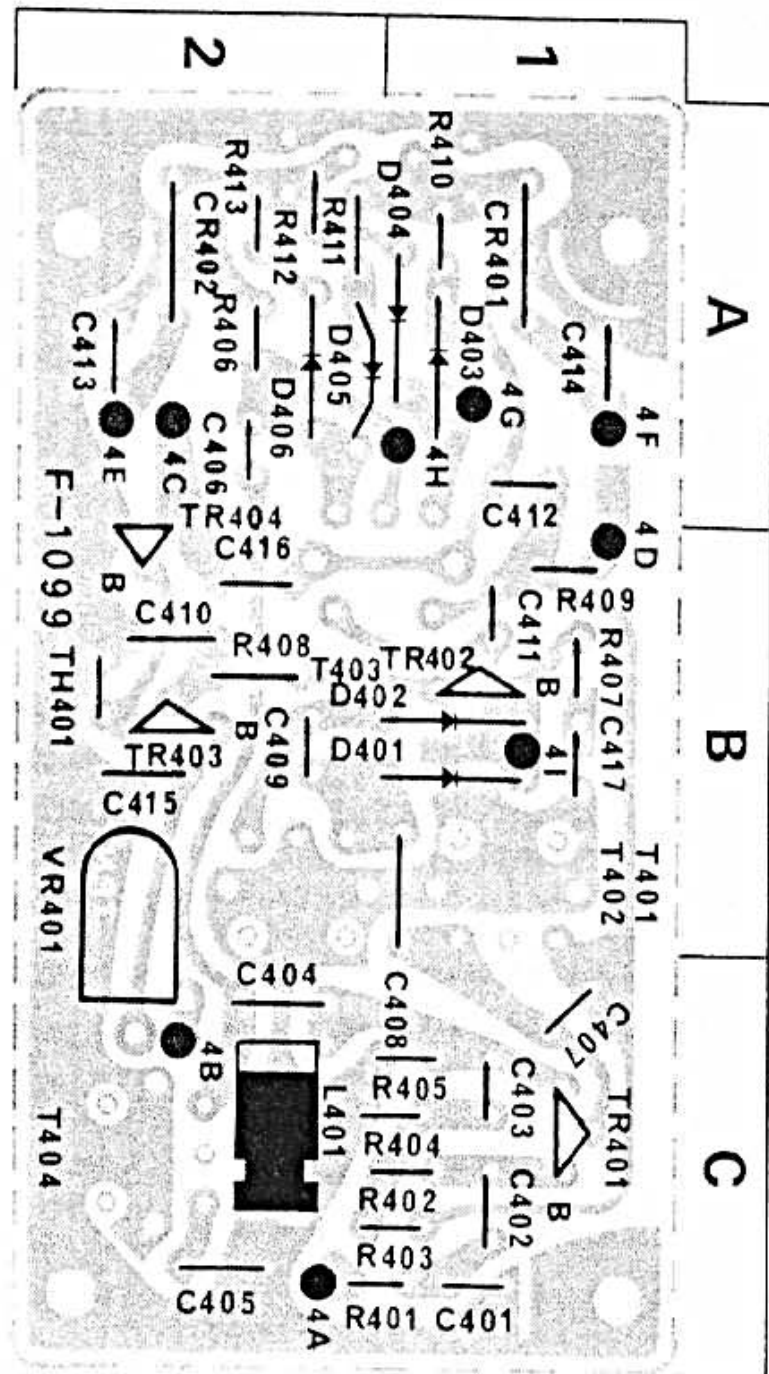

DRIVER AMP. BLOCK <F-1119B>

X	Y	Z
R801	4.7kΩ ±10% ¼W Carbon Resistor	1D
R802	4.7kΩ ±10% ¼W Carbon Resistor	1A
R803	680kΩ ±10% ¼W Carbon Resistor	1D
R804	680kΩ ±10% ¼W Carbon Resistor	1A
R805	220kΩ ±10% ¼W Carbon Resistor	1D
R806	220kΩ ±10% ¼W Carbon Resistor	1A
R807	2.2kΩ ±10% ¼W Carbon Resistor	1D
R808	2.2kΩ ±10% ¼W Carbon Resistor	1A
R809	3.3kΩ ±10% ¼W Carbon Resistor	1D
R810	3.3kΩ ±10% ¼W Carbon Resistor	1A
R811	100Ω ±10% ¼W Carbon Resistor	2D
R812	100Ω ±10% ¼W Carbon Resistor	2A
R813	1kΩ ±10% ¼W Carbon Resistor	1C
R814	1kΩ ±10% ¼W Carbon Resistor	1B
R815	12kΩ ±10% ¼W Carbon Resistor	2D
R816	12kΩ ±10% ¼W Carbon Resistor	2A
R817	3.3kΩ ±10% ¼W Carbon Resistor	1C
R818	3.3kΩ ±10% ¼W Carbon Resistor	1B
R819	56kΩ ±10% ¼W Carbon Resistor	1C
R820	56kΩ ±10% ¼W Carbon Resistor	1B
R821	27kΩ ±10% ¼W Carbon Resistor	2D
R822	27kΩ ±10% ¼W Carbon Resistor	2A

X: Parts No Y: Parts Name Z: Position of Parts

X	Y	Z
R823	330Ω ±10% ¼W Carbon Resistor	2C
R824	330Ω ±10% ¼W Carbon Resistor	2B
R825	47Ω ±10% ½W Solid Resistor	1C
R826	47Ω ±10% ½W Solid Resistor	1B
R827	180Ω ±10% ¼W Carbon Resistor	1C
R828	180Ω ±10% ¼W Carbon Resistor	1B
R829	47Ω ±10% ½W Solid Resistor	2C
R830	47Ω ±10% ½W Solid Resistor	2B
R831	180Ω ±10% ¼W Carbon Resistor	2C
R832	180Ω ±10% ¼W Carbon Resistor	2B
R833	10Ω ±10% ½W Solid Resistor	2C
R834	10Ω ±10% ½W Solid Resistor	2B
R835	10Ω ±10% ½W Solid Resistor	2C
R836	10Ω ±10% ½W Solid Resistor	2B
R837	0.5Ω 1W Wire-Wound Resistor (012026)	2C
R838	0.5Ω 1W Wire-Wound Resistor (012026)	2B
R841	10Ω ±10% ½W Solid Resistor	2D
R842	10Ω ±10% ½W Solid Resistor	2A
R843	8.2kΩ ±10% ¼W Carbon Resistor	1D
R844	8.2kΩ ±10% ¼W Carbon Resistor	1A
C801	0.15μF ±10% 50 WV Mylar Capacitor	1D
C802	0.15μF ±10% 50 WV Mylar Capacitor	1A
C803	100μF +100% -0% 10 WV Electrolytic Capacitor	1D
C804	100μF +100% -0% 10 WV Electrolytic Capacitor	1A
C805	3.3μF +100% -0% 50 WV Electrolytic Capacitor	1D
C806	3.3μF +100% -0% 50 WV Electrolytic Capacitor	1A
C807	47μF +100% -0% 50 WV Electrolytic Capacitor	1D
C808	47μF +100% -0% 50 WV Electrolytic Capacitor	1A

X	Y	Z
C809	220μF +100% -0% 10 WV Electrolytic Capacitor	2C
C810	220μF +100% -0% 10 WV Electrolytic Capacitor	2B
C811	100 pF ±10% 50 WV Ceramic Capacitor	1C
C812	100 pF ±10% 50 WV Ceramic Capacitor	1B
C813	150 pF ±10% 50 WV Ceramic Capacitor	1C
C814	150 pF ±10% 50 WV Ceramic Capacitor	1B
C815	470μF +100% -0% 35 WV Electrolytic Capacitor (020529)	2D
C816	470μF +100% -0% 35 WV Electrolytic Capacitor (020529)	2A
C817	0.047μF ±10% 50 WV Mylar Capacitor	2D
C818	0.047μF ±10% 50 WV Mylar Capacitor	2A
C819	100μF +100% -0% 50 WV Electrolytic Capacitor	2D
C820	100μF +100% -0% 50 WV Electrolytic Capacitor	2A
TR801	2SC458LG(B.C) (030531-1)	1D
TR802	2SC458LG(B.C) (030531-1)	1A
TR803	2SC968(Y) (030556)	1C
TR804	2SC968(Y) (030556)	1B
TR805	CDC8002-1(A.B.C) (030555,-1,-2)	1C
TR806	CDC8002-1(A.B.C) (030555,-1,-2)	1B
TR807	CDC9002-1(A.B.C) (030014,-1,-2)	2C
TR808	CDC9002-1(A.B.C) (030014,-1,-2)	2B
D801	SV-02 Varistor (031049)	1C
D802	SV-02 Varistor (031049)	1B
VR801	200kΩB AC Balance Adjustment (103015)	2C
VR802	200kΩB AC Balance Adjustment (103015)	2B
VR803	200ΩB DC Bias Current Adjustment (103012)	1C
VR804	200ΩB DC Bias Current Adjustment (103012)	1B

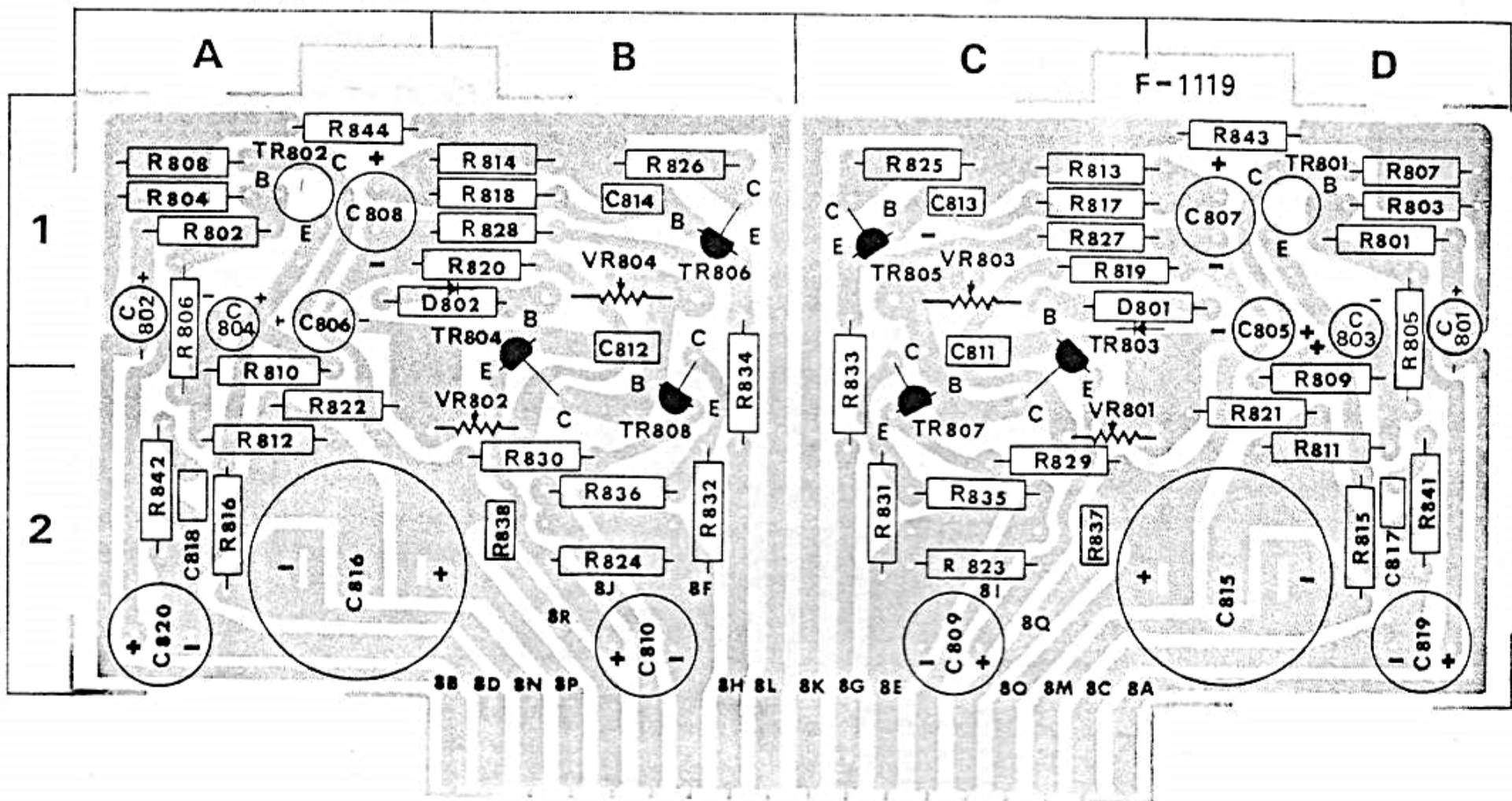

PRINTED CIRCUIT BOARDS AND PARTS LIST

OTHER PARTS AND THEIR POSITION ON CHASSIS

FM STEREO INDIKATOR BLOCK (F-1203A)

X: Parts No Y: Parts Name Z: Position of Parts

X	Y	Z
R505	150k Ω \pm 10% $\frac{1}{4}$ W Carbon Resistor	1 A
R506	8.2k Ω \pm 10% $\frac{1}{4}$ W Carbon Resistor	1 A
R507	18 Ω \pm 10% $\frac{1}{2}$ W Solid Resistor	1 A
C504	470 μ F \pm 100% 10 WV Electrolytic Capacitor	1 A
TR502	2SC828(T) (030527)	1 B
TR503	2SB324 (030311)	1 A
D501	10D-1 Diode (031034)	1 A

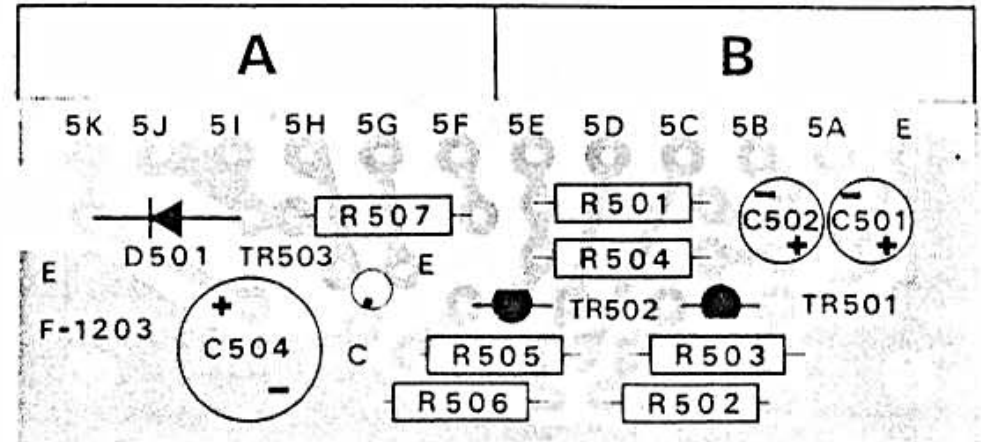

OTHER PARTS

X	Y	Z
R007	12k Ω \pm 10% $\frac{1}{4}$ W Carbon Resistor	
R008	12k Ω \pm 10% $\frac{1}{4}$ W Carbon Resistor	
R009	12k Ω \pm 10% $\frac{1}{4}$ W Carbon Resistor	
R010	12k Ω \pm 10% $\frac{1}{4}$ W Carbon Resistor	
R011	100k Ω \pm 10% $\frac{1}{4}$ W Carbon Resistor	
R012	100k Ω \pm 10% $\frac{1}{4}$ W Carbon Resistor	
R013	470k Ω \pm 10% $\frac{1}{4}$ W Carbon Resistor	
R014	470k Ω \pm 10% $\frac{1}{4}$ W Carbon Resistor	
R015	560 Ω \pm 10% $\frac{1}{2}$ W Carbon Resistor	
R016	560 Ω \pm 10% $\frac{1}{2}$ W Carbon Resistor	
R017	0.5 Ω 1 W Wire-Wound Resistor	(012026)
R018	0.5 Ω 1 W Wire-Wound Resistor	(012026)
R019	47 Ω \pm 10% $\frac{1}{4}$ W Carbon Resistor	
R020	100 Ω \pm 10% $\frac{1}{4}$ W Carbon Resistor	
R021	3.9k Ω \pm 10% $\frac{1}{4}$ W Carbon Resistor	
R022	3.9k Ω \pm 10% $\frac{1}{4}$ W Carbon Resistor	
C007	1000 μ F \pm 100% 63 WV Electrolytic Capacitor	(020548)
C008	1000 μ F \pm 100% 63 WV Electrolytic Capacitor	(020548)
C009	150 pF \pm 10% 50 WV Ceramic Capacitor	
C010	150 pF \pm 10% 50 WV Ceramic Capacitor	
C011	0.03 μ F \pm 10% 50 WV Mylar Capacitor	
C012	0.03 μ F \pm 10% 50 WV Mylar Capacitor	
C013	22 pF \pm 10% 50 WV Ceramic Capacitor	
C014	22 pF \pm 10% 50 WV Ceramic Capacitor	
C015	0.0015 μ F \pm 10% 50 WV Mylar Capacitor	
C016	0.15 μ F \pm 10% 50 WV Mylar Capacitor	
C017	0.15 μ F \pm 10% 50 WV Mylar Capacitor	
C018	0.02 μ F \pm 100% 25 WV Ceramic Capacitor	
C019	0.02 μ F \pm 100% 25 WV Ceramic Capacitor	
C020	100 μ F \pm 100% 16 WV Electrolytic Capacitor	
C021	0.0022 μ F 600 WV Oil Capacitor	
C022	0.0022 μ F 600 WV Oil Capacitor	
C023	0.0022 μ F 600 WV Oil Capacitor	
C025	3.3 μ F \pm 10% 10 WV Electrolytic Capacitor	
C026	3.3 μ F \pm 10% 10 WV Electrolytic Capacitor	

X: Parts No Y: Parts Name

X	Y	Z
TR002	2SC830(A, B) (030559, -1)	
TR003	2SC830(A, B) (030559, -1)	
TR004	2SC830(A, B) (030559, -1)	
TR005	2SC830(A, B) (030559, -1)	
PL01	6.3V 250 mA Pilot Lamp (040008)	
PL02	6.3V 250 mA Pilot Lamp (040008)	
PL03	6.3V 250 mA Pilot Lamp (040008)	
PL04	6.3V 250 mA Pilot Lamp (040008)	
PL05	6.3V 250 mA Pilot Lamp (040008)	
PL06	6.3V 250 mA Pilot Lamp (040008)	
PL07	5V 60mA Pilot Lamp (040010-1)	
F001	2A FUSE (043003)	
F002	1.5A FUSE (Quick Acting) (043010)	
F003	1.5A FUSE (Quick Acting) (043010)	
M001	Meter (090020)	
VR001	125k Ω BH \times 2 Balance, Variable Resistor (101010-1)	
VR002	250k Ω B \times 2 Volume, Variable Resistor (101037)	
VR003	100k Ω A \times 2 Tone, Variable Resistor (101038)	
VR004	100k Ω A \times 2 Tone, Variable Resistor (101038)	
VR005	10k Ω B Separation Adjustment (103019)	
S001	Rotary Switch F-3-9-4 (110321)	
S002	Lever Switch (117006)	
S003	Lever Switch (117006)	
S004	Lever Switch (117006)	
S005	Lever Switch (117006)	
S006	Power Switch (113016)	
S007	Slide Switch (111004)	
T001	Power Transformer (400048)	
MC001	Multi Connector (242002)	
	Voltage Selector (241017)	
	Voltage Selector Plug (4 P) (241019)	
	Voltage Selector Plug (6 P) (241018)	

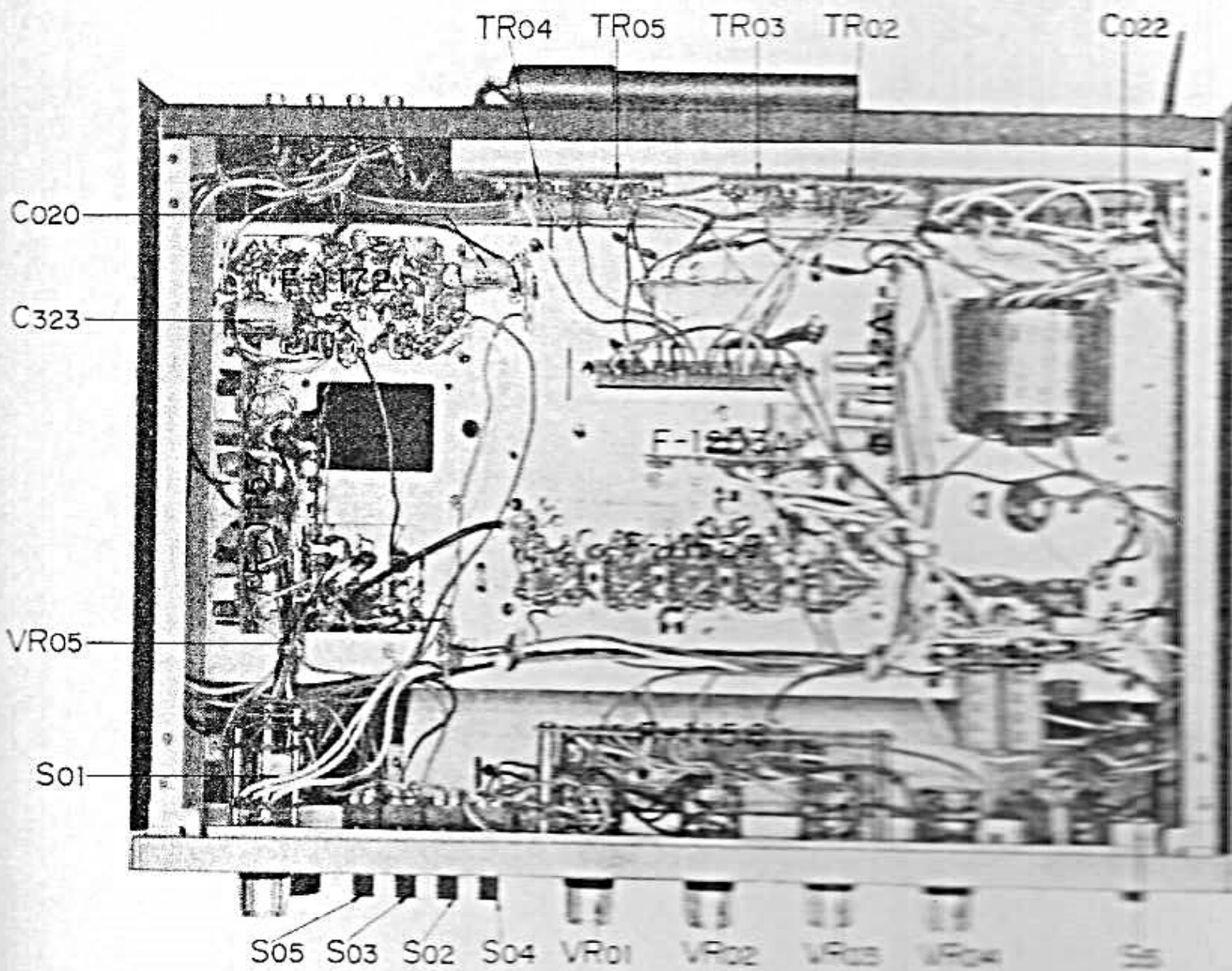
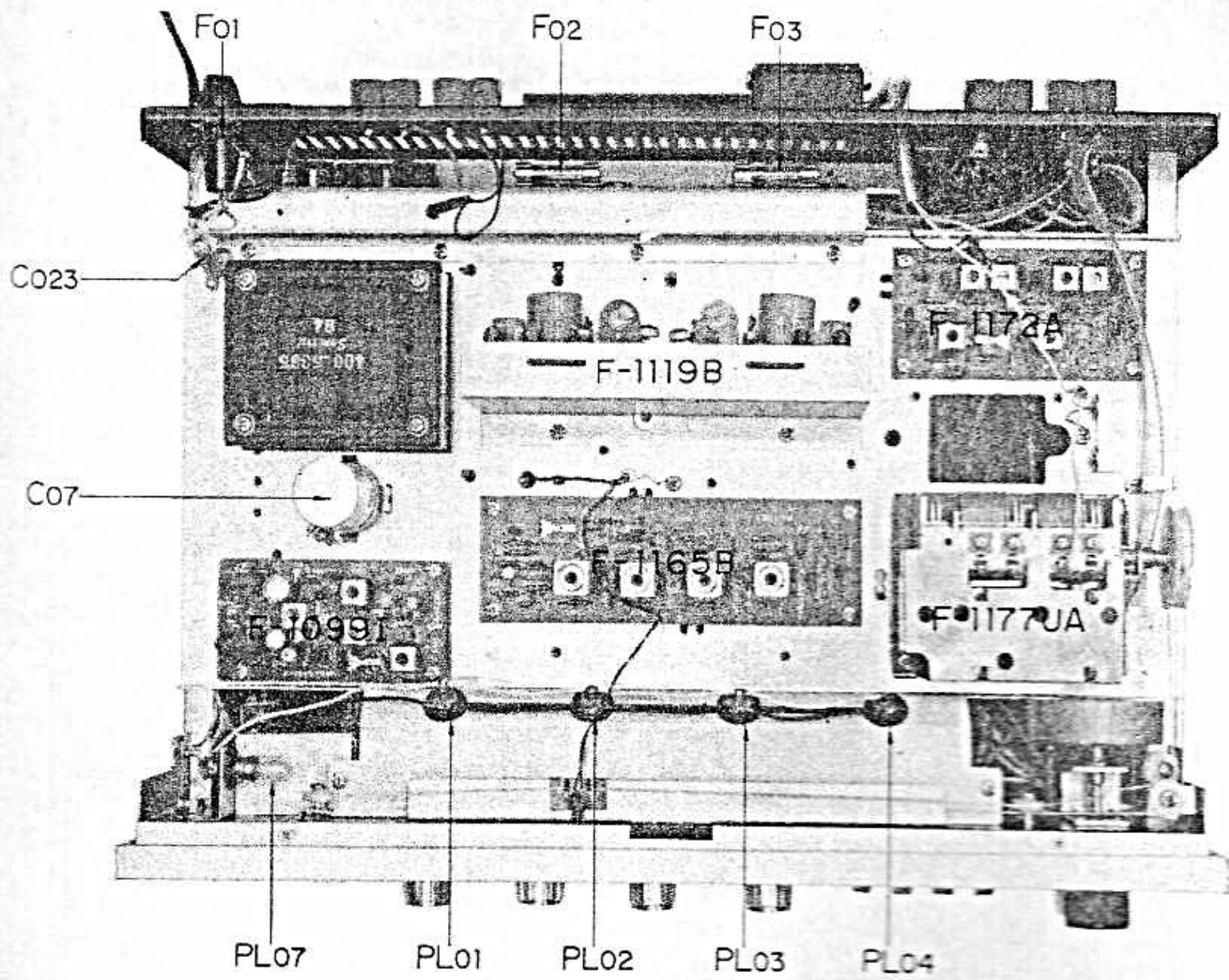



SANSUI ELECTRIC COMPANY LIMITED

Head Office ; 14-1, 2-chome, Izumi, Suginami-ku, Tokyo, Japan. TEL. 323-1111

Printed in Japan (31500M5)