



SERVICE MANUAL

AM/FM STEREO RECEIVER

SANSUI 441



Sansui

SANSUI ELECTRIC CO., LTD.

This service manual is designed for service engineers to repair, adjust, maintain and order the replacement parts of the 441 correctly. When ordering the parts, use the stock number and parts name specifically referring to the Parts Locations & Parts List. For general usage and maintenance of the unit, please refer to the Operating Instructions attached with the unit.

TABLE OF CONTENTS

<u>Section</u>	<u>Title</u>	<u>Page</u>
1.	SPECIFICATIONS	2
2.	BLOCK DIAGRAM AND LEVEL DIAGRAM	3, 4
3.	THREADING OF DIAL CORD	4
3-1.	Threading of Dial Cord	4
3-2.	Attachment of Dial Pointer	4
4.	ALIGNMENTS AND ADJUSTMENTS	5
4-1.	FM IF Alignment	5
4-2.	FM Dial Calibration, MONO Distortion and RF Alignment	6
4-3.	MPX Alignment	7
4-4.	AM IF, Dial Calibration, RF Alignment	8
5.	TROUBLESHOOTING CHART	9
5-1.	Troubleshooting on Power Supply Section	9
5-2.	Troubleshooting on Audio Section	9
5-3.	Troubleshooting on Tuner Section	9
6.	PARTS LOCATIONS AND PARTS LIST	10
6-1.	F-1506F Tuner Circuit Board	10, 11, 12
6-2.	F-1508 Pre-Main Amp & Power Circuit Board	13, 14
6-3.	Other Parts (Top Side)	15
6-4.	Other Parts (Bottom Side)	15
6-5.	Other Parts (Front Side)	16
7.	SCHEMATIC DIAGRAM	17
8.	PACKING LIST	18
9.	ACCESSORY PARTS LIST	18

1. SPECIFICATIONS

AUDIO SECTION

CONTINUOUS RMS POWER OUTPUT
 11 Watts per channel × 2
 (both channels driven)

LOAD IMPEDANCE 8Ω

POWER BAND 40 to 18,000Hz

TOTAL HARMONIC DISTORTION
 less than 1.0% (from AUX)

Music power (IHF) 44W (4Ω 1,000Hz)
 38W (8Ω 1,000Hz)

Continuous rms power output .. 12+12W (8Ω 1,000Hz)

INTERMODULATION DISTORTION
 (at rated power output, 70Hz : 7,000Hz = 4 : 1
 SMPTE method)

OVERALL (from AUX) less than 0.8%

FREQUENCY RESPONSE (at 1 Watt power output)
 OVERALL (from AUX) 25 to 30,000Hz ^{+1.0}_{-3.0}dB

EQUALIZATION (at TAPE REC output)
 RIAA Curve
 (30 to 15,000Hz ±1.5dB)

DAMPING FACTOR 20 (8Ω)

CHANNEL SEPARATION (1,000Hz, at rated power output)

PHONO better than 45dB

AUX better than 45dB

HUM AND NOISE (IHF)

PHONO better than 70dB

AUX better than 80dB

INPUT SENSITIVITY AND IMPEDANCE
 (1,000Hz, for rated power output)

PHONO 2.5mV 50kΩ
 (Max. input capability: 90mV at 0.5% distortion)

AUX 150mV 50kΩ

TAPE

PLAY Pin Jacks 150mV 50kΩ

REC/PLAY DIN Socket .. 150mV 50kΩ

RECORDING OUTPUT

TAPE

REC Pin Jacks 150mV

REC/PLAY DIN Socket .. 30mV

SWITCHES AND CONTROLS

BASS +10dB, -10dB at 50Hz

TREBLE +10dB, -10dB at 10,000Hz

LOUDNESS +10dB at 50Hz
 +8dB at 10,000Hz

TUNER SECTION

<FM>

TUNING RANGE 88 to 108MHz

SENSITIVITY (IHF) 2.5μV

TOTAL HARMONIC DISTORTION

MONO 0.4%

STEREO 0.7%

SIGNAL TO NOISE RATIO .. better than 65dB

SELECTIVITY better than 60dB

CAPTURE RATIO 2.5dB

IMAGE REJECTION better than 55dB at 98MHz

IF REJECTION better than 75dB at 98MHz

SPURIOUS RESPONSE REJECTION
 better than 65dB at 98MHz

SPURIOUS RADIATION less than 34dB

STEREO SEPARATION better than 40dB at 1kHz

FREQUENCY RESPONSE 30 to 15,000Hz

ANTENNA INPUT IMPEDANCE
 300Ω balanced,
 75Ω unbalanced

<AM>

TUNING RANGE 535 to 1,605kHz

SENSITIVITY (bar antenna) .. 53dB/m at 1MHz

SELECTIVITY better than 30dB at 1MHz

IMAGE FREQUENCY REJECTION
 better than 80dB/m at 1MHz

IF REJECTION better than 80dB/m at 1MHz

OTHERS

SEMICONDUCTORS

TRANSISTORS 16

DIODES 6

FET 1

ICs 7

ZENER DIODE 3

LED (Light Emitted Diode) .. 1

POWER REQUIREMENTS

VOLTAGE 100, 117, 220, 240V 50/60Hz

CONSUMPTION 40W (rated), 90W (max.)

DIMENSIONS 424mm (16³/₄") W,
 135mm (5³/₈") H,
 285mm (11¹/₄") D

WEIGHT 7.7kg (17.0 lbs.) net
 9.2kg (20.3 lbs.) Packed

* Design and specifications subject to change without notice for improvements.

2. BLOCK DIAGRAM AND VALUE OF EACH LEVEL

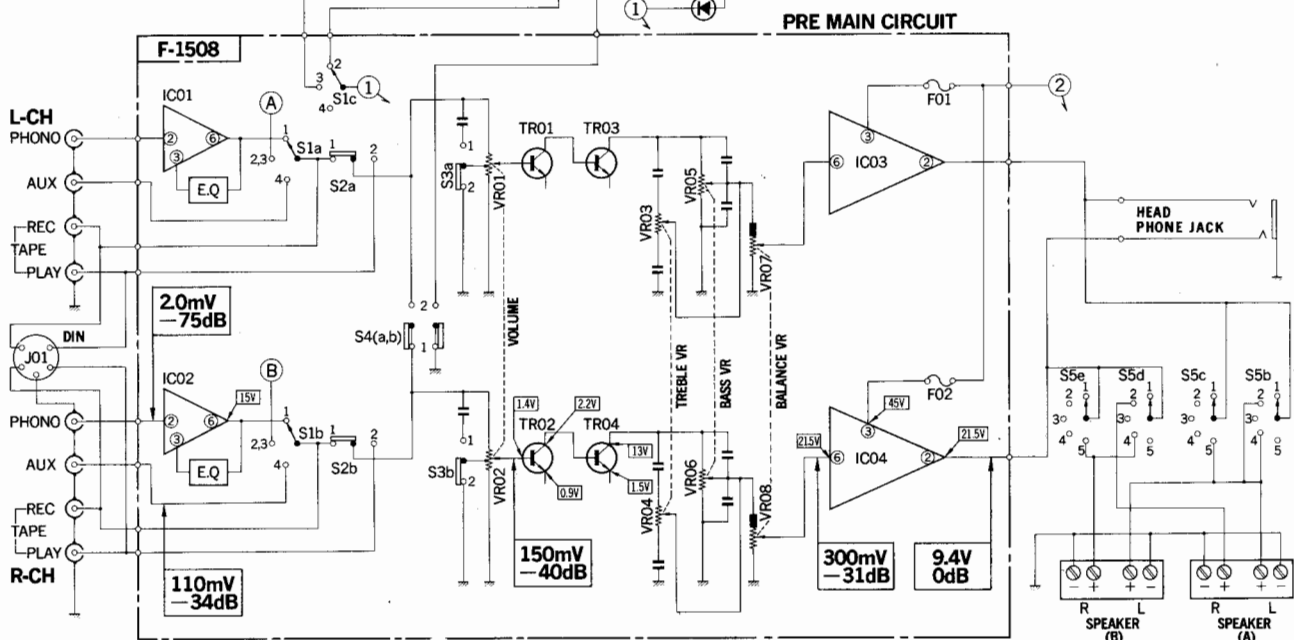
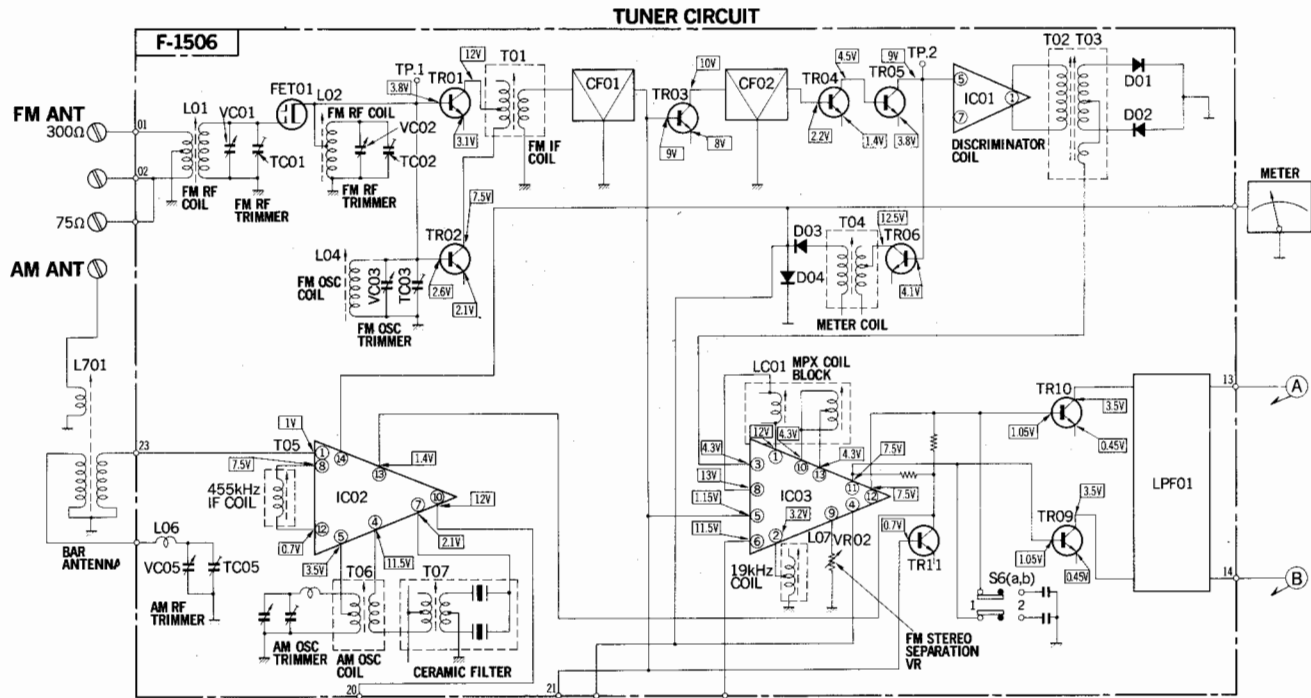

- S1(a-c): SELECTOR
 1. PHONO
 2. FM AUTO
 3. AM
 4. AUX
- S2(a, b): TAPE MONITOR
 1. OFF
 2. ON
- S3(a, b): LOUDNESS
 1. ON
 2. OFF
- S4(a, b): MODE
 1. STEREO
 2. MONO
- S5(a-e): POWER, SPEAKERS
 1. POWER OFF
 2. SPEAKER(A)
 3. SPEAKER OFF (HEAD PHONE)
 4. SPEAKER(B)
 5. SPEAKER(A+B)
- S6(a, b): FM DE-EMPHASIS
 1. 50μS
 2. 75μS

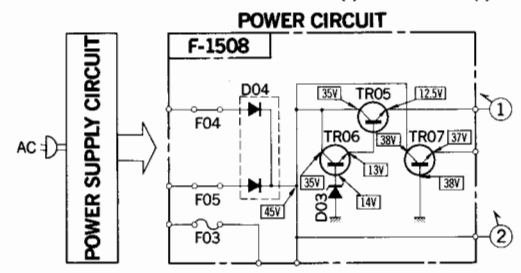

3. THREADING OF DIAL CORD

If a dial cord is cut off or slips, replace it by following procedures. As 441 uses 0.6mmφ cord, please replace it with the same type certainly.

*The length of dial cord is approximately 170cm (66 inch).

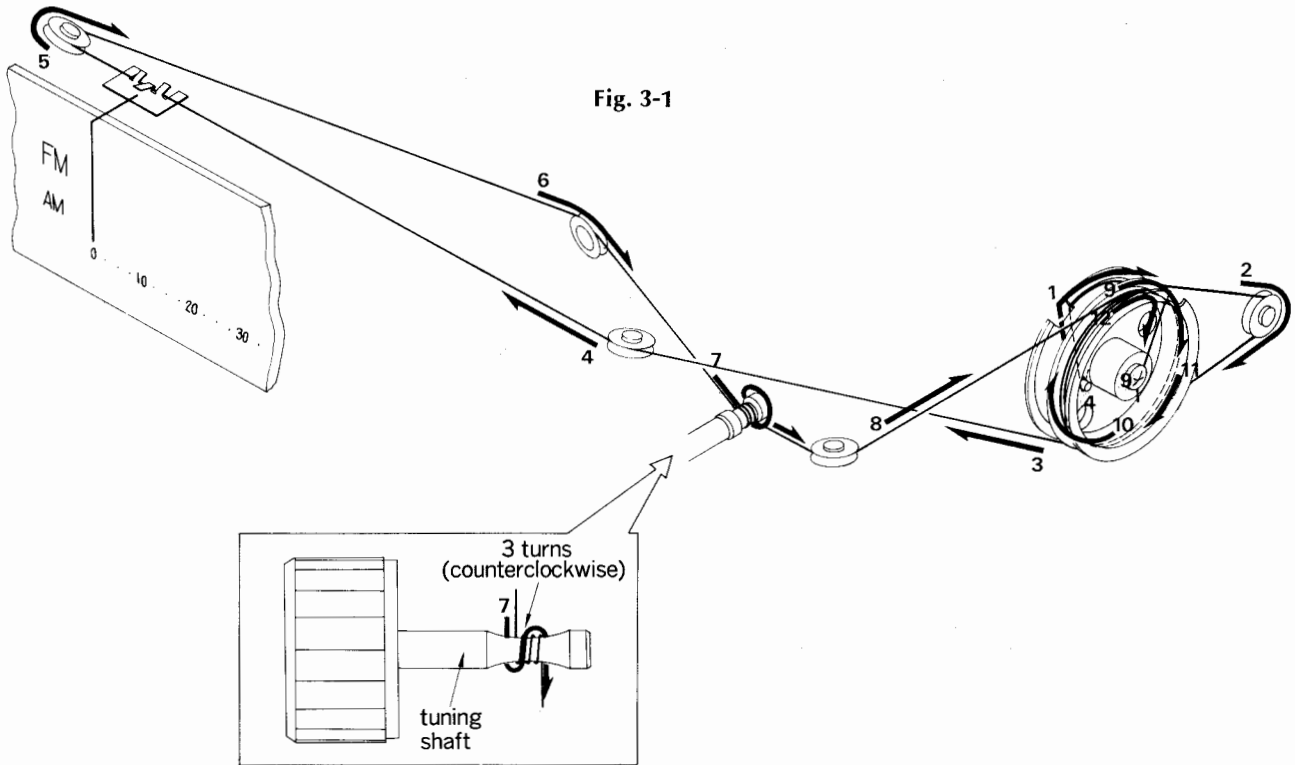

3-1. Threading of Dial Cord

Thread dial cord in numerical order from 1 to 12 as shown in Fig. 3-1.

- 1) Close the variable capacitor completely (Max. capacitance) and tie cord to number ④ screw of the dial pulley.
- 2) Thread cord in the direction of arrow from 1 to 6, then wind cord three turns around the tuning shaft counterclockwise.
- 3) Thread cord in the direction of arrow from 7 to 8, then wind it two turns on the dial pulley from 9 to 12.
- 4) After 12, tie cord to number ⑨ screw of the dial pulley.

*When you perform procedure (4) successfully, please refer to the followings.

- ① To strengthen the dial cord tension, hold around the end of cord and pull it toward the Front Panel.

- ② Then, turn tuning shaft counterclockwise, as the cord tension will be more constantly obtained.
- ③ Tie the cord to number ⑨ screw of the dial pulley (Same as procedure 4).
- 5) After procedures, lock the knots of cord with paint.

3-2. Attachment of Dial Pointer

- 1) Close the variable capacitor completely.
- 2) Set the dial pointer to "0" on dial scale and install the dial pointer ass'y.

*Confirm that the dial pointer runs smoothly on the dial scale by turning the tuning shaft.

Conditions of Level Measuring

*Value of each level in block diagram was measured by the followings.

1. MASTER VOLUMEMaximum
2. BASS, TREBLE, BALANCE volumeCenter
3. InputPHONO 2.0mV 1kHz Sine Wave
AUX 100mV 1kHz Sine Wave

(Output impedance of 600Ω at an audio oscillator)

4. Output9.4V (11W) 8Ω

Note: Each voltage value is for reference and measured by a VTVM. In some recorder, the actual voltage value is in minor difference from the reference value.

4. ALIGNMENTS AND ADJUSTMENTS

Abbreviation

Equipment

AM FM Generator Oscilloscope Genescope
 AM Standard Signal Generator AM SSG
 FM Standard Signal Generator FM SSG
 FM Stereo Generator Stereo SG
 Oscilloscope Scope
 Audio Oscillator Audio Osc.
 Distortion Meter Dist. Meter

Others

Clockwise CW.
 Counterclockwise..... CCW.
 Antenna ANT.
 Modulation..... MOD.

4-1. FM IF Alignment (See Figs. 4-4 and 4-5 on page 8)

- Note:** 1. Selector.....FM AUTO
 2. Master VolumeMinimum
 3. Output level of genescope ..After attenuator
 4. Sweepwidth.....1.5~2cm/150kHz
 5. Frequency band9.5~11.5 MHz
 6. ConnectionConnect the output of genescope to TP. 1 through 100pF ceramic capacitor.

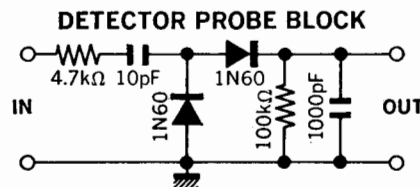
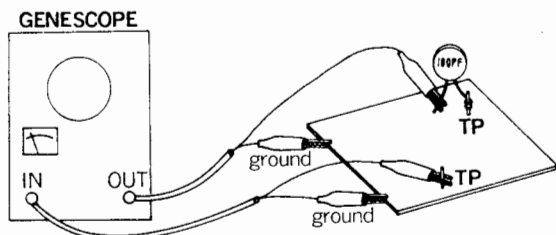

STEP	SUBJECT	FEED SIGNAL		MEASURE OUTPUT	ADJUST	ADJUST FOR	CONDITION
		FROM	TO				
1	IF Coil	Output 65dB Genescope	TP. 1 (Fig. 4-5)	TP. 2 (Fig. 4-5) Use Detector Probe	T01 (Fig. 4-5)	Max. IF waveform 1 as Fig. 4-4	
2	Discriminator Coil	Output 70dB Genescope	TP. 1 (Fig. 4-5)	TP. 3 (Fig. 4-5) Direct from Genescope	T02 (Fig. 4-5) T03 (Fig. 4-5)	Max. linearity of S curve Set the center of S curve to of waveform 1 as Fig. 4-4	
3	Meter Coil	Output 70dB Genescope	TP. 1 (Fig. 4-5)	TP. 4 (Fig. 4-5) Direct from Genescope	T04 (Fig. 4-5)	Max. IF waveform 2 Set the center of waveform 2 to of waveform 1 as Fig. 4-4	

4-2. FM Dial Calibration, MONO Distortion and RF Alignment

(See Fig. 4-5 on page 8)

- Note:** 1. Selector.....FM AUTO
 2. Master VolumeMinimum
 3. Confirm start point of dial pointer before alignment.

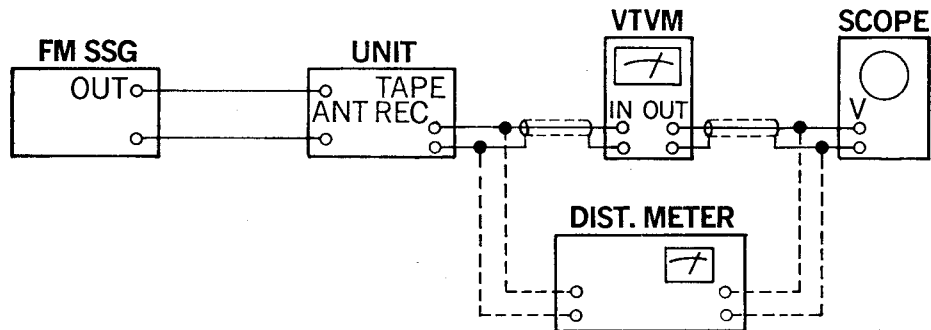

STEP	SUBJECT	FEED SIGNAL		MEASURE OUTPUT	ADJUST	ADJUST FOR	CONDITION
		FROM	TO				
1	90MHz Dial Calibration	90MHz ANT input 60dB 400Hz (100% MOD) FM SSG	FM ANT terminal 300Ω	REC OUT L or R-ch VTVM & Scope	L04 (Fig. 4-5)	Max. Output	<ul style="list-style-type: none"> ◦ Set Dial on 90MHz
2	106MHz Dial Calibration	106MHz ANT input 60dB 400Hz (100% MOD) FM SSG	Same as above	Same as above	TC03 (Fig. 4-5)	Max. Output	<ul style="list-style-type: none"> ◦ Set Dial on 106MHz
3	Confirm 90MHz Dial Calibration	Same as Step 1	Same as above	Same as above		Confirm 90MHz Dial Calibration	<ul style="list-style-type: none"> ◦ If not, repeat from Step 1
4	Confirm 106MHz Dial Calibration	Same as Step 2	Same as above	Same as above		Confirm 106MHz Dial Calibration	<ul style="list-style-type: none"> ◦ If not, repeat from Step 2
5	90MHz RF Adj.	90MHz ANT input 50dB 400Hz (100% MOD) FM SSG	Same as above	Same as above	L01 L02 (Fig. 4-5)	Max. Output	<ul style="list-style-type: none"> ◦ Tune FM SSG (Max. indication of Signal Meter)
6	106MHz RF Adj.	106MHz ANT input 50dB 400Hz (100% MOD) FM SSG	Same as above	Same as above	TC01 TC02 (Fig. 4-5)	Max. Output	<ul style="list-style-type: none"> Same as above
7	Distortion	98MHz ANT input 60dB 400Hz (100% MOD) FM SSG	Same as above	REC OUT L or R-ch Dist. meter & Scope, VTVM	T03 (Fig. 4-5)	Min. Distortion	<ul style="list-style-type: none"> ◦ Turn core T02 Max. output

4-3. MPX Alignment (See Fig. 4-5 on page 8)

- Note: 1. Selector.....FM AUTO
 2. Master VolumeMinimum

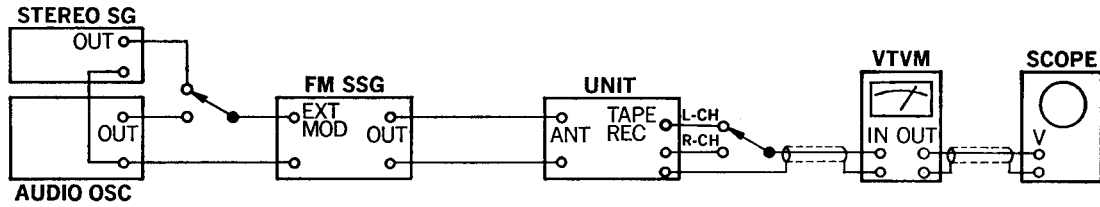

STEP	SUBJECT	FEED SIGNAL		MEASURE OUTPUT	ADJUST	ADJUST FOR	CONDITION
		FROM	TO				
1	19KHz Coil	98MHz ANT input 60dB FM SSG Pilot 19KHz (10% MOD) L-CH 1KHz (45% MOD) R-CH (0% MOD) Stereo SG	FM ANT terminal 300Ω	REC OUT L-ch VTVM & Scope	L07 (Fig. 4-5)	Max. Output	
2	Separation	Same as above	Same as above	REC OUT R-ch VTVM & Scope	VR02 (Fig. 4-5)	Min. Output	
3	Confirm Separation	98MHz ANT input 60dB FM SSG Pilot 19KHz (10% MOD) L-CH (0% MOD) R-CH 1KHz (45% MOD) Stereo SG	Same as above	REC OUT L-ch VTVM & Scope		Min. Output	◦ If less than 40dB, repeat from Step 1, 2

4-4. AM IF, Dial Calibration, RF Alignment (See Figs. 4-2, 4-3 and 4-5 on page 8)

- Note: 1. Selector.....AM
 2. Master VolumeMinimum
 3. Confirm start point of dial pointer before alignment.
 4. In case of using loop antenna, increase output of AM SSG for 26dB than bar antenna's direct input as it attenuates input sensitivity for 26dB (See Fig. 4-1)

Fig. 4-1

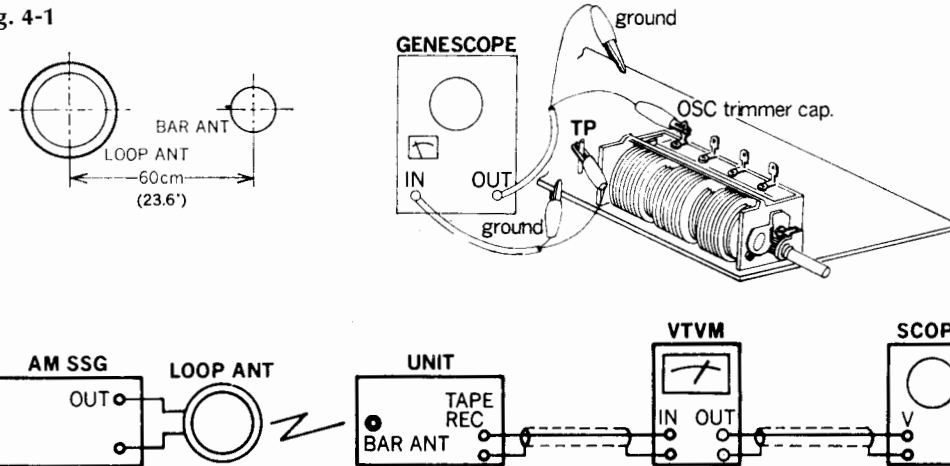

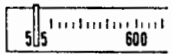
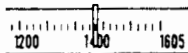
STEP	SUBJECT	FEED SIGNAL		MEASURE OUTPUT	ADJUST	ADJUST FOR	CONDITION
		FROM	TO				
1	IF coil	Output 70dB Genescope	OSC Trimmer Cap. TC 04 (Fig. 4-5)	TP. 5 (Fig. 4-5)	T07 (Fig. 4-5)	Max. IF waveform as Fig. 4-2	
2	IF coil	Output 60dB Genescope	Same as above	Same as above	T05 (Fig. 4-5)	Max. IF waveform as Fig. 4-3	
3	Confirm IF coil	Same as above	Same as above	Same as above		Max. IF waveform as Fig. 4-3	◦If not, repeat from Step 1 & 2
4	535KHz Dial Calibration	535KHz ANT input 86dB 1KHz (30% MOD) AM SSG Use loop ant.	Bar ant.	REC OUT L or R-ch VTVM & Scope	T06 (Fig. 4-5)	Max. Output	◦If broadcasting station is near, it might be used 
5	1400KHz Dial Calibration	1400KHz ANT input 86dB 1KHz (30% MOD) AM SSG Use loop ant.	Bar ant.	Same as above	TC 04 (Fig. 4-5)	Max. Output	◦Same as above 
6	Confirm 535KHz Dial Calibration	Same as Step 4	Same as above	Same as above		Max. Output	◦If not, repeat from Step 4
7	Confirm 1000KHz Dial Calibration	1000KHz ANT input 86dB 1KHz (30% MOD) AM SSG Use loop ant.	Bar ant.	REC OUT L or R-ch VTVM & Scope		Max. Output	
8	Confirm 1400KHz Dial Calibration	Same as Step 5	Same as above	Same as above		Max. Output	◦If not, repeat from Step 5
9	600KHz RF Adj.	600KHz ANT input 76dB 1KHz (30% MOD) AM SSG Use loop ant.	Same as above	Same as above	Bar ant. L701	Max. Output	
10	1400KHz RF Adj.	1400KHz ANT input 76dB 1KHz (30% MOD) AM SSG Use loop ant.	Same as above	Same as above	TC05 (Fig. 4-5)	Max. Output	

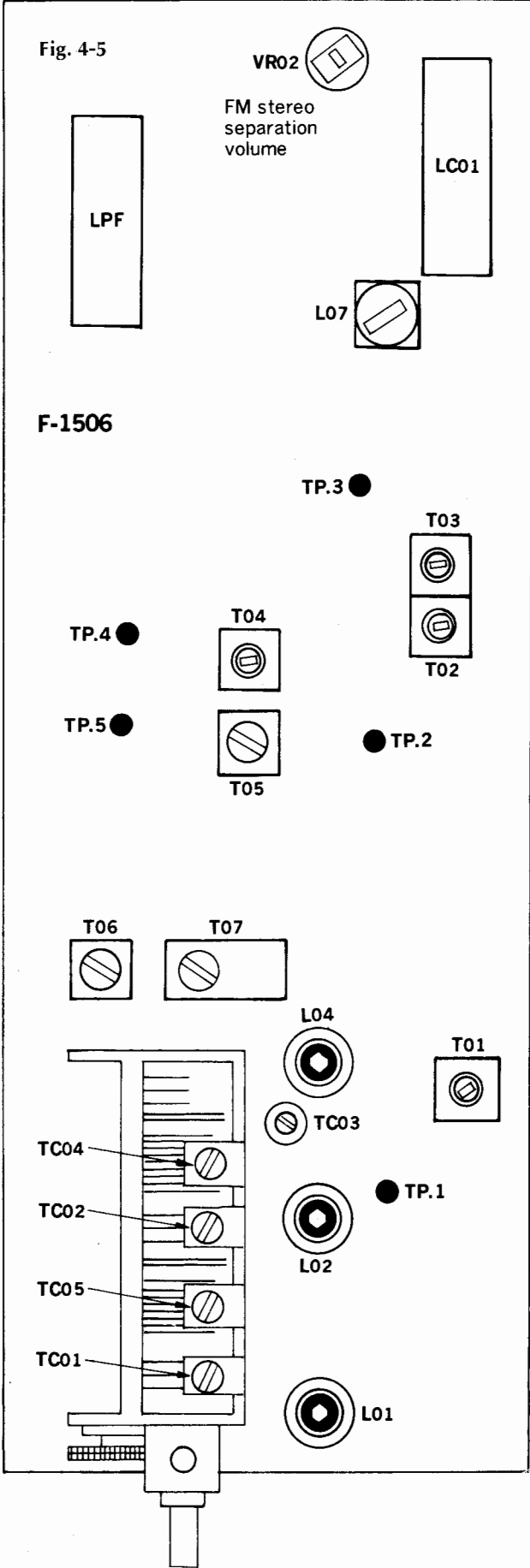
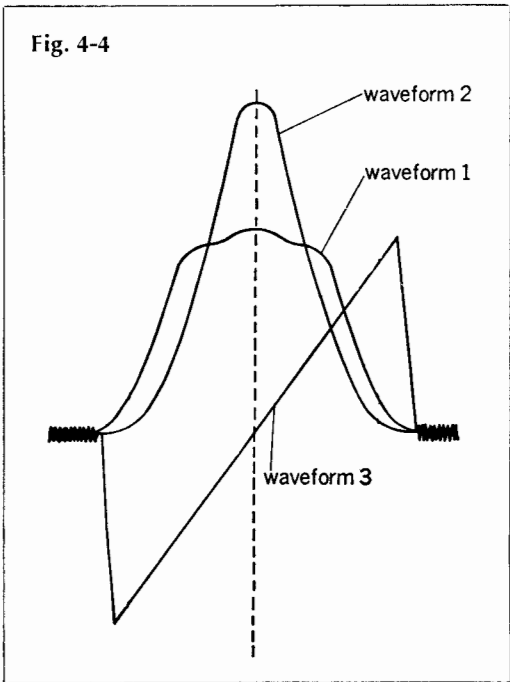
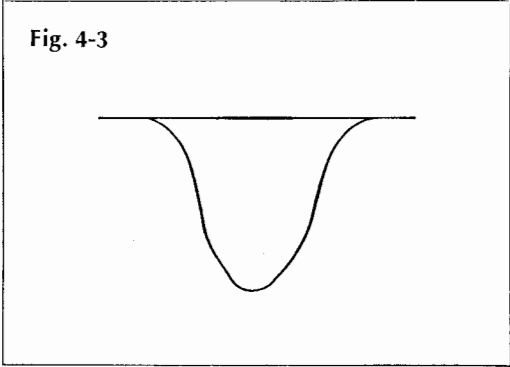
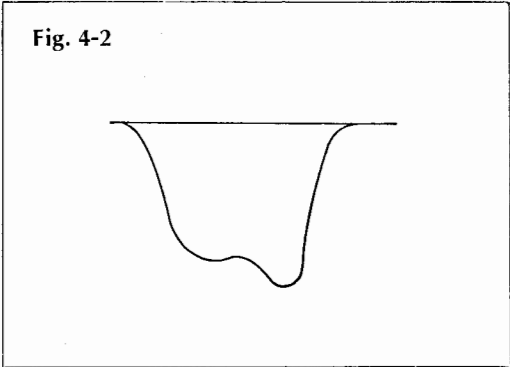

5. TROUBLESHOOTING CHART

〈Notices when servicing this unit〉

◦On Light Emitted Diode (LED)

The LED used as pilot Lamp driven by constant current has characteristics of extreme low reverse break-down voltage (DC 3V) and also it would be easily influenced by discharge voltage from capacitors in power amplifier section.

Therefore, after power switch is turned OFF and lapse of a few seconds, perform the replacement of LED.

◦Notice when replacing IC

- 1) Do not vent the leads of IC more than 3 times.
- 2) When using a soldering iron, IC should be absolutely isolated from current leakage of the iron. In order to protect IC against break-down, connect a lead wire from the iron to ground (chassis) as shown below. (Fig. 5-1)

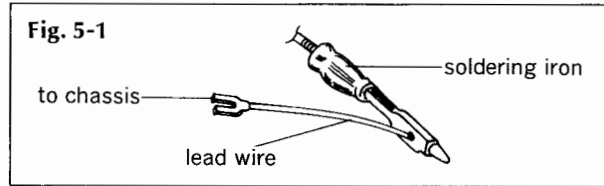

3) As IC is extremely weak against heat, use a soldering iron as shorter as possible.

◦Notice after replacing power IC

After replacing power IC, check DC bias current (20mA~80mA) on power amplifier section. If the value is under 20mA or over 80mA, the IC must be replaced again because it may be probably caused of troubles again.

5-1. Troubleshooting on Power Supply Section

Symptom	Check Point	Cause & What to Do
1. No power supplied to each section		
1-1. Each lamp not lighted		<ol style="list-style-type: none"> 1. Imperfect contact of power supply plug 2. Defective power switch S5 3. Power fuse F701 opens 4. F03 on F701 opens 5. Defective power transformer PT01
1-2. Each lamp lighted		
	1) +45V not supplied to terminal 3 of IC03, IC04 on F-1508	<ol style="list-style-type: none"> 6. F01, F02 Quick acting fuse on F-1508 opens 7. Defective D04 on F-1508
	2) +12.5V not supplied emitter of TR05 on F-1508	<ol style="list-style-type: none"> 8. Defective TR05 on F-1508 9. Defective TR06 on F-1508
	3) +37V not supplied emitter of TR07 on F-1508	<ol style="list-style-type: none"> 10. Defective D03 on F-1508 11. Defective TR07 on F-1508

5-2. Troubleshooting on Audio Section

1. Quick acting fuse open

- 1-1. After replacement, fuse opens again
 - 1) DC bias current is over 80mA ————— 1. Defective IC03 (IC04) on F-1508
- 1-2. After replacement, fuse not open
 - 1) DC bias current is not between 20mA and 80mA ————— 2. Defective IC03 (IC04) on F-1508

2. AUX inoperative

- 2-1. Both channels inoperative
 - 1) +37V not supplied to collector of TR01 (TR02) on F-1508 ————— 3. Defective power supply circuit section
- 2-2. One channel inoperative
 - 1) +37V supplied to collector of TR01 (TR02) on F-1508 —————
 4. Defective TR01, TR03 (TR02, TR03) on F-1508
 5. Imperfect contact of accessory switch and volume

Symptom	Check Point	Cause & What to Do
3. PHONO inoperative		
3-1. Both channels inoperative	<ul style="list-style-type: none"> 1) +32V not supplied to terminal 7 of IC01 (IC02) on F-1508 2) +32V supplied to terminal 7 of IC01 (IC02) on F-1508 	<ul style="list-style-type: none"> 6. Defective power supply circuit section 7. Defective turntable
3-2. One channel inoperative	<ul style="list-style-type: none"> 1) Reverse the output cords of L and R-ch from turntable <ul style="list-style-type: none"> 1-1) Inoperative channel reverse 1-2) Inoperative channel not reverse 	<ul style="list-style-type: none"> 8. Imperfect contact of the output cord 9. Defective turntable 10. Defective IC01 (IC02) on F-1508 11. Imperfect contact of SELECTOR switch

5-3. Troubleshooting on Tuner Section

1. Both FM and AM inoperative (AUDIO section operative)

1-1. Both channels inoperative	<ul style="list-style-type: none"> 1) +12V not supplied to terminal 20, 21 on F-1506 	<ul style="list-style-type: none"> 1. Imperfect contact of SELECTOR switch S1c 2. Defective power supply section
1-2. One channel inoperative AM and FM		3. Defective TR09 (TR10) on F-1509

2. FM Section

2-1. FM inoperative only	<ul style="list-style-type: none"> 1) Tune FM signal or FM broadcasting station <ul style="list-style-type: none"> 1-1) Signal meter inoperative 1-2) Signal meter inoperative (Interstation noise too low compared with proper unit) 	<ul style="list-style-type: none"> 4. Defective FET01 on F-1506 5. Defective TR01~TR05 on F-1506 6. Defective CF01, CF02 on F-1506 7. Defective L01~L04 on F-1506 8. Defective T01 on F-1506 9. Defective IC01 on F-1506 10. Defective T02, T03 on F-1506 11. Defective D01, D02 on F-1506
2-2. Signal meter inoperative (FM broadcasting sound can be heard)		<ul style="list-style-type: none"> 12. Defective TR06 on F-1506 13. Defective T04 on F-1506 14. Defective D03, D04 on F-1506 15. Defective signal meter
2-3. No channel separation on FM stereo broadcasting *Confirm that SELECTOR switch is set to FM AUTO	<ul style="list-style-type: none"> 1) Indicator lamp not lighted 2) Indicator lamp lighted 	<ul style="list-style-type: none"> 16. Defective IC03 on F-1506 17. Defective L07 on F-1506 18. Defective Volume VR02 on F-1506 19. Defective LED01 on F-1506 20. L07 out of adjustment on F-1506 21. VR02 out of adjustment on F-1506

3. AM Section

3-1. AM inoperative	<ul style="list-style-type: none"> 1) Interstation noise change by touching the terminal 23 on F-1506 (No change) 2) Interstation noise change by touching the terminal 23 on F-1506 (Increase) 	<ul style="list-style-type: none"> 22. Defective IC02 on F-1506 23. Defective T05 on F-1506 24. Defective T06 on F-1506 25. Defective TR11 on F-1506 26. Defective bar antenna 27. Variable capacitor shorted
3-2. Signal meter inoperative		<ul style="list-style-type: none"> 28. Defective IC02 on F-1506 29. Defective signal meter

6. PARTS LOCATIONS AND PARTS LISTS

6-1. F-1506F Tuner Circuit Board (Stock No. 7520970 Complete Circuit Board F-1506F)

Parts List

Parts No.	Stock No.	Description	Position
TR01	0305801	2SC1047B (G)	1 A
TR02	0305790, 1	2SC930 (C, D)	1 B
TR03	0306112, 3	2SC738 (C, D)	1 B
TR04	0306112, 3	2SC738 (C, D)	1 B
TR05	0306112, 3	2SC738 (C, D)	1 B
TR06	0306112, 3	2SC738 (C, D)	1 C
TR07	0305731, 2	2SC711 (E, F)	2 C
TR08	0305731, 2	2SC711 (E, F)	2 C
TR09	0306090, 1	2SC1312 (F, G)	2 D
TR10	0306090, 1	2SC1312 (F, G)	2 D
TR11	0305731, 2	2SC711 (E, F)	1 C
IC01	0360120	μ PC555H	1 B, C
IC02	0360150	HA1151	1, 2 B
IC03	0360080	HA1120	1 D
FET01	0370131, 2	3SK41 (L, K) FET	1 A
D01	0311060	1N60P	1 C
D02	0311060	1N60P	1 C
D03	0311160	1S2473D	2 C
D04	0340090	DS430	2 C
T01	4235930	FM IF Coil	1 A, B
T02	4235750	FM Discriminator Coil	1 C
T03	4235760		1 C
T04	4235940		1, 2 C
T05	4230620	AM IF Coil	1, 2 B C
T06	4220550	AM OSC Coil	2 B
T07	0910270	Ceramic Filter	1, 2 B
L01	4200560	FM ANT Coil	1 A
L02	4210300	FM RF Coil	1 A
L03	4010120	Peaking Coil	1 A
L04	4220530	FM OSC Coil	1 A, B
L05	4290530	Peaking Coil	2 A, B
L06	4900100	Inductor Coil	1 A
L07	4240720	19kHz MPX Coil	1 D
LC01	4240710	MPX Coil Block	2 D
CF01	0910150	Ceramic Filter	1 B
CF02	0910150		1 B
LPF01	0910220	Low Pass Filter	2 D
VC	1220170	Variable Capacitor	1, 2 B
TC03	1230090	Trimmer Capacitor	1 A
VR02	1035070	1k Ω (B) FM STEREO Separation VR	1 D
C01	0669369	8.2pF	1 A
C02	0650102	1000pF	1 A
C03	0659015	2200pF	1 A
C04	0657223	22000pF	1 A
C05	0659015	2200pF	1 A
C06	0669002	3.9pF	1 A
	0669205	3.9pF	1 A
C07	0669370	10pF	1 A
C08	0659015	2200pF	1 A
C09	0650102	1000pF	1 A

Parts No.	Stock No.	Description	Position
C10	0661220	22pF	1 A
	0669221	22pF	1 A
C11	0657223	22000pF	1 A
C12	0669370	10pF	1 A, B
C13	0669200	1pF	1 A
C14	0669370	10pF	1 A
C15	0669370	10pF	1 B
C16	0669370	10pF	1 B
C17	0657223	22000pF	1 B
C18	0657223	22000pF	1 A
C19	0657473	47000pF	1 B
C20-28	0657223	1000pF	1 B, 1 C
C29, 30	0660101	100pF	1 C
C31	0512100	10 μ F	16V E.C.
C31	0512100	10 μ F	1 C
C33, 34	0660101	100pF	1 C
C36-39	0657223	22000pF	50V C.C.
C36-39	0657223	22000pF	1 C, 2 C
C40	0519103	0.47 μ F	50V E.C.
C42	0657223	22000pF	50V C.C.
C43	0601106	0.001 μ F	50V M.C.
C44	0515109	1 μ F	50V E.C.
C45	0515339	3.3 μ F	2 C
C46	0601107	0.01 μ F	2 B
C47	0601477	0.047 μ F	50V M.C.
C48	0601107	0.01 μ F	2 B
C49	0512101	100 μ F	16V E.C.
C50	0601106	0.001 μ F	50V M.C.
C51	0657223	22000pF	50V C.C.
C52	0669215	15pF	2 B
C53	0620361	360pF	50V P.C.
C54	0601107	0.01 μ F	50V M.C.
C55	0512100	10 μ F	16V E.C.
C56	0513479	4.7 μ F	25V E.C.
C57	0515109	1 μ F	1 D
C58	0515109	1 μ F	50V E.C.
C59	0600826	0.0082 μ F	50V M.C.
C60	0600826	0.0082 μ F	2 D
C61	0512101	100 μ F	16V E.C.
C62	0601108	0.1 μ F	50V M.C.
C63	0601108	0.1 μ F	2 D
C70	0519101	1 μ F	50V E.C.
C71	0519101	1 μ F	2 D
C72	0650102	1000pF	50V C.C.
C73	0510470	47 μ F	6.3V E.C.
C74	0601477	0.047 μ F	50V M.C.
C75	0513479	4.7 μ F	25V E.C.
C76	0600157	0.015 μ F	50V M.C.
C77	0600157	0.015 μ F	2 D
C78	0513479	4.7 μ F	25V E.C.
C79	0629001	6800pF	50V P.C.

Abbreviations

C.R. : Carbon Resistor	BP.E.C.: Bi-Polar Electrolytic Capacitor
S.R. : Solid Resistor	C.C. : Ceramic Capacitor
Ce.R. : Cement Resistor	Mi.C. : Mica Capacitor
M.R. : Metallized Film Resistor	O.C. : Oil Capacitor
M.C. : Mylar Capacitor	P.C. : Polystyrene Capacitor
E.C. : Electrolytic Capacitor	T.C. : Tantalum Capacitor

F-1506F Conductor Side

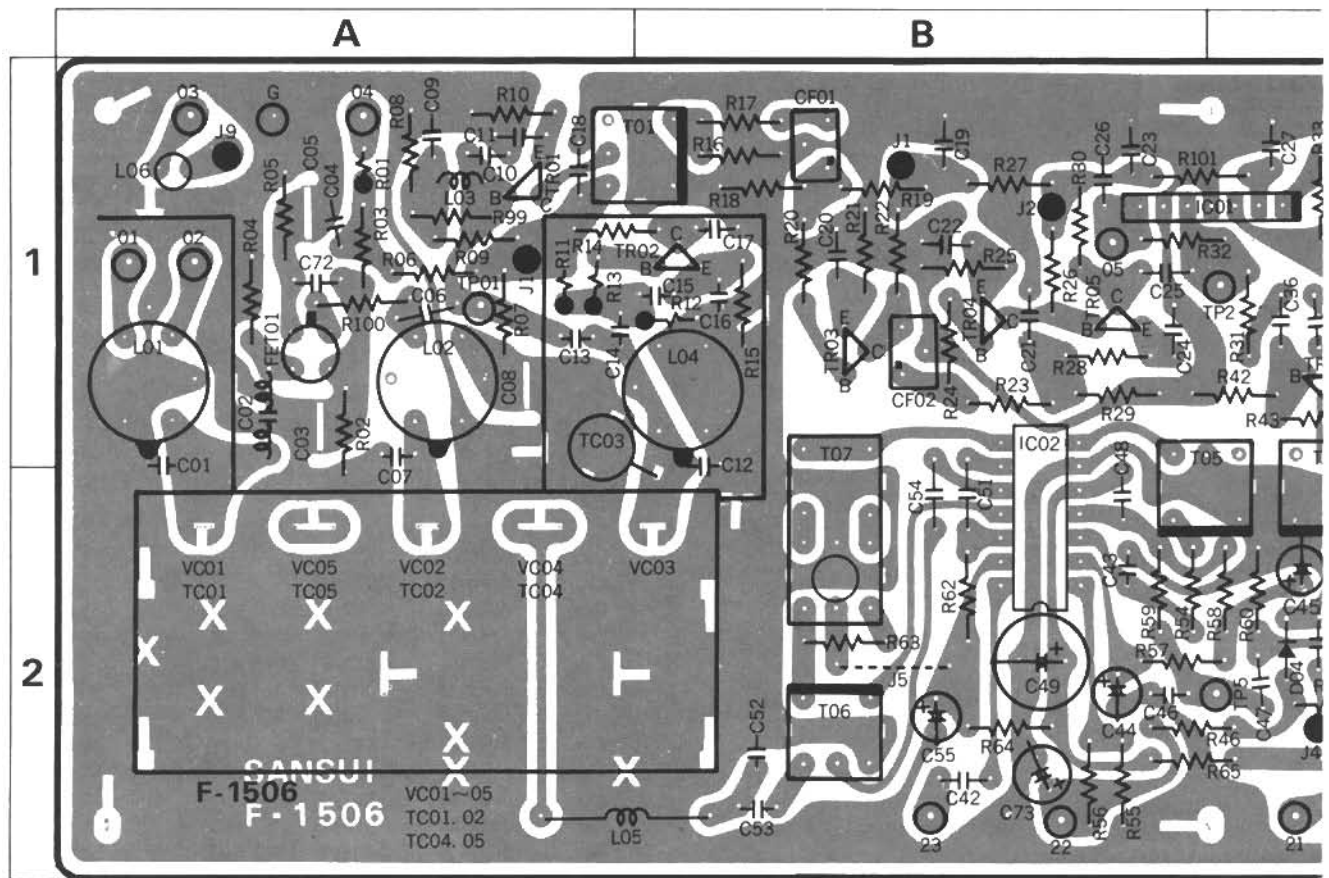

Parts List

Parts No.	Stock No.	Description	Position
R02	0113394	390kΩ	1 A
R03	0113103	10kΩ	1 A
R04	0113104	100kΩ	1 A
R05	{0113101 0113151}	{100Ω (35K41 (L)) 150Ω (35K41 (K))}	1 A
R06	0113105	1MΩ	1 A
R07	0113220	22Ω	1 A
R08	0113562	5.6kΩ	1 A
R09	0113123	12kΩ	1 A
R10	0113332	3.3kΩ	1 A
R11	0116822	8.2kΩ	1 A
R12	0116222	2.2kΩ	1 B
R13	0116220	22Ω	1 A
R14	0113222	2.2kΩ	1 A, B
R15	0113102	1kΩ	1 B
R16	0113471	470Ω	1 B
R17	0113221	220Ω	1 B
R18	0113392	3.9kΩ	1 B
R19	0113152	1.5kΩ	1 B
R20	0113101	100Ω	1 B
R21	0113182	1.8kΩ	1 B
R22	0113471	470Ω	1 B
R23	0113681	680Ω	1 B
R24	0113101	100Ω	1 B
R25	0113271	270Ω	1 B
R26	0113152	1.5kΩ	1 B
R27	0113220	22Ω	1 B

Parts No.	Stock No.	Description	Position
R28	0113271	270Ω	1 B
R29	0113391	390Ω	1 B
R30	0113681	680Ω	1 B
R31	0113332	3.3kΩ	1 C
R32	0113222	2.2kΩ	1 B, C
R33	0113682	6.8kΩ	1 C
R34	0113331	330Ω	1 C
R35	0113102	1kΩ	1 C
R36	0113102	1kΩ	1 C
R37	0113101	100Ω	1 C
R38	0113471	470Ω	1 C
R39	0113103	10kΩ	1 C
R40	0113103	10kΩ	1 C
R42	0113103	10kΩ	1 C
R43	0113183	18kΩ	1 C
R44	0113102	1kΩ	1 C
R45	0113101	100Ω	1, 2 C
R46	0113182	1.8kΩ	2 B, C
R47	0113682	6.8kΩ	2 C
R48	0113104	100kΩ	2 C
R49	0113104	100kΩ	2 C
R51	0113220	22Ω	2 C
R53	0113471	470Ω	1 C
R54	0113101	100Ω	2 B
R55	0113122	1.2kΩ	2 B
R56	0113152	1.5kΩ	2 B
R57	0113103	10kΩ	2 B, C

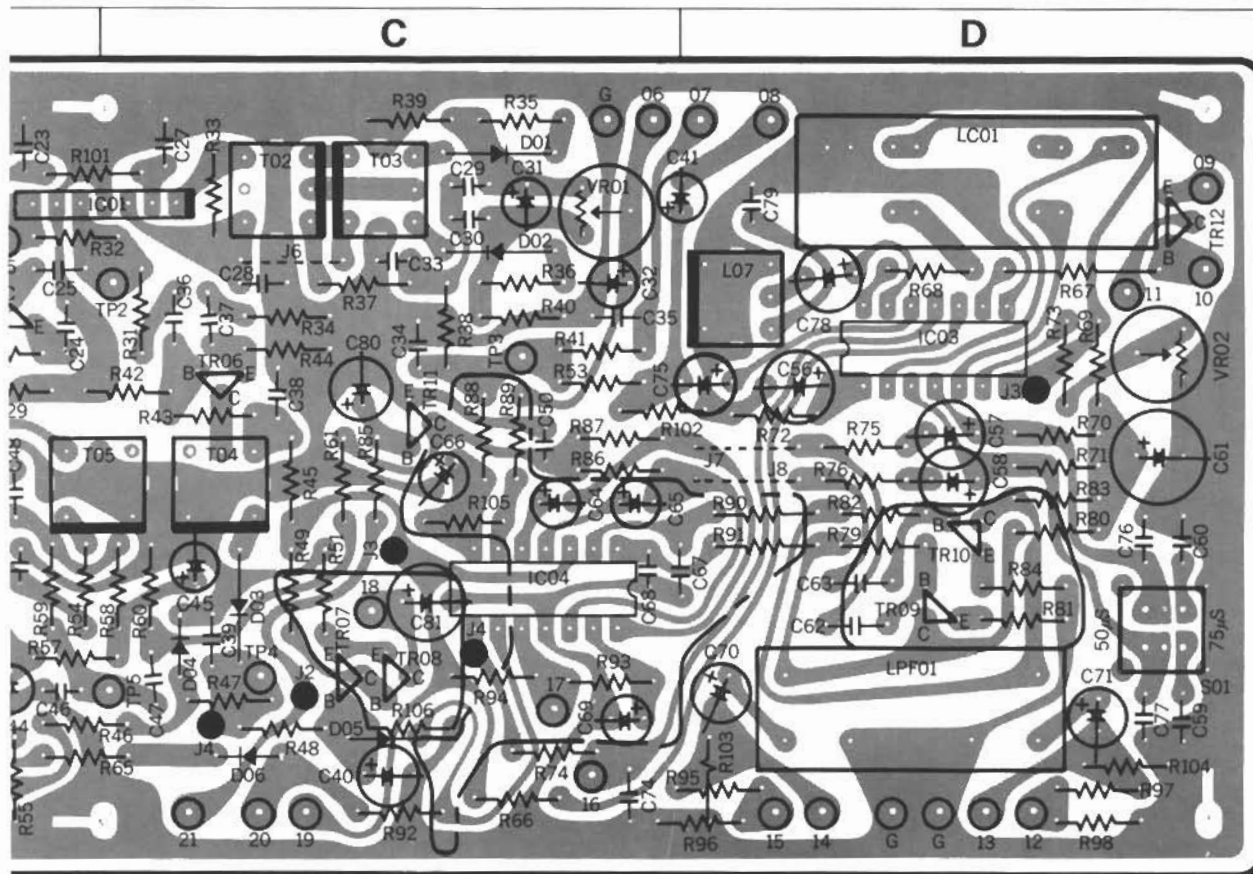

Parts No.	Stock No.	Description	Position
R58	0113103	10kΩ	2C
R59	0113182	1.8kΩ	2B
R60	0113473	47kΩ	2C
R61	0113153	15kΩ	1, 2C
R62	0113392	3.9kΩ	2B
R63	0113224	220kΩ	2B
R64	0113151	150Ω	2B
R65	0113101	100Ω	2B, C
R66	0113334	330kΩ	2C
R67	0171471	470Ω	1D
R68	0113151	150Ω	1D
R69	0113101	100Ω	1D
R70	0113332	3.3kΩ	1D
R71	0113332	3.3kΩ	2D
R72	0113472	4.7kΩ	1D
R73	0113151	150Ω	1D
R74	0113104	100kΩ	2C
R75	0113223	22kΩ	1D
R76	0113223	22kΩ	2D
R77	0113101	100Ω	
R78	0113101	100Ω	
R79	0113684	680kΩ	2D
R80	0113332	3.3kΩ	2D
R81	0113181	180Ω	2D
R82	0113684	680kΩ	2D
R83	0113332	3.3kΩ	2D
R84	0113181	180Ω	2D

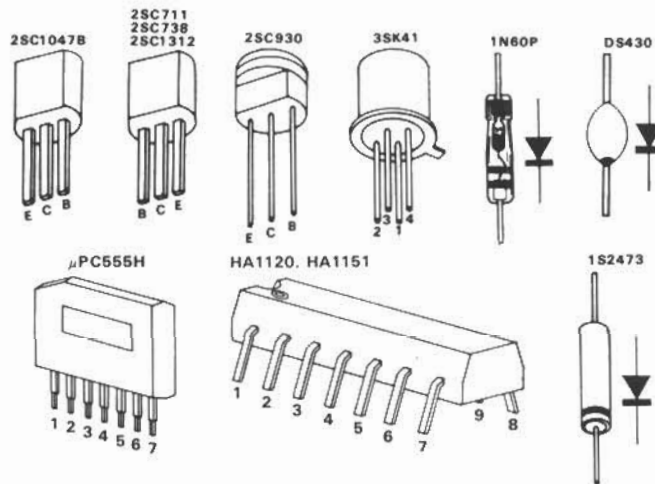

Parts No.	Stock No.	Description	Position
R85	0113472	4.7kΩ	1, 2C
R86	0113563	56kΩ	2C
R87	0113563	56kΩ	1C
R99	0113101	100Ω	1A
R100	0113470	47Ω	1A
R101	0113220	22Ω	1/4 W S.R.
R102	0113123	12kΩ	1B, C
R103	0113332	3.3kΩ	1C, D
R104	0113332	3.3kΩ	2D
R701	0113122	1.2kΩ	2D
S01	1110270	Slide Switch	2D

Conductor Side

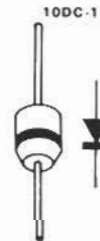
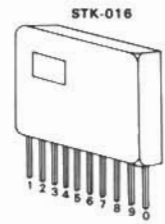
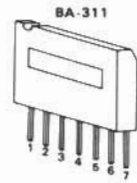
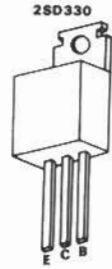
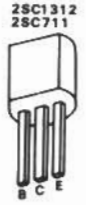
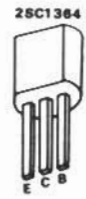
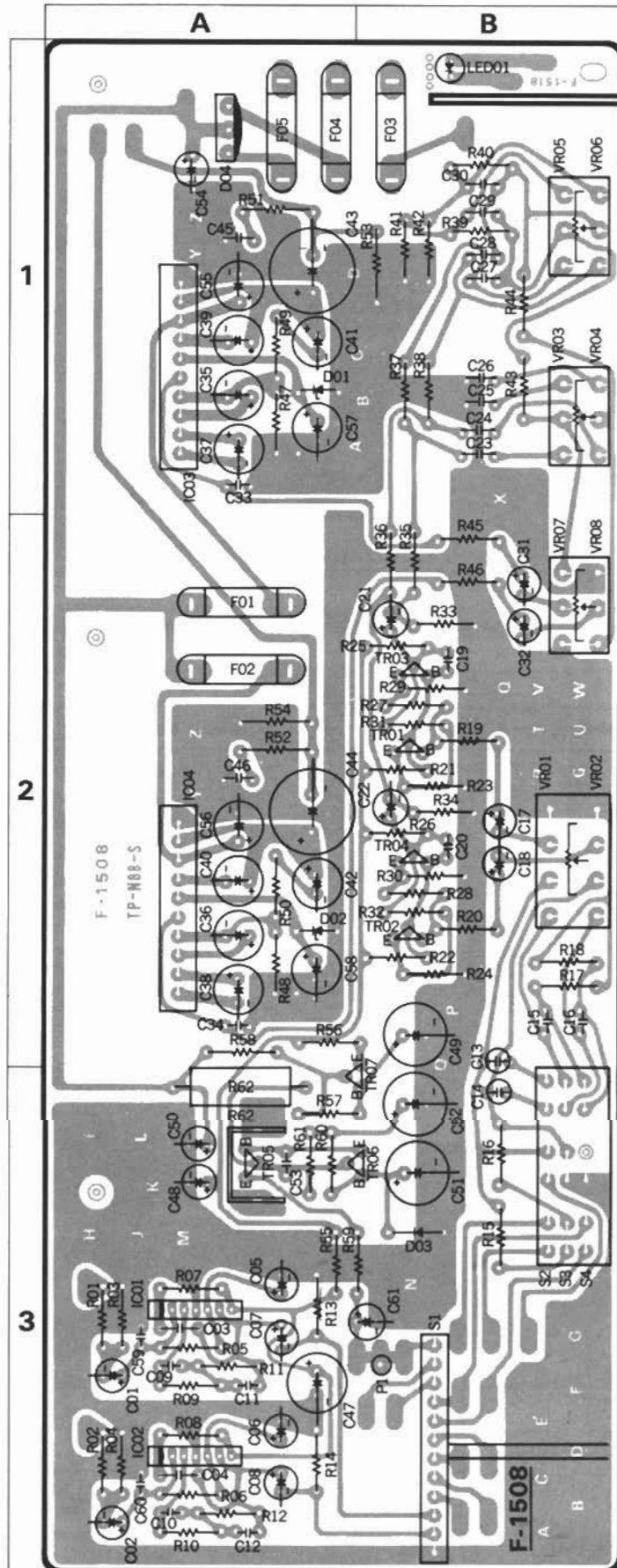

6-3. Other Parts (Top Side)

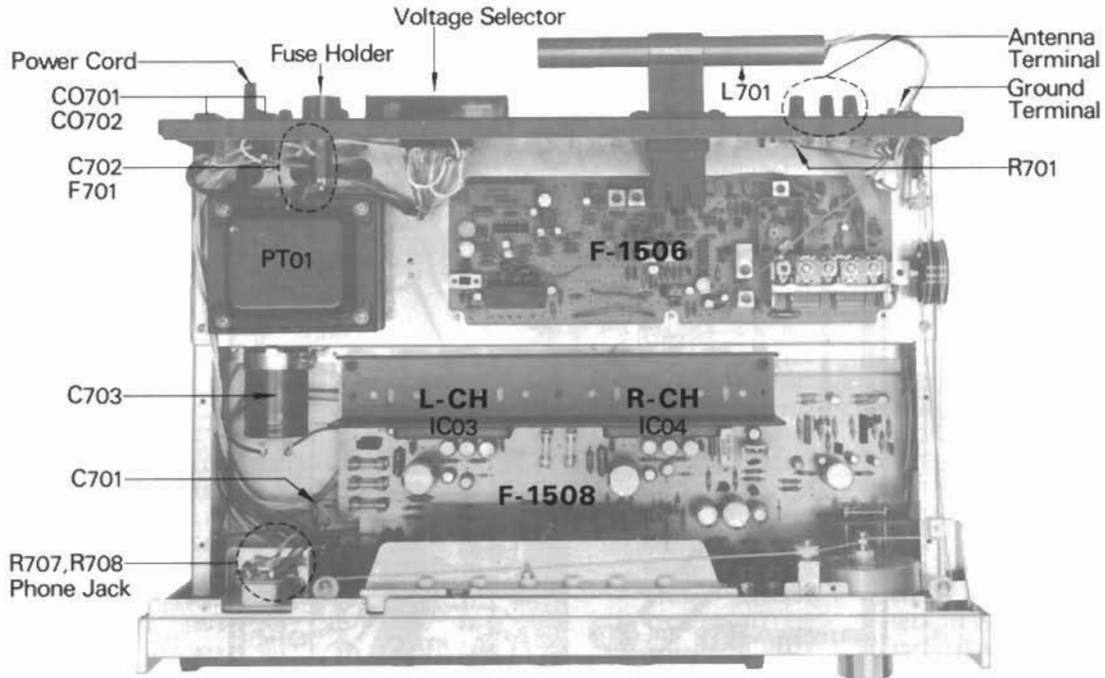

Top Side Parts List

Parts No.	Stock No.	Description
IC03	0360130	STK-016
IC04	0360130	STK-016
		Power IC
C701	0659802	0.0047 μ F
C702	0659802	0.0047 μ F
		1.4kV C.C.
C703	0559351	2200 μ F
		50V E.C.
R701	0113122	1.2k Ω
		1/4W C.R.
R707	0103271	270 Ω
		1/2W C.R.
R708	0103271	270 Ω
		1/2W C.R.
L701	4200650	Bar Antenna
F701	{ 2300060 0431220	{ Fuse Holder 1A (220~240V)
		Power, Fuse

Parts No.	Stock No.	Description
F701	0431232	1.5A (100~117V) Power, Fuse
CO701	2450050	AC Outlet
CO702	2450050	AC Outlet
PT01	4002100	Power Transformer
PU01	{ 2410080 2410090 2210190 2230051 2430200 3800020	{ Voltage Selector, Socket Voltage Selector, Plug Antenna Terminal Ground Terminal Phone Jack Power Cord

6-4. Other Parts (Bottom Side)

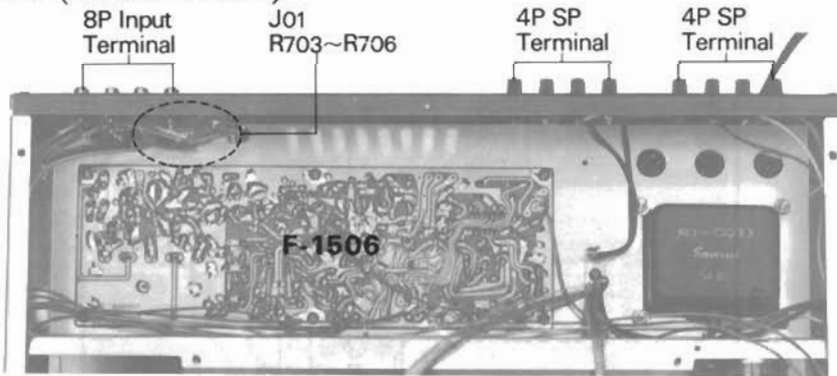

Bottom Side Parts List

Parts No.	Stock No.	Description
R703	0107394	390k Ω
R704	0107394	390k Ω
R705	0107104	100k Ω
R706	0107104	100k Ω
		1/4W C.R.

Parts No.	Stock No.	Description
J01	2430040	DIN Connector
	2210200	4P Speaker Terminal
	2200340	8P Input Terminal

6-5. Other Parts (Front Side)

Parts No.	Stock No.	Description
1	5101161	Binding Head Screw, M4×6
2	5006320	Bonnet
3	5102843	Flat Countersunk Head Screw, M3×6
4	5176052	Nut, headphone jack
5	5317730	M-3 Type Knob, POWER, SPEAKER and SELECTOR
6	5317740	S-3 Type Knob, tone control
7	5317720	L-1 Type Knob, VOLUME
9	5326420	Button, LOUDNESS, MONO and TAPE MONITOR
10	5317820	T-6 Type Knob, TUNING
11	5110781	Hex. Nut, M9
12	5120184	Plain Washer, 9φ
13	{ 7006980 5047760	Front Panel Smoked Plate
14	2430200	Headphone Jack
15	1101581	Rotary Switch Y-1-2-5, POWER and SPEAKER
16	1011030	100kΩ(A)×2 BASS and TREBLE volume
17	1011040	250kΩ(B)×2 (MN) BALANCE volume
18	1011020	250kΩ(B)×2 VOLUME
19	1130870	Push Switch
20	1101570	Rotary Switch F-1-3-4, SELECTOR
21	5236490	Spacer Nut, M9
23	7036400	Tuning Ass'y
24	5416361	Dial Pointer Ass'y
25	5407690	Dial Scale
26	5109122	Binding Head Screw, M3×8
27	{ 2591920 0319010	LED Circuit Board F-1518 LED (FM Stereo Indicator)
28	5110241	Hex. Nut, M3
29	5120141	Plain Washer, 3φ
30	0420040	Fuse Type Lamp (7V, 300mA)
31	5058150	Indicator Box
32	5109122	Binding Head Tapping Screw, M3×8
33	5269700	Meter Holder
34	0420040	Fuse Type Lamp (7V, 300mA)
35	{ 7726060 4300610, 1	Meter Lamp Unit B Signal Meter
36	5109222	Binding Head Tapping Screw, M3×8
37	5101164	Binding Head Screw, M4×12
38	5516911	Foot
39	5058200	Bottom Plate

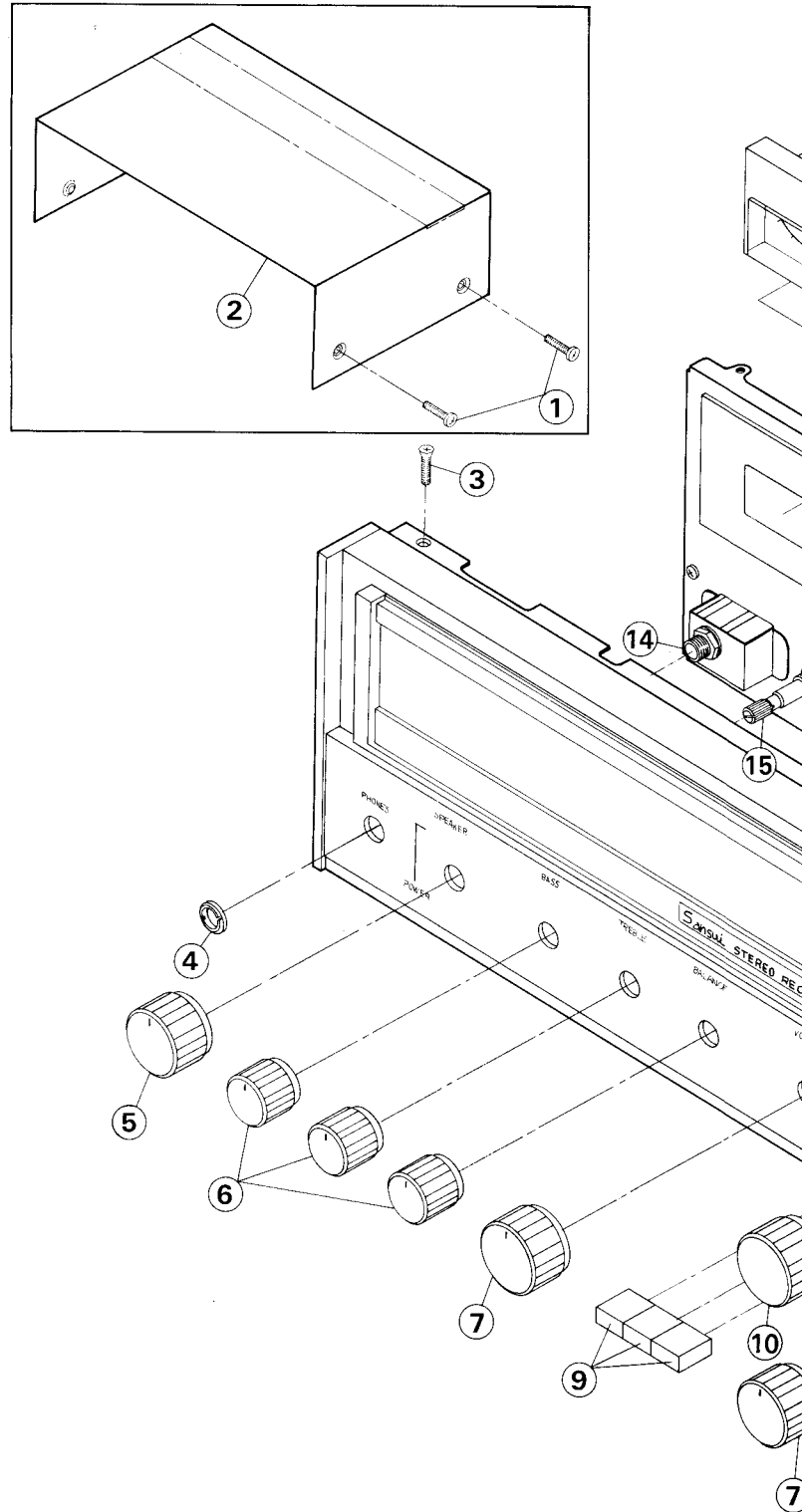

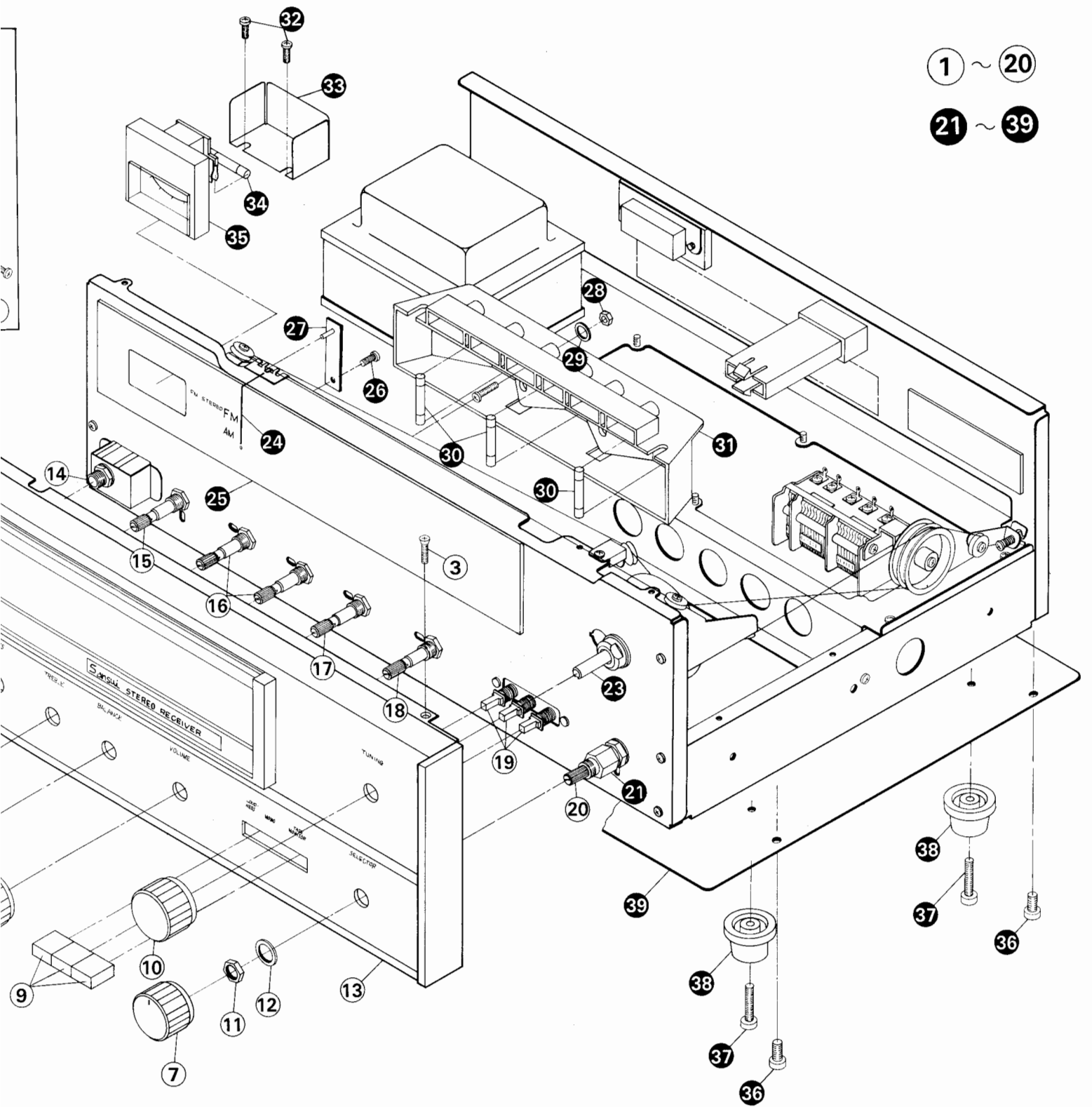

7. SCHEMATIC DIAGRAM

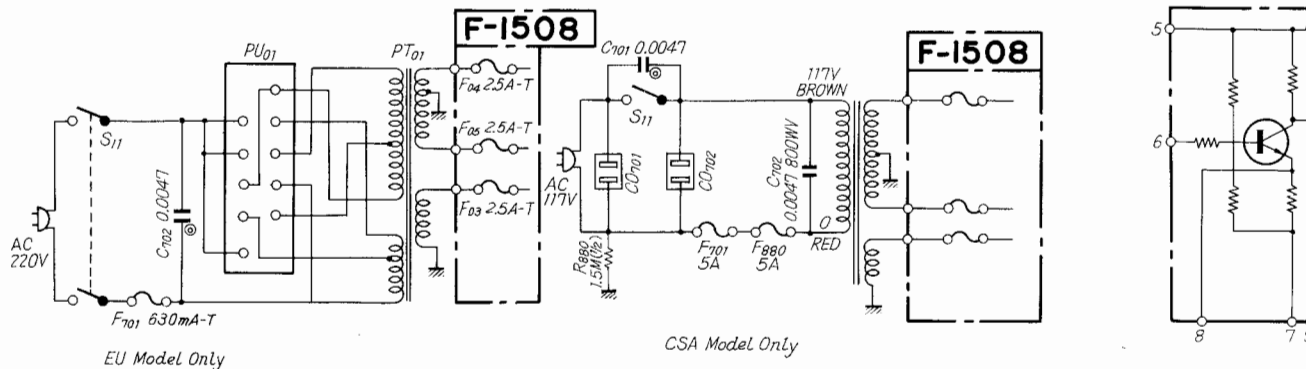
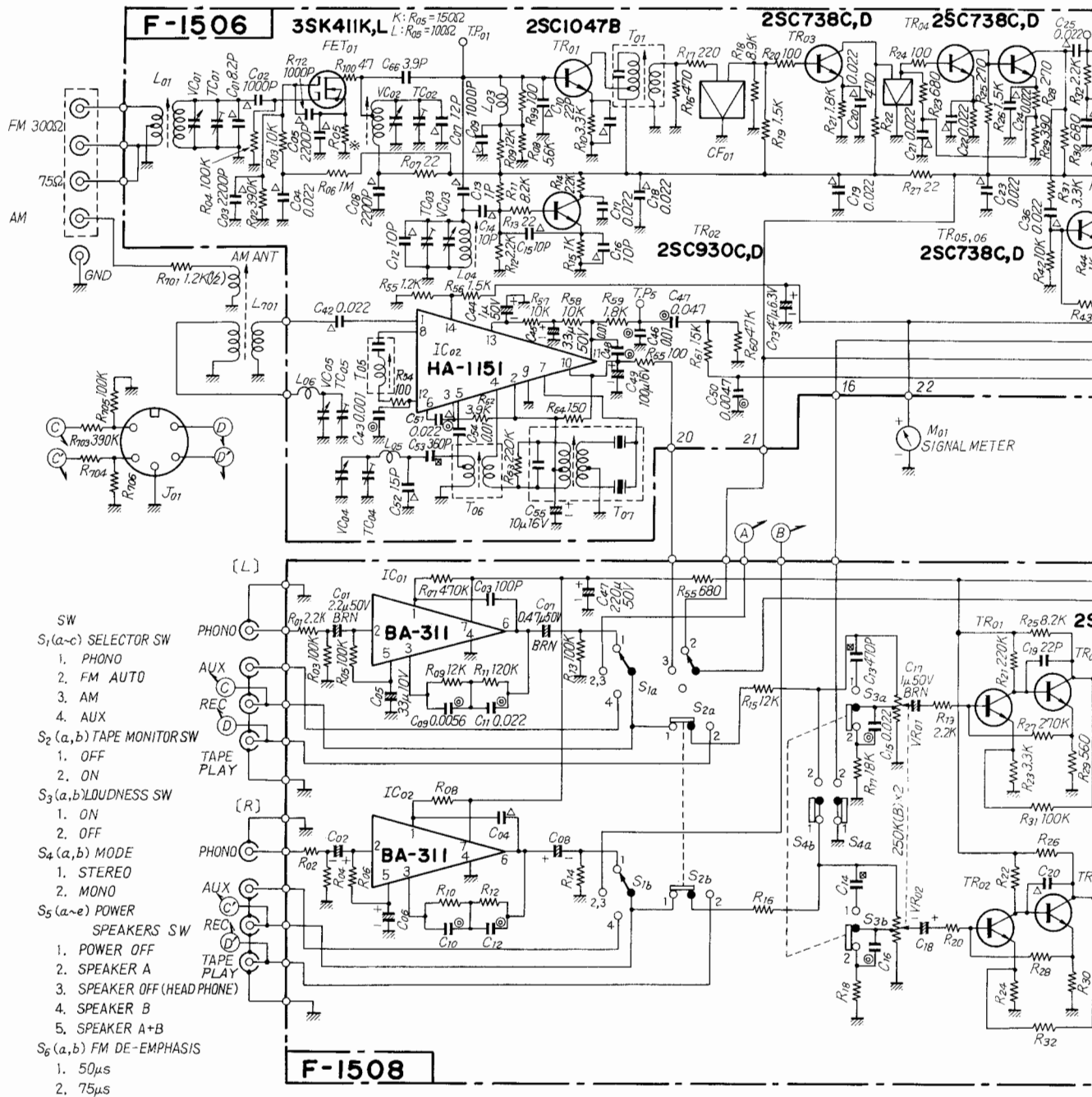

8. PACKING LIST

Parts No.	Stock No.	Description
1	9027780	Stylofoam Packing
2	9116152	Vinyl Cover
3	9007990	Carton Case

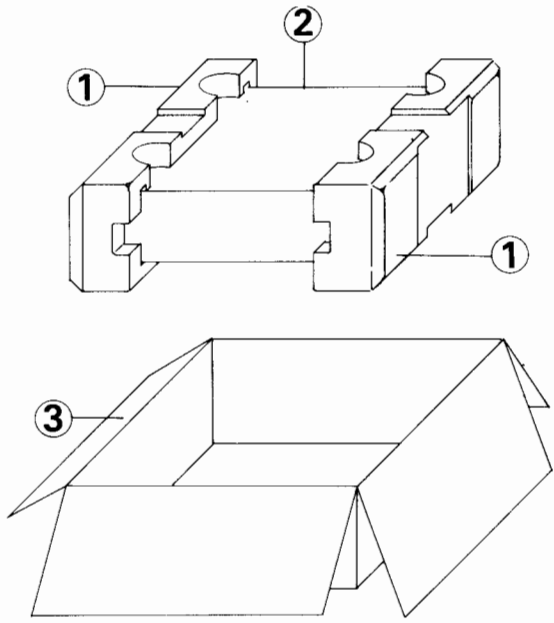

9. ACCESSORY PARTS LIST

Stock No.	Description
3820091	FM Antenna
0433610	2A Quick Acting Fuse
9208190	Operating Instructions
9228190	Operating Instruction Sheet



SANSUI ELECTRIC CO., LTD.
14-1, 2-chome, Izumi, Suginami-ku, Tokyo 168, Japan
TELEPHONE: (03) 323-1111/TELEX: 232-2076

SM019

Printed in Japan (84830M)

A vertical column of five semi-circular punch holes is located on the right edge of the page.