

# SERVICE MANUAL

DIGITAL SYNTHESIZER DC STEREO RECEIVER

## SANSUI 5900Z 4900Z 3900Z

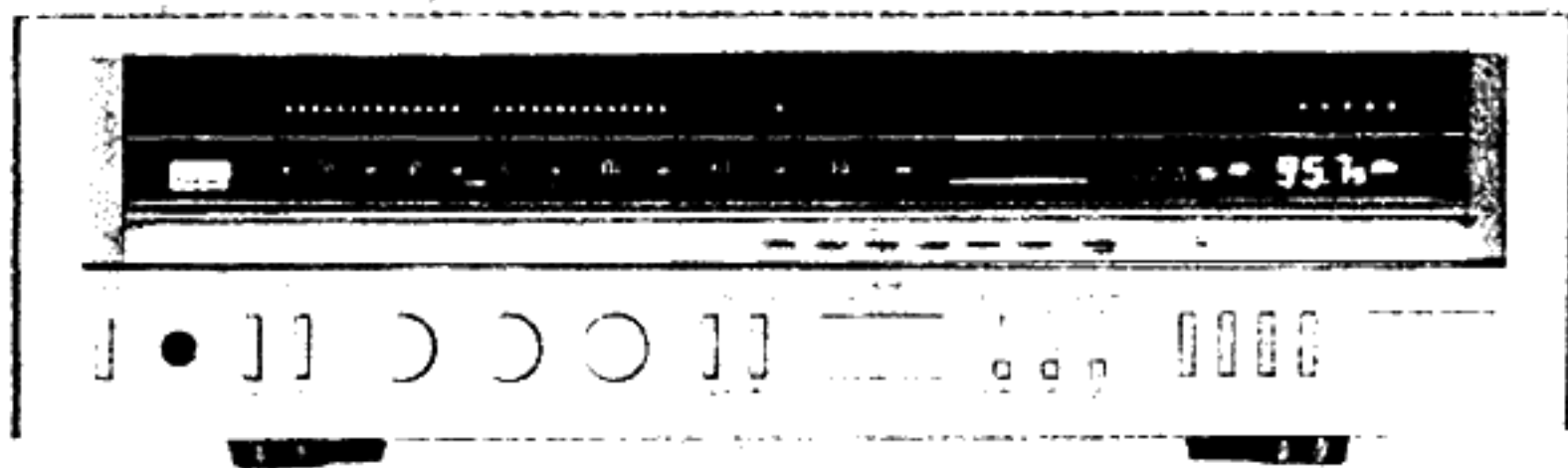

*Sansui*

SANSUI ELECTRIC CO., LTD.

### SPECIFICATIONS

<5900Z>

#### Audio section

##### Power output

Min. RMS, both channels driven, from 20 to 20,000 Hz, with no more than 0.03 % total harmonic distortion

75 watts per channel into 8 ohms

##### Load impedance

8 ohms

##### Total harmonic distortion

less than 0.03 % at or below

rated min. RMS power output

##### Intermodulation distortion (60 Hz - 7 kHz - 4:1 SMPTE method)

less than 0.03 % at rated

power output

##### Frequency response (at 1 watt)

Overall (from AUX) 5 to 100,000 Hz, +0 dB,

-3.0 dB

##### RIAA curve deviation (PHONO, 20 Hz to 20 kHz)

+0.3 dB, -0.3 dB

##### Damping factor (20 Hz to 20 kHz, both channels driven)

40 into 8 ohms

##### Input sensitivity and impedance (at 1 kHz)

PHONO 2.5 mV/47 kilohms

(Max. input capability: 180 mV at 1 kHz, less than 0.1 % total

harmonic distortion)

TAPE-1, 2 PLAY, AUX 150 mV/47 kilohms

##### Output level (at 1 kHz)

TAPE-1, 2 REC 150 mV into 47 kilohms

##### Signal to noise ratio (short-circuit, A-network)

PHONO 80 dB

AUX 95 dB

##### Channel separation (at 1 kHz)

PHONO 50 dB

AUX 60 dB

##### Controls

BASS  $\pm 10$  dB at 50 Hz

TREBLE  $\pm 10$  dB at 10 kHz

HIGH FILTER -3 dB at 5 kHz (6 dB/oct)

LOUDNESS (VOLUME -30 dB position)

+8 dB at 50 Hz

+6 dB at 10 kHz

AUDIO MUTING -20 dB

#### FM section

Tuning range 88 to 108 MHz

##### Usable sensitivity

Mono IHF 10.8 dBf (1.9  $\mu$ V)

Stereo IHF 21 dBf

##### 50 dB quieting sensitivity

Mono 15 dBf

Stereo 37 dBf

##### Signal to noise ratio (at 65 dBf)

Mono 76 dB

Stereo 70 dB

##### Distortion (at 65 dBf)

Mono less than 0.3 % at 100 Hz

less than 0.15 % at 1,000 Hz

less than 0.4 % at 6,000 Hz

less than 0.3 % at 100 Hz

less than 0.18 % at 1,000 Hz

less than 0.4 % at 6,000 Hz

##### Alternate channel selectivity (at 400 kHz)

60 dB

##### Capture ratio

1.0 dB

##### Image response ratio

50 dB

##### Spurious response ratio

70 dB

##### IF response ratio

90 dB

##### Stereo separation

30 dB at 100 Hz

40 dB at 1,000 Hz

28 dB at 10,000 Hz

##### Frequency response

30 to 15,000 Hz

+0.5 dB, -1.0 dB

##### Hum and noise (at 65 dBf)

70 dB

##### Antenna input impedance

300 ohms balanced

75 ohms unbalanced

#### AM section

Tuning range 530 to 1,600 kHz

##### Usable sensitivity (bar antenna)

53 dB/m

##### Selectivity ( $\pm 10$ kHz)

30 dB

##### Signal to noise ratio

43 dB

##### Distortion (at 30 % Modulation, 80 dB/m)

less than 0.5 %

##### Image response ratio

40 dB at 1,000 kHz

##### IF response ratio

35 dB at 1,000 kHz

#### Others

##### Power requirements

Power voltage 120, 220, 240 V

(50/60 Hz)

For U.S.A. & Canada 120 V (60 Hz)

Power consumption

Rated consumption 280 watts 360 VA

Maximum consumption 350 watts

##### Dimensions

485 mm (19-1/8") W

138 mm (5-7/16") H

313 mm (12-3/8") D

##### Weight

9.5 kg (20.9 lbs) net

10.7 kg (23.6 lbs) packed

**SPECIFICATIONS**

**<4900Z>**

**Audio section**

**Power output**  
Min. RMS, both channels driven, from 20 to 20,000 Hz, with no more than 0.03 % total harmonic distortion.  
55 watts per channel into 8 ohms

**Load impedance** . . . . . 8 ohms  
**Total harmonic distortion** . . . . . less than 0.03 % at or below rated min. RMS power output  
**Intermodulation distortion** (60 Hz : 7 kHz = 4:1 SMPTE method) . . . . . less than 0.03 % at rated power output

**Frequency response** (at 1 watt)  
Overall (from AUX) . . . . . 5 to 100,000 Hz, +0 dB, -3.0 dB

**RIAA curve deviation** (PHONO, 20 Hz to 20 kHz)  
. . . . . +0.3 dB, -0.3 dB

**Damping factor** (20 Hz to 20 kHz, both channels driven)  
40 into 8 ohms

**Input sensitivity and impedance** (at 1 kHz)  
PHONO . . . . . 2.5 mV/47 kilohms  
(Max. input capability: 180 mV at 1 kHz, less than 0.1 % total harmonic distortion)  
TAPE, AUX . . . . . 150 mV/47 kilohms

**Output level** (at 1 kHz)  
TAPE REC . . . . . 150 mV into 47 kilohms

**Signal to noise ratio** (short-circuit, A-network)

PHONO . . . . . 80 dB  
AUX . . . . . 95 dB

**Channel separation** (at 1 kHz)  
PHONO . . . . . 50 dB  
AUX . . . . . 60 dB

**Controls**

BASS . . . . . ± 10 dB at 50 Hz  
TREBLE . . . . . ± 10 dB at 10 kHz  
HIGH FILTER . . . . . -3 dB at 5 kHz (6 dB/oct)  
LOUDNESS (VOLUME -30 dB position)  
. . . . . +8 dB at 50 Hz  
. . . . . +6 dB at 10 kHz

**FM section**

**Tuning range** . . . . . 88 to 108 MHz  
**Usable sensitivity**  
Mono IHF . . . . . 10.8 dBf (1.9 µV)  
Stereo IHF . . . . . 21 dBf

**50 dB quieting sensitivity**  
Mono . . . . . 15 dBf  
Stereo . . . . . 37 dBf

**Signal to noise ratio** (at 65 dBf)  
Mono . . . . . 76 dB  
Stereo . . . . . 70 dB

**Distortion** (at 65 dBf)  
Mono . . . . . less than 0.3 % at 100 Hz  
less than 0.15 % at 1,000 Hz  
less than 0.4 % at 6,000 Hz  
Stereo . . . . . less than 0.3 % at 100 Hz  
less than 0.18 % at 1,000 Hz  
less than 0.4 % at 6,000 Hz

**Alternate channel selectivity** (at 400 kHz)  
. . . . . 60 dB  
**Capture ratio** . . . . . 1.0 dB  
**Image response ratio** . . . . . 50 dB  
**Spurious response ratio** . . . . . 70 dB  
**IF response ratio** . . . . . 90 dB

**Stereo separation** . . . . . 30 dB at 100 Hz  
40 dB at 1,000 Hz  
28 dB at 10,000 Hz  
**Frequency response** . . . . . 30 to 15,000 Hz  
+0.5 dB, -1.0 dB  
70 dB  
**Hum and noise** (at 65 dBf) . . . . . 70 dB  
**Antenna input impedance** . . . . . 300 ohms balanced  
75 ohms unbalanced

**AM section**

**Tuning range** . . . . . 530 to 1,600 kHz  
**Usable sensitivity** (bar antenna) . . . . . 53 dB/m  
**Selectivity** (± 10 kHz) . . . . . 30 dB  
**Signal to noise ratio** . . . . . 43 dB  
**Distortion** (at 30 % Modulation) . . . . . 80 dB/m  
less than 0.5 %  
**Image response ratio** . . . . . 40 dB at 1,000 kHz  
**IF response ratio** . . . . . 35 dB at 1,000 kHz

**Others**

**Power requirements**  
Power voltage . . . . . 120, 220, 240 V (50/60 Hz)  
For U.S.A. & Canada . . . . . 120 V (60 Hz)  
Power consumption  
Rated consumption . . . . . 200 watts 240 VA  
Maximum consumption . . . . . 250 watts  
**Dimensions** . . . . . 485 mm (19-1/8") W  
138 mm (5-7/16") H  
318 mm (12-9/16") D  
**Weight** . . . . . 8.5 kg (18.7 lbs) net  
9.7 kg (21.4 lbs) packed

**<3900Z>**

**Audio section**

**Power output**  
Min. RMS, both channels driven, from 30 to 20,000 Hz, with no more than 0.03 % total harmonic distortion.  
40 watts per channel into 8 ohms

**Load impedance** . . . . . 8 ohms  
**Total harmonic distortion** . . . . . less than 0.03 % at or below rated min. RMS power output  
**Intermodulation distortion** (60 Hz : 7 kHz = 4:1 SMPTE method) . . . . . less than 0.03 % at rated power output

**Frequency response** (at 1 watt)  
Overall (from AUX) . . . . . 5 to 100,000 Hz, +0 dB, -3.0 dB

**RIAA curve deviation** (PHONO, 20 Hz to 20 kHz)  
. . . . . +0.3 dB, -0.3 dB

**Damping factor** (30 Hz to 20 kHz, both channels driven)  
40 into 8 ohms

**Input sensitivity and impedance** (at 1 kHz)  
PHONO . . . . . 2.5 mV/47 kilohms  
(Max. input capability: 180 mV at 1 kHz, less than 0.1 % total harmonic distortion)  
TAPE, AUX . . . . . 150 mV/47 kilohms

**Output level** (at 1 kHz)  
TAPE REC . . . . . 150 mV into 47 kilohms

**Signal to noise ratio** (short-circuit, A-network)  
PHONO . . . . . 73 dB  
AUX . . . . . 92 dB

**Channel separation** (at 1 kHz)  
PHONO . . . . . 50 dB  
AUX . . . . . 60 dB

**Controls**

BASS . . . . . ± 10 dB at 50 Hz  
TREBLE . . . . . ± 10 dB at 10 kHz  
HIGH FILTER . . . . . -3 dB at 5 kHz (6 dB/oct)  
LOUDNESS (VOLUME -30 dB position)  
. . . . . +8 dB at 50 Hz  
. . . . . +6 dB at 10 kHz

**FM section**

**Tuning range** . . . . . 88 to 108 MHz  
**Usable sensitivity**  
Mono IHF . . . . . 10.8 dBf (1.9 µV)  
Stereo IHF . . . . . 21 dBf

**50 dB quieting sensitivity**  
Mono . . . . . 15 dBf  
Stereo . . . . . 37 dBf

**Signal to noise ratio** (at 65 dBf)  
Mono . . . . . 76 dB  
Stereo . . . . . 70 dB

**Distortion** (at 65 dBf)  
Mono . . . . . less than 0.3 % at 100 Hz  
less than 0.15 % at 1,000 Hz  
less than 0.4 % at 6,000 Hz  
Stereo . . . . . less than 0.3 % at 100 Hz  
less than 0.18 % at 1,000 Hz  
less than 0.4 % at 6,000 Hz

**Alternate channel selectivity** (at 400 kHz)  
. . . . . 60 dB

**Capture ratio** . . . . . 1.0 dB  
**Image response ratio** . . . . . 50 dB  
**Spurious response ratio** . . . . . 70 dB  
**IF response ratio** . . . . . 90 dB

**Stereo separation** . . . . . 30 dB at 100 Hz  
40 dB at 1,000 Hz  
28 dB at 10,000 Hz  
**Frequency response** . . . . . 30 to 15,000 Hz  
+0.5 dB, -1.0 dB  
70 dB  
**Hum and noise** (at 65 dBf) . . . . . 70 dB  
**Antenna input impedance** . . . . . 300 ohms balanced  
75 ohms unbalanced

**AM section**

**Tuning range** . . . . . 530 to 1,600 kHz  
**Usable sensitivity** (bar antenna) . . . . . 53 dB/m  
**Selectivity** (± 10 kHz) . . . . . 30 dB  
**Signal to noise ratio** . . . . . 43 dB  
**Distortion** (at 30 % Modulation) . . . . . 80 dB/m  
less than 0.5 %  
**Image response ratio** . . . . . 40 dB at 1,000 kHz  
**IF response ratio** . . . . . 35 dB at 1,000 kHz

**Others**

**Power requirements**  
Power voltage . . . . . 120, 220, 240 V (50/60 Hz)  
For U.S.A. & Canada . . . . . 120 V (60 Hz)  
Power consumption  
Rated consumption . . . . . 150 watts 190 VA  
Maximum consumption . . . . . 200 watts  
**Dimensions** . . . . . 485 mm (19-1/8") W  
138 mm (5-7/16") H  
318 mm (12-9/16") D  
**Weight** . . . . . 8.1 kg (17.7 lbs) net  
9.3 kg (20.5 lbs) packed

- \* Design and specifications subject to change without notice for improvements.
- \* In order to simplify the explanation illustrations may sometimes differ from the originals.

**1. BLOCK DIAGRAM**

**1-1. 5900Z Audio Section**

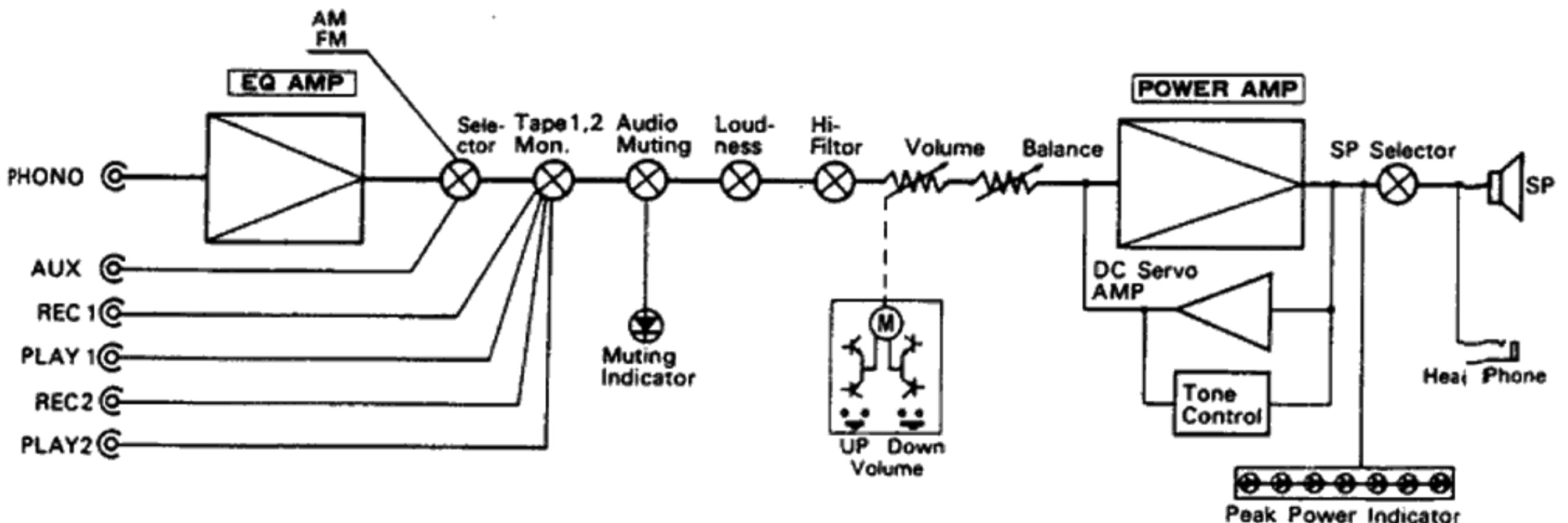

1-2. 4900Z, 3900Z Audio Section

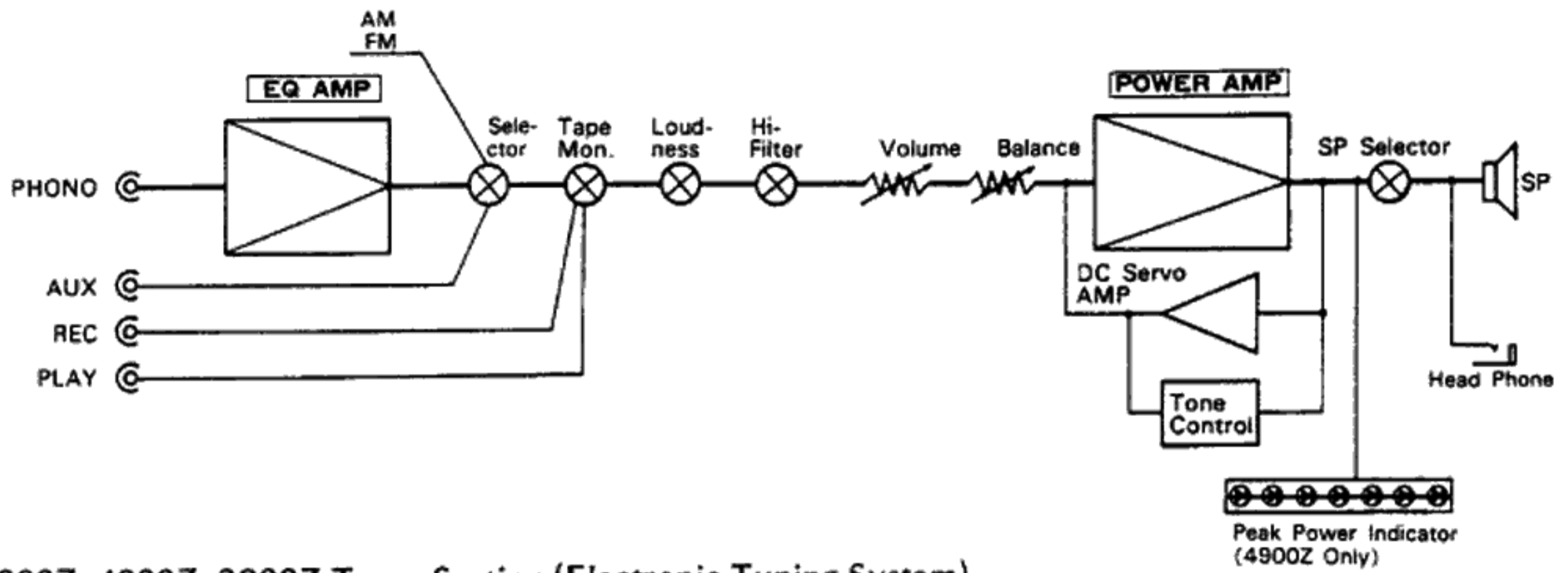

1-3. 5900Z, 4900Z, 3900Z Tuner Section (Electronic Tuning System)

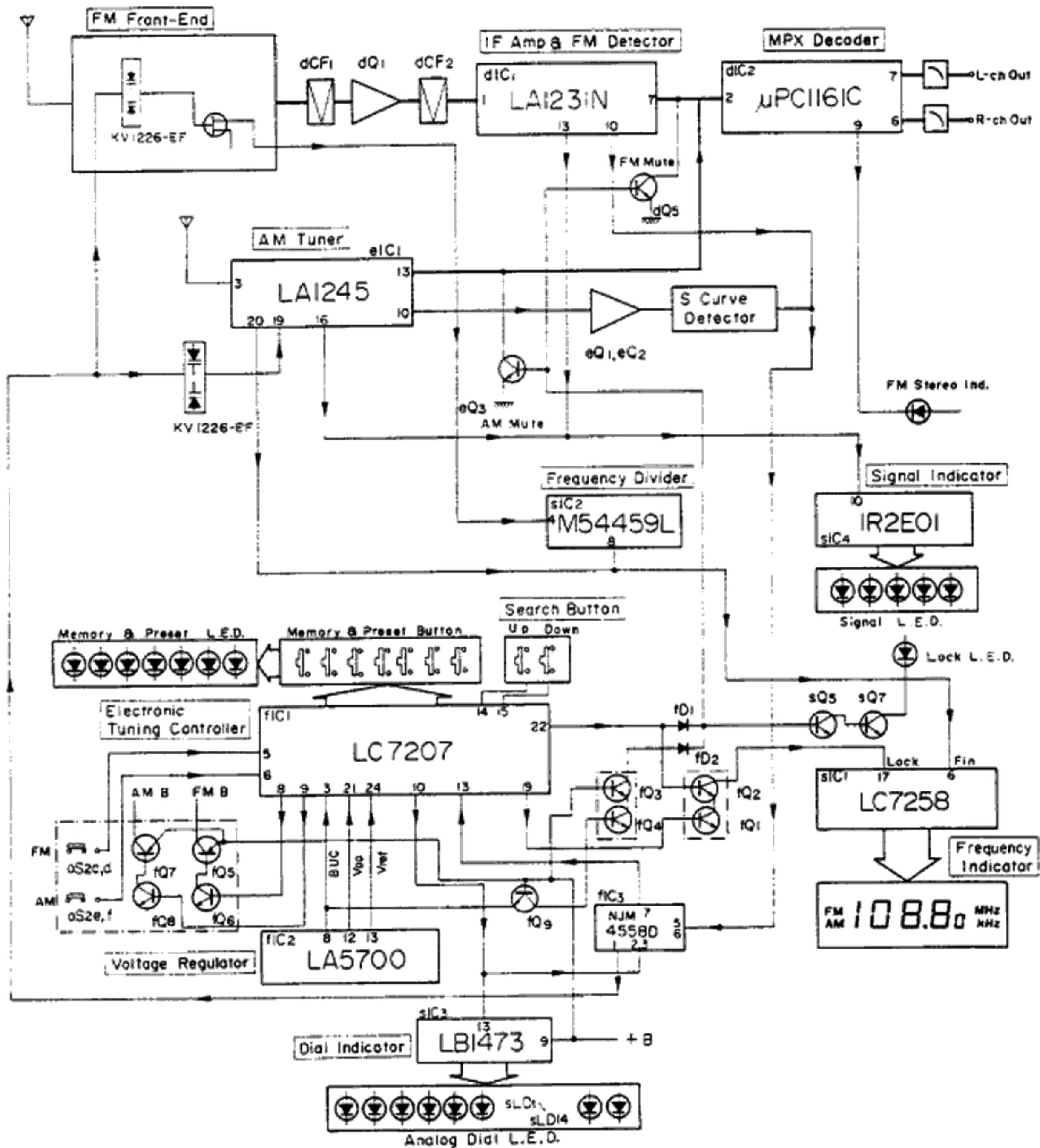

## 2. OPERATION

### 2-1. General

#### 1) Band Select Operation

By depressing the AM (oS<sub>2e</sub>, f) or FM (oS<sub>2c</sub>, d) mode selector switch, +B is supplied to fIC<sub>2</sub> voltage regulator and Pin No. 6 (fIC<sub>1</sub>) for AM or Pin No. 5 for FM, and regulated power supply is fed to fIC<sub>1</sub> electronic tuning controller.

#### 2) Search Tuning Operation

When UP (fS<sub>9</sub>) or DOWN (fS<sub>8</sub>) search button is depressed, Pin No. 14 (fIC<sub>1</sub>) or Pin No. 15 (fIC<sub>1</sub>) is grounded. Then automatic search circuit starts for Upper or Lower frequency, and tuning voltage (voltage of variable capacitance diode) from Pin No. 10 (fIC<sub>1</sub>) increases for UP or decreases for DOWN.

When a radio station signal came into the receiver and S-curve voltage from Pin No. 10 (dIC<sub>1</sub>) on FM or AM S-curve detector on AM is fed to Pin No. 13 (fIC<sub>1</sub>) via fIC<sub>3</sub>, the radio station is tuned as procedure of Fig. 2-1.

In case of UP or DOWN button is kept depressed, the automatic search circuit continues its operation even when any radio station signal came into the receiver.

#### 3) Preset Tuning Operation

One of the preset channel buttons, i.e. channel (1) is depressed. Pin No. 41 (fIC<sub>1</sub>) and sLD<sub>23</sub> are grounded and kept shorting to ground by fIC<sub>1</sub>.

Digital signal of the radio station memorized on channel (1) comes out from 10 pins from Pin No. 25 to Pin No. 34, and converted to analog voltage and fed to Pin No. 11 (fIC<sub>1</sub>). fIC<sub>1</sub> starts Fetch action and tunes the radio station memorized on channel (1) as procedure of Fig. 2-2.

#### 4) Preset Memory Operation

During the unit is receiving a radio station either AM or FM, the digital signal converted from the tuning voltage appears on 10 pins from Pin No. 25 to Pin No. 34 (fIC<sub>1</sub>). On this position, one of the preset channel buttons is depressed when the memory button is kept depressed, the digital signal is memorized with tuning band mode on the depressed preset channel. (Previous preset station is erased when this preset memory is operated.)

### 2-2. Priority of Functions

#### 1) Tuning Function

- 1st . . . . . UP search tuning
- 2nd . . . . . DOWN search tuning
- 3rd . . . . . Preset tuning

#### 2) Band Selector

- 1st . . . . . FM
- 2nd . . . . . AM

#### 3) Preset Channel

First depressed channel has priority.

### 2-3. Automatic Tuning Compensation Operation.

#### 1) Fetch Action (Refer to Fig. 2-2)

On the preset tuning, when the S-curve is out of detection by tuner drift, the tuning voltage swings up to  $\pm 8$  steps (about  $\pm 56$  mV) as preset voltage center. But in case of no S-curve detection caused weak station signal, the tuning voltage returns to first preset voltage after Fetch action.

#### 2) AFC Operation (Refer to Fig. 2-1 and Fig. 2-2)

On the automatic search and the preset tuning, the S-curve voltage fed to Pin No. 13 (fIC<sub>1</sub>) to control 10 bit up/down counter through window comparator. The output of the counter is converted to analog voltage by external ladder resistor and fed to Pin No. 11 (fIC<sub>1</sub>) and controls the tuning voltage for optimum reception.

On the other hand, PWM (Pulse Width Modulation) signal from Pin No. 23 (fIC<sub>1</sub>) is also converted to analog voltage and added to above analog voltage for exact tuning.

### 2-4. Other Operations

#### 1) Muting Operation

Pin No. 22 (fIC<sub>1</sub>) holds H level (about +8 V) during the automatic search tuning, the preset tuning and the band select operations. This H level is fed to Base terminals of dQ<sub>5</sub> and eQ<sub>3</sub> (F-3318), and both AM and FM audio signals are grounded through transistors.

#### 2) Back Up Control Operation

When the mode selector is not AM or FM mode, or Power switch is OFF, previous tuner reception frequency must be memorized. For this memorization, Back Up Control Circuit applies to BUC terminal Pin No. 3 (fIC<sub>1</sub>).

The back up control circuit is controlled by output voltage of Pin No. 8 (fIC<sub>2</sub>) which is connected to Emitter terminal of fQ<sub>9</sub> (F-3326).

The output voltage of Pin No. 8 turns off faster than tuner B voltage which is connected to Base terminal of fQ<sub>9</sub> when the mode selector is switched from AM or FM mode to another mode, or the Power is switched off. This means Collector terminal of fQ<sub>9</sub> turns to L level before the tuner B turns off. Then the back up circuit is actuated, and the tuner reception frequency is memorized in the fIC<sub>1</sub>.

Fig.2-1 Search Tuning

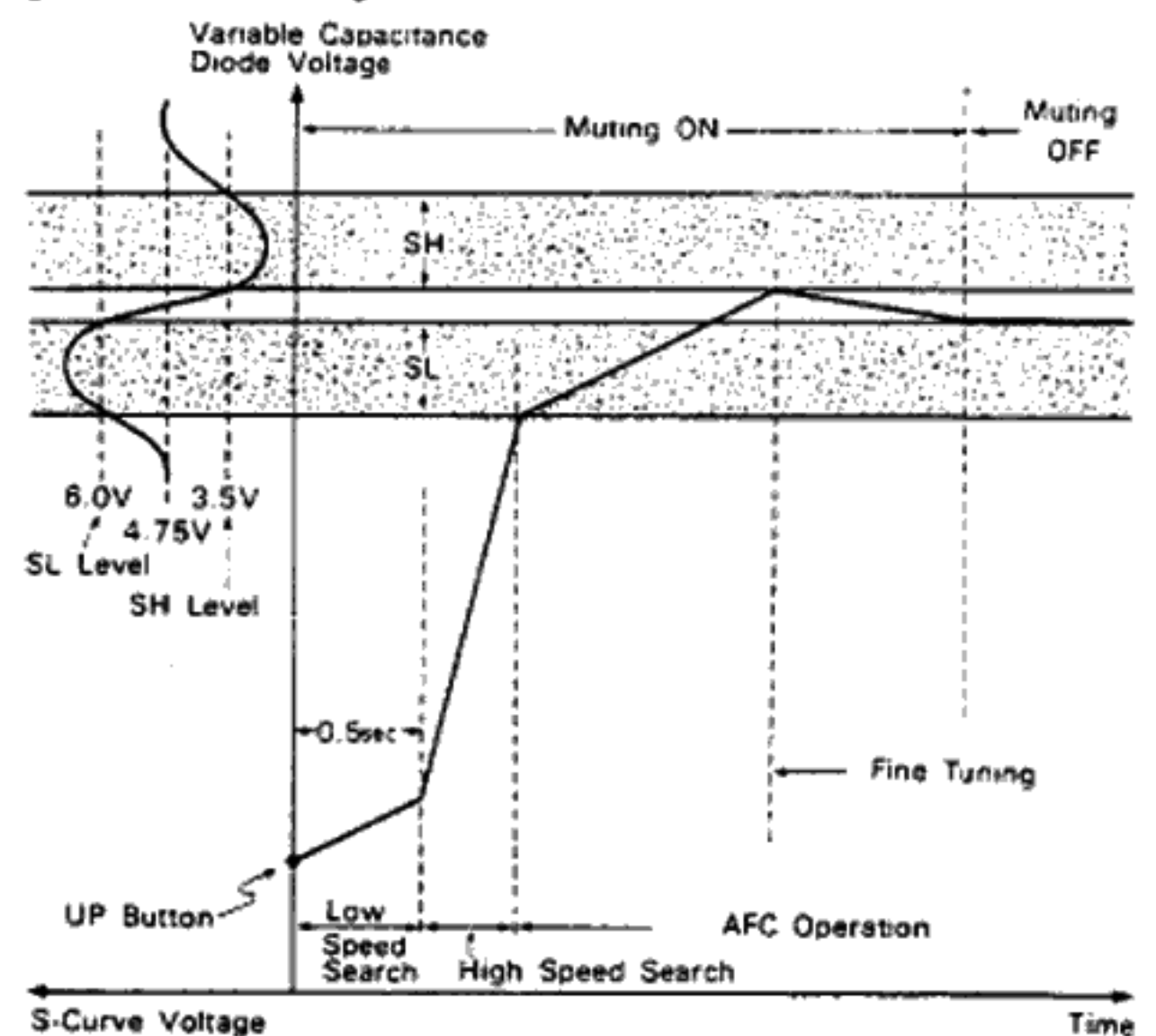
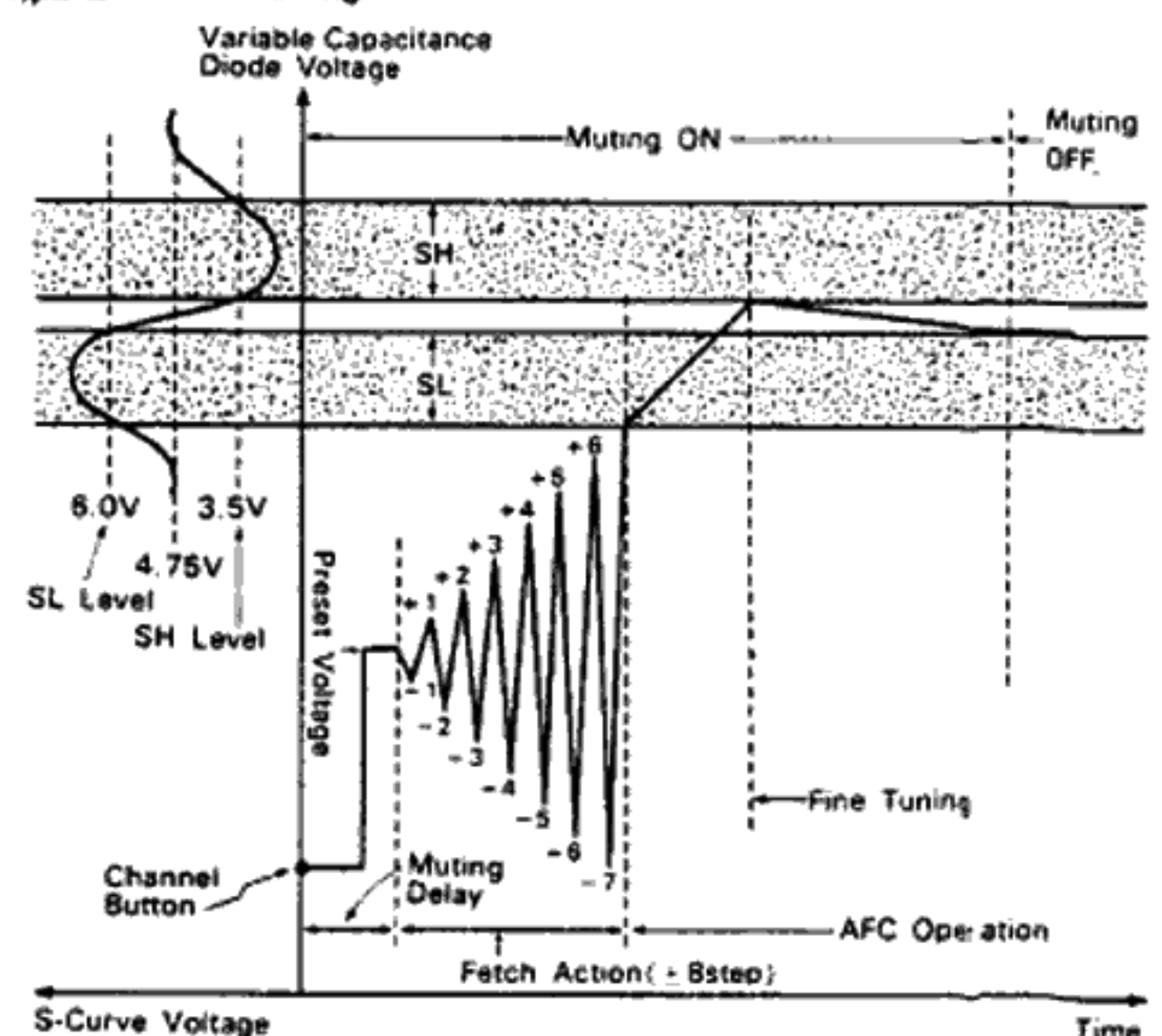

Fig.2-2 Preset Tuning



Pin No.	Pin Name	Input/Output	Description of Function and Operation
14	UP	Input	Automatic search input pin At L level, UP search starts and continues its operation until S-curve voltage is fed to S-Curve input pin and AFC operation is completed.
15	DOWN	Input	Automatic search input pin At L level, DOWN search starts and continues its operation until S-curve voltage is fed to S-Curve input pin and AFC operation is completed.
16	MANU	Input	Manual tuning select pin At L level, manual tuning function is selected. When UP or DOWN input pin is turned to L level, manual tuning function is released.
17	MEMO	Input	Preset memory function input pin During L level is held, memory operation is available.
18	M-U/D	Input	Output voltage of external comparator which composes analog/digital converter is fed to this input pin. At H level, 10 bit data counts up and output voltage of external ladder resistor increases. At L level, 10 bit data counts down and output voltage of external ladder resistor decreases.
19	DX-LO	Output	Tuner sensitivity control pin When automatic search tuning is in operation, pin voltage holds L level. Normally H level.

Pin No.	Pin Name	Input/Output	Description of Function and Operation
20	M-IND	Output	Indicator signal output pin of manual tuning When manual tuning function is selected, output turns to L level.
21	VDD		Power supply is connected to this pin. +9 V typ: Normal operation +5 V typ: Back up operation
22	MUTE	Output	Muting control signal output pin H level is held when automatic search tuning, preset tuning or band selection is in operation.
23	F-Tune	Output	Output pin for fine tuning AFC voltage is generated by connecting external low-pass filter.
24	Vref		Reference voltage (+8 V typ) is supplied for internal digital/analog converter and reference comparator level window comparator.
25 ~ 34	B1 ~ B10	Output	Output pins of 10 bit UP/DOWN counter (incl. buffer for ladder resistor) The outputs are converted from digital to analog voltage by external ladder resistor (R = more than 10 kΩ)
35	VSS		Ground pin of LSI
36 ~ 42	CH1 ~ CH7	Input/Output	Memory channel input and selected channel indicator output pins At L level, memorized station is tuned, and when MEMO pin is L level, a tuned station is memorized.

3-2.  $\mu$ PC1161C (MPX IC)

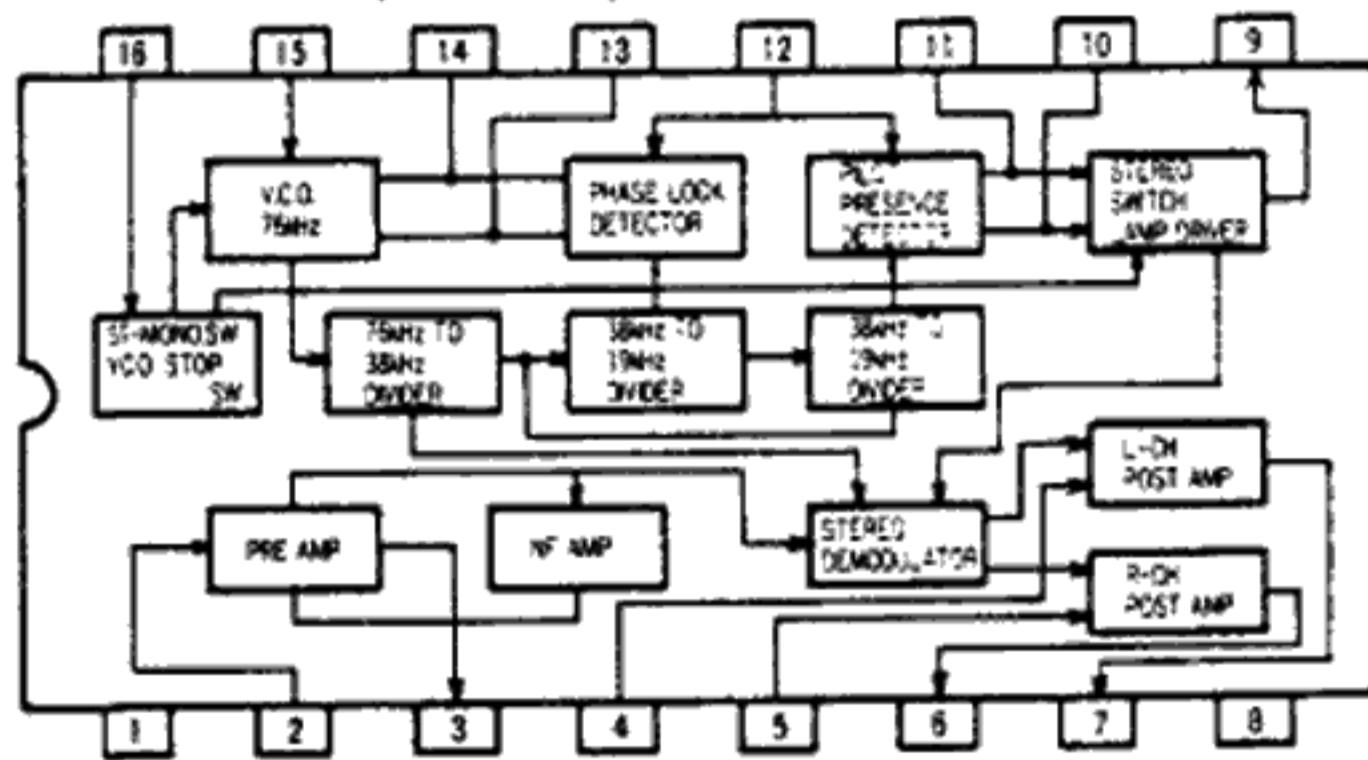

3-3. LA-1231N (IF amp. and FM detector IC)

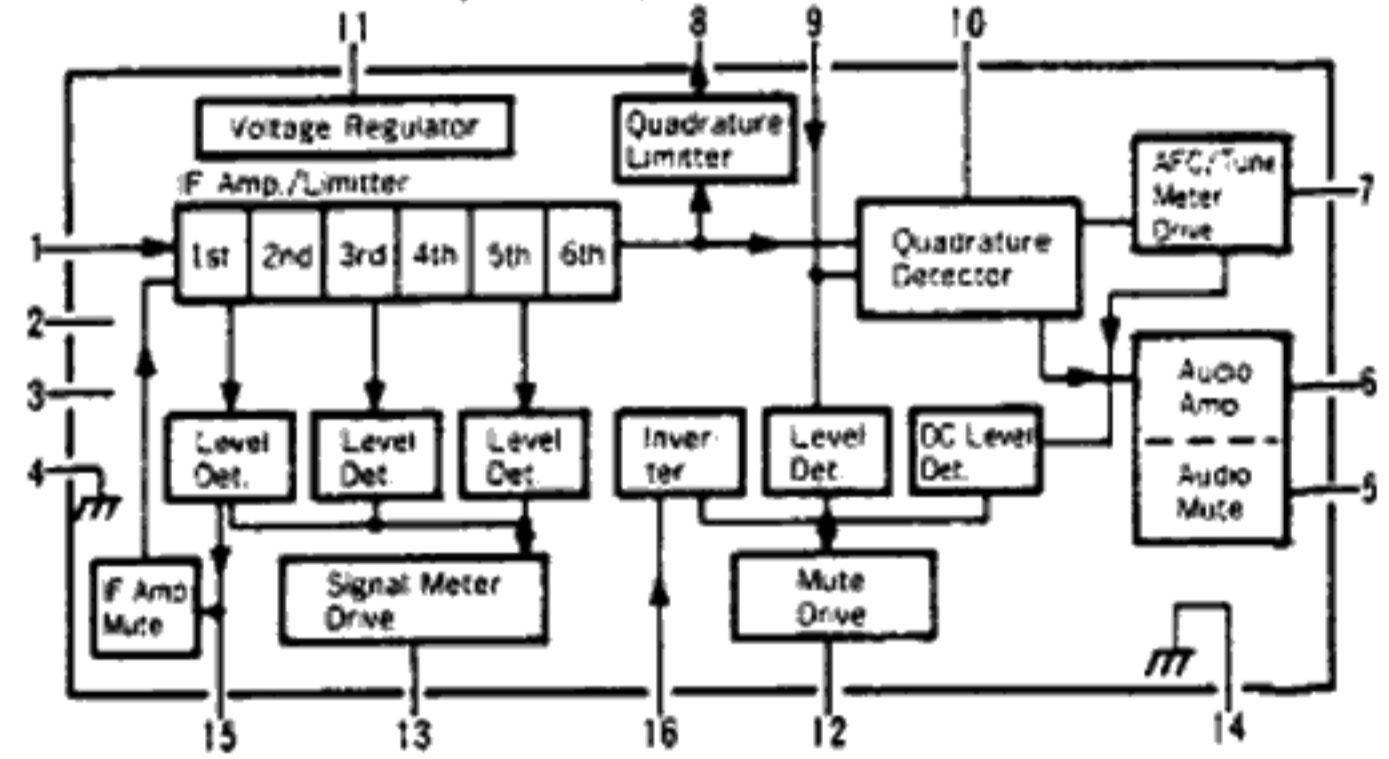

3-4. LA-1245 (AM Tuner IC)

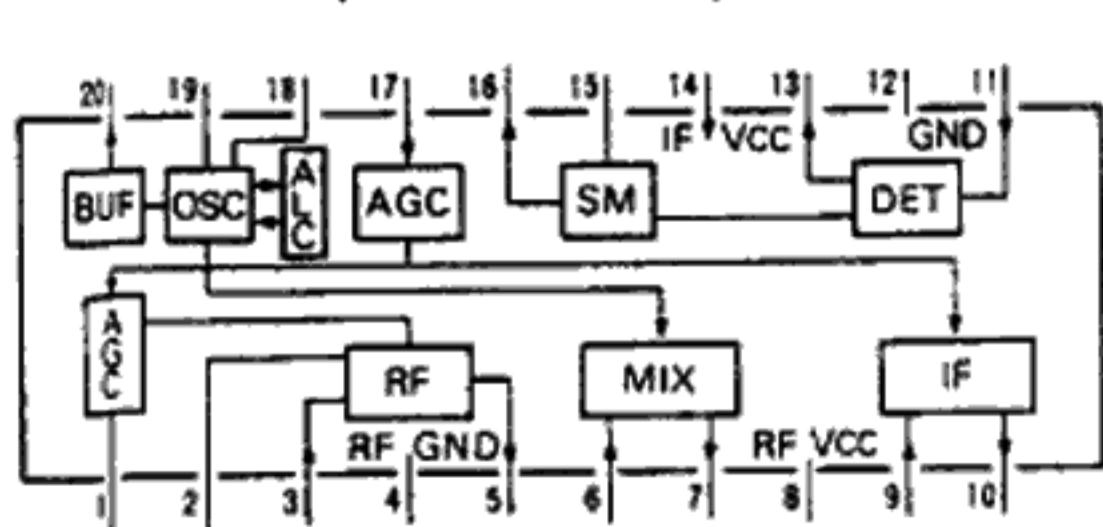

3-5. 1R2E01 (Signal Indicator IC)

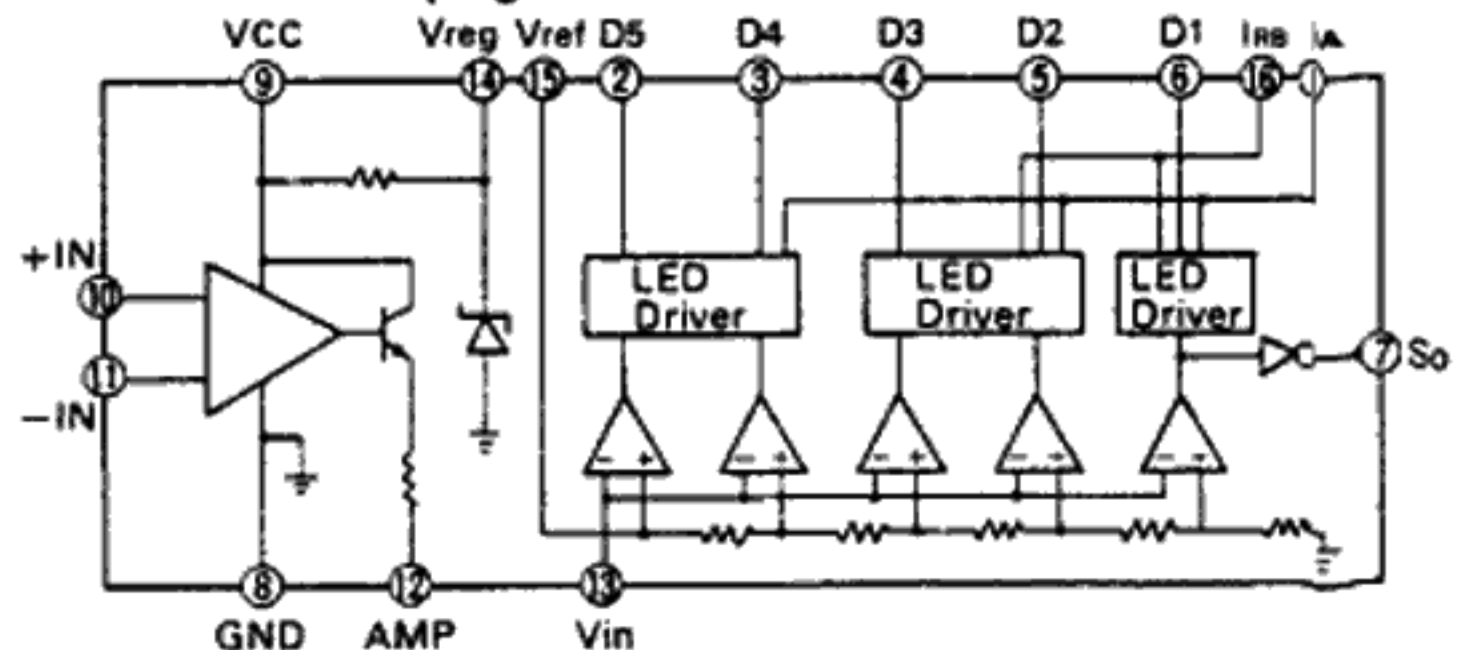

### 3. INTERIOR BLOCK DIAGRAM OF IC

#### 3-1. LC7207 (FM AM Electronic Tuning Controller IC)

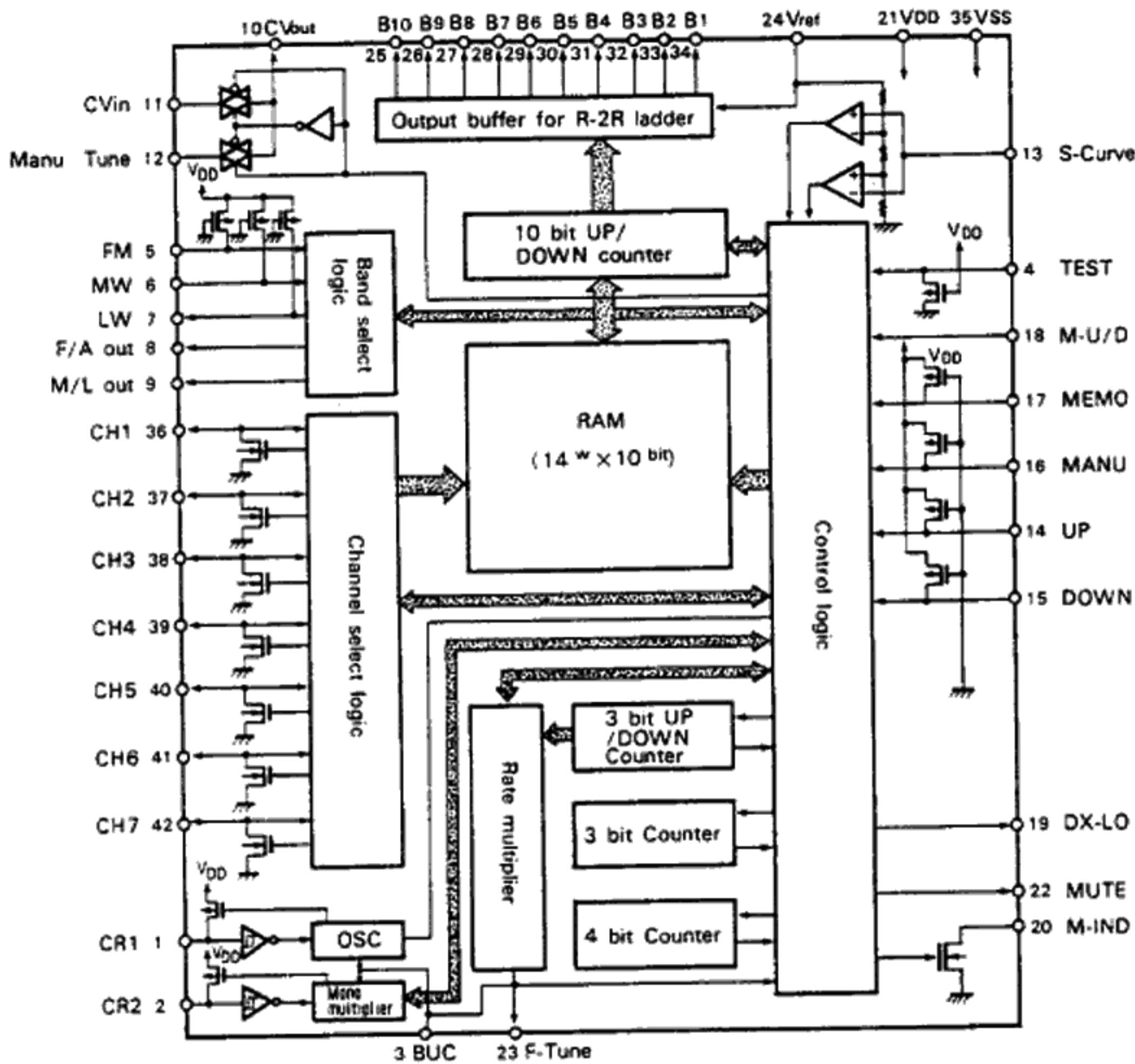

Table 3-1 Function and Operation of Each Pin

Pin No.	Pin Name	Input/Output	Description of Function and Operation
1	CR1	Input/Output	To this pin, C and R are connected for a clock pulse generator.
2	CR2	Input/Output	To this pin, C and R are connected for a timer to control a pulse width of MUTE pin output signal when the band selector is tuned.
3	BUC	Input	Memory back up function is operated by this input pin. At H level, the function is not actuated. At L level, the function is actuated.
4	TEST	Input	Test mode control pin for internal LSI circuit. At H level, LSI is normal operation mode. At L level, LSI is fixed to test mode.
5	FM	Input	FM band select pin. At H level, no band selection is made. At L level, FM band is selected.
6	MW	Input	MW band select pin. At H level, no band selection is made. At L level, MW band is selected.

Pin No.	Pin Name	Input/Output	Description of Function and Operation
7	LW	Input	LW band select pin. At H level, no band selection is made. At L level, LW band is selected.
8	F/A OUT	Output	Indicator control signal output pin. H level: FM band. L level: AM band.
9	M/L OUT	Output	Indicator control signal output pin. H level: MW band. L level: LW band.
10	CV OUT	Output	Voltage for variable capacitance diode from internal analog signal transfer gate comes out to this output pin.
11	CV IN	Input	This pin is an input of analog signal transfer gate, and obtains output voltage of external ladder resistor.
12	Manu Tune	Input	This pin is an input of analog signal transfer gate, and obtains output tuning voltage from manual tuning volume.
13	S-Curve	Input	S-curve voltage from AM or FM is fed to this input pin, and internal window comparator generates voltage required from AFC circuit.

STEP	SUBJECT	FEED SIGNAL		MEASURE OUTPUT	ADJUST	ADJUST FOR	REMARKS
		FROM	TO				
2.	Analog Dial Adj.	DC 1.20 V	Terminal No. 9 (F-3324)	Frequency Dial LED	sVR3 (F-3324)	Lighting point of 1st LED	Before adjustment, make 2nd LED from left end turn on
3.	AFC Center Voltage Adj.	No Input		Terminal No. 74 (F-3326) DC Volt Meter	dVR5 (F-3318)	4.75 V ±0.3 V	
4.	Discriminator Coil Adj.	No Input		Between TP2 & TP5 (F-3318) DC Volt Meter	Primary Coil of dT1 (F-3318)	DC 0 V	During adjustment, TP3 must be grounded (F-3318)
5.	Discriminator Adj.	No Input		Between TP1 & TP5 (F-3318) DC Volt Meter	dVR4 (F-3318)	DC 0 V	Same as above
6.	Discriminator Coil Adj.	98 MHz ANT Input 65 dBf (59.8 dB) 1 kHz (100% MOD.) FM SSG	ANT Terminal 300Ω	REC OUT L-CH or R-CH Dist. Meter	Secondary Coil of dT1 (F-3318)	Min. THD	
7.	IF Coil Adj.	Same as above	Same as above	REC OUT L-CH or R-CH Dist. Meter	T2 (Front-end)	Min. THD	
8.	Muting Level Adj.	98 MHz ANT Input 11 dBf (5.8 dB) 1 kHz (100% MOD.) FM SSG	ANT Terminal 300Ω	Pin No. 12 of dIC1 (F-3318) DC Volt Meter	dVR1 (F-3318)	0.7 V	

(2) FM STEREO Adjustment

Note: FM Mode ..... AUTO

STEP	SUBJECT	FEED SIGNAL		MEASURE OUTPUT	ADJUST	ADJUST FOR	REMARKS
		FROM	TO				
1.	PLL VCO Adj.	98 MHz ANT Input 65 dBf (59.8 dB) FM SSG Pilot 19 kHz (9% MOD.) SUB 1 kHz + Pilot (100% MOD) STEREO SG	ANT terminal 300Ω	Stereo indicator	dVR2 F-3318	Light indicator	Adjust the dVR 2 within center of lighting level.
	PLL VCO Adj. In case of using Freq. counter.	98 MHz ANT Input 65 dBf (59.8 dB) FM SSG (No MOD.)	Same as above	TP6 F-3318 Use Freq. counter	dVR2 F-3318	19 kHz ±40 Hz	
2.	FM STEREO Separation Adj.	98 MHz ANT Input 65 dBf (59.8 dB) FM SSG Pilot 19 kHz (9% MOD.) L MODE 1 kHz + Pilot (100% MOD.) Stereo SG	ANT Terminal 300Ω	REC OUT R-CH VTVM & Scope	dVR3 (F-3318)	Min. Output	Confirm R →L-CH

4-2. AM Adjustment

(1) AM RF, VOLTAGE SYNTHESIZER Adjustment

Note: 1. Selector ..... AM  
2. FM Mode ..... MONO

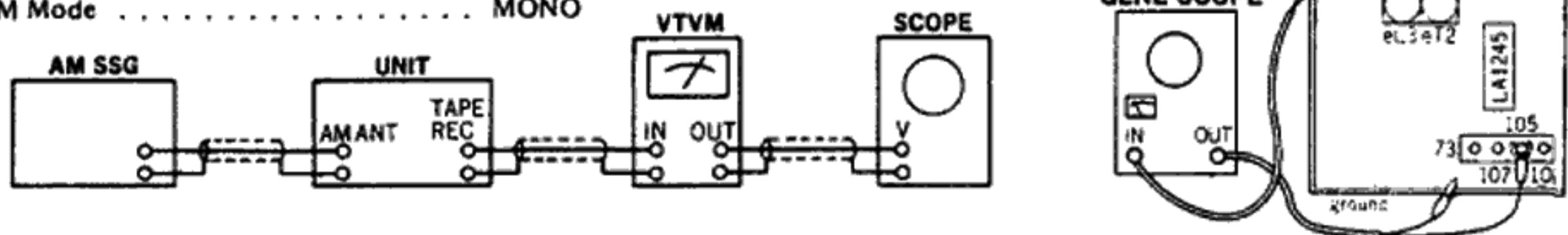

STEP	SUBJECT	FEED SIGNAL		MEASURE OUTPUT	ADJUST	ADJUST FOR	REMARKS
		FROM	TO				
1.	Counter OFF-SET Adj.	1455 kHz No MOD. AM SSG	Input Terminal No. 59 (F-3321)	Frequency Display Indication	sVR1 (F-3321)	1000 kHz	

### 3-6. LC7258 (5 Digit Frequency Indicator IC)

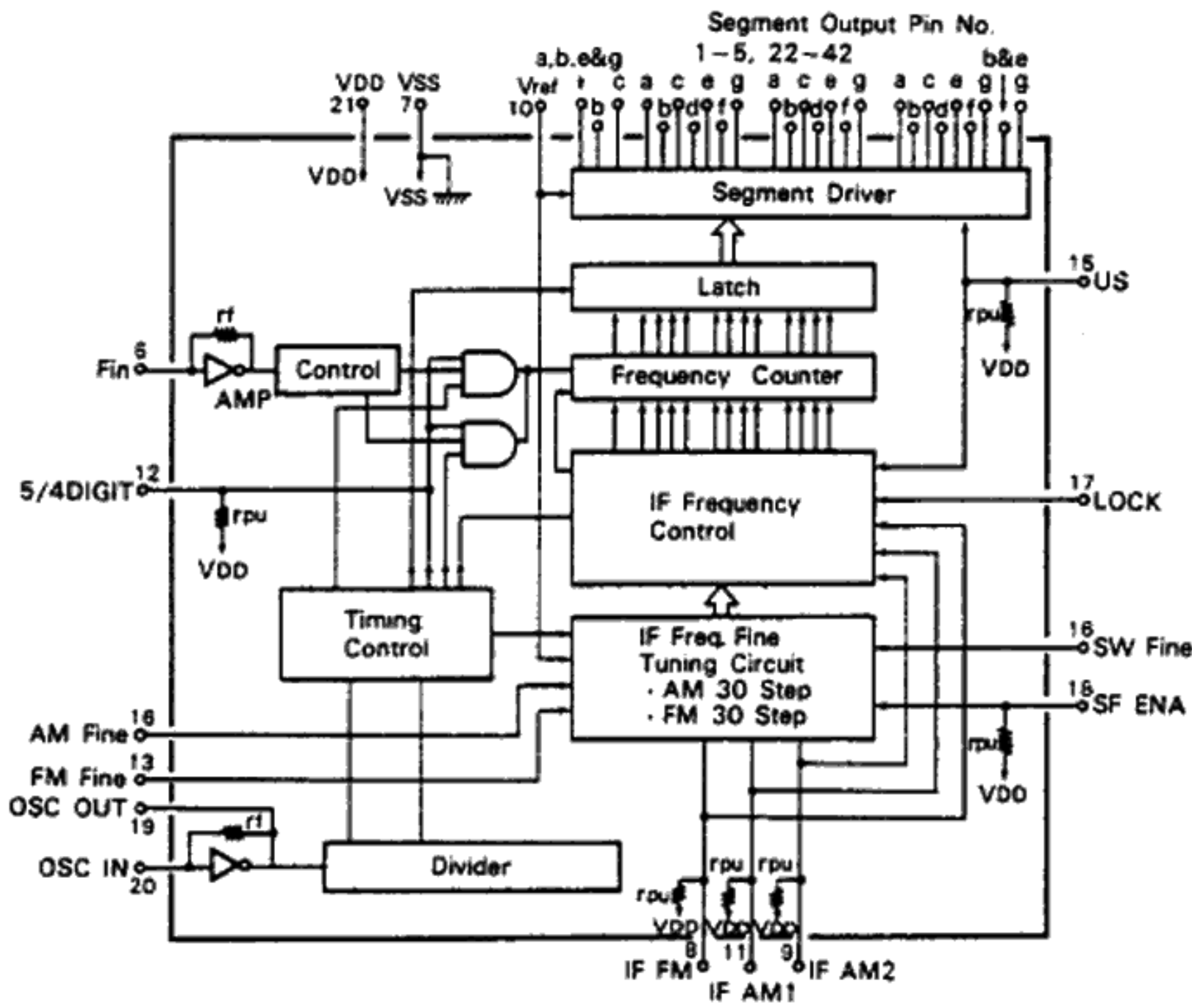

### 3-7. NJM4558D (OP Amp. IC)

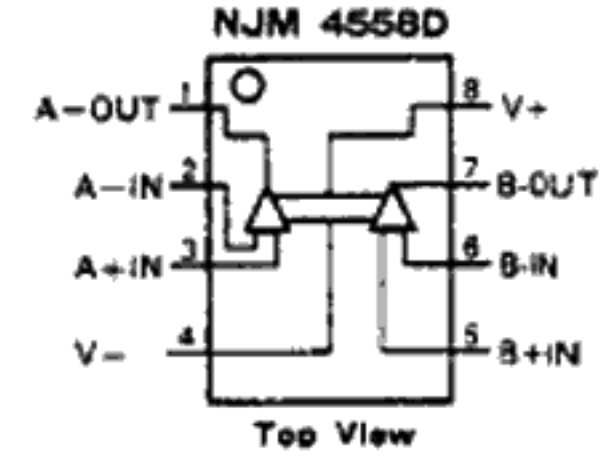

### 3-8. M54459L (Frequency Divider IC)

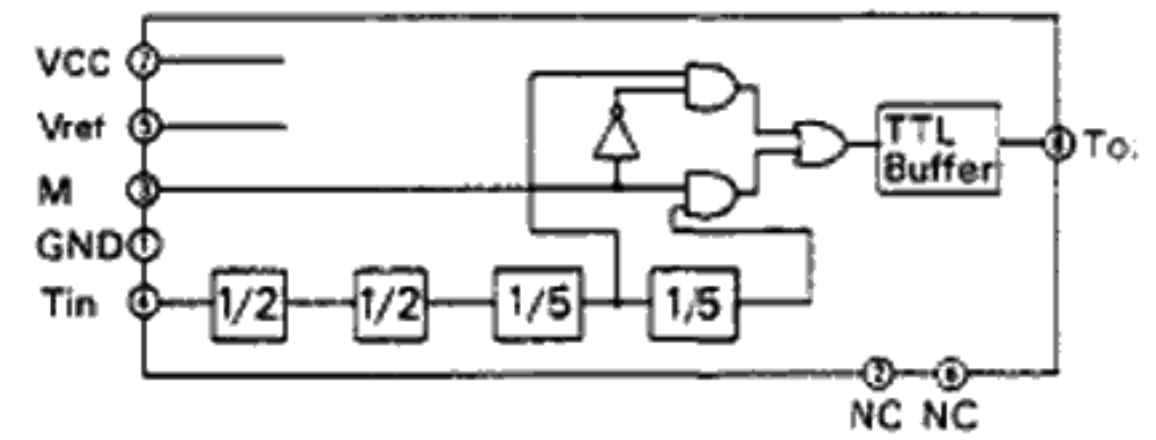

### 3-9. LB1473 (Analog Dial Indicator IC)

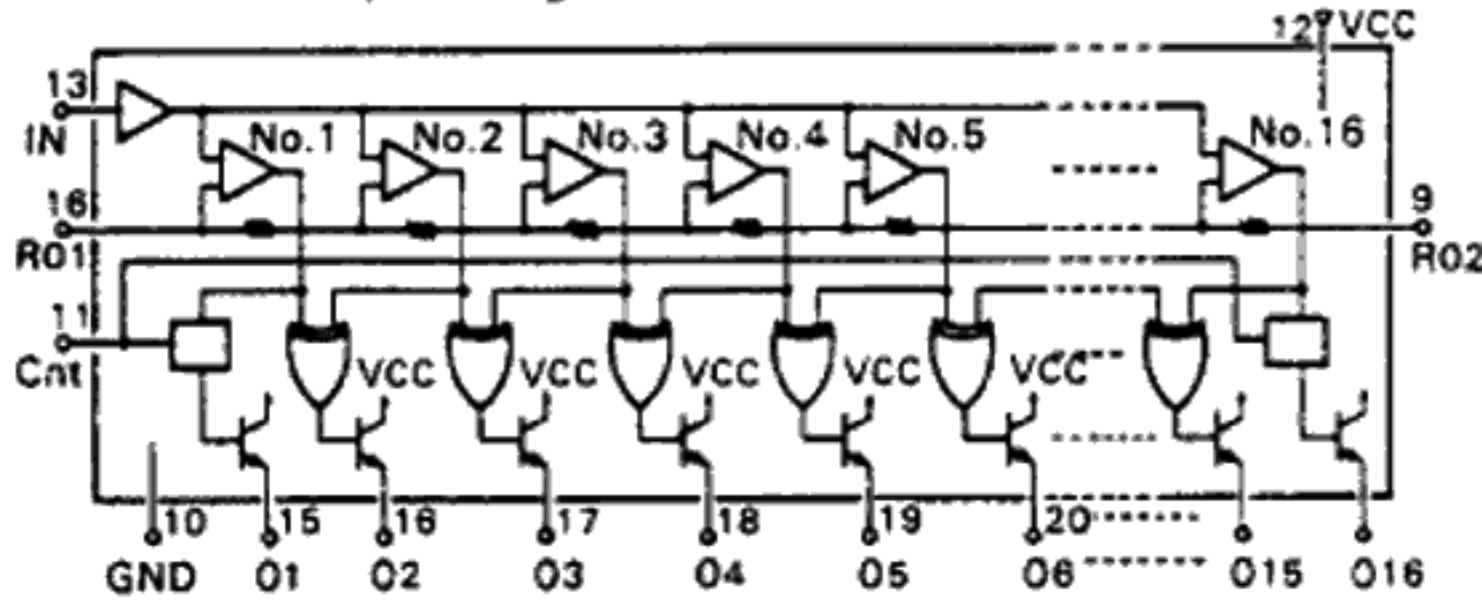

### 3-10. LA5700 (Voltage Regulator IC)

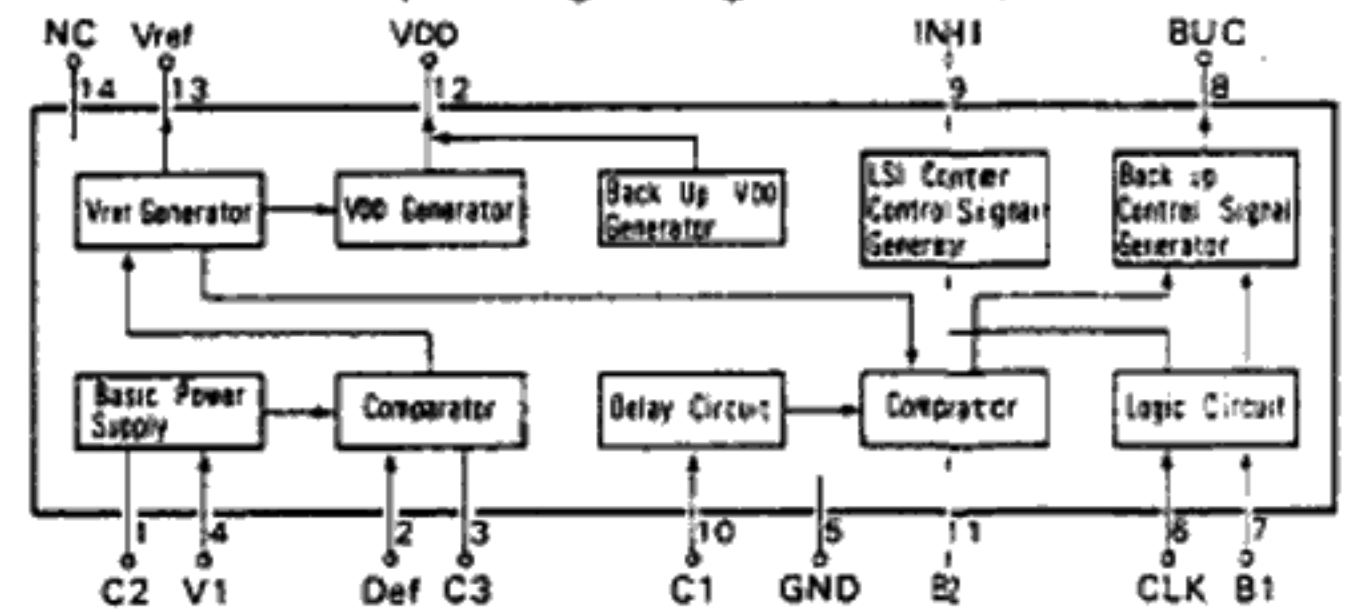

## 4. ADJUSTMENT

### 4-1. FM Adjustment

#### (1) FM IF, VOLTAGE SYNTHESIZER Adjustment and Dial Calibration

- Note: 1. Selector ..... FM  
2. FM Mode ..... MONO

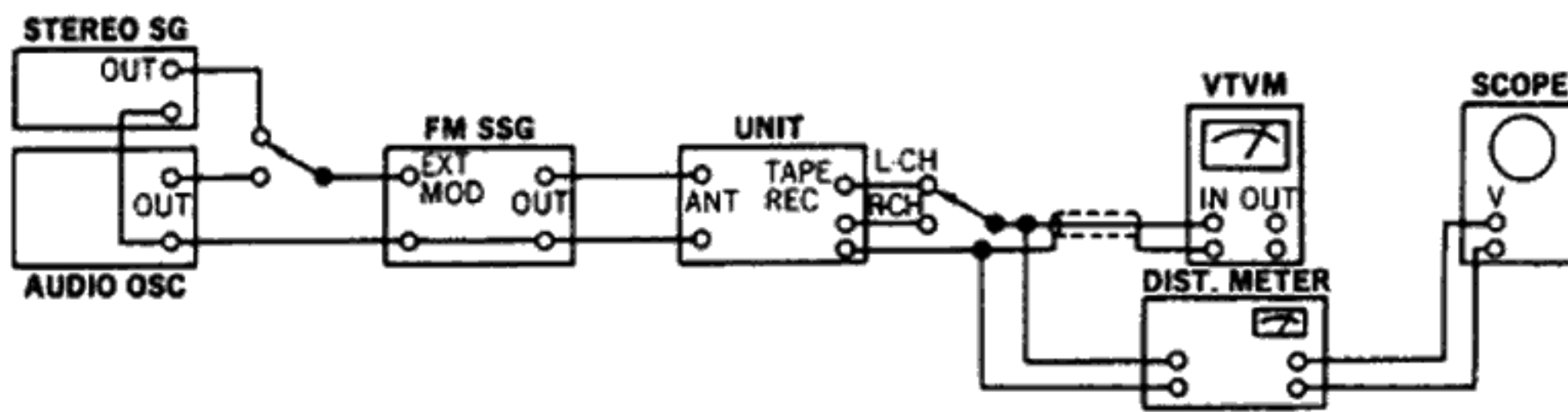

STEP	SUBJECT	FEED SIGNAL		MEASURE OUTPUT	ADJUST	ADJUST FOR	REMARKS
		FROM	TO				
1.	Counter OFF-SET Adj.	110.750 MHz (White) 110.725 MHz (Orange) 110.700 MHz (Red) 110.675 MHz (Blue) 110.650 MHz (Black) No. MOD. FM SSG	Input Terminal No. 58 (F-3321)	Frequency Display	sVR2 (F-3321)	100 MHz	Feed signal for the frequency rank of the ceramic filter used



STEP	SUBJECT	FEED SIGNAL		MEASURE OUTPUT	ADJUST	ADJUST FOR	REMARKS
		FROM	TO				
2.	AM S-curve Adj.	Output 80 dB Genescope	Terminal No. 105 (F-3318)	Lead Wire of eR30 for +, eR34 for -	eT2, eL3 (F-3318)	Steep Linearity of S-curve Make Symmetrical S-curve	
3.	600 kHz RF Adj.	600 kHz ANT Input 30 dB 400 Hz (30% MOD.) AM SSG	ANT Terminal	REC OUT L-CH or R-CH VTVM & Scope	Bar Antenna	Max. Output	
4.	1400 kHz RF Adj.	1400 kHz ANT Input 30 dB 400 Hz (30% MOD.) AM SSG	ANT Terminal	Same as above	eTC1 (F-3318)	Max. Output	

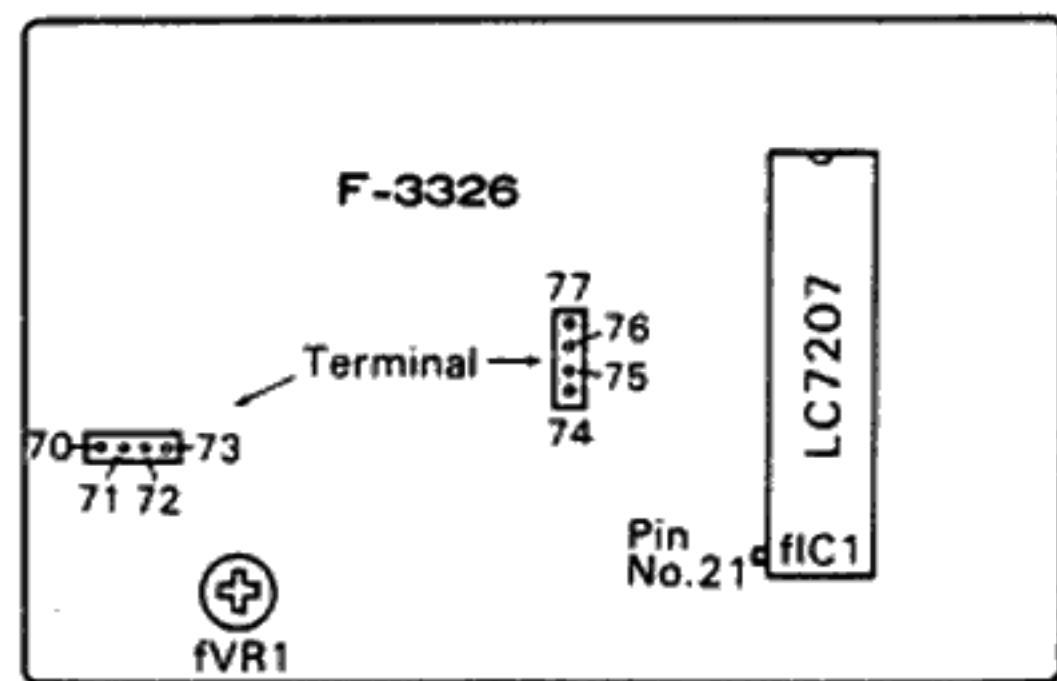
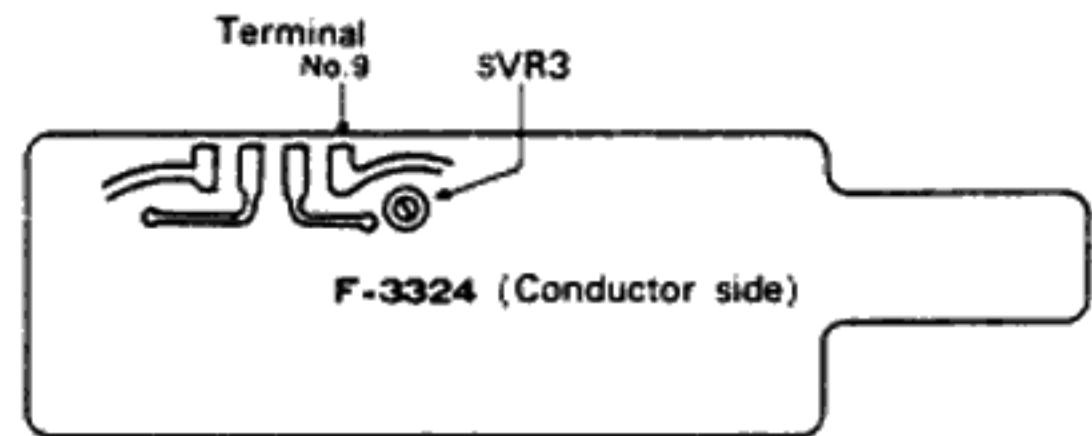
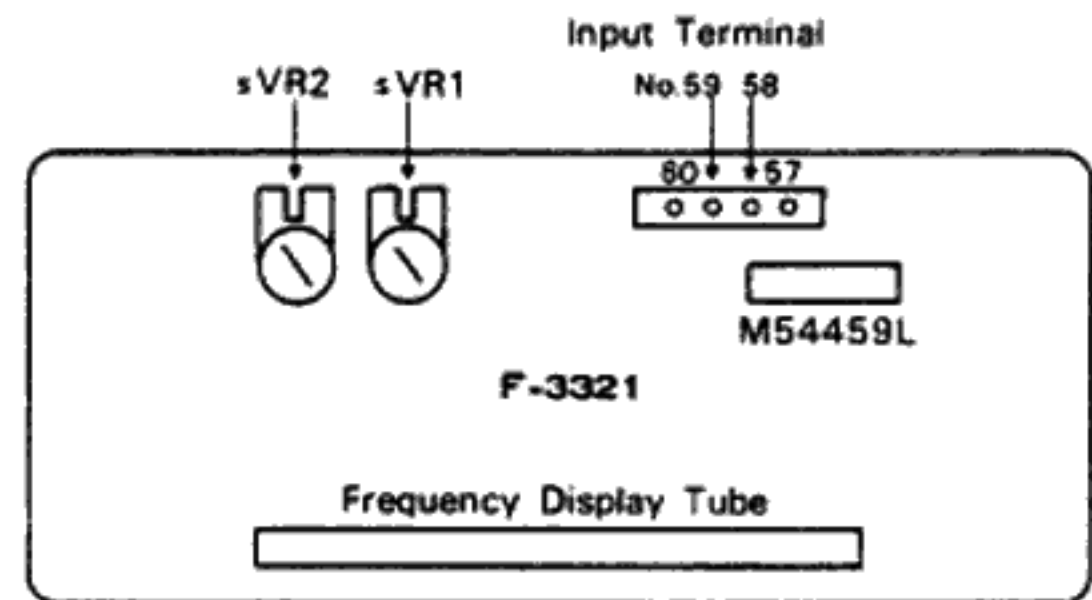
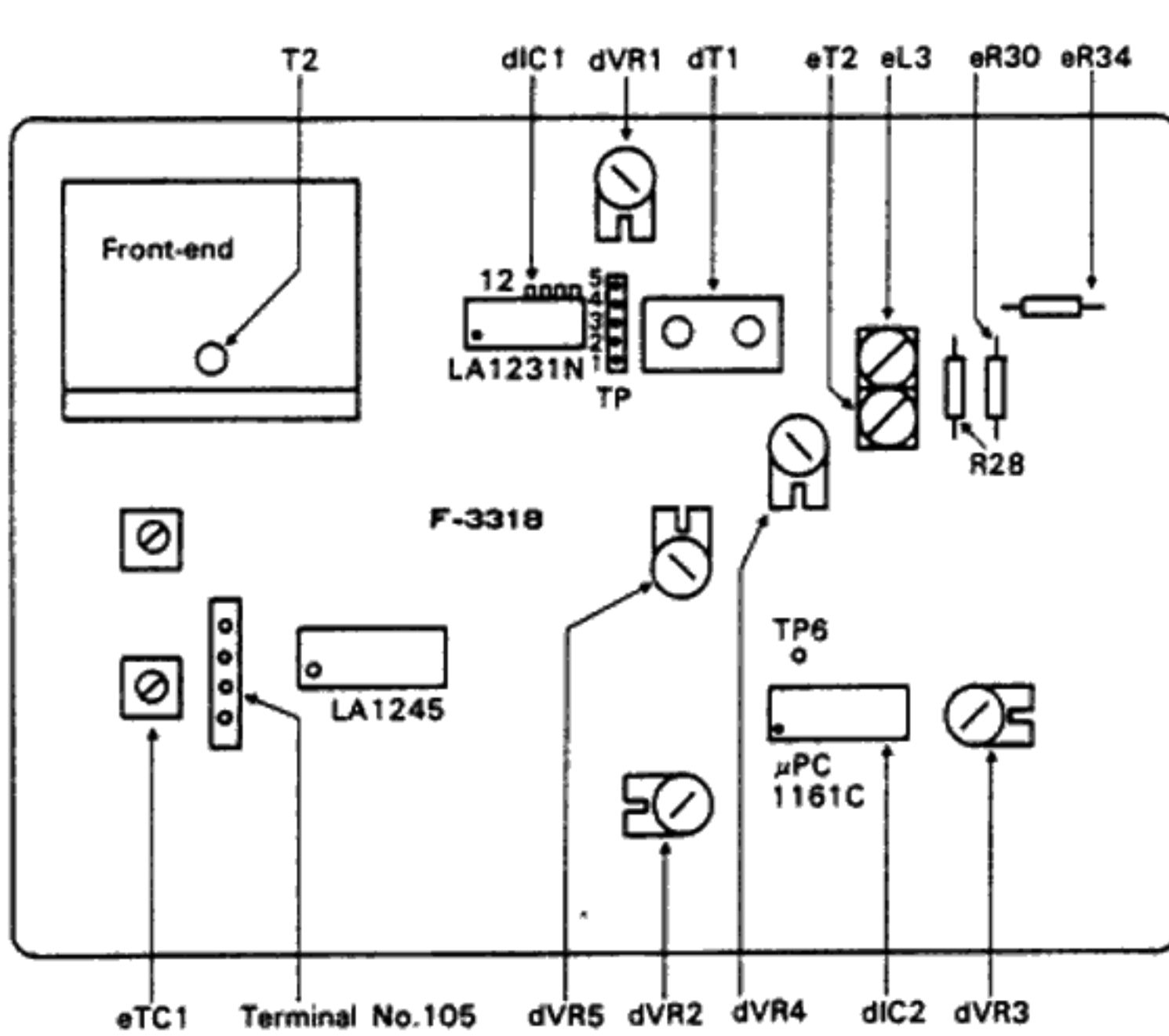

◇ After Adjustment, confirm following Voltages.

- (1) V<sub>ref</sub>  
Terminal No. 75 on F-3326 . . . . . 8.1 V ± 0.5 V
- (2) V<sub>DD</sub>  
Pin No. 21 of fIC<sub>1</sub> on F-3326 . . . . . 9.2 V ± 0.3 V
- (3) V<sub>tune</sub>  
Receive 535 kHz No MOD. Signal from AM SSG.  
Terminal No. 73 on F-3326 . . . . . 1.7 V  
Terminal No. 76 on F-3326 . . . . . 1.2 V

\* In case of V<sub>ref</sub> is not within 8.1 V ± 0.5 V, adjust fVVR1 on F-3326.

4-3. BIAS CURRENT Adjustment (See Top View on page 14, 15)

- Note: 1. Room Temperature . . . . . 18°C ~ 38°C
- 2. Before turning on power switch, turn kVVR1 on F-3327 fully counterclockwise.
- 3. For adjustment, run the unit for more than 3 minutes after the power is switched on.

STEP	SUBJECT	MEASURE OUTPUT	ADJUST	ADJUST FOR	REMARKS
1.	L-CH	Connect DC Volt Meter between emitters of kQ13 & kQ14 on F-3327	kVVR1 L-CH (F-3327)	DC 10 mV	This bias current adjustment converts current value into voltage by Ohms Law.
2.	R-CH	Same as above	kVVR1 R-CH (F-3327)	DC 10 mV	

# 5. PARTS LOCATION & PARTS LIST

•Since some of capacitors and resistors are omitted from parts lists in this Service Manual, refer to the Common Parts List for capacitors & resistors which was appended previously to each Sansui Manual.

5-1. F-3318 Tuner Circuit Board (Stock No. 07094101 = 5900Z/07095701 = 4900Z/00610401 = 3900Z)  
Component Side

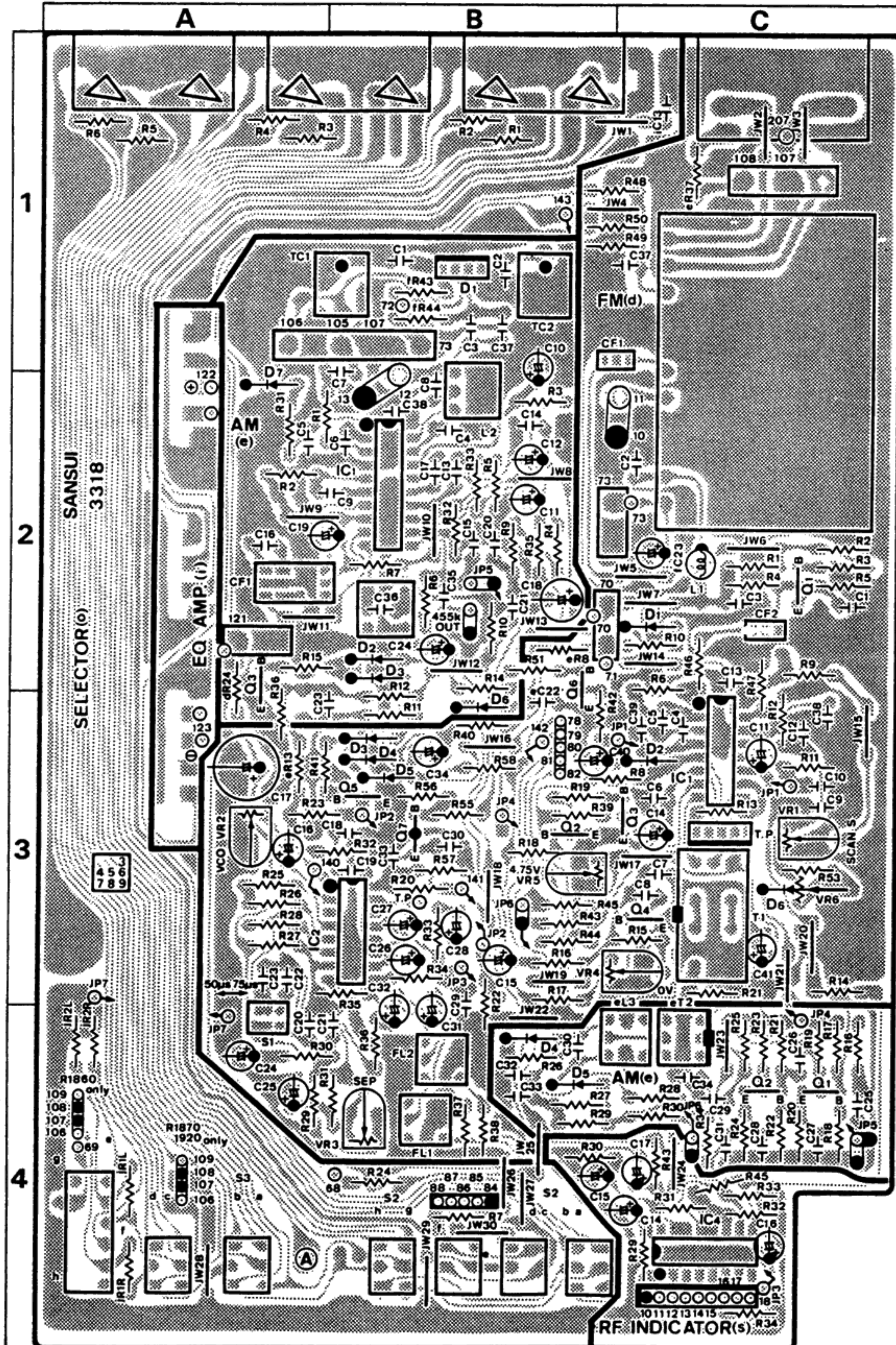

Parts List

Parts No.	Stock No.	Description
<FM Section>		
	07249400	FM Frontend Pack FD256UX
•Transistor		
dQ1	03063401, 2	2SC1674 L, K
dQ2 ~ 5	07194800, 1	2SC1815 Y, GR
dQ7	07194700, 1	2SA1015 Y, GR
•IC		
dIC1	03612300	LA1231N
dIC2	03609900	μPC1161C
•Diode		
dD1 ~ 6	03117600	1S2473D
dCF1	07102210	Ceramic Filter 10.7 MHz
dCF2	07102210	Ceramic Filter 10.7 MHz
dFL1	07248400	Low Pass Filter
dFL2	07248400	Low Pass Filter
dL1	49002800	Inductor 1μH
dT1	07237600	FM IF Coil
dVR1	10370900	Semi Variable Resistor 50 kΩ (B)
dVR2	07218000	Semi Variable Resistor 6.8 kΩ (B), V.C.O. Adj.
dVR3	10371100	Semi Variable Resistor 200 kΩ (B), S.E.P. Adj.
dVR4	07238900	Semi Variable Resistor 50 kΩ (B),

Parts List

Parts No.	Stock No.	Description
dVR5	07239300	Semi Variable Resistor 1MΩ (B)
dS1	07251100	Slide Switch
<AM Section>		
•Transistor		
eQ1, 2	03057900, 1	2SC930 C, D
eQ3	07194800, 1	2SC1815 Y, GR
•IC		
eIC1	07237200	LA1245
•Variable Capacitance Diode		
eD1	07237300	KV1226-EF
•Diode		
eD2 ~ 7	03117600	1S2473D
eTC1, 2	12301000	Trimmer Capacitor 15 pF
eCF1	07250500	Ceramic Filter 455 kHz
eL2	46027100	AM OSC Coil
eL3	07250200	AM IF Coil 455 kHz
eT2	07250100	AM IF Coil 455 kHz
oS2	07247900, 1	Push Switch, input selector
oS3	07242500, 1	Push Switch, tape monitor
•IC		
sIC4	07208100	IR2E01

5-2. F-3325 RF Indicator Circuit Board (Stock No. 07094801 = 5900Z/07096401 = 4900Z/00611001 = 3900Z)

Component Side



Parts List

Parts No.	Stock No.	Description
	07581800	5P L.E.D. Holder
	07581900	1P L.E.D. Holder
•Transistor		
sQ7, 8	07194800, 1	2SC1815 Y, GR

Parts List

Parts No.	Stock No.	Description
sLD17	03193700	Light Emitting Diode SEL'11OS
sLD18~28	07246200	Light Emitting Diode SEL'71OK
sLD29, 30	03193700	Light Emitting Diode SEL'11OS

5-3. F-3332 Equalizer Circuit Board

(Stock No. 00611401 = 3900Z Only)

Component Side

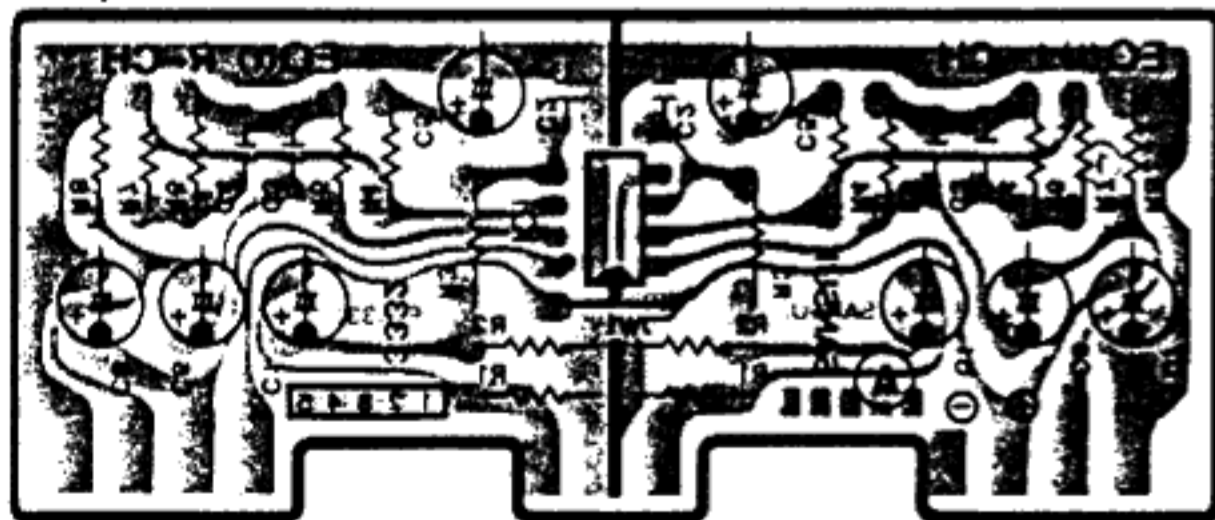

Parts List

Parts No.	Stock No.	Description
•IC	iIC1	07208900 NJM4558D

5-4. F-3333 Equalizer Circuit Board

(Stock No. 00610001 = 5900Z, 4900Z Only)

Component Side

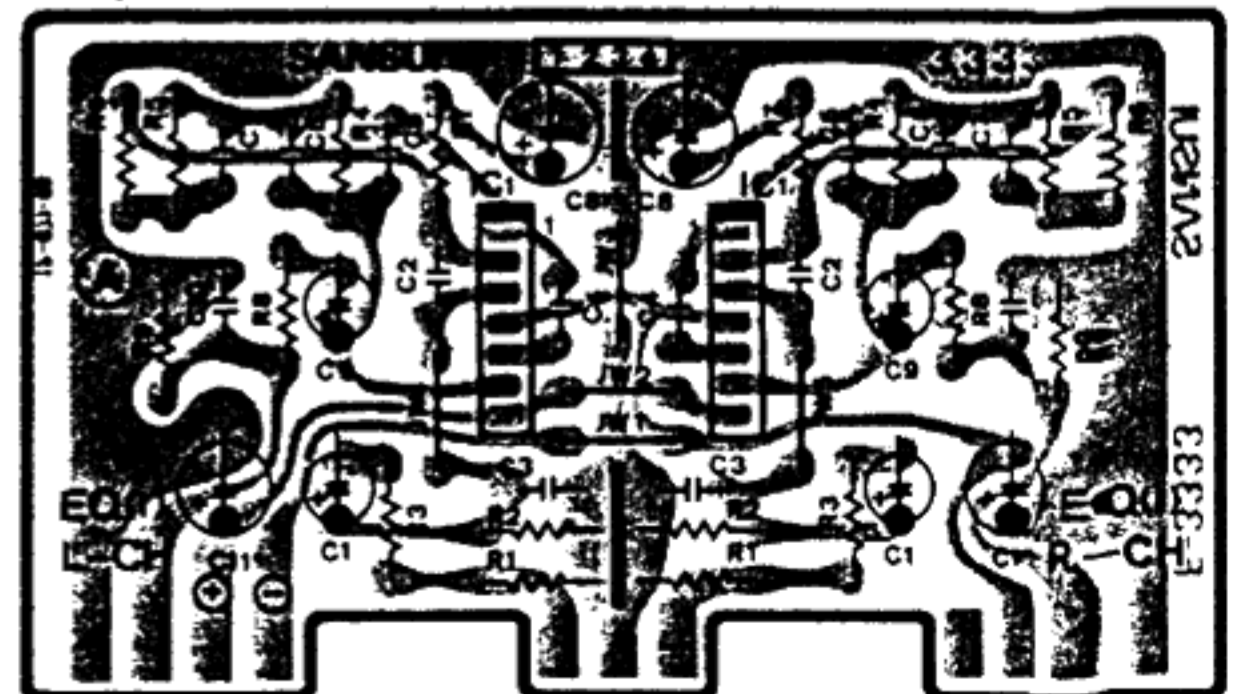

Parts List

Parts No.	Stock No.	Description
•IC	iIC1	07197400 M5214L

5-5. F-3327 Audio & Power Supply Circuit Board (Stock No. 07094901 = 5900Z/07096701 = 4900Z/00611101 = 3900Z)  
Component Side

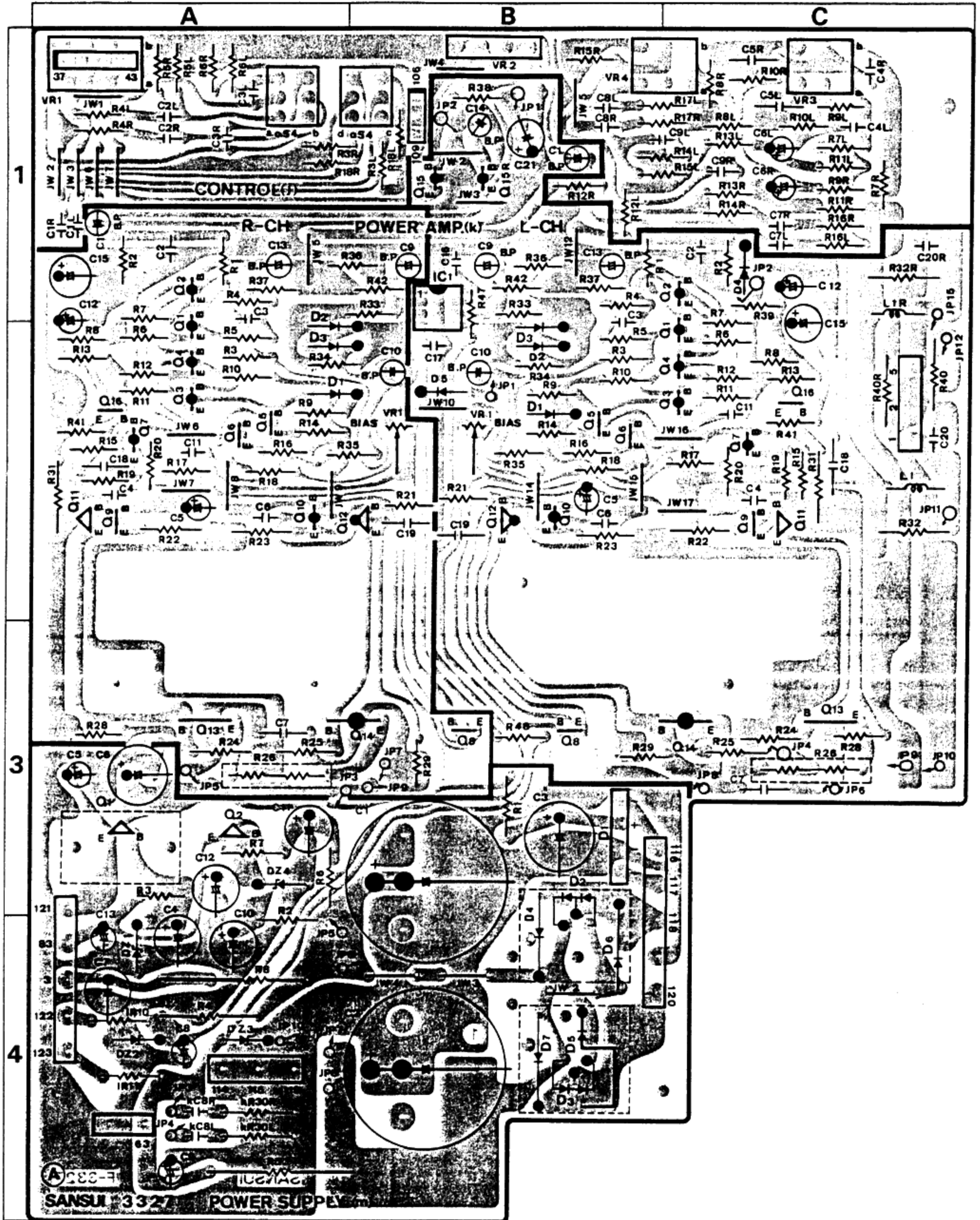

## Parts List

Parts No.	Stock No.	Description
jVR1	07247500	Variable Resistor 150 k $\Omega$ (B), volume (4900Z/3900Z Only)
jVR2	07247600	Variable Resistor 250 k $\Omega$ , balance
jVR3	07247700	Variable Resistor 50 k $\Omega$ (B), bass
jVR4	07247700	Variable Resistor 50 k $\Omega$ (B), treble
●Transistor		
kQ1 ~ 4	03010900, 1	2SA992 F, E
kQ5, 6	07208700, 1	2SC2705 O, Y
kQ7	07208800, 1	2SA1145 O, Y
kQ8	07194800, 1	2SC1815 Y, GR
kQ9	07208700, 1	2SC2705 O, Y
kQ10	07208800, 1	2SA1145 O, Y
kQ11	07206400, 1	2SD600K E, F
kQ12	07206300, 1	2SB631K E, F
kQ13	07235600, 1	2SC2581LB2 O, Y (5900Z)
	03069800, 1	2SC2579LB2 O, Y (4900Z)
	03070000, 1	2SC2577LB2 O, Y (3900Z)
kQ14	07235500, 1	2SA1106LB2 O, Y (5900Z)
	03012900, 1	2SA1104LB2 O, Y (4900Z)
	03013100, 1	2SA1102LB2 O, Y (3900Z)
kQ15	03010900, 1	2SA992 F, E
kQ16	07194800, 1	2SC1815 Y, GR
●IC		
kIC1	03607700	NJM4558D
●Diode		
kD1 ~ 4	03111600	1S2473D
kR26	00091700	0.33 $\Omega$ x 2 5W Ce.R.
kR30	00179000	100 $\Omega$ 1W N.I.R.
kR40	00179000	100 $\Omega$ 1W N.I.R.
kC1	00306800	1 $\mu$ F 50V E.B.
kC7	00380700	22000pF 500V C.C.
kC9	00307500	4.7 $\mu$ F 50V E.B.
kC10	00306600	10 $\mu$ F 50V E.B.
kC13	00305800	2.2 $\mu$ F 25V E.B.
kC14	00306800	1 $\mu$ F 50V E.B.
kC18	00380700	22000pF 500V C.C.
kC19	00380700	22000pF 500V C.C.
kL1	42102900	Inductor 1.5 $\mu$ H
kVR1	10370400	Semi Variable Resistor 1 k $\Omega$ (B), Bias Adj.
●Transistor		
mQ1	03083901, 2	2SD313AL D, E
mQ2	03085201, 2	2SD438 E, F

## Parts List

Parts No.	Stock No.	Description
●Diode		
mD1	03117000	RB-152
mD2	07263700	CTU-22U (5900Z Only)
mD3	07263700	CTU-22U (5900Z Only)
mD4 ~ 7	07224400	UF-21 (4900Z/3900Z Only)
●Zener Diode		
mDZ1	03163200	RD13E C
mDZ2	03164500	RD18E B
	03164600	RD18E C
mDZ3	03171100	RD18F B
	03171200	RD18F C
mDZ4	03165700	RD33E B
mR4	00187400	1.8 k $\Omega$ 2W N.I.R. (5900Z Only)
	00186900	1.5 k $\Omega$ 2W N.I.R. (4900Z Only)
	00185700	1 k $\Omega$ 2W N.I.R. (3900Z Only)
mR5	00103000	1 k $\Omega$ 3W Ce.R. (5900Z Only)
	00105700	820 $\Omega$ 3W Ce.R. (4900Z Only)
	00105500	680 $\Omega$ 3W Ce.R. (3900Z Only)
mR8	00105500	680 $\Omega$ 3W Ce.R. (5900Z Only)
	00190200	470 $\Omega$ 3W N.I.R. (4900Z Only)
mC1	07272300	10000 $\mu$ F 71V E.C. (5900Z Only)
	07208300	8200 $\mu$ F 63V E.C. (4900Z Only)
	00316100	6300 $\mu$ F 50V E.C. (3900Z Only)
mC2	07272300	10000 $\mu$ F 71V E.C. (5900Z Only)
	07208300	8200 $\mu$ F 63V E.C. (4900Z Only)
	00316100	6300 $\mu$ F 50V E.C. (3900Z Only)
dS4	07248200, 1	Push Switch, hi-filter

## 5-6. F-3321 Frequency Indicator Circuit Board (Stock No. 07094301 = 5900Z/07095901 = 4900Z/00610601 = 3900Z)

## Component Side

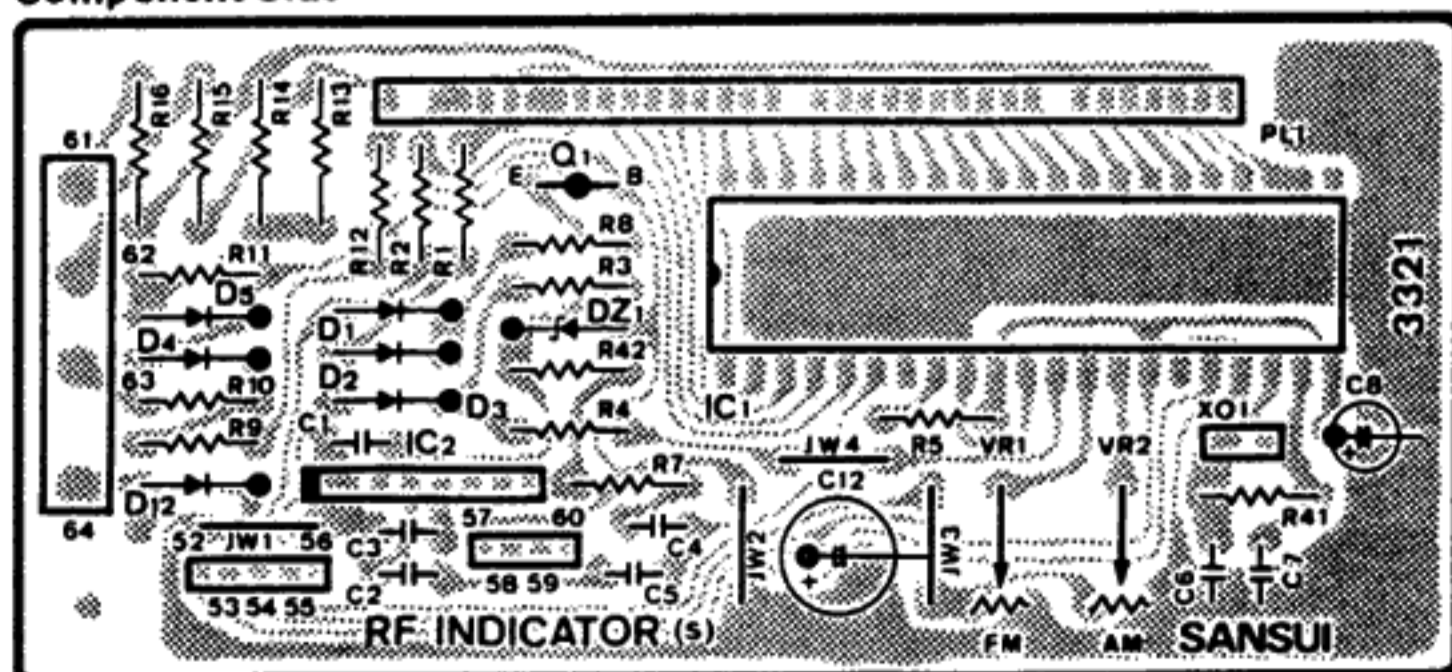

## Parts List

Parts No.	Stock No.	Description
●Transistor		
sQ1	07194700, 1	2SA1015 Y, GR
●IC		
sIC1	07205100	LC7258
sIC2	07233200	M54459L
sXO1	07225300	Quartz Element LN-X-0406
sD1 ~ 5	03117600	1S2473D
sD12	07225500	1N60
sDZ1	07178500	RD5.1E-B (Zener)
sPL1	07235300	FL Indicator FIP7B8S
sVR1	07238700	Semi Variable Resistor 10 k $\Omega$ (B)
sVR2	07238700	Semi Variable Resistor 10 k $\Omega$ (B)

5-7. F-3324 Dial Indicator Circuit Board (Stock No. 07094701 = 5900Z/07096301 = 4900Z/00610901 = 3900Z)

Component Side

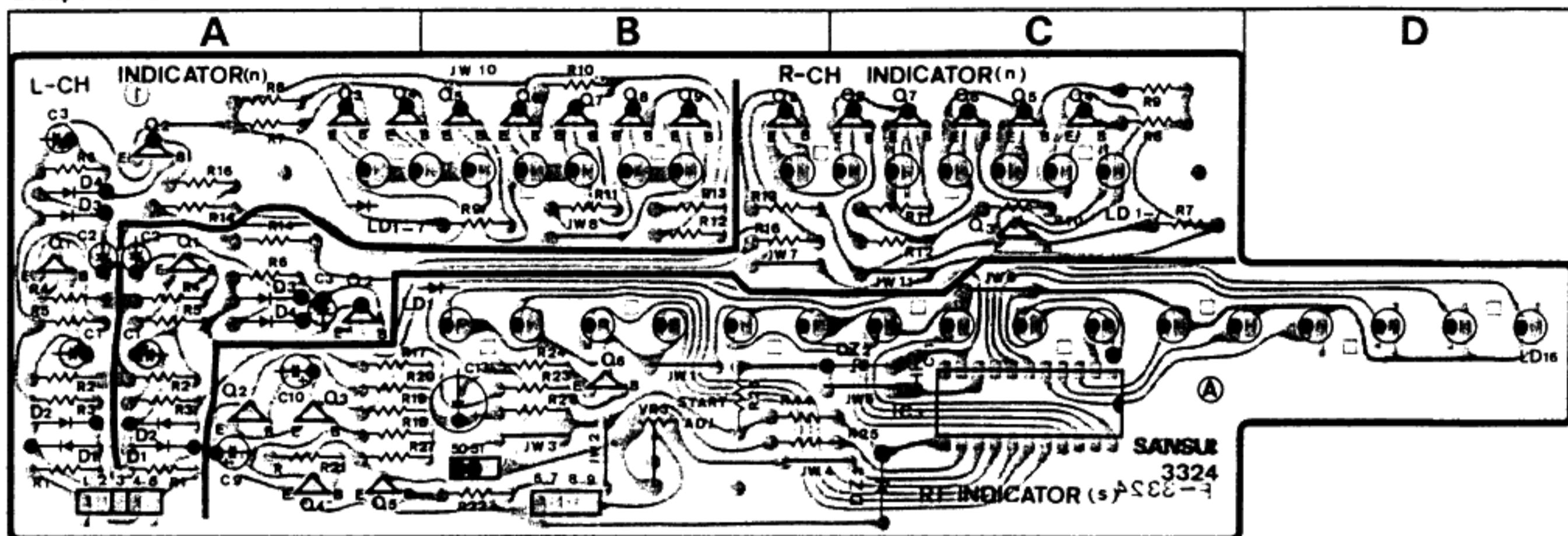

Parts List

Parts No.	Stock No.	Description
<5900Z/4900Z/3900Z>		
•Transistor		
sQ2 ~ 6	07194800, 1	2SC1815 Y, GR
•IC		
sIC3	07204900	LB1473
•Zener Diode		
sDZ2	03158300	EQA01-08R
sDZ3	03158700	EQA01-09S
sLD1	03193700	Light Emitting Diode SEL1110S
sVR3	10370700	Semi Variable Resistor 10 kΩ (B)

Parts List

Parts No.	Stock No.	Description
<5900Z/4900Z Only>		
	07615700	L.E.D. Holder (8-point)
	07594900	L.E.D. Holder (7-point)
•Transistor		
nQ1	07194800, 1	2SC1815 Y, GR
nQ2 ~ 9	07194700, 1	2SA1015 Y, GR
•Diode		
nD1	07225500	1N60
nD2 ~ 4	03111600	1S2473D
nLD1 ~ 7	07243200	Light Emitting Diode GL-5HD5 (Red)

5-8. F-3326 Electronic Tuning Controller Circuit Board (Stock No. 07094601 = 5900Z/07096101 = 4900Z/00610801 = 3900Z)

Component Side

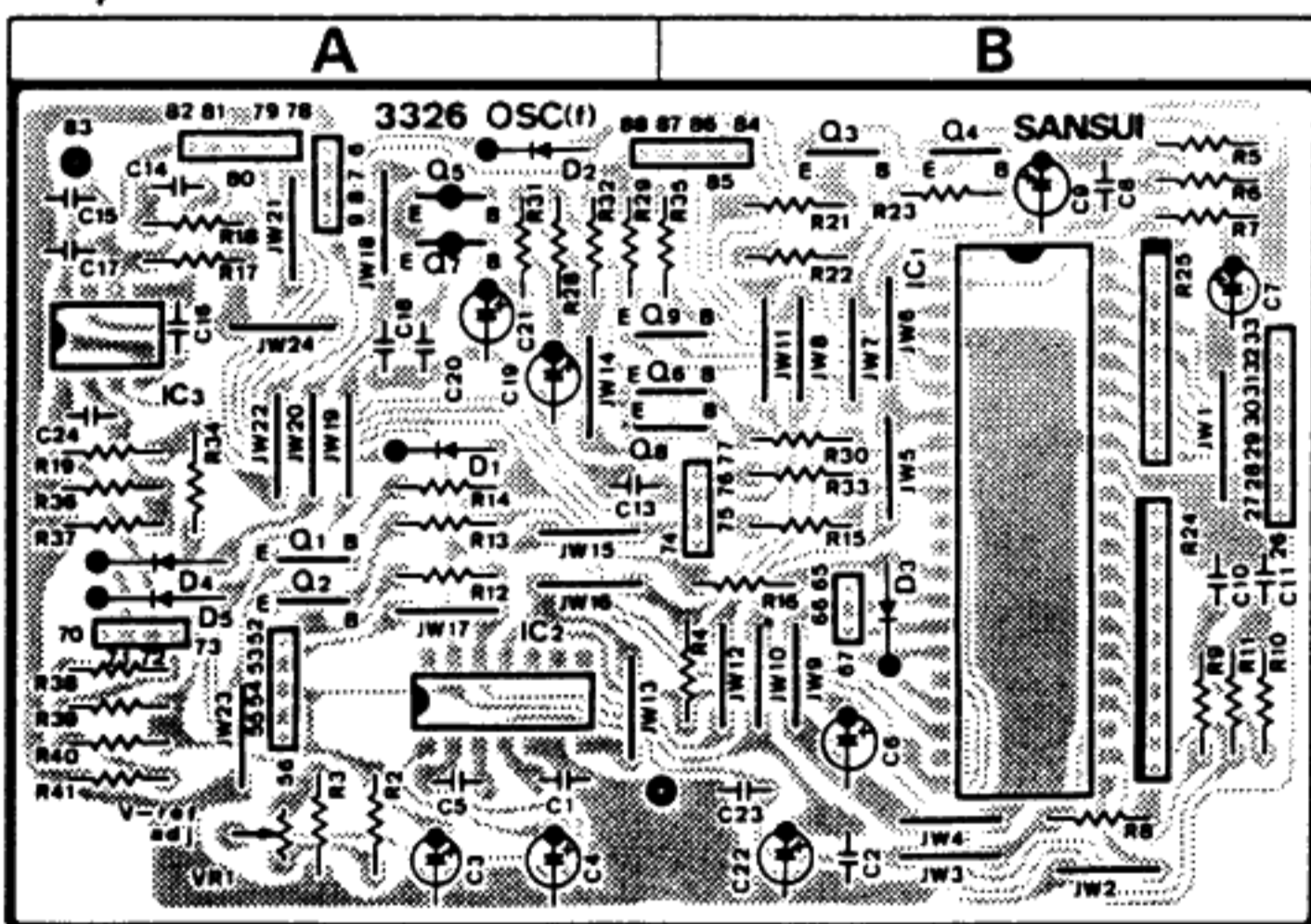

Parts List

Parts No.	Stock No.	Description
•Transistor		
fQ1 ~ 4	07194800, 1	2SC1815 Y, GR
fQ5	03033601, 2	2SB560MP E, F
fQ6	07194800, 1	2SC1815 Y, GR
fQ7	03033601, 2	2SB560MP E, F
fQ8, 9	07194800, 1	2SC1815 Y, GR
•IC		
fIC1	07205000	LC7207
fIC2	07234500	LA5700
fIC3	03607700	NJM4558D
•Diode		
fD1 ~ 7	03117600	1S2473D
fR24	07233900	Ladder Resistor
fR25	07234900	Ladder Resistor
fVR1	10342300	Semi Variable Resistor 2.2 kΩ (B)

**5-9. F-3420 Motor Volume Control Circuit Board**  
(Stock No. 07095201 = 5900Z Only)

Component Side

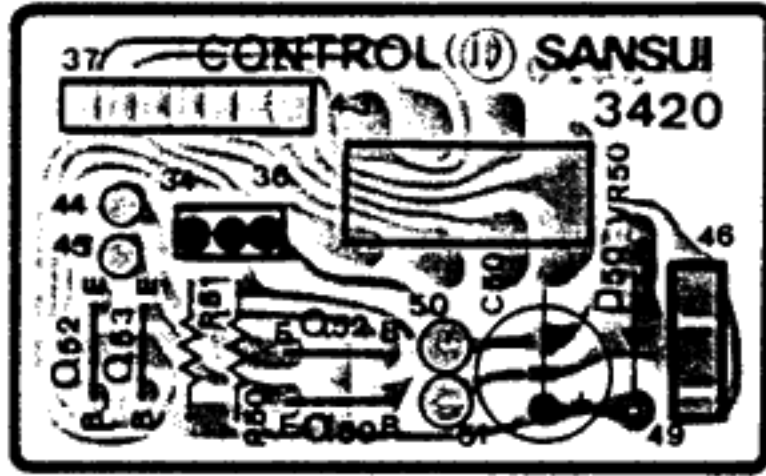

**Parts List**

Parts No.	Stock No.	Description
●Transistor		
jQ50	07206900, 1	2SC2001 M, L
	07254900, 1	2SC1741 Q, R
	03085201, 2	2SD438 E, F
jQ51	07206800, 1	2SA952 M, L
	07254800, 1	2SA854 Q, R
	03033601, 2	2SB450MP E, F
jQ52	07206900, 1	2SC2001 M, L
	07254900, 1	2SC1741 Q, R
	03085201, 2	2SD438 E, F
jQ53	07206800, 1	2SA952 M, L
	07254800, 1	2SA854 Q, R
	03033601, 2	2SB560MP E, F
●Diode		
jD50	03117700	10E-2
jVR1	07242100	Variable Resistor 150 kΩ (B) x 2

● Note:  
The circuit board, F-3319, F-3320, F-3423, F-3419, F-3322 & F-3323 are not supplied as the assembled. However, the individual parts on the circuit board are provided by orders.

**5-10. F-3319 FM Mode/Tuning Level Switch Circuit Board**

**Parts List**

Parts No.	Stock No.	Description
oS1	07248100, 1	Push Switch

**5-11. F-3320 Speaker Selector Sw. Circuit Board**  
(5900Z/4900Z/3900Z)

**Parts List**

Parts No.	Stock No.	Description
oS5	07257700 24306000	Push Switch Head Phone Jack
pS1	11319000	Push Switch, power

**5-12. F-3322 Memory & Preset Switch Circuit Board (5900Z/4900Z/3900Z)**

**Parts List**

Parts No.	Stock No.	Description
fS1 ~ 7	11320900	Push Switch

**5-13. F-3323 Auto Tuning Switch Circuit Board**  
(5900Z/4900Z/3900Z)

**Parts List**

Parts No.	Stock No.	Description
fS8	07246100	Push Switch
fS9	07246100	Push Switch

**5-14. F-3419 Audio Muting Indicator Circuit Board (5900Z Only)**

**Parts List**

Parts No.	Stock No.	Description
	07581900	1P L.E.D. Holder
nLD8	03193700	Light Emitting Diode SEL1 110S

**5-15. F-3422 Voltage Selector Circuit Board**  
(5900Z/4900Z/3900Z)

**Parts List**

Parts No.	Stock No.	Description
<5900Z>		
pF1	07189200	Fuse 6A 250V (100V ~ 120V)
	07188800	Fuse 3A 250V (220V ~ 240V)
<4900Z>		
pF1	07189100	Fuse 5A 250V (100V ~ 120V)
	07188700	Fuse 2.5A 250V (220V ~ 240V)
<3900Z>		
pF1	07189000	Fuse 4A 250V (100V ~ 120V)
	07188600	Fuse 2A 250V (220V ~ 240V)

**5-16. F-3423 Volume Sw. Circuit Board (5900Z Only)**

**Parts List**

Parts No.	Stock No.	Description
jS50	07246100	Push Switch
jS51	07246100	Push Switch

● Abbreviations

C.R. . . . .	Carbon Resistor	E.L. . . . .	Low Leak Electrolytic Capacitor
S.R. . . . .	Solid Resistor	E.B. . . . .	Bi-Polar Electrolytic Capacitor
Ce.R. . . . .	Cement Resistor	E.BL. . . . .	Low Leak Bi-Polar Electrolytic Capacitor
M.R. . . . .	Metal Film Resistor	Ta.C. . . . .	Tantalum Capacitor
F.R. . . . .	Fusing Resistor	F.C. . . . .	Film Capacitor
N.I.R. . . . .	Non-Inflammable Resistor	M.P. . . . .	Metalized Paper Capacitor
C.C. . . . .	Ceramic Capacitor	P.C. . . . .	Polystyrene Capacitor
C.T. . . . .	Ceramic Capacitor, Temperature Compensation	G.C. . . . .	Gimmic Capacitor
E.C. . . . .	Electrolytic Capacitor		

## 6. OTHER PARTS

### 6-1. Front View <5900Z>

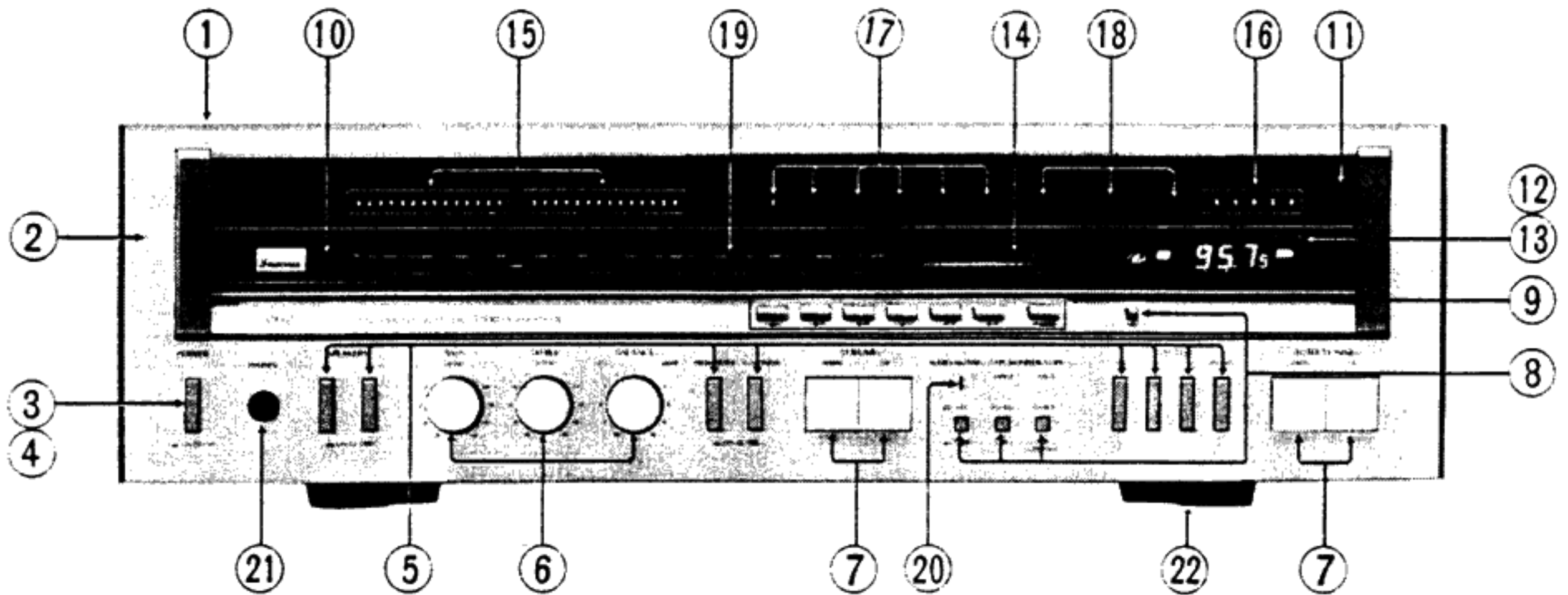

### 6-2. Top View <5900Z>

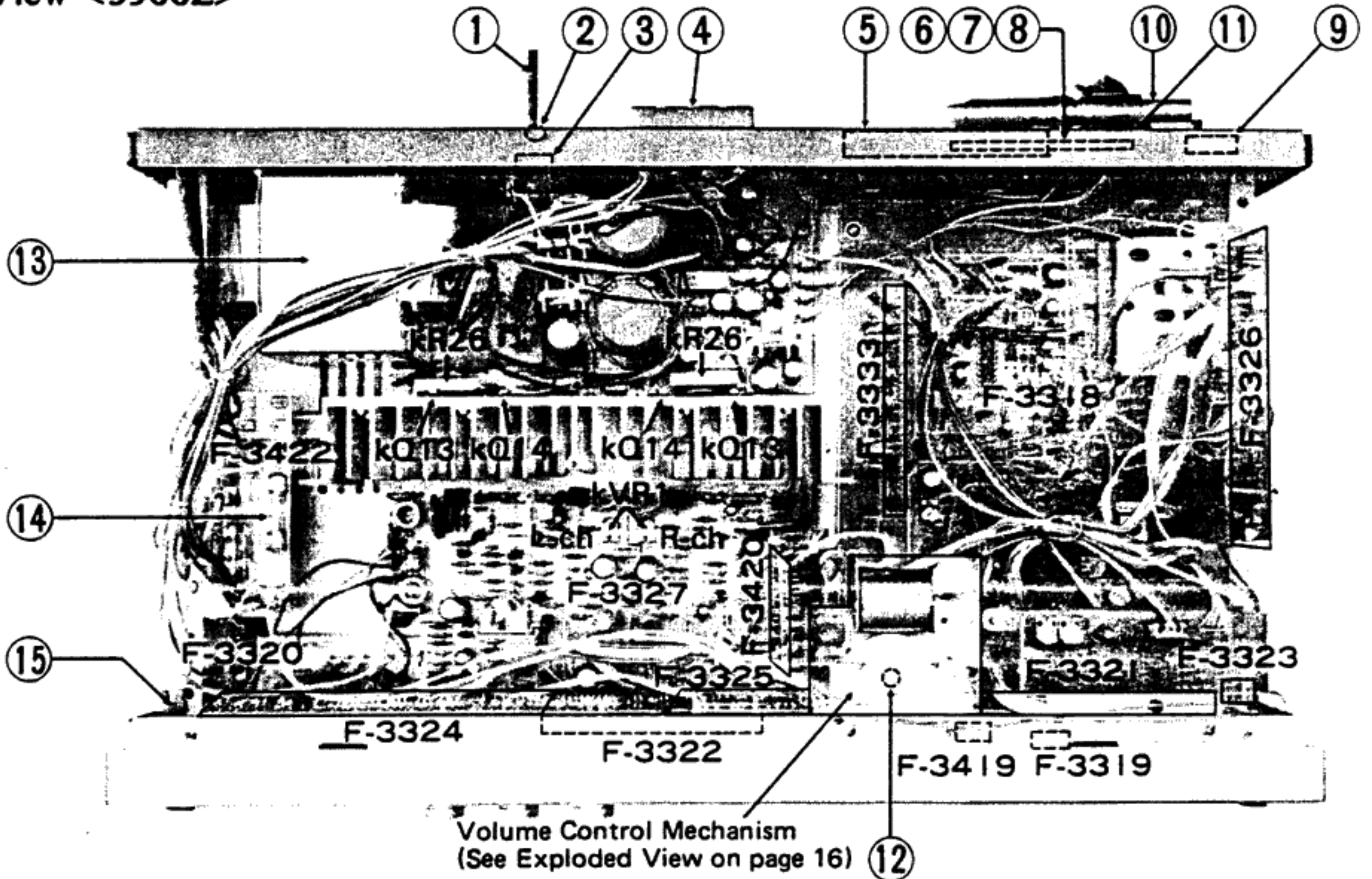

#### Parts List <Front View>

Parts No.	Stock No.	Description
1	07616600	Bonnet
2	07618310	Front Panel Ass'y
	07616900	Front Glass
	07615400	Panel Side Frame (L)
	07615500	Panel Side Frame (R)
3	07579800	Push Knob, power
4	11319000	Push Switch
5	07579800	Push Knob, speakers, hi-filter
		loudness, selector
	07581500	Push Knob Guide
6	07615600	TY-Knob, bass, treble, balance
7	07652100	Push Knob Ass'y, volume, auto tuning
8	07580100	Push Knob, auto muting, tape mon./copy, FM mode/tuning level
	07580900	Push Knob Guide
9	07649810	Preset Knob Ass'y
10	07617300	Dial Scale
11	07616800	Dial Back Plate
12	07616300	Smoked Plate
13	07235300	FL Indicator FIP7B8S
14	07600300	Indicator Film
15	07615800	Indicator 14-Point
16	07615900	Indicator 5-Point
17	07616000	Indicator 1-Point
18	07616100	Indicator 1-Point (Red)
19	07616200	Indicator 8-Point
20	07578000	Indicator (Red)
21	24306000	Head Phone Jack
22	55073500	Leg

#### Parts List <Top View>

Parts No.	Stock No.	Description
1	38004700	Power Cord
2	39106000	Strain Relief
3	07189600	AC Outlet
4	07249300	Speaker Terminal, system A, B
5	07563310	Battery Case Ass'y
6	07249100	4P Input Terminal, tape 1 play/rec
7	07249100	4P Input Terminal, tape 2 play/rec
8	07249100	4P Input Terminal, phono, aux
9	22902600	4P Antenna Terminal
10	07236900	AM Bar Antenna
11	22301500	Ground Terminal
12	04006600	Pilot Lamp 8V 150 mA
13	15001301	Power Transformer
14	07189200	Power Fuse 6A 250 V (100 V ~ 120 V)
	07188800	Power Fuse 3A 250 V (220 V ~ 240 V)
15	04007600	Pilot Lamp 8V 300 mA



6-3. Front View <4900Z/3900Z>

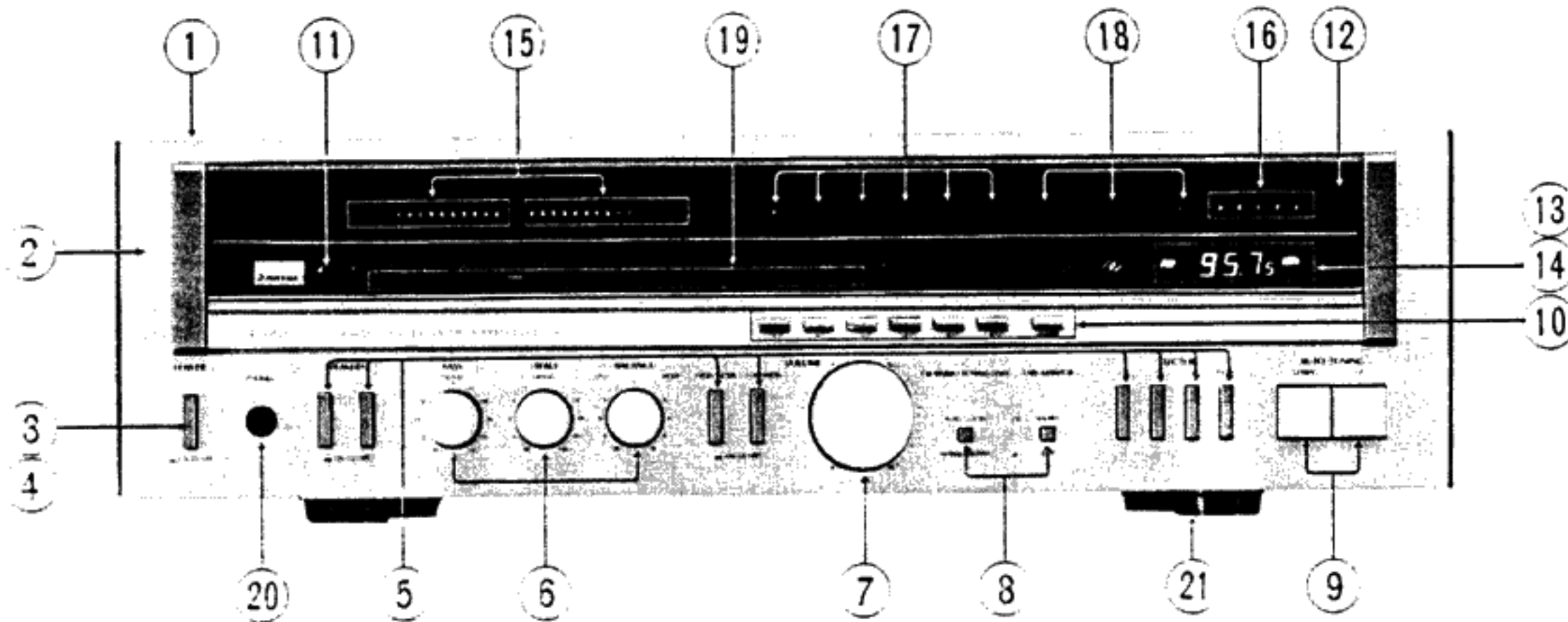

6-4. Top View <4900Z/3900Z>

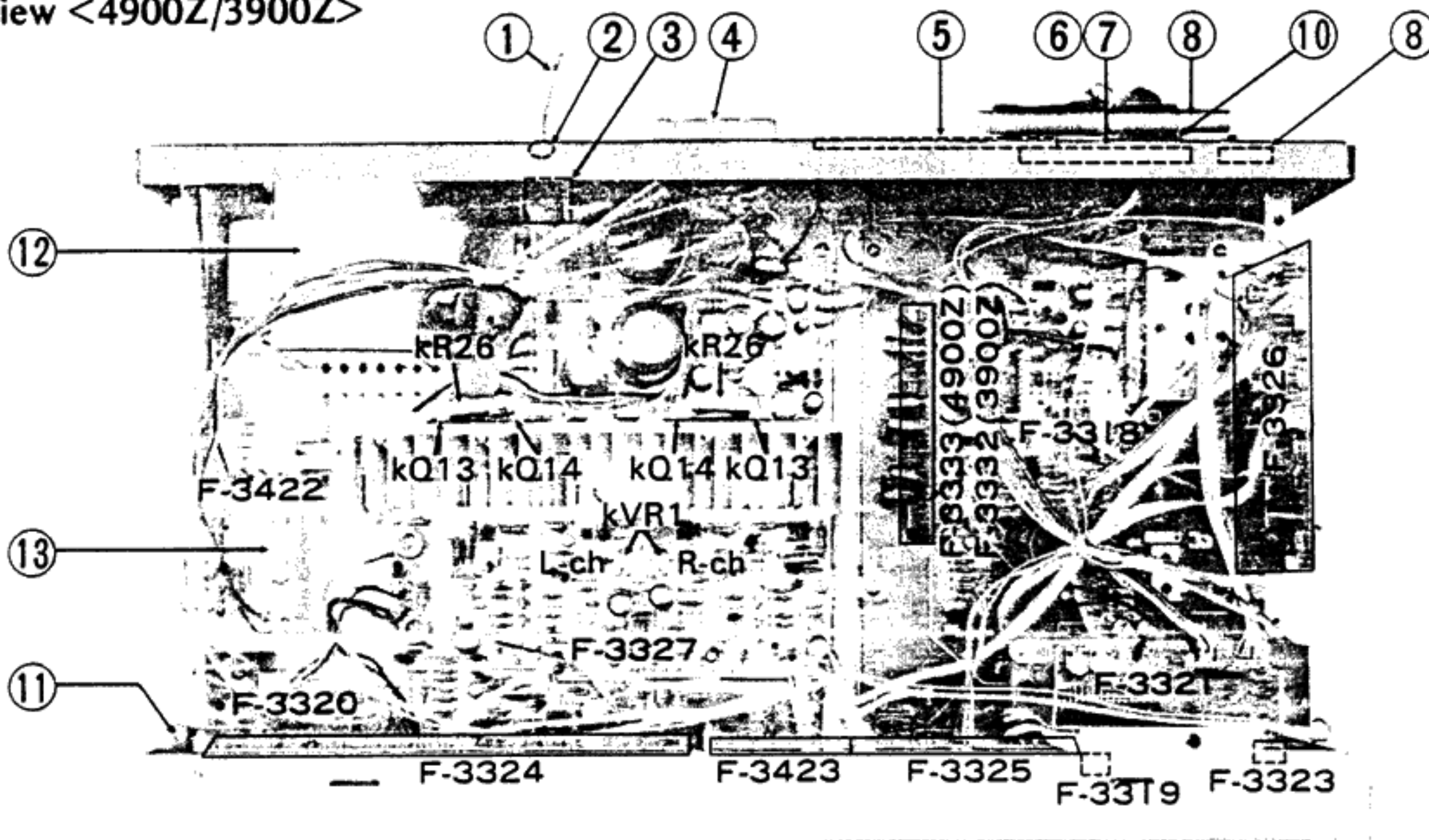

Parts List <Front View>

Parts No.	Stock No.	Description
1	07616600	Bonnet
2	07640210	Front Panel Ass'y <4900Z>
	07653010	Front Panel Ass'y <3900Z>
	07616900	Front Glass
	07615400	Panel Side Frame (L)
	07615500	Panel Side Frame (R)
3	07579800	Push Knob, power
4	11319000	Push Switch
5	07579800	Push Knob, speakers, hi-filter, loudness selector
	07581500	Push Knob Guide
6	07615600	TY-Knob, bass, treble, balance
7	07618700	TY-Knob, volume
8	07580100	Push Knob, FM mode/tuning level tape mon.
	07580900	Push Knob Guide
9	07652100	Push Knob Ass'y, auto tuning
10	07649810	Preset Knob Ass'y
11	07638100	Dial Scale
12	07638500	Dial Back Plate <4900Z>
	07639200	Dial Back Plate <3900Z>
13	07616300	Smoked Plate
14	07235300	FL Indicator FIP7B8S
15	07615800	Indicator 14-Point <4900Z Only>
16	07615900	Indicator 5-Point
17	07616000	Indicator 1-Point
18	07616100	Indicator 1-Point (Red)
19	07616200	Indicator 8-Point
20	24306000	Head Phone Jack
21	55073500	Leg

Parts List <Top View>

Parts No.	Stock No.	Description
1	38004700	Power Supply Cord
2	39106000	Strain Relief
3	07189600	AC Outlet
4	07249300	Speaker Terminal, system A, B
5	07563310	Battery Case Ass'y
6	07249100	4P Input Terminal, tape play/rec
7	07249100	4P Input Terminal, phono, aux
8	22902600	4P Antenna Terminal
9	07236900	AM Bar Antenna
10	22301500	Ground Terminal
11	04007600	Pilot Lamp 8 V 300 mA
12	15001401	Power Transformer <4900Z>
	15001501	Power Transformer <3900Z>
13	07189100	Fuse 5A 250V (100V ~ 120V) <4900Z>
	07188700	Fuse 2.5A 250V (220V ~ 240V) <4900Z>
	07189000	Fuse 4A 250V (100V ~ 120V) <3900Z>
	07188600	Fuse 2A 250V (220V ~ 240V) <3900Z>

## 7. EXPLODED VIEW OF VOLUME CONTROL MECHANISM

<5900Z Only>

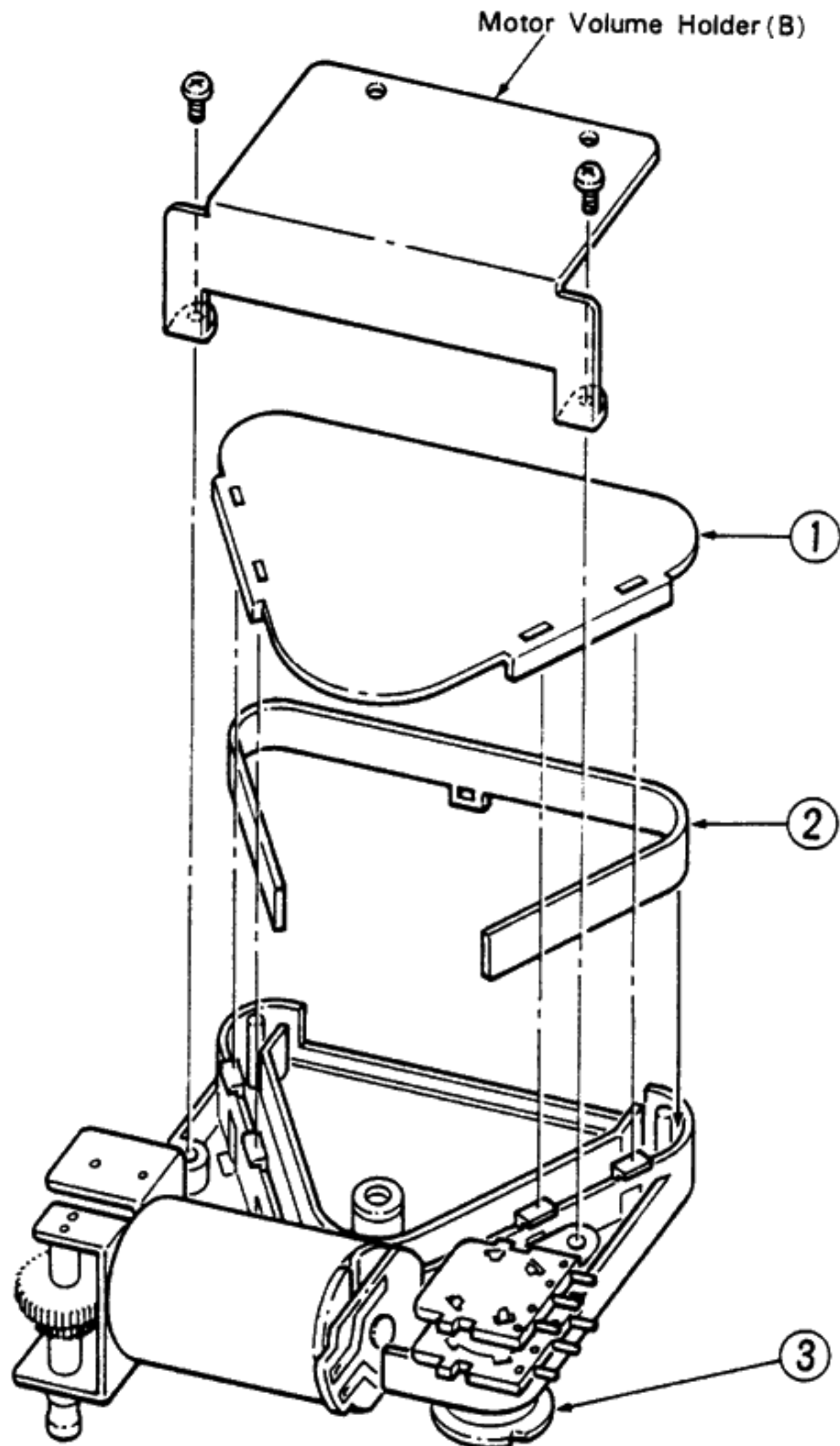

### Parts List

Parts No.	Stock No.	Description
1	07600400	Housing Cover
2	07600300	Indicator Film
3	07600500	Pulley D-17
4	07600910	Tension Ass'y
5	07233400	Pulley (Small)
6	07600210	Housing
7	07600600	Film Guide
8	07234000	Motor Unit (B)
9	07242100	Variable Resistor 150k $\Omega$ (B) x 2

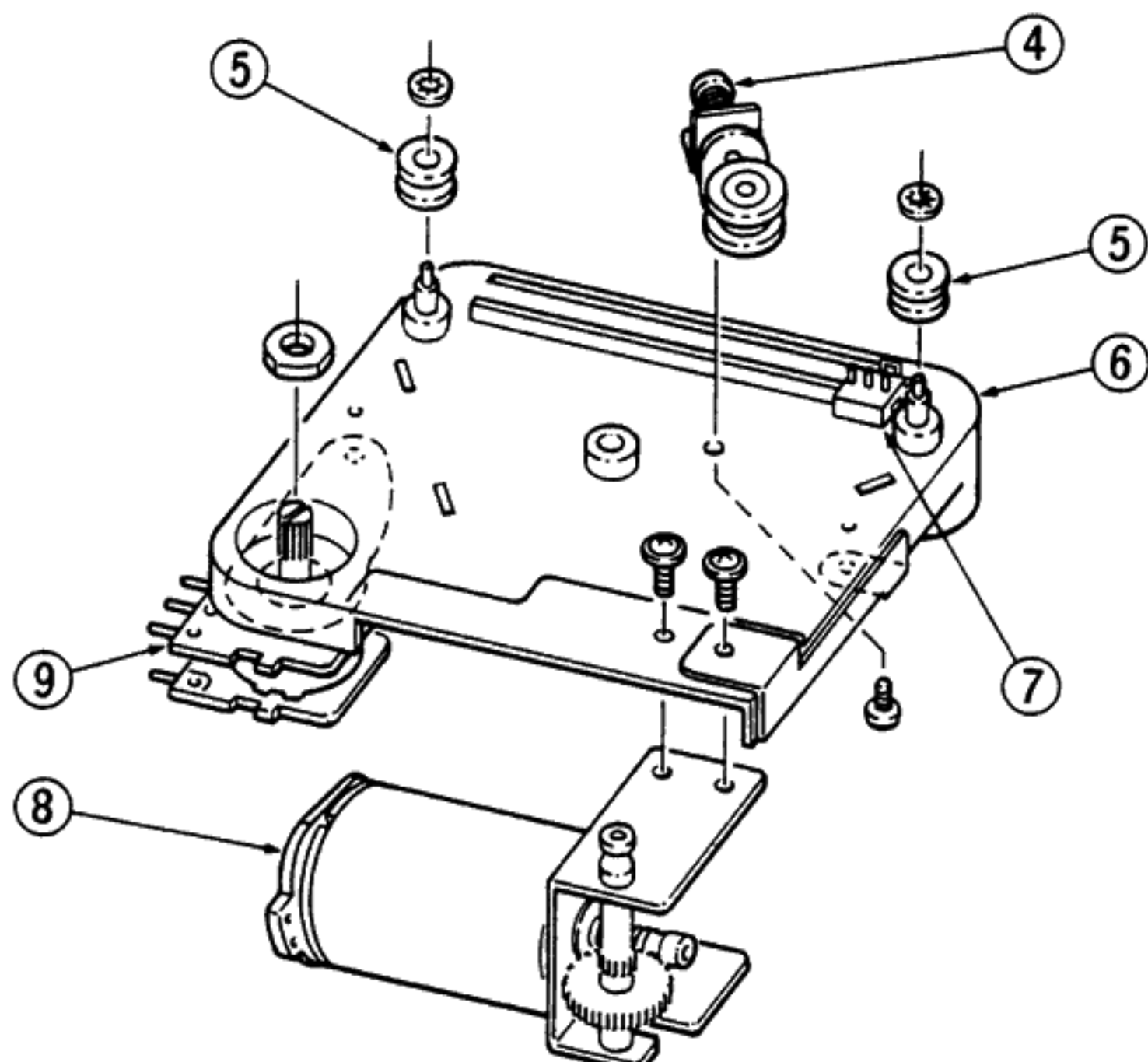

**8. SCHEMATIC DIAGRAM** 8-1. Tuner Section <5900Z, 4900Z, 3900Z>



- 1**
- 2SA854
  - 2SA852
  - 2SA992
  - 2SA1015
  - 2SA1145
  - 2SB560MP
  - 2SC930
  - 2SC1674
  - 2SC1741
  - 2SC1815
  - 2SC2708
  - 2SD438
  - 2SC2001
  - IN60
  - 10E-2
  - 1S2473D
  - UF21
  - RB152
  - 2SA1102
  - 2SA1104
  - 2SC2577
  - 2SC2579
  - 2SC2581
  - 2SD313AL
  - 2SD313AL
  - NJM4558D
  - M52121L
  - LA1231N
  - PC1167C
  - LA5700
  - LC7207
  - LC7258
  - SEL1110S
  - SEL1710K
  - UL5HD5
  - KV1226-EF
  - CTU22U
  - M54459L
  - LB1473
  - LA1245
  - IR2E01
- 2**
- 3**
- 4**
- 5**

SW/B01  
 A Ceramic  
 B Nylon  
 C Von Inflammable Resistor  
 S Sinter  
 DZL RDS1EC



## 9. THREADING OF VOLUME CONTROL

1. Turn the volume control fully clockwise.
2. Thread the string in numerical order from 1 to 16 as Fig. 9-1.
3. Position the indicator film & the film guide at end of right side.
4. Lock the string to the film guide with locking paint. (See Fig. 9-2).

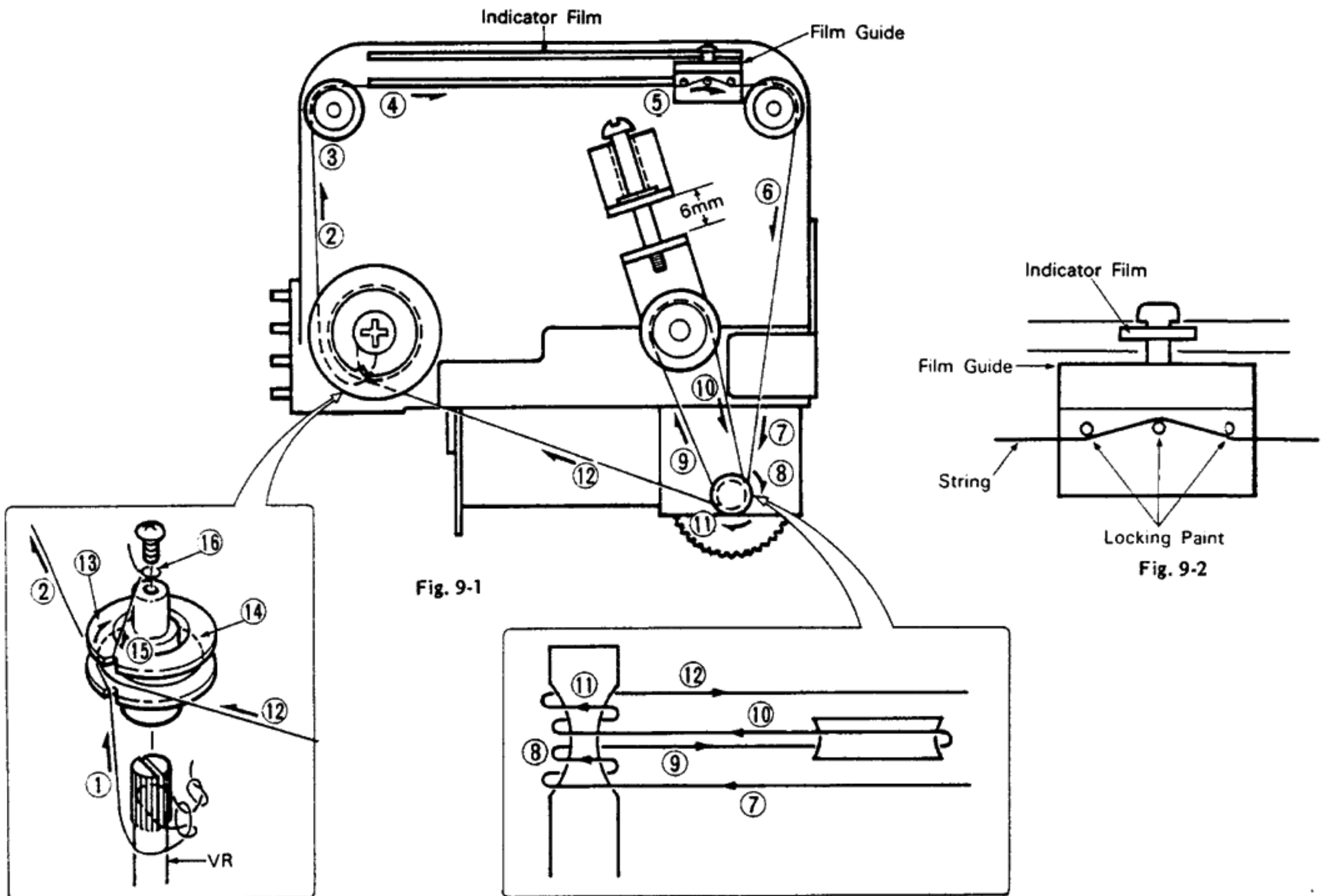

## 10. PACKING LIST

Parts No.	Stock No.	Description
	91166920	Vinyl Cover
	07621000	Stylofoam Packing
	07620900	Carton Case <5900Z>
	07640300	Carton Case <4900Z>
	07656500	Carton Case <3900Z>

## 11. ACCESSORY PARTS LIST

Stock No.	Description
07577700	Operating Instruction <5900Z>
07577800	Operating Instruction <4900Z>
07642900	Operating Instruction <3900Z>
38201200	FM Antenna

