

SERVICE MANUAL

AM/FM STEREO RECEIVER **SANSUI 771**

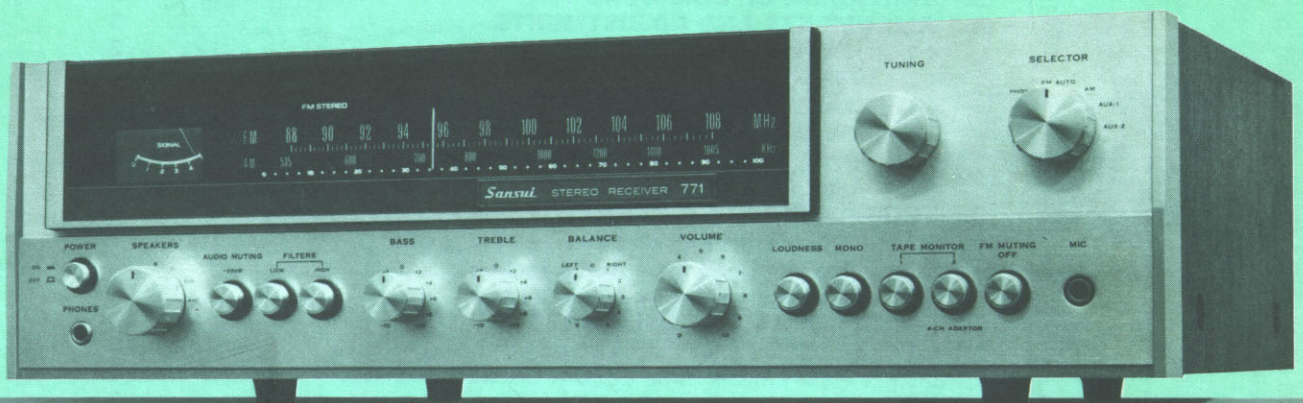

Sansui

SANSUI ELECTRIC CO., LTD.

This service manual is designed for service engineers to repair, adjust, maintain and order the replacement parts of the 771 correctly. When ordering the parts, use the stock number and parts name specifically referring to the Parts Locations & Parts List. For general usage and maintenance of the unit, please refer to the Operating Instructions attached with the unit.

TABLE OF CONTENTS

<u>Section</u>	<u>Title</u>	<u>Page</u>
1.	SPECIFICATIONS	2
2.	BLOCK DIAGRAM AND LEVEL DIAGRAM	3
2-1.	Block Diagram	3, 4
2-2.	Level Diagram	4
3.	THREADING OF DIAL CORD	5
4.	ALIGNMENTS AND ADJUSTMENTS	6
4-1.	Driver Circuit Board Adjustment	6
4-2.	FM IF Alignment	7
4-3.	FM Dial Calibration and RF Alignment	7, 8
4-4.	FM Signal Meter, Mono Distortion and Muting Adjustment	8
4-5.	MPX Alignment	9
4-6.	AM IF, Dial Calibration, RF and Signal Meter Alignment	9, 10
5.	TROUBLESHOOTING CHART	11
5-1.	Troubleshooting on Power Supply Section	11
5-2.	Troubleshooting on Audio Section	11
5-3.	Troubleshooting on Tuner Section	11, 12
6.	PARTS LOCATIONS AND PARTS LIST	13
6-1.	F-1479D Tuner Circuit Board	13, 14, 15
6-2.	F-1504 Mic & Tone Control Circuit Board	15
6-3.	F-1503 Equalizer Circuit Board	16
6-4.	F-1505 Filter Circuit Board	17
6-5.	F-1490 De-emphasis Circuit Board	17
6-6.	F-1499A Driver Circuit Board	17, 18
6-7.	F-1500C Power Circuit Board	19, 20
6-8.	Other Parts (Front Side)	21, 22
6-9.	Other Parts (Top Side)	23
6-10.	Other Parts (Bottom Side)	23
7.	SCHEMATIC DIAGRAM OF TUNER SECTION	24
8.	SCHEMATIC DIAGRAM OF AUDIO SECTION	25
9.	PACKING LIST	26
10.	ACCESSORY PARTS LIST	26
11.	MAINTENANCE	26
11-1.	Voltage Adjustment	26

1. SPECIFICATIONS

AUDIO SECTION

POWER OUTPUT (at rated distortion)
 MUSIC POWER (IHF).....140W (4Ω 1,000Hz)
 110W (8Ω 1,000Hz)

CONTINUOUS POWER
 (Each Channel Driven)..55/55W (4Ω 1,000Hz)
 45/45W (8Ω 1,000Hz)
 (Both Channels Driven)..40+40W (8Ω 1,000Hz)
 32+32W
 (8Ω 20 to 20,000Hz)

TOTAL HARMONIC DISTORTION
 (at rated power output)
 OVERALL (from AUX)less than 0.5%

INTERMODULATION DISTORTION
 (at rated power output, 70Hz : 7,000Hz=4 : 1
 SMPTE method)
 OVERALL (from AUX)less than 0.5%

POWER BANDWIDTH (IHF) 15 to 40,000Hz

FREQUENCY RESPONSE (at 1 Watt power output)
 OVERALL (from AUX)15 to 30,000Hz ± 1.0 dB
 -2.0 dB

EQUALIZATION (at TAPE REC output)
 RIAA Curve
 (30 to 15,000Hz ± 1.0 dB)

LOAD IMPEDANCE4 to 16Ω

DAMPING FACTOR60 (8Ω)

CHANNEL SEPARATION (1,000Hz, at rated power output)
 PHONObetter than 45dB
 AUX-1, 2better than 45dB

HUM AND NOISE (IHF)
 PHONObetter than 70dB
 AUX-1, 2better than 80dB

INPUT SENSITIVITY AND IMPEDANCE
 (1,000Hz, for rated power output)
 PHONO2.5mV 50kΩ
 (Max. input capability: 200mV at rated distortion)
 MIC (monophonic)2.5mV 50kΩ
 AUX-1, 2100mV 50kΩ

TAPE-1
 PLAY Pin Jacks100mV 50kΩ
 REC/PLAY DIN Socket ..100mV 50kΩ

TAPE-2 (4-CH ADAPTOR)
 PLAY Pin Jacks100mV 50kΩ

RECORDING OUTPUT
 TAPE-1
 REC Pin Jacks100mV
 REC/PLAY DIN Socket ..30mV

TAPE-2 (4-CH ADAPTOR)
 REC Pin Jacks100mV

SWITCHES AND CONTROLS
 BASS ± 12 dB at 50Hz
 TREBLE ± 12 dB at 10,000Hz
 LOUDNESS+10dB at 50Hz
 +8dB at 10,000Hz
 LOW FILTER-10dB at 50Hz (6dB/oct.)
 HIGH FILTER-10dB at 10,000Hz
 (6dB/oct.)

TUNER SECTION

<FM>
 TUNING RANGE88 to 108MHz
 SENSITIVITY (IHF)2.0μV
 TOTAL HARMONIC DISTORTION
 MONO0.4%
 STEREO.....0.6%

SIGNAL TO NOISE RATIO ..better than 60dB

SELECTIVITYbetter than 60dB

CAPTURE RATIO2.0dB

IMAGE REJECTIONbetter than 75dB at 98MHz

IF REJECTIONbetter than 90dB at 98MHz

SUPURIOUS RESPONSE REJECTION
 better than 80dB at 98MHz

SPURIOUS RADIATIONless than 34dB

STEREO SEPARATIONbetter than 35dB at 400Hz

FREQUENCY RESPONSE30 to 12,000Hz ± 1.0 dB
 -3.0 dB

ANTENNA INPUT IMPEDANCE
 300Ω balanced, 75Ω unbalanced

<AM>
 TUNING RANGE535 to 1,605kHz
 SENSITIVITY (Bar Antenna) ..50dB/m at 1,000kHz

SELECTIVITYbetter than 28dB at 1,000kHz

IMAGE FREQUENCY REJECTION
 better than 80dB/m at 1,000kHz

IF REJECTIONbetter than 80dB/m at 1,000kHz

OTHERS

SEMICONDUCTORS
 TRANSISTORS49
 DIODES25
 FETs3
 ICs.....3
 ZENER DIODES4

POWER REQUIREMENTS
 VOLTAGE100, 117, 220, 240V, 50/60Hz
 CONSUMPTION100W (rated), 310VA (max.)

DIMENSIONS480mm (18- $\frac{7}{8}$ ") W
 135mm (5- $\frac{3}{8}$ ") H
 300mm (11- $\frac{13}{16}$ ") D

WEIGHT12.0kg (26.4 lbs.) net,
 14.6kg (32.7 lbs.) packed

* Design and specifications subject to change without notice for improvements.

2. BLOCK DIAGRAM AND LEVEL DIAGRAM

2-1. Block Diagram

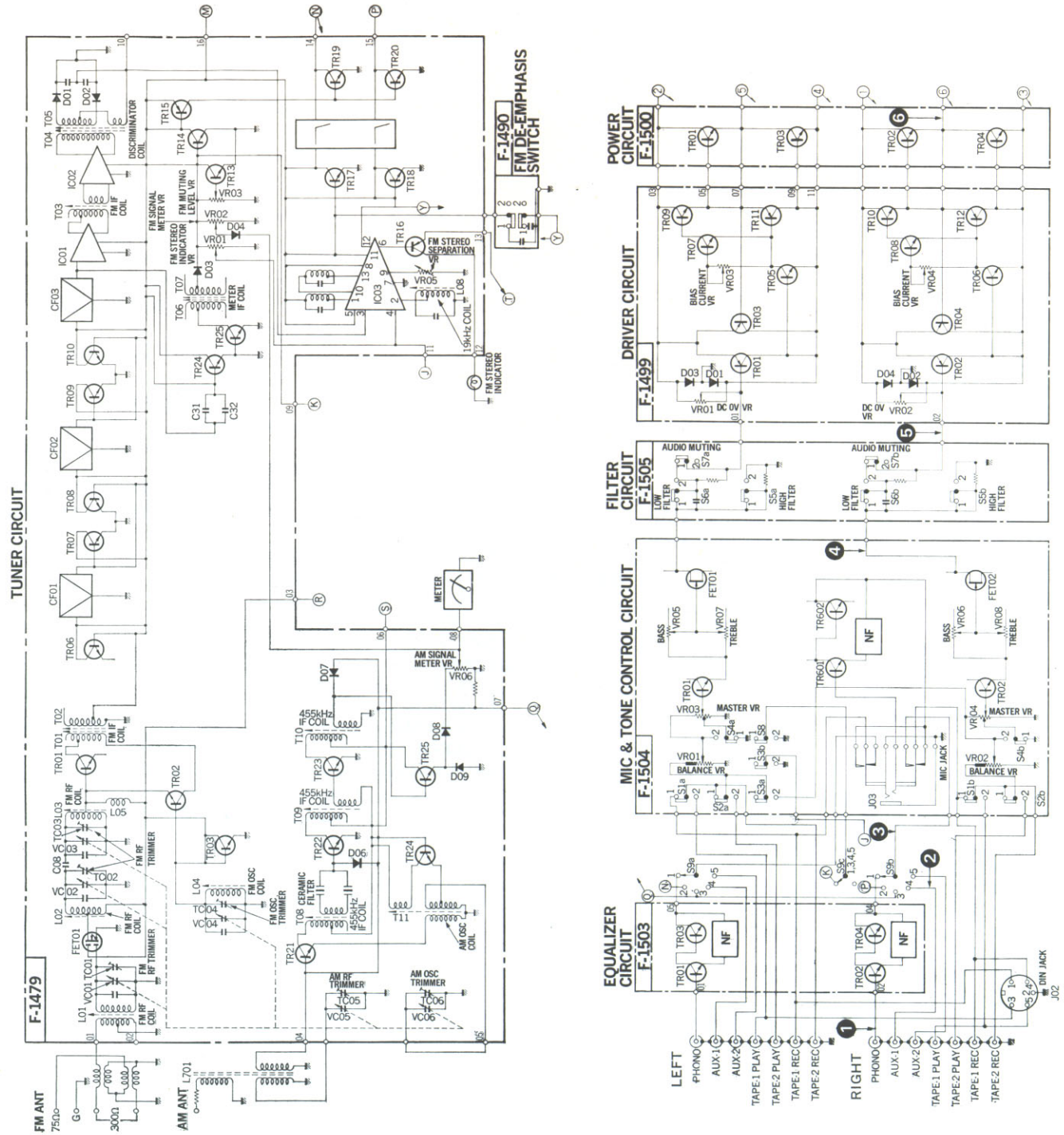

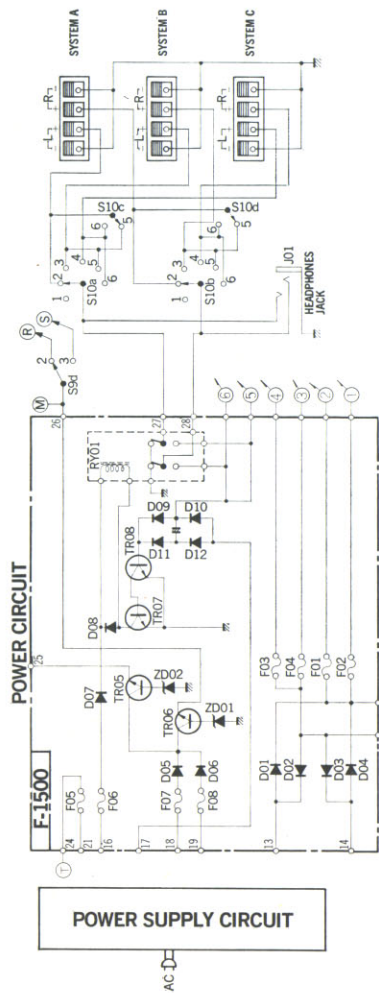

- S01: TAPE MONITOR-1
1. OFF
2. ON
- S02: TAPE MONITOR-2
1. OFF
2. ON
- S03: MONO
1. STEREO
2. MONO
- S04: LOUDNESS
1. OFF
2. ON
- S05: HIGH FILTER
1. OFF
2. ON
- S06: LOW FILTER
1. ON
2. OFF
- S07: AUDIO MUTING
1. OFF
2. ON
- S08: FM MUTING
1. OFF
2. ON
- S09: SELECTOR
1. PHONO
2. FM
3. AM
4. AUX-1
5. AUX-2
- S10: SP SELECTOR
1. OFF
2. A
3. B
4. C
5. A+B
6. A+C
- S11: POWER
1. OFF
2. ON
- S12: DE-EMPHASIS
1. 50 μ S
2. 75 μ S

2-2. Level Diagram

* Each number (①, ②, ③....) indicated in Level Diagram undermentioned corresponds to the number in Block Diagram.

1. MASTER VOLUME controlMaximum
2. BASS, TREBLE, BALANCE volume controlCenter
3. InputPHONO 2.5mV 1kHz Sine Wave
AUX-1 100mV 1kHz Sine Wave
(output impedance of 600 Ω at an audio oscillator)
4. Output19V (45W) 8 Ω

Note: Each voltage value is for reference and measured by a VTVM. In some recorders, the actual voltage value is in minor difference from the reference value.

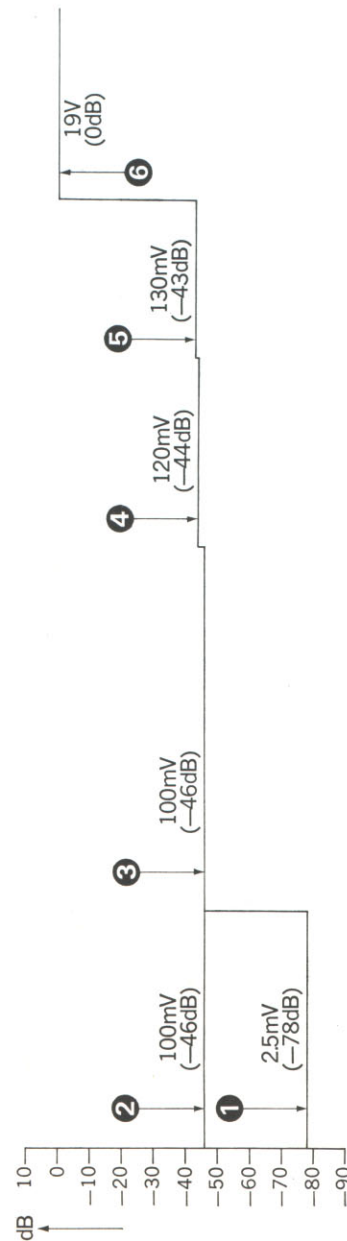

3. THREADING OF DIAL CORD

If dial cord is cut or slips, replace cord by following procedures. As 771 is used 0.6mmφ cord, please replace it with same type certainly.

* Length of dial cord..... approx. 150cm (59 inch)

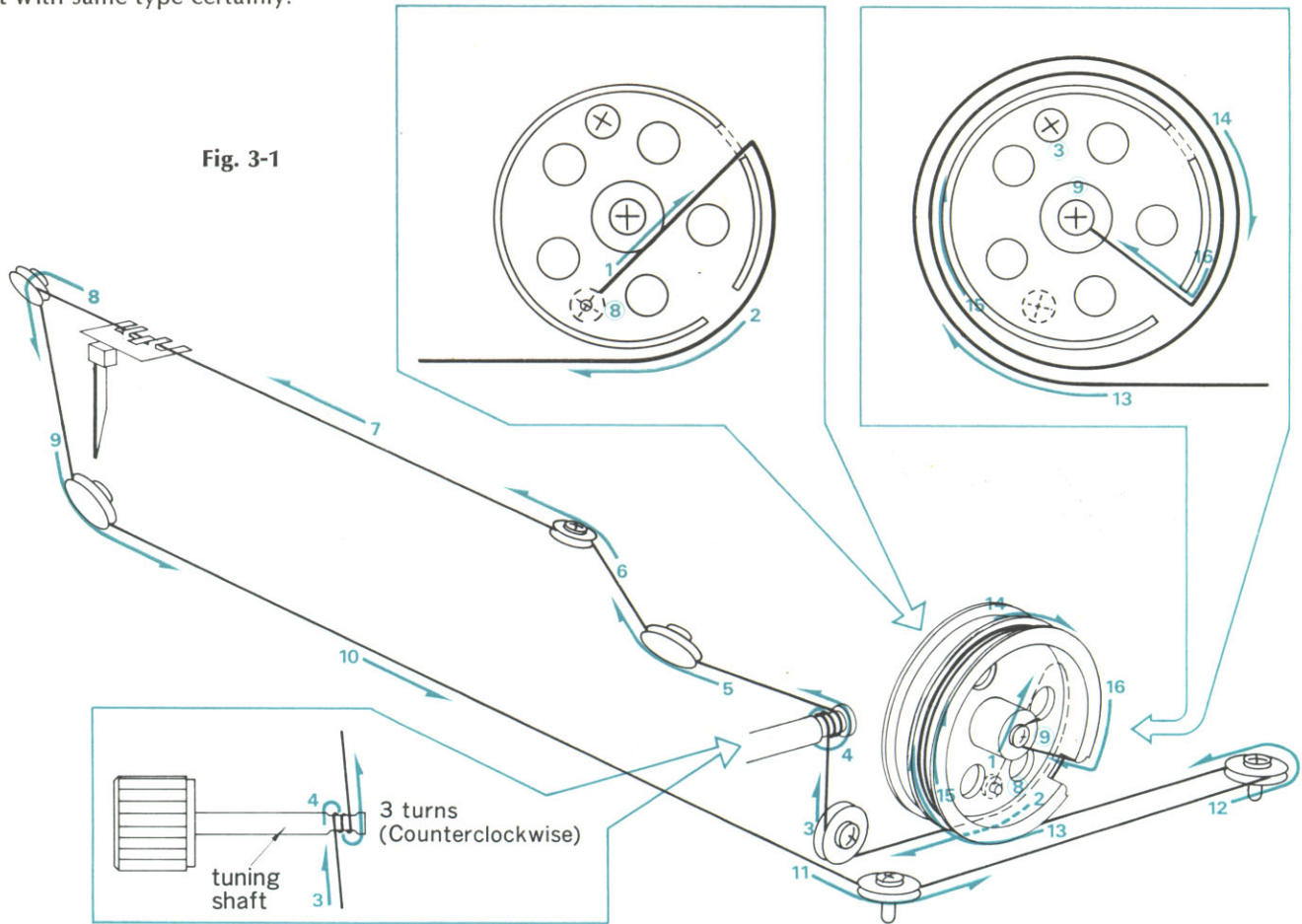

Fig. 3-1

1. Threading of Dial Cord

Thread dial cord in numerical order from 1 to 16 as shown in Fig. 3-1.

- 1) Close the variable capacitor completely (Max. capacitance) and tie cord to number ⑧ screw of the dial pulley.
- 2) Thread cord in the direction of arrow from 1 to 3, then wind cord three turns around the tuning shaft counterclockwise.
- 3) Thread cord in the direction of arrow from 4 to 12, then wind it two turns on the dial pulley from 13 to 16.
- 4) After 16, tie cord to number ⑨ screw of the dial pulley.

* When you perform procedure 4) successfully, please refer to the followings.

- ① To strengthen the dial cord tension, hold around the end of cord and pull it toward the Front Panel.
- ② Then, turn tuning shaft counterclockwise, as the cord tension will be more constantly obtained.
- ③ Tie the cord to number ⑨ screw of the dial pulley (same as procedure 4)).
- 5) After procedures, lock the knots of cord with paint.

2. Attachment of Dial Pointer

- 1) Close the variable capacitor completely.
- 2) Set the dial pointer to "0" on dial scale and install the dial pointer ass'y (See Fig. 3-2).

Fig. 3-2

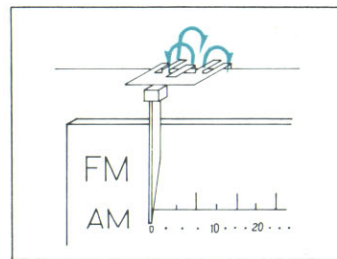

Stock No.	Description
6036050	Dial Cord (0.6mmφ)

4. ALIGNMENTS AND ADJUSTMENTS

Abbreviation

Equipment

AM FM Generator Oscilloscope.....Genescope
 AM Standard Signal GeneratorAM SSG
 FM Standard Signal GeneratorFM SSG
 FM Stereo Generator.....Stereo SG
 OscilloscopeScope
 Audio OscillatorAudio Osci.
 Distortion MeterDist. Meter

Others

ClockwiseCW.
 CounterclockwiseCCW.
 AntennaANT.
 Modulation.....MOD.

4-1. Driver Circuit Board Adjustment (See Figs. 4-1, 4-2 and 4-3)

- Note:** 1. Master Volume.....Minimum
 2. Speaker SelectorSYSTEM (A)
 3. Make the SP terminals free (no load).
 4. Confirm the AC Power Supply voltage.
 5. After adjustment, run the unit for more than 5 minutes, then check and readjust necessary.
 6. Room temperature should be 18~28° (65~83°F) for bias current adjustment.

STEP	SUBJECT	EQUIPMENT	MEASURE OUTPUT	ADJUST	ADJUST FOR	CONDITION
1	DC 0V L-ch	DC volt meter	Speaker terminal L-ch (Fig. 4-1)	F-1499 VR01	0V ±10mV	○ Step down meter's range accordingly ○ Change lead's polarity if meter swings backward
2	DC 0V R-ch	Same as above	Speaker terminal R-ch (Fig. 4-1)	F-1499 VR02	Same as above	Same as above
3	Bias current L-ch	DC milliammeter	F-1500 F01 (Fig. 4-2)	F-1499 VR03	19±1mA	○ Step down meter's range accordingly
4	Bias current R-ch	Same as above	F-1500 F02 (Fig. 4-2)	F-1499 VR04	Same as above	Same as above

Fig. 4-1

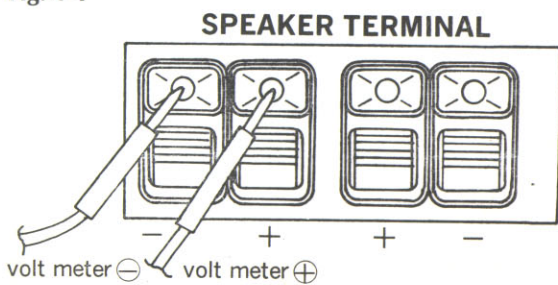

Fig. 4-2

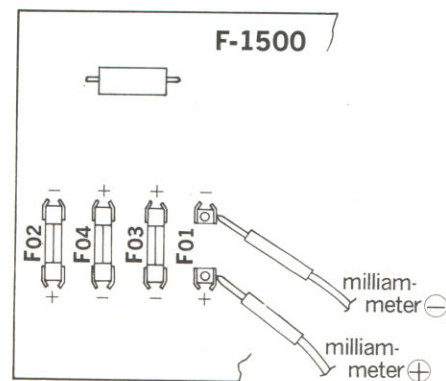
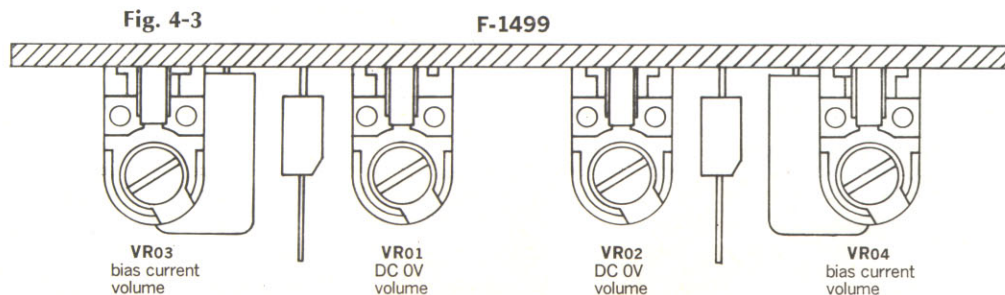

Fig. 4-3



4-2. FM IF Alignment (See Figs. 4-8 and 4-9 on page 10)

- Note:** 1. Selector.....FM AUTO
 2. Master VolumeMinimum
 3. Output level of genescopeAfter attenuator
 4. Sweepwidth.....1.5~2cm/150kHz
 5. Frequency band9.5~11.5MHz

6. ConnectionConnect the output of genescope to TP.A through 100p ceramic capacitor.
 7. Before adjustment, turn both VR01 and VR02 CCW (Max.), VR03 CW (Max.) and VR04 to center.

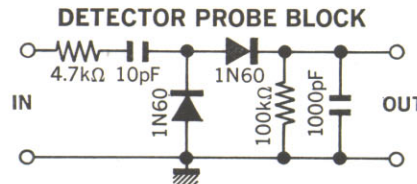
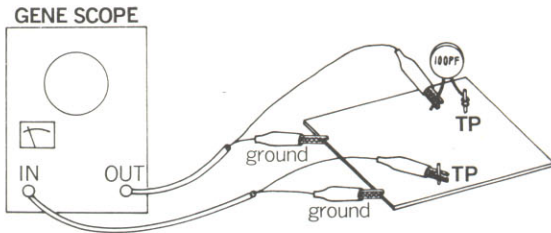



STEP	SUBJECT	FEED SIGNAL		MEASURE OUTPUT	ADJUST	ADJUST FOR	CONDITION
		FROM	TO				
1	IF coil	Output 55dB Genescope	Base of TR01 on F-1479 (Fig. 4-9 TP.A)	Connected Point between R48 & R50 on F-1479 (Fig. 4-9 TP.B) Use Detector Probe	T01, T02	Max. IF waveform 1 as Fig. 4-8	◦ Turn core of T06 CCW.
2	Meter coil	Same as above	Same as above	Connected point between R62 & VR02 on F-1479 (Fig. 4-9 TP.D) Direct from Genescope	T06, T07	Max. IF waveform 2 Set the center of waveform 2 with waveform 1 as Fig. 4-8	
3	Discriminator coil	Same as above	Same as above	Connected point between R67 & R68 on F-1479 (Fig. 4-9 TP.C) Direct from Genescope	T04 T05	Max. linearity of S curve Set the center of S curve waveform 1 & 2 as Fig. 4-8	
4	IF coil	Same as above	Same as above	Same as above	T03	Max. noise	

4-3. FM Dial Calibration and RF Alignment (See Fig. 4-9 on page 10)

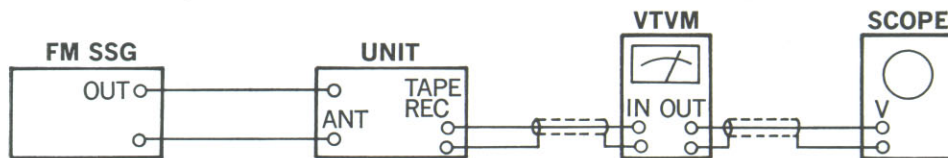
- Note:** 1. Selector.....FM AUTO
 2. Master VolumeMinimum
 3. FM Muting switchOFF (pushed in)
 4. Confirm start point of dial pointer before alignment.
 5. In Step 3, 4 and 5, 1 and 2 are readjusted, repeat 3, 4 and 5 again.

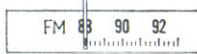

STEP	SUBJECT	FEED SIGNAL		MEASURE OUTPUT	ADJUST	ADJUST FOR	CONDITION
		FROM	TO				
1	88MHz Dial Calibration	88MHz ANT input 60dB 1kHz (100% MOD) FM SSG	ANT terminal 300Ω	REC OUT L or R-ch VTVM & Scope	L04	Max. output	◦ Set Dial on 88MHz 
2	108MHz Dial Calibration	108MHz ANT input 60dB 1kHz (100% MOD) FM SSG	Same as above	Same as above	Trimmer TC04	Same as above	◦ Set Dial on 108MHz 

STEP	SUBJECT	FEED SIGNAL		MEASURE OUTPUT	ADJUST	ADJUST FOR	CONDITION
		FROM	TO				
3	Confirm 88MHz Dial Calibration	Same as Step 1		Same as above		Confirm 88MHz Dial Calibration	◦ If not, repeat from Step 1
4	Confirm 98MHz Dial Calibration	98MHz ANT input 60dB 1kHz (100% MOD) FM SSG	Same as above	Same as above		Confirm 98MHz Dial Calibration	
5	Confirm 108MHz Dial Calibration	Same as Step 2		Same as above		Confirm 108MHz Dial Calibration	◦ If not, repeat from Step 2
6	88MHz RF Adj.	88MHz ANT input 10dB 1kHz (100% MOD) FM SSG	Same as above	Same as above	L01, L02, L03	Max. output	◦ Tune FM SSG (Max. indication of Signal Meter)
7	108MHz RF Adj.	108MHz ANT input 10dB 1kHz (100% MOD) FM SSG	Same as above	Same as above	Trimmer TC01, TC02, TC03	Same as above	Same as above

4-4. FM Signal Meter, Mono Distortion and Muting Adjustment (See Fig. 4-9 on page 10)

- Note:** 1. Selector.....FM AUTO
2. Master VolumeMinimum

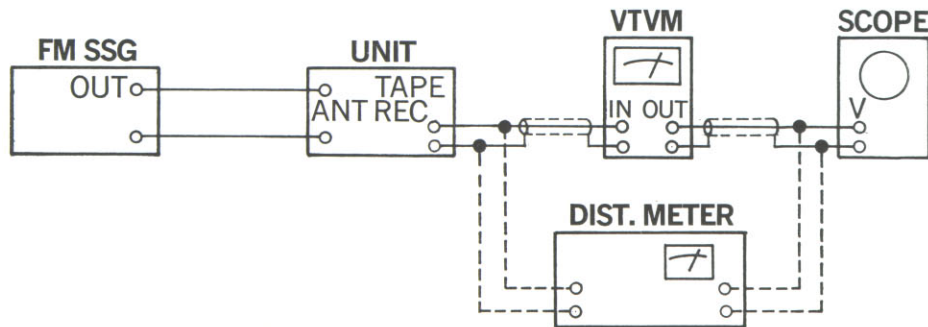

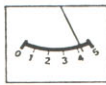
STEP	SUBJECT	FEED SIGNAL		MEASURE OUTPUT	ADJUST	ADJUST FOR	CONDITION
		FROM	TO				
1	Signal Meter	98MHz ANT input 66dB 1kHz (100% MOD) FM SSG	ANT terminal 300Ω	Signal Meter	VR02	4.3 on meter 	◦ Tune FM SSG (Max. indication of Signal Meter) ◦ Before adjustment, if meter swings out or not enough, preadjust VR02 until the reasonable point
2	Distortion	Same as above		REC OUT L or R-ch Dist. meter & Scope	T05	Min. distortion	◦ Tune FM SSG (Max. indication of signal meter)
3	Muting Level	98MHz ANT input 24dB 1kHz (100% MOD) FM SSG	Same as above	REC OUT L or R-ch VTVM & Scope	VR03	Audio signal just muted	◦ Set FM MUTING switch to OFF (pushed in)

4-5. MPX Alignment (See Fig. 4-9 on page 10)

- Note:** 1. SelectorFM AUTO
 2. Master Volume.....Minimum
 3. FM MUTING switchOFF (pushed in)
 4. Before adjustment, turn VR01 CW (Max.) and VR05 to center.

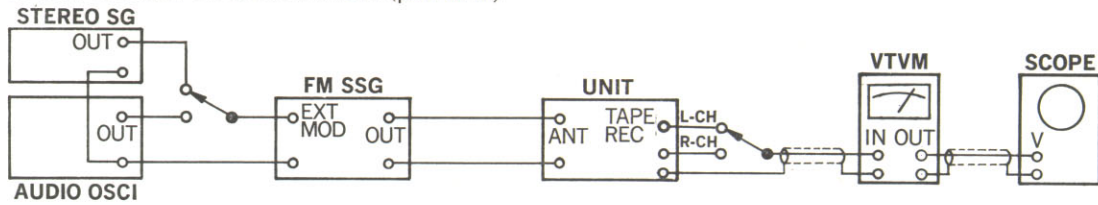

STEP	SUBJECT	FEED SIGNAL		MEASURE OUTPUT	ADJUST	ADJUST FOR	CONDITION
		FROM	TO				
1	19kHz coil	98MHz ANT input 60dB FM SSG Pilot 19kHz (10% MOD) L-ch 1kHz (45% MOD) R-ch (0% MOD) Stereo SG	ANT terminal 300Ω	REC OUT L-ch VTVM & Scope	L08	Max. output	o Tune FM SSG (Max. indication of signal meter)
2	Separation	Same as above	Same as above	REC OUT R-ch VTVM & Scope	VR05	Min. output	
3	Cofirm Separation	98MHz ANT input 60dB FM SSG Pilot 19kHz (10% MOD) L-ch (0% MOD) R-ch 1kHz (45% MOD) Stereo SG	Same as above	REC OUT L-ch VTVM & Scope		Min. output	o If less the 37dB adjust VR05
4	Indicator (Lighting level)	98MHz ANT input 39dB FM SSG Pilot 19kHz (10% MOD) Stereo SG	Same as above	Stereo indicator lamp	VR01	Lighting Point	o Tune FM SSG (Max. indication of signal meter)

4-6. AM IF, Dial Calibration, RF and Signal Meter Alignment (See Figs. 4-5, 4-6, 4-7 and 4-9 on page 10)

- Note:** 1. Selector.....AM
 2. Master VolumeMinimum
 3. Confirm start point of dial pointer before alignment.
 4. In case of using loop antenna, increase output of AM SSG for 26dB than bar antenna's direct input as it attenuates input sensitivity for 26dB (See Fig. 4-4).
 5. After adjustment of signal meter, confirm the meter's swing on FM. (If meter swings out or not enough, readjust VR02.) (See Page 8)

Fig. 4-4

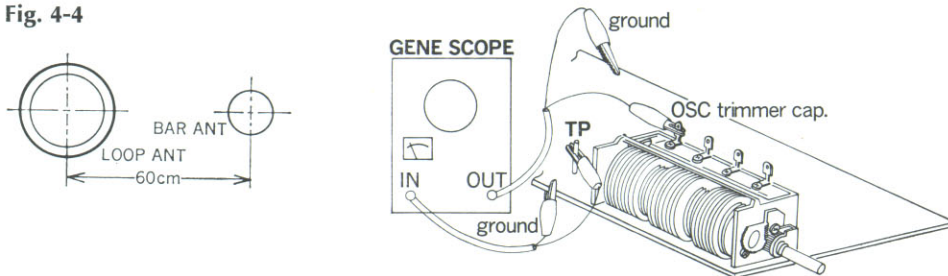

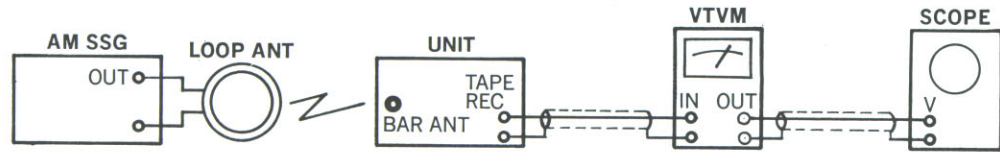



STEP	SUBJECT	FEED SIGNAL		MEASURE OUTPUT	ADJUST	ADJUST FOR	CONDITION
		FROM	TO				
1	IF coil	Output 70dB Genescope	OSC trimmer cap. (TC06) Fig. 4-9	Connected Point between R130 & R136 on F-1479 (Fig. 4-9 TP.E)	T08	Max. IF wave- form 1 Fig. 4-5	○ Turn core T09 & T10 CCW.
2	IF coil	Output 55dB Genescope	Same as above		T09	Max. IF wave- form 2 Fig. 4-6	
3	IF coil	Output 45dB Genescope	Same as above		T10	Max. IF wave- form 3 Fig. 4-7	○ If not, readjust T08 & T09 slightly
4	535kHz Dial calibration	535kHz ANT input 60dB 400Hz (30% MOD) AM SSG Use loop ANT	Bar ANT	REC OUT L or R-ch VTVM & Scope	T11	Max. output	○ If broadcasting station is near, it might be used
5	1400kHz Dial Calibration	1400kHz ANT input 60dB 400Hz (30% MOD) AM SSG Use loop ANT	Same as above	Same as above	Trimmer TC06	Same as above	Same as above 
6	Confirm 600kHz Dial Calibration	600kHz ANT input 60dB 400Hz (30% MOD) AM SSG Use loop ANT	Same as above	Same as above		Confirm 600kHz Dial Calibration	○ If not, repeat from Step 4
7	Confirm 1000kHz Dial Calibration	1000kHz ANT input 60dB 400Hz (30% MOD) AM SSG Use loop ANT	Same as above	Same as above		Confirm 1000kHz Dial Calibration	
8	Confirm 1400kHz Dial Calibration	Same as Step 5	Same as above	Same as above		Confirm 1400kHz Dial Calibration	○ If not, repeat from Step 5
9	600kHz RF Adj.	600kHz ANT input 50dB 400Hz (30% MOD) AM SSG Use loop ANT	Same as above	Same as above	Bar ANT L701	Max. output	
10	1400kHz RF Adj.	1400kHz ANT input 50dB 400Hz (30% MOD) AM SSG Use loop ANT	Same as above	Same as above	Trimmer TC05	Same as above	
11	Signal Meter	1000kHz ANT input 100dB 400Hz (30% MOD) AM SSG Use loop ANT	Same as above	Same as above	F-1479 VR06	4 on meter 	○ Tune AM SSG (Max. indication of signal meter) ○ Before adjustment, if meter swang out or not enough, preadjust VR06 until the reason- able point

Fig. 4-5

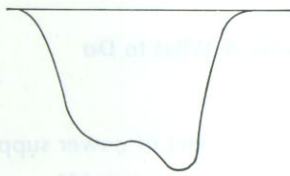

Fig. 4-6

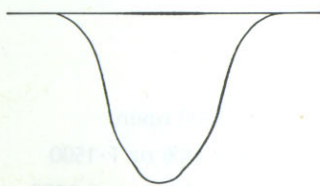

Fig. 4-7

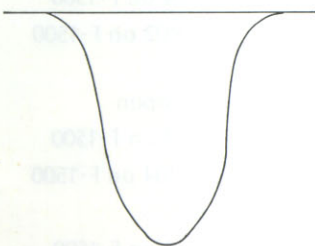

Fig. 4-8

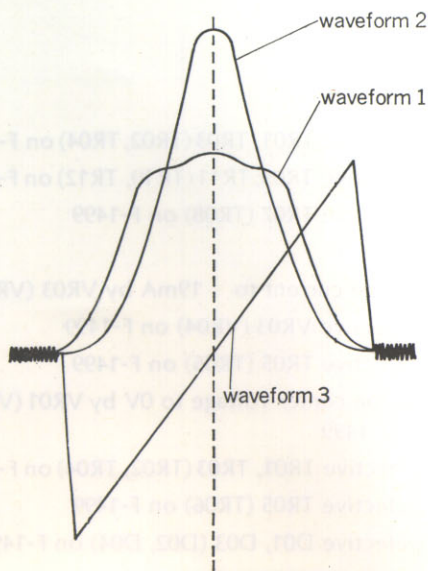
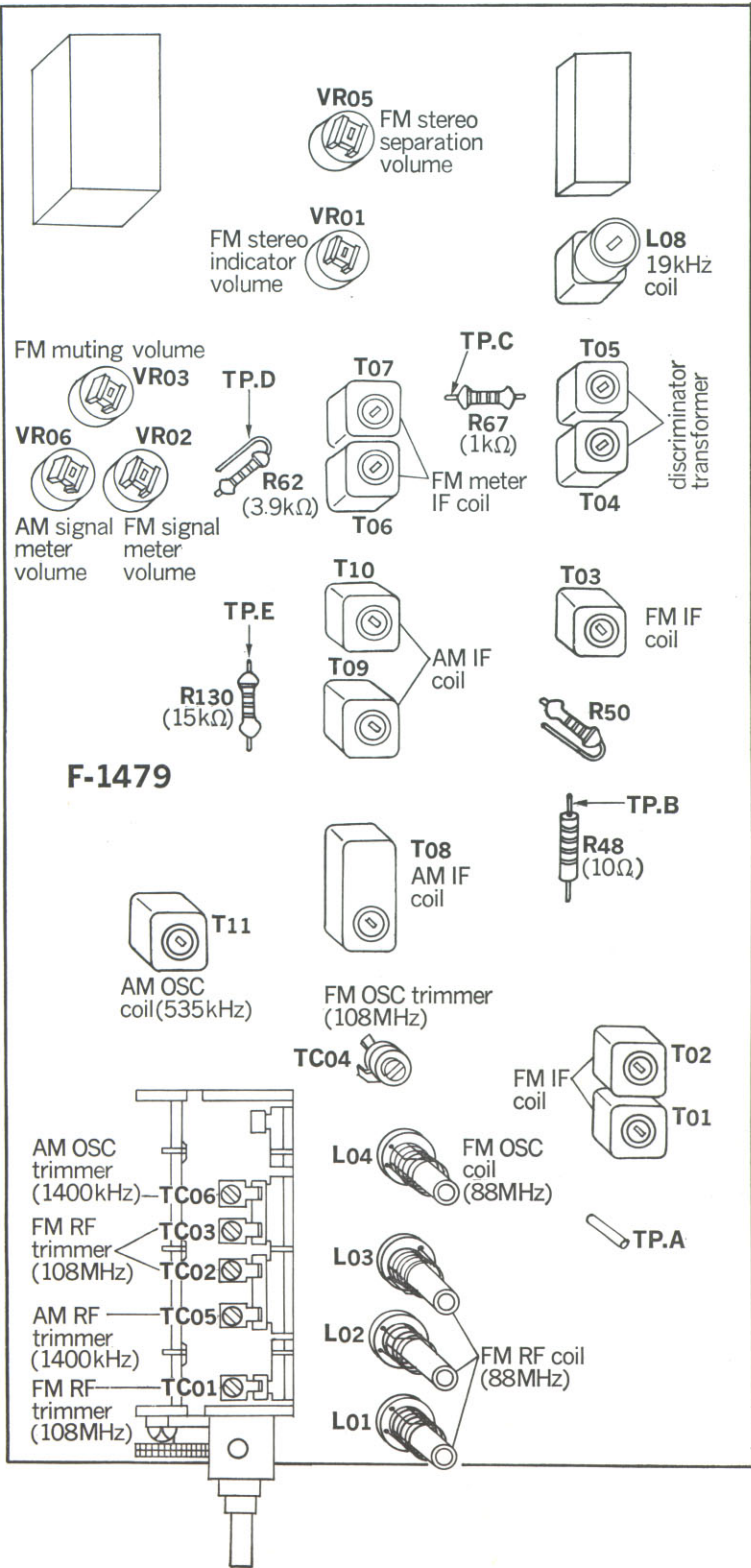

Fig. 4-9



5. TROUBLESHOOTING CHART

5-1. Troubleshooting on Power Supply Section

Symptom	Check Point	Cause & What to Do
1. No power supplied to each section		
1-1. Each lamp not lighted		1. Imperfect contact of power supply plug 2. Defective power switch S11 3. Imperfect contact of voltage selector 4. Power fuse F701 open 5. F05 on F-1500 open 6. Defective power transformer
1-2. Each lamp lighted		
	1) +33V not supplied to emitter of TR05 and +13.6V not supplied to emitter of TR06 on F-1500	7. F07, F08 on F-1500 open 8. Defective D05, D06 on F-1500 9. Defective TR05, TR06 on F-1500 10. Defective ZD01, ZD02 on F-1500
	2) +35V not supplied to terminal (03) (04) on F-1499	11. F01, F02 on F-1500 open 12. Defective D01, D04 on F-1500 13. Defective TR01, TR02 on F-1500
	3) -35V not supplied to terminal (11) (12) on F-1499	14. F03, F04 on F-1500 open 15. Defective D02, D03 on F-1500 16. Defective TR03, TR04 on F-1500
	4) Normal voltages supplied to each terminal on F-1500	17. F06 on F-1500 open 18. Defective D07, D08 on F-1500 19. Defective TR07, TR08 on F-1500 20. Defective Relay RY101 on F-1500

5-2. Troubleshooting on Audio Section

1. Quick acting fuse open

1-1. After replacement, fuse open again		1. Defective TR01, TR03 (TR02, TR04) on F-1500 2. Defective TR09, TR11 (TR10, TR12) on F-1499 3. Defective TR07 (TR08) on F-1499
1-2. After replacement, fuse not open		
	1) DC Bias current adjustable	4. Set the current to +19mA by VR03 (VR04)
	2) DC Bias current not adjustable	5. Defective VR03 (VR04) on F-1499 6. Defective TR05 (TR06) on F-1499
	3) Center voltage adjustable	7. Set the center voltage to 0V by VR01 (VR02) on F-1499
	4) Center voltage not adjustable	8. Defective TR01, TR03 (TR02, TR04) on F-1499 9. Defective TR05 (TR06) on F-1499 10. Defective D01, D03 (D02, D04) on F-1499 11. Defective VR01 (VR02) on F-1499

2. AUX inoperative

Symptom	Check Point	Cause & What to Do
2-1. Both channels inoperative		12. Defective power supply section (F-1500)
2-2. One channel inoperative		
1) L and R-ch will be operative when MONO switch is pushed in (It's MONO position)		13. Imperfect contact of SELECTOR switch S9a (S9b)
2) One channel will be inoperative when MONO switch is push in		14. Defective TR01, FET01 (TR02, FET02) on F-1504
		15. Imperfect contact of TAPE MONITOR switch S1, S2, MONO switch S3
		16. Defective BALANCE volume VR01
		17. Imperfect contact of SELECTOR switch S9a (S9b)
		18. Imperfect contact of SP SELECTOR switch S10a, S10b
		19. Defective F-1499
3. MIC inoperative		20. Defective power supply section (F-1500)
		21. Defective TR601, TR602 on F-1504
		22. Imperfect contact of MIC jack

4. PHONO inoperative

4-1. Both channels inoperative		23. Defective power supply section (F-1500)
4-2. One channel inoperative		
1) Reverse the output cords of L and R-ch from turntable		
1-1) Inoperative channel reverse		24. Imperfect contact of the output cord
		25. Defective turntable
1-2) Inoperative channel not reverse		26. Defective TR01, TR03 (TR02, TR04) on F-1503
		27. Imperfect contact of SELECTOR switch S9a (S9b)

5-3. Troubleshooting on Tuner Section

1. Both FM and AM inoperative (PHONO operative)

1-1. Both channels inoperative		
1) 13.6V not supplied to terminal 03, 06, 16 on F-1479		1. Defective power supply section (F-1500)
2) 13.6V not supplied to terminal 03, 06, on F-1479		2. Imperfect contact of SELECTOR switch S9c
1-2. One channel inoperative		
1) AM section inoperative		3. Defective SELECTOR switch S9a (S9b)
2) FM section inoperative		4. Defective SELECTOR switch S9a (S9b)
		5. Defective TR17 (TR18) on F-1479
		6. Defective Low Pass Filter L.P.F. 11

2. FM Section

*Before check, set MUTING switch to OFF (Pushed in)

2-1. FM inoperative only		
1) Tune FM signal or FM broadcasting station		
1-1) Signal meter operative (Interstation noise too low compared with proper unit)		7. Defective IC01, IC02 on F-1479
		8. Defective T01~T05 on F-1479
		9. Defective D01, D02 on F-1479
		10. Defective IC03 on F-1479

*to page 12

Symptom	Check Point	Cause & What to Do
*from page 11		
	1-2) Signal meter inoperative	11. Defective CF01~CF03 on F-1479 12. Defective FET01, TR01, TR02 on F-1479 13. Defective TR05~TR10 on F-1479 14. Defective L01~L03 on F-1479 15. Defective T01~T05 on F-1479
2-2. Signal meter inoperative (FM broadcasting sound can be heard)		16. IF, RF out of adjustment on F-479 17. Defective TR11, TR12 on F-1479 18. Defective T06, T07 on F-1479 19. Defective D03, D04 on F-1479 20. Defective VR02 on F-1479 21. Defective signal meter
2-3. Muting circuit inoperative (Signal meter operative)		22. Defective TR13~TR15 on F-1479 23. Defective TR19, TR20 on F-1479 24. Defective D05 on F-1479 25. Defective VR03 on F-1479 26. Imperfect contact of MUTING switch S8
2-4. No channel separation on FM stereo broadcasting *Confirm that SELECTOR switch is set to FM AUTO *Confirm signal meter operates		
	1) Indicator lamp not lighted	27. Defective the indicator lamp PL726 28. Defective TR16 on F-1479 29. Defective L08 on F-1479 30. Defective IC03 on F-1479 31. Defective VR01 for indicator lamp on F-1479 32. Defective VR05 for FM stereo separation on F-1479
	2) Indicator lamp lighted	33. Defective F-1500 34. Defective TR16 on F-1479

3. AM Section

3-1. AM inoperative		
	1) Interstation noise changes by touching the terminal 04 on F-1479	
	1-1) Increase	35. Defective bar antenna 36. Defective TR24 on F-1479 37. Defective T11 on F-1479 38. Variable capacitor shorted
	1-2) No change	39. Defective D07 on F-1479 40. Defective TR21~TR23 on F-1479 41. Defective T08~T10 on F-1479
3-2. Distortion		42. Defective D06, D07 on F-1479 43. IF out of adjustment on F-1479
3-3. Signal meter inoperative (AM broadcasting sound can be heard)		44. IF, RF out of adjustment on F-1479 45. Defective TR25 on F-1479 46. Defective D08, D09 on F-1479 47. Imperfect contact of VR06 on F-1479 48. Defective signal meter

6. PARTS LOCATIONS AND PARTS LIST

6-1. F-1479D Tuner Circuit Board (Stock No. 7520710 Complete Circuit Board F-1479D)

Parts List

Parts No.	Stock No.	Description	Position	Parts No.	Stock No.	Description	Position
TR01	0305801	2SC1047 (B)	1 A	L04	4220530	OSC Coil	1 A, B
TR02	0305802	2SC1047 (C)	1 A	L05	4290110	Choke Coil	1 A
TR03	0305790, 1	2SC930 (C,D)	1 B	L06	4290011	3.5μH Choke Coil	
TR06	0306113	2SC738 (D)	1 B	L07	4290011	3.5μH Choke Coil	1 D
TR07	0306113	2SC738 (D)	1 B, C	L08	4240720	19kHz Coil	1 E
TR08	0306113	2SC738 (D)	1 B, C	LC01	4240710	MPX Coil	1 E
TR09	0306112	2SC738 (C)	1 C	LPF01	0910210	Low Pass Filter	2 E
TR10	0306112	2SC738 (C)	1 C	VC01~04	1220130	Variable Capacitor	2 A, B
TR11	0305791	2SC930 (D)	1 C	C01	0669368	6.8pF ±0.25pF 50V	C.C. 2 A
TR12	0305791	2SC930 (D)	1, 2 C	C02	0657102	0.001 μF 50V	C.C. 1 A
TR13	0305733	2SC711 (G)	2 D	C03	0659015	2200pF	1 A
TR14	0305733	2SC711 (G)	2 D	C04	0659015	2200pF	1 A
TR15	0300291, 2	2SA678 (6, 7)	2 D	C05	0659015	2200pF	50V C.C. 1 A
TR16	0300221	2SA562 (Y)	2 D	C06	0659015	2200pF	1 A
TR17	0306141	2SC1362⑤ (7)	1 E	C07	0669370	10pF ±5pF 50V	C.C. 1, 2 A
TR18	0306141	2SC1362⑤ (7)	2 E	C08	0679023	0.39pF ±5% 50V	C.C.
TR19	0306131, 2	2SC1364 (6, 7)	2 E	C09	0669370	10pF ±5pF 50V	C.C. 2 A
TR20	0306131, 2	2SC1364 (6, 7)	2 E	C10	0669212	12pF ±5% 50V	C.C. 1 A
TR21	0305992	2SC403C (4)	2 B	C11	0656223	0.022 μF 50V	C.C. 1 A
TR22	0305992	2SC403C (4)	2 C	C12	0660221	220pF ±10% 50V	C.C. 1 A
TR23	0305992	2SC403C (4)	2 C	C13	0669210	10pF ±5% 50V	C.C. 1 A
TR24	0305991	2SC403C (3)	2 B	C14	0669218	18pF ±5% 50V	C.C. 1 A
TR25	0305991	2SC403(3) C	2 C	C15	0657223	0.022 μF	1 A
IC01	0360070	μpc555A	1 C	C16	0657223	0.022 μF	±5% 50V C.C. 1 B
IC02	0360070	μpc555A	1 D	C17	0657223	0.022 μF	1 A
IC03	0360080	HA1120	1 E	C18	0669210	10pF ±5% 50V	C.C. 1 A, B
FET ₁₀₁	0370132	3SK41K (1)	FET 1 A	C19	0669370	10pF ±0.25pF 50V	C.C. 1 B
D01	0311060	1N60P	1 D, E	C20	0669382	12pF ±5% 50V	2 B
D02	0311060	1N60P	1 D, E	C21	0669369	8.2pF ±0.25pF 50V	C.C. 1 B
D03	0310331	1N60	2 D	C22	0657223	0.022 μF 50V	1 B
D04	0340090	DS430	2 D	C23	0669375	15pF ±5% 50V	1 B
D05	0340090	DS430	2 D	C26	0657223	0.022 μF	1 B
D06	0310331	1N60	2 B	C27	0657223	0.022 μF	1 B
D07	0311090	1S1007-J	1, 2 C	C28	0657223	0.022 μF	1 C
D08	0310331	1N60	2 C	C29	0657223	0.022 μF	1 C
D09	0310331	1N60	2 C	C30	0657223	0.022 μF	1 C
T01	4235890	10.7MHz (WHITE)	1 A, B	C31	0669218	18pF	1 C
T02	4235900	10.7MHz (BLACK)	1 B	C32	0669224	33pF	1 C
T03	4235860	10.7MHz (BLACK)	1 D	C33	0657223	0.022 μF	1 C
T04	4235750	10.7MHz (PINK)	1 D	C34	0657223	0.022 μF	1 D
T05	4235760	10.7MHz (BLUE)	1 D	C35	0657223	0.022 μF	1 C
T06	4235840	10.7MHz (BLUE)	1, 2 D	C36	0657223	0.022 μF	2 C
T07	4235920	10.7MHz (BLACK)	1, 2 D	C37	0657223	0.022 μF	50V C.C. 1 D
T08	0910180	YEL-455E2 (CFW-455B)	1, 2 B	C38	0657223	0.022 μF	2 D
T09	4230610	455kHz (BLACK)	1, 2 C	C39	0657223	0.022 μF	1 D
T10	4230580	455kHz (BLUE)	1, 2 C	C40	0657223	0.022 μF	1 D
T11	4220380	AM OSC Coil	2 B	C41	0657223	0.022 μF	1 D
CF01	0910150	SFE-10.7MA-M	1 B	C42	0669226	47pF	2 D
CF02	0910150	SFE-10.7MA-M	1 C	C43	0657223	0.022 μF	1 D
CF03	0910150	SFE-10.7MA-M	1 C	C44	0657223	0.047 μF	1 D
L01	4200560	FM ANT Coil	1 A	C46	0657223	0.022 μF	2 D
L02	4210300	FM RF Coil	1, 2 A	C47	0657223	0.022 μF	2 D
L03	4210300	FM RF Coil	1 A	C48	0657223	0.022 μF	2 D
				C49	0573108	0.1 μF ±20% 25V	T.C. 2 D
				C50	0660101	100pF	±10% 50V C.C. 1 D
				C51	0660101	100pF	±10% 50V C.C. 1 D
				C52	0519001	10 μF	25V E.C. 1 D
				C53	0660101	100pF ±10% 50V	C.C. 1 D
				C54	0513479	4.7 μF	25V E.C. 2 D

Conductor Side

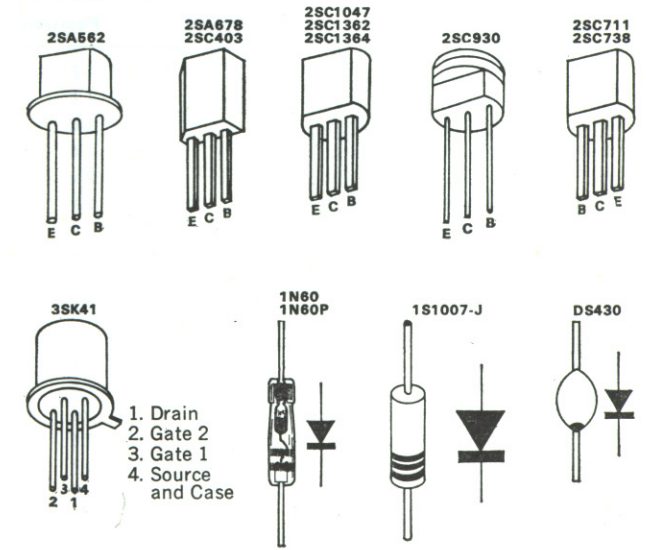
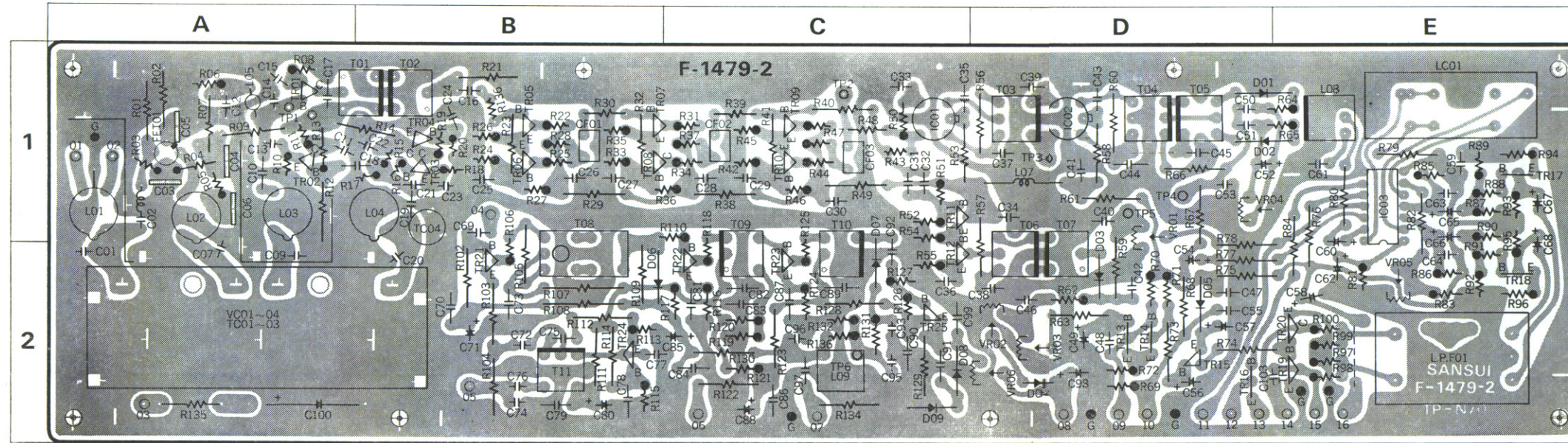

Parts No.	Stock No.	Description	Position
C55	0657223	0.022µF 50V C.C.	2 D
C56	0519104	1.5µF ±20% 50V E.C.	2 D
C57	0515339	3.3µF 50V E.C.	2 D
C58	0512221	220µF 16V E.C.	2 E
C59	0657223	0.022µF 50V C.C.	1 E
C60	0515339	3.3µF 50V E.C.	1 E
C61	0629001	6800pF ± 5% 50V P.C.	1 E
C62	0512100	10µF 16V E.C.	2 E
C63	0600187	0.018µF ± 5% 50V M.C.	1 E
C64	0600187	0.018µF ± 5% 50V M.C.	2 E
C65	0519105	2.2µF 1 E	1 E
C66	0519105	2.2µF ±20% 50V E.C.	1 E
C67	0519105	2.2µF 1 E	1 E
C68	0519105	2.2µF 1, 2 E	1, 2 E
C69	0657223	0.022µF 50V C.C.	1 B
C70	0657473	0.047µF ±20% 50V E.C.	2 B
C71	0519102	3.3µF ±20% 50V E.C.	2 B
C72	0601107	0.01µF 50V M.C.	2 B
C73	0657473	0.047µF 50V C.C.	2 B
C74	0669215	15pF 50V C.C.	2 B
C75	0601107	0.01µF 50V M.C.	2 B
C76	0620361	360pF ± 5% 50V P.C.	2 B
C77	0669223	27pF ± 5% 50V C.C.	2 B, C
C78	0657473	0.047µF 50V C.C.	2 B
C79	0657473	0.047µF 50V C.C.	2 B
C80	0512470	47µF 16V E.C.	2 B
C81	0657473	0.047µF 2 C	2 C
C82	0657473	0.047µF 50V C.C.	2 C
C83	0657473	0.047µF 2 C	2 C
C84	0657473	0.047µF 2 C	2 C
C85	0512100	10µF 16V E.C.	2 C
C86	0657473	0.047µF 50V C.C.	2 C
C87	0601108	0.1µF ±10% 50V M.C.	2 C
C88	0512470	47µF 16V E.C.	2 C
C89	0657473	0.047µF 2 C	2 C
C90	0657473	0.047µF 50V C.C.	2 C
C91	0657473	0.047µF 2 C	2 C

Parts No.	Stock No.	Description	Position
C92	0669226	47pF ± 5% 50V C.C.	1, 2 C
C93	0601476	0.0047µF ± 5% 50V M.C.	2 C
C95	0601476	0.0047µF ± 5% 50V M.C.	2 C
C96	0600107	0.01µF ± 5% 50V M.C.	2 C
C97	0601477	0.047µF ±10% 50V M.C.	2 C
C98	0510101	100µF 6.3V E.C.	2 D
C99	0657473	0.047µF 50V C.C.	2 C
C103	0620221	220pF ± 5% 50V P.C.	2 D, E
C104	0669215	15pF ± 5% 50V C.C.	2 D, E
C105	0657223	0.022µF 50V C.C.	2 D, E
C106	0601687	0.068µF 50V M.C.	2 D, E
R01	0107104	100kΩ ± 5% ¼W C.R.	1 A
R02	0107181	180Ω ± 5% ¼W C.R.	1 A
R03	0106104	100kΩ 1 A	1 A
R04	0106224	220kΩ ± 5% ¼W 1 A	1 A
R05	0106220	22Ω ± 5% ¼W C.R. (E.L.R.)	1 A
R06	0106222	2.2kΩ ± 5% ¼W C.R. (E.L.R.)	1 A
R08	0106102	1kΩ 1 A	1 A
R09	0107220	22Ω ± 5% ¼W C.R.	1 A
R10	0106221	220Ω ± 5% ¼W C.R.	1 A
R11	0106121	120Ω ± 5% ¼W C.R. (E.L.R.)	1 A
R12	0107682	6.8kΩ ± 5% ¼W C.R.	1 A
R13	0106473	47kΩ ± 5% ¼W C.R. (E.L.R.)	1 A
R14	0107102	1kΩ ± 5% ¼W C.R.	1 A, B
R15	0106152	1.5kΩ 1 B	1 B
R16	0106220	22Ω ± 5% ¼W C.R. (E.L.R.)	1 B
R17	0106222	2.2kΩ ± 5% ¼W C.R. (E.L.R.)	1 B
R18	0107122	1.2kΩ 1 B	1 B
R23	0107221	220Ω ± 5% ¼W C.R.	1 B
R24	0106152	1.5kΩ 1 B	1 B
R25	0106151	150Ω ± 5% ¼W C.R. (E.L.R.)	1 B
R27	0106183	18kΩ ± 5% ¼W C.R. (E.L.R.)	1 B
R28	0106471	470Ω 1 B	1 B
R29	0107479	4.7Ω ± 5% ¼W C.R.	1 B

Parts No.	Stock No.	Description	Position
R30	0106101	100Ω ± 5% ¼W S.R.	1 B
R31	0106151	150Ω ± 5% ¼W C.R. (E.L.R.)	1 C
R32	0107182	1.8kΩ ± 5% ¼W C.R.	1 B
R33	0106472	4.7kΩ ± 5% ¼W C.R.	1 B
R34	0106151	150Ω ± 5% ¼W C.R. (E.L.R.)	1 C
R35	0106221	220Ω ± 5% ¼W C.R. (E.L.R.)	1 B
R36	0106153	15kΩ ± 5% ¼W C.R. (E.L.R.)	1 B, C
R37	0106471	470Ω 1 C	1 C
R38	0107479	4.7Ω ± 5% ¼W C.R.	1 C
R39	0106101	100Ω ± 5% ¼W S.R.	1 C
R40	0106151	150Ω ± 5% ¼W C.R. (E.L.R.)	1 C
R41	0107182	1.8kΩ ± 5% ¼W C.R.	1 C
R42	0106472	4.7kΩ ± 5% ¼W C.R. (E.L.R.)	1 C
R43	0107222	2.2kΩ ± 5% ¼W C.R.	1 C
R44	0106151	150Ω 1 C	1 C
R45	0106221	220Ω 1 C	1 C
R46	0106153	15kΩ ± 5% ¼W C.R. (E.L.R.)	1 C
R47	0106471	470Ω 1 C	1 C
R48	0106100	10Ω 1 C	1 C
R49	0107479	4.7Ω ± 5% ¼W C.R.	1 C
R50	0106102	1kΩ ± 5% ¼W C.R. (E.L.R.)	1 C
R51	0106473	47kΩ ± 5% ¼W C.R. (E.L.R.)	1 C
R52	0106153	15kΩ 1 C	1 C
R53	0107100	10Ω ± 5% ¼W C.R.	1 C
R54	0106222	2.2kΩ ± 5% ¼W C.R. (E.L.R.)	1 C
R55	0106821	820Ω ± 5% ¼W C.R. (E.L.R.)	2 C
R56	0107103	10kΩ 1 D	1 D
R57	0107101	100Ω 1, 2 D	1, 2 D
R58	0107100	10Ω ± 5% ¼W C.R.	1 D
R59	0107103	10kΩ 1, 2 D	1, 2 D
R60	0107682	6.8kΩ 1 D	1 D
R61	0107479	4.7Ω 1 D	1 D
R62	0106392	3.9kΩ ± 5% ¼W C.R. (E.L.R.)	2 D
R63	0107683	68kΩ ± 5% ¼W C.R.	2 D

Parts No.	Stock No.	Description	Position
R64	0106102	1kΩ ± 5% ¼W C.R. (E.L.R.)	1 D, E
R65	0106102	1kΩ ± 5% ¼W C.R. (E.L.R.)	1 D, E
R66	0107100	10Ω 1 D	1 D
R67	0107102	1kΩ ± 5% ¼W C.R.	1, 2 D
R68	0107153	15kΩ 2 D	2 D
R69	0106152	1.5kΩ 2 D	2 D
R70	0106105	1MΩ ± 5% ¼W C.R. (E.L.R.)	2 D
R71	0106153	15kΩ ± 5% ¼W C.R. (E.L.R.)	2 D
R72	0106560	56Ω 2 D	2 D
R73	0107473	47kΩ 2 D	2 D
R74	0107472	4.7kΩ 2 D, E	2 D, E
R75	0107479	4.7Ω 2 D, E	2 D, E
R76	0107103	10kΩ ± 5% ¼W C.R.	1, 2 E
R77	0107100	10Ω ± 5% ¼W C.R.	2 D, E
R78	0107104	100kΩ 2 D, E	2 D, E
R79	0107151	150Ω 1 E	1 E
R80	0107479	4.7Ω 1 E	1 E
R81	0106472	4.7kΩ ± 5% ¼W C.R. (E.L.R.)	2 E
R82	0107151	150Ω ± 5% ¼W C.R. (E.L.R.)	1, 2 E
R83	0106561	560Ω ± 5% ¼W C.R. (E.L.R.)	2 E
R84	0107822	8.2kΩ ± 5% ¼W C.R.	1, 2 E
R85	0106332	3.3kΩ ± 5% ¼W C.R. (E.L.R.)	1 E
R86	0106332	3.3kΩ ± 5% ¼W C.R. (E.L.R.)	2 E

to be continued

Abbreviations

C.R. : Carbon Resistor	BP.E.C.: Bi-Pola Electrolytic Capacitor
S.R. : Solid Resistor	C.C. : Ceramic Capacitor
Ce.R. : Cement Resistor	Mi.C. : Mica Capacitor
M.R. : Metallized Film Resistor	O.C. : Oil Capacitor
M.C. : Mylar Capacitor	P.C. : Polystyrene Capacitor
E.C. : Electrolytic Capacitor	T.C. : Tantalum Capacitor

F-1479D Parts List

Parts No.	Stock No.	Description	Position
R87	0106184	180kΩ	1 E
R88	0106332	3.3kΩ	1 E
R89	0106273	27kΩ	1 E
R90	0106184	180kΩ	1 E
R91	0106332	3.3kΩ	2 E
R92	0106273	27kΩ	2 E
R93	0106332	3.3kΩ ± 5% 1/4W C.R. (E.L.R.)	1 E
R94	0106391	390Ω	1 E
R95	0106332	3.3kΩ	1, 2 E
R96	0106391	390Ω	2 E
R97	0106332	3.3kΩ	2 E
R98	0106562	5.6kΩ	2 E
R99	0106332	3.3kΩ	2 E
R100	0106562	5.6kΩ	2 E
R102	0107103	10kΩ	2 B
R103	0107220	22Ω	2 B
R104	0107102	1kΩ ± 5% 1/4W C.R.	2 B
R105	0107224	220kΩ	1, 2 B
R106	0106561	560Ω ± 5% 1/4W C.R. (E.L.R.)	1, 2 B
R107	0107561	560Ω (E.L.R.)	2 B
R108	0107392	3.9kΩ ± 5% 1/4W C.R.	2 B
R109	0107123	12kΩ	2 B
R110	0106332	3.3kΩ ± 5% 1/4W C.R. (E.L.R.)	1 B, C
R111	0107272	2.7kΩ	2 B
R112	0107100	10Ω	2 B
R113	0106102	1kΩ ± 5% 1/4W C.R. (E.L.R.)	2 B
R114	0107223	22kΩ ± 5% 1/4W C.R.	2 B
R115	0106332	3.3kΩ	2 B
R116	0106102	1kΩ	2 C
R117	0106124	120kΩ	2 C
R118	0106681	680Ω	± 5% 1/4W C.R. (E.L.R.) 1, 2 C
R119	0106562	5.6kΩ	2 C
R120	0106822	8.2kΩ	2 C
R121	0106470	47Ω	2 C
R122	0107470	47Ω	± 5% 1/4W C.R. 2 C
R123	0107101	100Ω	± 5% 1/4W C.R. 2 C
R124	0106102	1kΩ	2 C
R125	0106471	470Ω	± 5% 1/4W C.R. (E.L.R.) 1, 2 C
R126	0106223	22kΩ	2 C
R127	0106103	10kΩ	2 C
R128	0107101	100Ω	2 C
R129	0107272	2.7kΩ ± 5% 1/4W C.R.	2 C
R130	0107153	15kΩ	2 C
R131	0106102	1kΩ ± 5% 1/4W C.R. (E.L.R.)	2 C
R132	0106472	4.7kΩ	± 5% 1/4W C.R. (E.L.R.) 2 C
R134	0107473	47kΩ	± 5% 1/4W C.R. 2 C
R136	0106332	3.3kΩ	± 5% 1/4W C.R. 2 C
R137	0106562	5.6kΩ	± 5% 1/4W C.R. (E.L.R.) 2 C
R138	0106562	5.6kΩ	± 5% 1/4W C.R. (E.L.R.) 2 C
R139	0106471	470Ω	± 5% 1/4W C.R. (E.L.R.) 2 C
R140	0107331	330Ω	± 5% 1/4W C.R. 2 C
VR01	1035190	100kΩ(B)	1, 2 D
VR02	1035170	47kΩ(B)	2 D
VR03	1035190	100kΩ(B)	2 D
VR05	1035070	1kΩ(B)	Semi-Variable Resistor (Solid Type) 2 E
VR06	1035170	47kΩ(B)	2 D

6-2. F-1504 Mic. & Tone Control Circuit Board (Stock No. 7560750 Complete Circuit Board F-1504) Conductor Side

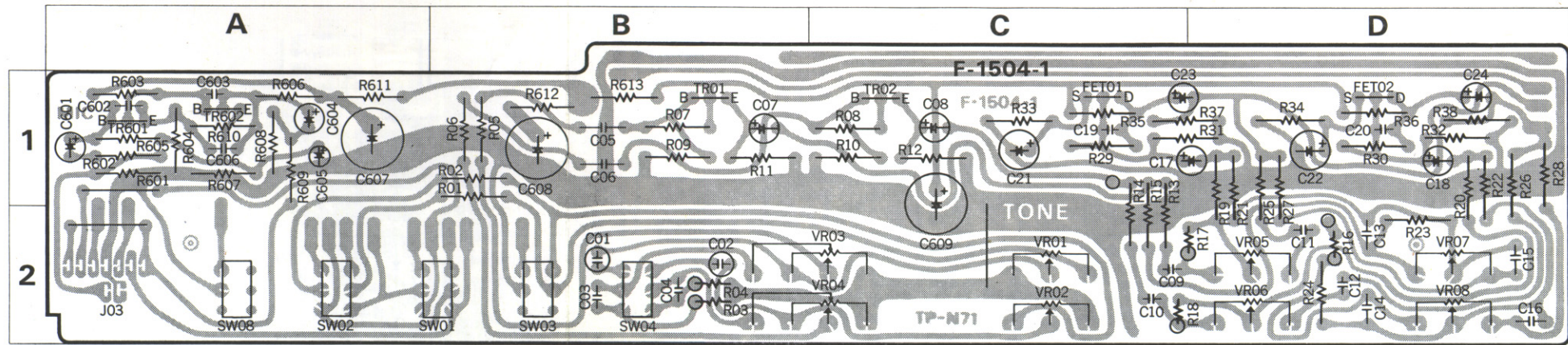

Parts List

Parts No.	Stock No.	Description	Position
TR01	0306141	2SC1362 (7)	1 B
TR02	0306141	2SC1362 (7)	1 C
TR601	0306141	2SC1362 (7)	1 A
TR602	0306141	2SC1362 (7)	1 A
FET01	0370060, 1	2SK24 (E, F)	1 C
FET02	0370060, 1	2SK24 (E, F)	1 D
C01	0620471	470pF	± 5% 50V P.C. 2 B
C02	0620471	470pF	± 5% 50V P.C. 2 B
C03	0600277	0.027μF ± 5% 50V	2 B
C04	0600277	0.027μF ± 5% 50V	2 B
C05	0601228	0.22μF ± 10% 50V	M.C. 1 B
C06	0601228	0.22μF ± 10% 50V	1 B
C07	0519102	3.3μF 50V	E.C. 1 B
C08	0519102	3.3μF 50V	E.C. 1 C
C09	0600826	0.0082μF ± 5% 50V	2 C
C10	0600826	0.0082μF ± 5% 50V	2 C
C11	0600566	0.0056μF ± 5% 50V	2 D
C12	0600566	0.0056μF ± 5% 50V	M.C. 2 D
C13	0600477	0.047μF ± 5% 50V	2 D
C14	0600477	0.047μF ± 5% 50V	2 D
C15	0600337	0.033μF ± 5% 50V	2 D
C16	0600337	0.033μF ± 5% 50V	2 D
C17	0519105	2.2μF 50V	E.C. 1 C, D
C18	0519105	2.2μF 50V	E.C. 2 D
C19	0660101	100pF 50V	C.C. 1 C
C20	0660101	100pF 50V	1 D
C21	0510101	100μF 6.3V	E.C. 1 C
C22	0510101	100μF 6.3V	E.C. 1 D
C601	0573159	1.5μF 25V	T.C. 1 A
C602	0660151	150pF 50V	C.C. 1 A
C603	0660101	100pF 50V	C.C. 1 A
C604	0519103	0.47μF 50V	1 A
C605	0510101	100μF 6.3V	1 A
C606	0515101	100μF 50V	E.C. 1 A
C607	0515101	100μF 50V	1 A
C608	0515101	100μF 50V	1 B
C609	0620391	390pF 50V	P.C. 1, 2 C

Parts No.	Stock No.	Description	Position
R01	0107103	10kΩ	1 B
R02	0107103	10kΩ ± 5% 1/4W C.R.	1 B
R03	0106183	18kΩ	± 5% 1/4W C.R. 2 B
R04	0106183	18kΩ (E.L.R.)	2 B
R05	0107471	470Ω	1 B
R06	0107471	470Ω	1 B
R07	0107334	330kΩ	1 B
R08	0107334	330kΩ	1 C
R09	0107474	470kΩ	1 B
R10	0107474	470kΩ	± 5% 1/4W C.R. 1 C
R11	0107682	6.8kΩ	1 B
R12	0107682	6.8kΩ	1 C
R13	0107821	820Ω	1, 2 C
R14	0107821	820Ω	1, 2 C
R15	0107822	8.2kΩ	1, 2 C
R16	0107822	8.2kΩ	2 D
R17	0106104	100kΩ	± 5% 1/4W C.R. (E.L.R.) 2 C, D
R18	0106104	100kΩ	2 C
R19	0107101	100Ω	1, 2 D
R20	0107101	100Ω	1, 2 D
R21	0107332	3.3kΩ	1, 2 D
R22	0107332	3.3kΩ	1, 2 D
R23	0107823	82kΩ	2 D
R24	0107823	82kΩ	2 D
R25	0107222	2.2kΩ	1, 2 D
R26	0107222	2.2kΩ	1, 2 D
R27	0107123	12kΩ	1, 2 D
R28	0107123	12kΩ	1 D
R29	0107824	820kΩ	± 5% 1/4W C.R. 1 C
R30	0107824	820kΩ	1 D
R31	0107474	470kΩ	1 C, D
R32	0107474	470kΩ	1 D
R33	0107222	2.2kΩ	1 C
R34	0107222	2.2kΩ	1 D
R35	0107103	10kΩ	1 C
R36	0107103	10kΩ	1 D
R37	0107104	100kΩ	1 C, D
R38	0107104	100kΩ	1 D
R601	0107103	10kΩ	1 A

Parts No.	Stock No.	Description	Position
R602	0107103	10kΩ	1 A
R603	0107104	100kΩ	1 A
R604	0107821	820Ω	1 A
R605	0107224	220kΩ	1 A
R606	0107562	5.6kΩ	1 A
R607	0107391	390Ω	± 5% 1/4W C.R. 1 A
R608	0107104	100kΩ	1 A
R609	0107681	680Ω	1 A
R610	0107333	33kΩ	1 A
R611	0107101	100Ω	1 A
R612	0107101	100Ω	1 B
R613	0107101	100Ω	1 B
VR01, 02	1010940	250kΩ (MN) BALANCE Volume	2 C
VR03, 04	1010920	250kΩ (B) × 2 VOLUME	2 B, C
VR05, 06	1010930	100kΩ (B) × 2 BASS Volume	2 D
VR07, 08	1010930	100kΩ (B) × 2 TREBLE Volume	2 D
S01	1130770	Push Switch (5 Stage)	2 A, B
S02	1130770		2 A
S03	1130770		2 B
S04	1130770		2 B
S08	1130770		2 A
J01	2430240	Microphone Jack	

Abbreviations

C.R. : Carbon Resistor	BP.E.C.: Bi-Pola Electrolytic Capacitor
S.R. : Solid Resistor	C.C. : Ceramic Capacitor
Ce.R. : Cement Resistor	Mi.C. : Mica Capacitor
M.R. : Metallized Film Resistor	O.C. : Oil Capacitor
M.C. : Mylar Capacitor	P.C. : Polystyrene Capacitor
E.C. : Electrolytic Capacitor	T.C. : Tantalum Capacitor

6-3. F-1503 Equalizer Circuit Board (Stock No. 7550520 Complete Circuit Board F-1503) Conductor Side

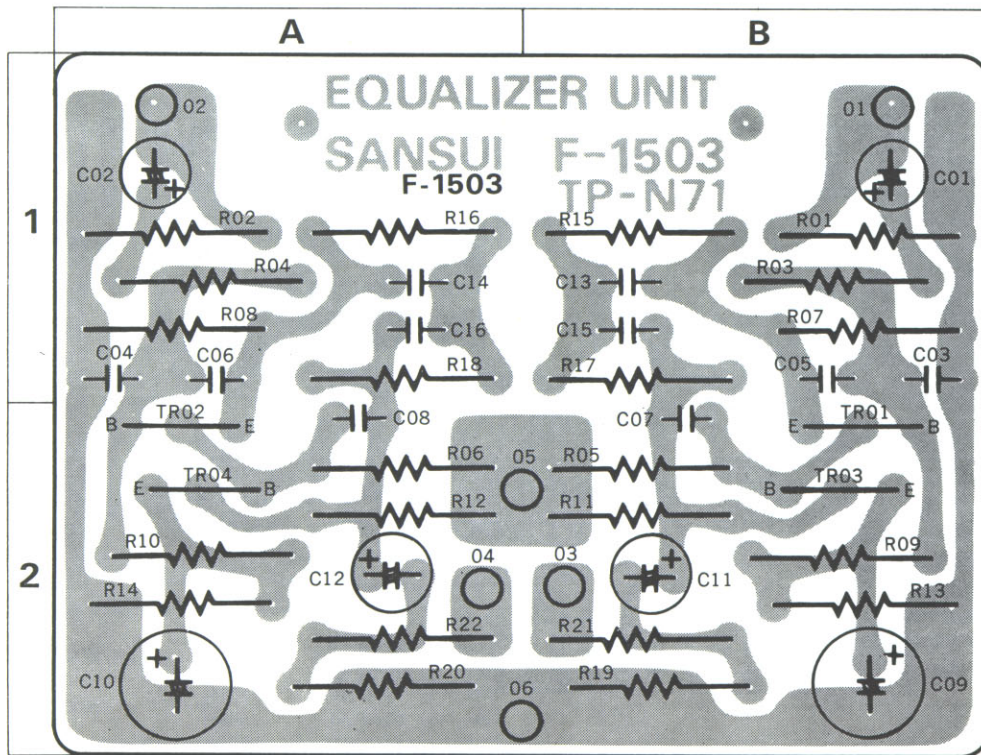

Parts List

Parts No.	Stock No.	Description	Position	Parts No.	Stock No.	Description	Position
TR01	{ 0306070, 1	2SC1313® (F, G)	2 B	C13	0600107	0.01 μF	1 B
	{ or	or		C14	0600107	0.01 μF	± 5 % 50V M.C. 1 A
	{ 0306011	2SC1222 (E, F)		C15	0600276	0.0027 μF	1 B
	{ or	or		C16	0600276	0.0027 μF	1 A
TR02	{ 0305880, 1	2SC1000 (GR, BL)	2 A	R01	0107563	56k Ω	1 B
	{ 0306070, 1	2SC1313® (F, G)		R02	0107563	56k Ω	1 A
	{ or	or		R03	0107222	2.2k Ω	1 B
	{ 0306011	2SC1222 (E, F)		R04	0107222	2.2k Ω	1 A
TR03	{ 0305880, 1	2SC1000 (GR, BL)	2 B	R05	0107104	100k Ω	2 B
	{ 0306070, 1	2SC1313® (F, G)		R06	0107104	100k Ω	2 A
	{ or	or		R07	0107821	820 Ω	1 B
	{ 0306011	2SC1222 (E, F)		R08	0107821	820 Ω	1 A
TR04	{ 0305880, 1	2SC1000 (GR, BL)	2 A	R09	0107224	220k Ω	2 B
	{ 0306070, 1	2SC1313® (F, G)		R10	0107224	220k Ω	2 A
	{ or	or		R11	0107472	4.7k Ω	± 5 % 1/4W C.R. 2 B
	{ 0306011	2SC1222 (E, F)		R12	0107472	4.7k Ω	2 A
C01	0573159	1.5 μF	25V	T.C.	1 B		
C02	0573159	1.5 μF	25V	T.C.	1 A		
C03	0660330	33 pF	50V	C.C.	1 B		
C04	0660330	33 pF	50V		1 A		
C07	0660151	150 pF	50V		2 B		
C08	0660151	150 pF	50V		2 A		
C09	0510101	100 μF	6.3V	E.C.	2 B		
C10	0510101	100 μF	6.3V		2 A		
C11	0519103	0.47 μF	50V		2 B		
C12	0519103	0.47 μF	50V		2 A		
R01	0107563	56k Ω	1 B				
R02	0107563	56k Ω	1 A				
R03	0107222	2.2k Ω	1 B				
R04	0107222	2.2k Ω	1 A				
R05	0107104	100k Ω	2 B				
R06	0107104	100k Ω	2 A				
R07	0107821	820 Ω	1 B				
R08	0107821	820 Ω	1 A				
R09	0107224	220k Ω	2 B				
R10	0107224	220k Ω	2 A				
R11	0107472	4.7k Ω	2 B				
R12	0107472	4.7k Ω	2 A				
R13	0107271	270 Ω	2 B				
R14	0107271	270 Ω	2 A				
R15	0107394	390k Ω	1 B				
R16	0107394	390k Ω	1 A				
R17	0107273	27k Ω	1 B				
R18	0107273	27k Ω	1 A				
R19	0107104	100k Ω	2 B				
R20	0107104	100k Ω	2 A				
R21	0107681	680 Ω	2 B				
R22	0107681	680 Ω	2 A				

6-4. F-1505 Filter Circuit Board

(Stock No. 7591910 Complete Circuit Board F-1505)

Conductor Side

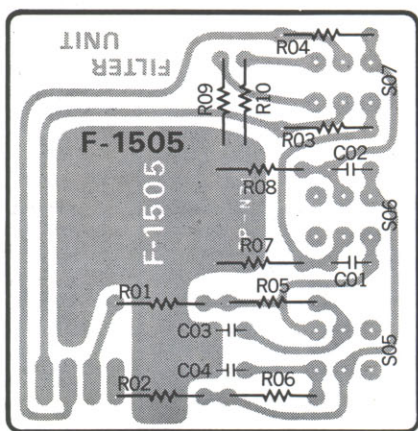

Parts List

Parts No.	Stock No.	Description
C01	0600277	0.027 μ F
C02	0600277	0.027 μ F
C03	0600187	0.018 μ F
C04	0600187	0.018 μ F
		$\pm 5\%$ 50V M.C.
R01	0107332	3.3k Ω
R02	0107332	3.3k Ω
R03	0107473	47k Ω
R04	0107473	47k Ω
R05	0107824	820k Ω
R06	0107824	820k Ω
R07	0107104	100k Ω
R08	0107104	100k Ω
R09	0107472	4.7k Ω
R10	0107472	4.7k Ω
		$\pm 5\%$ $\frac{1}{4}$ W C.R.
S05	1130790	Push Switch (3 Stage)
S06		
S07		

6-5. F-1490 De-emphasis Circuit Board

(Stock No. 7591890 Complete Circuit Board F-1490)

Conductor Side

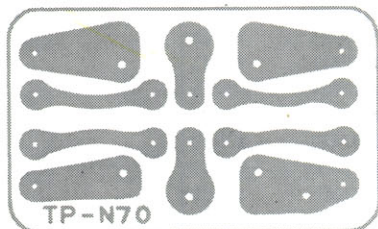

Parts List

Parts No.	Stock No.	Description
C01	0600826	0.0082 μ F
C02	0600826	0.0082 μ F
		$\pm 5\%$ 50V M.C.
S12	1110240	Slide Switch

6-6. F-1499A Driver Circuit Board

(Stock No. 7570800 Complete Circuit Board F-1499A)

Parts List

Parts No.	Stock No.	Description	Position
TR01	0300303, 5	2SA640 (K, L)	2 B
TR02	0300303, 5	2SA640 (K, L)	2 A
TR03	0300303, 5	2SA640 (K, L)	2 B
TR04	0300303, 5	2SA640 (K, L)	2 A
TR05	0305901	2SC1124 (2)	1 B
TR06	0305901	2SC1124 (2)	1 A
TR07	0305121, 2	2SC281 (B, C)	1 B
TR08	0305121, 2	2SC281 (B, C)	1 A
TR09	0305901, 2	2SC1124 (2, 3)	2 B
TR10	0305901, 2	2SC1124 (2, 3)	2 A
TR11	0300390, 1	2SA706 $\text{\textcircled{B}}$ (1, 2)	2 B
TR12	0300390, 1	2SA706 $\text{\textcircled{B}}$ (1, 2)	2 A
		Transistor	
D01	0340090	DS-430	1 B
D02	0340090	DS-430	1 A
D03	0340090	DS-430	1 B
D04	0340090	DS-430	1 A
ZD01	0316220	RD-8.2E (B)	1 B
ZD02	0316220	RD-8.2E (B)	1 A
		Zener Diode	
C01	0519103	0.47 μ F	50V E.C. 2 B
C02	0519103	0.47 μ F	2 A
C03	0660150	150pF	50V C.C. 2 B
C04	0660150	150pF	2 A
C05	0511221	220 μ F	50V E.C. 2 B
C06	0511221	220 μ F	2 A
C07	0660100	10pF	$\pm 50\%$ 50V C.C. 1 B
C08	0660100	10pF	1 A
C09	0515330	33 μ F	50V E.C. 1 B
C10	0515330	33 μ F	1 A
C11	0660100	10pF	50V C.C. 1 B
C12	0660100	10pF	1 A
C13	0515101	100 μ F	50V E.C. 2 B
C14	0515101	100 μ F	2 A
C17	0757473	0.047 μ F	50V C.C. 2 B
C18	0757473	0.047 μ F	2 A
R01	0107104	100k Ω	2 B
R02	0107104	100k Ω	2 A
R03	0107222	2.2k Ω	2 B
R04	0107222	2.2k Ω	2 A
R05	0107104	100k Ω	1 B
R06	0107104	100k Ω	1 A
R07	0107223	22k Ω	1 B
R08	0107223	22k Ω	1 A
R09	0107683	68k Ω	1 B
R10	0107683	68k Ω	1 A
R11	0107103	10k Ω	1 B
R12	0107103	10k Ω	$\pm 5\%$ $\frac{1}{4}$ W C.R. 1 A
R13	0107100	10 Ω	1 B
R14	0107100	10 Ω	1 A
R15	0107100	10 Ω	1 B
R16	0107100	10 Ω	1 A
R17	0107152	1.5k Ω	1 B
R18	0107152	1.5k Ω	1 A
R19	0107082	6.8k Ω	1 B
R20	0107082	6.8k Ω	1 A
R21	0107104	100k Ω	1 B
R22	0107104	100k Ω	1 A

Conductor Side

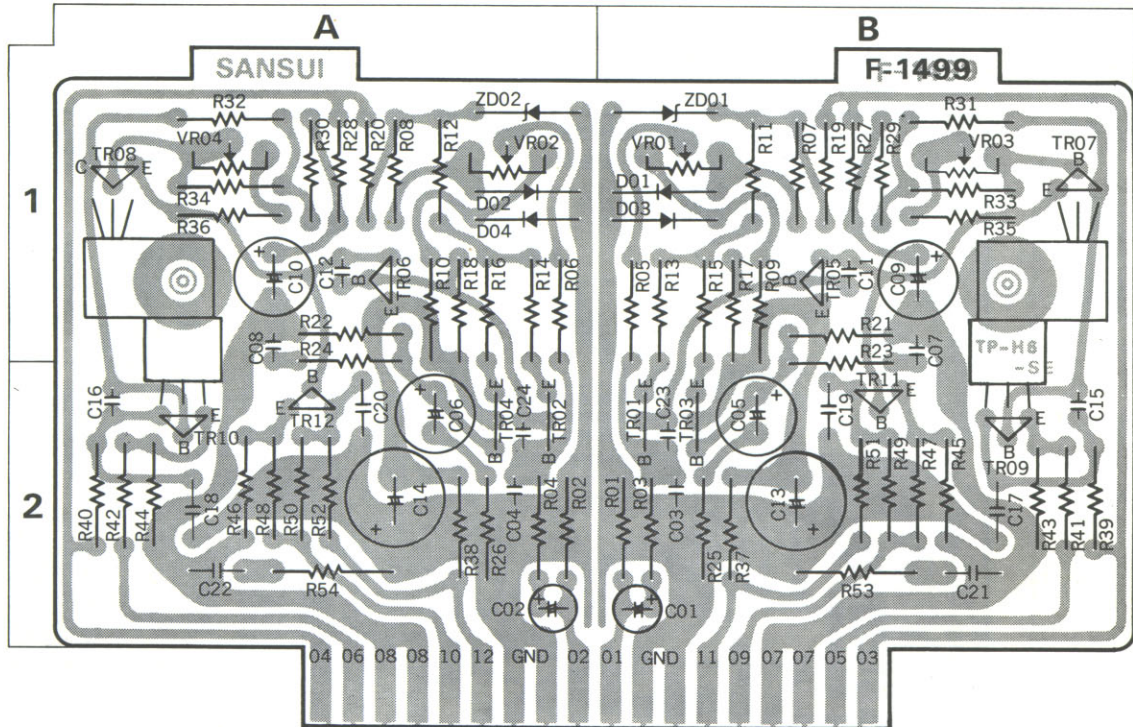

Parts No.	Stock No.	Description	Position
R23	0107103	10kΩ	1, 2 B
R24	0107103	10kΩ	1, 2 A
R25	0107471	470Ω	2 B
R26	0107471	470Ω	2 A
R27	0107182	1.8kΩ	1 B
R28	0107182	1.8kΩ	1 A
R29	0107472	4.7kΩ	1 B
R30	0107472	4.7kΩ	1 A
R31	0107392	39Ω	1 B
R32	0107392	39Ω	1 A
R33	0107332	3.3kΩ	1 B
R34	0107332	3.3kΩ	1 A
R35	0107152	1.5kΩ	1 B
R36	0107152	1.5kΩ	1 A
R37	0107151	150Ω	2 B
R38	0107151	150Ω	2 A
R39	0107100	10Ω	2 B
R40	0107100	10Ω	2 A
R41	0107479	4.7Ω	2 B
R42	0107479	4.7Ω	2 A
R43	0107221	220Ω	2 B
R44	0107221	220Ω	2 A
R45	0107479	4.7Ω	2 B
R46	0107479	4.7Ω	2 A
R49	0107479	4.7Ω	2 B
R50	0107479	4.7Ω	2 A
R51	0107221	220Ω	2 B
R52	0107221	220Ω	2 A
VR01	1033091	5kΩ (B)	1 B
VR02	1033091	5kΩ (B)	1 A
VR03	1033051	1kΩ (B)	1 B
VR04	1033051	1kΩ (B)	1 A

± 5% ¼W C.R.

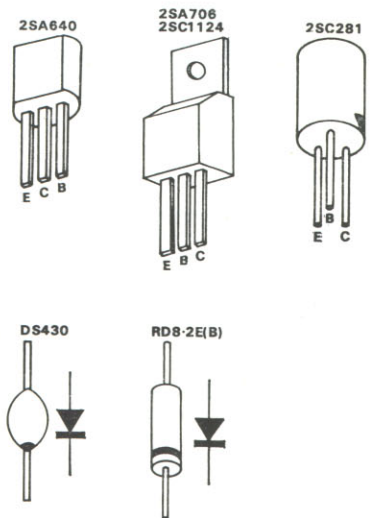

— Abbreviations —

C.R. : Carbon Resistor	BP.E.C.: Bi-Pola Electrolytic Capacitor
S.R. : Solid Resistor	C.C. : Ceramic Capacitor
Ce.R. : Cement Resistor	Mi.C. : Mica Capacitor
M.R. : Metallized Film Resistor	O.C. : Oil Capacitor
M.C. : Mylar Capacitor	P.C. : Polystyrene Capacitor
E.C. : Electrolytic Capacitor	T.C. : Tantalum Capacitor

6-7. F-1500C Power Circuit Board (Stock No. 7591950 Complete Circuit Board F-1500C)
Conductor Side

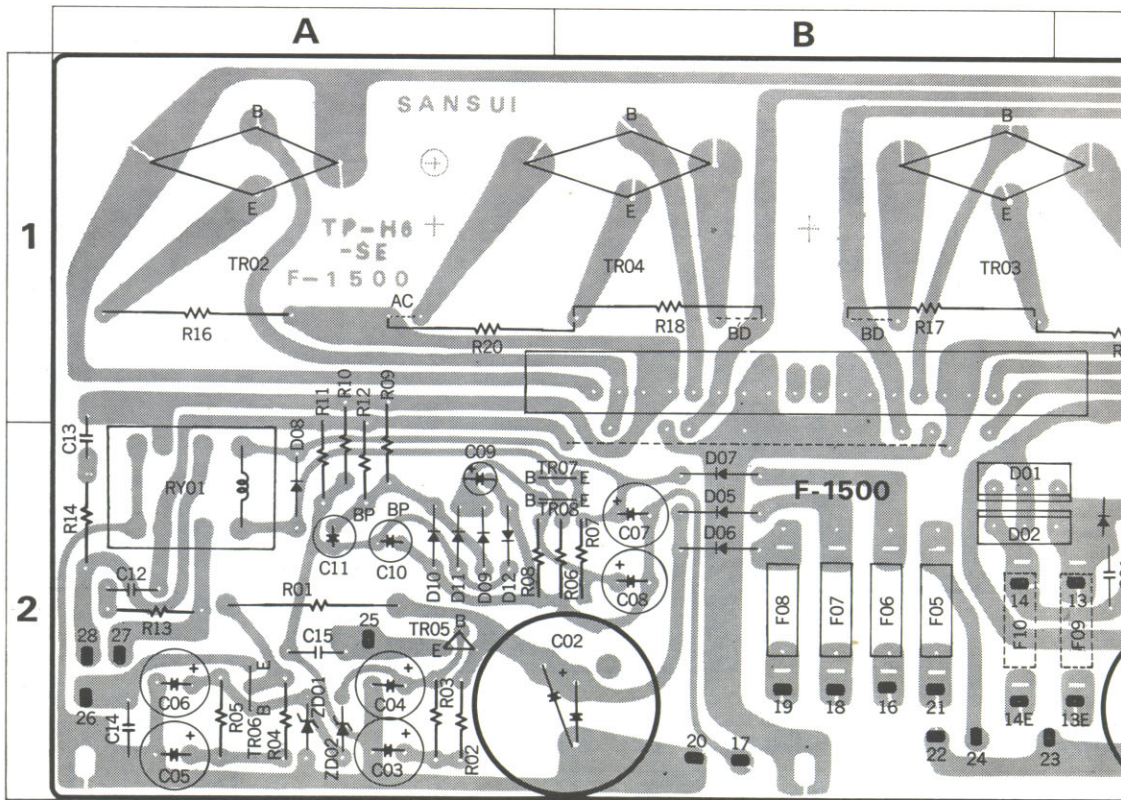

Parts List

Parts No.	Stock No.	Description	Position	Parts No.	Stock No.	Description	Position
TR01	0306150~2	2SC1402 (R, O, Y)	1 C	C01	0659011	0.01 μ F 500V	C.C. 2 C
TR02	0306150~2	2SC1402 (R, O, Y)	1 A	C02	0549103	1000 μ F 50V	2 A, B
TR03	0306150~2	2SC1402 (R, O, Y)	1 B	C03	0515221	220 μ F 50V	2 A
TR04	0306150~2	2SC1402 (R, O, Y)	1 B	C04	0515470	47 μ F 50V	2 A
TR05	0305981, 2	2SC875 (E, F)	2 A	C05	0513101	100 μ F 25V	2 A
TR06	0303861, 2	2SD330 (D, E)	2 A	C06	0512101	100 μ F 16V	E.C. 2 A
TR07	0306131, 2	2SC1364 (6, 7)	2 A, B	C07	0515470	47 μ F 50V	2 B
TR08	0306131, 2	2SC1364 (6, 7)	2 A, B	C08	0510221	220 μ F 6.3V	2 B
D01	0310680	10DC-1	2 B	C09	0515109	1 μ F 50V	2 A
D02	0310680	10DC-1	2 B	C10	0535109	1 μ F 50V	2 A
D03	0310670	10DC-1R	2 C	C11	0530470	47 μ F 6.3V	BP.E.C. 2 A
D04	0310670	10DC-1R	2 C	C12	0601108	0.1 μ F $\pm 10\%$	50V M.C. 2 A
D05	0310340	10D-1	2 B	C13	0601108	0.1 μ F $\pm 10\%$	50V M.C. 2 A
D06	0310340	10D-1	2 B	C14	0657473	0.047 μ F	50V C.C. 2 A
D07	0310340	10D-1	2 B	C15	0657473	0.047 μ F	50V C.C. 2 A
D08	0310340	10D-1	2 A	R01	0183221	220 Ω	3W Ce.R. 2 A
D09	0310400	1N34A	2 A	R02	0107122	1.2k Ω	2 A
D10	0310400	1N34A	2 A	R03	0107332	3.3k Ω	2 A
D11	0310400	1N34A	2 A	R04	0107122	1.2k Ω	2 A
D12	0310400	1N34A	2 A	R05	0107332	3.3k Ω	2 A
ZD01	0315310	RD13A (N)	2 A	R06	0107100	10 Ω	$\pm 5\%$ 1/4W C.R. 2 B
ZD02	0315480	RD35A (L)	2 A	R07	0107823	82k Ω	2 B
				R08	0107223	22k Ω	2 A
				R09	0107473	47k Ω	2 A

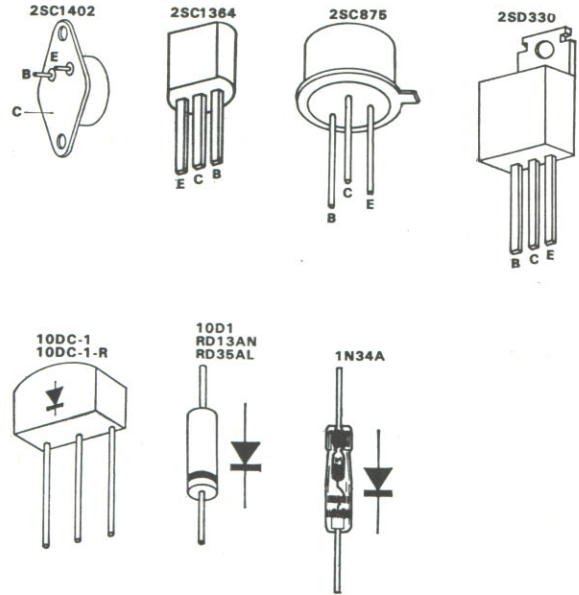
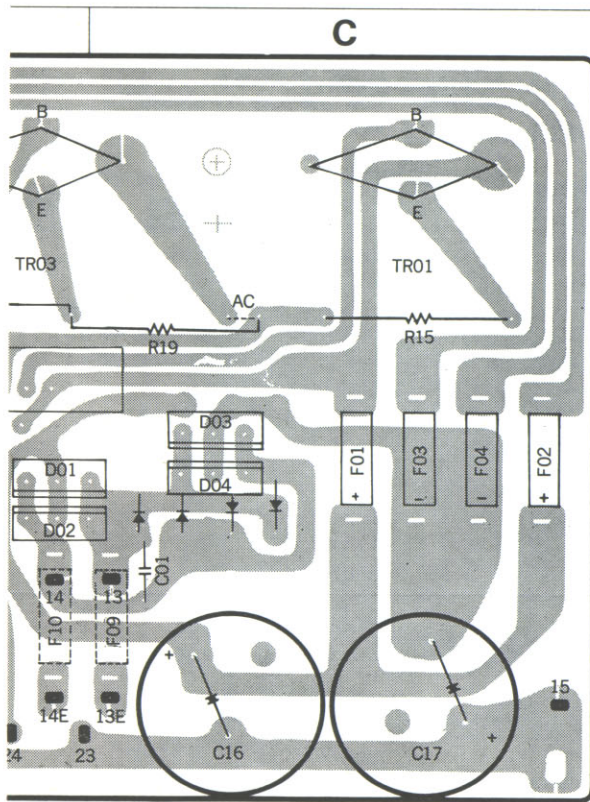

Parts No.	Stock No.	Description	Position
R10	0107473	47kΩ	2 A
R11	0107332	3.3kΩ	± 5% 1/4W C.R. 2 A
R12	0107332	3.3kΩ	
R13	0103100	10Ω	
R14	0103100	10Ω	± 5% 1/2W C.R. 2 A
R15	0133338	0.33Ω	
R16	0133338	0.33Ω	3W 1 A
R17	0133338	0.33Ω	3W Ce.R 1 B
R18	0133338	0.33Ω	3W 1 B
F01	0433640	5A	Quick Acting Fuse 2 C
F02	0433640	5A	
F03	0433640	5A	
F04	0443640	5A	
F05	0432900	5A	Power Fuse 2 B
F06	0432830	1A	
F07	0432850	2A	
F08	0432850	2A	
RY01	1150250	MY2-0 (24V, 5A) Relay	2 A
	2420170	18P Connector	
	2310150	Fuse Holder	
	2260010	Test Pin	

Abbreviations

C.R. : Carbon Resistor	BP.E.C.: Bi-Pola Electrolytic Capacitor
S.R. : Solid Resistor	C.C. : Ceramic Capacitor
Ce.R. : Cement Resistor	Mi.C. : Mica Capacitor
M.R. : Metallized Film Resistor	O.C. : Oil Capacitor
M.C. : Mylar Capacitor	P.C. : Polystyrene Capacitor
E.C. : Electrolytic Capacitor	T.C. : Tantalum Capacitor

6-8. Other Parts (Front Side) Parts List

Parts No.	Stock No.	Description	Parts No.	Stock No.	Description
1	5101165	Binding Head Screw, M4×14	62	5109122	Binding Head Tapping Screw, M3×8
2	5186110	Plain Washer, 4φ	63	5269330	Holder, signal meter
3	5101165	Binding Head Screw, M4×14	64	0420040	Fuse Type Lamp (7V 300mA)
4	5186110	Plain Washer, 4φ	65	7726050	Meter Lamp Ass'y
5	5101165	Binding Head Screw, M4×14	66	4300610	Signal Meter
6	5186110	Plain Washer, 4φ	67	0400300	Lead Type Lamp (7V 100mA), STEREO Indicator
7	5101165	Binding Head Screw, M4×14	68	5109122	Binding Head Tapping Screw, M3×8
8	5186110	Plain Washer, 4φ	69	5109122	Binding Head Tapping Screw, M3×8
9	5726840	Wood Bonnet	70	0420040	Fuse Type Lamp (7V 300mA)
10	5317720	L-1 Type Knob, SPEAKERS	71	5066211	Illuminator Box
11		Hex. Nut, M9	72	5109122	Binding Head Tapping Screw, M3×8
12	5326410	Push Button	73	5109122	Binding Head Tapping Screw, M3×8
13	5317740	S-3 Type Knob, BASS volume	74	5269340	P.C.B Holder
14	5317740	S-3 Type Knob, TREBLE volume	75	5101161	Binding Head Screw, M4×6
15	5317740	S-3 Type Knob, BALANCE volume	76	5101161	Binding Head Screw, M4×6
16	5317820	T-6 Type Knob, TUNING	77	5101165	Binding Head Screw, M4×14
17	5317720	L-1 Type Knob, VOLUME	78	5516911	Rubber Foot
18		Hex. Nut, M9	79	5101165	Binding Head Screw, M4×14
19	5317730	M-3 Type Knob, SELECTOR	80	5516911	Rubber Foot
20		Hex. Nut, M9	81	5058130	Bottom Plate
21	5326410	Push Button			
22	5102543	Flat Countersunk Head Screw, M3×6			
23	5102543	Flat Countersunk Head Screw, M3×6			
24	5308950	Front Panel			
25	5101043	Binding Head Screw, M3×6			
26	5101043	Binding Head Screw, M3×6			
27	5101043	Binding Head Screw, M3×6			
28	5101043	Binding Head Screw, M3×6			
29	5047700	Smoked Plate			
30	5308910	Frame, smoked plate			
31	7106083	Push Button, POWER switch			
32	6906031	Spring, POWER switch			
33	1130350	Push Switch, POWER			
34		Hex. Nut, M9			
35		Plain Washer, 9φ			
36	2430200	Headphone Jack			
37	5236481	Spacer Nut, M9			
38		Plain Washer, 9φ			
39	1102400	Rotary Switch Y-2-2-6, SPEAKERS			
40	1130790	Push Switch (3 Stage)			
41		Hex. Nut, M8			
42		Plain Washer, 8φ			
43	1010930	100kΩ (B)×2 BASS Volume			
44		Hex. Nut, M8			
45		Plain Washer, 8φ			
46	1010930	100kΩ (B)×2 TREBLE Volume			
47		Hex. Nut, M8			
48		Plain Washer, 8φ			
49	1010940	250kΩ (MN) BALANCE Volume			
50	5236451	Spacer Nut, M8			
51		Plain Washer, 8φ			
52	1010920	250kΩ (B)×2 VOLUME			
53	1130770	Puse Switch (5 Stage)			
54		Hex. Nut, M12			
55		Plain Washer, 12φ			
56	2430240	Microphone Jack			
57	5236481	Spacer Nut, M9			
58		Plain Washer, 9φ			
59	7036380	Tuning Ass'y			
60	5416361	Dial Pointer			
61	5109122	Binding Head Tapping Screw, M3×8			

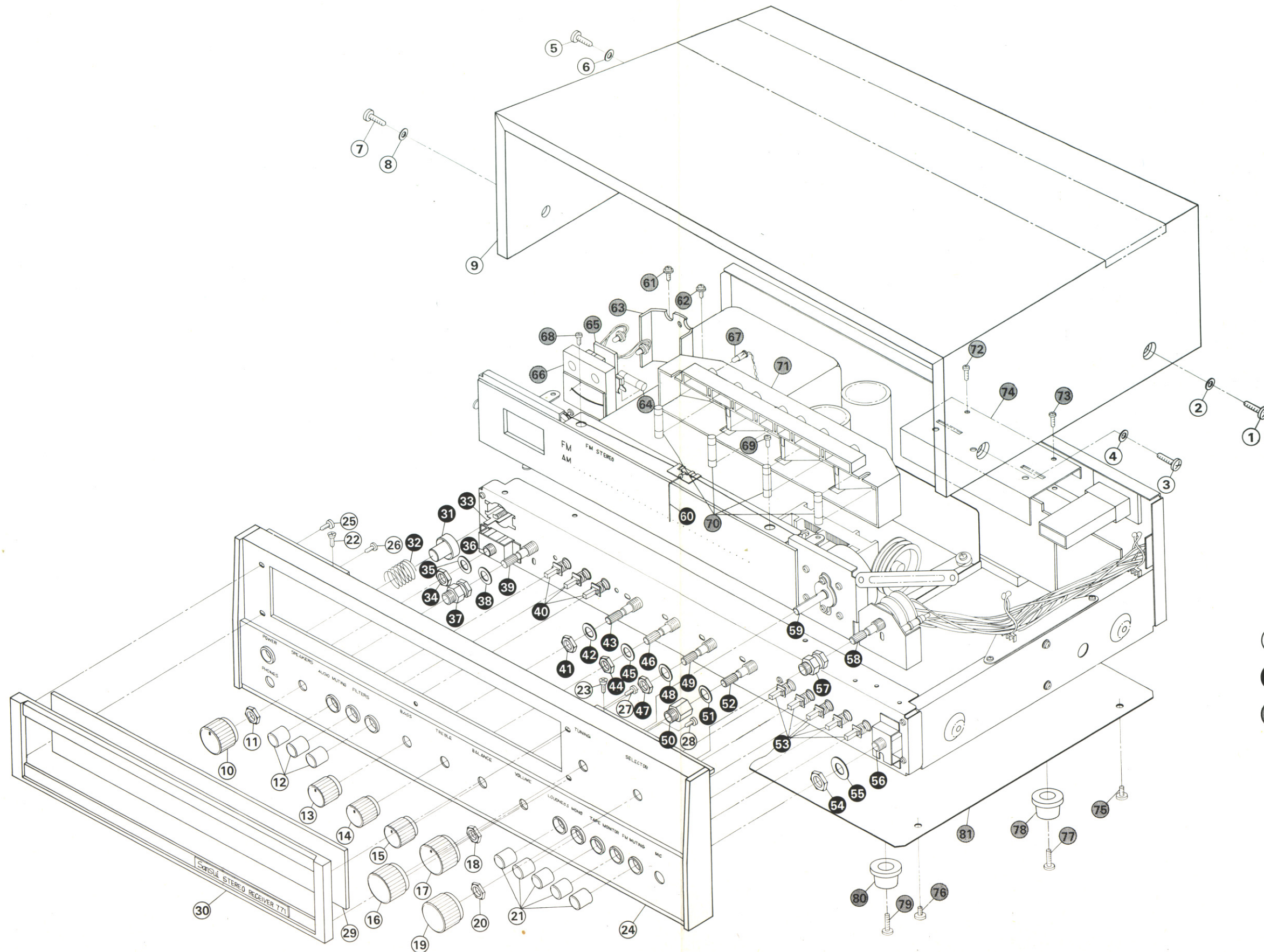

- 1 ~ 30
- 31 ~ 60
- 61 ~ 81

6-9. Other Parts (Top Side)

6-10.

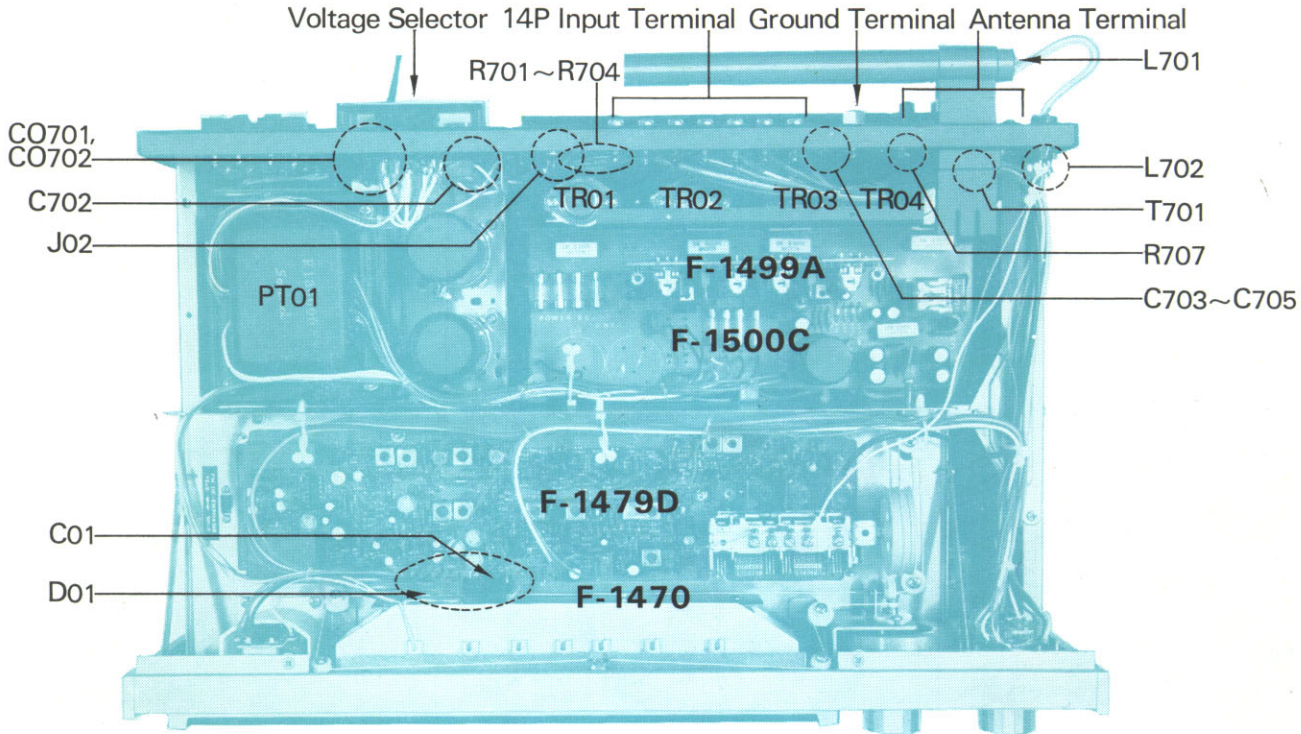

Top Side Parts List

Parts No.	Stock No.	Description
D01	0310880	10D05 Diode
C01	0501331	330 μ F 10V E.C.
C702	0659802	0.0047 μ F 1.4kV
C703	0657473	0.047 μ F 50V
C704	0657473	0.047 μ F 50V
C705	0657473	0.047 μ F 50V
R701	0107104	100k Ω
R702	0107104	100k Ω
R703	0107184	180k Ω
R704	0107184	180k Ω
R707	0103122	1.2k Ω \pm 5% $\frac{1}{2}$ W C.R.
J02	2430040	DIN Connector
L701	4200610	Bar Antenna
L702	4900100	Micro-Inductor
CO701, 702	2450040	AC Outlet
T701	4290021	75 Ω : 300 Ω FM Balun

Parts No.	Stock No.	Description
PT01	4001390	Power Transformer
	2200370	14P Input Terminal
	2210190	Antenna Terminal
	2230050	Ground Terminal
	2410080	Voltage Selector, socket
	2410090	Voltage Selector, plug

Bottom

Parts No.
TR01
TR02
TR03
TR04
C701
C706
C707
R705
R706
F701
J01
J03

6-10. Other Parts (Bottom Side)

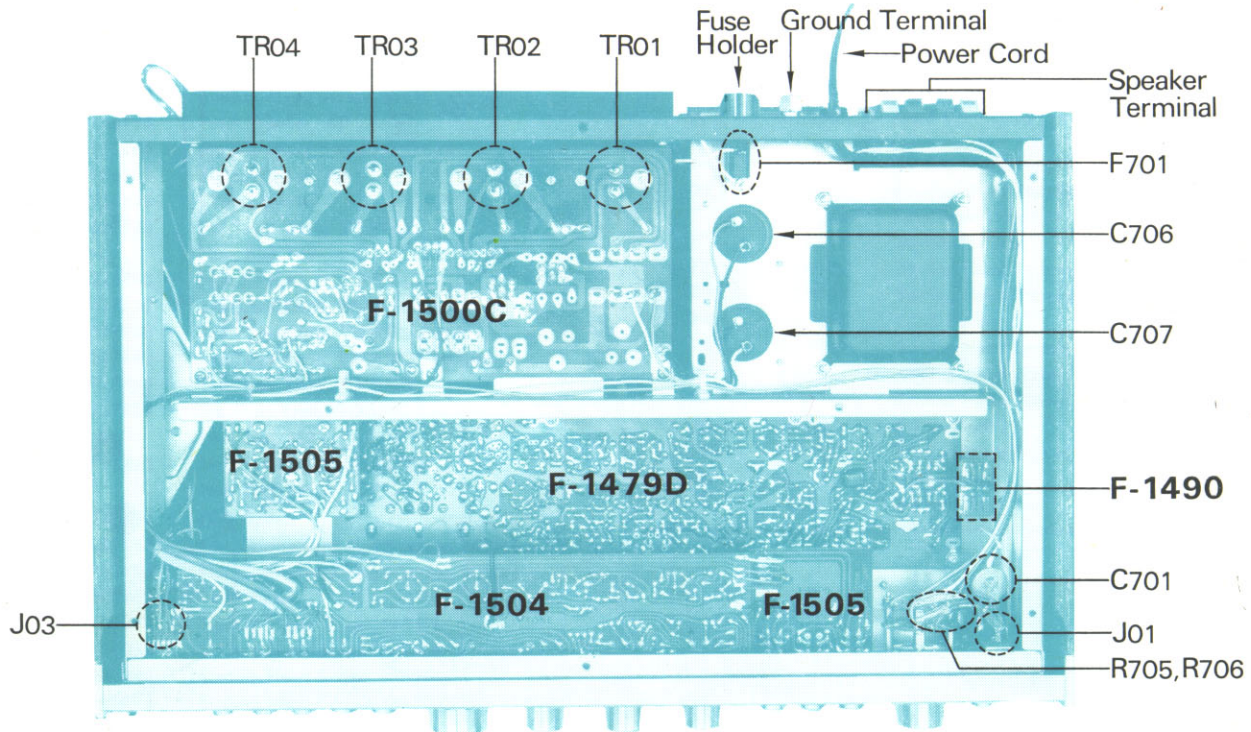

Bottom Side Parts List

Parts No.	Stock No.	Description
TR01	0306150-2	2SC1402 (O, R, Y)
TR02	0306150-2	2SC1402 (O, R, Y)
TR03	0306150-2	2SC1402 (O, R, Y)
TR04	0306150-2	2SC1402 (O, R, Y)
		} Transistor
C701	0659802	0.0047 μ F 1.4kV C.C.
C706	0559322	4700 μ F 50V } E.C.
C707	0559322	4700 μ F 50V }
R705	0171561	560 Ω } $\pm 10\%$ 1 W M.R.
R706	0171561	560 Ω }
F701	0431280	5A Power Fuse (100~117V)
	0431260	3A Power Fuse (220~240V)
	2300060	Fuse Holder
J01	2430200	Headphone Jack
J03	2432400	Microphone Jack
	3800020	Power Cord
	2290100	4P Speaker Terminal
	2230050	Ground Terminal

Abbreviations

C.R. : Carbon Resistor	BP.E.C.: Bi-Pola Electrolytic Capacitor
S.R. : Solid Resistor	C.C. : Ceramic Capacitor
Ce.R. : Cement Resistor	Mi.C. : Mica Capacitor
M.R. : Metallized Film Resistor	O.C. : Oil Capacitor
M.C. : Mylar Capacitor	P.C. : Polystyrene Capacitor
E.C. : Electrolytic Capacitor	T.C. : Tantalum Capacitor

7. SCHEMATIC DIAGRAM OF TUNER SECTION

* Design and specifications subject to change without notice for improvements.

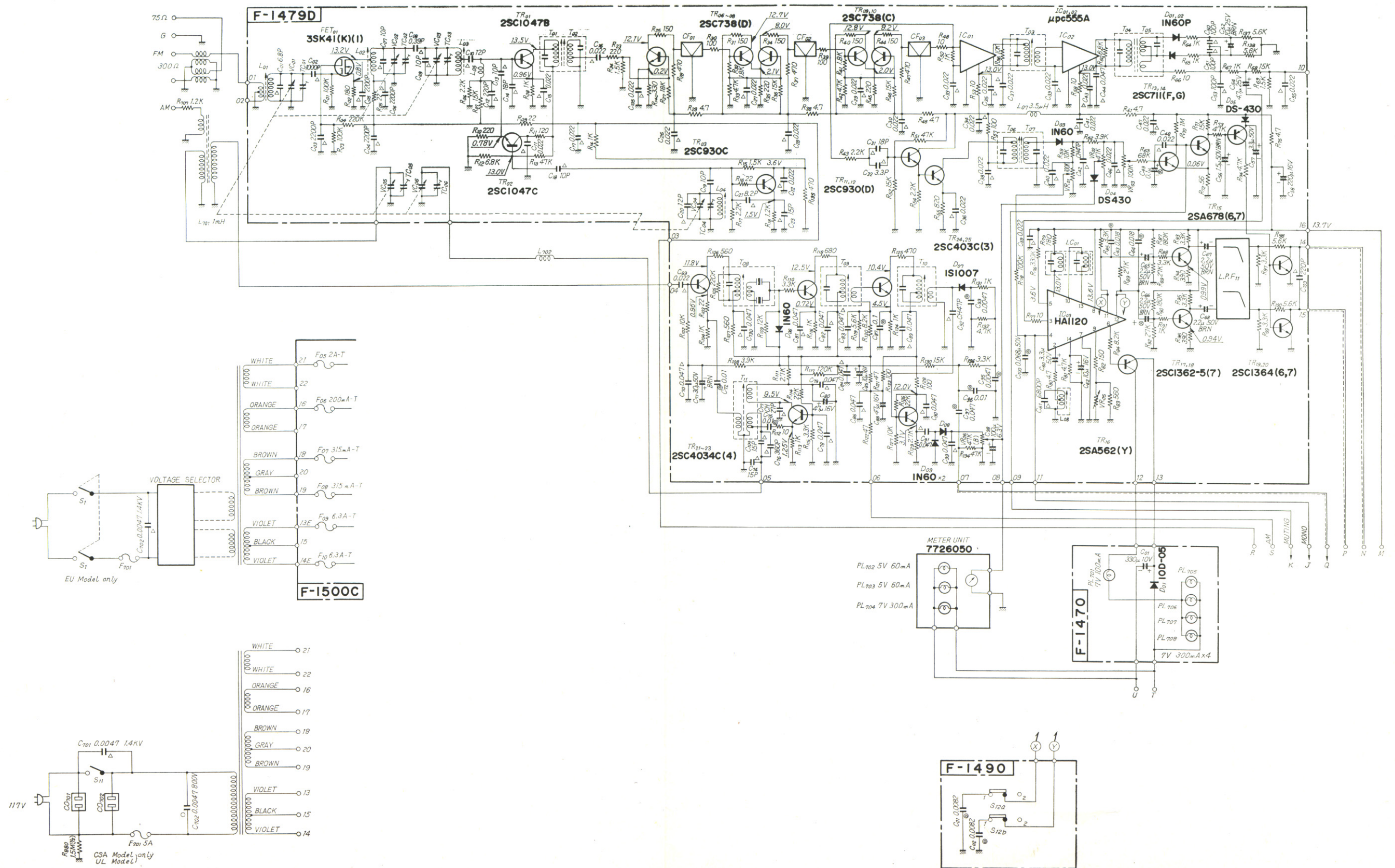

8. SCHEMATIC DIAGRAM OF AUDIO SECTION

* Design and specifications subject to change without notice for improvements.

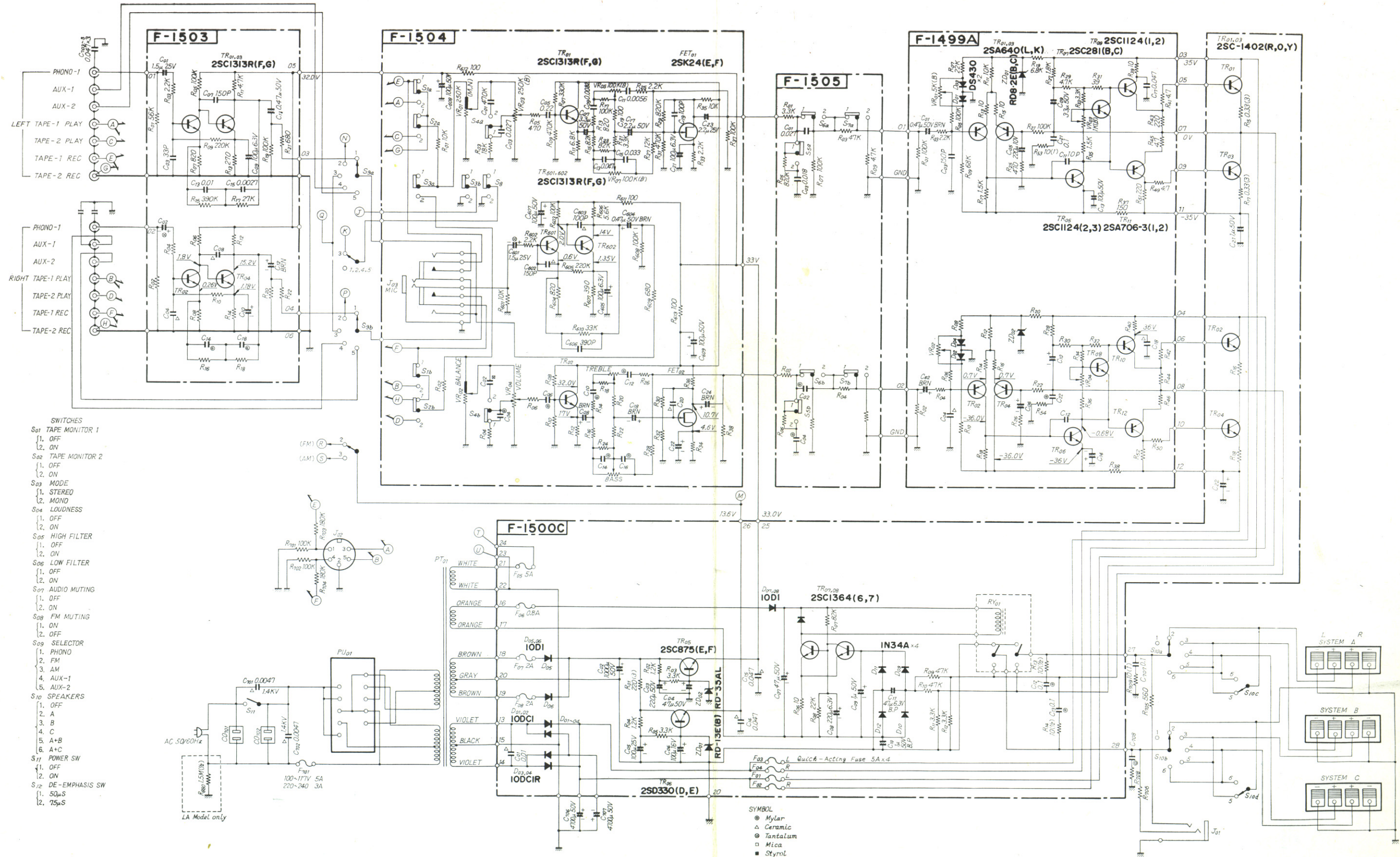

9. PACKING LIST

Parts No.	Stock No.	Description
1	9017340	Inner Packing (upper)
2	9027770	Stylofoam Packing
3	9007540	Carton Case

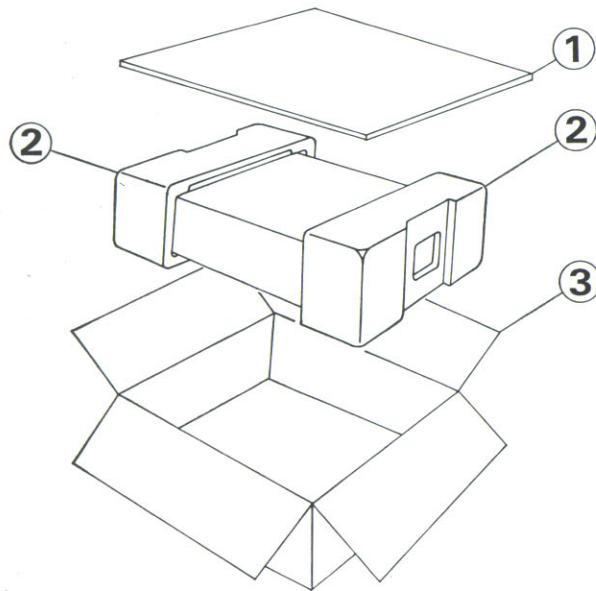

11. MAINTENANCE

11-1. Voltage Adjustment

The Voltage Selector on the rear panel enables you to operate at correct voltage in any areas. The voltage has been preadjusted at the factory, but can be easily changed as follows, according to the line voltage using in your area.

- 1) Remove the two screws securing the name plate on the unit's rear panel, then remove the name plate.
- 2) Unplug the Voltage Selector plug once, and reset it so that the arrow mark on it faces the correct voltage indication. Also change the power fuse when the power supply voltage has change. For 100/117 volt operation, use a 5-ampere glass-tubed fuse. For 220/240 volt operation, use a 3-ampere one.

Note: The Voltage Selector can be used to eliminate the trouble caused by the considerable voltage fluctuation. In this case, it should be set to the peak voltage.

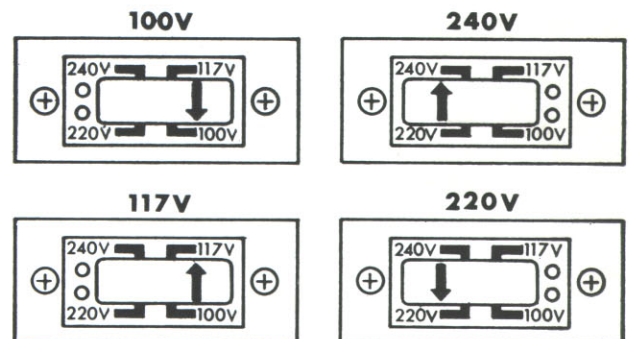

10. ACCESSORY PARTS LIST

Stock No.	Description
9406020	Polishing Cloth
0433640	5A Quick Acting Fuse
9207920	Operating Instructions
9227920	Operating Instruction Sheet

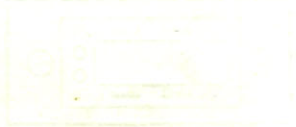

SANSUI ELECTRIC CO., LTD.
14-1, 2-chome, Izumi, Suginami-ku, Tokyo 168, Japan.
TELEPHONE: (03) 323-1111/TELEX: 232-2076

SM008

Printed in Japan (D3050M)