



1. SPECIFICATIONS

# SERVICE MANUAL

AM/FM STEREO RECEIVER

**SANSUI 881**



SANSUI ELECTRIC CO., LTD.

This service manual is designed for service engineers to repair, adjust, maintain and order the replacement parts of the 881 correctly. When ordering the parts, use the stock number and parts name specifically referring to the Parts Locations & Parts Lists. For general usage and maintenance of the unit, please refer to the Operating Instructions attached with the unit.

## TABLE OF CONTENTS

<u>Section</u>	<u>Title</u>	<u>Page</u>
<b>1.</b>	<b>SPECIFICATIONS</b>	<b>2</b>
<b>2.</b>	<b>BLOCK DIAGRAM AND VALUE OF EACH LEVEL</b>	<b>3</b>
<b>3.</b>	<b>ALIGNMENTS AND ADJUSTMENTS</b>	<b>4</b>
3-1.	Driver Circuit Board Adjustment	4
3-2.	FM IF Alignment	5
3-3.	FM Dial Calibration, MONO Distortion and RF Alignment	5, 6
3-4.	MPX Alignment	6
3-5.	AM IF, Dial Calibration, RF Alignment	7
<b>4.</b>	<b>TROUBLESHOOTING CHART</b>	<b>9</b>
4-1.	Troubleshooting on Power Supply Section	9
4-2.	Troubleshooting on Audio Section	9
4-3.	Troubleshooting on Tuner Section	9, 10
<b>5.</b>	<b>PARTS LOCATIONS AND PARTS LISTS</b>	<b>11</b>
5-1.	F-1507 Tuner Circuit Board	11, 12, 13
5-2.	F-1519C FM Pack	14
5-3.	F-2433 Equalizer Circuit Board	15
5-4.	F-2432 Input Terminal Board	15
5-5.	F-2434 Tone Control Circuit Board	15, 16
5-6.	F-2435 Filter Circuit Board	16
5-7.	F-2436 Driver Circuit Board	17
5-8.	F-2473 Power Supply Circuit Board	18
5-9.	Other Parts (Front Side)	19, 20
5-10.	Other Parts (Top Side)	21
5-11.	Other Parts (Bottom Side)	21
<b>6.</b>	<b>THREADING OF DIAL CORD</b>	<b>21</b>
6-1.	Threading of Dial Cord	21
6-2.	Attachment of Dial Pointer	21
<b>7.</b>	<b>SCHEMATIC DIAGRAM</b>	<b>22</b>
<b>8.</b>	<b>PACKING LIST</b>	<b>23</b>
<b>9.</b>	<b>ACCESSORY PARTS LIST</b>	<b>23</b>

# 1. SPECIFICATIONS

## AUDIO SECTION

CONTINUOUS RMS POWER OUTPUT  
 .....60 Watts per channel × 2  
 (both channels driven)

LOAD IMPEDANCE .....8Ω

POWER BAND .....20 to 20,000Hz

TOTAL HARMONIC DISTORTION  
 .....less than 0.3% (from AUX)

Music power (IHF) .....200W (4Ω 1,000Hz)  
 150W (8Ω 1,000Hz)

Continuous rms power output ..64+64W (8Ω 1,000Hz)

INTERMODULATION DISTORTION  
 (at rated power output, 70Hz : 7,000Hz = 4 : 1  
 SMPTE method)

OVERALL (from AUX) ....less than 0.3%

FREQUENCY RESPONSE (at 1 Watt power output)

OVERALL (from AUX) ....10 to 30,000Hz ±1.0dB

EQUALIZATION (at TAPE REC output)

.....RIAA Curve  
 (30 to 15,000Hz ±1.0dB)

DAMPING FACTOR .....45 (8Ω)

CHANNEL SEPARATION (1,000Hz, at rated power output)

PHONO .....better than 45dB

AUX .....better than 45dB

HUM AND NOISE (IHF)

PHONO .....better than 70dB

AUX .....better than 80dB

INPUT SENSITIVITY AND IMPEDANCE  
 (1,000Hz, for rated power output)

PHONO .....2.5mV 50kΩ  
 (Max. input capability: 200mV at 0.5% distortion)

MIC (monophonic) .....2.5mV 50kΩ

AUX-1, -2 .....100mV 50kΩ

TAPE-1

PLAY Pin Jacks .....100mV 50kΩ

REC/PLAY DIN Socket ..100mV 50kΩ

TAPE-2 (4-CH ADAPTOR)

PLAY Pin Jacks .....100mV 50kΩ

RECORDING OUTPUT

TAPE-1

REC Pin Jacks .....100mV

REC/PLAY DIN Socket ..30mV

TAPE-2 (4-CH ADAPTOR)

REC Pin Jacks .....100mV

SWITCHES AND CONTROLS

BASS ..... +10dB, -10dB at 50Hz

MIDRANGE ..... +5dB, -5dB at 1,500Hz

TREBLE ..... +10dB, -10dB at 10,000Hz

LOUDNESS ..... +10dB at 50Hz  
 +8dB at 10,000Hz

LOW FILTER ..... -10dB at 50Hz (6dB/oct.)

HIGH FILTER ..... -10dB at 10,000Hz  
 (6dB/oct.)

## TUNER SECTION

<FM>

TUNING RANGE .....88 to 108MHz

SENSITIVITY (IHF) .....1.8μV

TOTAL HARMONIC DISTORTION

MONO .....0.3%

STEREO.....0.5%

SIGNAL TO NOISE RATIO ..better than 70dB

SELECTIVITY .....better than 70dB

CAPTURE RATIO .....1.5dB

IMAGE REJECTION .....better than 75dB at 98MHz

IF REJECTION .....better than 90dB at 98MHz

SPURIOUS RESPONSE REJECTION  
 .....better than 80dB at 98MHz

SPURIOUS RADIATION ....less than 34dB

STEREO SEPARATION .....better than 40dB at 1,000Hz

FREQUENCY RESPONSE ....30 to 15,000Hz  $\pm_{-3.0}^{+0.5}$ dB

ANTENNA INPUT IMPEDANCE  
 .....300Ω balanced,  
 75Ω unbalanced

## <AM>

TUNING RANGE.....535 to 1,605kHz

SENSITIVITY (bar Antenna) ..53dB/m at 1MHz

SELECTIVITY .....better than 30dB at 1MHz

IMAGE FREQUENCY REJECTION  
 .....better than 80dB/m at 1MHz

IF REJECTION .....better than 80dB/m at 1MHz

## OTHERS

### SEMICONDUCTORS

TRANSISTORS .....35

DIODES .....25

FET .....1

ICs .....11

ZENER DIODES .....3

### POWER REQUIREMENTS

VOLTAGE .....100, 117, 220, 240V 50/60Hz

CONSUMPTION .....160W (rated)

DIMENSIONS .....480mm (18 $\frac{15}{16}$ " ) W  
 135mm (5 $\frac{3}{8}$ " ) H  
 300mm (11 $\frac{13}{16}$ " ) D

WEIGHT .....13.2kg (29.1 lbs.) net  
 15.1kg (33.3 lbs.) Packed

\* Design and specifications subject to change without notice for improvements.

## 2. BLOCK DIAGRAM AND VALUE OF EACH LEVEL

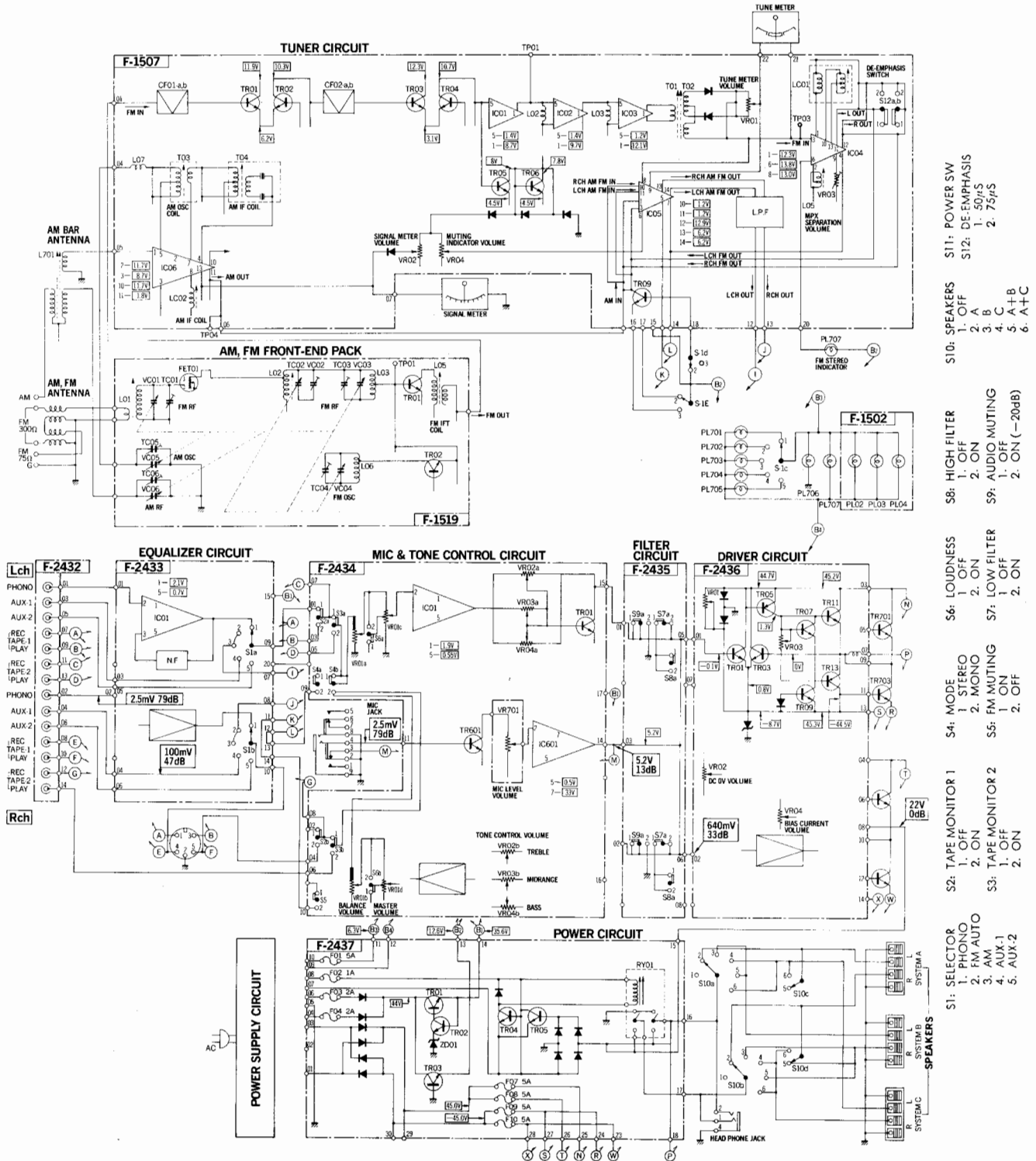

### Conditions of Level Measuring

\*Value of each level in block diagram was measured by the followings.

1. MASTER VOLUME control .....Maximum
2. BASS, TREBLE, BALANCE volume control ....Center
3. Input ....PHONO 2.5mV 1kHz Sine Wave  
AUX 100mV 1kHz Sine Wave

(output impedance of 600Ω at an audio oscillator)

4. Output ....22V (60W) 8Ω

**Note:** Each voltage value is for reference and measured by a VTVM. In some recorders, the actual voltage value is in minor difference from the reference value.

# 3. ALIGNMENTS AND ADJUSTMENTS

## Abbreviation

### Equipment

AM FM Generator Oscilloscope ..... Genescope  
 AM Standard Signal Generator..... AM SSG  
 FM Standard Signal Generator..... FM SSG  
 FM Stereo Generator ..... Stereo SG  
 Oscilloscope..... Scope  
 Audio Oscillator ..... Audio Osc.  
 Distortion Meter ..... Dist. Meter

### Others

Clockwise ..... CW.  
 Counterclockwise ..... CCW.  
 Antenna ..... ANT.  
 Modulation ..... MOD.

## 3-1. Driver Circuit Board Adjustment (See Figs. 3-1, 3-2 and 3-3)

- Note.** 1. Master Volume .....Minimum  
 2. Speaker Selector .....SYSTEM (A)  
 3. Make the SP terminals free (no load).  
 4. Confirm the AC Power Supply voltage.  
 5. After adjustment, run the unit for more than 5 minutes, then check and readjust necessary.  
 6. Room temperature should be 18~28° (65~83°F) for bias current adjustment.
- ※ Before adjustment of bias current, set VR03 and VR04 as follows.  
 1) Turn VR04 (R-ch) fully counterclockwise (The bias current is minimum).  
 2) Turn VR03 (L-ch) fully clockwise (The bias current is minimum).

STEP	SUBJECT	EQUIPMENT	MEASURE OUTPUT	ADJUST	ADJUST FOR	CONDITION
1	DC 0V L-ch	DC volt meter	Speaker terminal L-ch (Fig. 3-1)	F-2436 VR01 (Fig. 3-3)	0V ±10mV	◦ Step down meter's range accordingly ◦ Change leads polarity if meter swings backward
2	DC 0V R-ch	Same as above	Speaker terminal R-ch (Fig. 3-1)	F-2436 VR02 (Fig. 3-3)	Same as above	Same as above
3	Bias current L-ch	DC milliammeter	F-2437 F07 (Fig. 3-2)	F-2436 VR03 (Fig. 3-3)	30 ±1mA	◦ Step down meter's range accordingly
4	Bias current R-ch	Same as above	F-2437 F08 (Fig. 3-2)	F-2436 VR04 (Fig. 3-3)	Same as above	Same as above

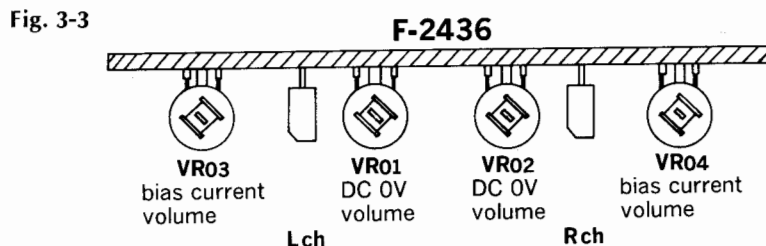
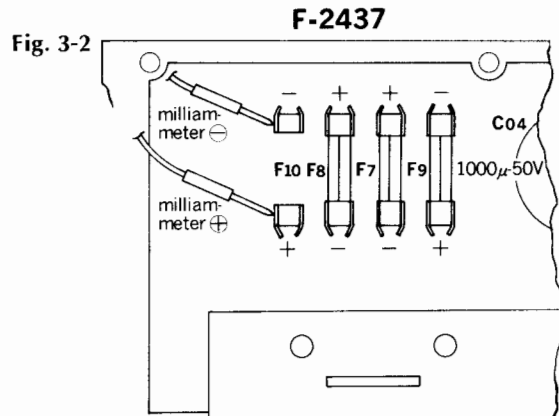
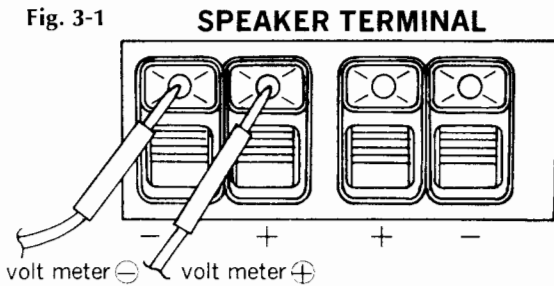

### 3-2. FM IF Alignment (See Figs. 3-7, 3-8, 3-9 and 3-10 on page 8)

- Note.** 1. Selector.....FM AUTO  
 2. Output level of genescope .....After attenuator  
 3. Sweepwidth.....1.5~2cm/150kHz  
 4. Frequency band .....9.5~11.5MHz  
 5. Connection .....Connect the output of genescope to TP. 01 through 100pF ceramic capacitor  
 6. FM MUTING switch .....OFF

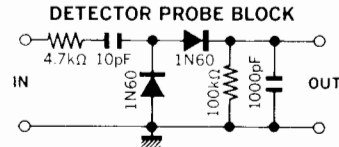
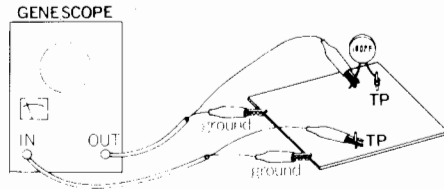



STEP	SUBJECT	FEED SIGNAL		MEASURE OUTPUT	ADJUST	ADJUST FOR	CONDITION
		FROM	TO				
1	IF coil	Output 65dB Genescope	TP. 01 (F-1519) (Fig. 3-9)	TP01 (Fig. 3-10) Use Detector Probe	L05 (Fig. 3-8)	Max. IF wave-form 1 as Fig. 3-7	
2	Discriminator coil	Same as above	Same as above	TP03 (Fig. 3-10) Direct from Genescope	T01 (Fig. 3-10) T02 (Fig. 3-10)	Max. linearity of S curve Set the center of S curve to center of wave-form 1 & 2 as Fig. 3-7	

### 3-3. FM Dial Calibration, Mono Distortion and RF Alignment (See Figs. 3-8, 3-9 and 3-10 on page 8)

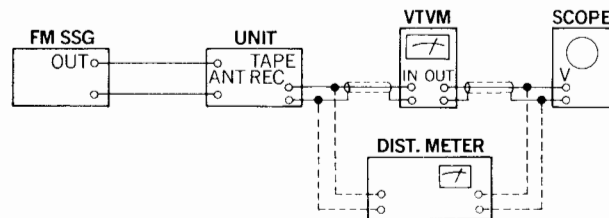
- Note:** 1. Selector.....FM AUTO  
 2. Confirm start point of dial pointer before alignment.  
 3. FM MUTING switch .....OFF

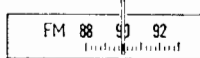
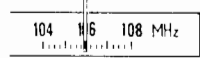

STEP	SUBJECT	FEED SIGNAL		MEASURE OUTPUT	ADJUST	ADJUST FOR	CONDITION
		FROM	TO				
1	90MHz Dial Calibration	90MHz ANT input 60dB 400Hz (100% MOD) FM SSG	ANT terminal 300Ω	REC OUT L or R-ch VTVM & Scope	L06 (Fig. 3-8)	Max. output	◦Set Dial on 90MHz 
2	106MHz Dial Calibration	106MHz ANT input 60dB 400Hz (100% MOD) FM SSG	Same as above	Same as above	Trimmer TC04 (Fig. 3-8)	Same as above	◦Set Dial on 106MHz 
3	Confirm 98MHz Dial Calibration	98MHz ANT input 60dB 1kHz (100% MOD) FM SSG	Same as above	Same as above		Confirm 98MHz Dial Calibration	◦If not, repeat from Steps 1, 2
4	90MHz RF Adj.	90MHz ANT input 50dB 400Hz (100% MOD) FM SSG	Same as above	Same as above	L01, L02, L03 (Fig. 3-8)	Max. output	◦Tune FM SSG (Max. indication of Signal Meter)

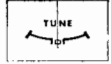
STEP	SUBJECT	FEED SIGNAL		MEASURE OUTPUT	ADJUST	ADJUST FOR	CONDITION
		FROM	TO				
5	106MHz RF Adj.	106MHz ANT input 50dB 400Hz (100% MOD) FM SSG	Same as above	Same as above	Trimmer TC01, TC02 TC03 (Fig. 3-8)	Same as above	Same as above
6	Distortion	98MHz ANT input 66dB 400Hz (100% MOD) FM SSG	Same as above	REC OUT L or R-ch Dist. meter & Scope	T02 (Fig. 3-8)	Min. distortion	Same as above
7	Signal meter Volume	98MHz ANT input 80dB 400Hz (100% MOD) FM SSG	Same as above	Signal meter	VR02 (Fig. 3-10)	4.3 on meter 	
8	Tune meter Volume	98MHz ANT input 60dB 400Hz (100% MOD) FM SSG	Same as above	Tune meter	VR01 (Fig. 3-10)	Center on meter 	

### 3-4. MPX Alignment (See Figs. 3-8 and 3-10 on page 8)

- Note:** 1. Selector .....FM AUTO  
2. FM MUTING switch.....OFF

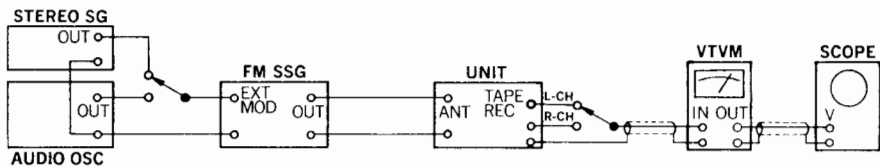

STEP	SUBJECT	FEED SIGNAL		MEASURE OUTPUT	ADJUST	ADJUST FOR	CONDITION
		FROM	TO				
1	19kHz coil	98MHz ANT input 60dB FM SSG Pilot 19kHz (10% MOD) L-ch 1kHz (45% MOD) R-ch (0% MOD) Stereo SG	ANT terminal 300Ω	REC OUT L-ch VTVM & Scope	L05 (Fig. 3-8)	Max. output	◦ Tune FM SSG (Max. indication of signal meter)
2	Separation	Same as above	Same as above	REC OUT R-ch VTVM & Scope	VR03 (Fig. 3-10)	Min. output	
3	Confirm Separation	98MHz ANT input 60dB FM SSG Pilot 19kHz (10% MOD) L-ch (0% MOD) R-ch 1kHz (45% MOD) Stereo SG	Same as above	REC OUT L-ch VTVM & Scope		Min. output	◦ If less than 40dB, adjust VR03
4	Indicator (Lighting level) Muting level	98MHz ANT input 32dB FM SSG Pilot 19kHz (10% MOD) Stereo SG L-ch (0% MOD) R-ch (45% MOD)	Same as above	Stereo indicator lamp REC OUT R-ch VTVM & Scope	VR04 (Fig. 3-10)	Lighting Point, Muting Point 32dB	◦ Tune FM SSG (Max. indication of signal meter)

### 3-5. AM IF, Dial Calibration, RF Alignment (See Figs. 3-5, 3-6, 3-8 and 3-10 on page 8)

- Note:** 1. Selector.....AM  
 2. Confirm start point of dial pointer before alignment.  
 3. In case of using loop antenna, increase output of AM SSG for 26dB than bar antenna's direct input as it attenuates input sensitivity for 26dB (See Fig. 3-4).

Fig. 3-4

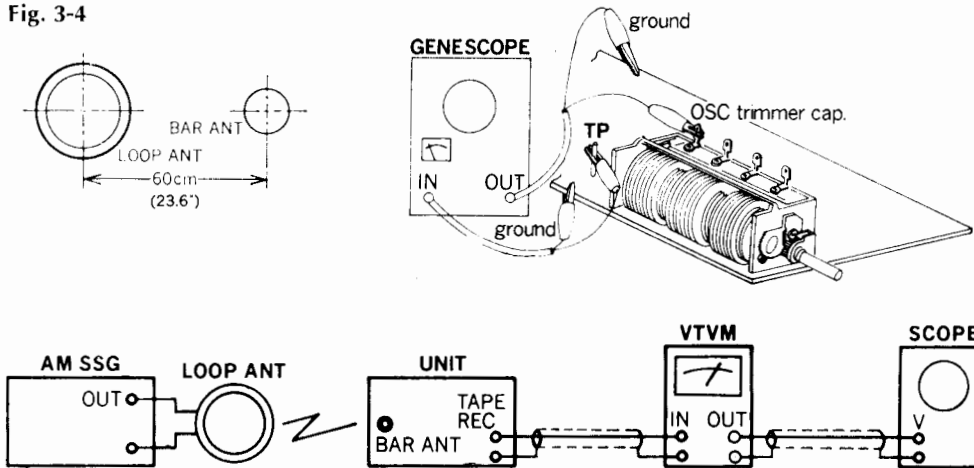

STEP	SUBJECT	FEED SIGNAL		MEASURE OUTPUT	ADJUST	ADJUST FOR	CONDITION
		FROM	TO				
1	IF coil	Output 70dB Genescope	OSC trimmer cap. TC05 (Fig. 3-8)	TP04 (Fig. 3-10)	T04 (Fig. 3-10)	Max. IF wave- form (Fig. 3-5)	
2	IF coil	Output 60dB Genescope	Same as above	Same as above	LC02 (Fig. 3-10)	Max. IF wave- form (Fig. 3-6)	
3	IF coil	Output 70dB Genescope	Same as above	Same as above		Max. IF wave- form (Fig. 3-6)	◦ If not, readjust T04 & LC02 slightly
4	535kHz Dial Calibra- tion	535kHz ANT input 86dB 400Hz (30% MOD) AM SSG Use loop ANT	Bar ANT	REC OUT L or R-ch VTVM & Scope	T03 (Fig. 3-10)	Max. output	◦ If broadcasting sta- tion is near, it might be used
5	1400kHz Dial Calibra- tion	1400kHz ANT input 86dB 400Hz (30% MOD) AM SSG Use loop ANT	Same as above	Same as above	Trimmer TC05 (Fig. 3-8)	Same as above	Same as above
6	Confirm 1000kHz Dial Calibra- tion	1000kHz ANT input 86dB 400Hz (30% MOD) AM SSG Use loop ANT	Same as above	Same as above		Confirm 1000kHz Dial Calibration	◦ If not, repeat from Step 4, 5
7	600kHz RF Adj.	600kHz ANT input 76dB 400Hz (30% MOD) AM SSG Use loop ANT	Same as above	Same as above	Bar ANT L701	Max. output	
8	1400kHz RF Adj.	1400kHz ANT input 96dB 400Hz (30% MOD) AM SSG Use loop ANT	Same as above	Same as above	Trimmer TC06 (Fig. 3-8)	Same as above	



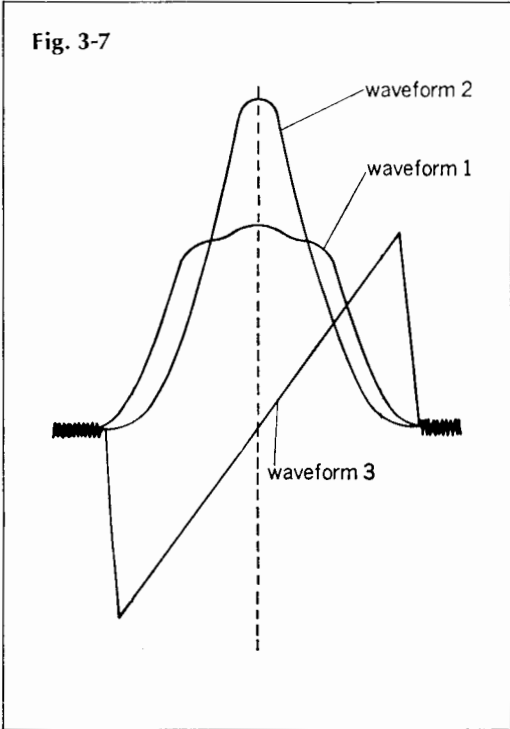
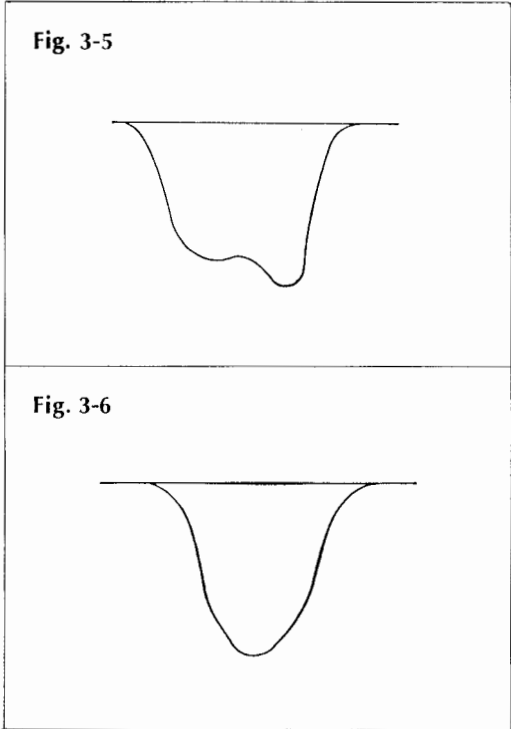

**Fig. 3-8**

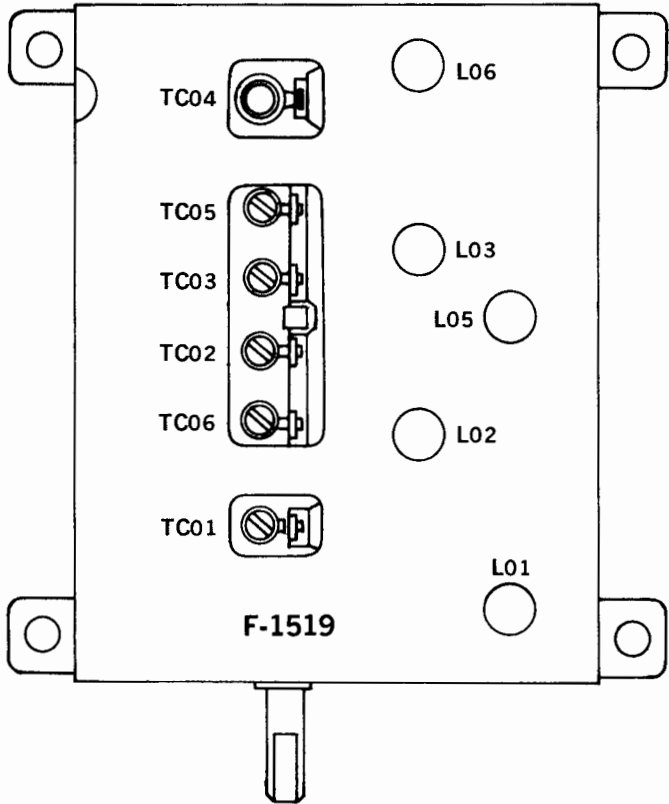

Fig. 3-9

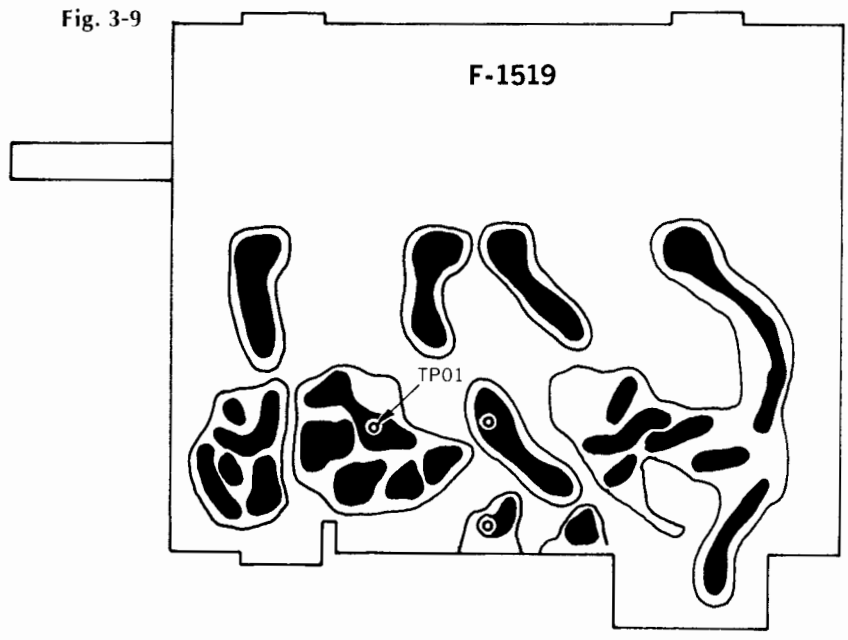
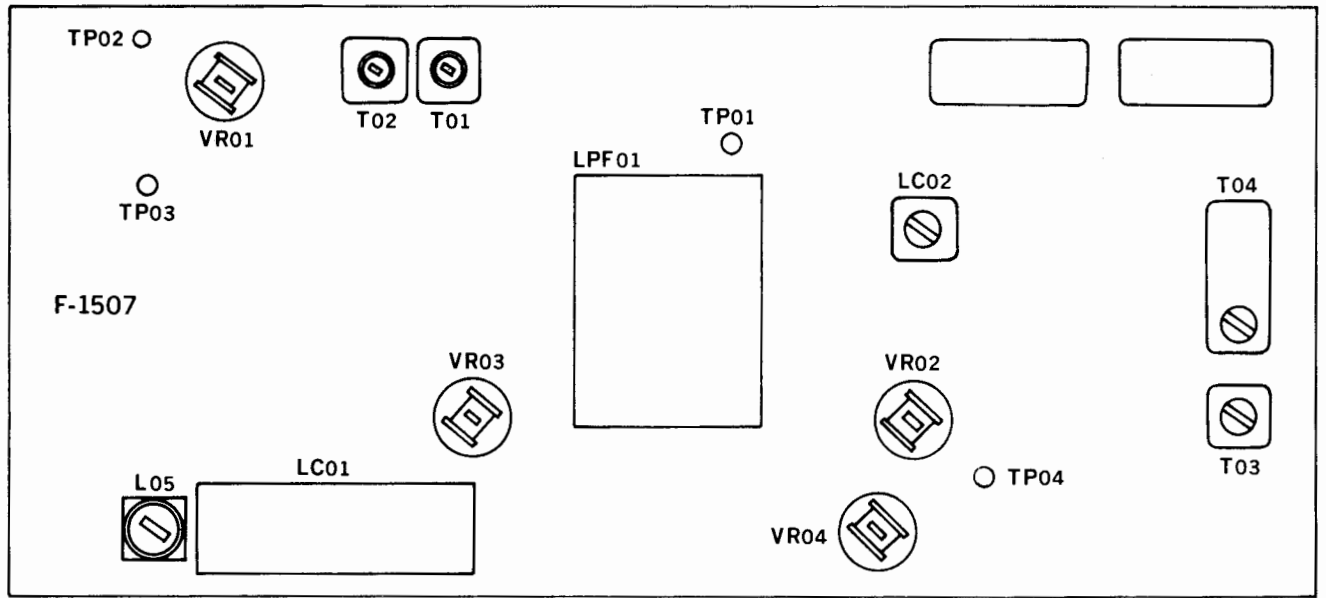

Fig. 3-10



## 4. TROUBLESHOOTING CHART

### 4-1. Troubleshooting on Power Supply Section

Symptom	Check Point	Cause & What to Do
<b>1-1. No power supplied to each section</b>		
1. Each lamp not lighted		1. Imperfect contact of power supply plug 2. Defective power switch, S11 3. Imperfect contact of voltage selector, PU01 4. Power fuse F701 open 5. Defective power transformer, PT01
2. Each lamp lighted		
1) +13.5V not supplied to terminal [13] on F-2437		6. Fuse F03, F04 on F-2437 open 7. Defective diode D02, D03 on F-2437 8. Defective transistor TR03 on F-2437
2) +35.6V not supplied to terminal [14] on F-2437		9. Defective transistor TR01~TR02 on F-2437 10. Defective zener diode ZD01 on F-2437
3) +45.0V not supplied to terminal [25], [26] and -45.0V not supplied to terminal [27], [28] on F-2437		11. Defective diode D04, D05 on F-2437 12. Quick acting fuse F07~F10 on F-2437 open

### 4-2. Troubleshooting on Audio Section

#### 2-1. Trouble on main circuit

1. Main circuit inoperative		
1) Quick acting fuse open		1. Shorted speaker terminals by speaker wire 2. Power transistor TR701~TR704 short 3. Defective transistor TR05~TR06, TR11~TR14 on F-2436
2) Quick acting fuse not open		4. Defective transistor TR01~TR04, TR07~TR10 on F-2436
2. DC Bias current (+30mA) not adjustable		5. Defective volume VR03, VR04 on F-2436 6. Defective transistor TR07~TR10 on F-2436
3. Center voltage (0V) not adjustable		7. Defective volume VR01, VR02 on F-2436 8. Defective transistor TR01~TR04 on F-2436 9. Defective diode D01~D04 on F-2436

#### 2-2. Filter inoperative

1. Low filter inoperative		10. Defective low filter switch, S7 on F-2435
2. High filter inoperative		11. Defective high filter switch, S8 on F-2435
3. Audio muting inoperative		12. Defective audio muting switch, S9 on F-2435

Symptom	Check Point	Cause & What to Do
<b>2-3. Tone control circuit inoperative</b>	—	13. Defective tape monitor switch, S2, S3 on F-2434
		14. Defective IC01, IC02 on F-2434
		15. Defective transistor TR01, TR02 on F-2434
<b>2-4. Mic inoperative</b>	—	16. Shorted MIC jack
		17. Defective IC601 on F-2434
		18. Defective transistor TR601 on F-2434
<b>2-5. Phono inoperative</b>	—	19. Shorted input terminal of phono on F-2432
		20. Defective selector switch S1 on F-2433
		21. Defective IC01, IC02 on F-2433
<b>2-6. Protector circuit inoperative</b> (In case the center voltage on power section is over $\pm 2V$ )	—	22. Fuse, F02 open on F-2437
		23. Defective diode, D01, D06~D10 on F-2437
		24. Defective transistor, TR04, TR05 on F-2437
		25. Defective relay Ry01 on F-1500

### 4-3. Troubleshooting on Tuner Section

<b>3-1. Both AM and FM reception inoperative</b>	—	1. $+12.6V$ not supplied to points <span style="border: 1px solid black; padding: 2px;">15</span> , <span style="border: 1px solid black; padding: 2px;">16</span> , <span style="border: 1px solid black; padding: 2px;">17</span> on F-1507
		2. Defective IC05 on F-1507
		3. Defective low pass filter, LPF01 on F-1507

### 3-2. FM reception only inoperative

\* Before check, set FM MUTING switch to OFF

#### 1. FM inoperative

Signal meter inoperative (Meter circuit on F-1507 is normally operative)

- 4. Incorrect adjustment of front-end pack, F-1519
- 5. Defective front-end pack, F-1519
- 6. Defective transistor TR01~TR04 on F-1507
- 7. Defective ceramic filter, CF-1~CF-2 on F-1507

Signal meter operative

- 8. Defective IC01~IC03 on F-1507
- 9. Defective diode, D01~D02 on F-1507
- 10. Discriminator coil, T01, T02 on F-1507 defective or out of adjustment

#### 2. Inoperative MPX circuit

\* Confirm that FM signal supplied to test point, TP03 on F-1507

\* MPX signal including R and Lch not supplied to point 11, or 12 of IC04

- 11. Defective IC04 on F-1507

Symptom	Check Point	Cause & What to Do
3. No channel separation & no light on stereo indicator		-12. L05, LC01 on F-1507 defective or out of adjustment
		-13. Defective separation volume, VR03 on F-1507
		-14. Incorrect adjustment of muting volume, VR04 on F-1507
		-15. Defective muting volume, VR04 on F-1507
		-16. Opened indicator lamp, PL707
		-17. Defective mode switch, S4 on F-2434

### 3-3. Signal meter inoperative

\* FM or AM sound can be heard

- 18. Defective transistor, TR05~TR06 on F-1507
- 19. Defective diode, D03~D07 on F-1507
- 20. Meter volume, VR02 on F-1507 defective or out of adjustment
- 21. Defective signal meter

### 3-4. FM muting function inoperative

1. FM reception inoperative when setting muting switch to ON

- 22. Poor sensitivity due to incorrect tracking, IF adjustment
- 23. Incorrect adjustment of muting volume, VR04 on F-1507

2. FM muting function inoperative

- 24. Defective muting switch, S5 on F-1507
- 25. Defective muting volume, VR04 on F-1507

### 3-5. AM reception inoperative

Signal meter inoperative (AM sound can be heard)

\* Output appears on test point, TP04 on F-1507

- 26. Shorted transistor, TR09 on F-1507
- 27. Defective IC05 on F-1507
- 28. Defective low pass filter, LPF01 on F-1507

Signal meter inoperative (AM sound can not be heard)

- 29. Defective IC06 on F-1507
- 30. Bar antenna coil, L701 opened or out of adjustment
- 31. Incorrect tracking and IF adjustment
- 32. Opened OSC. coil T03, IF coil T04 or LC03 on F-1507

# 5. PARTS LOCATIONS AND PARTS LISTS

## 5-1. F-1507 Tuner Circuit Board (Stock No. 7520990 Complete Circuit Board F-1507)

### Conductor Side

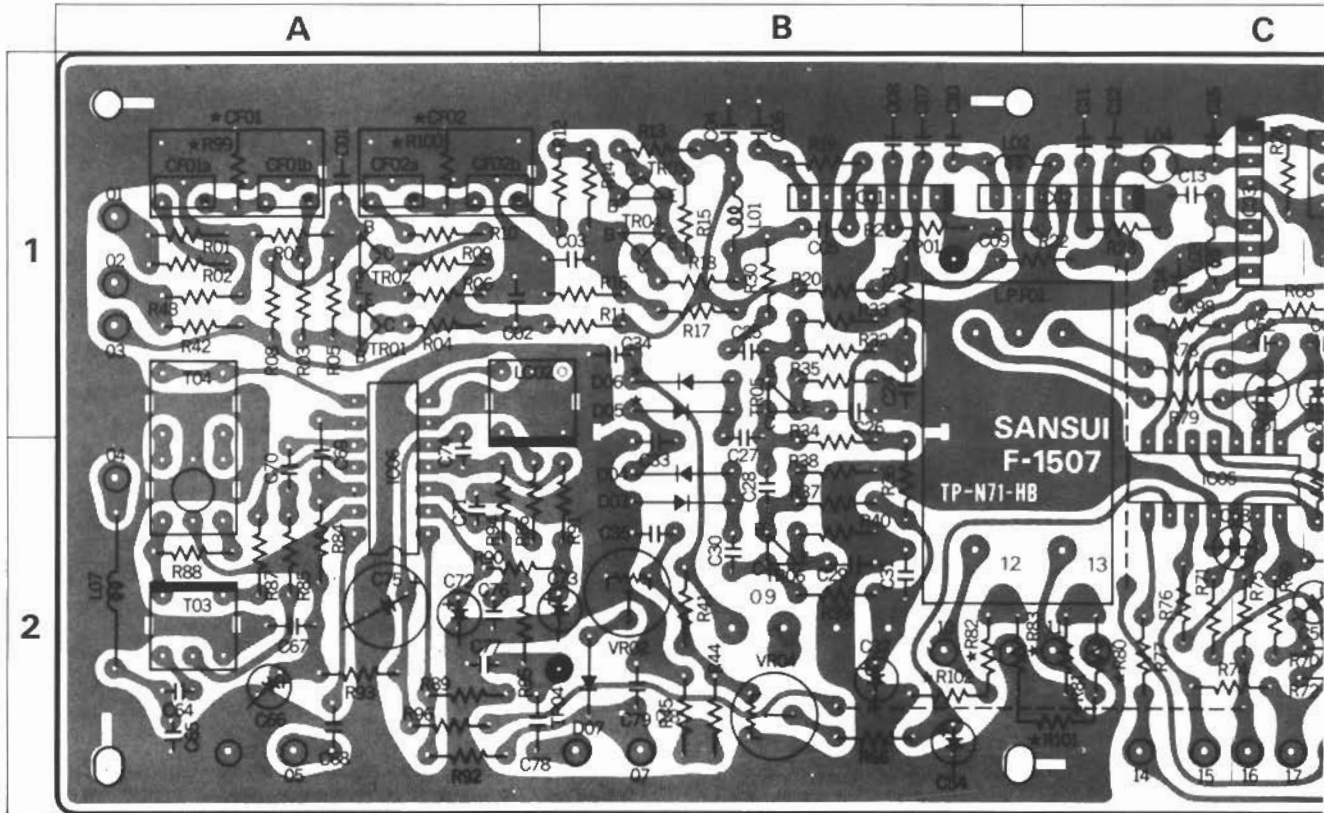

### Parts List

Parts No.	Stock No.	Description	Position	Parts No.	Stock No.	Description	Position
TR01	0306112, 3	2SC738(C, D)	1 A	L01	4900200	10 $\mu$ H	1 B
TR02	0306112, 3	2SC738(C, D)	1 A	L02	4900200	10 $\mu$ H	1 B
TR03	0306112, 3	2SC738(C, D)	1 B	L03	4900200	10 $\mu$ H	1 C
TR04	0306112, 3	2SC738(C, D)	1 B	L04	4900100	3.3 $\mu$ H	1 C
TR05	0306112, 3	2SC738(C, D)	1 B	L05	4240720	19kHz Coil	2 D
TR06	0306112, 3	2SC738(C, D)	2 B	L07	4290011	3.5 $\mu$ H Peaking Coil	2 A
TR09	0305731, 2	2SC711(E, F)	2 C	LC01	4240710	MPX Coil Block	2 D
IC01	0360120	$\mu$ PC555H	1 B	LC02	4230620	AM IF Coil	1 A, B
IC02	0360120	$\mu$ PC555H	1 B, C	T01	4235750	FM Discriminator Coil	1 C
IC03	0360120	$\mu$ PC555H	1 C	T02	4235760		1 C
IC04	0360080	HA1120	2 D	T03	4220550	AM OSC Coil	2 A
IC05	0360140	HA1149	2 C	T04	0910270	Ceramic Filter	
IC06	0360150	HA1151	1, 2 A	LPF01	0910210	BL-11 Low Pass Filter	1, 2 B C
D01	0311060	1N60P	1 D	VR01	1035150	22k $\Omega$ (B) Tune Meter Volume	1 D
D02	0311060	1N60P	1 D	VR02	1035170	47k $\Omega$ (B) Signal Meter Volume	2 B
D03	0310330, 1	1N60	2 B	VR03	1035070	1k $\Omega$ (B) MPX Separation Volume	2 C
D04	0310330, 1	1N60	2 B	VR04	1035190	100k $\Omega$ (B) Muting, FM Indicator Volume	2 B
D05	0310330, 1	1N60	1 B				
D06	0310330, 1	1N60	1 B				
D07	0310330, 1	1N60	2 B				
CF01a,b	1107008	SFG10.7MA-6	1 A	S12	1110270	DE-EMPHASIS switch	
CF02a,b	1107008	SFG10.7MA-6	1 A				

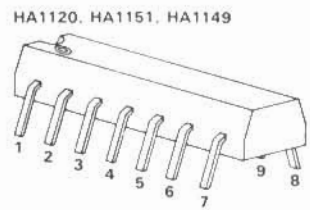
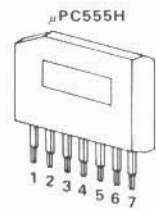
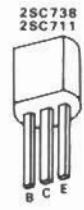
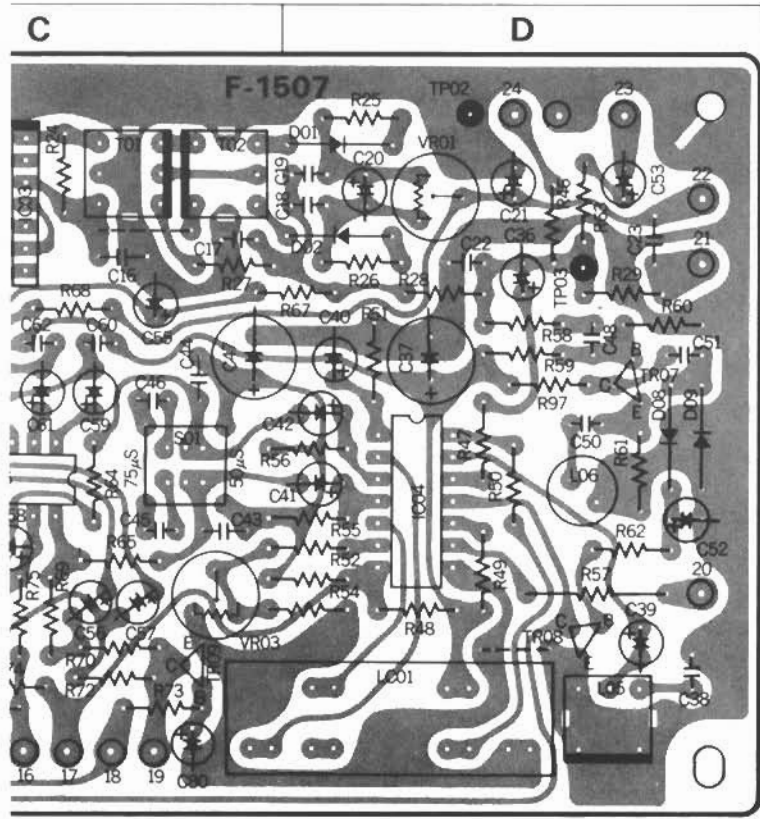

Parts No.	Stock No.	Description	Position
C01	0657223	0.022 $\mu$ F	1 A
C02	0657223	0.022 $\mu$ F	1 A
C03	0657223	0.022 $\mu$ F	1 B
C04	0657223	0.022 $\mu$ F	1 B
C05	0657223	0.022 $\mu$ F	1 B
C06	0657223	0.022 $\mu$ F	1 B
C07	0657223	0.022 $\mu$ F	1 B
C08	0657223	0.022 $\mu$ F	1 B
C09	0657223	0.022 $\mu$ F	1 B, C
C10	0657223	0.022 $\mu$ F } 50V C.C.	1 B
C11	0657223	0.022 $\mu$ F	1 C
C12	0657223	0.022 $\mu$ F	1 C
C13	0657223	0.022 $\mu$ F	1 C
C14	0657223	0.022 $\mu$ F	1 C
C15	0657223	0.022 $\mu$ F	1 C
C16	0657223	0.022 $\mu$ F	1 C
C17	0660101	100pF	1 C
C18	0660101	100pF	1 D
C19	0660101	100pF	1 D
C20	0512100	10 $\mu$ F 16V E.C.	1 D
C21	0513479	4.7 $\mu$ F	1 D
C22	0660101	100pF	1 D
C23	0657223	0.022 $\mu$ F } 50V C.C.	1 D
C24	0657223	0.022 $\mu$ F	1 B
C25	0661470	47pF	1 B

Parts No.	Stock No.	Description	Position
C26	0657223	0.022 $\mu$ F	1 B
C27	0661330	33pF	2 B
C28	0661470	47pF	2 B
C29	0657223	0.022 $\mu$ F } 50V C.C.	2 B
C30	0661470	47pF	2 B
C31	0657223	0.022 $\mu$ F	2 B
C32	0512100	10 $\mu$ F 16V E.C.	2 B
C33	0657223	0.022 $\mu$ F } 50V C.C.	2 B
C34	0657223	0.022 $\mu$ F	1 B
C35	0657223	0.022 $\mu$ F	2 B
C36	0515229	2.2 $\mu$ F 50V E.C.	1 D
C37	0512101	100 $\mu$ F 16V E.C.	1 D
C38	0629001	6800pF 50V P.C.	2 D
C39	0513479	4.7 $\mu$ F } 25V E.C.	2 D
C40	0513479	4.7 $\mu$ F	1 D
C41	0515109	1 $\mu$ F } 50V M.C.	2 D
C42	0515109	1 $\mu$ F	1 D

— Abbreviations —

- C.R. : Carbon Resistor
- S.R. : Solid Resistor
- Ce.R. : Cement Resistor
- M.R. : Metallized Film Resistor
- M.C. : Mylar Capacitor
- E.C. : Electrolytic Capacitor
- BP.E.C.: Bi-Polar Electrolytic Capacitor
- C.C. : Ceramic Capacitor
- Mi.C. : Mica Capacitor
- O.C. : Oil Capacitor
- P.C. : Polystyrene Capacitor
- T.C. : Tantalum Capacitor

F-1507 Parts List

Parts No.	Stock No.	Description	Position	Parts No.	Stock No.	Description	Position	
C43	0600157	0.015 $\mu$ F	50V M.C.	R36	0113220	22 $\Omega$	2 B	
C44	0600157	0.015 $\mu$ F		1 C	R37	0113223	22k $\Omega$	2 B
C45	0600686	0.0068 $\mu$ F	50V M.C.	R38	0113183	18k $\Omega$	2 B	
C46	0600686	0.0068 $\mu$ F		2 C	R39	0113102	1k $\Omega$	2 B
C47	0512101	100 $\mu$ F	16V E.C.	R40	0113102	1k $\Omega$	2 B	
C53	0512100	10 $\mu$ F	16V E.C.	R41	0113222	2.2k $\Omega$	2 B	
C54	0515109	1 $\mu$ F	50V E.C.	R42	0113104	100k $\Omega$	1 A	
C55	0515339	3.3 $\mu$ F		1 C	R43	0113333	33k $\Omega$	1 A
C56	0515109	1 $\mu$ F		2 C	R47	0113562	5.6k $\Omega$	1/4W S.R.
C57	0515109	1 $\mu$ F		2 C	R48	0113479	4.7 $\Omega$	
C58	0512100	10 $\mu$ F	16V E.C.	R49	0113334	330k $\Omega$	2 D	
C59	0519101	1 $\mu$ F	50V E.C.	R50	5113181	180 $\Omega$	2 D	
C60	0601686	0.0068 $\mu$ F	50V M.C.	R51	0113472	4.7k $\Omega$	1 D	
C61	0519101	1 $\mu$ F	50V E.C.	R52	0113151	150 $\Omega$	2 D	
C62	0601686	0.0068 $\mu$ F	50V M.C.	R54	0113101	100 $\Omega$	2 D	
C64	0620361	360pF	50V P.C.	R55	0113392	3.9k $\Omega$	2 D	
C65	0669215	15pF	50V C.C.	R56	0113392	3.9k $\Omega$	2 D	
C66	0512100	10 $\mu$ F	16V E.C.	R57	0171181	180 $\Omega$	1W M.R.	
C67	0657223	0.022 $\mu$ F	50V C.C.	R63	0113471	470 $\Omega$		1 D
C68	0657223	0.022 $\mu$ F	50V C.C.	R64	0113332	3.3k $\Omega$	2 C	
C69	0657223	0.022 $\mu$ F		2 A	R65	0113332	3.3k $\Omega$	2 C
C70	0601107	0.01 $\mu$ F		2 A	R66	0113104	100k $\Omega$	2 B
C71	0601106	0.001 $\mu$ F	50V M.C.	R67	0113223	22k $\Omega$	1 C, D	
C72	0515109	1 $\mu$ F		2 A	R68	0113223	22k $\Omega$	1 C
C73	0515339	3.3 $\mu$ F	50V E.C.	R69	0113822	8.2k $\Omega$	2 C	
C74	0601107	0.01 $\mu$ F	50V M.C.	R70	0113123	12k $\Omega$	2 C	
C75	0512101	100 $\mu$ F	16V E.C.	R71	0113822	8.2k $\Omega$	2 C	
C76	0601107	0.01 $\mu$ F	50V M.C.	R72	0113123	12k $\Omega$	2 C	
C77	0601226	0.0022 $\mu$ F		2 A	R73	0113472	4.7k $\Omega$	2 C
C78	0601227	0.022 $\mu$ F		2 A	R74	0113222	2.2k $\Omega$	2 C
C79	0657223	0.022 $\mu$ F		2 B	R75	0113472	4.7k $\Omega$	2 C
C81	0515339	33 $\mu$ F	50V E.C.	R76	0113222	2.2k $\Omega$	2 C	
R04	0113151	150 $\Omega$	1 A	R77	0113103	10k $\Omega$	2 C	
R05	0113391	390 $\Omega$	1 A	R78	0113102	1k $\Omega$	1 C	
R06	0113681	680 $\Omega$	1 A	R79	0113102	1k $\Omega$	1 C	
R07	0113153	15k $\Omega$	1 A	R84	0113392	3.9k $\Omega$	1/4W S.R.	
R08	0113103	10k $\Omega$	1 A	R85	0113100	10 $\Omega$		2 A
R09	0113471	470 $\Omega$	1 A	R86	0113101	100 $\Omega$	2 A	
R11	0113479	4.7 $\Omega$	1 B	R87	0113100	10 $\Omega$	2 A	
R13	0113151	150 $\Omega$	1 B	R88	0113224	220k $\Omega$	2 A	
R14	0113391	390 $\Omega$	1 B	R89	0113122	1.2k $\Omega$	2 A	
R15	0113221	220 $\Omega$	1 B	R90	0113103	10k $\Omega$	2 A	
R16	0113562	5.6k $\Omega$	1 B	R91	0113103	10k $\Omega$	2 B	
R17	0113102	10k $\Omega$	1 B	R92	0113122	1.2k $\Omega$	2 A	
R18	0113151	150 $\Omega$	1 B	R93	0113151	150 $\Omega$	2 A	
R19	0113102	1k $\Omega$	1 B	R94	0113182	1.8k $\Omega$	2 A	
R20	0113479	4.7 $\Omega$	1/4W S.R.	R95	0113183	18k $\Omega$	2 A	
R21	0113102	1k $\Omega$		1 B	R96	0113101	100 $\Omega$	2 A
R22	0113479	4.7 $\Omega$	1 B, C	R98	0113473	47k $\Omega$	1 A	
R23	0113102	1k $\Omega$		1 C	R99	0113681		680 $\Omega$
R24	0113682	6.8k $\Omega$	1 C	R100	0113681	680 $\Omega$	1 A	
R25	0113102	1k $\Omega$	1 D	R101	0113332	3.3k $\Omega$	2 B, C	
R26	0113102	1k $\Omega$	1 D	R102	0113332	3.3k $\Omega$	2 B	
R27	0113101	100 $\Omega$	1 C	R103	0113103	10k $\Omega$	2 A	
R28	0113471	470 $\Omega$	1 D	R104	0113223	22k $\Omega$	1 D	
R29	0113393	39k $\Omega$	1 D	R105	0113223	22k $\Omega$		
R30	0113152	1.5k $\Omega$	1 B		2260010	Test Pin		
R31	0113220	22 $\Omega$	1 B					
R32	0113333	33k $\Omega$	1 B					
R33	0113822	8.2k $\Omega$	1 B					
R34	0113102	1k $\Omega$	2 B					
R35	0113391	390 $\Omega$	1 B					



## 5-2. F-1519C FM Pack (Stock No. 7510650 Complete Circuit Board F-1519C)

### Conductor Side

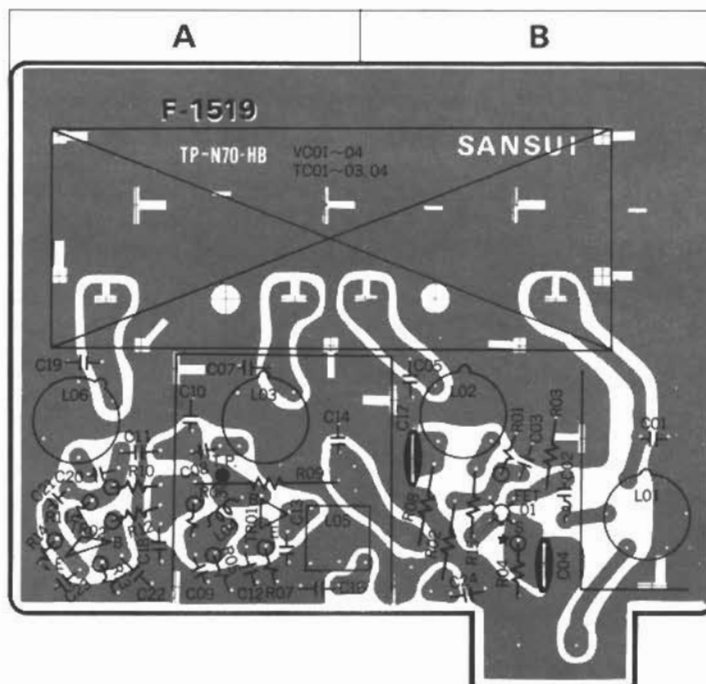

### Parts List

Parts No.	Stock No.	Description	Position
TR01	0305800, 1	2SC1047(A, B) } Transistor	A
TR02	0305790, 1		A
FET01	0370131, 2	3SK41 (K, L) FET	B
L01	4200640	Antenna Coil	B
L02	4210220	RF Coil (1)	B
L03	4210220	RF Coil (2)	A
L04	4290110	Choke Coil	A
L05	4235910	IF Coil	A, B
L06	4220430	OSC Coil	A
VC01-04	1220130	FM, AM Variable Capacitor	A, B
TC01-03			A, B
TC04	1230090	FM OSC Trimmer	A, B
C01	0669342	5.6pF	B
C02	0657102	1000pF	B
C03	0657223	0.022μF	B
C04	0659015	2200pF	B
C05	0669345	10pF	B
C06	0679023	0.39pF	500V Gimmick Capacitor
C07	0669345	10pF	A
C08	0669210	10pF	A
C09	0657102	1000pF	A
C10	0661220	22pF	A
C11	{0669003 0669202}	2.2pF	A
C12	0657223	0.022μF	50V C.C.
C13	0660121	120pF	A
C14	0657223	0.022μF	A
C16	0660331	330pF	A
C17	0659015	2200pF	B
C18	0657223	0.022μF	A
C19	0669350	15pF	A

Parts No.	Stock No.	Description	Position
C20	0657102	1000pF	A
C21	0669369	8.2pF	A
C22	0657223	0.022μF	50V C.C.
C23	{0661220 0669221}	22pF	A
C24	0657223	0.022μF	B
R01	0106105	1MΩ	1/4W C.R. (E.L.R.)
R02	0113104	100kΩ	1/4W S.R.
R03	0113104	100kΩ	B
R04	{0106101 0106151}	{100Ω 150Ω}	B
R05	0106392	3.9kΩ	1/4W C.R. (E.L.R.)
R06	0106123	12kΩ	A
R07	0106392	3.9kΩ	A
R08	0113121	120Ω	1/4W S.R.
R09	0113271	270Ω	A
R10	0106392	3.9kΩ	A
R11	0106121	120Ω	A
R12	0106682	6.8kΩ	1/4W C.R.
R13	0106222	2.2kΩ	A
R14	0106182	1.8kΩ	A
R15	0113470	47Ω	1/4W S.R.
	2260010	Test Pin	

### Abbreviations

C.R.	: Carbon Resistor	BP.E.C.:	Bi-Polar Electrolytic Capacitor
S.R.	: Solid Resistor	C.C.	: Ceramic Capacitor
Ce.R.	: Cement Resistor	Mi.C.	: Mica Capacitor
M.R.	: Metallized Film Resistor	O.C.	: Oil Capacitor
M.C.	: Mylar Capacitor	P.C.	: Polystyrene Capacitor
E.C.	: Electrolytic Capacitor	T.C.	: Tantalum Capacitor

### 5-3. F-2433 Equalizer Circuit Board

(Stock No. 7550610 Complete Circuit Board F-2433)

#### Conductor Side

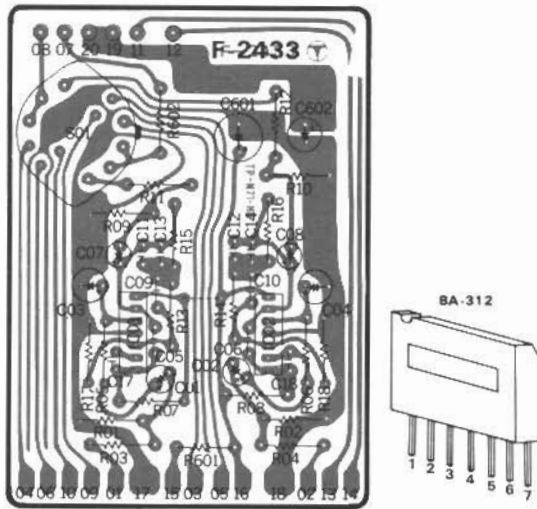

#### Parts List

Parts No.	Stock No.	Description
IC01, 02	0360190	BA-312 IC
C01, 02	0519102	3.3 $\mu$ F 50V E.C.
C03, 04	0510470	47 $\mu$ F 6.3V E.C.
C05, 06	0660470	47pF 50V C.C.
C07, 08	0519101	1 $\mu$ F 50V E.C.
C09, 10	0600107	0.01 $\mu$ F } 50V M.C.
C11, 12	0600276	0.0027 $\mu$ F }
C13, 14	0660101	100pF } 50V C.C.
C15, 16	0660221	220pF }
C601	0515161	100 $\mu$ F 50V E.C.
C602	0510221	220 $\mu$ F 6.3V E.C.
R01, 02	0107563	56k $\Omega$ } $\frac{1}{4}$ W C.R.
R03, 04	0107222	2.2k $\Omega$ }
R05, 06	0107823	82k $\Omega$ }
R07, 08	0107334	330k $\Omega$ }
R09, 10	0107334	330k $\Omega$ }
R11, 12	0107221	220 $\Omega$ }
R13, 14	0107334	330k $\Omega$ }
R15, 16	0107273	2.7k $\Omega$ }
R17, 18	0107821	820 $\Omega$ }
R601	0107333	330 $\Omega$ }
Sl(a, b)	1101600	SRME 1-2-5 SELECTOR Switch

### 5-4. F-2432 Input Terminal Board

(Complete Circuit Board F-2432)

#### Parts List

Parts No.	Stock No.	Description
C907, 908	0657473	0.047 $\mu$ F 50V C.C.
R901, 902	0107224	220k $\Omega$ }
R903, 904	0107224	220k $\Omega$ }
R905, 906	0107224	220k $\Omega$ }
R907, 908	0107224	220k $\Omega$ }
	2430250	1P Input Terminal

### 5-5. F-2434 Tone Control Circuit Board

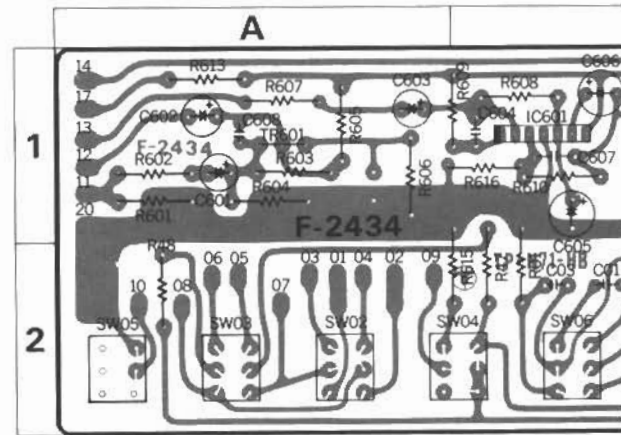

#### Parts List

Parts No.	Stock No.	Description	Position	
TR01, 02	{ 0306070, 1 0306011, 2 0305880, 1	{ 2SC1313 (R, F, G) 2SC1222 (E, F) 2SC1000 (GR, BL)	Transistor 1C, D, 1D	
TR601	{ 0306070, 1 0306011, 2 0305880, 1	{ 2SC1313 (R, F, G) 2SC1222 (E, F) 2SC1000 (GR, BL)		1A
IC01, 02	0360190	BA312		1C
IC601	0360190	BA312	1B	
C01, 02	0620471	470pF 50V P.C.	2B	
C03, 04	0600277	0.027 $\mu$ F 50V M.C.	2B	
C05, 06	0519101	1 $\mu$ F 50V E.C.	1C	
C07, 08	0660330	33pF 50V C.C.	1C	
C09, 10	0510101	100 $\mu$ F 6.3V E.C.	1C, 2C	
C11, 12	0519001	10 $\mu$ F 25V E.C.	1C, 1, 2C	
C13, 14	0660101	100pF 50V C.C.	1C, 1, 2C	
C15, 16	0600156	0.0015 $\mu$ F } 2C		
C17, 18	0600336	0.0033 $\mu$ F } 2C		
C19, 20	0600476	0.0047 $\mu$ F } 50V M.C.	1C, 1, 2D	
C21, 22	0600187	0.018 $\mu$ F } 2D		
C23, 24	0600187	0.018 $\mu$ F } 2D		
C25, 26	0519101	1 $\mu$ F 50V E.C.	1C, 1D	
C27, 28	0510221	220 $\mu$ F 6.3V E.C.	1C, D, 1D	
C29, 30	0519001	10 $\mu$ F 25V E.C.	1D	
C31, 32	0660330	33pF 50V C.C.	1C, 1D	
C601	0573108	0.1 $\mu$ F 25V T.C.	1A	
C602	0519106	4.7 $\mu$ F } 50V E.C.	1A	
C603	0519101	1 $\mu$ F } 50V E.C.	1A	
C604	0660330	33pF 50V C.C.	1B	
C605	0510470	47 $\mu$ F 6.3V E.C.	1B	
C606	0519106	4.7 $\mu$ F 50V E.C.	1B	
C607	0660331	330pF } 50V C.C.	1B	
C608	0660330	33pF }	1A	
C609	0515101	100 $\mu$ F 50V E.C.	1B	
C610	0513101	100 $\mu$ F 35V E.C.	1D	
R01, 02	0107183	18k $\Omega$ }	1, 2B, 2B	
R03, 04	0107222	2.2k $\Omega$ }	1B, C	
R05, 06	0107154	150k $\Omega$ }	1C	
R07, 08	0107474	470k $\Omega$ }	1C	
R09, 10	0107103	10k $\Omega$ }	$\frac{1}{4}$ W C.R.	
R11, 12	0107274	270k $\Omega$ }		
R13, 14	0107562	5.6k $\Omega$ }	1, 2C, 2C	
R15, 16	0107682	6.8k $\Omega$ }	1, 2C	
R17, 18	0107153	15k $\Omega$ }	1, 2D	

(Stock No. 7560850 Complete Circuit Board F-2434)

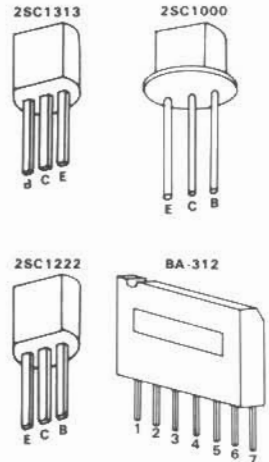
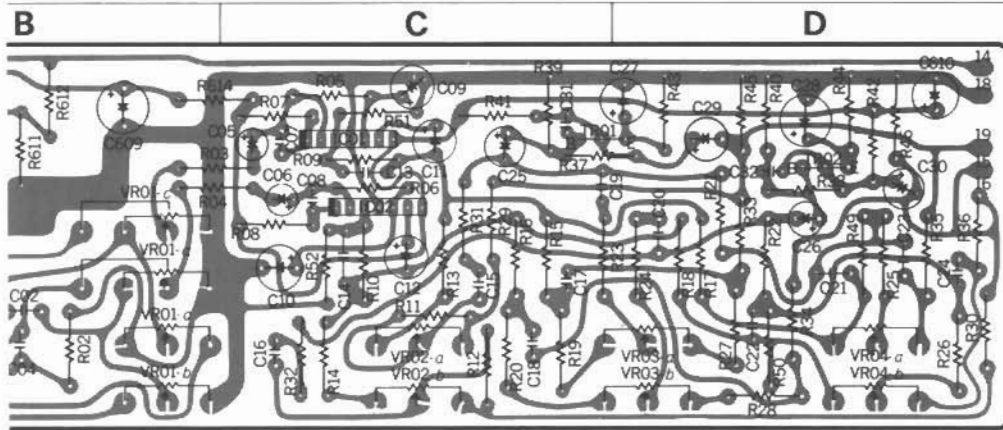

**Abbreviations**

- C.R. : Carbon Resistor
- M.C. : Mylar Capacitor
- E.C. : Electrolytic Capacitor
- C.C. : Ceramic capacitor
- P.C. : Polystyrene Capacitor
- T.C. : Tantalum Capacitor

Parts No.	Stock No.	Description	Position
R19, 20	0107562	5.6kΩ	2C
R21, 22	0107273	27kΩ	1, 2D
R23, 24	0107223	22kΩ	1, 2C, 1, 2D
R25, 26	0107222	2.2kΩ	1, 2D, 2D
R27, 28	0107562	5.6kΩ	2D
R29, 30	0107562	5.6kΩ	1, 2C, 2D
R31, 32	0107222	2.2kΩ	1, 2C, 2C
R33, 34	0107682	6.8kΩ	1, 2D, 2D
R35, 36	0107153	15kΩ	1, 2D
R37, 38	0107474	470kΩ	1C, D, 1D
R39, 40	0107224	220kΩ	1C, 1D
R41, 42	0107562	5.6kΩ	1C, 1D
R43, 44	0107331	330Ω	1D
R45, 46	0107224	220kΩ	1D
R47, 48	0107123	12kΩ	1, 2B, 2A
R49, 50	0107224	220kΩ	1, 2D, 2D
R51, 52	0107821	820Ω	1C, 1, 2C
R601	0107563	56kΩ	1A
R602	0107222	2.2kΩ	1A
R603	0107564	560kΩ	1A
R604	0107563	56kΩ	1A
R605	0107333	33kΩ	1A
R606	0107561	560Ω	1A
R607	0107222	2.2kΩ	1A
R608	0107104	100kΩ	1B
R609	0107154	150kΩ	1B
R610	0107273	27kΩ	1B
R611	0107224	220kΩ	1B
R612	0107271	270Ω	1B
R613	0107181	180Ω	1A
R614	0107561	560Ω	1B, C
R615	0107479	4.7kΩ	1, 2B
R616	0107221	220Ω	1A, B
VR01(a~d)	1060320, 1	250kΩ × 2—250kMN MASTER, BALANCE Volume	1, 2B
VR02(a~b)	1010930, 1	100kΩ (B) TREBLE Volume	2C
VR03(a~b)	1010930, 1	100kΩ (B) MIDRANGE Volume	2C, D
VR04(a~b)	1010930, 1	100kΩ (B) BASS Volume	2D
S2(a, b)	1130770	TAPE MONITOR 1 Switch	2A
S3(a, b)	1130770	TAPE MONITOR 2 Switch	2A
S4	1130770	MODE Switch	2A, B
S5	1130770	FM MUTING Switch	2A
S6(a, b)	1130770	LOUDNESS Switch	2B

**5-6. F-2435 Filter Circuit Board**

(Stock No. 7592190 Complete Circuit Board F-2435)

**Conductor Side**

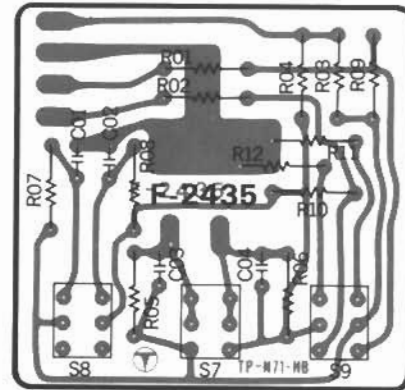

**Parts List**

Parts No.	Stock No.	Description
C01, 02	0600187	0.018μF } 50V M.C.
C03, 04	0600187	0.018μF }
R01, 02	0107332	3.3kΩ
R03, 04	0107223	22kΩ
R05, 06	0107824	820kΩ
R07, 08	0107824	820kΩ
R09, 10	0107333	33kΩ
R11, 12	0107332	3.3kΩ
R614	0107102	1kΩ
R615	0107479	4.7kΩ
S7	1130790	LOW FILTER Switch
S8	1130790	HIGH FILTER Switch
S9	1130790	AUDIO MUTING Switch

5-7. F-2436 Driver Circuit Board (Stock No. 7570940 Complete Circuit Board F-2436)  
Conductor Side

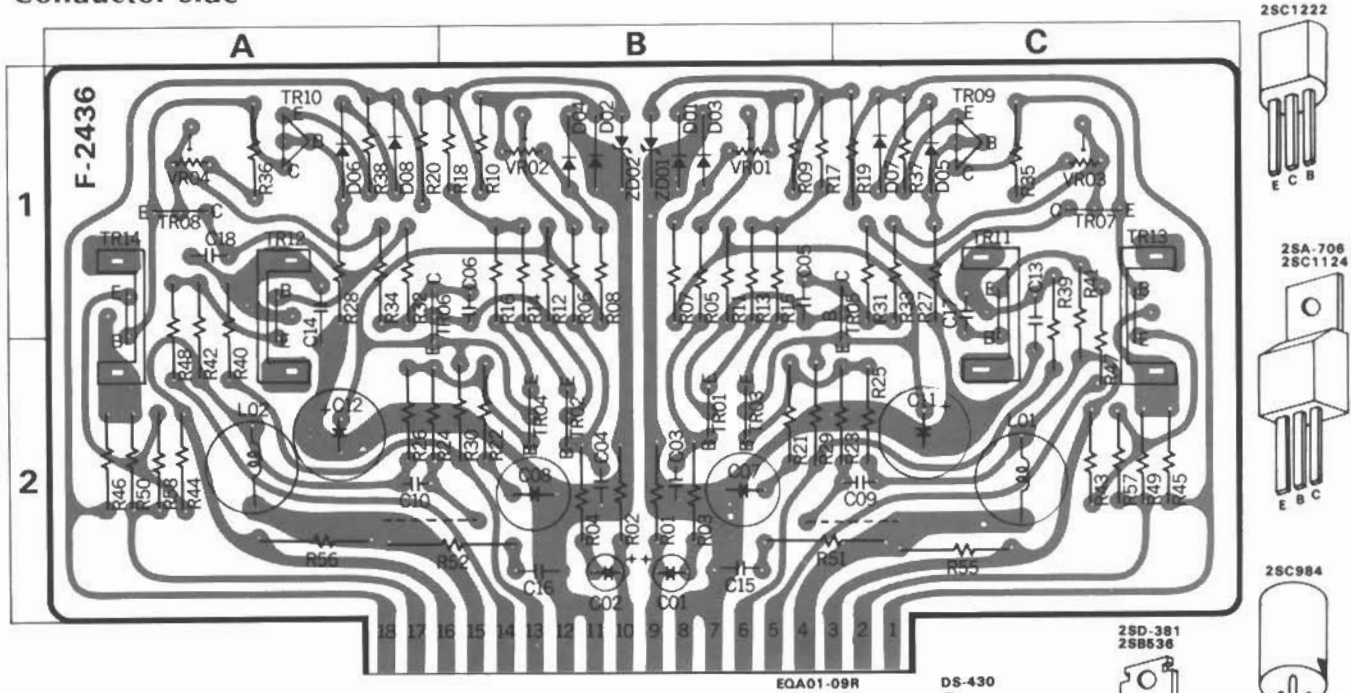

Parts List

Parts No.	Stock No.	Description	Position
TR01, 02	0306011, 2	2SC1222 (E, F)	2 B
TR03, 04	0306011, 2	2SC1222 (E, F)	2 B
TR05, 06	0300401, 2	2SA706 (2, 3)	1,2C.1,2A
TR07, 08	0305871, 2	2SC984 (B, C)	1 C. 1 A
TR09, 10	0305901, 2	2SC1124 (2, 3)	1 C. 1 A
TR11, 12	0308431, 2	2SD381 (L, M)	1,2C.1,2A
TR13, 14	0303261, 2	2SB536 (L, M)	1,2C.1,2A
D01, 02	0340090	DS-430	1 B
D03, 04	0340090	DS-430	1 B
D05, 06	0340090	DS-430	1 C. 1 A
D07, 08	0340090	DS-430	1 C. 1 A
ZD01, 02	0315860	EQA01-09R Zener Diode	1 B
C01, 02	0519103	0.47 $\mu$ F 50V E.C.	2 B
C03, 04	0660680	68pF 50V C.C.	2 B
C05, 06	0660220	22pF 50V C.C.	1 B
C07, 08	0530101	100 $\mu$ F 6.3V BP. E.C.	2 B
C11, 12	0515101	100 $\mu$ F 50V E.C.	2 C. 2 A
C13, 14	0657473	47000pF 50V C.C.	1,2C.1,2A
C15, 16	0600337	0.33 $\mu$ F 50V M.C.	2 B
C17, 18	0660680	68pF 50V C.C.	1 C. 1 A
R01, 02	0107124	120k $\Omega$	2 B
R03, 04	0107103	10k $\Omega$	2 B
R05, 06	0107124	120k $\Omega$	1 B
R07, 08	0107683	68k $\Omega$	1 B
R09, 10	0107223	22k $\Omega$	1 B
R11, 12	0107102	1k $\Omega$	1 B
R13, 14	0107479	4.7 $\Omega$	1 B
R15, 16	0107479	4.7 $\Omega$	1 B
R17, 18	0107332	3.3k $\Omega$	1 B
R19, 20	0103822	8.2k $\Omega$	1 C. 1 A

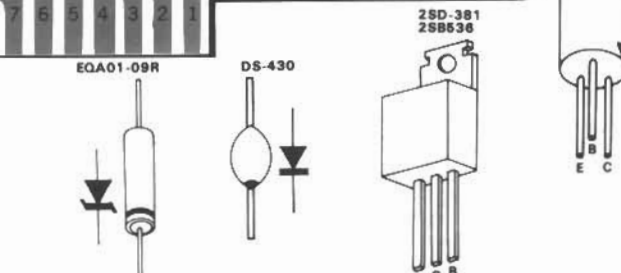

Parts No.	Stock No.	Description	Position
R21, 22	0107332	3.3k $\Omega$	2 B
R25, 26	0107124	120k $\Omega$	2 C. 2 A
R27, 28	0107333	33k $\Omega$	1 C. 1 A
R29, 30	0107101	100 $\Omega$	2 B
R31, 32	0107390	39 $\Omega$	1 C. 1 A
R33, 34	0107332	3.3k $\Omega$	1 C. 1 A
R35, 36	0107152	1.5k $\Omega$	1 C. 1 A
R37, 38	0107181	180 $\Omega$	1 C. 1 A
R39, 40	0107100	10 $\Omega$	1,2C.1,2A
R41, 42	0107151	150 $\Omega$	1,2C.1,2A
R43, 44	0107100	10 $\Omega$	2 C. 2 A
R45, 46	0107151	150 $\Omega$	2 C. 2 A
R47, 48	0107479	4.7 $\Omega$	1,2C.1,2A
R49, 50	0107479	4.7 $\Omega$	2 C. 2 A
R51, 52	0152100	10 $\Omega$ 2 W Ce. R.	2B,C.2A,B
R55, 56	0103479	4.7 $\Omega$ 1/2 W C.R.	2 C. 2 A,B
VR01, 02	1035350	4.7k $\Omega$ DC 0V Volume	1 B
VR03, 04	1035310	1k $\Omega$ Bias Current Volume	1 C. 1 A
L01, 02	4290210	2.5mH Output Coil	2 C. 2 A

Abbreviations

- C.R. : Carbon Resistor
- S.R. : Solid Resistor
- Ce.R. : Cement Resistor
- M.R. : Metallized Film Resistor
- M.C. : Mylar Capacitor
- E.C. : Electrolytic Capacitor
- BP.E.C.: Bi-Polar Electrolytic Capacitor
- C.C. : Ceramic capacitor
- Mi.C. : Mica Capacitor
- O.C. : Oil Capacitor
- P.C. : Polystyrene Capacitor
- T.C. : Tantalum Capacitor

# 5-8. F-2437 Power Supply Circuit Board (Stock No. 7500910 Complete Circuit Board F-1493) Conductor Side

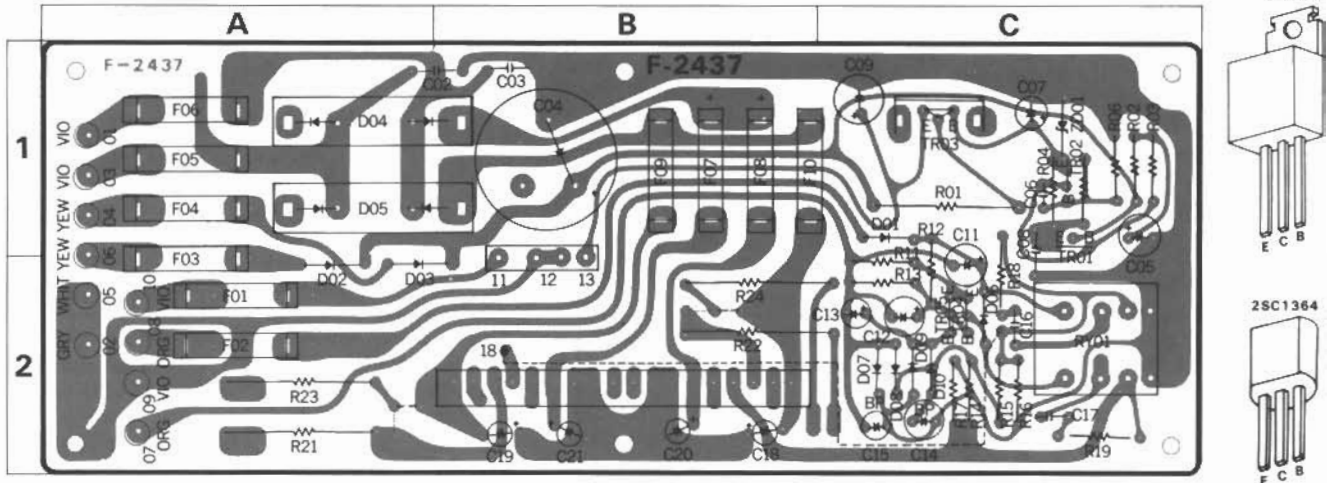

## Parts List

Parts No.	Stock No.	Description	Position
TR01	0308392, 3	2SD313 (E, F)	1C
TR02	0306131, 2	2SC1364 (6, 7)	1C
TR03	0308392, 3	2SD313 (E, F)	1C
TR04	0306131, 2	2SC1364 (6, 7)	2C
TR05	0306131, 2	2SC1364 (6, 7)	2C
D01	0310340	10D-1	1C
D02	0310340	10D-1	2A
D03	0310340	10D-1	2A, B
D04	0311310	SS-5	1A, B
D05	0311320	SS-5R	1A, B
D06	0310340	10D-1	2C
D07	0310400	IN34A	2C
D08	0310400	IN34A	2C
D09	0310400	IN34A	2C
D10	0310400	IN34A	2C
ZD01	{0315970 0316320}	{EQA01-13R RD13E-C} Zener Diode	1C
C02	0659011	10000pF 500V C.C.	1A, B
C03	0659011	10000pF	1B
C04	0549103	1000µF 50V E.C.	1B
C05	0515101	100µF	1C
C06	0660151	150pF 50V C.C.	1C
C07	0512470	47µF 16V E.C.	1C
C08	0657473	0.047µF 50V C.C.	1, 2C
C09	0512221	220µF 16V E.C.	1C
C11	0515470	47µF 50V E.C.	1, 2C
C12	0510221	220µF 6.3V E.C.	2C
C13	0515109	1µF 50V E.C.	2C
C14	0530470	4.7µF 6.3V BP. E.C.	2C
C15	0535109	1µF 50V	2C
C16	0600108	0.1µF 50V M.C.	2C
C17	0600108	0.1µF	2C
C18	0515339	3.3µF	2B
C19	0515339	3.3µF	2B
C20	0515339	3.3µF 50V E.C.	2B
C21	0515339	3.3µF	2B
R01	0135151	150Ω 5W Ce.R.	1C
R02	0107182	1.8kΩ	1C
R03	0107182	1.8kΩ	1C
R04	0107472	4.7kΩ	1C
R05	0107333	33kΩ	1C
R06	0107223	22kΩ	1C
R11	0107100	10Ω	2C

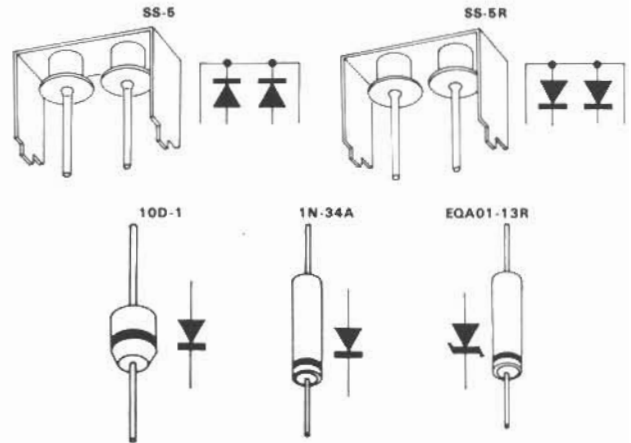

Parts No.	Stock No.	Description	Position
R12	0107104	100kΩ	1, 2C
R13	0107223	22kΩ	2C
R14	0107473	47kΩ	2C
R15	0107473	47kΩ	2C
R16	0107332	3.3kΩ	2C
R17	0107332	3.3kΩ	2C
R18	0171100	10Ω	1, 2C
R19	0171100	10Ω	2C
R21	0133338	0.33Ω	2A
R22	0133338	0.33Ω	2B, C
R23	0133338	0.33Ω	2A
R24	0133338	0.33Ω	2B, C
F01	0430900	5A	2A
F02	0430830	1A	2A
F03	0430850	2A	1, 2A
F04	0430850	2A	1A
F07	0433640	5A	1B
F08	0433640	5A	1B
F09	0433640	5A	1B
F10	0433640	5A	1B, C
RY01	1150251	Relay	2C
	2310150	Fuse holder for minutia fuse	
	5936691	Heat Sink	

## 5-9. Other Parts (Front Side)

### Parts List

Parts No.	Stock No.	Description	Parts No.	Stock No.	Description
1	5101165	Binding Head Screw, M4×20	62	0400390	6V, 30mA Lead Type Lamp (Stereo Indicator)
2	5186110	Plain Washer 4φ	63	0400320	7V, 100mA Lead Type Lamp (Phono Indicator)
3	5101165	Binding Head Screw, M4×20	64	0400330	7V, 100mA Lead Type Lamp (FM Indicator)
4	5186110	Plain Washer 8φ	65	0400310	7V, 100mA Lead Type Lamp (AM Indicator)
5	5726841	Wood Bonnet	66	0400320	7V, 100mA Lead Type Lamp (AUX-1 Indicator)
6	5317720	L-1 Type Knob (Speaker)	67	0400330	7V, 100mA Lead Type Lamp (AUX-2 Indicator)
7		Hex. Nut, M9	68	0420040	7V, 320mA Fuse Type Lamp (Dial Scale)
8		Plain Washer, 9φ	69	5058150	Illumination Box
9	5326490	Push Button	70	5109122	Binding Head Tapping Screw, M3×8
10	5317740	S-3 Type Knob (Bass Volume)	71	5109122	Binding Head Tapping Screw, M3×8
11	5317740	S-3 Type Knob (Midrange Volume)	72	5269961	Holder (Driver Circuit Board)
12	5317740	S-3 Type Knob (Treble Volume)	73	5101161	Binding Head Screw, M4×6
13		Hex. Nut, M9	74	5101161	Binding Head Screw, M4×6
14		Plain Washer, 9φ	75	5101161	Binding Head Screw, M4×6
15	5317820	T-6 Type Knob (Tuning)	76	5101165	Binding Head Screw, M4×14
16	5317830	WI-3 Type Knob (Volume)	77	5516911	Foot
17	5317840	WO-2 Type Knob (Balance Volume)	78	5101165	Binding Head Screw, M4×14
18	5317730	M-3 Type Knob (Selector)	79	5516911	Foot
19		Hex. Nut, M6	80	5058130	Bottom Plate
20		Plain Washer, 9φ			
21	5326490	Push Button			
22	5317870	R-5 Type Knob (MIC Level Volume)			
23	5102843	Flat Countersunk Head Screw, M3×6			
24	5102843	Flat Countersunk Head Screw, M3×6			
25	5309080	Front Panel			
26	5101043	Binding Head Screw, M3×6			
27	5101043	Binding Head Screw, M3×6			
28	5101043	Binding Head Screw, M3×6			
29	5047701	Smoked Plate			
30	5308910	Frame (Smoked Plate)			
31	7106083	Push Button (Power Switch)			
32	6906031	Spring (Power Switch)			
33	1130350	Power Switch			
34	2430200	Headphone Jack			
35	1102570, 1	Rotary Switch (Speaker)			
36	1130790	Push Switch			
37	1010930, 1	100kΩ (B) Bass Volume			
38	1010930, 1	100kΩ (B) Midrange Volume			
39	1010930, 1	100kΩ (B) Treble Volume			
40	1060320, 1	Balance & Master Volume			
41	1130770	Push Switch			
42	1005170, 1	20kΩ Mic Level Volume			
43	2430170	Mic Jack			
44	5109122	Binding Head Tapping Screw, M3×8			
45	1101600	} Rotary Switch (Selector)			
46	1101640, 1				
47	7036381	Tuning Ass'y			
48	5416360	Dial Pointer			
49	5407650	Dial Scale			
50	5109122	Binding Head Tapping Screw, M3×8			
51	5109122	Binding Head Tapping Screw, M3×8			
52	5109122	Binding Head Tapping Screw, M3×8			
53	5109122	Binding Head Tapping Screw, M3×8			
54	5269330	Holder (Signal Meter)			
55	5269330	Holder (Signal Meter)			
56	0420040	7V, 320mA Fuse Type Lamp			
57	0420040	7V, 320mA Fuse Type Lamp			
58	7726050	Meter Lamp Ass'y			
59	7726050	Metet Lamp Ass'y			
60	4300610, 1	Signal Meter			
61	4300600, 1	Center Meter			

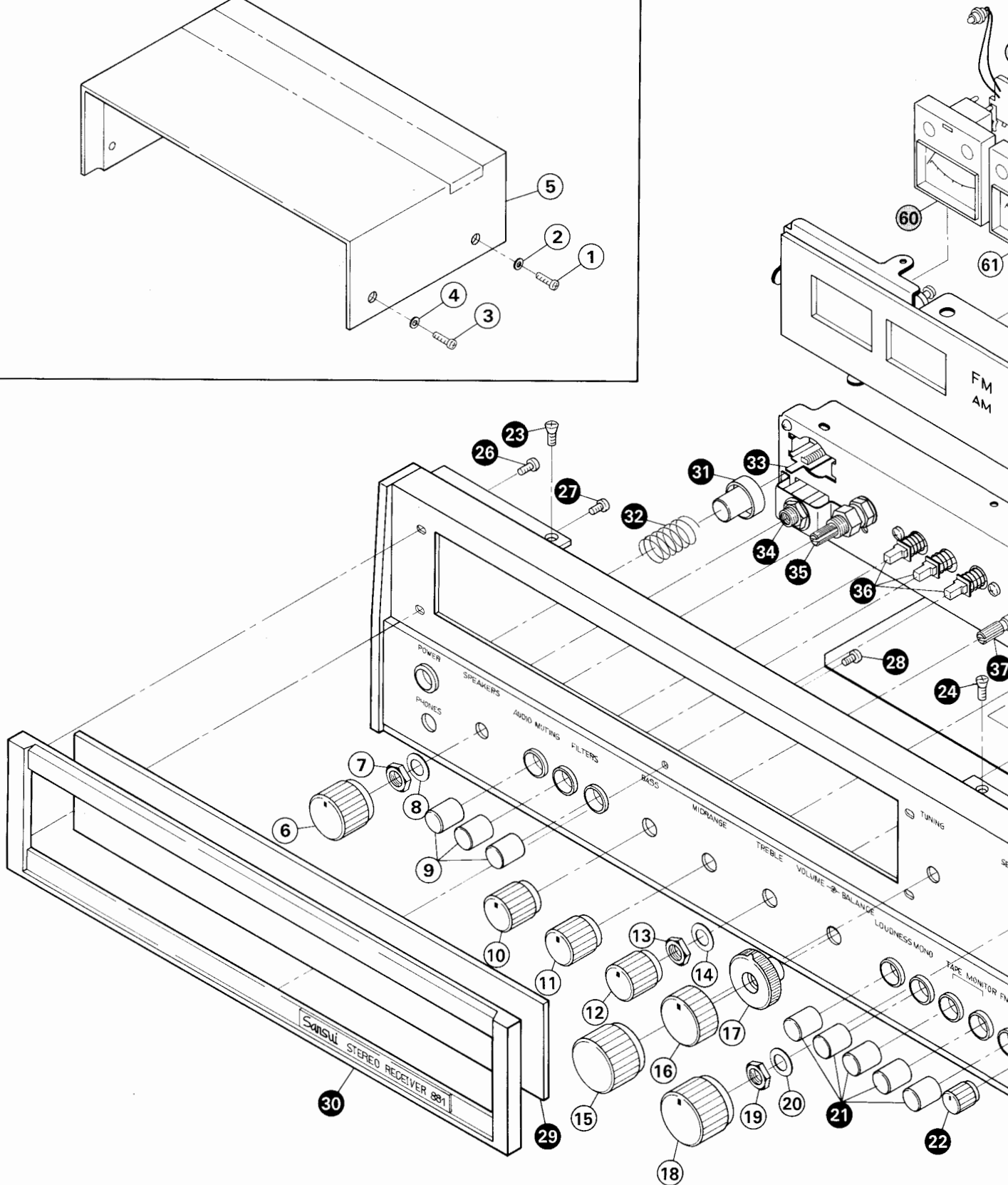
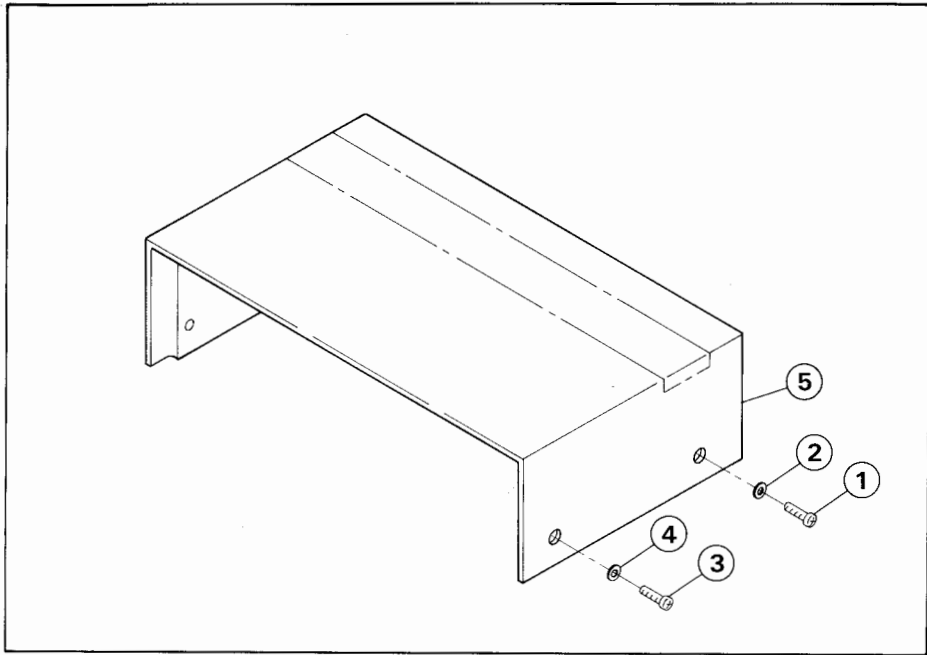

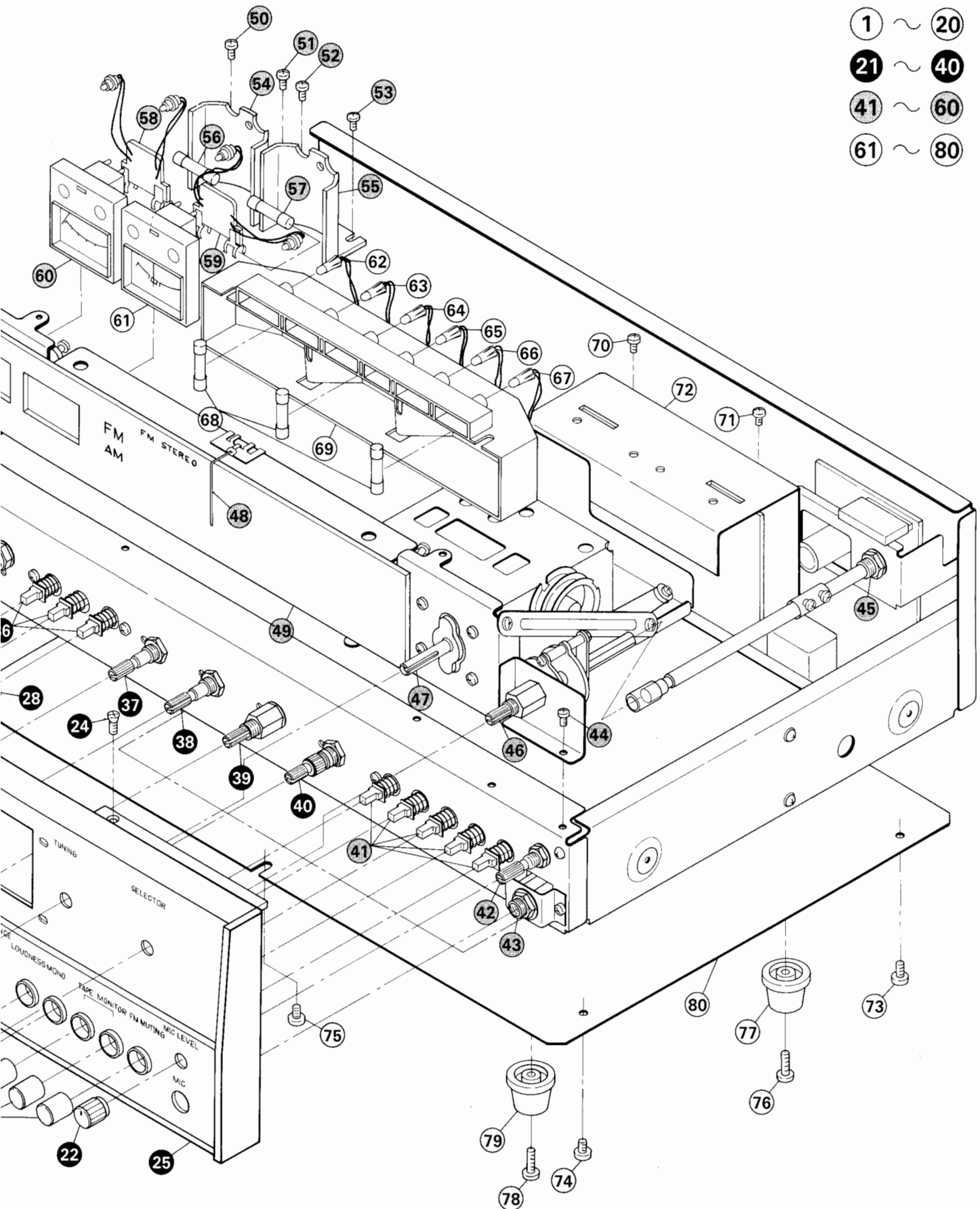

- ① ~ ②①
- ②① ~ ④①
- ④① ~ ⑥①
- ⑥① ~ ⑧①



### 5-10. Other Parts (Top Side)

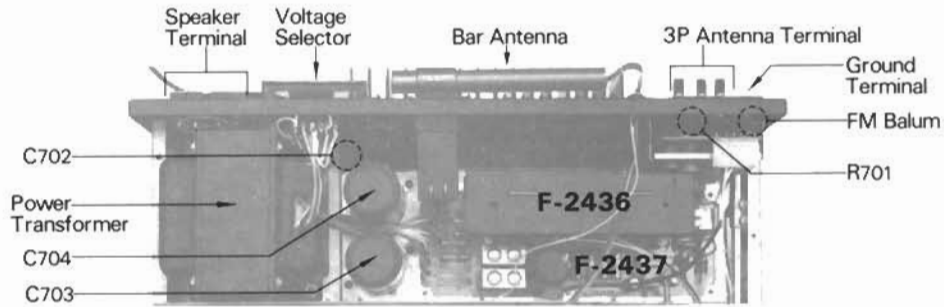

#### Parts List

Parts No.	Stock No.	Description
C702	0659802	0.0047 $\mu$ F 1.4kV C.C.
C703	0559360	10000 $\mu$ F } 50V E.C.
C704	0559360	10000 $\mu$ F }
R701	0113122	1.2k $\Omega$ 1/4 W S.R.
	2290100	4P Speaker Terminal
	2410080	Voltage Selector Socket

Parts No.	Stock No.	Description
	2410090	Voltage Selector Plug
	5268600	Voltage Selector Cover
PT01	4002070	Power Transformer
	4200710	Bar Antenna
	2210190	3P Antenna Terminal
	2230050	Ground Terminal
	4290021	75 $\Omega$ : 300 $\Omega$ FM Balun

### 5-11. Other Parts (Bottom Side)

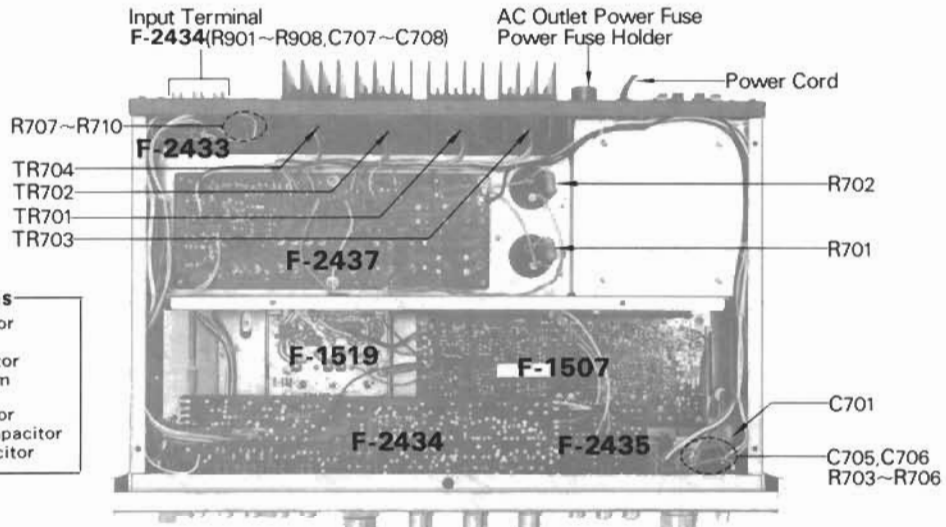

Abbreviations	
C.R.	: Carbon Resistor
S.R.	: Solid Resistor
Ce.R.	: Cement Resistor
M.R.	: Metallized Film Resistor
M.C.	: Mylar Capacitor
E.C.	: Electrolytic Capacitor
C.C.	: Ceramic capacitor

#### Parts List

Parts No.	Stock No.	Description
C701	0659801	0.01 $\mu$ F 1.4kV C.C.
C705	0600108	0.1 $\mu$ F } 50V M.C.
C706	0600108	0.1 $\mu$ F }
C709	0515109	1 $\mu$ F 50V E.C.
R701	0105332	3.3k $\Omega$ } 2W C.R.
R702	0105332	3.3k $\Omega$ }
R703	0152100	10 $\Omega$ } 2W Ce. R.
R704	0152100	10 $\Omega$ }
R705	0171331	330 $\Omega$ } 1W M.R.
R706	0171331	330 $\Omega$ }
R707	0107184	180k $\Omega$ } 1/4 W C.R.
R708	0107184	180k $\Omega$ }
R709	0107104	100k $\Omega$ }
R710	0107104	100k $\Omega$ }

Parts No.	Stock No.	Description
		F-2432 Input Terminal Circuit Board Ass'y
C707~C708	0657473	0.047 $\mu$ F 50V C.C.
R901~R908	0107224	220k $\Omega$ 1/4 W C.R.
	0431280	Power Fuse 5A
	2300060	Power Fuse Holder
	2450060	AC Outlet
	3800020	Power Cord
TR701	0306230 (1), (2)	2SC1115 (R, O, Y) } Power Transistor
TR702	0306230 (1), (2)	2SC1115 (R, O, Y) }
TR703	0306230 (1), (2)	2SC1115 (R, O, Y) }
TR704	0306230 (1), (2)	2SC1115 (R, O, Y) }

## 6. THREADING OF DIAL CORD

If dial cord is cut or slips, replace cord by following procedures. As 881 is used 0.6mm $\phi$  cord, please replace it with same type certainly.

\* Length of dial cord . . . . . approx. 150cm (59 inch)

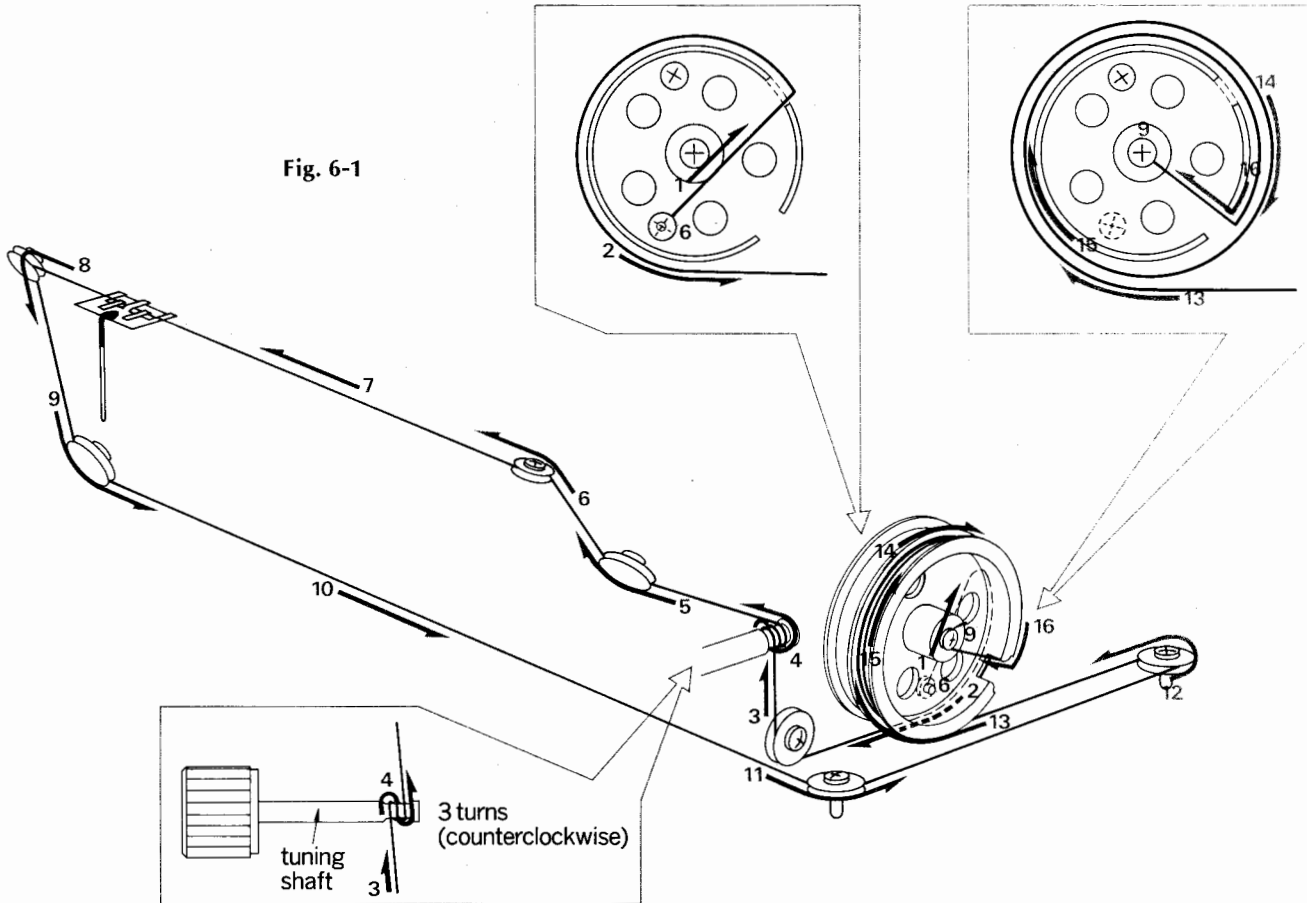

Fig. 6-1

### 6-1. Threading of Dial Cord

Thread dial cord in numerical order from 1 to 16 as shown in Fig. 6-1.

- 1) Close the variable capacitor completely (Max. capacitance) and tie cord to number ⑥ screw of the dial pulley.
- 2) Thread cord in the direction of arrow from 1 to 3, then wind cord three turns around the tuning shaft counterclockwise.
- 3) Thread cord in the direction of arrow from 4 to 12, then wind it two turns on the dial pulley from 13 to 16.
- 4) After 16, tie cord to number ⑨ screw of the dial pulley.

\* When you perform procedure 4) successfully, please refer to the followings.

- ① To strengthen the dial cord tension, hold around the end of cord and pull it toward the Front Panel.
- ② Then, turn tuning shaft counterclockwise, as the cord tension will be more constantly obtained.
- ③ Tie the cord to number ⑨ screw of the dial pulley (same as procedure 4).

- 5) After procedures, lock the knots of cord with paint.

### 6-2. Attachment of Dial Pointer

- 1) Close the variable capacitor completely.
- 2) Set the dial pointer to "0" on dial scale and install the dial pointer ass'y (See Fig. 6-2).

Fig. 6-2

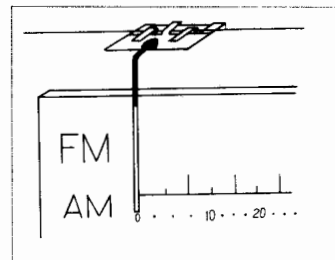

Stock No.	Description
6036050	Dial Cord (0.6mm $\phi$ )





## 8. PACKING LIST

Parts No.	Stock No.	Description
1	9116012	Vinyl Cover
2	9027770	Stylofoam Packing
3	9008081	Carton Case

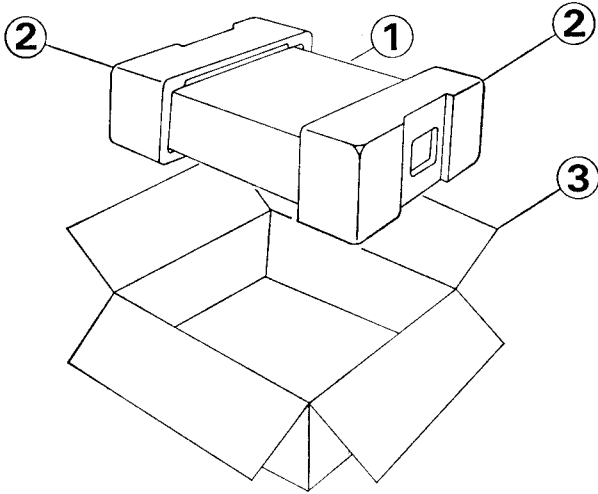

## 9. ACCESSORY PARTS LIST

Parts No.	Stock No.	Description
1	3820091	FM Antenna
2	0433640	5A Quick Acting Fuse
3	9208150	Operating Instructions
4	9228150	Operating Instruction Sheet



SANSUI ELECTRIC CO., LTD.

14-1, 2-chome, Izumi, Suginami-ku, Tokyo 168, Japan.  
TELEPHONE: (03) 323-1111 / TELEX: 232-2076

SM024

Printed in Japan (94830M)