

SERVICE MANUAL

AM/FM STEREO RECEIVER

SANSUI 990/890

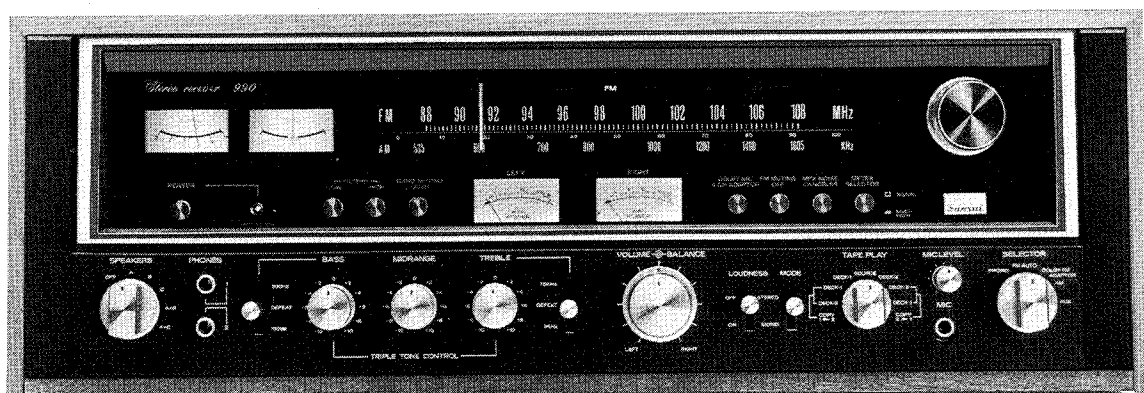

SANSUI ELECTRIC CO., LTD.

NOTE:

This service manual includes two model numbers, # 990 and # 890 together as indicated Model **A** and **B** in parts lists, schematic diagram and others.

MODEL **A** # 990

MODEL **B** # 890

When ordering parts, use the parts name and stock No. after confirming either Model **A** or **B**.

TABLE OF CONTENTS

<u>Section</u>	<u>Title</u>	<u>Page</u>
1.	SPECIFICATIONS	2
2.	THREADING OF DIAL CORD	3
	2-1. Threading of Dial Cord	3
	2-2. Attachment of Dial Pointer	3
3.	ALIGNMENTS AND ADJUSTMENT	3
	3-1. Driver Circuit Board Adjustment	4
	3-2. FM Adjustment & Alignment	4, 5, 6
	3-3. AM IF Adjustmet & Tracking	6
4.	OPERATION BLOCK DIAGRAM	7
	4-1. Tuner Section	7
	4-2. Audio Section	7
5.	TROUBLE SHOOTING CHART	8
	5-1. Audio Section	8
	5-2. Tuner Section	9
6.	PARTS LOCATION AND PARTS LIST	10
	6-1. F-2546 Power Supply Circuit Board	10
	6-2. F-2547 Protector Circuit Board	11
	6-3. F-2543 Tone Control Circuit Board	11
	6-4. F-2436 Driver Circuit Board	12
	6-5. F-2545 Filter & Muting Circuit Board	12
	6-6. F-2541 Equalizer Circuit Board	13
	6-7. F-2431 Power Supply Circuit Board	13
	6-8. F-2544 Tone Control Circuit Board	14
	6-9. F-2542 Accessory Switch Circuit Board	14
	6-10. F-2549 FM, AM Tuner Circuit Board	15, 16
	6-11. F-2550 Multi-Path Circuit Board	16
	6-12. F-1470 Lamp Circuit Board	16
	6-13. F-2597 Connector Circuit Board	16
	6-14. F-2548 Protector Connector Circuit Board	16
	6-15. F-1519 FM Pack	17
	6-16. Figures	17
7.	SCHEMATIC DIAGRAM	18, 19, 20
8.	OTHER PARTS	21
	8-1. Other Parts (Top Side)	21
	8-2. Other Parts (Front Side)	21, 22
9.	PACKING LIST	22
10.	ACCESSORY PARTS LIST	22

1. SPECIFICATIONS

AUDIO SECTION

POWER OUTPUT

Min. RMS, both channels driven, from 20 to 20,000Hz, with no more 0.2% total harmonic distortion

- *MODEL Ⓐ { 110 watts per channel into 8 ohms
Min. RMS, both channels driven, at 1kHz, with no more than 0.2% total harmonic distortion 120 watts per channel into 8 ohms
- *MODEL Ⓑ { 80 watts per channel into 8 ohms
Min. RMS, both channels driven, at 1kHz, with no more than 0.2% total harmonic distortion 90 watts per channel into 8 ohms

LOAD IMPEDANCE 8 ohms

POWER BANDWIDTH 20 to 20,000Hz at or below rated min. RMS power output and total harmonic distortion

TOTAL HARMONIC DISTORTION less than 0.2% at or below rated min. RMS power output

INTERMODULATION DISTORTION (70Hz : 7kHz = 4 : 1 SMPTE method) less than 0.2%

FREQUENCY RESPONSE (at 1 watt) 10 to 30,000Hz ±1dB

RIAA CURVE DEVIATION (PHONO) +0.5dB, -0.5dB (30Hz to 15kHz)

DAMPING FACTOR approximately 10 at 8 ohm load
INPUT SENSITIVITY AND IMPEDANCE (1kHz. for rated power output)

PHONO 2.5mV/50 kilo ohms
(Max. input capability: 200mV at 1kHz, less than 0.2% total harmonic distortion.)

TAPE PLAY, AUX 100mV/50 kilo ohms

OUTPUT LEVEL (1,000Hz)
TAPE-1, 2 REC (pin jacks) 100mV

TAPE-2 REC/PLAY (DIN socket) 30mV

PRE OUT 750mV

CHANNEL SEPARATION (at rated output 1,000Hz)

PHONO better than 50dB

TAPE PLAY, AUX better than 50dB

HUM AND NOISE

PHONO better than 70dB

TAPE PLAY, AUX better than 80dB

CONTROLS

BASS ±10dB (50Hz)

*MODEL Ⓐ ONLY

TONE SELECTOR (turnover frequency) 150, 300Hz

MIDRANGE ±5dB (1.5kHz)

TREBLE ±10dB (10kHz)

*MODEL Ⓐ ONLY

TONE SELECTOR (turnover frequency) 1.5, 3kHz

LOUDNESS +10dB (50Hz)
+8dB (10kHz)

LOW FILTER -10dB (50Hz)

HIGH FILTER -10dB (10kHz)

AUDIO MUTING -20dB

FM SECTION

TUNING RANGE 88 to 108MHz

SENSITIVITY (IHF) 1.7µV

(DIN) 0.9µV

QUIETING SLOPE (Mono) .. 3µV (50dB)

TOTAL HARMONIC DISTORTION

STEREO less than 0.3%

NONO less than 0.2%

SIGNAL TO NOISE RATIO (mono)

SELECTIVITY better than 85dB

CAPTURE RATIO less than 1.5dB

IMAGE REJECTION better than 75dB (98MHz)

IF REJECTION better than 90dB (98MHz)

SPURIOUS REJECTION better than 90dB (98MHz)

SPURIOUS RADIATION less than 34dB

STEREO SEPARATION better than 40dB (1kHz)

FREQUENCY RESPONSE 30 to 15,000Hz ^{+0.5} _{-2.0} dB

ANTENNA INPUT IMPEDANCE

..... 75Ω unbalanced

300Ω balanced

AM SECTION

TUNING RANGE 535 to 1,605kHz

SENSITIVITY (Bar antenna) .. 50dB/m (1,000kHz)

SELECTIVITY better than 50dB (1,000kHz)

IMAGE REJECTION better than 80dB/m (1,000kHz)

IF REJECTION better than 80dB/m (1,000kHz)

OTHERS

POWER REQUIREMENTS

POWER VOLTAGE 100, 120, 220, 240V (50/60Hz)

POWER CONSUMPTION

*MODEL Ⓐ 270 watts (rated)

*MODEL Ⓑ 180 watts (rated)

DIMENSIONS 540mm (21-⁵/₁₆") W

182mm (7-³/₁₆") H

399mm (15-¹¹/₁₆") D

WEIGHT

*MODEL Ⓐ { 23.3 kg (51.4 lbs) net
25.7 kg (56.7 lbs) packed

*MODEL Ⓑ { 20.9 kg (46.1 lbs) net
23.3 kg (51.4 lbs) packed

NOTE: In this specifications, there are two model numbers as model Ⓐ and Ⓑ. Regarding name of model Ⓐ, Ⓑ, please refer to "Notes" indicated on page 1.

* Design and specifications subject to change without notice for improvements.

2. THREADING OF DIAL CORD

*If a dial cord is cut off or slips, replace it by following procedures.
 As these units use 0.6mmφ cord, please replace it with the same type certainly.
 *The length of dial cord is approximately 145cm (59 inch).

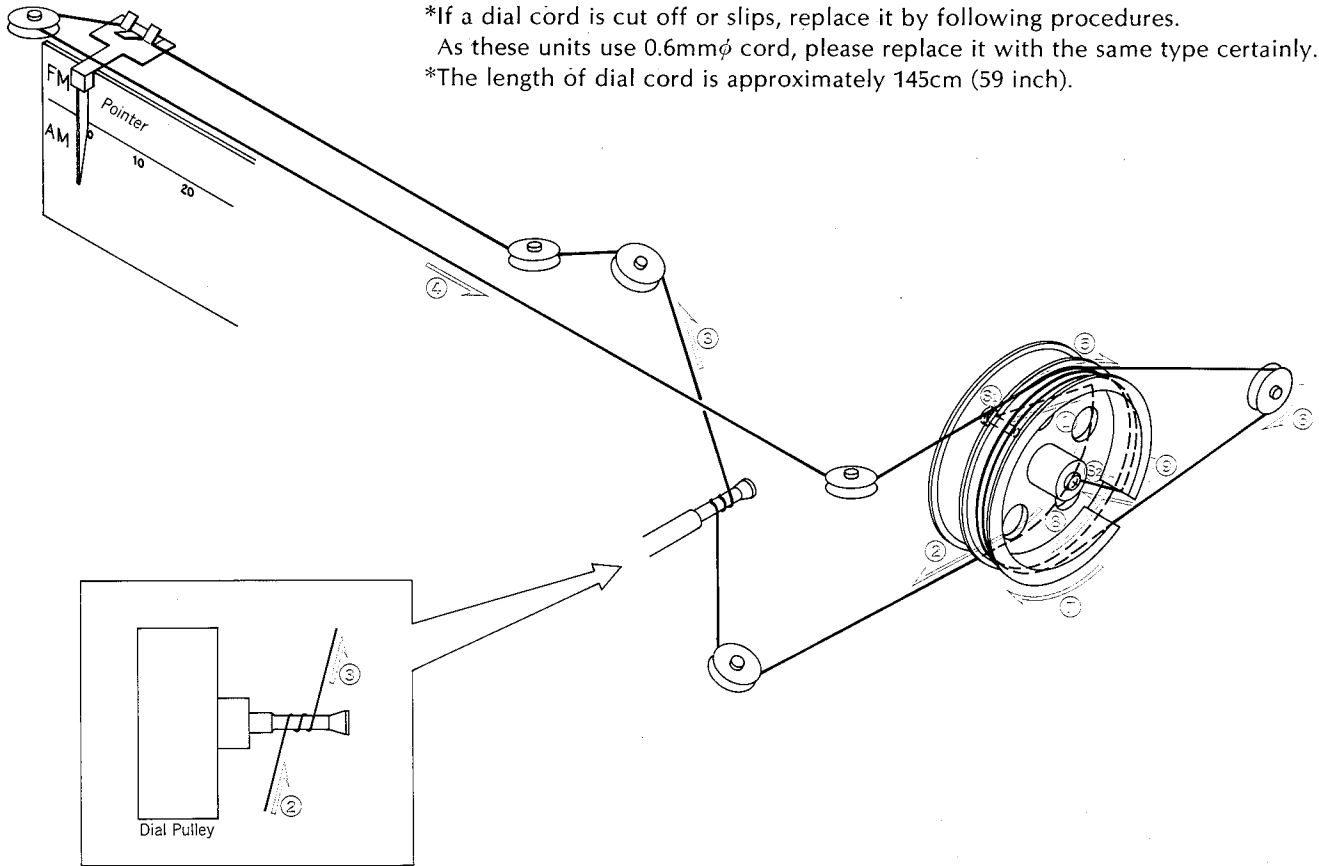

2-1. Threading of Dial Cord

Thread the dial cord in numerical order from ① to ⑨ as Fig. 2-1.

- 1) Close the variable capacitor completely (Max. capacitance).
- 2) Tie dial cord to the screw, S1.
- 3) Thread cord in the direction of arrow from ① to ⑨
- 4) After ⑨, tie the cord to the screw S2 of the dial pulley.

2-2. Attachment of Dial Pointer

- 1) Close the variable capacitor completely.
 - 2) Set the dial pointer to the 0 position on dial scale.
- *Confirm that the dial pointer runs smoothly on the dial scale by turning the tuning shaft.

Stock No.	Description
6036051	Dial Cord (0.6mmφ)
6146670	D44 Type Pulley

3. ALIGNMENTS AND ADJUSTMENT

Abbreviation

Equipment

AM FM Generator Oscilloscope Genescope
 AM Signal Generator AM SG
 FM Signal Generator FM SG
 Multiplex Stereo Generator Scope
 Oscilloscope Audio Osc.
 Audio Oscillator Dist. Meter

Others

Clockwise CW.
 Counterclockwise CCW.
 Antenna ANT.
 Modulation MOD.

3-1. Driver Circuit Board Adjustments (See Fig. 3-1, 3-2 on page 4)

- Note:** 1. Master Volume.....Minimum
 2. Before adjustment, run the unit for more than 4 minutes, then check and readjust necessary.

STEP	SUBJECT	EQUIPMENT	MEASURE OUTPUT	ADJUST	ADJUST FOR	CONDITION
1.	DC 0V L-CH	DC volt Meter	Speaker Terminal L-CH	VR01 F-2436	0V \pm 10mV	<ul style="list-style-type: none"> Step down meter range accordingly. Change leads polarity if meter swings backward.
2.	DC 0V R-CH	Same as above	Speaker Terminal R-CH	VR02 F-2436	Same as above	Same as above
3.	Bias Current L-CH	DC Milliammeter	F07 F-2546	VR03 F-2436	*MODEL A 50mV \pm 1 mA *MODEL B 30mA \pm 1 mA	Step down meter range accordingly
4.	Bias Current R-CH	Same as above	F08 F-2546	VR04 F-2436	Same as above	Same as above

Fig. 3-1

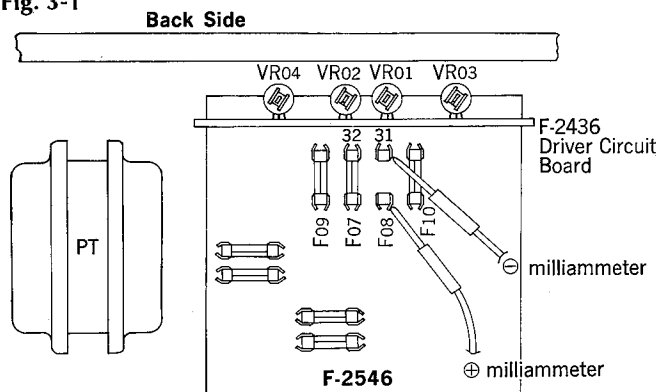

Note: In adjustment above, there are two model numbers as model A and B. Regarding name of model A, B, please refer to "Note" indicated on page 1.

Fig. 3-2

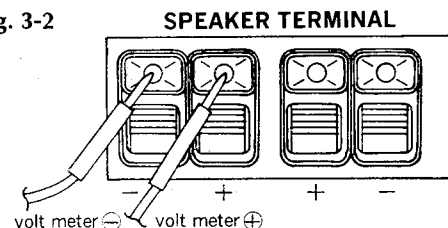

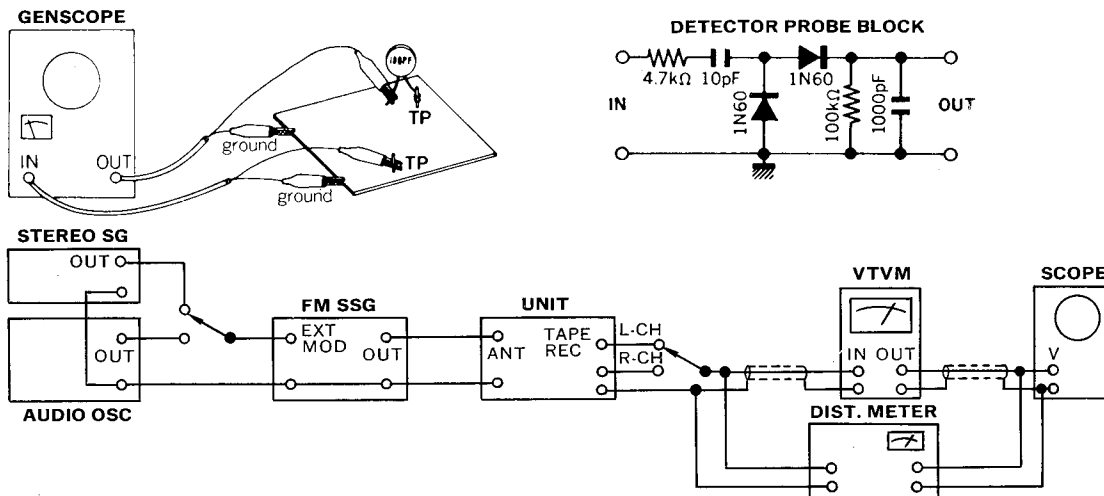

3-2. FM Adjustment & Alignment

- Note:** 1. Selector.....FM AUTO 2. FM MUTING SwitchOFF
 3. Connection.....Connect the output of genescope to TP through 100pF ceramic capacitor.
 {Output level of genescope.....After attenuator
 4. Sweep width1.5~2cm/150kHz
 {Frequency band9.5~11.5MHz

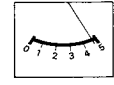
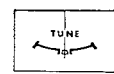

1) FM IF Adjustment & Tracking (See Fig. 3-3, 3-4, 3-5 on page 6)

STEP	SUBJECT	FEED SIGNAL		MEASURE OUTPUT	ADJUST	ADJUST FOR	CONDITION
		FROM	TO				
1.	IF coil	Output 90dB Genescope	TP01 FM, AM Pack F-1519	Terminal 01 of F-2549. Use Detector Probe	L05 F-1519	Max. IF waveform	
		Output 50dB Genescope	Same as above	TP01 F-2549	T01 F-2549	Same as above	
2.	Muting Coil	Output 50dB Genescope	Same as above	TP04 F-2549	T04 F-2549	Same as above	
3.	Discriminator Coil	Output 50dB Genescope	Same as above	TP03 F-2549	T02 T03 F-2549	Max. linearity of S Curve	
4.	90MHz Dial Calibration	90MHz ANT Input 60dB 400Hz (100% MOD) FM SSG	ANT Terminal 300Ω	REC OUT L or R-CH VTVM & Scope	L06 F-1519	Max. Output	
	106MHz Dial Calibration	106MHz ANT Input 60dB 400Hz (100% MOD) FM SSG	Same as above	Same as above	TC04 F-1519	Same as above	
5.	90MHz RF Adj.	90MHz ANT Input 60dB 400Hz (100% MOD) FM SSG	Same as above	Same as above	L01, L02, L03 F-1519	Same as above	
	106MHz RF Adj.	106MHz ANT Input 60dB 400Hz (100% MOD) FM SSG	Same as above	Same as above	TC01 TC02 TC03 F-1519	Same as above	
6.	Signal Meter Volume	98MHz ANT Input 100dB 400Hz (100% MOD) FM SSG	Same as above	Signal Meter	VR02 F-2549	4.7 on meter	
7.	Distortion	98MHz ANT Input 60dB 400Hz (100% MOD) FM SSG	Same as above	REC OUT L or R-CH Dist meter & Scope	T02 T03 } T01 } F-2549	Max. Output Min. Distortion	T01.. Slightly adjust
8.	Tune Meter Volume	98MHz ANT Input 60dB 400Hz (100% MOD) FM SSG	Same as above	Tune meter	VR01 F-2549	Center on meter	

2) MPX Alignment (See Fig. 3-4, 3-5 on page 6)

STEP	SUBJECT	FEED SIGNAL		MEASURE OUTPUT	ADJUST	ADJUST FOR	CONDITION
		FROM	TO				
1.	PLL VCO Adj.	98MHz ANT Input 60dB FM SSG Pilot 19kHz (10% MOD) L-CH 1kHz (45% MOD) R-CH (0% MOD) STEREO SG	ANT Terminal 300Ω	Stereo Indicator	VR04 F-2549	Light Indicator	Adjust the VR within center of lighting level.
	PLL VCO Adj. In case of using Freq Counter		Make short between TP02 of F-2549 and chassis	TP02 F-2549 Use Freq. Counter	VR04 F-2549	76kHz (±200Hz)	
2.	Separation	98MHz ANT Input 60dB FM SSG Pilot 19kHz (10% MOD) L-CH (0% MOD) R-CH 1kHz (45% MOD) STEREO SG	ANT Terminal 300Ω	REC OUT L-CH VTVM & Scope	VR05 F-2549	Min. Output -35dB	
3.	Distortion	Same as above	Same as above	REC OUT L-CH Dist. meter & Scope	L05 1 Side 2 Side AM, FM Pack F-1519	Min. Distortion	If less than 0.3%, adjust L05 slightly.
4.	Separation	98MHz ANT Input 60dB FM SSG Pilot 19kHz (10% MOD) L-CH 1kHz (45% MOD) R-CH (0% MOD) STEREO SG	Same as above	REC OUT R-CH VTVM & Scope	VR05 F-2549	Min. Output -30dB	
5.	Muting level & Indicator level	98MHz ANT Input 23dB FM SSG Pilot 19kHz(10%MOD) L-CH 1kHz(45% MOD) R-CH (0% MOD) STEREO SG	Same as above	Stereo Indicator	VR03 F-2549	Muting level 23dB Indicator lighting level 23dB	

3-3. AM IF Adjustments & Tracking (See Fig. 3-4, 3-5 on page 6)

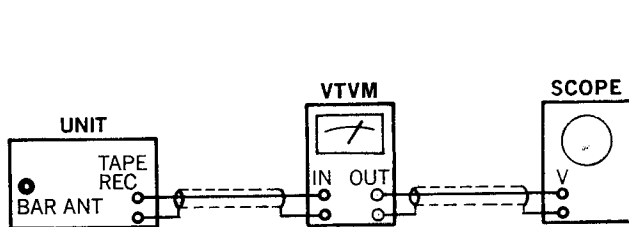

- Note:** 1. Selector..... AM
2. Confirm start point of dial pinter before alignment.

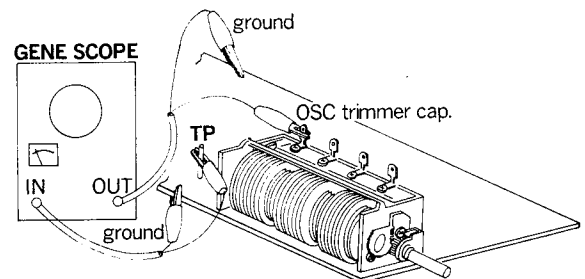



STEP	SUBJECT	FEED SIGNAL		MEASURE OUTPUT	ADJUST	ADJUST FOR	CONDITION
		FROM	TO				
1.	IF Coil	Genescope Output 70dB	TC05 FM, AM Pack F-1519	TP06 F-2549	CF04 F-2549	Max. Output	
2.	600kHz Dial Calibration	600kHz ANT Input 60dB 400Hz (MOD 30%) AM SSG	AM ANT Terminal	REC OCT L or R-CH VTVM & Scope	T05 F-2549	Same as above	
	1400kHz Dial Calibration	1400kHz ANT Input 60dB 400Hz (MOD 30%) AM SSG	Same as above	Same as above	TC05 FM, AM Pack F-1519	Same as above	
3.	600kHz RF Adj.	600kHz ANT Input 50dB 400Hz (MOD 30%) AM SSG	Same as above	Same as above	Bar Antenna T702	Same as above	
	1400kHz RF Adj.	1400kHz ANT Input 50dB 400Hz (MOD 30%) AM SSG	Same as above	Same as above	TC06 FM, AM Pack F-1519	Same as above	
4.	Signal Meter	1000kHz ANT Input 80dB	Same as above	Signal Meter	VR06 F-2549	4.3 on meter	

Fig. 3-3

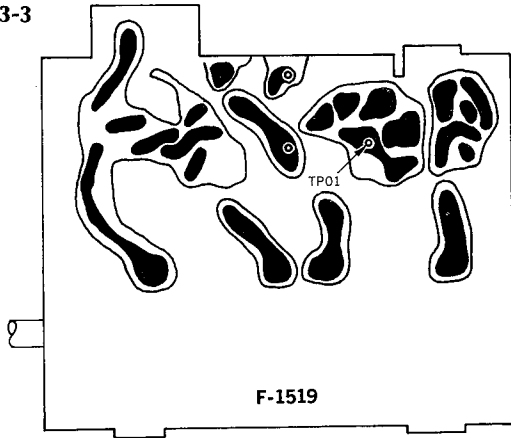

Fig. 3-4

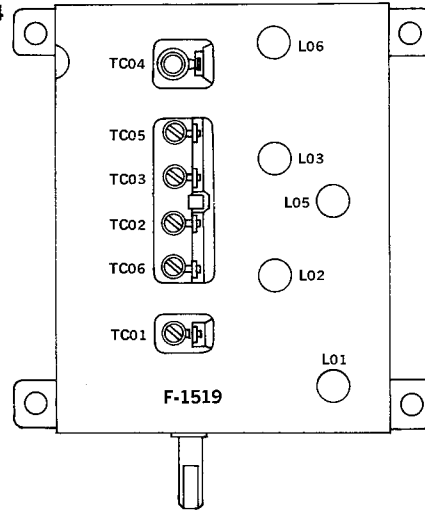
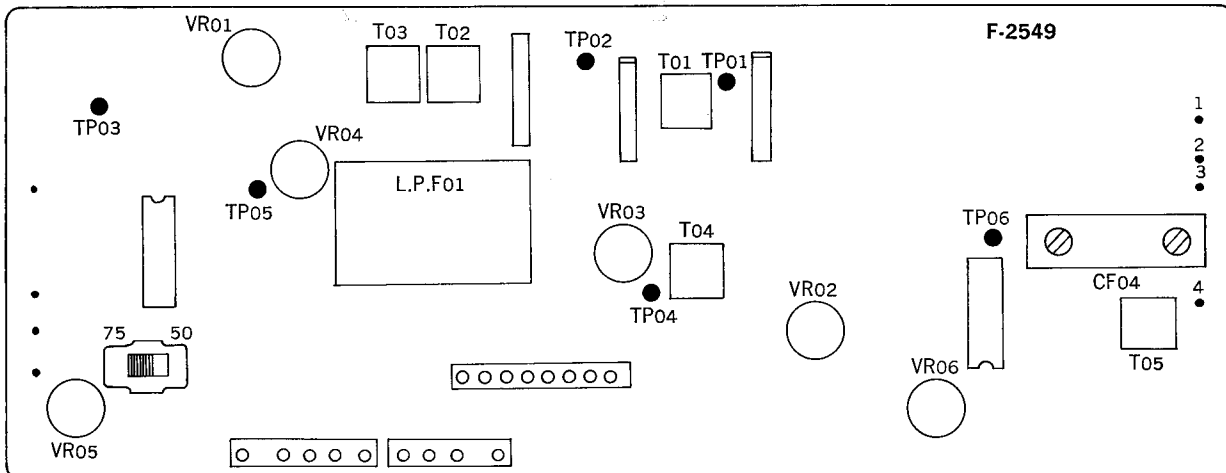
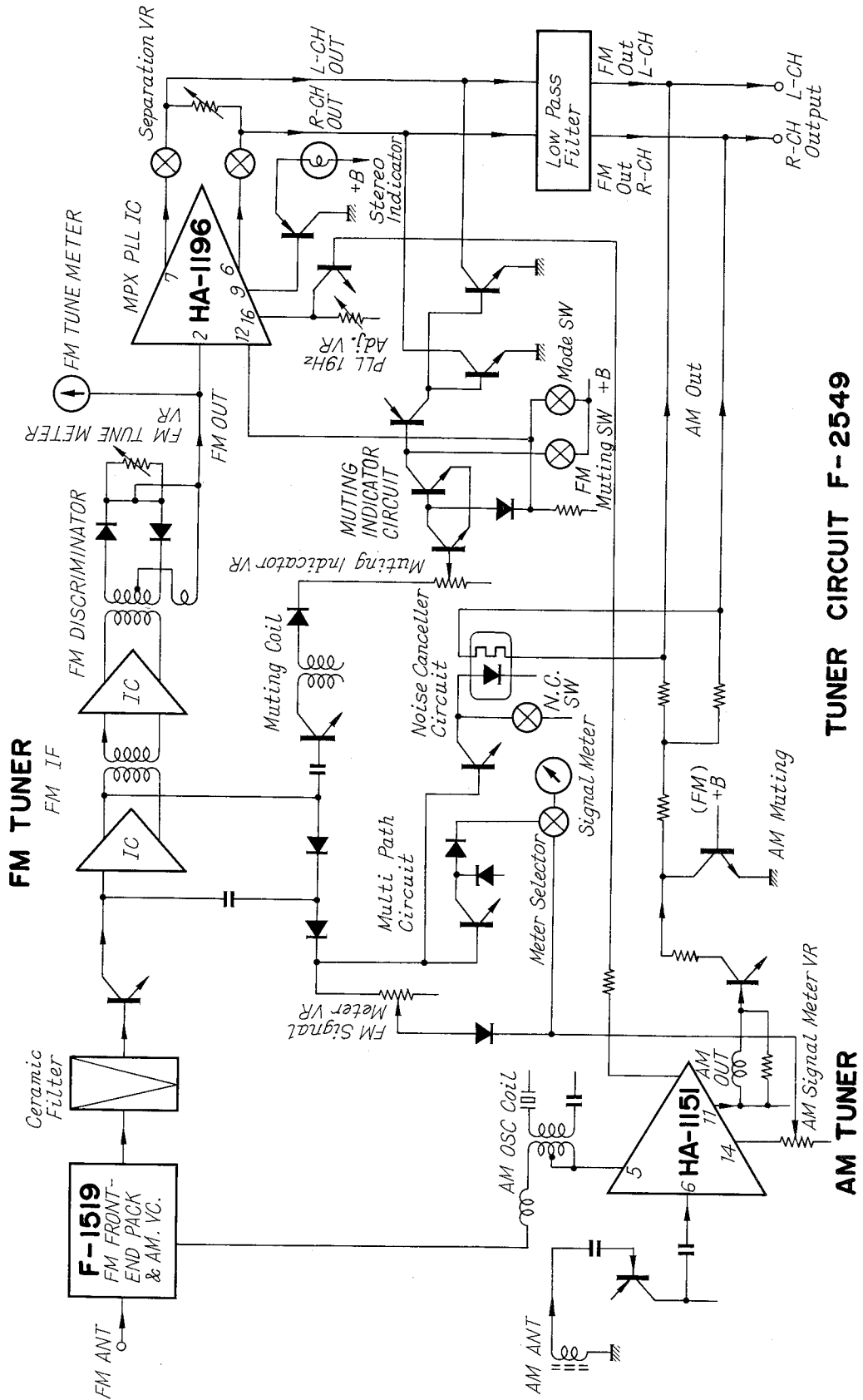

Fig. 3-5



4. OPERATION BLOCK DIAGRAM

4-1. Tuner Section



TUNER CIRCUIT F-2549

AM TUNER

4-2. Audio Section

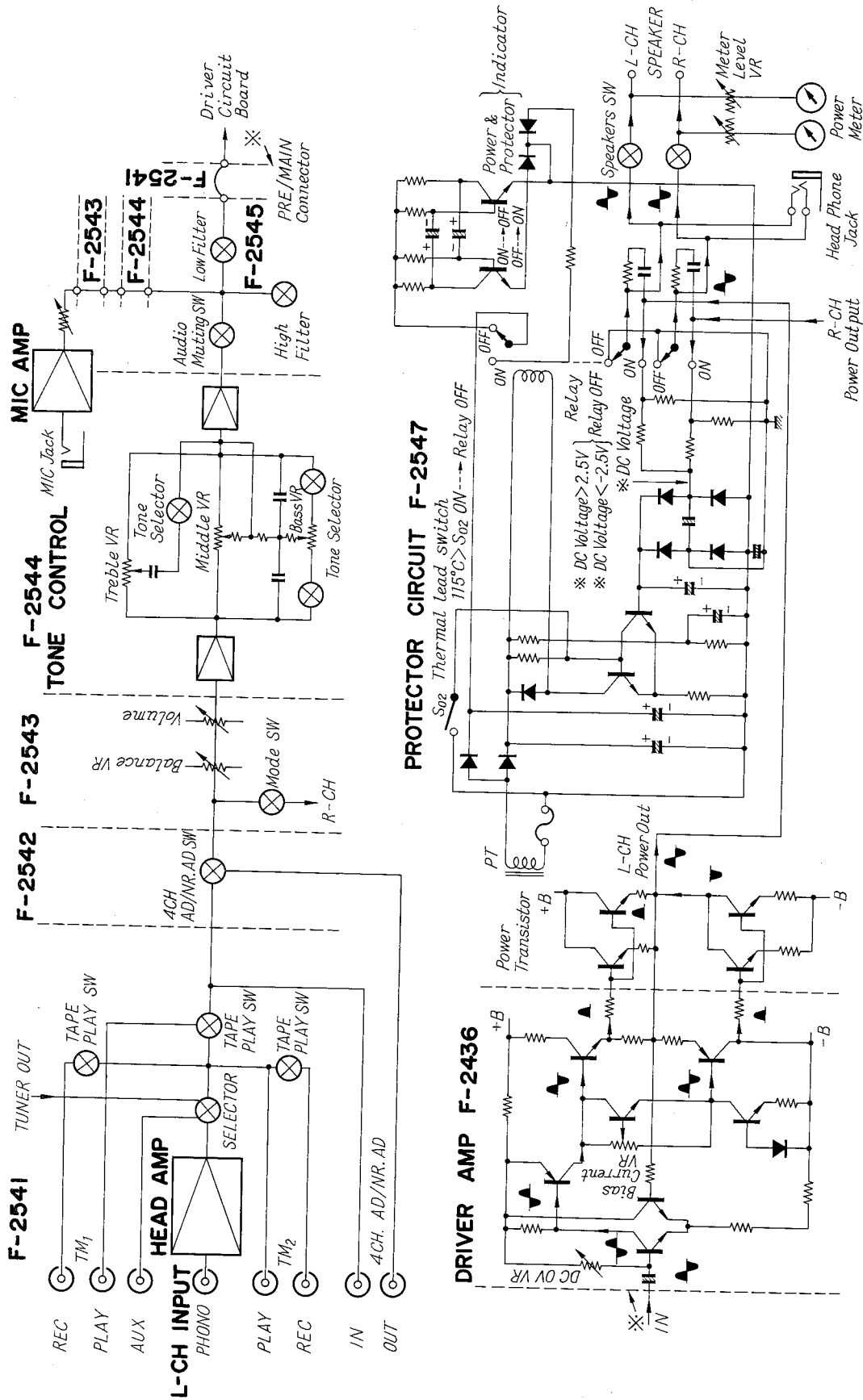

5. TROUBLESHOOTING CHART

5-1. Audio Section

Symptom	Defective Circuit or Check Point	Cause
1) Troubles on Power Supply section	<p>Defective parts in circuit on primary side of power transformer</p> <p>Defective rectifier circuit in secondary side of power transformer</p> <p>Defective or regulated power supply section</p>	<p>1. Power fuse, F701 opens</p> <p>2. Defective power switch, S701</p> <p>3. Imperfect contact of voltage selector</p> <p>1. AC fuse, F01~F06 opens</p> <p>2. Defective diode, D02, D03 on F-2546</p> <p>1. Defective D01 on F-2546</p> <p>2. Defective TR01~TR03 on F-2546</p>
2) Troubles on protector section	<p>Protector circuit inoperative when DC voltage is given to output of power stage</p> <p>Defective protection circuit with thermal lead switch</p> <p>Protector indicator does not flicker</p>	<p>1. Defective D04~D07 on F-2547</p> <p>2. Defective TR01, TR02 on F-2547</p> <p>3. Defective relay, RL01</p> <p>1. Defective thermal lead switch, S702</p> <p>2. Defective TR01, TR02 on F-2547</p> <p>3. Defective relay, RL01</p> <p>1. Defective TR03, TR04 on F-2547</p> <p>2. Defective C06, C07 on F-2547</p> <p>3. Defective LED01 on F-2548</p>
3) Troubles on Power AMP. section	<p>Quick acting fuse opens</p> <p>One channel inoperative</p> <p>Over-flow bias current</p>	<p>1. Power transistor shorted</p> <p>2. Defective TR11~TR14 on F-2436</p> <p>3. TR07 on F-2436 opens</p> <p>4. Defective protector circuit</p> <p>1. Defective TR01~TR03 on F-2436</p> <p>1. Incorrect adjustment VR03, VR04 on F-2436</p>
4) Troubles on Tone Control section	<p>Inoperative tone control circuit</p> <p>Noise is produced by turning tone volume controls</p>	<p>1. Defective IC01 on F-2544</p> <p>2. Defective TR01 on F-2544</p> <p>1. Defective tone control volume VR01, VR02 on F-2544</p>
5) Troubles on MIC AMP. section	Inoperative Mic AMP. circuit	<p>1. Defective IC601 on F-2543</p> <p>2. Defective TR601 on F-2543</p> <p>3. Imperfect contact of MIC Jack</p>
6) Troubles on Equalizer section	Inoperative equalizer circuit	<p>1. Defective IC01, IC02 on F-2541</p> <p>2. Imperfect contact of selector</p> <p>3. Imperfect contact of Tape switch</p>
7) Power meter inoperative	Meter circuit inoperative	<p>1. Imperfect adjustment of VR01, VR02 on F-2547</p> <p>2. Defective M701, M702</p> <p>3. Defective D10~D12 on F-2547</p>

5-2. Tuner Section

Symptom	Defective Circuit or Check Point	Cause
1) Both AM and FM inoperative	Power supply section inoperative	<ol style="list-style-type: none"> 1. Defective TR01 on F-2431 2. Imperfect contact of selector switch
2) AM inoperative	Defective semiconductors Defective coils	<ol style="list-style-type: none"> 1. Defective TR12 on F-2549 2. Defective IC05 on F-2549 3. Defective TR13, TR14 on F-2549 <ol style="list-style-type: none"> 1. Osc coil opens 2. Bar antenna coil opens
3) AM poor sensitivity	Incorrect adjustment	<ol style="list-style-type: none"> 1. IF or Tracking out of adjustment
4) Signal meter does not properly operate	Defective meter circuit	<ol style="list-style-type: none"> 1. Signal meter volume, VR06 out of adjustment 2. Defective signal meter, M703
5) FM inoperative	Defective FRONT-END PACK F-1519 Defective IF section	<ol style="list-style-type: none"> 1. Defective FET01, TR01, 02 on F-1519 2. Coil, L01~L06 on F-1519 opened <ol style="list-style-type: none"> 1. Defective TR01~TR03 on F-2549 2. Defective IC01~IC03 on F-2549 3. T01, T02 on F-2549, opened
6) FM poor sensitivity	Incorrect adjustment Poor FM input signal	<ol style="list-style-type: none"> 1. RF and Tracking out of adjustment 2. IF coil and discriminator coil out of adjustment <ol style="list-style-type: none"> 1. Weak electric field intensity area
7) Signal meter does not properly operate	Defective meter circuit	<ol style="list-style-type: none"> 1. Defective D05~D07 on F-2549 2. Signal meter volume VR02 out of adjustment
8) MPX inoperative	Defective PLL circuit Defective semiconductors	<ol style="list-style-type: none"> 1. Defective IC04 on F-2549 2. TR10, TR11 on F-2549 shorted
9) No channel separation on FM stereo reception	Incorrect adjustment	<ol style="list-style-type: none"> 1. Muting coil, T04 out of adjustment 2. Muting, Indicator volume, VR03 out of adjustment 3. Free-run frequency adjust. Volume, VR04 out of adjustment 4. Separation volume, VR05 out of adjustment 5. Defective TR08 on F-2549
10) Troubles on Muting indicator circuit	Muting inoperative	<ol style="list-style-type: none"> 1. Defective TR05~TR07 on F-2549 2. T04, VR03 on F-2549 out of adjustment 3. TR10, TR11 opens
11) Stereo indicator does not light up	Indicator circuit inoperative	<ol style="list-style-type: none"> 1. Defective TR04, TR05 on F-2549 2. T04, VR03 on F-2549 out of adjustment 3. TR09 on F-2549 opens 4. Stereo indicator lamp, PL707 opens

6. PARTS LOCATION AND PARTS LIST

6-1. F-2546 Power Supply Circuit Board (Stock No. 7501281 MODEL A)
 (Stock No. 7501271 MODEL B)

Conductor Side

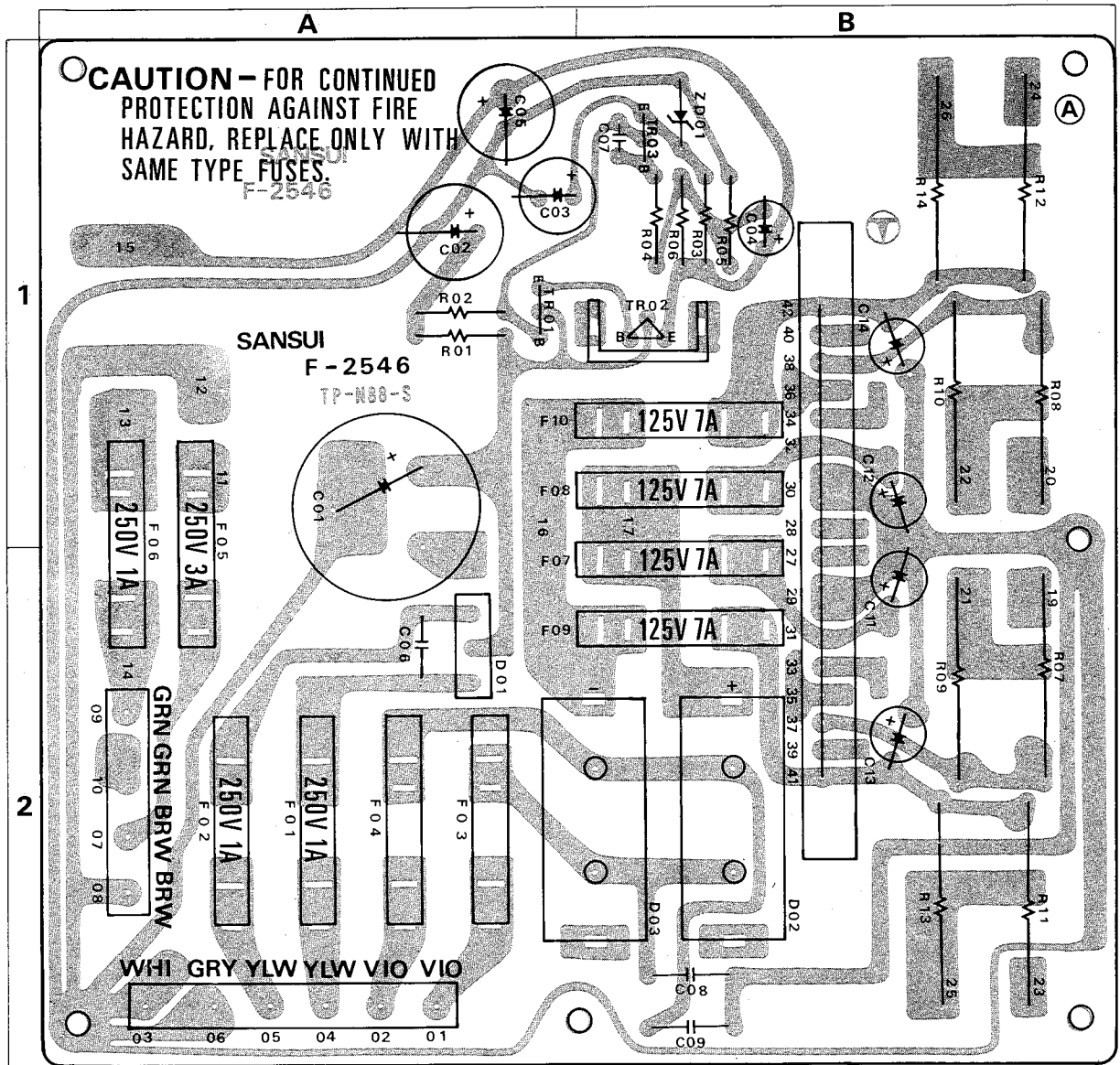

Parts List

Parts No.	Stock No.	Description	Position	Parts No.	Stock No.	Description	Position	Parts No.	Stock No.	Description	Position
TR01	0305930, 1	2SC1211 (C, D)	1 A	C07	0657221	220pF 50V C.C.	1 B	R10	0135338	0.33Ω 5W Ce.R.	1 B
TR02	0306390, 2	2SD313 (C, D, E)	1 B	C08	0655103	10000pF 500V C.C.	2 B	R01	0152220	22Ω 2W	
TR03	0305930, 1	2SC1211 (C, D)	1 B	C09	0655103	10000pF 500V C.C.	2 B	F01, 02	0431220	AC Fuse 1A	2 A
D01	0310530	1S1850	2 A	C11	0539001	4.7μF	2 B	F05	0431260	AC Fuse 3A	
	0310800	10DC2		C12	0539001	4.7μF	1 B	F06	0431220	AC Fuse 1A	
	0311420	C08P-2-N		C13	0539001	4.7μF	2 B	01	2310050	P Type Fuse Holder	
	0311310	SS-5		C14	0539001	4.7μF	1 B	01	2310150	P Type Fuse Holder T-1	
D02	0311310	SS-5	2 B	R01	0107332	3.3kΩ	1 A	01	2420170, 1	18P Multi Connector	
D03	0311320	SS-5R	2 A, B	R02	0107332	3.3kΩ	1 A	*MODEL A only			
ZD01	0315970	EQA01-13R	1 B	R03	0107472	4.7kΩ	1 B	R11-14	0135338	0.33Ω 5W Ce.R.	1, 2 B
C01	0549206	1000μF 63V E.C.	1, 2 A	R04	0107102	1Ω	1/4W C.R.	F07, 08	0431290	AC Fuse 6A	2 A, 1 A
	C02	0515221	220μF 50V E.C.	R05	0107223	22kΩ	1 B	*MODEL B only			
C03	0512101	100μF 16V E.C.	1 A, B	R06	0107333	33kΩ	1 B	F07, 10	0431280	AC Fuse 5A	2 A, 1 A
C04	0515470	47μF 50V E.C.	1 B	R07	0135338	0.33Ω	2 B				
C05	0515101	100μF 50V E.C.	1 A	R08	0135338	0.33Ω	5W Ce.R.				
C06	0655103	10000pF 500V C.C.	2 A	R09	0135338	0.33Ω	2 B				

Note: In parts list above, there are two model numbers as model A and B.
 Regarding name of model A, B, please refer to "Notes" indicated on page 1.

6-2. F-2547 Protector Circuit Board (Stock No. 7593111)

Conductor Side

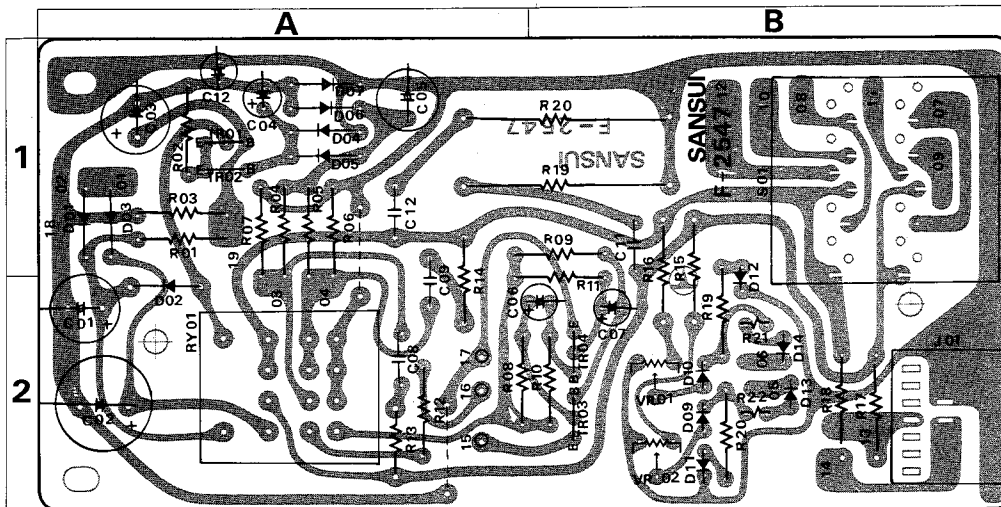

Parts List

Parts No.	Stock No.	Description	Position	Parts No.	Stock No.	Description	Position	Parts No.	Stock No.	Description	Position
TR01	{0305951, 3	25C945 (Q. P. K)	1 A	D13, 14	{0310970	1N60P	2 B	R03	0107223	22kΩ	1 A
	{0306131, 3	25C1364 (6, 7, 8)			{0311060	1N60-P			R04, 05	0107473	47kΩ
TR02	{0305951, 3	25C945 (Q. P. K)	1 A	LD01	0319040	GL-40RG8 L.E.D	2 B	R06, 07	0107432	3.3kΩ	1/4W C.R.
	{0306131, 3	25C1364 (6, 7, 8)			C01	0513330			33μF 25V E.C.	R08	0107152
TR03	{0305951, 3	25C945 (Q. P. K)	2 B	C02		0514221	220μF 35V E.C.	2 A	R09, 10	0107224	220kΩ
	{0306131, 3	25C1364 (6, 7, 8)			C03	0510471	470μF 6.3V E.C.	2 A		R11	0107152
TR04	{0305951, 3	25C945 (Q. P. K)	2 B	C04		0515109	1μF 50V E.C.	1 A	R12	0107152	1.5kΩ
	{0306131, 3	25C1364 (6, 7, 8)			C05	0530470	47μF 6.3V E.C.	1 A	R13, 14	0201100	10Ω
D01	0310340	10D1	1 A	C06		0515109	1μF 50V E.C.	1 A	R15, 16	0201101	100Ω
	D02	0310340	10D1		2 A	C07	0515109	1μF 50V E.C.	2 B	R17, 18	0155221
D03	0310340	10D1	1 A	C08	0601108		0.1μF	2 B	R19, 20	0133100	10Ω
	D04	0310330	1N60		1 A	C09	0601108	0.1μF		2 A	R21, 22
D05	0310330	1N60	1 A	C10	0601108		0.1μF	1, 2 A	R23, 24	0107102	1kΩ
	D06	0310330	1N60		1 A	C11	0601108	0.1μF		1 A	RL01
D07	0310330	1N60	1 A	C12	0535109		1μF 50V E.C.	1 B	{1150280	Relay	
	D08, 09	{0310970	1N60P		2 B	R01	0107104	100kΩ	1/4W C.R.	VR01, 02	1035110
D11, 12		{0311160	1S2473D	2 B	R02		0107100	10Ω	1/2W C.R.		1102650
		{0306131, 3	25C1364 (6, 7, 8)								

6-3. F-2543 Tone Control Circuit Board (Stock No. 7561171)

Conductor Side

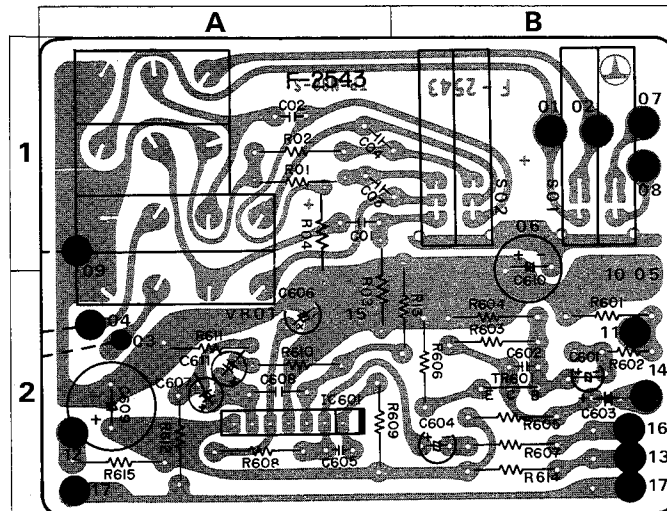

Parts List

Parts No.	Stock No.	Description	Position	Parts No.	Stock No.	Description	Position	Parts No.	Stock No.	Description	Position		
TR601	0306070-2	25C1313 (F, G, H) Transistor		C01, 02	0620471	470pF 50V P.C.	1 A	VR01	1060320, 1	250kΩ BX2	1, 2 A		
IC601	0360190	BA312 IC	2 A		C03, 04	0600277	0.027μF 50V M.C.		1 A	S01	1171120	Lever Switch	1 B
						C601	0600687		0.068μF 50V M.C.		2 B		

6-4. F-2436 Driver Circuit Board (Stock No. 7571201)

Conductor Side

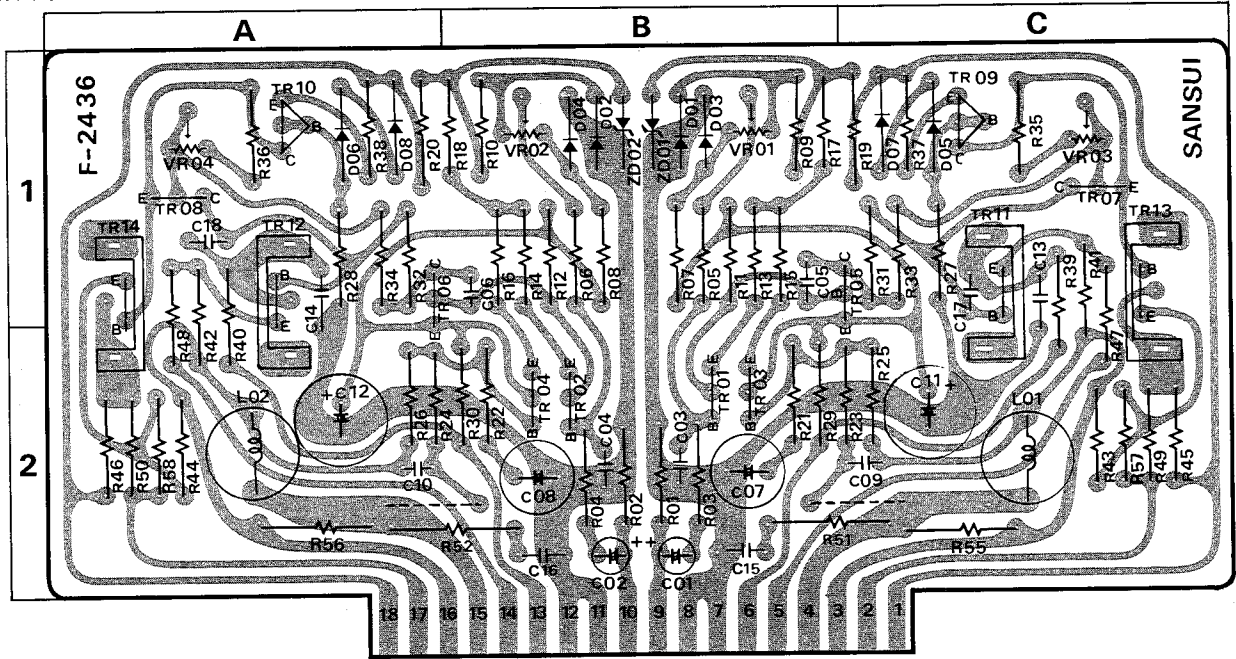

Parts List

Parts No.	Stock No.	Description	Position	Parts No.	Stock No.	Description	Position	Parts No.	Stock No.	Description	Position	
TR01,02	0306271	2SC1708 (G)	2 B	C03,04	0657101	100pF 50V C.C.	2 B	R25,26	0107124	120kΩ	2 D, 2 A	
TR03,04	0306271	2SC1708 (G)		2 B	C05,06	0657150	15pF 50V C.C.	1 B	R27,28	0107333	33kΩ	1 C, 1 A
TR05,06	0300700,1	2SA818 (O, Y)	1.2C, 1.2A	C07,08	0530101	100μF 6.3V E.C.	2 B	R29,30	0191391	390Ω	1/2W Fuse Resistor	2 B, 2 A
	0300801,2	2SA849 (B, V)		C11,12	0519903	100μF 80V E.C.	2 C, 2 A	R31,32	0107390	39Ω	1/2W Fuse Resistor	1 C, 1 A
TR07,08	0305871,2	2SC984 (B, C)	Transistor 1 C, 1 A	C13,14	0651333	33000pF 50V C.C.	1.2C, 1.2A	R33,34	0107332	3.3kΩ	1/2W C.R.	1 C, 1 A
TR09,10	0306260,1	2SC1628 (O, Y)		1 C, 1 A	C15,16	0601108	0.1μF 50V M.C.	2 B	R35,36	0107152	1.5kΩ	1 C, 1 A
TR11,12	0306411,2	2SC1720 (B, V)	1.2C, 1.2A	C17,18	0657101	100pF 50V C.C.	1 C, 1 A	R37,38	0107181	180Ω	1/2W C.R.	1 C, 2 A
	0308531,2	2SD381 (2) (M, L)		1.2C, 1.2A	R01,02	0107124	120kΩ	2 B	R39,40	0191100	10Ω	1/2W Fuse Resistor
TR13,14	0303371,2	2SB536 (2) (M, L)	1.2C, 1.2A	R03,04	0107103	10kΩ	2 B	R41,42	0107151	150Ω	1/2W C.R.	1.2C, 1.2A
D01,02	0311160	1S2473D	1 B	R05,06	0107124	120kΩ	1 B	R43,44	0191220	22Ω	1/2W Fuse Resistor	2 C, 2 A
	0311180	1S1588		R07,08	0107683	68kΩ	1 B	R45,46	0107151	150Ω	1/2W C.R.	2 C, 2 A
	0311160	1S2473D		R09,10	0107223	22kΩ	1/2W C.R.	R47,48	0191479	4.7Ω	1/2W Fuse Resistor	1.2C, 1.2A
D03,04	0311180	1S1588	1 B	R11,12	0107102	1kΩ	1 B	R49,50	0191479	4.7Ω	1/2W Fuse Resistor	2 C, 2 A
D05,06	0340120	VD1212	Varistor 1 C, 1 A	R13,14	0107220	22Ω	1 B	R51,52	0153100	10Ω	3W Ce.R.	2B,C,2A,B
ZD01,02	0315850	EGA01-09	1 B	R15,16	0107220	22Ω	1 B	R001,02	0107183	18kΩ	1/2W C.R.	
	0315860	EGA01-09R		R17,18	0107332	3.3kΩ	1 B	VR01,02	1035350	4.7kΩ(B) DC OV Adjust Volume	1 B	
	0315870	EGA01-09S		R19,20	0201822	8.2kΩ	1W C.R.	VR03,04	1035310	1kΩ(B) Bias Current Adjust Volume	1 C, 1 A	
C01,02	0519103	0.47μF 50V E.C.	2 B	R21,22	0107182	1.8kΩ	1/2W C.R.					
				R23,24	0107274	270kΩ	2 D, 2 A					

6-5. F-2545 Filter & Muting Circuit Board (Stock No. 7593091)

Conductor Side

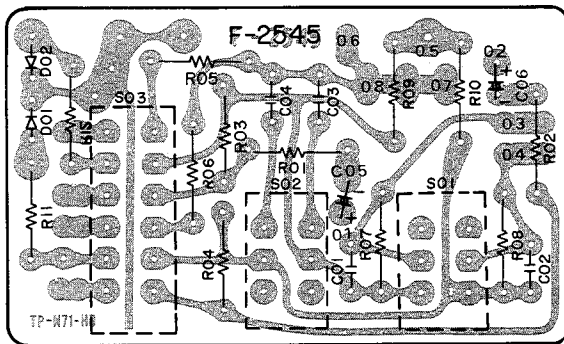

Parts List

Parts No.	Stock No.	Description
D01,02	0311160	1S2473D
	0311180	1S1588
	0310970	1N60P
	0311060	1N60-P
D03,04	0310970	1N60P
	0311060	1N60-P
C01,02	0600187	0.018μF 50V M.C.
C03,04	0600187	0.018μF 50V M.C.
C05,06	0519105	2.2μF 50V E.C.
R01,02	0107332	3.3kΩ
R03,04	0107273	27kΩ
R05,06	0107332	3.3kΩ
R07,08	0107824	820kΩ
R09,10	0107153	15kΩ
S01	1131170	Push Switch

6-6. F-2541 Equalizer Circuit Board (Stock No. 7550731)

Conductor Side

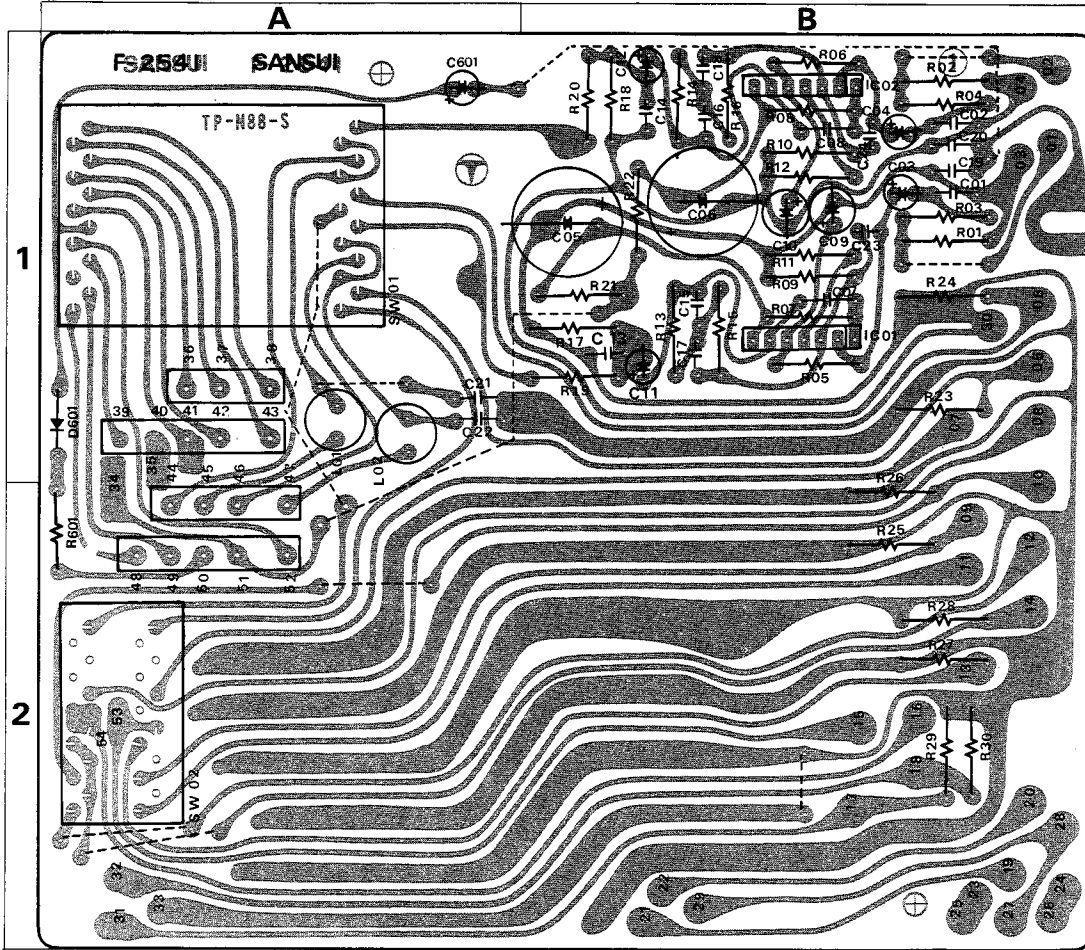

Parts List

Parts No.	Stock No.	Description	Position	Parts No.	Stock No.	Description	Position	Parts No.	Stock No.	Description	Position
IC01, 02	0360190	BA312 IC	1 B	C19, 20	0657473	47000pF 50V C.C.	1 B	R19, 20	0107221	220Ω	1 B
D601	{0311160	{1S2473D	1 A	C21, 22	0600826	0.0082μF 50V M.C.	1 A	R21, 22	0107681	680Ω	1 B
	{0311180	{1S1588		Diode	C23, 24	0657220	22pF 50V C.C.	1 B	R23, 24	0107224	220kΩ
C01, 02	0657470	47pF 50V C.C.	1 B	C601	0515109	1μF 50V E.C.	1 A	R25, 26	0107224	220kΩ	2 B
C03, 04	{0519102	{3.3μF 50V E.C.	1 B	C901	{0515109	{1μF 50V E.C.	1 B	R27, 28	0107224	220kΩ	2 B
	{0573339	{3.3μF 35V T.C.		C05, 06	0515471	470μF 50V E.C.		1 B	R29, 30	0107224	220kΩ
C07, 08	0657470	47pF 50V C.C.	1 B	R01, 02	0107563	56kΩ	1 B	R01	0107223	22kΩ	2 B
C09, 10	0510470	47μF 6.3V E.C.	1 B	R03, 04	0107472	4.7kΩ	1 B	L01, 02	4900090	Inductor	1 A
C11, 12	{0519101	{1μF 50V E.C.	1 B	R05, 06	0107823	82kΩ	1 B		S01	1103550	Rotary Switch
C13, 14	{0573109	{330pF 50V C.C.		1 B	R07, 08	0107394	390kΩ	1 B	S02	1102660	Rotary Switch
	0657331	330pF 50V C.C.	R09, 10		0107821	820Ω	1 B	2410570	5P Pin Assy Type D		
C15, 16	0600276	0.0027μF 50V M.C.	1 B	R11, 12	0107330	33Ω	1 B	2410580	3P Pin Assy Type D		
C17, 18	0600107	0.01μF 50V M.C.	1 B	R13, 14	0107273	27kΩ	1 B	2410590	4P Pin Assy Type D		
				R15, 16	0107334	330kΩ	1 B				
				R17, 18	0107224	220kΩ	1 B				

6-7. F-2431 Power Supply Circuit Board (Stock No. 7501301)

Conductor Side

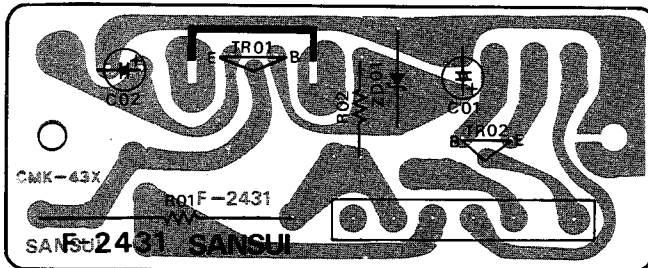

Parts List

Parts No.	Stock No.	Description
TR01	0308390-2	2SD313 (C, D, E) Transistor
D901	0310340	10D1
ZD01	0315970	EQA01-13R
C01	0512221	220μF 16V E.C.
C02	0512101	100μF 16V E.C.
C901	0511471	470μF 10V E.C.
R01	0183391	390Ω 3W Ce.R.
R02	0107472	4.7kΩ 1/4W C.R.
R03	0183391	390Ω 3W Ce.R.

6-10. F-2549 FM, AM Tuner Circuit Board (Stock No. 7593171)

Conductor Side

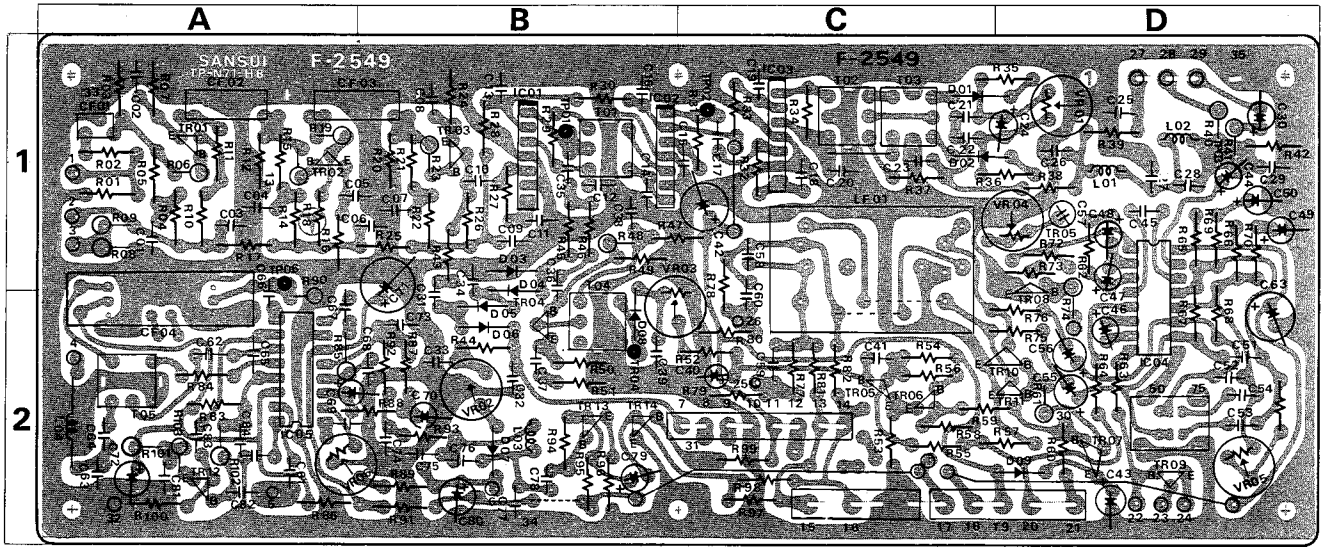

Parts List

Parts No.	Stock No.	Description	Position	Parts No.	Stock No.	Description	Position	Parts No.	Stock No.	Description	Position		
TR01	0306113	25C738 (D)	1 A	C24	0512100	410 μ F 16V E.C.	1 D	R07	0113122	1.2k Ω	1/4 W S.R.	1 A	
TR02	0306113	25C738 (B)	1 A	C25	0657223	22000pF 50V C.C.	1 D	R08	0106333	33k Ω	1/4 W C.R.	1 A	
TR03	0306112	25C738 (C)	1 B	C26	0620181	180pF 50V P.C.	1 D	R09	0106104	100k Ω	1/4 W S.R.	1 A	
TR04	0306112, 3	25C738 (C, D)	2 B	C27	0620331	330pF 50V P.C.	1 D	R10	0113331	330 Ω	1/4 W S.R.	1 A	
TR05	0305731, 2	25C711 (E, F)	2 C	C28	0620101	100pF 50V P.C.	1 D	R11	0113101	100 Ω	1/4 W S.R.	1 A	
TR06	0305731, 2	25C711 (E, F)	2 C	C29	0620151	150pF 50V P.C.	1 D	R12	0113332	3.3k Ω	1/4 W S.R.	1 A	
TR07	0300281, 2	25A628 (D, E)	2 D	C31	0657221	220pF	1, 2 B	R13	0113471	470 Ω	1/4 W S.R.	1 A	
TR08	0305731	25C711 (E)	1, 2 D	C32	0657221	220pF	2 B	R14	0113102	1.0k Ω	1/4 W S.R.	1 A	
TR09	0300221	25A562 (Y)	2 D	C33	0657223	22000pF	2 B	R15	0106151	150 Ω	1/4 W C.R.	1 A	
TR10, 11	0305371	25C733 (Y)	2 D	C34	0657221	220pF	1, 2 B	R16	0113122	1.2k Ω	1/4 W S.R.	1 A	
	0305641	25C735 (Y)	2 D	C35	0657102	1000pF 50V C.C.	1 B	R17	0113479	4.7k Ω	1/4 W S.R.	1 A	
TR12	0300281	25A628 (D)	2 A	C36	0657102	1000pF	1, 2 B	R18	0113331	300 Ω	1/4 W S.R.	1 A	
TR13	0306091	25C1312R (G)	2 B	C37	0657223	22000pF	2 B	R19	0106101	100 Ω	1/4 W C.R.	1 A	
TR14	0305371	25C733 (Y)	2 B	C38	0657223	22000pF	1 B	R20	0113222	2.2k Ω	1/4 W S.R.	1 B	
				C39	0657101	100pF	2 B	R21	0113471	470 Ω	1/4 W S.R.	1 B	
IC01	0360120	μ PC555H	1 B	C40	0519101	1 μ F 50V E.C.	2 C	R22	0113562	5.6k Ω	1/4 W C.R.	1 B	
IC02	0360120	μ PC555H	1 B	C41	0657221	220pF 50V C.C.	2 C	R23	0106221	220 Ω	1/4 W C.R.	1 B	
IC03	0360120	μ PC555H	1 C	C42	0512470	47 μ F 16V E.C.	1 C	R24	0113391	390 Ω	1/4 W S.R.	1 B	
IC04	0360320	HA1196	1, 2 D	C44	0573688	0.68 μ F 35V T.C.	1 D	R25	0113476	4.7k Ω	1/4 W S.R.	1 B	
IC05	0360150	HA-1151	2 A	C45	0600477	0.04 μ F 50V M.C.	1 D	R26	0113102	1.0k Ω	1/4 W S.R.	1 B	
				C46	0573228	0.22 μ F 35V T.C.	2 D	R27	0113102	1.0k Ω	1/4 W S.R.	1 B	
D01	0311060	1N60-P	2 C, B	C47	0519104	1.5 μ F 50V E.C.	1 D	R28	0113479	4.7k Ω	1/4 W S.R.	1 B	
D02	0311060	1N60-P	2 C, B	C48	0519102	3.3 μ F 50V E.C.	1 D	R29	0113103	10k Ω	1/4 W S.R.	1 B	
D03	0310330, 1	1N60	1 B	C49, 50	0512100	10 μ F 16V E.C.	1 D	R30	0113479	4.7k Ω	1/4 W S.R.	1 B	
D04	0310330, 1	1N60	1, 2 B	C51, 52	0600126	0.0012 μ F 50V M.C.	2 D	R31	0113102	1.0k Ω	1/4 W S.R.	1 C	
D05	0310330, 1	1N60	2 B	C53, 54	0620511	510pF 50V P.C.	2 D	R32	0113102	1.0k Ω	1/4 W S.R.	1 C	
D06	0310330, 1	1N60	2 B	C55, 56	0519101	1 μ F 50V E.C.	2 D	R33	0113479	4.7k Ω	1/4 W S.R.	1 C	
D07	0310330, 1	1N60	2 B	C57	0629005	360pF 50V P.C.	1 D	R34	0113682	6.8k Ω	1/4 W S.R.	1 C	
D08	0310330, 1	1N60	2 B	C59, 60	0600186	0.0018 μ F 50V M.C.	1, 2 C	R35	0113102	1.0k Ω	1/4 W S.R.	1 C D	
D09	0311160	1S2473D	2 B	C62	0657103	10000pF 50V C.C.	2 A	R36	0113102	1.0k Ω	1/4 W S.R.	1 C D	
	0311180	1S1583		C63	0669400	15pF 50V C.C.	2 D	R37	0113101	100 Ω	1/4 W S.R.	1 C	
D10	0311160	1S2473D		C64	0620361	360pF 50V P.C.	2 A	R38	0113471	470 Ω	1/4 W S.R.	1 D	
	0311180	1S1588		C66	0657103	10000pF	1, 2 A	R39	0113153	15k Ω	1/4 W S.R.	1 D	
D11	0311160	1S2473D		C67	0657102	10000pF	50V C.C.	R42	0113103	10k Ω	1/4 W S.R.	1 D	
	0311180	1S1588		C68	0657102	10000pF	2 B	R43	0113102	1.0k Ω	1/4 W S.R.	1 B	
				C69	0515339	3.3 μ F 50V E.C.	2 A, B	R44	0113222	2.2k Ω	1/4 W S.R.	2 B	
C01	0657223	22000pF	1 A	C70	0512100	10 μ F 16V E.C.	2 B	R45	0113102	1.0k Ω	1/4 W S.R.	1 B	
C02	0657223	22000pF	1 A	C71	0512101	100 μ F 16V E.C.	1, 2 B	R46	0113332	3.3k Ω	1/4 W S.R.	1 B	
C03	0657223	22000pF	1 A	C72	0512470	47 μ F 16V E.C.	2 A	R47	0113222	2.2k Ω	1/4 W S.R.	1 B C	
C04	0657223	22000pF	1 A	C73	0600337	0.033 μ F 50V M.C.	2 B	R48	0106183	18k Ω	1/4 W C.R.	1 B	
C05	0657223	22000pF	1 A, B	C74	0600337	0.033 μ F 50V M.C.	2 B	R49	0113103	10k Ω	1/4 W S.R.	1 B	
C06	0657223	22000pF	1 A, B	C75	0600107	0.01 μ F 50V M.C.	2 B	R50	0113102	1.0k Ω	1/4 W S.R.	2 B	
C07	0657223	22000pF	1 B	C76	0600107	0.01 μ F 50V M.C.	2 B	R51	0113820	82 Ω	1/4 W S.R.	2 B	
C08	0657223	22000pF	1 B	C77	0600227	0.022 μ F 50V M.C.	2 B	R52	0113683	68k Ω	1/4 W S.R.	2 C	
C09	0657223	22000pF	1 B	C78	0600157	0.015 μ F 50V M.C.	2 B	R53	0113820	82 Ω	1/4 W S.R.	2 C	
C10	0657102	1000pF	1 B	C79	0519101	1 μ F 50V E.C.	2 B	R54	0113473	47k Ω	1/4 W S.R.	2 C	
C11	0657223	22000pF	1 B	C80	0510470	47 μ F 6.3V E.C.	2 B	R56	0113104	100k Ω	1/4 W S.R.	2 C	
C12	0657223	22000pF	1 B	C81	0657223	22000pF	2 A	R57	0113104	100k Ω	1/4 W S.R.	2 C D	
C13	0657223	22000pF	1 B	C82	0657102	1000pF	2 A	R58	0113562	5.6k Ω	1/4 W S.R.	2 C	
C14	0657223	22000pF	1 B	C83	0657331	330pF 50V C.C.	2 A	R59	0113333	33k Ω	1/4 W S.R.	2 C D	
C15	0657223	22000pF	1 C	C84	0657223	22000pF	2 A	R61	0106472	4.7k Ω	1/4 W C.R.	2 D	
C16	0657223	22000pF	1 B	C85	0512470	47 μ F 16V E.C.		R62	0113102	1.0k Ω	1/4 W S.R.	1 D	
C17	0657102	1000pF	1 C					R63	0113221	220 Ω	1/4 W S.R.	2 D	
C18	0657223	22000pF	1 C					R64	0113104	100k Ω	1/4 W S.R.	2 D	
C19	0657223	22000pF	1 C	R01	0113102	1.0k Ω	1 A	R65, 66	0113273	27k Ω	1/4 W S.R.	1 D	
C20	0657223	22000pF	1 C	R02	0113101	100 Ω	1 A	R67, 68	0113473	47k Ω	1/4 W S.R.	1, 2 D	
C21	0657151	150pF	1 C	R03	0113332	3.3k Ω	1/4 W S.R.	1 A	R69, 70	0113682	6.8k Ω	1/4 W S.R.	1 D
C22	0657151	150pF	1 C	R04	0113102	1.0k Ω	1/4 W S.R.	1 A	R71	0113103	10k Ω	1/4 W S.R.	2 D
C23	0657151	150pF	1 C	R05	0113471	470 Ω	1/4 W S.R.	1 A	R72	0107184	180k Ω	1/4 W C.R.	1 D
				R06	0106151	150 Ω	1/4 W C.R.	1 A					

Parts No.	Stock No.	Description	Position
R73	0113151	150Ω ¼W S.R.	1D
R74	0106104	180kΩ ¼W C.R.	1,2D
R75, 76	0113332	3.3kΩ	2D
R77, 78	0113333	33kΩ	1,2C
R79, 80	0113223	22kΩ	2C
R81, 82	0113182	1.8kΩ	2C
R83	0113392	3.9kΩ	2A
R84	0113100	10Ω	2A
R85	0106331	330Ω ¼W C.R.	2A
R86	0113151	150Ω	2A
R87	0113103	10kΩ	2B
R88	0113272	2.7kΩ	2B
R89	0113152	1.5kΩ ¼W S.R.	2B
R90	0106562	5.6kΩ ¼W C.R.	2A
R91	0113101	100Ω	2B
R92	0113182	1.8kΩ	2B
R93	0113102	1.0kΩ ¼W S.R.	2B
R94	0113224	220kΩ	2B
R95	0113561	560Ω	2B

Parts No.	Stock No.	Description	Position
R96	0113221	220Ω	2B
R97, 98	0113332	3.3kΩ ¼W S.R.	2C
R100	0113332	3.3kΩ	2A
R101	0106152	1.5kΩ ¼W	2A
R102	0106473	47kΩ	2A
R103	0106390	39Ω	2A
R104	0106123	12kΩ	2A
R901	0106473	47kΩ ¼W C.R.	2A
R902	0106153	15kΩ	2A
R903	0107273	27kΩ	2A
L01	4900250	Inductor	1D
L02	4900240		1D
L03	4900220		2B
L04	4290011		Choke Coil 2A
T01	4235860	FM IF Coil	1B
T02	4235750		1C
T03	4235760		1C
T04	4235940		2B

Parts No.	Stock No.	Description	Position
T05	4220550	OSC Coil	2A
CF01	0910150	Ceramic Filter	1A
CF02	0910330		1A
CF03	0910330		1A, B
CF04	0910310		1,2A
LF01	0910210	Low Pass Filter	1,2C
VR01	1035150	22kΩ B	1D
VR02	1035170	47kΩ B	2B
VR03	1035170	47kΩ B	1B, C
VR04	1034250	4.7kΩ B	1C, D
VR05	1035210	220kΩ B	2D
VR06	1035110	4.7kΩ B	2A, B
S01	1110270	Slide Switch	
	2410570	5P Pin Assy Type D	
	2410590	4P Pin Assy Type D	
	2410740	8P Pin Assy Type A	

6-11. F-2550 Multi-Path Circuit Board (Stock No. 7593181)

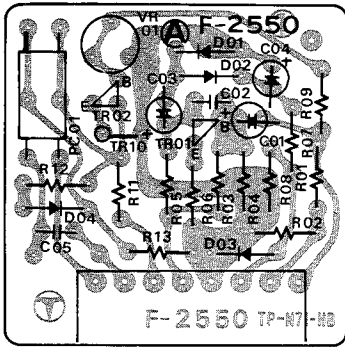

Parts List

Parts No.	Stock No.	Description
TR01	0305731, 2	25C711 (E, F) Transistor
TR02	0305733	25C711 (G) Transistor
D01	0310330, 1	1N60
D02	0310330, 1	1N60
D03	0310330, 1	1N60
D04	0310330, 1	1N60
PC01	0920060	Photo-cell Lamp
C01	0515109	1µF 50V E.C.
C02	0657101	100pF 50V C.C.
C03	0513479	4.7µF 25V E.C.
C04	0512100	10µF 16V E.C.
C05	0600107	0.01µF 50V M.C.

Parts No.	Stock No.	Description
R01	0113473	47kΩ
R02	0113104	100kΩ
R03	0113563	56kΩ
R04	0113103	10kΩ
R05	0113182	1.8kΩ ¼W S.R.
R06	0113331	330Ω
R07	0113392	3.9kΩ
R08	0113223	22kΩ
R09	0113153	15kΩ
R10	0113479	4.7kΩ
R11	0113102	1.0kΩ ¼W S.R.
R12	0113561	560Ω
R13	0113470	47Ω
VR001	1035190	100kΩ B
	2420300	8P Connector Assy Type A

6-12. F-1470 Lamp Circuit Board (Stock No. 7593151)

Parts List

Parts No.	Stock No.	Description
R01	0191180	18Ω ¼W Fuse Resistor
PL01, 04	0420040	7V 320MA

6-13. F-2597 Connector Circuit Board (Stock No. 7593901)

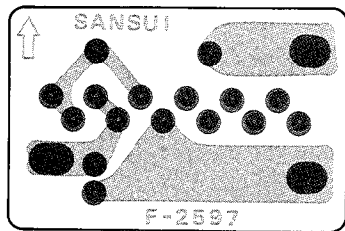

Parts List

Parts No.	Stock No.	Description
C01	0515109	1µF 50V E.C.
R01	0107472	4.7kΩ ¼W C.R.

6-14. F-2548 Protector Connector Circuit Board (Stock No. 7593131)

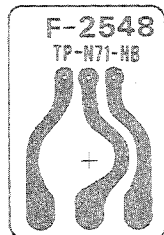

6-15. F-1519 FM Pack (Stock No. 7510650)

Conductor Side

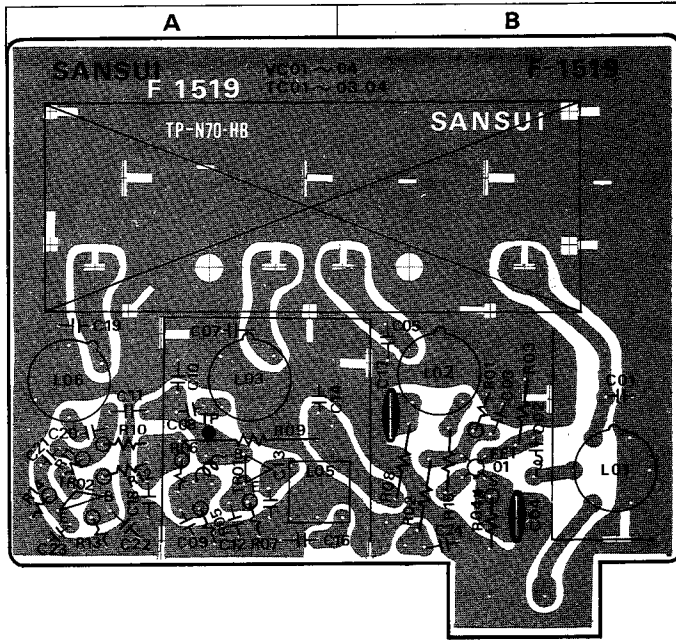

Parts No.	Stock No.	Description	Position
C01	0669342	5.6pF	50V C.C.
C02	0657102	1000pF	
C03	0657223	0.022μF	
C04	0659015	2200pF	
C05	0669345	10pF	
C06	0679023	0.39pF	
		500V Gimmick Capacitor	
C07	0669345	10pF	A
C08	0669210	10pF	A
C09	0657102	1000pF	A
C10	0661220	22pF	A
C11	0669202	2.2pF	A
C12	0657223	0.022μF	A
C13	0660121	120pF	A
C14	0657223	0.022μF	A
C16	0660331	330pF	A
C17	0659015	2200pF	B
C18	0657223	0.022μF	A
C19	0669375	15pF	A
C20	0657102	1000pF	A
C21	0669209	8.2pF	A
C22	0657223	0.022μF	A
C23	{0661220 0669221	22pF	A
C24	0657223	0.022μF	B
R01	0106105	1MΩ	1/4W C.R.(E.L.R.)
R02	0113104	100kΩ	B
R03	0113104	100kΩ	1/4W S.R.
R04	{0106101 0106680	100Ω 68Ω	(3SK41(1)K) (3SK41(1)L)
R05	0106682	6.8kΩ	1/4W C.R.(E.L.R.)
R06	0106123	12kΩ	A
R07	0106392	3.9kΩ	A
R08	0113121	120Ω	B
R09	0113271	270Ω	1/4W S.R.
R10	0106392	3.9kΩ	A
R11	0106121	120Ω	A
R12	0106682	6.8kΩ	1/4W C.R.
R13	0106222	2.2kΩ	A
R14	0106182	1.8kΩ	A
R15	0113680	68Ω	1/4W S.R.
	2260010	Test Pin	

Parts List

Parts No.	Stock No.	Description	Position	Parts No.	Stock No.	Description	Position
TR01	0305800, 1	2SC1047 (A, B)	Transistor	L04	4290110	Choke Coil	A
TR02	0305790, 1	2SC930 (C, D)		A	L05	4235910	IF Coil
FET01	0370131, 2	3SK41 (K, L)	FET	L06	4220430	OSC Coil	A
L01	4200640	Antenna Coil	B	VC01-04	1220130	FM, AM Variable Capacitor	A, B
L02	4210330	RF Coil (1)	B	TC01-03			A, B
L03	4210220	RF Coil (2)	A	TC04	1230090	FM OSC Trimmer	A, B

6-16 Figures Semiconductor

SEMICONDUCTORS	COMPLETE CIRCUIT BOARD	SEMICONDUCTORS	COMPLETE CIRCUIT BOARD	SEMICONDUCTORS	COMPLETE CIRCUIT BOARD
2SA849 2SC945 2SC1364	F-2436 F-2547	BA312	F-2541 F-2543 F-2544	1N60 1N60P	F-2545 F-2547 F-2549 F-2552
2SC984	F-2436	μPC555A	F-2431	10D1	F-2431 F-2547
2SA628 2SC711 2SC738D 2SC1312 2SC1313 2SC1708	F-2436 F-2543 F-2544 F-2549 F-2550	HA1151	F-2549	VD1212	F-2436
2SC1720	F-2436	2SA818 2SC1628	F-2436	1S2473D 1S1588	F-2436 F-2541 F-2545 F-2549
2SB536 2SD313 2SD381	F-2431 F-2436	HA1196	F-2549	EQA01-09 EQA01-09R EQA01-09S EQA01-13R	F-2431 F-2436

Connector & Pin Ass'y

Connector

Type A (3~10 pins)	Type B (2~6 pins)	Stock No.
		2 Pins 2420250
		3 Pins 2420220
		4 Pins 2420230
		5 Pins 2420210
		6 Pins 2420240

NOTE: Since stock number of female connectors (type B) with wires are not shown in each parts list of Complete circuit board, please refer to the above parts list when ordering the connector.

Pin Ass'y

Type A (3~10 pins)	Type B (3~10 pins)	Type C (3~10 pins)
Type D (2~6 pins)	Type E (2~6 pins)	Type F (2~6 pins)

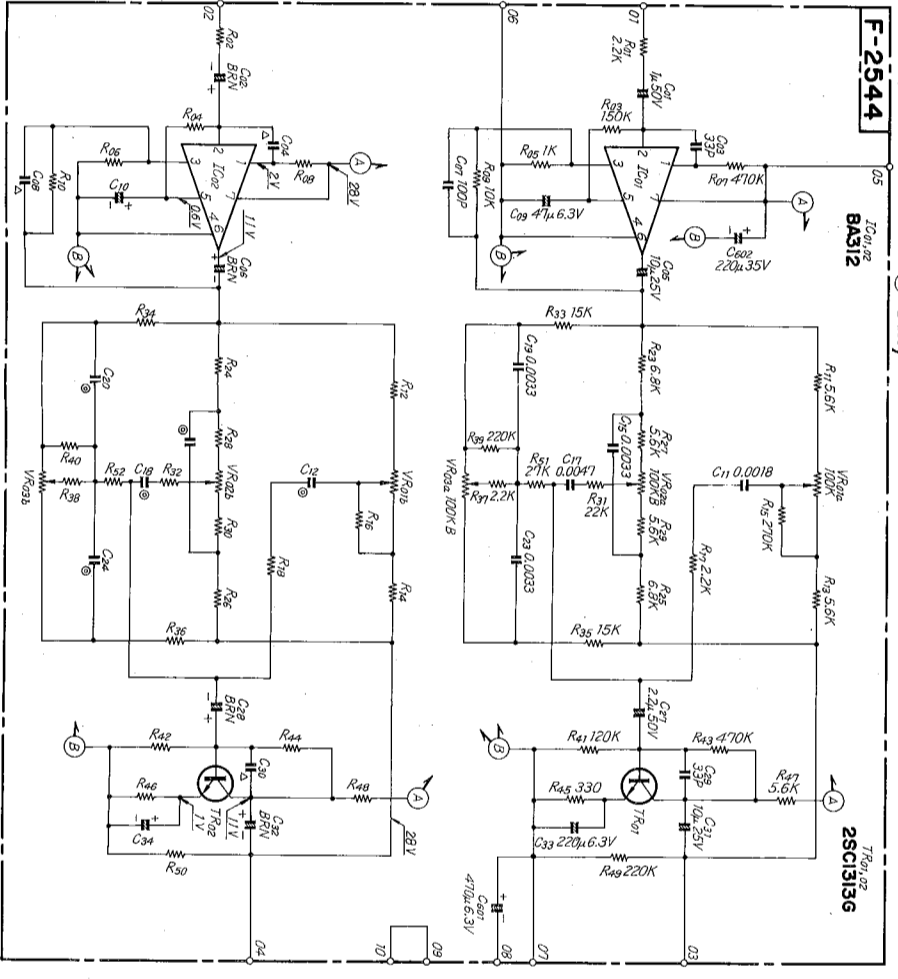
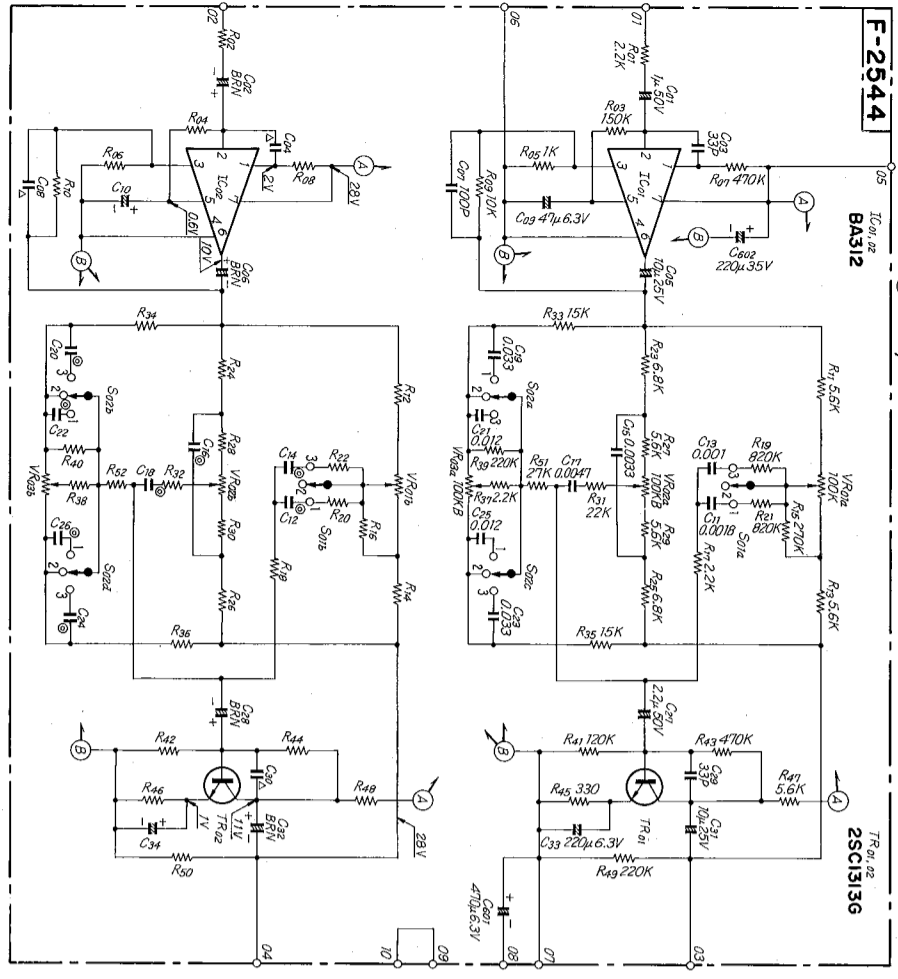
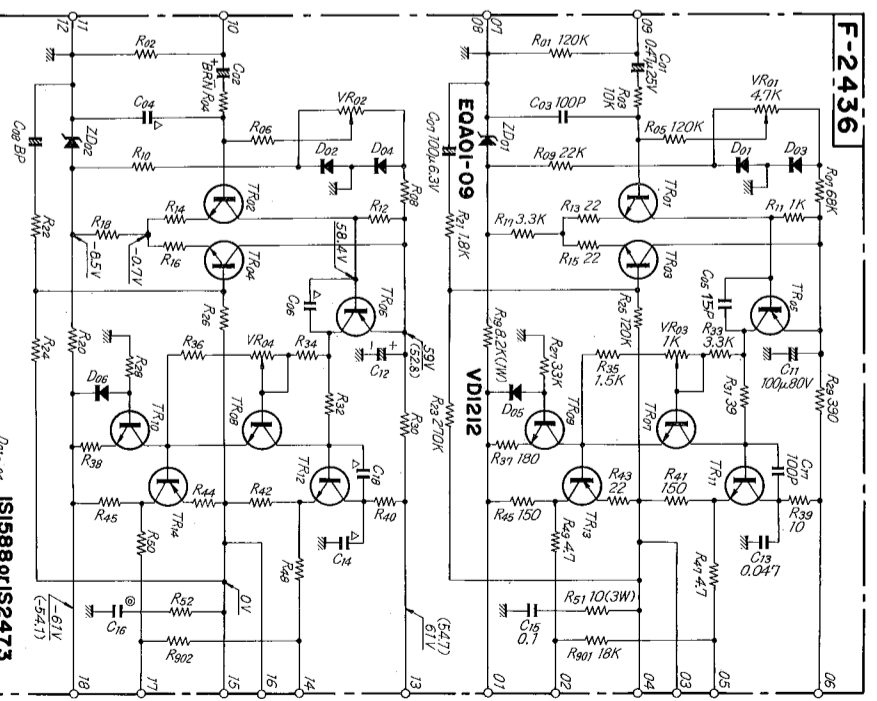
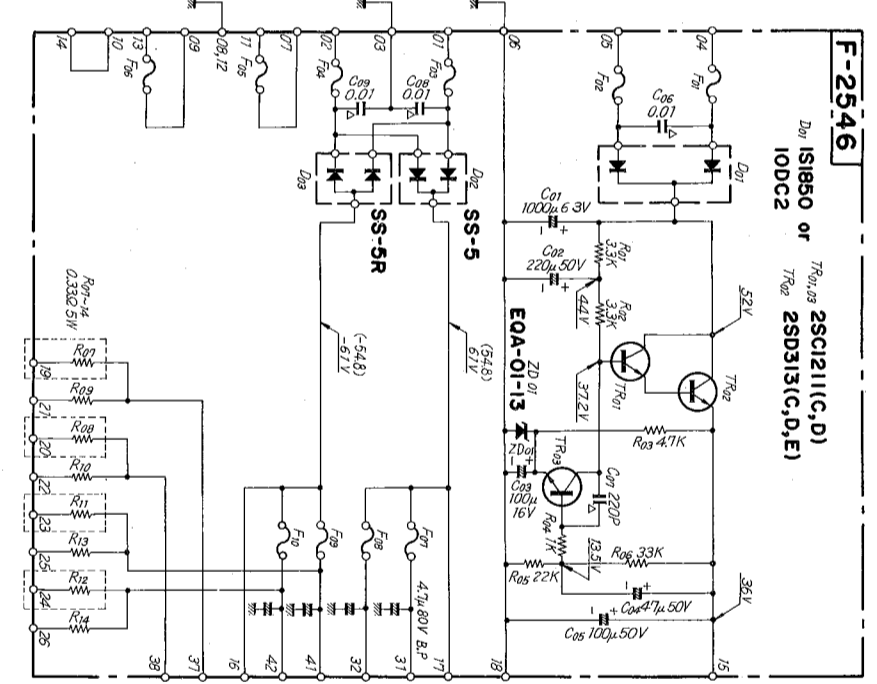
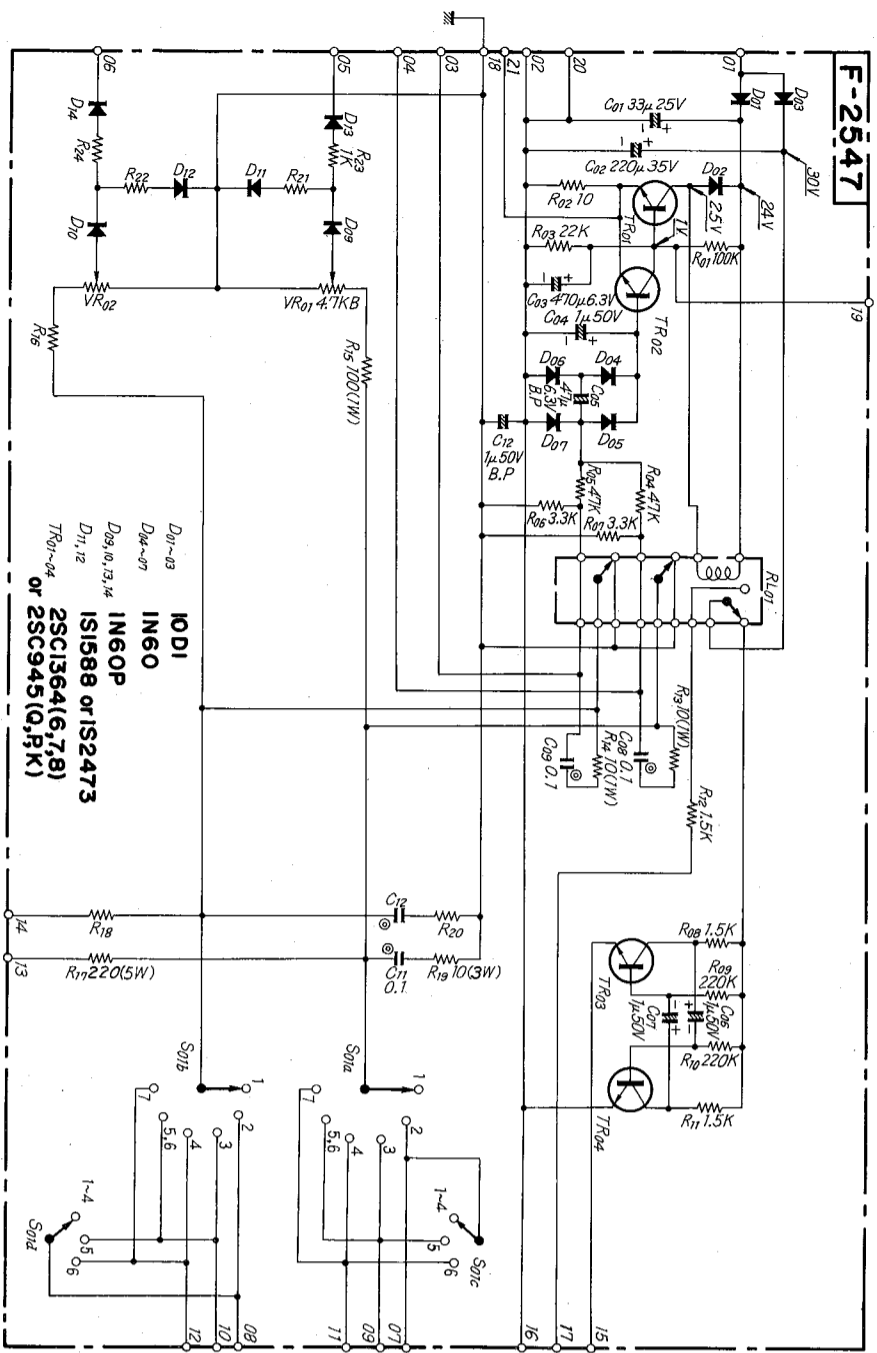

- | | |
|-----------|-----------|
| 1. 1.5KHz | 1. 1.5KHz |
| 2. DEFFAT | 2. DEFFAT |
| 3. 3KHz | 3. 3KHz |
| 1. 300Hz | 1. 300Hz |
| 2. DEFFAT | 2. DEFFAT |
| 3. 150Hz | 3. 150Hz |
| 1. OFF | 1. OFF |
| 2. A | 2. A |
| 3. B | 3. B |
| 4. C | 4. C |
| 5. A+B | 5. A+B |
| 6. A+C | 6. A+C |

Note:

- In model (B), the section in on schematic diagram above are not installed.
- Each voltage in parentheses () shows the value of model (B) in volts.

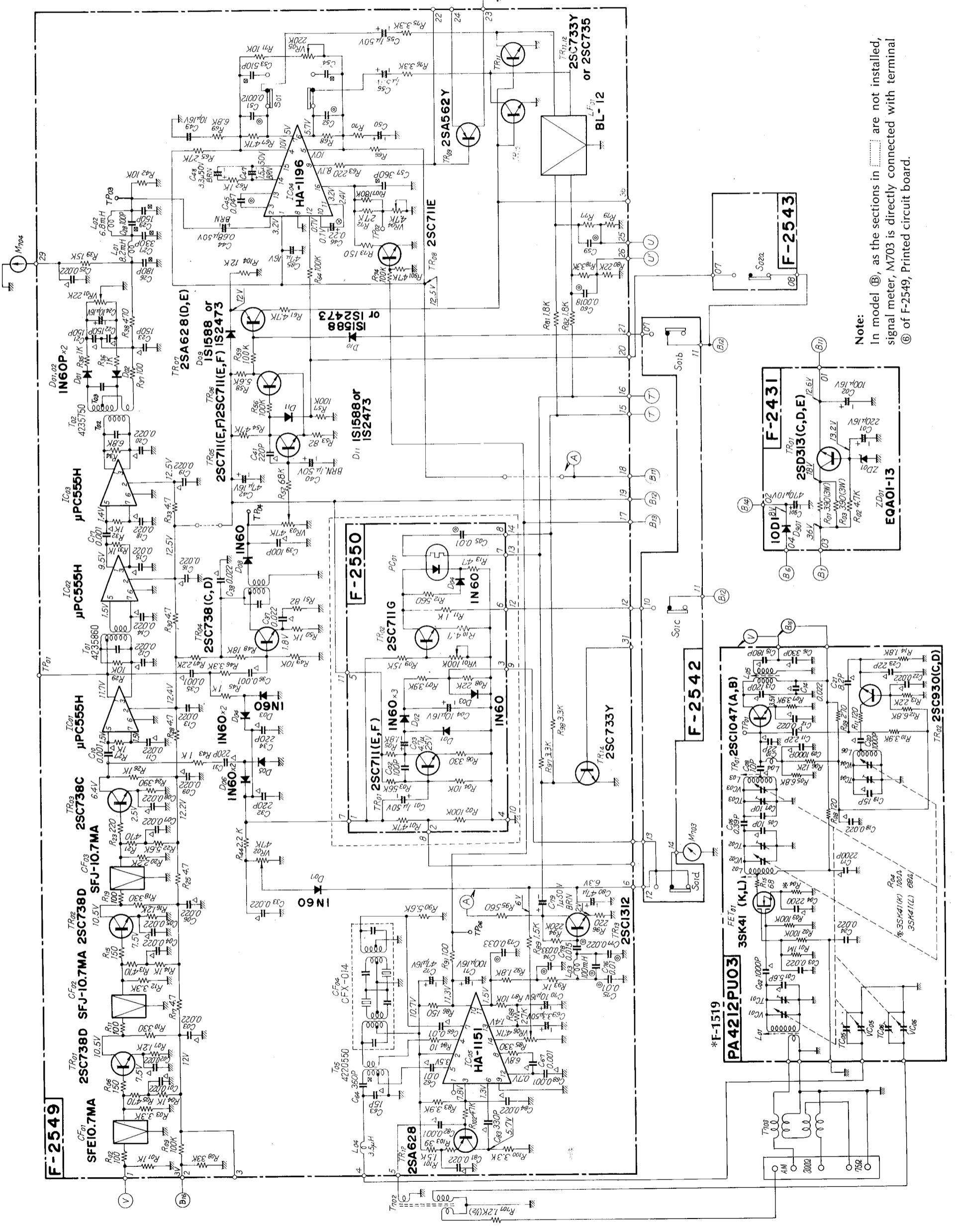

Note:
 In model (B), as the sections in [] are not installed,
 signal meter, M703 is directly connected with terminal
 (B) of F-2549, Printed circuit board.

8. OTHER PARTS 8-1. Other Parts (Top Side)

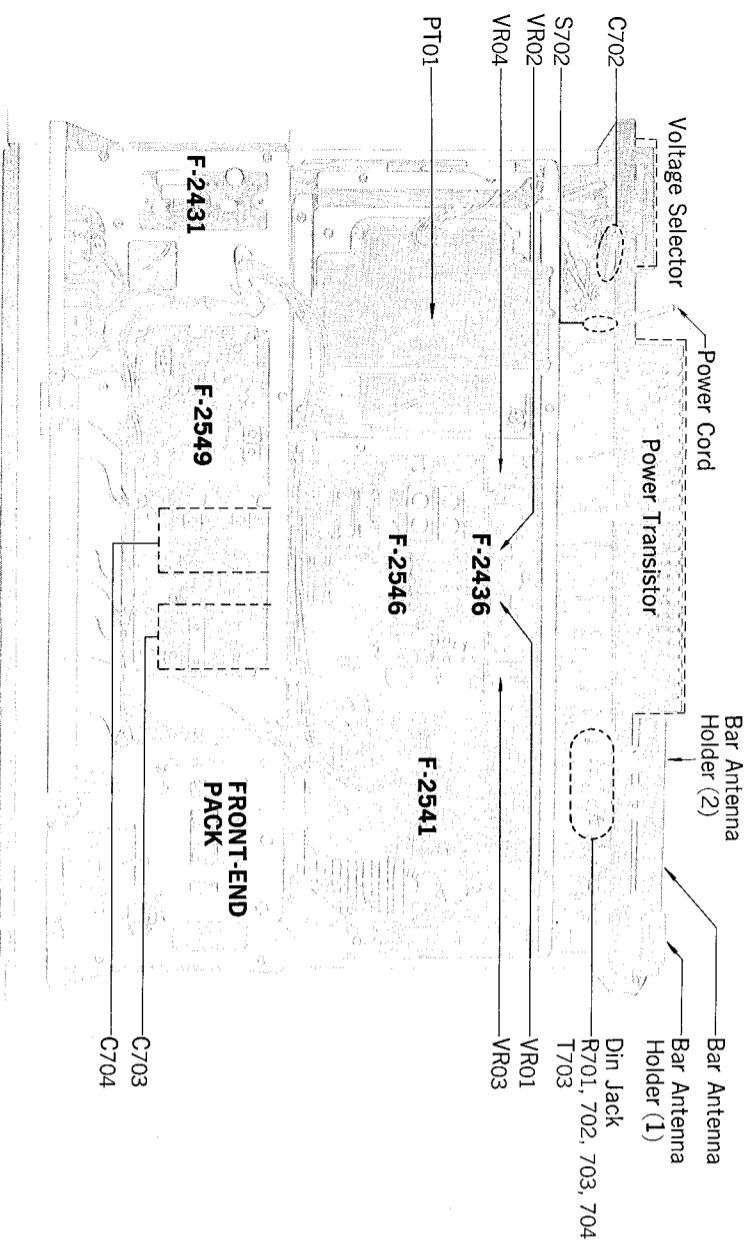

8-2. Other Parts (Front Side)

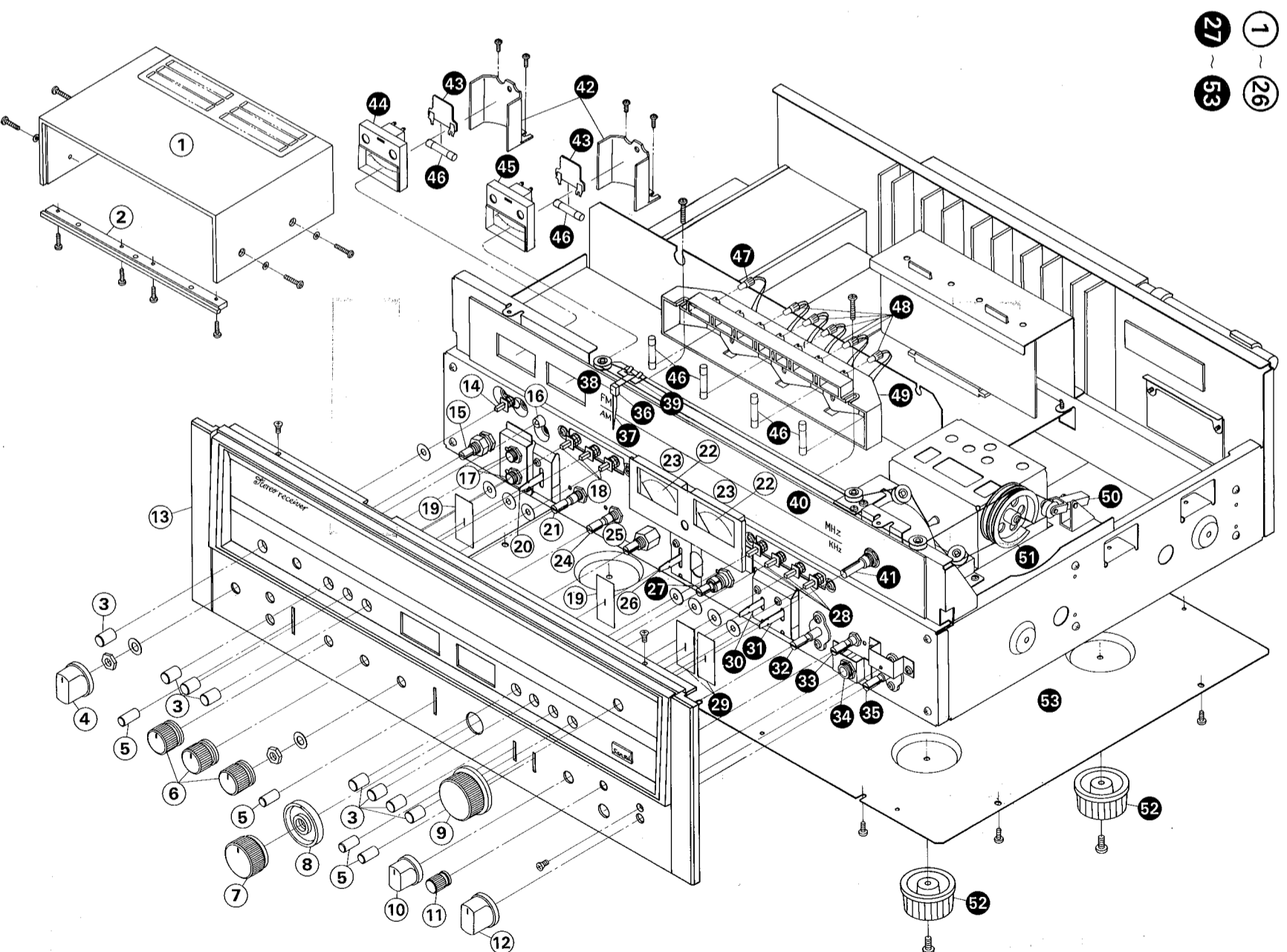

Parts List

Parts No.	Stock No.	Description	Parts No.	Stock No.	Description
PT01	{ 4002340 4002350 }	MODEL (A) } Power Transistor MODEL (B) }	S702	1900020	Thermal Lead Switch
T702	42900760	Bar Antenna	2210190	3P Antenna Terminal	
T703	4290021	Antenna Transformer, 75Ω/300Ω	2200340	8P PRE/MAIN Terminal	
C701	0605337	0.033μF 250V M.C.	2200360	12P Input Terminal	
C702	0605476	0.0047μF 250V M.C.	2290160	4P Output Terminal	
C703, 704	{ 0559843 0559515 }	6800μF 71V E.C. MODEL (A) 6800μF 63V E.C. MODEL (B)	2230051	Ground Terminal	
R701, 702	{ 0113184 0113104 }	180KΩ ¼W S.R. 100KΩ ¼W S.R.	2430040, 1	Din Jack	
R703, 704	{ 0431280 0431320 0431270 0431300 }	5A 250V (AC 220~240V) } MODEL (A) 10A 250V (AC 100~120V) } Power Fuse 4A 250V (AC 220~240V) } MODEL (B) 7A 250V (AC 100~120V) } Power Fuse	2300060	Power Fuse Holder	
R707	0103122	1.2kΩ ½W C.R.	2460010	PRE/MAIN Connector	
			2030040	Power Transistor Socket	
			2450060	AC Outlet	
			2410091	Voltage Selector Plug	
			2410830	Voltage Selector Socket	
			5286600	Voltage Selector Cover	
			{ 3800290 3800261 }	MODEL (A) } Power Cord MODEL (B) }	
			5286450	Bar Antenna Holder (1)	
			5286480	Bar Antenna Holder (2)	

Note: In parts list above, there are two model numbers as model (A) and (B).
Regarding name of model (A), (B), please refer to "Notes" indicated on page 1.

Parts List (Front Side)

Parts No.	Stock No.	Description
1	5726933	MODEL [Ⓐ] Bonnet
	5726923	MODEL [Ⓑ] Bonnet
2	5996092	MODEL [Ⓐ] Panel Sash
	5996102	MODEL [Ⓑ] Panel Sash
3	5326560	Push Knob (B)
4	5318400	E-2 Type Knob MODEL [Ⓐ] } Speakers Knob
	5318380	M-7 Type Knob MODEL [Ⓑ] }
5	7106130	C-2 Type Knob, Lever Switch
6	5318410	S-10 Type Knob, Tone Control Knob
7	5318440	WI-6 Type Knob, Volume
8	5318431	WO-8 Type Knob, Balance
9	5318420	T-12 Type Knob, Tuning
10	5318390	E-1 Type Knob MODEL [Ⓐ] } Tape Copy
	5318410	S-10 Type Knob MODEL [Ⓑ] } Switch
11	5318340	N-6 Type Knob, MIC Level
12	5318400	E-2 Type Knob MODEL [Ⓐ] } Selector Knob
	5318380	M-7 Type Knob MODEL [Ⓑ] }
13	7007230	MODEL [Ⓐ] Front Panel
	7007240	MODEL [Ⓑ] Front Panel
14	1131190	Power Switch
15	1102650	Speakers Switch
16	0319040	LED Ass'y
17	2430200	Head phone Jack
18	1131170	Push Switch
19	5047470	Masking, Lever Switch
20	1171220	Bass Selector MODEL [Ⓐ] only
21	1010930	Bass Volume, 100kΩB
22	4300920	Power Meter
23	7726040	Power Meter Circuit Board
24	1010930, 1	Midrange Volume, 100kΩB
25	1010930, 1	Treble Volume, 100kΩB
26	1171240	Treble Selector MODEL [Ⓐ] only
27	1060320, 1	Master & Balance Volume, 250kΩ MN
28	1131180	Push Switch
29	5047470	Masking, Lever Switch
30	1171120	Loudness Switch
31	1171120	MODE Switch
32	1102660	Tape Copy Switch
33	1005170, 1	MIC Volume, 20kΩ
34	2430170	MIC Jack
35	1103550	Selector
36	5416350	Holder, Dial Pointer
37	5416050	Dial Pointer
38	0400200	Dial Pointer Lamp, 6.3V 75mA
39	5516030	Teflon Sheet
40	5407930	Dial Glass
41	7036451	Tuning Unit
42	5269330	Meter Holder
43	7726060	Meter Circuit Board
44	4300740	Signal Meter
45	4300750	Tune Meter
46	0420040	Meter Lamp, 7V 330mA
47	0400420	FM Stereo Indicator, 7V 100mA
48	0400420	Indicator Lamp, 7V 100mA
49	5066211	Illumination Box
50	7136080	Tension Unit
51	6146670	Dial Pulley, D-44
52	5517050	Leg
53	5058510	Bottom Plate

9. PACKING LIST

Parts No.	Stock No.	Description
1	9116271	Vinyl Cover
2	9027940	Stylofoam Packing (A)
3	9027930	Stylofoam Packing (B)
4	9008480	Carton Case MODEL [Ⓐ]
	9008490	Carton Case MODEL [Ⓑ]
5	5996080	Curly Stopper

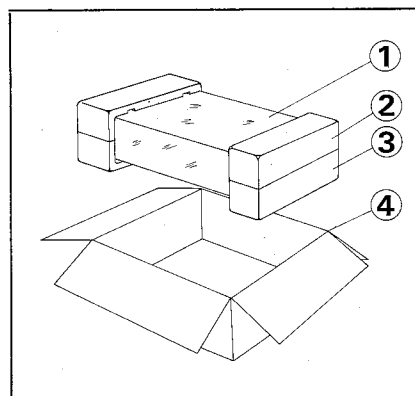

10. ACCESSORY PARTS LIST

Stock No.	Description
9209380	Operating Instructions MODEL [Ⓐ]
9209390	Operating Instructions MODEL [Ⓑ]
9237260	Schematic Diagram MODEL [Ⓐ]
9237270	Schematic Diagram MODEL [Ⓑ]

Note: In parts list above, there are two model numbers as model [Ⓐ] and [Ⓑ].
Regarding name of model [Ⓐ], [Ⓑ], please refer to "Notes" indicated on page 1.



SANSUI ELECTRIC CO., LTD.

14-1, 2-chome, Izumi, Suginamiku, Tokyo 168, Japan.
TELEPHONE: (03) 323-1111 / TELEX: 232-2076

SM053

Printed in Japan (D5200M)