



# SERVICE MANUAL

AM/FM STEREO RECEIVER

**SANSUI 8080DB/9090DB  
890DB/990DB**



*Sansui*

SANSUI ELECTRIC CO., LTD.

This service manual is designed for service engineers to repair, adjust, maintain and order the replacement parts of the 8080DB/9090DB, 890DB/990DB correctly.

When ordering the parts, use the stock number and parts name specifically referring to the Parts Location and Parts Lists.

For general usage and maintenance of the unit, please refer to the Operating Instructions attached with the unit.

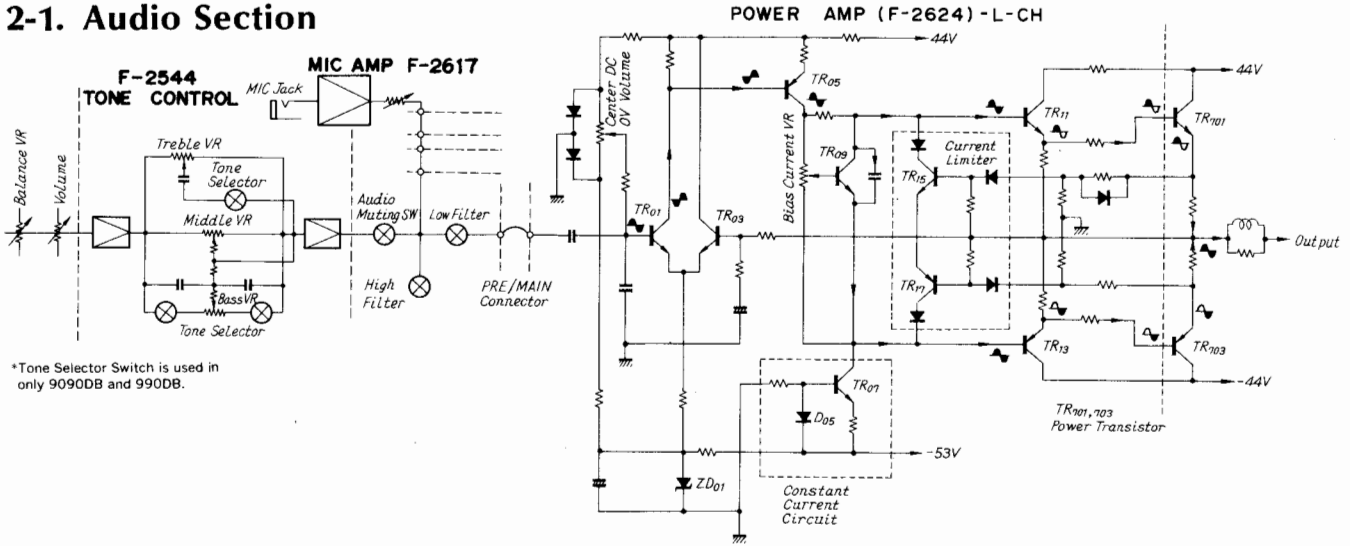
## TABLE OF CONTENTS

<u>Section</u>	<u>Title</u>	<u>Page</u>	<u>Section</u>	<u>Title</u>	<u>Page</u>
<b>1.</b>	<b>SPECIFICATIONS</b>	<b>2</b>	5-13.	F-2683 Connector Circuit Board (B)	<b>14</b>
<b>2.</b>	<b>BLOCK DIAGRAM</b>	<b>3</b>	5-14.	F-2692 Connector Circuit Board	<b>14</b>
2- 1.	Audio Section	<b>3</b>	5-15.	F-2695 LED Ass'y Circuit Board	<b>14</b>
2- 2.	Tuner Section	<b>3</b>	5-16.	F-2654 Push Switch Circuit Board	<b>15</b>
2- 3.	Dolby Mode Section	<b>4, 5</b>	5-17.	F-2655 Dolby NR Circuit Board	<b>15</b>
<b>3.</b>	<b>OPERATION OF DOLBY FM SYSTEM</b>	<b>6</b>	5-18.	F-2623 Filter Circuit Board	<b>16</b>
<b>4.</b>	<b>ADJUSTMENTS</b>	<b>6</b>	5-19.	F-2693 Push Switch Circuit Board	<b>16</b>
4- 1.	Dolby Circuit Adjustment	<b>6, 7</b>	5-20.	F-2694 Dolby Volume Circuit Board	<b>16</b>
4- 2.	Adjustment of Audio Section	<b>7, 8</b>	5-21.	F-2690 DIN Terminal Circuit Board	<b>16</b>
4- 3.	Adjustment of Tuner Section	<b>8, 9</b>	5-22.	Figures	<b>16</b>
<b>5.</b>	<b>PARTS LOCATION AND PARTS LIST</b>	<b>10</b>	<b>6.</b>	<b>OTHER PARTS</b>	<b>17</b>
5- 1.	F-2549 AM, FM Tuner Circuit Board	<b>10</b>	6- 1.	Top Side	<b>17</b>
5- 2.	F-2627 Illumination Circuit Board	<b>10</b>	6- 2.	Bottom Side	<b>17</b>
5- 3.	F-1519 Front-end Pack	<b>11</b>	6- 3.	Exploded View	<b>18</b>
5- 4.	F-2653 Equalizer Circuit Board	<b>11</b>	<b>7.</b>	<b>SCHEMATIC DIAGRAM</b>	<b>19</b>
5- 5.	F-2624 Driver Circuit Board	<b>12</b>	7- 1.	Tuner Section	
5- 6.	F-2544 Tone Control Circuit Board	<b>12</b>		(8080DB/9090DB, 890DB/990DB)	<b>19</b>
5- 7.	F-2617 Mic AMP. Circuit Board	<b>13</b>	7- 2.	Audio Section (8080DB/890DB)	<b>20</b>
5- 8.	F-2619 Power Supply Circuit Board of RF Section	<b>13</b>	7- 3.	Audio Section (9090DB/990DB)	<b>21</b>
5- 9.	F-2657 Power Relay Circuit Board	<b>13</b>	<b>8.</b>	<b>THREADING OF DIAL CORD</b>	<b>22</b>
5-10.	F-2656 Power Supply Circuit Board	<b>14</b>	8- 1.	Threading of Dial Cord	<b>22</b>
5-11.	F-2684 Connector Circuit Board (C)	<b>14</b>	8- 2.	Attachment of Dial Pointer	<b>22</b>
5-12.	F-2682 Connector Circuit Board (A)	<b>14</b>	<b>9.</b>	<b>PACKING LIST</b>	<b>back cover</b>
			<b>10.</b>	<b>ACCESSORY PARTS LIST</b>	<b>back cover</b>



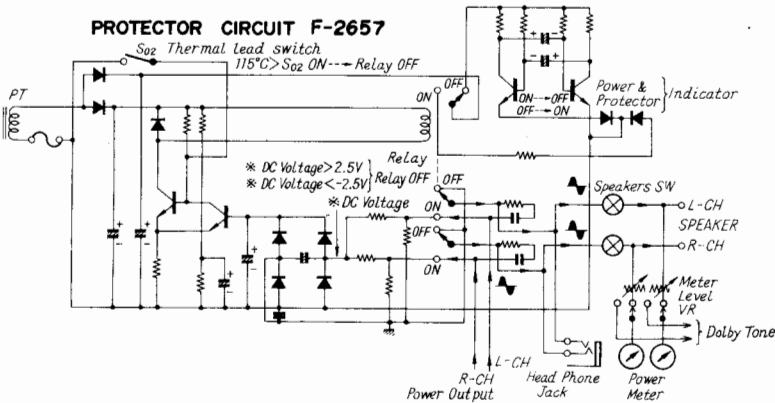
## 2. BLOCK DIAGRAM

### 2-1. Audio Section

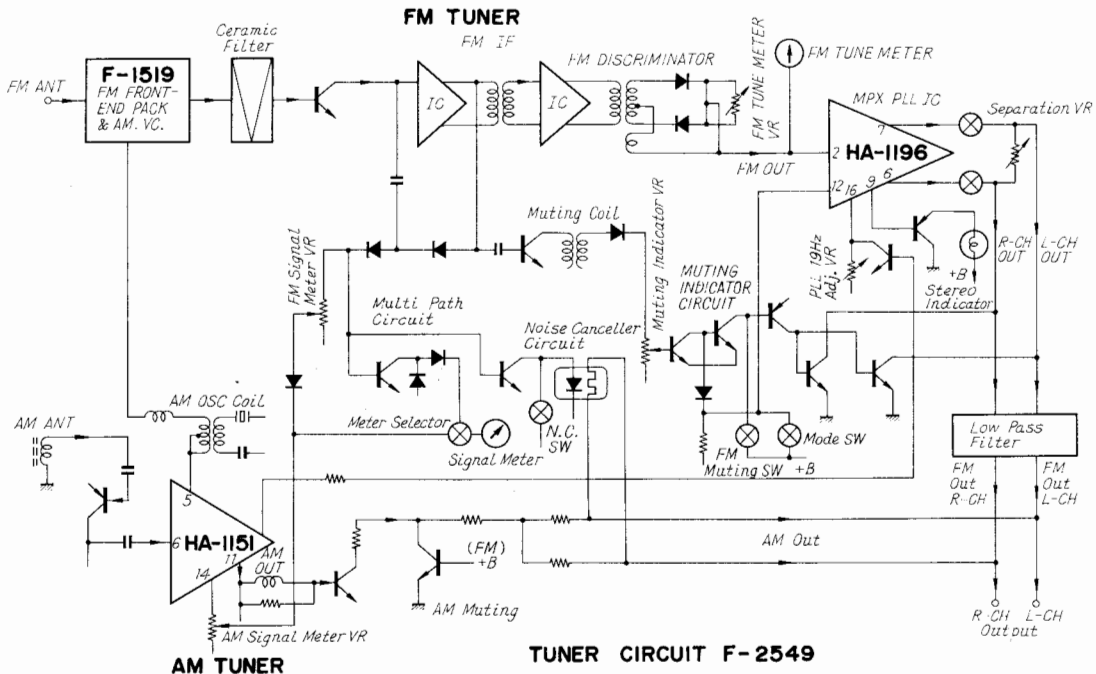


\*Tone Selector Switch is used in only 9090DB and 990DB.

### PROTECTOR CIRCUIT F-2657

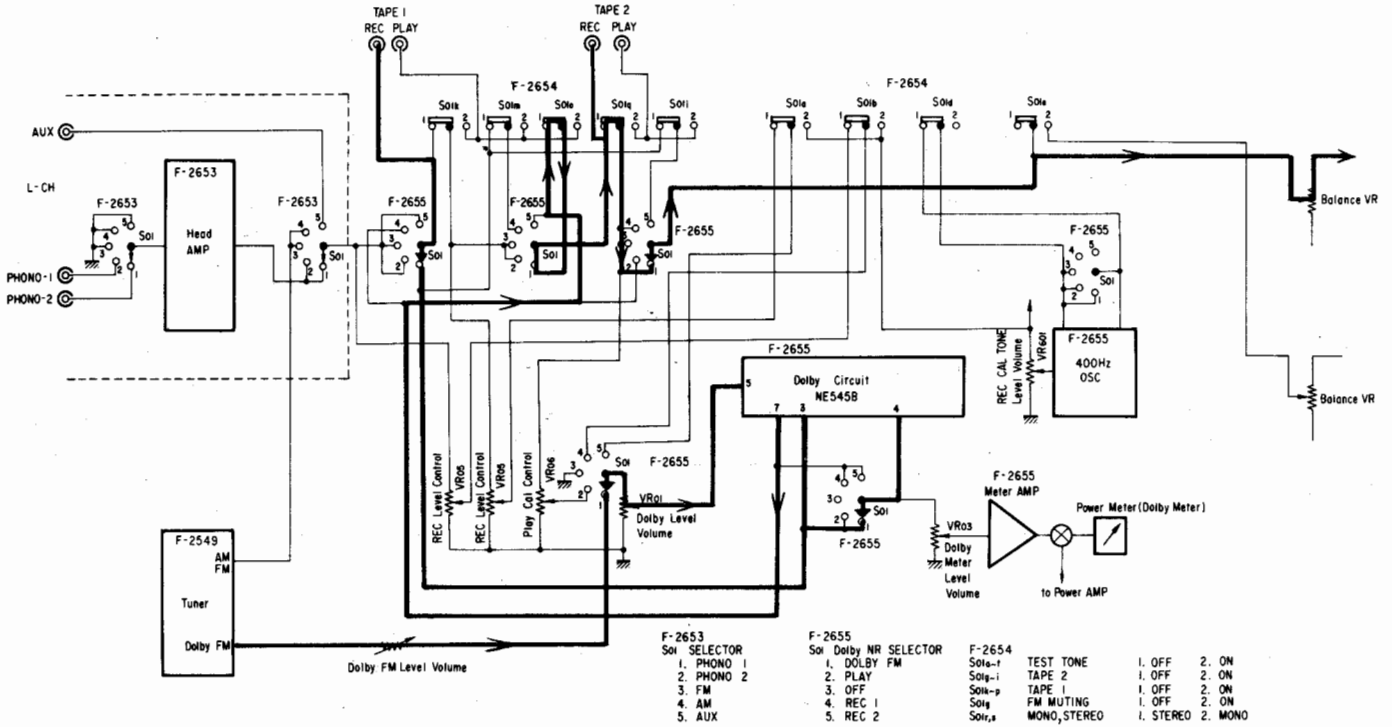


### 2-2. Tuner Section

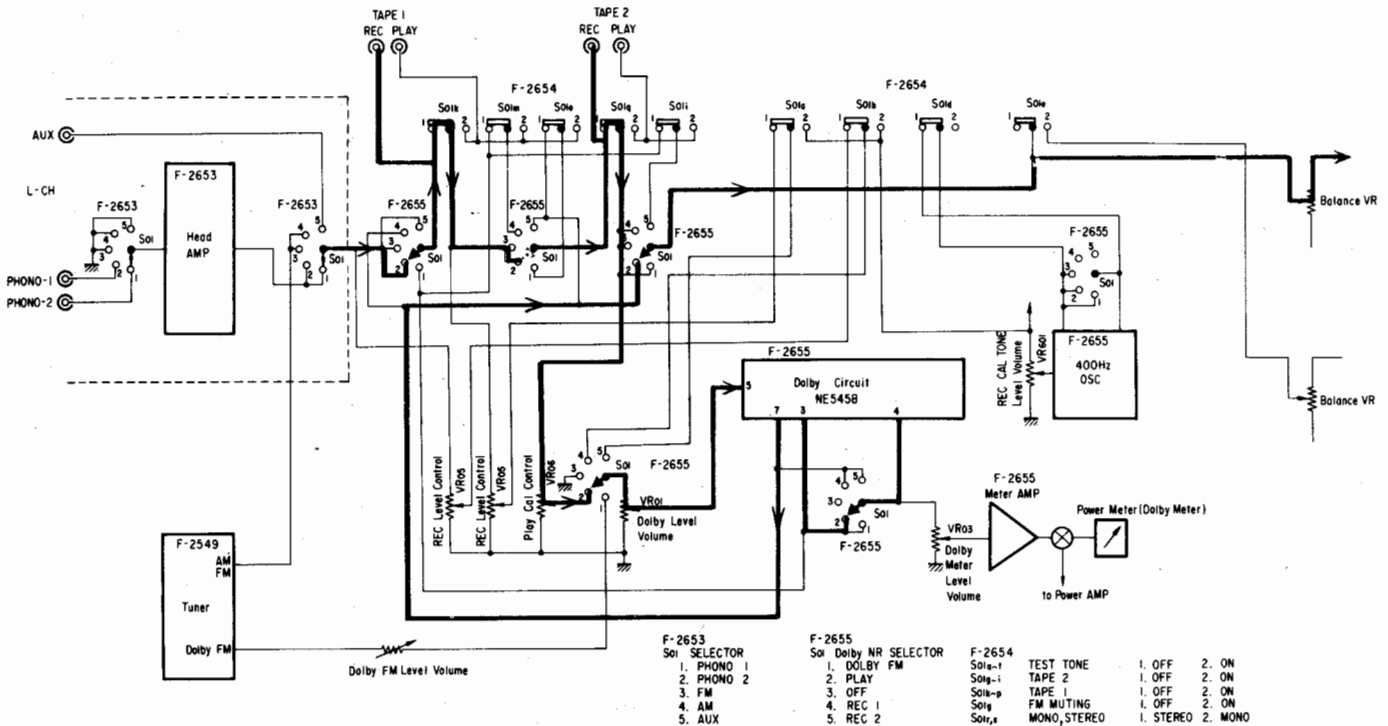


## 2-3. Dolby Mode Section

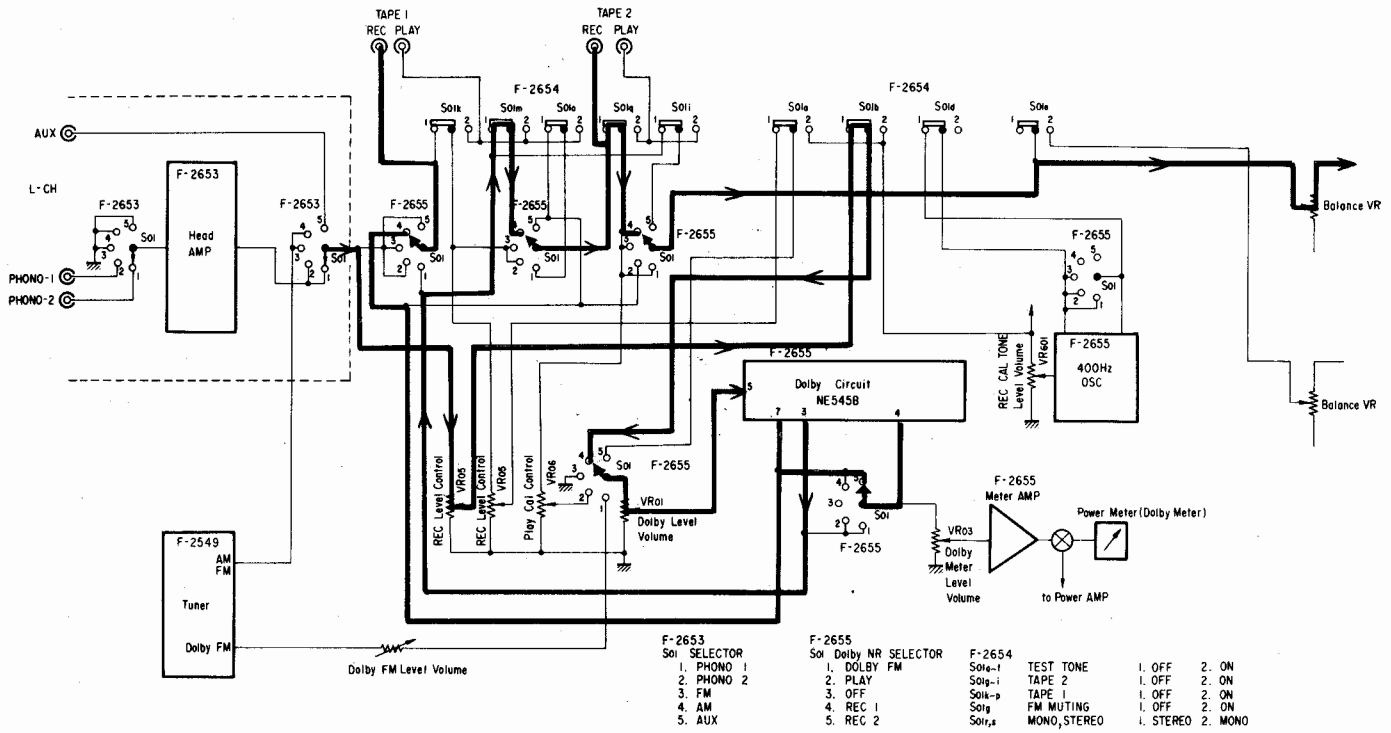
### 2-3-1. Dolby FM (Dolby NR Selector)



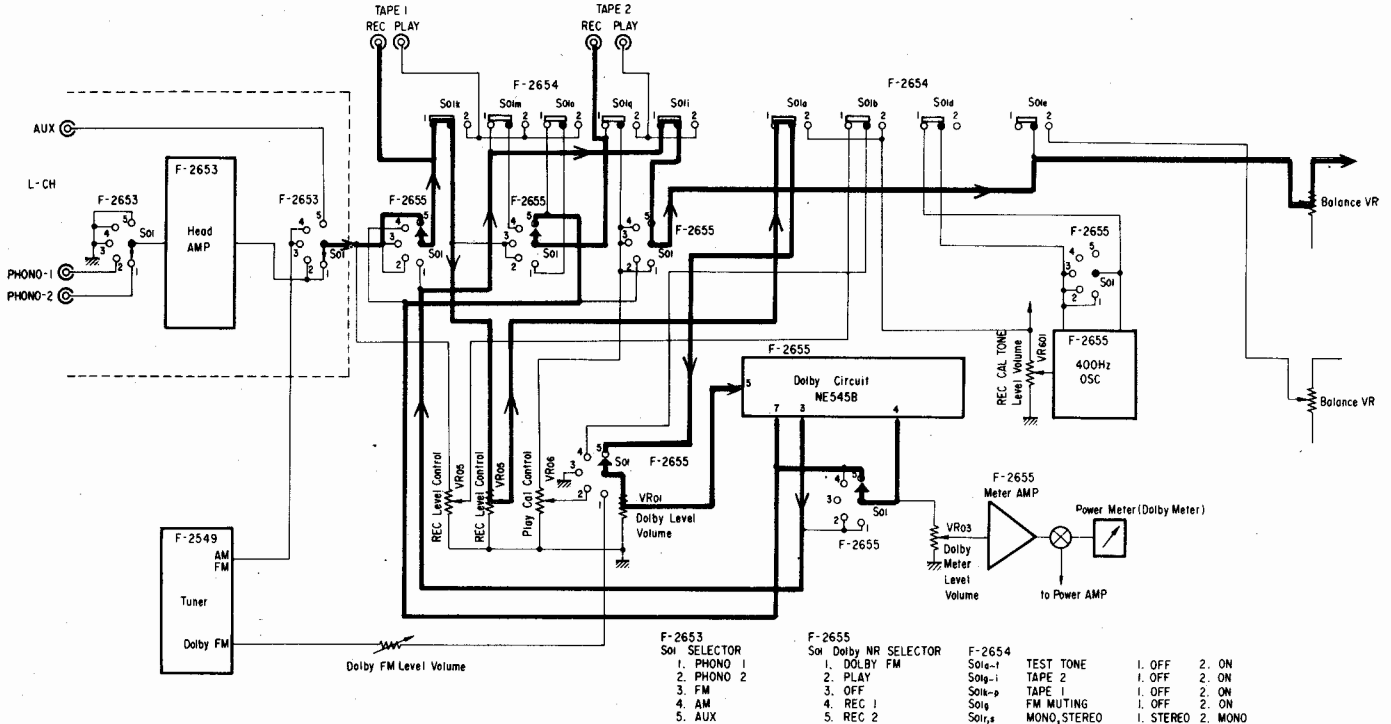
### 2-3-2. Play (Dolby NR Selector)



**2-3-3. Rec (1) (Dolby NR Selector)**



**2-3-4. Rec (2) (Dolby NR Selector)**



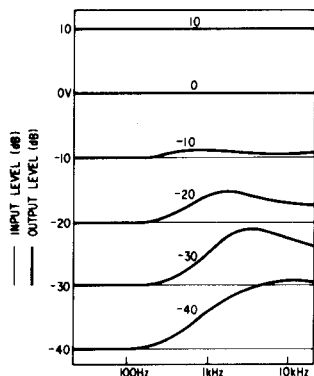
### 3. OPERATION OF DOLBY FM SYSTEM

This Dolby Noise Reduction System Type B used in this unit is not only available for encoding of the FM dolbyized signal but also useful for encoding and decoding of other signals. Therefore it is possible and effective to combine with other products such as a cassette deck without Dolby system.

#### Dolby FM System

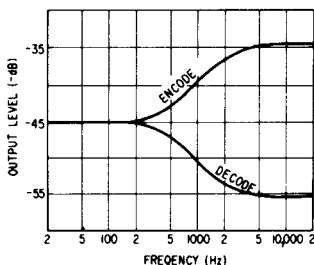
FM broadcasting system is originally able to produce a very high quality audio performance; however, FM stereophonic broadcasting system incurs a 20dB Signal-Noise ratio decrease. When Dolby B Type Noise Reduction system is used for a FM stereo, Signal-Noise ratio (S/N) is conspicuously improved and this ratio is at about 10dB.

Fig. 3-1



Whole range output Frequency Response characteristics against input level.

Fig. 3-2



Low level Frequency Response characteristics of encode and decode processors.

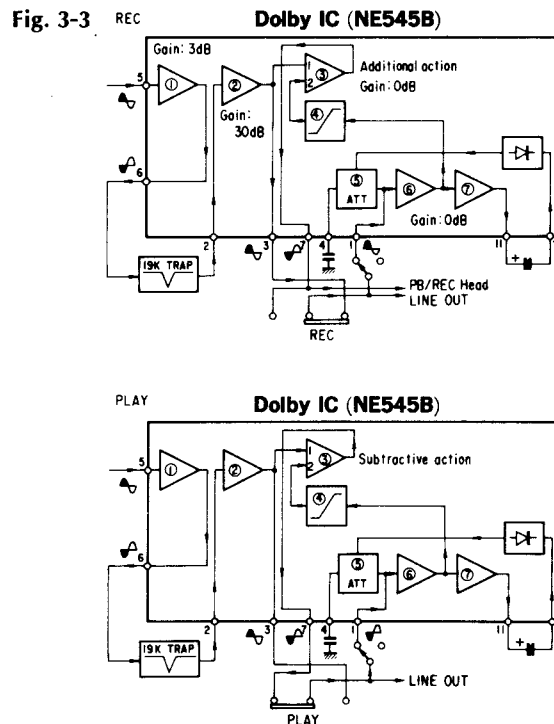
#### Principles

The S/N of the FM becomes worse when the frequency is high and the level is low. Because of this reason, the middle and high range of the low level signal is expanded by a FM station. Then the signal will be compressed proportionally along the expanded level by a receiving side. (See Fig. 1, 2)

This unit employs a IC NE545B for a main Dolby circuit. The Operating diagram is shown in the Fig. 3-3.

#### Complementary items

1. When Dolby FM system is being used, the de-emphasis of FM-out is 25μs.
2. The input level of Dolby FM is at 50% modulation and ±37.5kHz.
3. This unit has an own 400Hz Oscillator for Dolby Tone in order to adjust itself to the Dolby level.



## 4. ADJUSTMENTS

### 4-1. Dolby Circuit Adjustment

#### 4-1-1. Input Level Adjustment of Dolby IC (NE545B) (See Fig. 4-2)

- Note:
- |                              |                             |                                    |
|------------------------------|-----------------------------|------------------------------------|
| 1. Speaker Selector.....A    | 4. Selector.....AUX         | 7. Dolby Selector Switch.....REC 1 |
| 2. Master Volume.....Minimam | 5. Accessory Switch.....OFF |                                    |
| 3. Balance Volume.....Center | 6. REC Level Volume.....MAX |                                    |

STEP	SUBJECT	FEED SIGNAL		MEASURE OUTPUT	ADJUST	ADJUST FOR
		FROM	TO			
1.	L-CH	400Hz 80mV Audio OSC.	AUX Terminal	REC Terminal TAPE I VTVM	VR01 F-2655	Output 270mV
2.	R-CH	Same as above	AUX Terminal	REC Terminal TAPE I VTVM	VR02 F-2655	Same as above

### 4-1-2. Calibration Tone Volume & Dolby Meter Volume Adjustment (See Fig. 4-1, 4-2)

- Note:**
1. Speaker Selector .....A
  2. Master Volume .....Minimum
  3. Balance Volume .....Center
  4. Accessory Switch .....OFF
  5. Dolby Selector Switch .....REC 1

**Step**

1. Turn on the Dolby REC CAL TONE Switch.
2. Connect VTVM to the front TAPE I REC terminal.
3. Adjust VR601 on the circuit board, F-2655 to obtain 270mV on indication of VTVM.
4. Adjust both VR03 (L-CH) and VR04 (R-CH) on the circuit board, F-2655 so that indicator of power meter will be center of Dolby mark.

Fig. 4-1

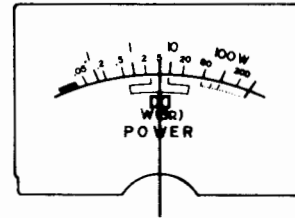
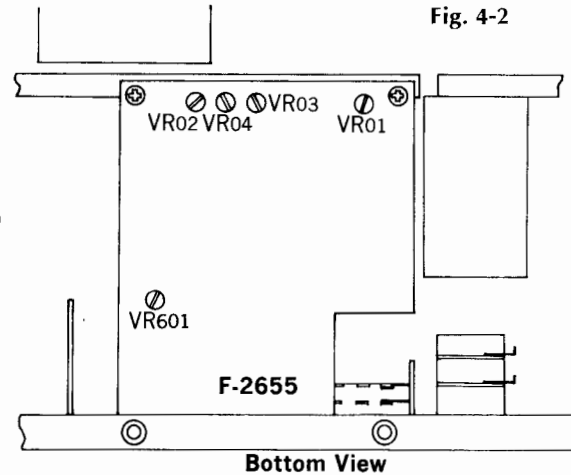


Fig. 4-2

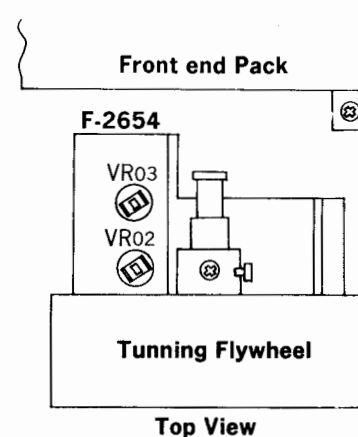


### 4-1-3. Dolby FM Volume Adjustment (See Fig. 4-3)

- Note:**
1. Selector .....FM Auto
  2. Dolby Selector .....Dolby FM
  3. REC CAL. TONE Switch .....OFF
  4. Master Volume .....Min.

SUBJECT	FEED SIGNAL		MEASURE OUTPUT	ADJUST	ADJUST FOR
	FROM	TO			
L-CH	98MHz ANT Input 60dB FM SSG Pilot 19kHz (10% MOD) L-CH 1kHz (25% MOD) R-CH (0% MOD)	FM ANT Terminal 300Ω	REC Terminal TAPE I L-CH VTVM	VR03 F-2654	Output Level 270mV
R-CH	98MHz ANT Input 60dB FM SSG Pilot 19kHz (10% MOD) R-CH 1kHz (25% MOD) L-CH (0% MOD)	Same as above	REC Terminal TAPE I R-CH VTVM	VR02 F-2654	Same as above

Fig. 4-3



## 4-2. Adjustment of Audio Section

### 4-2-1. Power Meter Adjustment (See Fig. 4-4)

- Note:**
1. Input .....AUX
  2. Speaker load .....8Ω
  3. Input Signal .....Sine Wave (1kHz)
  4. Master Volume .....Maximum
  5. For adjustment, run the unit for more than 4 minutes after the power is switched ON.

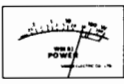
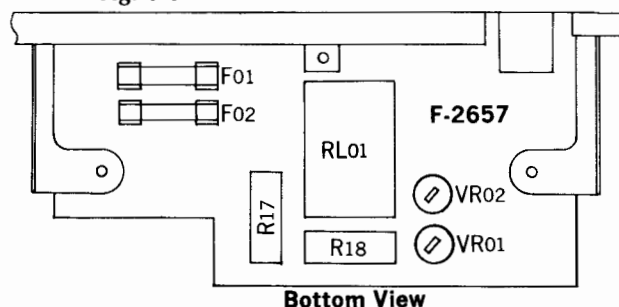
STEP	MEASURE OUTPUT	LEVEL OUTPUT	ADJUST	ADJUST FOR
L-CH	Speaker Terminal L-CH AC Volt Meter	20V (50W)	VR01 F-2657	Meter Position 50W
R-CH	Speaker Terminal R-CH AC Volt Meter	Same as above	VR02 F-2657	

Fig. 4-4

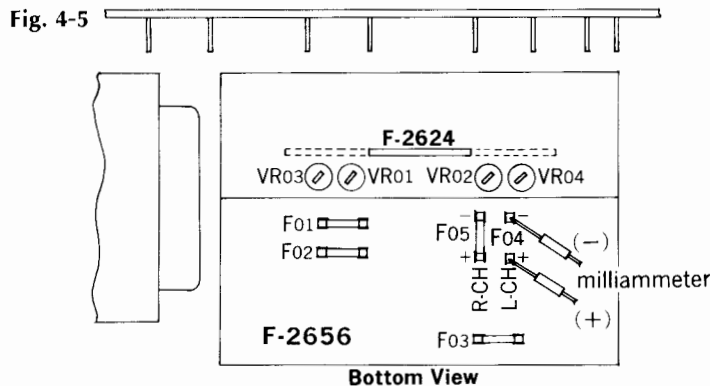




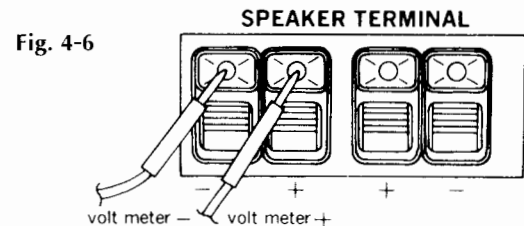
## 4-2-2. Driver Circuit Board Adjustment (See Fig 4-5, 4-6 page 8)

- Note:** 1. Master Volume.....Minimum  
 2. Before adjustment, run the unit for more than 4 minutes, then check and readjust necessary.

STEP	SUBJECT	EQUIPMENT	MEASURE OUTPUT	ADJUST	ADJUST FOR	CONDITION
1.	DC 0V L-CH	DC volt Meter	Speaker Terminal L-CH	VR01 F-2624	0V $\pm$ 10mV	<ul style="list-style-type: none"> <li>Step down meter range accordingly.</li> <li>Change leads polarity if meter swings backward.</li> </ul>
2.	DC 0V R-CH	Same as above	Speaker Terminal R-CH	VR02 F-2624	Same as above	Same as above
3.	Bias Current L-CH	DC Milliammeter	F04 F-2656	VR03 F-2624	30mA $\pm$ 1mA	Step down meter range accordingly
4.	Bias Current R-CH	Same as above	F05 F-2656	VR04 F-2624	Same as above	Same as above



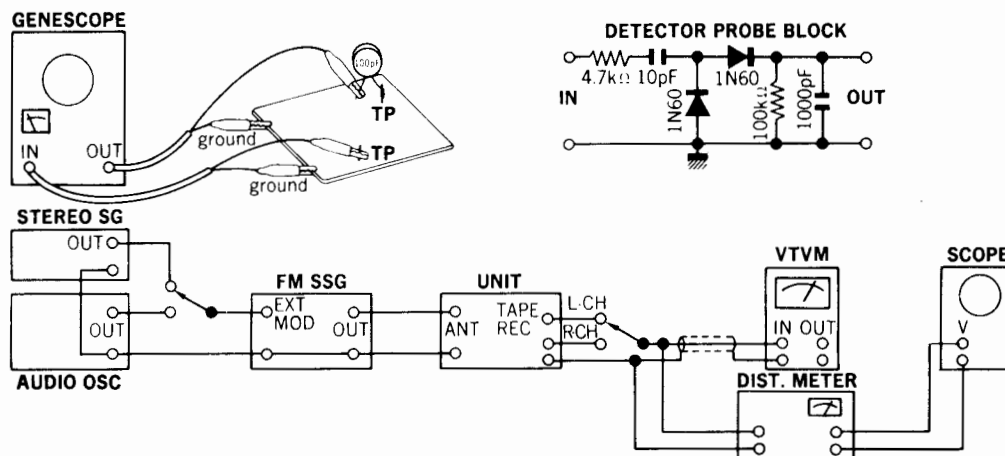
**Note:** In adjustment above, there are two model numbers as model **A** and **B**. Regarding name of model **A** and **B**, please refer to "Note" indicated on page 1.



## 4-3. Adjustment of Tuner Section

### 4-3-1. FM Adjustment & Alignment

- Note:** 1. Selector.....FM AUTO      2. FM MUTING Switch.....OFF  
 Connection.....Connect the output of genescope to TP through 100pF ceramic capacitor  
 Output level of genescope.....After attenuator  
 3. Sweep width.....1.5~2cm/150kHz  
 Frequency band.....9.5~11.5MHz



1) FM IF Adjustment & Tracking (See Fig. 4-7, 4-8, 4-9 on Page 9)

STEP	SUBJECT	FEED SIGNAL		MEASURE OUTPUT	ADJUST	ADJUST FOR	CONDITION
		FROM	TO				
1.	IF coil	Output 90dB Genescope	TP01 FM, AM Pack F-1519	Terminal 01 of F-2549. Use Detector Probe	L05 F-1519	Max. IF waveform	
		Output 50dB Genescope	Same as above	TP01 F-2549	T01 F-2549	Same as above	
2.	Muting Coil	Output 50dB Genescope	Same as above	TP04 F-2549	T04 F-2549	Same as above	
3.	Discriminator Coil	Output 50dB Genescope	Same as above	TP03 F-2549	T02 T03 F-2549	Max. linearity of S Curve	
4.	90MHz Dial Calibration	90MHz ANT Input 60dB 400Hz (100% MOD) FM SSG	ANT Terminal 300Ω	REC OUT L or R-CH VTVM & Scope	L06 F-1519	Max. Output	
	106MHz Dial Calibration	106MHz ANT Input 60dB 400Hz (100% MOD) FM SSG	Same as above	Same as above	TC04 F-1519	Same as above	
5.	90MHz RF Adj.	90MHz ANT Input 60dB 400Hz (100% MOD) FM SSG	Same as above	Same as above	L01, L02, L03 F-1519	Same as above	
	106MHz RF Adj.	106MHz ANT Input 60dB 400Hz (100% MOD) FM SSG	Same as above	Same as above	TC01 TC02 TC03 F-1519	Same as above	
6.	Signal Meter Volume	98MHz ANT Input 100dB 400Hz (100% MOD) FM SSG	Same as above	Signal Meter	VR02 F-2549	4.7 on meter	
7.	Distortion	98MHz ANT Input 60dB 400Hz (100% MOD) FM SSG	Same as above	REC OUT L or R-CH Dist meter & Scope	T02 T03 T01 F-2549	Max. Output Min. Distortion	T01.. Slightly adjust
8.	Tune Meter Volume	98MHz ANT Input 60dB 400Hz (100% MOD) FM SSG	Same as above	Tune meter	VR01 F-2549	Center on meter	

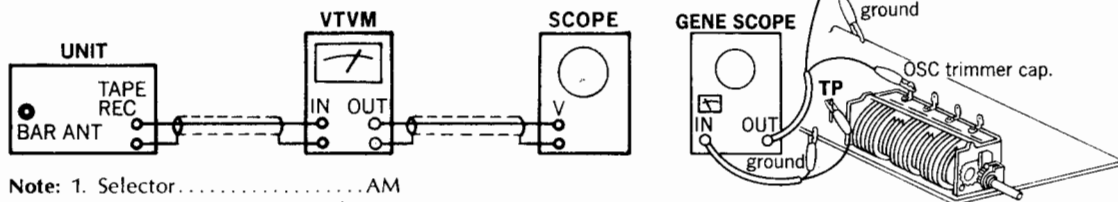
Abbreviations

<b>Equipment</b>	Distortion Meter .....	Dist. Meter
AM FM Generator Oscilloscope .....	Genescope	
AM Standard Signal Generator .....	AM SSG	
FM Standard Signal Generator .....	FM SSG	
FM Stereo Generator .....	Stereo SG	
Oscilloscope .....	Scope	
Audio Oscillator .....	Audio Osc.	
<b>Others</b>	Clockwise .....	CW.
	Counterclockwise .....	CCW.
	Antenna .....	ANT.
	Modulation .....	MOD.

**2) MPX Adjustment (See Fig. 4-8, 4-9 on page 9)**

STEP	SUBJECT	FEED SIGNAL		MEASURE OUTPUT	ADJUST	ADJUST FOR	CONDITION
		FROM	TO				
1.	PLL VCO Adj.	98MHz ANT Input 60dB FM SSG Pilot 19kHz (10% MOD) L-CH 1kHz (45% MOD) R-CH (0% MOD) STEREO SG	ANT Terminal 300Ω	Stereo Indicator	VR04 F-2549	Light Indicator	Adjust the VR within center of lighting level.
	PLL VCO Adj. In case of using Freq Counter		Make short between TP03 of F-2549 and chassis	TP02 F-2549 Use Freq. Counter	VR04 F-2549	76kHz (±200Hz)	
2.	Separation	98MHz ANT Input 60dB FM SSG Pilot 19kHz (10% MOD) L-CH (0% MOD) R-CH 1kHz (45% MOD) STEREO SG	ANT Terminal 300Ω	REC OUT L-CH VTVM & Scope	VR05 F-2549	Min. Output - 35dB	
3.	Distortion	Same as above	Same as above	REC OUT L-CH Dist. meter & Scope	L05 1 Side 2 Side AM, FM Pack F-1519	Min. Distortion	If less than 0.3%, adjust L05 slightly.
4.	Separation	98MHz ANT Input 60dB FM SSG Pilot 19kHz (10% MOD) L-CH 1kHz (45% MOD) R-CH (0% MOD) STEREO SG	Same as above	REC OUT R-CH VTVM & Scope	VR05 F-2549	Min. Output - 30dB	
5.	Muting level & Indicator level	98MHz ANT Input 23dB FM SSG Pilot 19kHz(10%MOD) L-CH 1kHz(45% MOD) R-CH (0% MOD) STEREO SG	Same as above	Stereo Indicator	VR03 F-2549	Muting level 23dB Indicator lighting level 23dB	

**4-3-2. AM IF Adjustment & Tracking (See Fig. 4-8, 4-9 on page 9)**




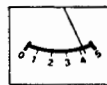
STEP	SUBJECT	FEED SIGNAL		MEASURE OUTPUT	ADJUST	ADJUST FOR	CONDITION
		FROM	TO				
1.	IF Coil	Genescope Output 70dB	TC05 FM, AM Pack F-1519	TP06 F-2549	CF04 F-2549	Max. Output	
2.	600kHz Dial Calibration	600kHz ANT Input 60dB 400Hz (MOD 30%) AM SSG	AM ANT Terminal	REC OCT L or R-CH VTVM & Scope	T05 F-2549	Same as above	
	1400kHz Dial Calibration	1400kHz ANT Input 60dB 400Hz (MOD 30%) AM SSG	Same as above	Same as above	TC05 FM, AM Pack F-1519	Same as above	
3.	600kHz RF Adj.	600kHz ANT Input 50dB 400Hz (MOD 30%) AM SSG	Same as above	Same as above	Bar Antenna T702	Same as above	
	1400kHz RF Adj.	1400kHz ANT Input 50dB 400Hz (MOD 30%) AM SSG	Same as above	Same as above	TC06 FM, AM Pack F-1519	Same as above	
4.	Signal Meter	1000kHz ANT Input 80dB	Same as above	Signal Meter	VR06 F-2549	4.3 on meter	

Fig. 4-7

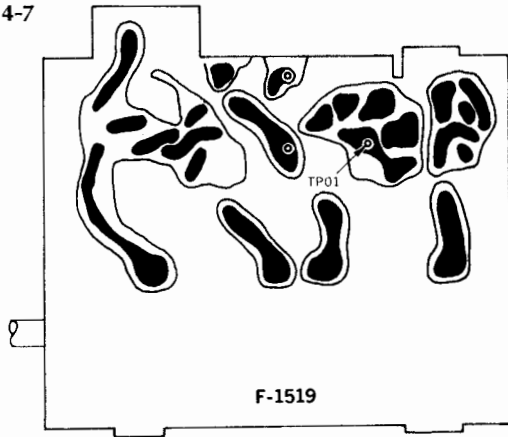


Fig. 4-8

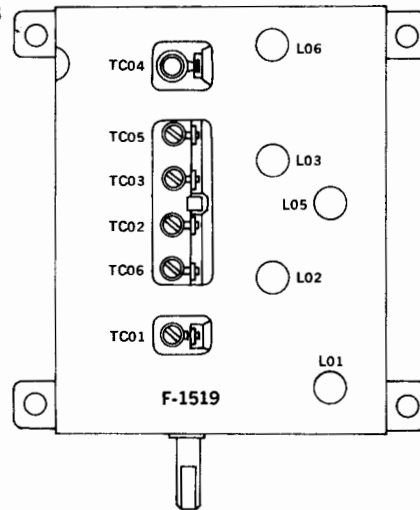
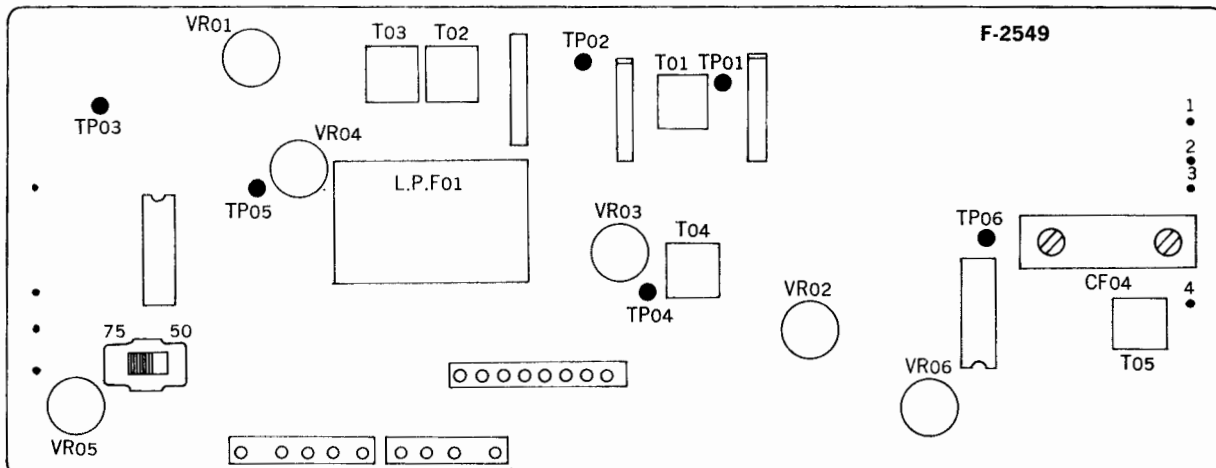


Fig. 4-9



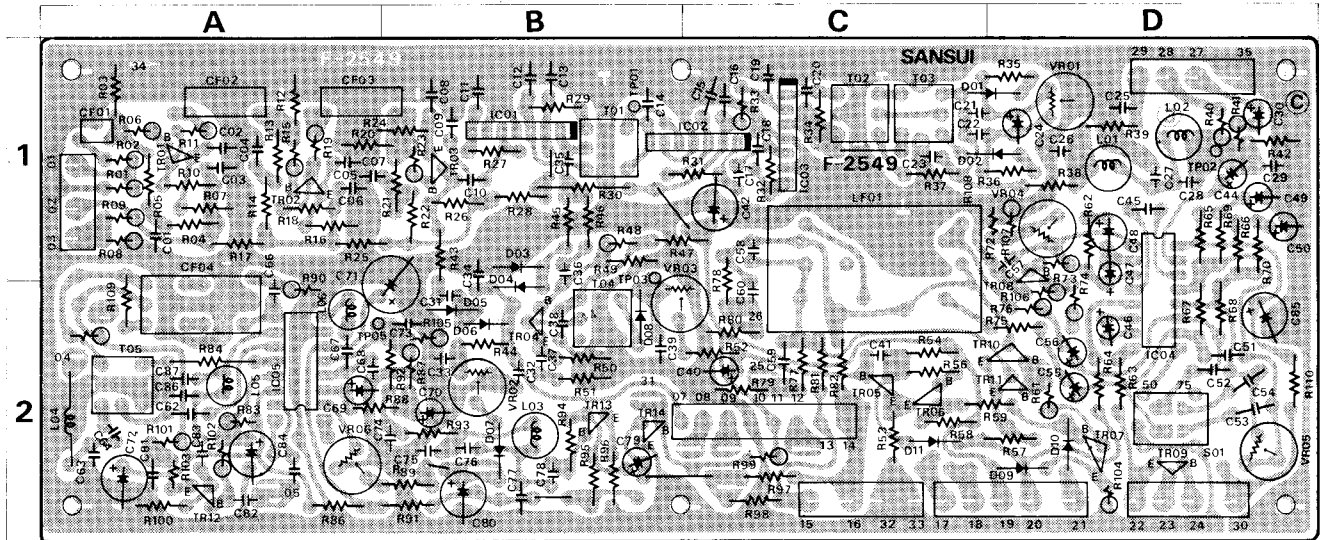
# 5. PARTS LOCATION AND PARTS LIST

## 5-1. F-2549 AM, FM Tuner Circuit Board

(Stock No. 7521401 MODEL 8080DB/8090DB) (Stock No. 7521391 MODEL 9090DB/990DB)

Since some of capacitors and resistors are omitted from parts lists in this Service Manual, refer to the common parts list for capacitors & resistors which was appended previously to each Service Manual.

Conductor Side



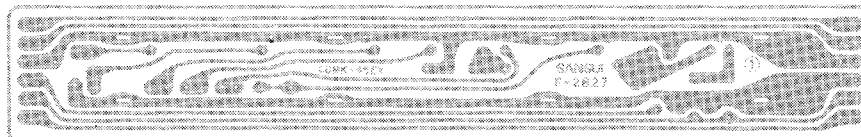
### Parts List

Parts No.	Stock No.	Description	Position	Parts No.	Stock No.	Description	Position	Parts No.	Stock No.	Description	Position
TR01	0306113	3SC738 (D)	1A	D08	0310330.1	1N60	2B	T01	4235860		1B
TR02	0306113	2SC738 (D)	1A	D09	0311160	1S2473D	2D	T02	4235750		1C
TR03	0306112.3	2SC738 (C, D)	1B		0311180	1S1588		T03	4235760	FM IF Coil	1C
TR04	0306112.3	2SC738 (C, D)	2B	D10	0311160	1S2473D	2D	T04	4235940		2B
TR05	0305731.2	2SC711 (E, F)	2C		0311180	1S1588		T05	4220550		2A
TR06	0305731.2	2SC711 (E, F)	2C	D11	0311160	1S2473D	2C	CF01	0910150		1A
TR07	0300281.2	2SA628 (D, E)	2D		0311180	1S1588		CF02	0910330	Ceramic Filter	1A
TR08	0305731.2	2SC711 (E, F)	1D	C26	0620181	180pF	1D	CF03	0910330		1A
TR09	0300220.1	2SA662 (O, Y)	2D	C27	0620331	330pF	1D	CF04	0910310		2A
TR10, 11	0306390.1	2SC1636-1.2	2D	C28	0620101	100pF	50V P.C.	LF01	0910360	Low Pass Filter	1, 2C
TR12	0300281	2SA628 (D)	2A	C29	0620151	150pF	1D	VR01	1035150	22kΩ (B)	1D
TR13	0306091	2SC1312R (G)	2B	C44	0573688	0.68μF	35V T.C.	VR02	1035170	47kΩ (B)	2B
TR14	0306390.1	2SC1636-1.2	2B	C53, 54	0620511	510pF	50V P.C.	VR03	1035170	47kΩ (B)	2B, C
IC01	0360120	μPC555H	2B	C57	0629005	360pF	50V P.C.	VR04	1034250	4.7kΩ (B)	1D
IC02	0360120	μPC555H	1B, C	C63	0669400	15pF	2A	VR05	1035210	220kΩ (B)	2D
IC03	0360120	μPC555H	1C	C64	0620361	360pF	50V C.C.	VR06	1035110	4.7kΩ (B)	1A
IC04	0360320	HA1196	1, 2D	C86	0661150	15pF	2A	S01	1110270	Slide Switch	
IC05	0360150	HA1151	2A	C87	0661150	15pF	2A	0990010		Ceramic Filter	
D01	0311060	1N60-P	1C, D	L01	4900250		1D	2410570		5P Pin Ass'y Type D	
D02	0311060	1N60-P	1C, D	L02	4900240	Inductor	1D	2410580		3P Pin Ass'y Type D	
D03	0310330.1	1N60	1B	L03	4900220		2B	2410590		4P Pin Ass'y Type D	
D04	0310330.1	1N60	2B	L04	4290011		2A				
D05	0310330.1	1N60	2B	L05	4900110		2A				
D06	0310330.1	1N60	2B	L06	4900110	Inductor	2A				
D07	0310330.1	1N60	2B								

## 5-2. F-2627 Illumination Circuit Board (Stock No. 7594211 MODEL 8080DB/890DB)

(Stock No. 7594301 MODEL 9090DB/990DB)

Conductor Side

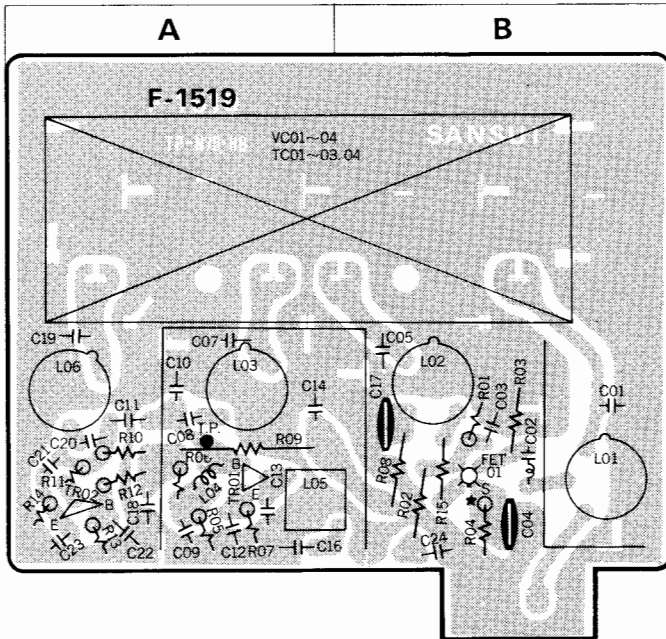


### Parts List

Parts No.	Stock No.	Description
R01	0191180	18Ω 1/4W Fuse R
PL01-04	0420040	7V 320MA Pilot Lamp

### 5-3. F-1519 Front-end Pack (Stock No. 7510631)

Conductor Side



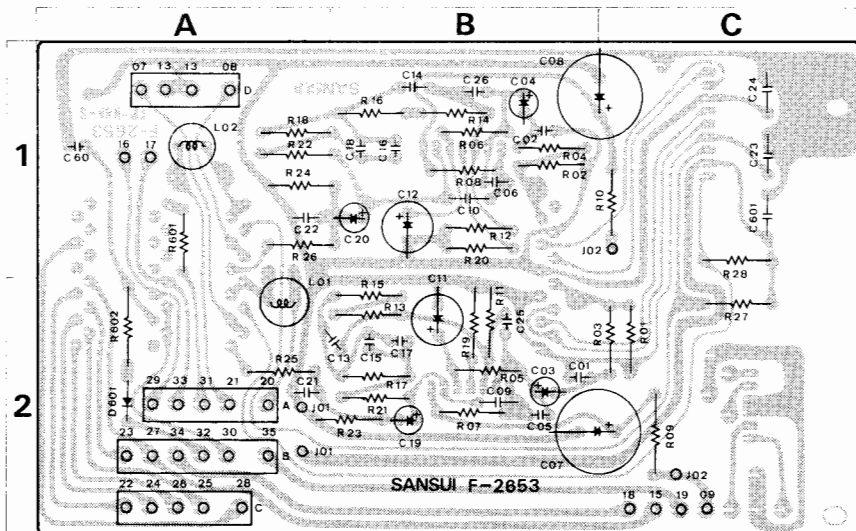
Parts No.	Stock No.	Description	Position
C01	0669342	5.6pF	
C02	0657102	1000pF	B
C03	0657223	0.022pF	50V C.C. B
C04	0659015	2200pF	B
C05	0669345	10pF	B
C06	0679023	0.39pF	500V Gimmick B
Capacitor			
C07	0669345	10pF	A
C08	0669210	10pF	A
C09	0657102	1000pF	A
C10	0661220	22pF	A
C11	0669202	2.2pF	A
C12	0657223	0.022pF	A
C13	0660121	120pF	50V C.C. A
C14	0657223	0.022pF	A
C16	0660331	330pF	A
C17	0659015	2200pF	B
C18	0657223	0.022pF	A
C19	0669375	15pF	A
C20	0657102	1000pF	A
C21	0669209	8.2pF	A
C22	0657223	0.022pF	50V C.C. A
C23	0661220	22pF	A
C24	0657223	0.022pF	B
R01	0106105	1MΩ	1/4W C.R.(E.L.R.) B
R02	0113104	100kΩ	B
R03	0113104	100kΩ	1/4W S.R. B
R04	0106101	100Ω	(3SK41(1)K) B
R05	0106680	68Ω	(3SK41(1)L) B
R06	0106682	6.8kΩ	1/4W C.R.(E.L.R.) A
R07	0106123	12kΩ	A
R08	0106392	3.9kΩ	A
R09	0113271	270Ω	1/4W S.R. A
R10	0106392	3.9kΩ	A
R11	0106121	120Ω	A
R12	0106682	6.8kΩ	1/4W C.R. A
R13	0106222	2.2kΩ	A
R14	0106182	1.8kΩ	A
R15	0113680	68Ω	1/4W S.R. B
2260010		Test Pin	

#### Parts List

Parts No.	Stock No.	Description	Position	Parts No.	Stock No.	Description	Position
TR01	0305800.1	2SC1047 (A, B)	Transistor	L04	4290110	Choke Coil	A
TR02	0305790.1	2SC930 (C, D)		A			
FET01	0370131.2	3SK41 (K, L)		FET	L05	4235910	IF Coil
L01	4200640	Antenna Coil	B	L06	4220430	OSC Coil	A
L02	4210330	RF Coil (1)	B	VC01-04	1220130	FM, AM Variable Capacitor	A, B
L03	4210220	RF Coil (2)	A	TC01-03			A, B
				TC04	1230090	FM OSC Trimmer	A, B

### 5-4. F-2653 Equalizer Circuit Board (Stock No. 7550971 MODEL 8080DB/890DB) (Stock No. 7551001 MODEL 9090DB/990DB)

Conductor Side

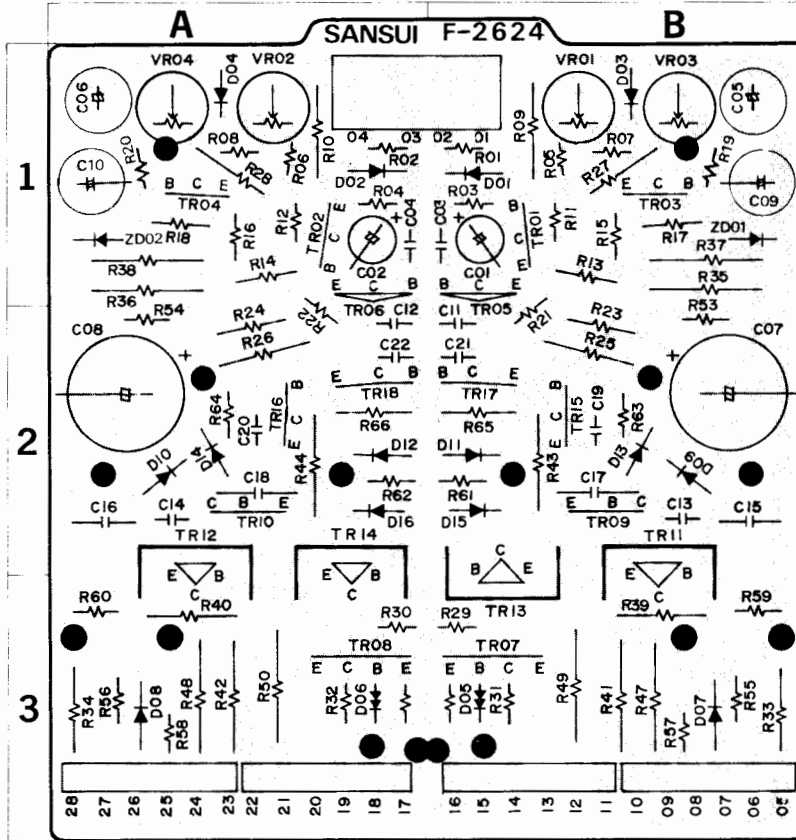


#### Parts List

Parts No.	Stock No.	Description	Position
IC01.02	0360190	BA312 IC	
D601	0311160	1S24730D	Diode 2A
	0311180	1S1588	
C03.04	0573339	3.3pF 35V T.C.	2B.1B
C13.14	0625472	4700pF	2B.1B
C15.16	0625102	1000pF 50V P.C.	2B.1B
C17.18	0620361	360pF	2B.1B
R13.14	0231564	560kΩ	1/2W M.R. 2B.1B
R17.18	0231563	56kΩ	
L01.02	4900090	Inductor	2A.1A
S01	1104350	Rotary Switch	
	2410570	5P Pin Ass'y Type D	
	2410590	4P Pin Ass'y Type D	
	2410600	6P Pin Ass'y Type D	

### 5-5. F-2624 Driver Circuit Board (Stock No. 7571431 MODEL 8080DB/890DB) (Stock No. 7571461 MODEL 9090DB/990DB)

Conductor Side

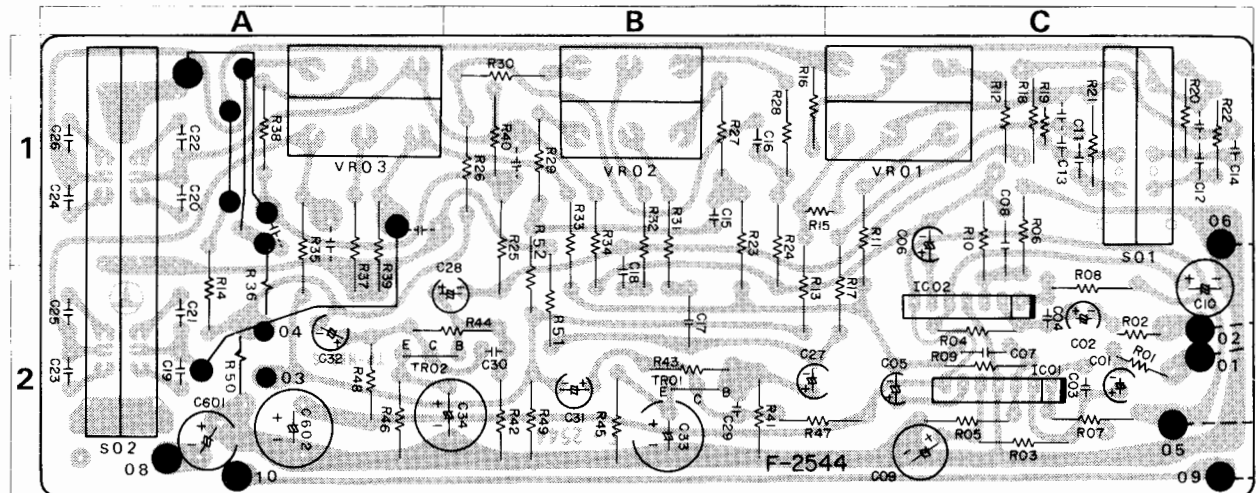


Parts List

Parts No.	Stock No.	Description	Position
TR01	0306290, 1	2SC1400 (E, U)	1B
TR03	0306290, 1	2SC1400 (E, U)	1B
TR05, 06	0300791, 2	2SA899 (B, V)	1B, 1A
TR07, 08	0304401, 2	2SC1904 (B, V)	3B, 3A
TR09, 10	0305871, 2	2SC984 (B, C)	2B, 2A
TR15, 16	0305951, 2	2SC945 (Q, P)	2B, 2A
TR17, 18	0300510, 1	2SA733 (P, Q)	2B, 2A
D01, 02	0311160	1S2473D	1B, 1A
D03, 04	0311180	1S1588	1B, 1A
D05, 06	0340120	VD1212	3B, 3A
D07, 08	0311160	1S2473D	3B, 3A
D09, 10	0311180	1S1588	2B, 2A
D11, 12	0311160	1S2473D	2B, 2A
D13, 14	0311180	1S1588	2B, 2A
D15, 16	0311160	1S2473D	2B, 2A
ZD01, 02	0316070	EQA01-24R Zener Diode	1B, 1A
R33, 34	0191181	180Ω	3B, 3A
R35, 36	0191479	4.7Ω	1B, 1A
R37, 38	0210392	3.9kΩ	1B, 1A
R39, 40	0192100	10Ω	3B, 3A
R41, 42	0192151	150Ω	3B, 3A
R43, 44	0192151	150Ω	2B, 2A
R47, 48	0192479	4.7Ω	3B, 3A
R49, 50	0192479	4.7Ω	3B, 3A
VR01, 02	1035350	4.7kΩ (B)	1B, 1A
VR03, 04	1035310	1kΩ (B)	1B, 1A
	2410930	4P Pin Ass'y Type E	
	2420520	6P Connector Ass'y Type A	
<b>MODEL 8080DB/890DB Only</b>			
TR11, 12	0308431, 2	2SD381 M, L	2B, 1A
TR13, 14	0303260, 1	2S8536 N, M	2B, 1A
<b>MODEL 9090DB/990DB Only</b>			
TR11, 12	0308531, 2	2SD381 (2) M, L	2B, 1A
TR13, 14	0303371, 2	2S8536 (2) M, L	2B, 1A

### 5-6. F-2544 Tone Control Circuit Board (Stock No. 7561511 MODEL 8080DB/890DB) (Stock No. 7561551 MODEL 9090DB/990DB)

Conductor Side

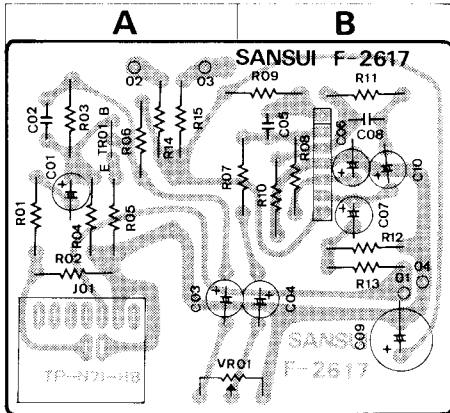


Parts List

Parts No.	Stock No.	Description	Position	Parts No.	Stock No.	Description	Position
TR01, 02	0306070-2	2SC1313 (F, G, H)	2C, 2A	VR01	1010930, 1	100kΩ (B)	1C
IC01, 02	0360190	BA312 IC	2C	VR02	1010930, 1	100kΩ (B)	1B
C01, 02	0573109	1.0μF	2C	<b>MODEL 9090DB/990DB Only</b>			
C27, 28	0573229	2.2μF	2B	S01	1171240	Lever Switch	1C
				S02	1171220	Lever Switch	1, 2A

5-7. F2617 Mic AMP. Circuit Board (Stock No. 7610111 MODEL 8080DB/890DB)  
(Stock No. 7610121 MODEL 9090DB/990DB)

Conductor Side

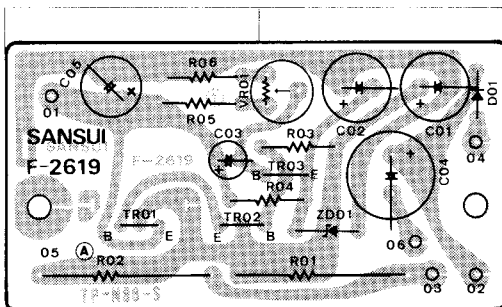


Parts List

Parts No.	Stock No.	Description	Position
TR01	0306070-2	2SC1313 (F. G. H) Transistor	A
IC01	0360190	BA312 IC	
C01	0573687	0.068 $\mu$ F 25V T.C.	A
VR01	1005290, 1	20k $\Omega$ Volume	A, B
J01	2430240	Mic Jack	A
MODEL 9090DB/990DB Only			
C08	0620561	560pF 50V P.C.	B

5-8. F-2619 Power Supply Circuit Board of RF Section (Stock No. 7501921 MODEL 8080DB/890DB)  
(Stock No. 7501991 MODEL 9090DB/990DB)

Conductor Side

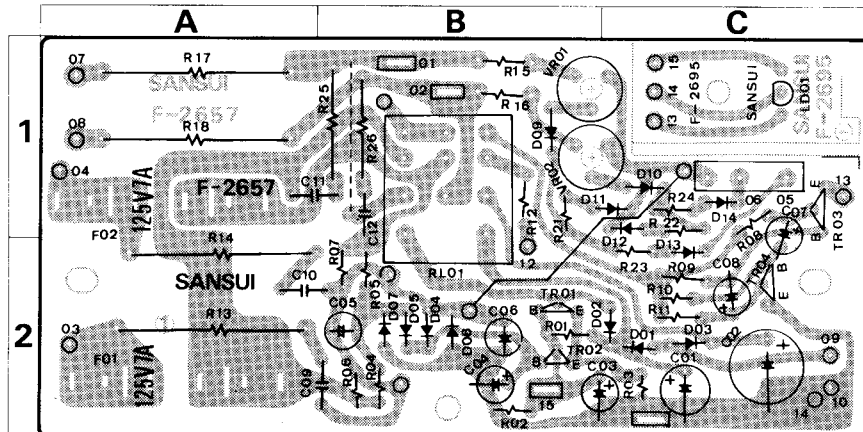


Parts List

Parts No.	Stock No.	Description	Position
TR01	0308391-3	2SD313 (D. E. F) } Transistor	A
TR02	0305930.1	2SC1211 (C. D) } Transistor	A
TR03	0306131.2	2SC1364 (6. 7) } Transistor	B
D01	0310340	10D1 Diode	B
ZD01	0315760	EQA01-06R Zener Diode	B
R01	0133330	33 $\Omega$	B
R02	0133330	33 $\Omega$ 3 W Ca.R.	A
VR01	1035130	10k $\Omega$ (B) Volume	B

5-9. F-2657 Power Relay Circuit Board (Stock No. 7501901 MODEL 8080DB/890DB)  
(Stock No. 7501971 MODEL 9090DB/990DB)

Conductor Side



Parts List

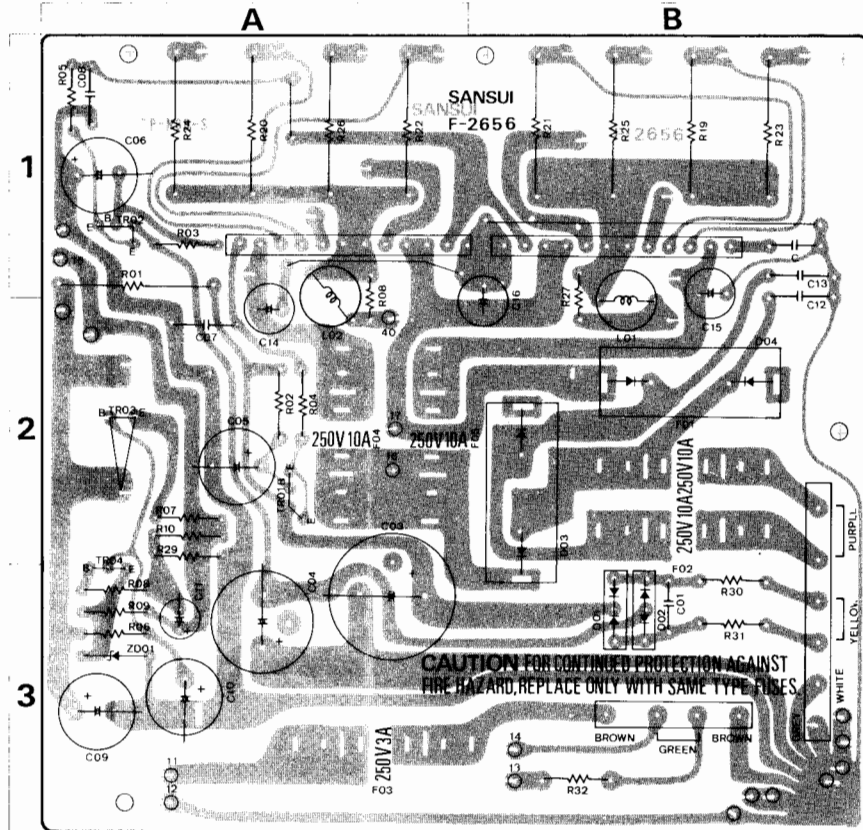
Parts No.	Stock No.	Description	Position
TR01	0305953	2SC945 (K) } Transistor	2 B
TR02	0305951-3	2SC945 (Q. P. K) } Transistor	2 B
TR03, 04	0305952, 3	2SC945 (P. K) } Transistor	1 C, 2 C
D01	0310340	10D1	2 C
D02	0310340	10D1	2 C
D03	0310340	10D1	2 C
D04	0310330, 1	1N60	2 B
D05	0310330, 1	1N60	2 B
D06	0310330, 1	1N60	2 B
D07	0310330, 1	1N60	2 B
D09, 10	{ 0310970 0311060	1N60P 1N60-P	1 B, 1 C
D11, 12	{ 0311160 0311180	1S2473D 1S1588	1 C, 2 C
D13, 14	{ 0310970 0311060	1N60P 1N60-P	2 C, 1 C
R13, 14	0192479	4.7 $\Omega$ 1/2 W Fuse R.	2 A
R15, 16	0201101	100 $\Omega$ 1 W M.R.	1 B
R17, 18	0135221	220 $\Omega$ 5 W Ca.R.	1 A
R25, 26	0203100	10 $\Omega$ 3 W M.R.	1 B
RL01	1150390	Relay	1 B
VR01, 02	1035350	4.7k $\Omega$ (B) Volume	1 B
F01, 02	0432500	7A 125V Speaker Fuse	2 A, 1 A



### 5-10. F-2656 Power Supply Circuit Board

(Stock No. 7501911 MODEL /890DB)  
(Stock No. 7501981 MODEL /990DB)

Conductor Side



#### Parts List

Parts No.	Stock No.	Description	Position
TR01	0306171.2	2SC1509 (Q, R)	2A
	0308520.1	2SD438 (D, E)	
TR02	0300591.2	2SA777 (Q, R)	1A
	0303360.1	2SB560 (D, E)	
TR03	0306351.2	2SC1024 (D, E)	3A
	0308551.2	2SD315V10 (D, E)	
TR04	0305930.1	2SC1211 (C, D)	3A
D01	0310800	10DC2	3B
D02	0310801	10DC2R	3B
D03	0311310	SS-5	2B
D04	0311320	SS-5R	2B
ZD01	0315970	EQA01-13R Zener Diode	3A
C01	0655103	10000 pF 500V C.C.	3B
C03	0549302	1000 pF 80V E.R.	3A
C04	0549301	470 pF 80V E.R.	3A
C07, 08	0655103	10000 pF	2A, 1A
C12, 13	0655103	10000 pF	1B
R01	0135560	56 Ω	1A
R19, 20	0135338	0.33 Ω	1B, 1A
R21, 22	0135338	0.33 Ω	1B, 1A
R27, 28	0103479	4.7 Ω 1/2W C.R.	1B, 1A
R30, 31	0192109	1.0 Ω	3B
R32	0192109	1.0 Ω	3B
L01, 02	4290210	Filter Coil	1, 2A B
F03	0432260	3A 250V AC Fuse	3A
	2410730	6P Pin Ass'y Type A	
	2410950	6P Pin Ass'y Type E	
	2420510	4P Connector Ass'y Type A	
<b>MODEL 8080DB/890DB Only</b>			
F01, 02	0432500	7A 125V AC Fuse	
F04, 05	0432500	7A 125V Q.A. Fuse	
<b>MODEL 9090DB/990DB Only</b>			
R23, 24	0135338	0.33 Ω	1B, 1A
R25, 26	0135338	0.33 Ω	1B, 1A
F01, 02	0431320	10A 250V AC Fuse	
F04, 05	0431320	10A 250V Q.A. Fuse	

### 5-11. F-2684 Connector Circuit Board (C)

(Stock No. 7594491 MODEL 8080DB/890DB) (Stock No. 7594441 MODEL 9090DB/990DB)

#### Parts List

Parts No.	Stock No.	Description
	2411030	6P Mini Pin Ass'y
	2411150	6P Mini Pin Ass'y

### 5-12. F-2682 Connector Circuit Board (A)

(Stock No. 7594471 MODEL 8080DB/890DB) (Stock No. 7594451 MODEL 9090DB/990DB)

#### Parts List

Parts No.	Stock No.	Description
	2411180	9P Mini Pin Ass'y

### 5-13. F-2683 Connector Circuit Board (B)

(Stock No. 7594481 MODEL 8080DB/890DB) (Stock No. 7594461 MODEL 9090DB/990DB)

#### Parts List

Parts No.	Stock No.	Description
	2411150	6P Mini Pin Ass'y MODEL 8080DB only

### 5-14. F-2692 Connector Circuit Board

(Stock No. 7594881 MODEL 8080DB/890DB) (Stock No. 7594871 MODEL 9090DB/990DB)

### 5-15. F-2695 LED Ass'y Circuit Board

(Stock No. 7594621 MODEL 8080DB/890DB) (Stock No. 7594611 MODEL 9090DB/990DB)

#### Parts List

Parts No.	Stock No.	Description
LD01	0319040	GL-40R8 LED

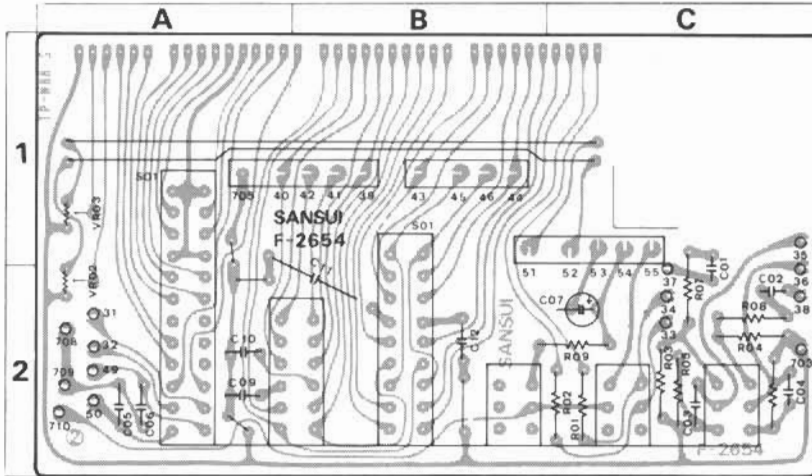
#### Abbreviations

<b>C.R.</b> : Carbon Resistor	<b>N.I.R.</b> : Non-Inflammable Resistor	<b>C.C.</b> : Ceramic Capacitor
<b>S.R.</b> : Solid Resistor	<b>M.C.</b> : Mylar Capacitor	<b>Mi.C.</b> : Mica Capacitor
<b>Ce.R.</b> : Cement Resistor	<b>E.C.</b> : Electrolytic Capacitor	<b>O.C.</b> : Oil Capacitor
<b>M.R.</b> : Metallized Film Resistor	<b>BP.E.C.</b> : Bi-Polar Electrolytic Capacitor	<b>P.C.</b> : Polystyrene Capacitor
<b>F.R.</b> : Fusing Resistor		<b>T.C.</b> : Tantalum Capacitor

**5-16. F-2654 Push Switch Circuit Board** (Stock No. 7594181 MODEL 8080DB/890DB)  
(Stock No. 7594271 MODEL 9090DB/990DB)

Conductor Side

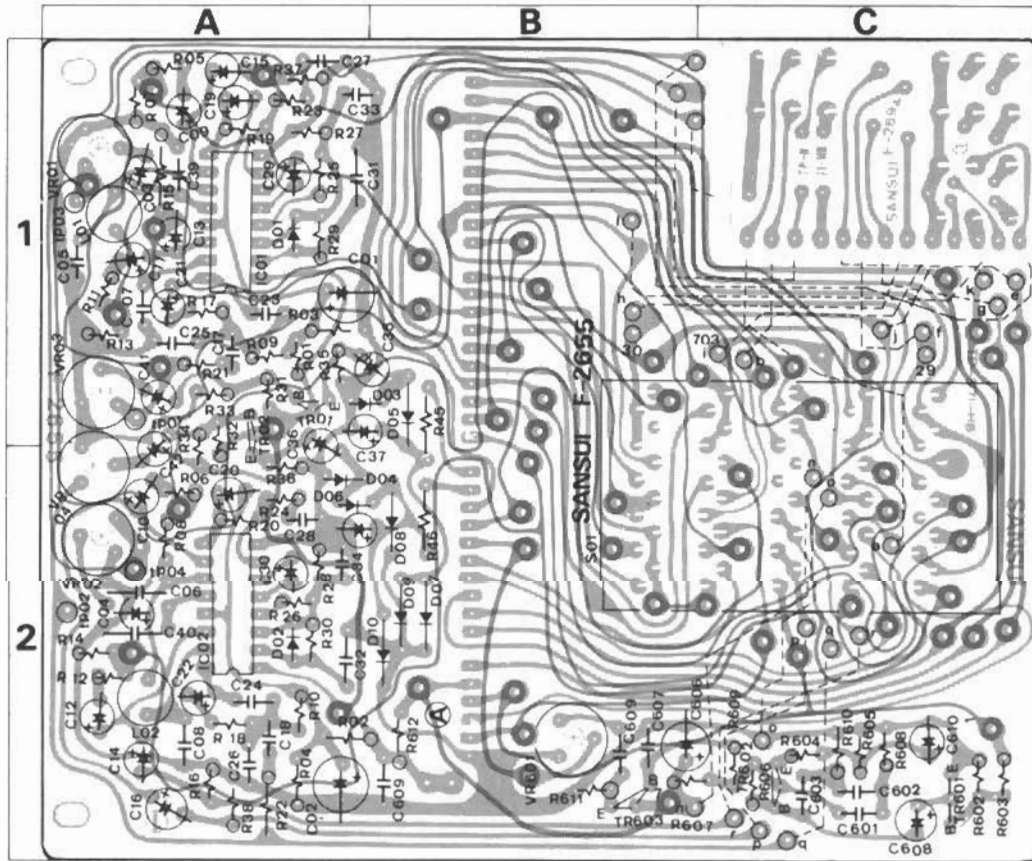
Parts List



Parts No.	Stock No.	Description
Co1.02	0620331	330pf 50V P.C.
S01	1131380	Push Switch
	2410570	5P Pin Ass'y Type D
	2410590	4P Pin Ass'y Type D
	2410690	5P Pin Ass'y Type F

**5-17. F-2655 Dolby NR Circuit Board** (Stock No. 7660041 MODEL 8080DB/890DB)  
(Stock No. 7660051 MODEL 9090DB/990DB)

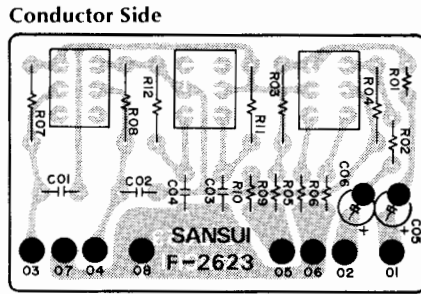
Conductor Side



Parts List

Parts No.	Stock No.	Description	Position	Parts No.	Stock No.	Description	Position	Parts No.	Stock No.	Description	Position
TR01.02	0305951.2	2SC945 (Q, P)	1 A	D05	0310970	1N60P	1 B	VR01.02	1035190	100kΩ (8)	1 A, 2 A
TR01	0305951.2	2SC945 (Q, P)	2 C	D07, 08	0311060	1N60-P	2 B	VR03.04	1035170	47kΩ (8)	S.R. 1 A, 2 A
TR02	0305951.2	2SC945 (Q, P)	2 C		D09, 10	0310970		1N60P	2 B	VR05	1065051
TR03	0305951.2	2SC945 (Q, P)	2 B		3011060	1N60-P		VR04		1015221	47kΩ (8)
IC01.02	0360340	NE5458 IC	1 A, 2 A		0310970	1N60P		VR01	1035170	47kΩ (8)	2 B
D01.02	0310403	1N34A	1 A, 2 A		0311060	1N60-P		S01	1105220	Rotary Switch	2 C
D03	0310970	1N60P	1 A, B	Co3.04	0573109	1μF 35V T.C.	1 A, 2 A				
	0311060	1N60-P		L01.02	4900260	Inductor	1 A, 2 A				

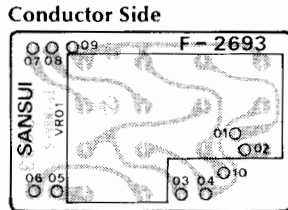
### 5-18. F-2623 Filter Circuit Board (Stock No. 7594201 MODEL 8080DB/890DB) (Stock No. 7594291 MODEL 9090DB/990DB)



#### Parts List

Parts No.	Stock No.	Description
S01	1131170	Push Switch
	2410590	4P Pin Ass'y Type D

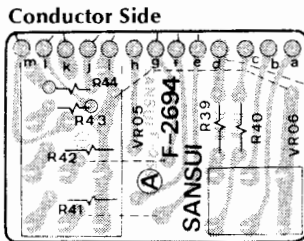
### 5-19. F-2693 Push Switch Circuit Board (Stock No. 7594841 MODEL 8080DB/890DB) (Stock No. 7594831 MODEL 9090DB/990DB)



#### Parts List

Parts No.	Stock No.	Description
VR01	1060320.1	250kΩ M.N (8) × 2 Volume

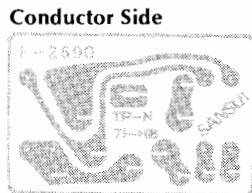
### 5-20. F-2694 Dolby Volume Circuit Board (Stock No. 7594861 MODEL 8080DB/890DB) (Stock No. 7594851 MODEL 9090DB/990DB)



#### Parts List

Parts No.	Stock No.	Description
VR05	1065060	500kΩ (8) × 4
VR06	1015220	500kΩ (8) × 2

### 5-21. F-2690 DIN Terminal Circuit Board (Stock No. 7594191 MODEL 8080DB/890DB) (Stock No. 7594281 MODEL 9090DB/990DB)



#### Parts List

Parts No.	Stock No.	Description
J01	2090030	5P Connector Socket

### 5-22. Figures Connectors & Pin Ass'y

#### Connectors

Type A (3~10 pins)	Type B (2~6 pins)	Stock No.
		2 Pins 2420450
		3 Pins 2420460
		3 Pins(RTD) 2420650
		4 Pins 2420470
		5 Pins 2420480
		6 Pins 2420490

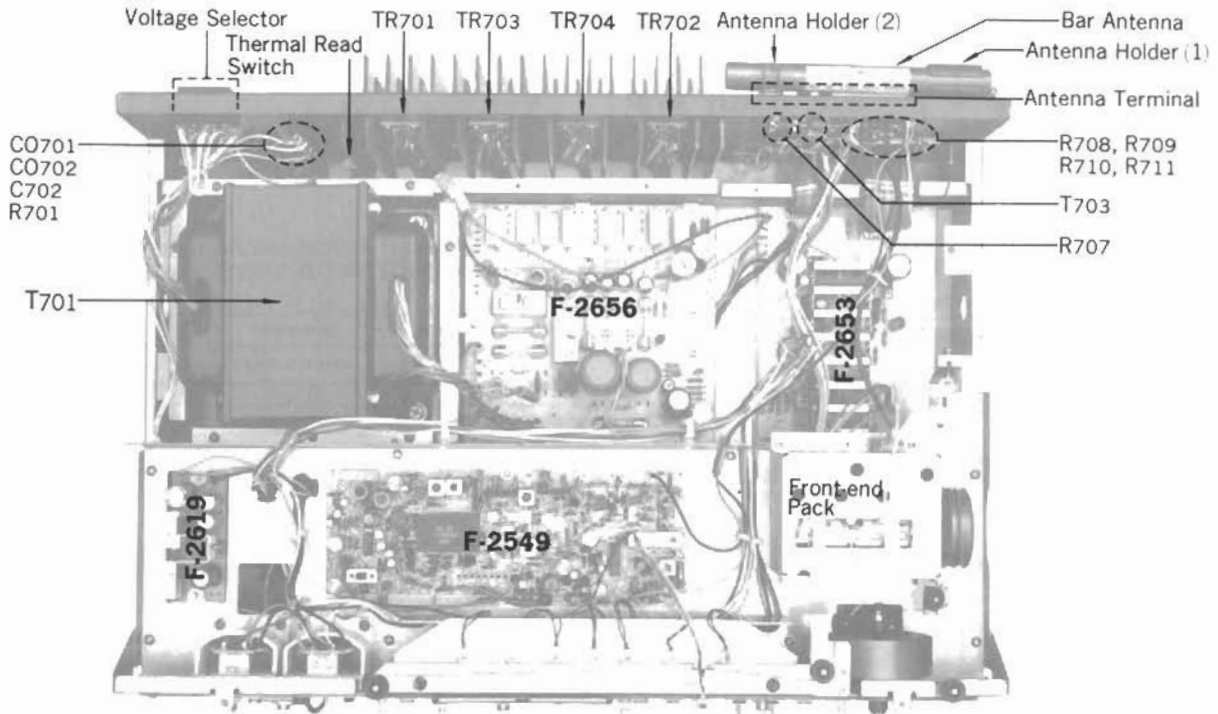
NOTE: Since stock number of female connectors (type B) with wires are not shown in each parts list of Complete circuit board, please refer to the above parts list when ordering the connector.

#### Pin Ass'y

Type A (3~10 pins) 	Type B (3~10 pins) 	Type C (3~10 pins) 
Type D (2~6 pins) 	Type E (2~6 pins) 	Type F (2~6 pins) 

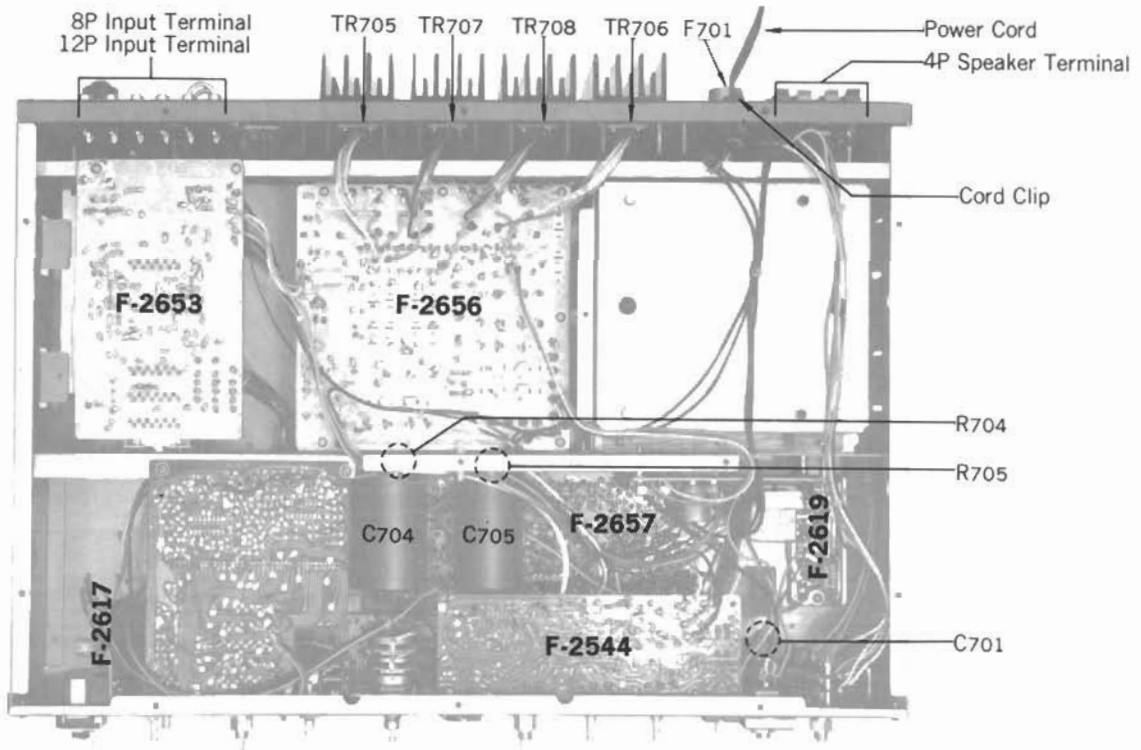
## 6. OTHER PARTS

### 6-1. Top Side



(9090DB/990DB)

### 6-2. Bottom Side



(9090DB/990DB)

## Parts List (Top Side & Bottom Side)

Parts No.	Stock No.	Description	Position
C701	0605337	0.033 $\mu$ F 250V M.C.	
C702	0659802	0.0047 $\mu$ F 150V C.C.	
R701	0114335	3.3M $\Omega$ $\frac{1}{2}$ W S.R.	
R704, 705	0104472	4.7k $\Omega$ 1W C.R.	
R707	0103122	1.2k $\Omega$ $\frac{1}{2}$ W C.R.	
T702	4200760	Bar Antenna	
T703	4290021	75 $\Omega$ /300 $\Omega$ Balun	
S703	1900020	Thermal Reed Switch	
	2300060	Power Fuse Holder	
CO701, 702	2450060	AC Outlet	
	2200450	8P Input Terminal	
	2200490	12P Input Terminal	
	2210310	Antenna Terminal	
	2230150	Ground Terminal	
	2290160	4P Speaker Terminal	
	2410091	Voltage Selector, plug	
	2410830	Voltage Selector, socket	
	3800010	Power Cord	
	3910490	Cord Clip, power cord	
	5286450	Antenna Holder (1)	
	5286480	Antenna Holder (2)	
	3910510	Cord Clip, antenna	

### 8080DB/890DBOnly

TR701, 702	0305840	2SC1116 (R)	} Transistor
	or	or	
	0305841	2SC1116 (O)	
TR703, 704	0300520	2SA747 (R)	
	or	or	
	0300521	2SA747 (O)	
C703, 704	0559518	12000 $\mu$ F 63V E.C.	
T701	4002540	Power Transformer	
F701	0432280	4A, 125V (AC 220~240V)	
	0432500	7A, 125V (AC 100~120V)	

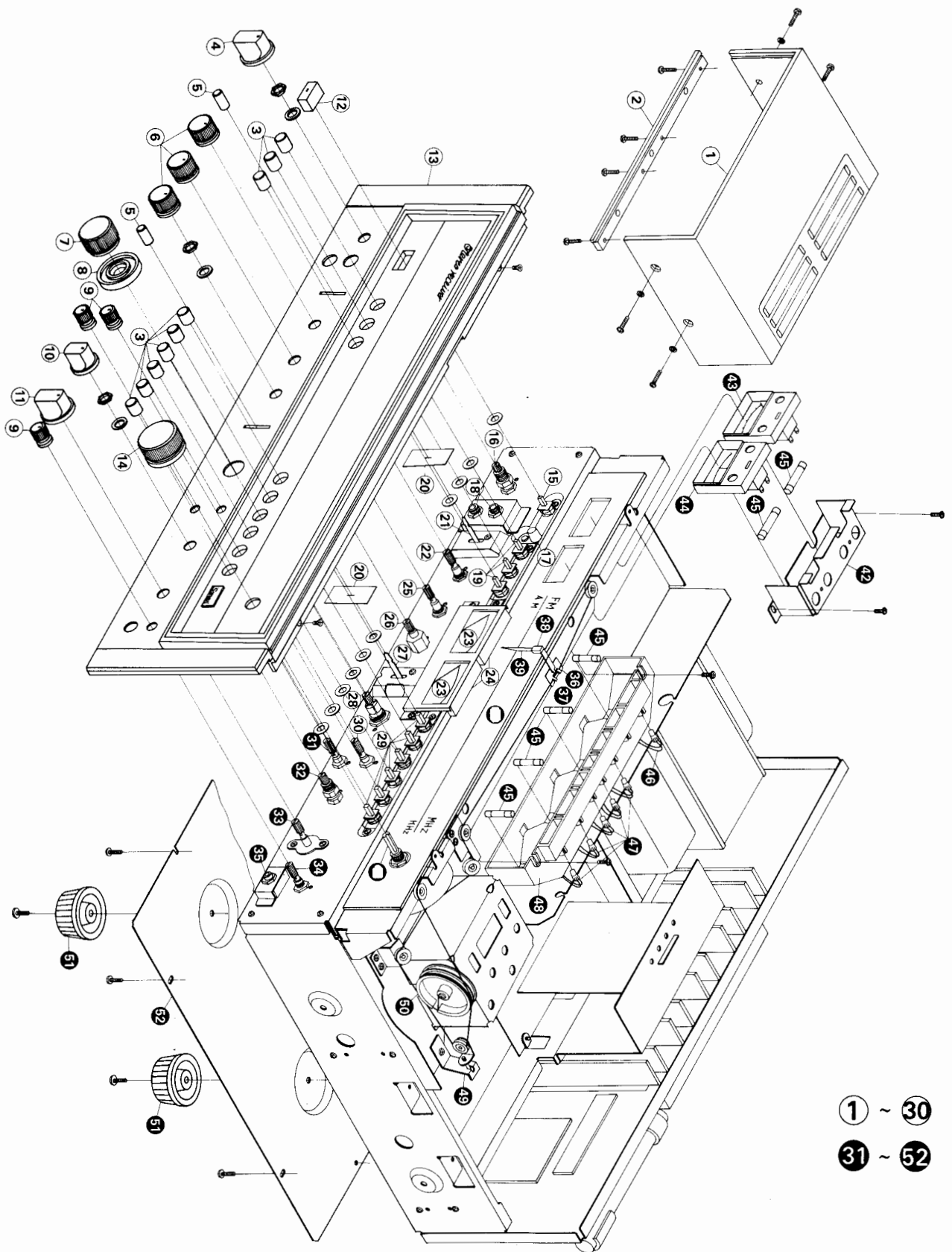
### 9090DB/990DBOnly

TR701, 702	0308470	2SD424 (R)	} Transistor
	or	or	
	0308471	2SD424 (O)	
TR703, 704	0303300	2SB554 (R)	
	or	or	
	0303301	2SB554 (O)	
TR705, 706	0308470	2SD424 (R)	
	or	or	
	0308471	2SD424 (O)	
TR707, 708	0303300	2SB554 (R)	
	or	or	
	0303301	2SB554 (O)	
C703, 704	0559844	12000 $\mu$ F 80V E.C.	
T701	4002530	Power Transformer	
F701	0432500	7A, 125V (AC 220~240V)	
	0434060	10A, 250V (AC 100~120V)	

## Parts List (Exploded View)

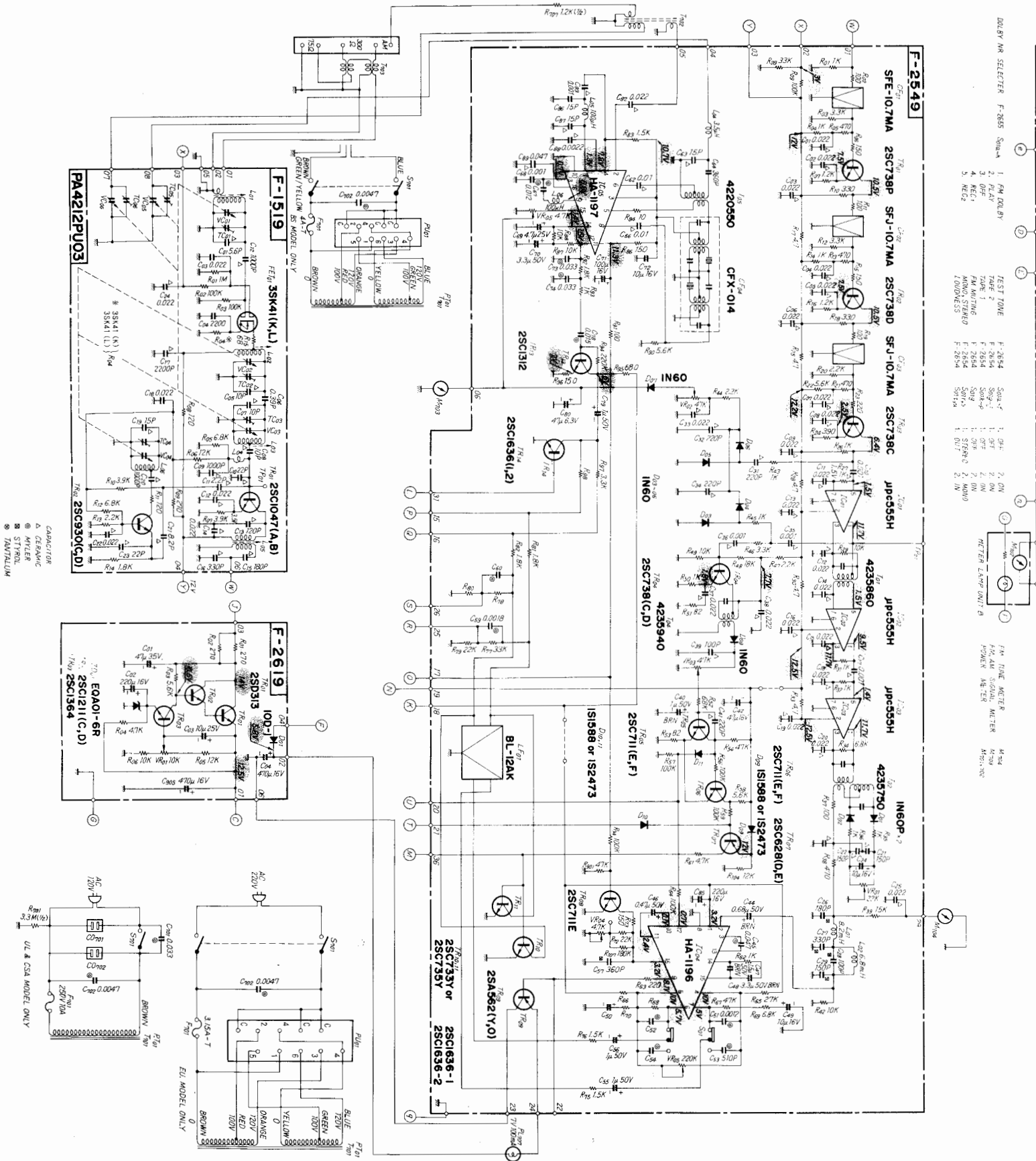
Parts No.	Stock No.	Description
1	5726923	Bonnet (8080DB/890DB)
	5726933	Bonnet (9090DB/990DB)
2	5996104	Panel Sash (8080DB)
	5996098	Panel Sash (9090DB)
	5996104	Panel Sash (890DB)
	5996093	Panel Sash (990DB)
3	5326560	Push Knob (890DB/990DB)
	5326550	Push knob (8080DB/9090DB)
4	5318380	Speakers Knob, M-7 Type (8080DB/890DB)
	5318400	Speakers Knob, E-2 Type (9090DB/990DB)
5	7106130	Lever Switch Knob, C-2 Type (9090DB/990DB)
6	5318410	S-10 Type Knob
7	5318440	Volume Knob, WI-6 Type
8	5318431	Balance Volume Knob, WO-8 Type
9	5318340	N-6 Type Knob
10	5318410	S-10 Type Knob (8080DB/890DB)
	5318390	E-1 Type Knob (9090DB/990DB)
11	5318380	M-7 Type Knob (8080DB/890DB)
	5318400	E-2 Type Knob (9090DB/990DB)
12	5326570	Push Botton
13	7007450	Front Panel Ass'y (8080DB)
	7007430	Front Panel Ass'y (890DB)
	7007420	Front Panel Ass'y (990DB)
	7007440	Front Panel Ass'y (9090DB)
	5309840	Panel Window } 8080DB/890DB
	5336500	Sansui Mark } 9090DB/990DB
	5446330	Smoked Plate (8080DB)
	5446310	Smoked Plate (9090DB)
	5446340	Smoked Plate (890DB)
	5446320	Smoked Plate (990DB)
14	5318420	Tuning Knob, T-12 Type (8080DB/9090DB)
	5318450	Tuning Knob, T-13 Type (890DB/990DB)
15	1131190	Power Switch
16	1104360, 1	Speakers Switch
17	0319040	Power Indicator, LED
18	2430190	Head Phone Jack
19	1131270	Push Switch
20	5047470	Masking, Lever Switch (9090DB/990DB)
21	1171220	Bass Selector (9090DB/990DB)
22	1010930, 1	Bass Volume, 100k $\Omega$ B
23	4301010	Power Meter
24	7726180	Power Meter Circuit Board
25	1010930, 1	Midrange Volume, 100k $\Omega$ B
26	1010930, 1	Treble Volume, 100k $\Omega$ B
27	1171240	Treble Selector (9090DB/990DB)
28	1060320, 1	Master & Balance Volume
29	1131380	Push Switch
30	1015220, 1	PLAY CAL Control Volume, 50k $\Omega$ $\times$ 2
31	1065051	REC LEVEL Control, 500k $\Omega$ B $\times$ 4
32	1105220	Dolby NR Switch
34	1005290, 1	MIC Volume, 20k $\Omega$
35	2430240	MIC Jack
36	5416350	Holder Dial Pointer
37	5516030	Teflon Sheet
38	0400450	Dial Pointer Lamp
39	5416050	Dial Pointer
40	5408120	Dial Glass
41	7036453	Tuning Unit
42	5288390	Meter Holder
43	4300740	Signal Meter
44	4300750	Tune Meter
45	0420040	Meter Lamp
46	0400420	FM Stereo Indicator
47	0400540	Indicator Lamp
48	5066211	Illumination Box
49	7136082	Tension Unit
50	6146670	Dial pulley, D-44
51	5517050	Leg
52	5058512	Bottom Plate (8080DB/9090DB)
	505811	Bottom Plate (890DB/990DB)

6-3. Exploded View

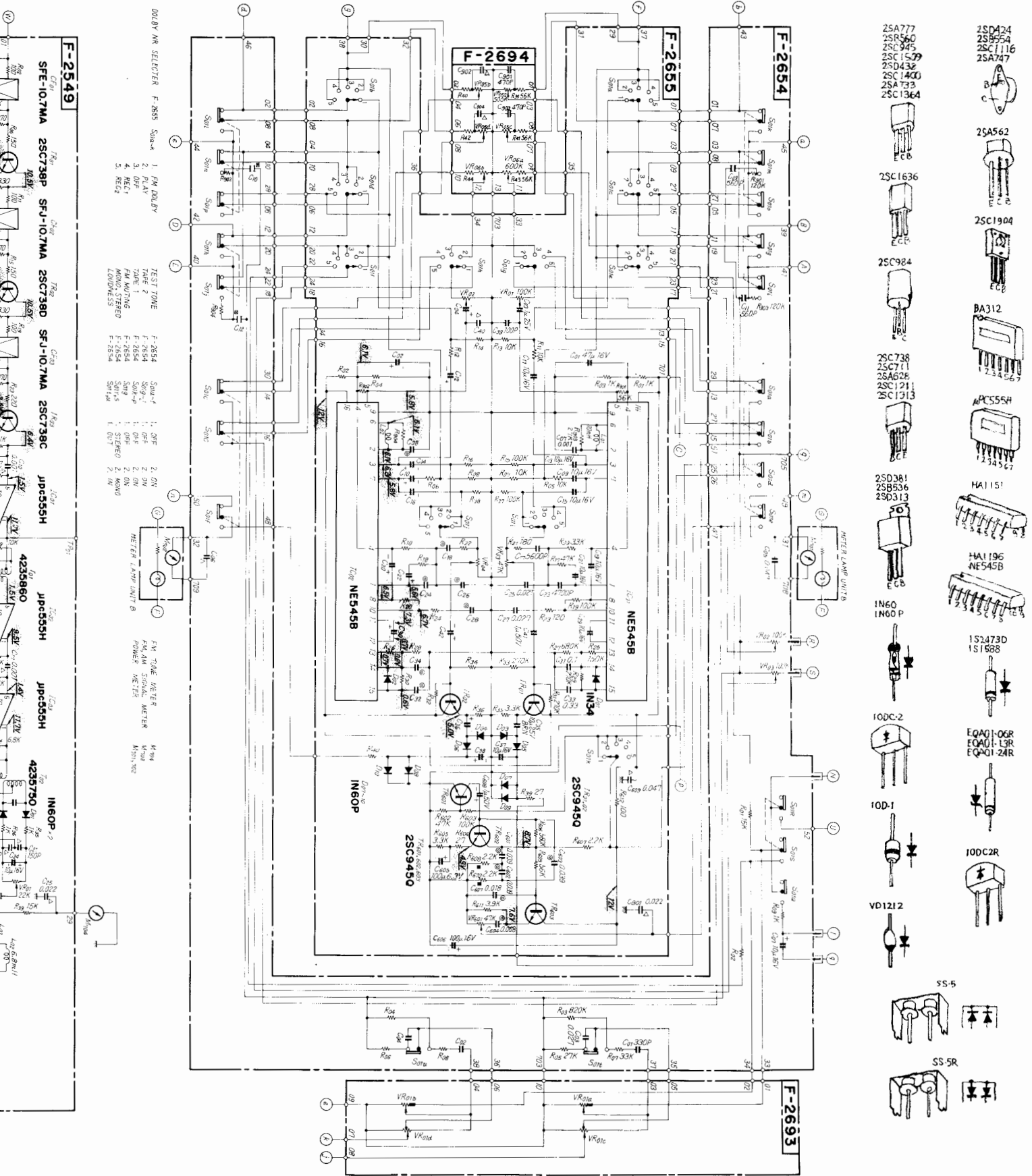


- ① ~ ③①
- ③① ~ ⑤②

# 7. SCHEMATIC DIAGRAM 7-1. Tuner Section (8080DB/9090DB,890DB/990DB)



\* La présentation et les spécifications sont susceptibles d'être modifiées sans préavis par suites d'améliorations éventuelles.  
 \* Änderungen, die dem technischen Fortschritt dienen, bleiben vorbehalten.  
 \* Design and specifications subject to change without notice for improvements.



- DELAY VM SELECTOR F-2655 S01-A
1. FM DELAY
  2. PLAY
  3. OFF
  4. RECT
  5. RECT
- TEST TONE
- |        |       |        |       |
|--------|-------|--------|-------|
| F-2654 | S01-A | 1. OFF | 2. ON |
| F-2654 | S01-B | 1. OFF | 2. ON |
| F-2654 | S01-C | 1. OFF | 2. ON |
| F-2654 | S01-D | 1. OFF | 2. ON |
| F-2654 | S01-E | 1. OFF | 2. ON |
| F-2654 | S01-F | 1. OFF | 2. ON |
| F-2654 | S01-G | 1. OFF | 2. ON |
| F-2654 | S01-H | 1. OFF | 2. ON |
| F-2654 | S01-I | 1. OFF | 2. ON |
| F-2654 | S01-J | 1. OFF | 2. ON |
- FM TONE METER  
 FM AM SIGNAL METER  
 POWER METER  
 METER

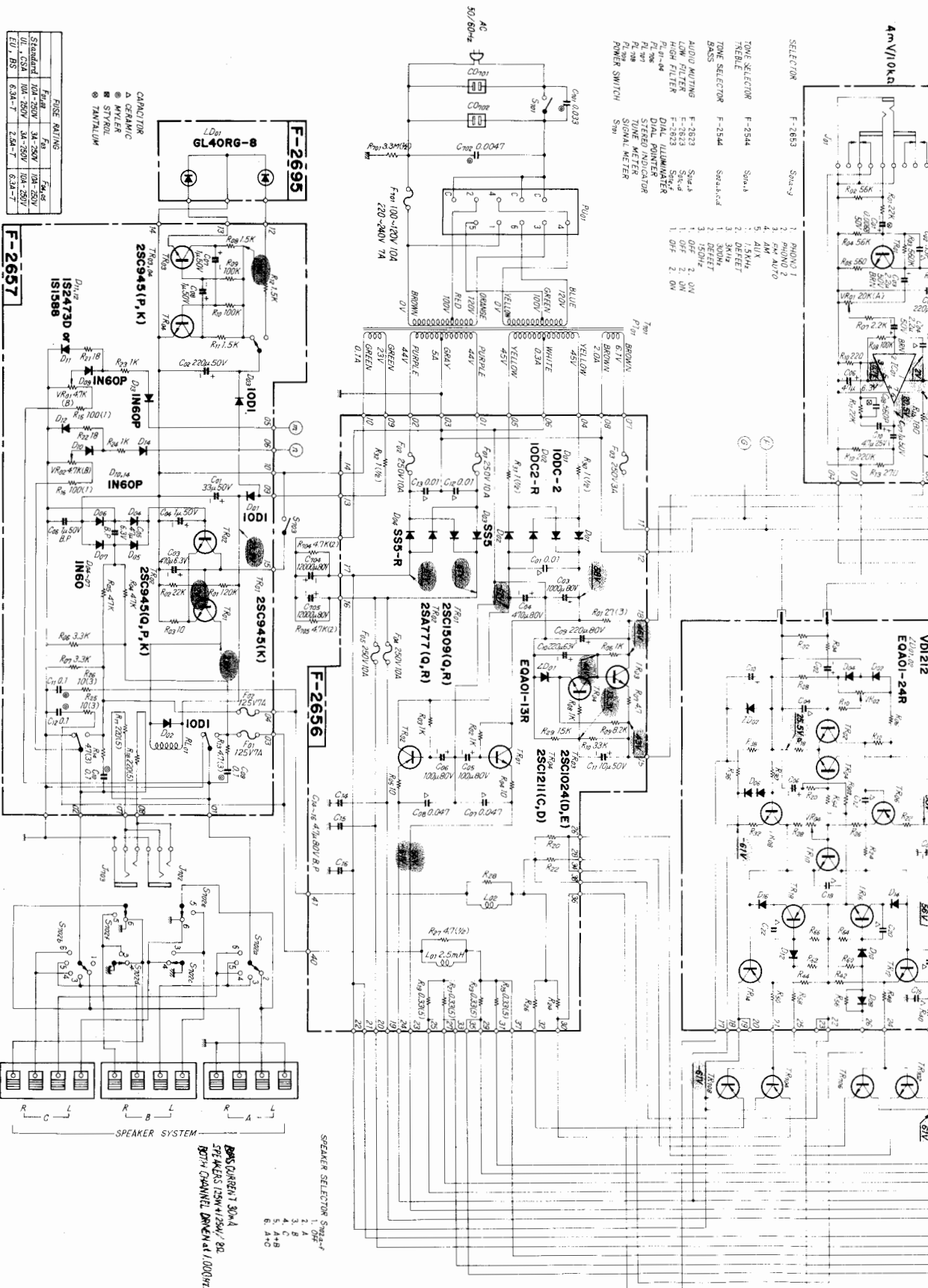
- 2SA777
- 2SR560
- 2SC945
- 2SC1157
- 2SD432
- 2SC1400
- 2SA733
- 2SC1364
- 1SD424
- 2SR554
- 2SC1116
- 2SA747
- 2SA562
- 2SC1636
- 2SC1904
- 2SC924
- BA312
- 2SC738
- 2SC711
- 2SA628
- 2SC1211
- 2SC1313
- PC555H
- HA1151
- HA1196
- NE545B
- 2SD381
- 2SB536
- 2SD313
- IN60
- IN60P
- IS2473D
- IS1688
- EQ401-0GR
- EQ401-1SR
- EQ401-2AR
- 10DC-2
- 10D-1
- 10DC2R
- VD1212
- SS-5
- SS-SR



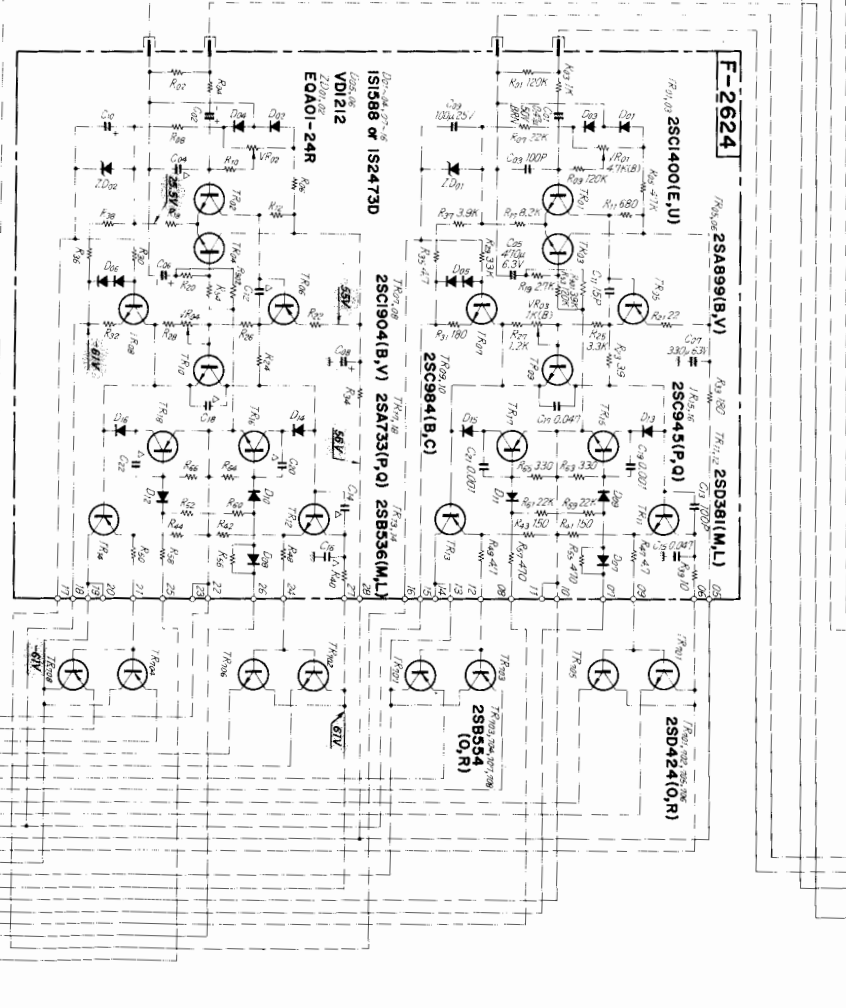
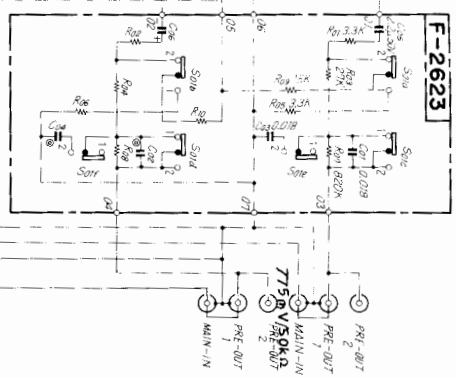
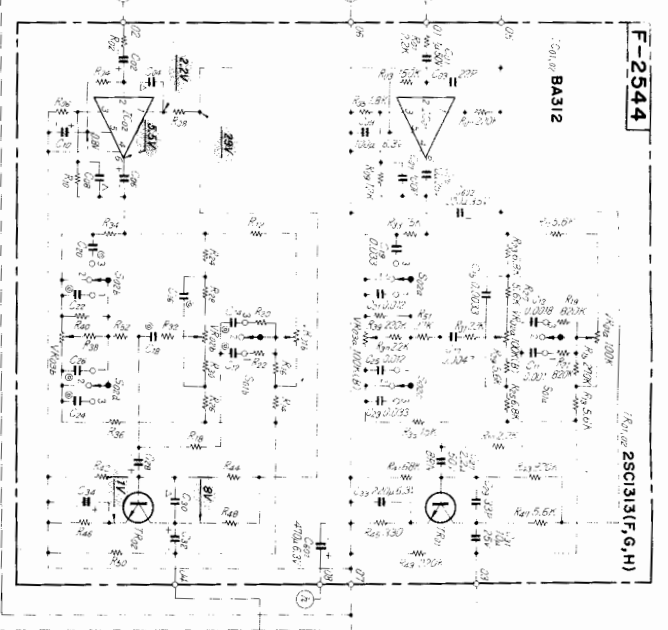
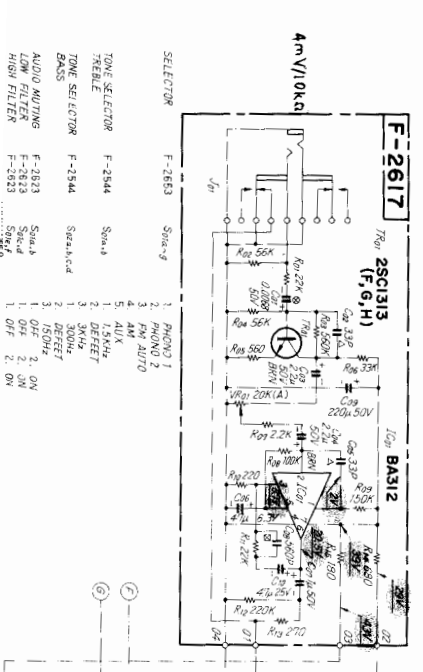
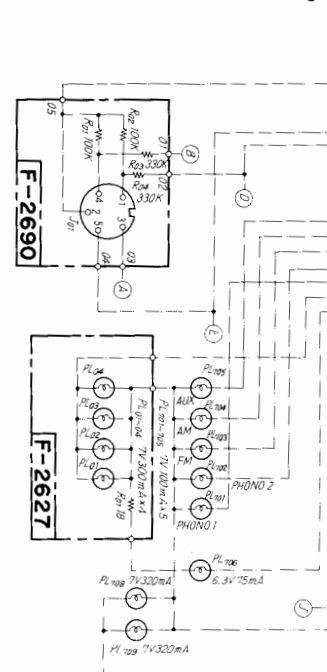
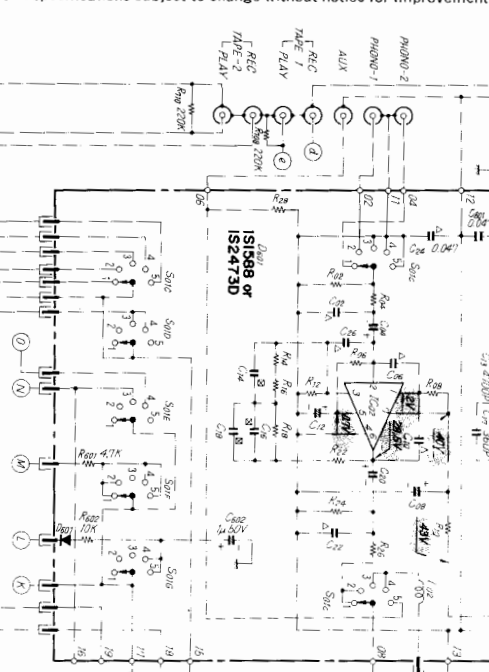
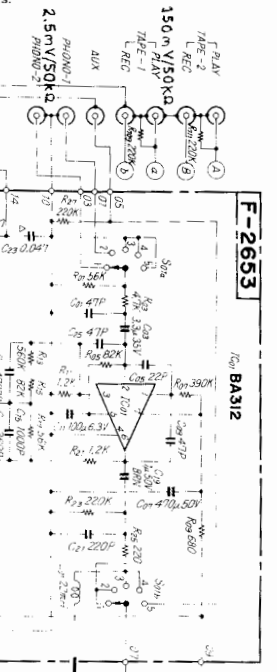




**7-3. Audio Section (9090DB/990DB)**



• La présentation et les spécifications sont susceptibles d'être modifiées sans préavis par suites d'améliorations éventuelles.  
 • Änderungen, die dem technischen Fortschritt dienen, bleiben vorbehalten.  
 • Design and specifications subject to change without notice for improvements.



- SELECTOR**
- F-26E3 1. STEREO
  - 2. PHONO 1
  - 3. AM AUTO
  - 4. AM
  - 5. AUX
- TOUR SELECTOR**
- F-2644 1. 1.5KHz
  - F-2644 2. 3KHz
  - F-2644 3. 4.5KHz
  - F-2644 4. 6KHz
  - F-2644 5. 7.5KHz
  - F-2644 6. 9KHz
  - F-2644 7. 10.5KHz
  - F-2644 8. 12KHz
  - F-2644 9. 13.5KHz
  - F-2644 10. 15KHz
  - F-2644 11. 16.5KHz
  - F-2644 12. 18KHz
  - F-2644 13. 19.5KHz
  - F-2644 14. 21KHz
  - F-2644 15. 22.5KHz
  - F-2644 16. 24KHz
  - F-2644 17. 25.5KHz
  - F-2644 18. 27KHz
  - F-2644 19. 28.5KHz
  - F-2644 20. 30KHz
- AUDIO MUTING**
- F-2623 1. ON
  - F-2623 2. OFF
  - F-2623 3. OFF
  - F-2623 4. OFF
  - F-2623 5. OFF
  - F-2623 6. OFF
  - F-2623 7. OFF
  - F-2623 8. OFF
  - F-2623 9. OFF
  - F-2623 10. OFF
  - F-2623 11. OFF
  - F-2623 12. OFF
  - F-2623 13. OFF
  - F-2623 14. OFF
  - F-2623 15. OFF
  - F-2623 16. OFF
  - F-2623 17. OFF
  - F-2623 18. OFF
  - F-2623 19. OFF
  - F-2623 20. OFF

## 8. THREADING OF DIAL CORD

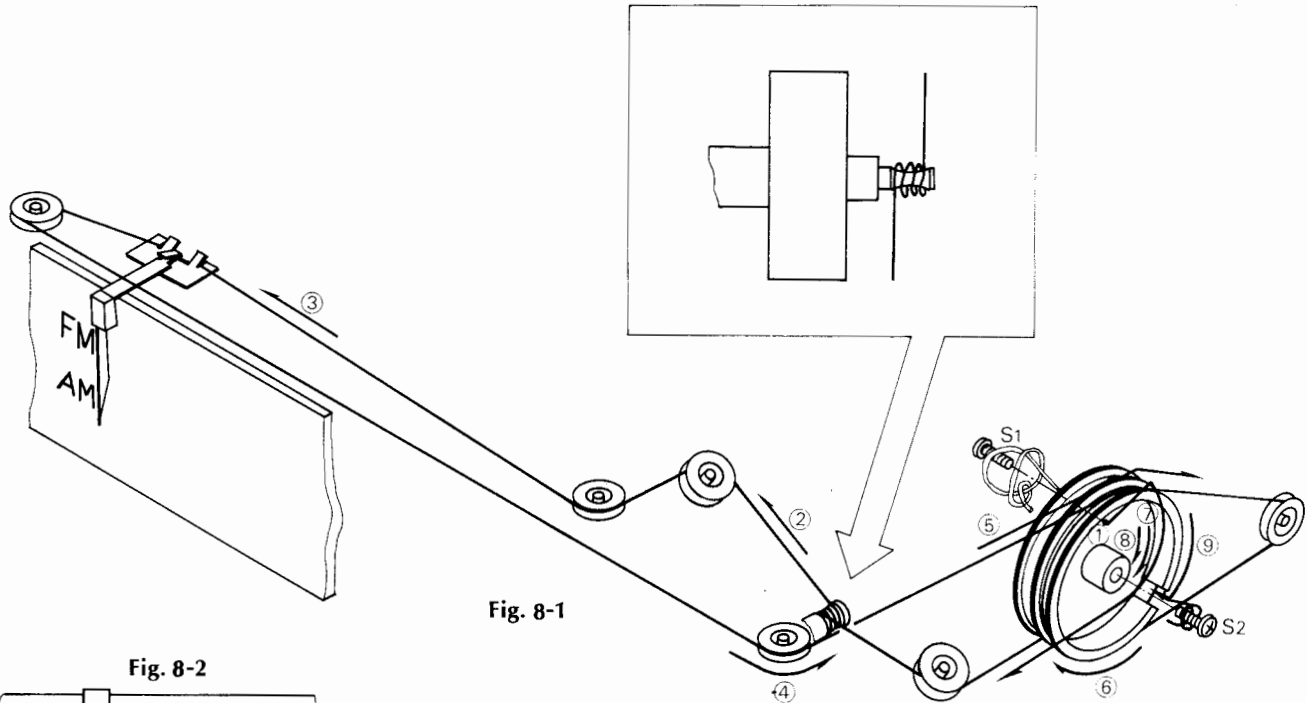


Fig. 8-1

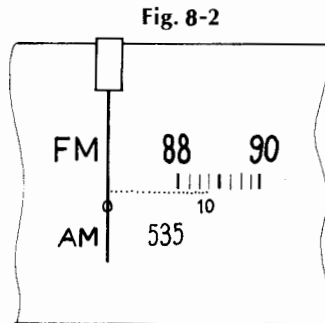


Fig. 8-2

\*If a dial cord is cut off or slips, replace it by following procedures.  
As these units use 0.6mm $\phi$  cord, please replace it with the same type certainly.  
\*The length of dial cord is approximately 155cm (63 inch)

### 8-1. Threading of Dial Cord

Thread the dial cord in numerical order from ① to ⑨ as Fig. 8-1.

- 1) Close the variable capacitor completely (Max. capacitance).
- 2) Tie dial cord to the screw, S1 .
- 3) Thread cord in the direction of arrow from ① to ⑨
- 4) After ⑨, tie the cord to the screw S2 of the dial pulley.

### 8-2. Attachment of Dial Pointer

- 1) Close the variable capacitor completely.
- 2) Set the dial pointer to the 0 position on dial scale (Fig. 8-2).

\*Confirm that the dial pointer runs smoothly on the dial scale by turning the tuning shaft.

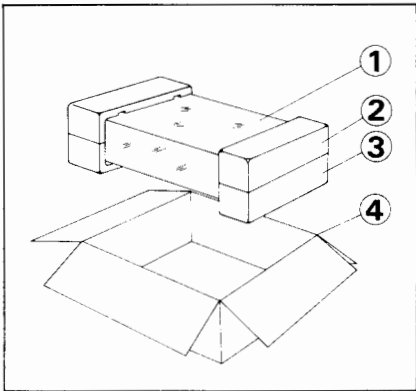
Stock No.	Description
6036051	Dial Cord (0.6mm $\phi$ )
6146670	D44 Type Pulley

## 9. PACKING LIST

Parts No.	Stock No.	Description
1	9116271	Vinyl Cover
	9126070	Polyethylene Sheet
2	9027940	Styrofoam Packing (Upper)
3	9027930	Styrofoam Packing (Lower)
4	9009260	Carton Case (8080DB)
	9009270	Carton Case (9090DB)
	9009380	Carton Case (890DB)
	9009370	Carton Case (990DB)
	5996080	Curl Stopper

## 10. ACCESSORY PARTS LIST

Parts No.	Stock No.	Description
	9202380	Operating Instructions (8080DB)
	9202390	Operating Instructions (9090DB)
	9209740	Operating Instruction (890DB)
	9209730	Operating Instruction (890DB)
	9237520	Schematic Diagram (890DB)
	9237530	Schematic Diagram (990DB)
	9237420	Schematic Diagram (8080DB)
	9237410	Schematic Diagram (9090DB)



**SANSUI ELECTRIC CO., LTD.**

14-1 Izumi 2-Chome, Suginami-ku, TOKYO 168 JAPAN  
TELEPHONE: (03) 323-1111/TELEX. 232-2076

SM071

Printed in Japan (D60720M)