

SERVICE MANUAL

INTEGRATED STEREO AMPLIFIER

SANSUI A-60 (Silver & Black Model)

A-80 (Silver & Black Model)

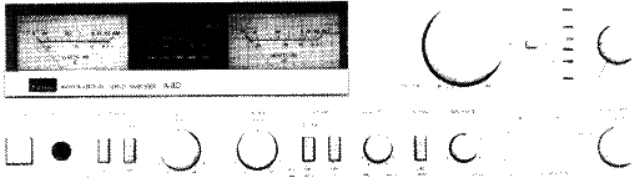

Sansui

SANSUI ELECTRIC CO., LTD.

SPECIFICATIONS

●A-60

Power output

Min. RMS, both channels driven, from 20 to 20,000 Hz,
with no more than 0.05 % total harmonic distortion
45 watts per channel into 8 ohms

Load impedance 8 ohms

Total harmonic distortion

less than 0.05 % at or below rated
min. RMS power output

Frequency response (at 1 watt)

5 to 70,000 Hz +0.5 dB, -2 dB

RIAA curve deviation (PHONO, 30 Hz to 15 kHz)

+0.8 dB, -0.8 dB

Input sensitivity and impedance (1 kHz, for rated power output)

PHONO 2.5 mV/47 kilohms

(Max. input capability; 160 mV at 1 kHz, less than
0.1 % total harmonic distortion)

AUX, TUNER, TAPE PLAY

150 mV/47 kilohms

Output level and impedance (1,000 Hz)

TAPE REC 150 mV/47 kilohms

Hum and noise (short circuit, A-network)

PHONO 75 dB

AUX, TUNER, TAPE PLAY

95 dB

Power requirements

Power voltage 110 ~ 120, 220 ~ 240 V
(50/60 Hz)

For U.S.A. & Canada

120 V (60 Hz)

Power consumption

180 watts Rated

250 watts Maximum

UL, CSA Model 165 watts 180 VA Rated

Dimensions

430 mm (16-15/16") W

147 mm (5-13/16") H

251 mm (9-15/16") D

Weight

6.3 kg (13.9 lbs.) net

7.2 kg (15.9 lbs.) packed

●A-80

Power output

Min. RMS, both channels driven, from 20 to 20,000 Hz,
with no more than 0.05 % total harmonic distortion
65 watts per channel into 8 ohms

Load impedance 8 ohms

Total harmonic distortion

less than 0.05 % at or below rated
min. RMS power output

Frequency response (at 1 watt)

5 to 70,000 Hz +0.5 dB, -2 dB

RIAA curve deviation (PHONO, 30 Hz to 15 kHz)

+0.6 dB, -0.6 dB

Input sensitivity and impedance (1 kHz, for rated power output)

PHONO-MM 2.5 mV/47 kilohms

(Max. input capability; 180 mV at 1 kHz, less than
0.1 % total harmonic distortion)

PHONO-MC 0.1 mV/10 ohms

AUX, TUNER, TAPE PLAY

150 mV/47 kilohms

Output level and impedance (1,000 Hz)

TAPE REC 150 mV/47 kilohms

Hum and noise (short-circuit, A-network)

PHONO-MM 80 dB

PHONO-MC 60 dB

AUX, TUNER, TAPE PLAY

95 dB

Power requirements

Power voltage 110 ~ 120, 220 ~ 240 V
(50/60 Hz)

For U.S.A. & Canada

120 V (60 Hz)

Power consumption

255 watts Rated

350 watts Maximum

UL, CSA Model 230 watts 275 VA Rated

Dimensions

430 mm (16-15/16") W

147 mm (5-13/16") H

251 mm (9-15/16") D

Weight

7.1 kg (15.7 lbs.) net

8.0 kg (17.6 lbs.) packed

*Design and specifications subject to changes without notice
for improvements.

*In order to simplify the explanation illustrations may some-
times differ from the originals.

1. BLOCK DIAGRAM

1-1. A-60

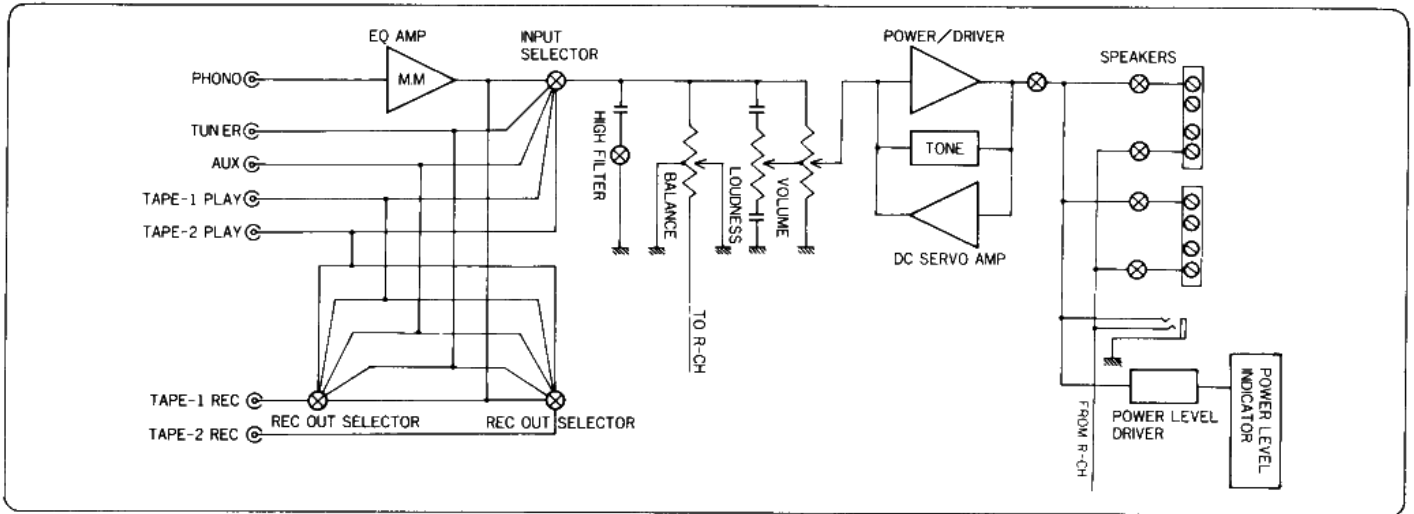

1-2. A-80

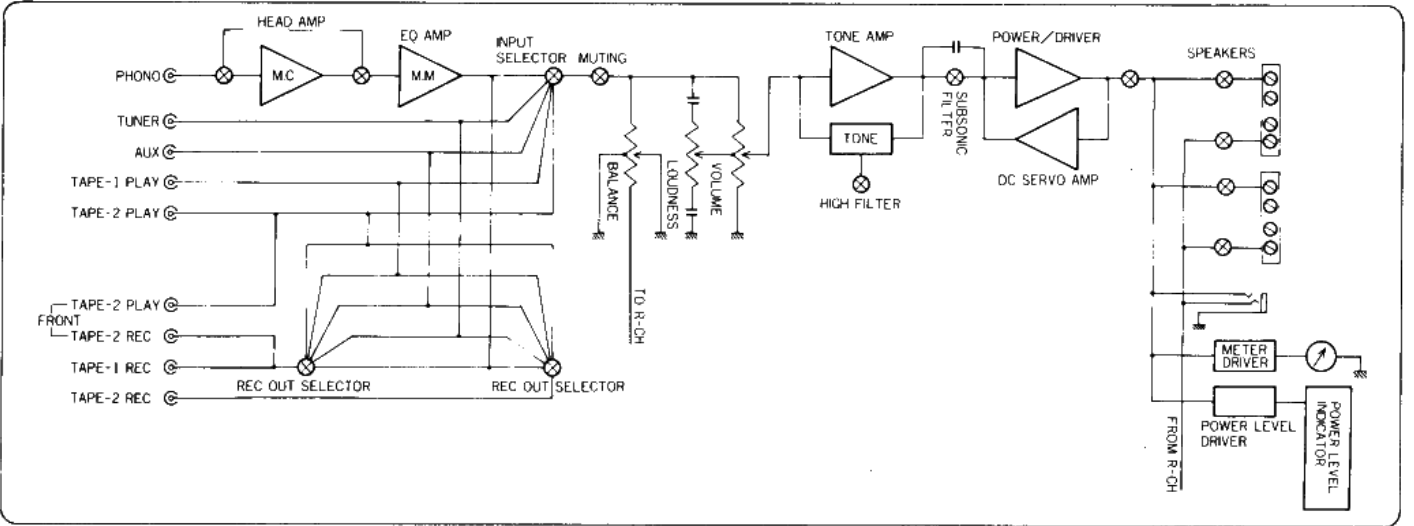

2. ADJUSTMENTS

- Notes: 1. Room Temperature 18°C ~ 28°C (65°F ~ 83°F)
 2. For this adjustment, run the unit for more than 5 minutes after the power is switched ON with its level volumes minimum.
 3. Before adjusting or confirming the bias current, avoid such a measurement that the power transistors are heated.

2-1. A-60 Bias Current Adjustment (See Top View on page 6)

STEP	SUBJECT	MEASURE OUTPUT	ADJUST	ADJUST FOR	REMARK
1.	Bias Current (L-CH) Adj.	Voltage across R71	VR01 on F-3159	DC 1.5 mV	Before turning ON power switch, turn VR01, VR02 fully counterclockwise.
2.	Bias Current (R-CH) Adj.	Voltage across R72	VR02 on F-3159	DC 1.5 mV	In this adjustment, the bias current is converted into the voltage.

2-2. A-80 Bias Current Adjustment (See Top View on page 7)

STEP	SUBJECT	MEASURE OUTPUT	ADJUST	ADJUST FOR	REMARK
1.	Bias Current (L-CH) Adj.	Voltage across R87	VR01 on F-3144	DC 1.5 mV	Before turning ON power switch, turn VR01, VR02 fully counterclockwise.
2.	Bias Current (R-CH) Adj.	Voltage across R88	VR02 on F-3144	DC 1.5 mV	In this adjustment, the bias current is converted into the voltage.

A

B

C

D

E

5-2. A-80

HEAD AMP (MC,MM)

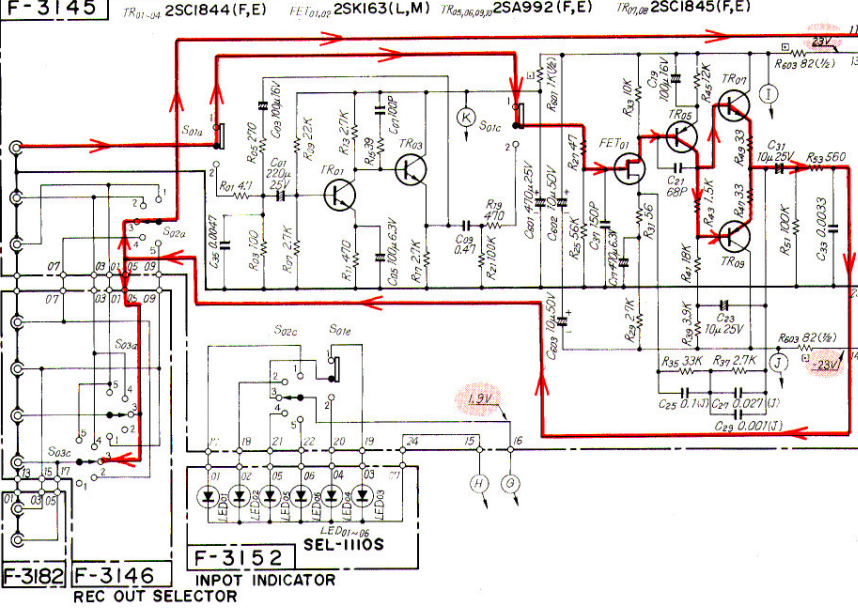

CONTROL AMP, POWER AMP, POWER SUPPLY

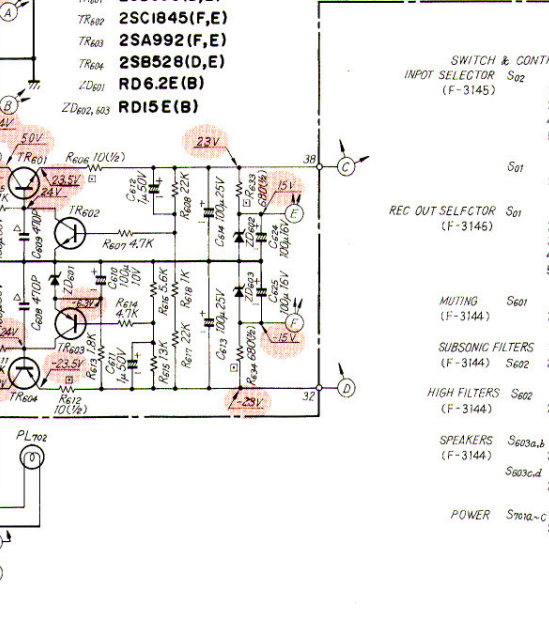
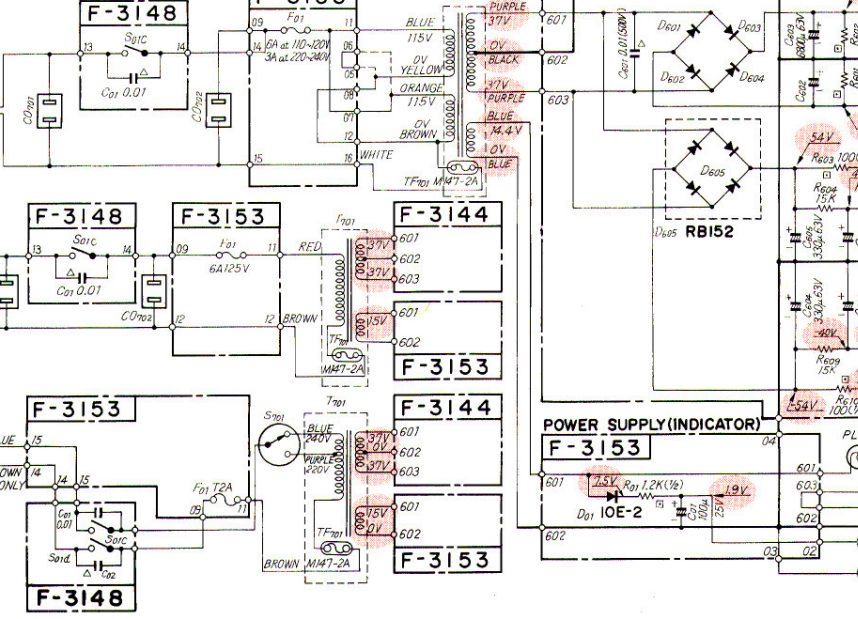
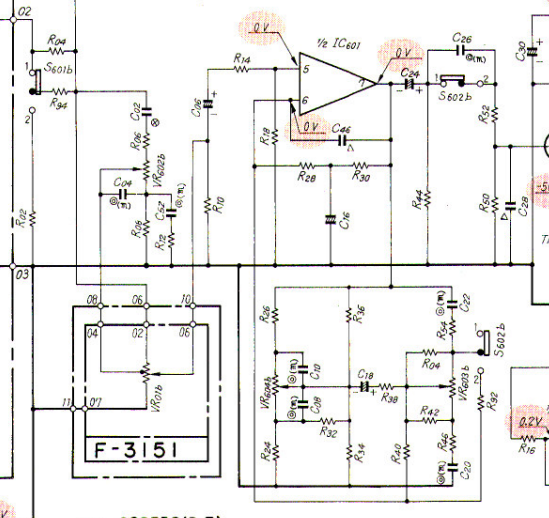
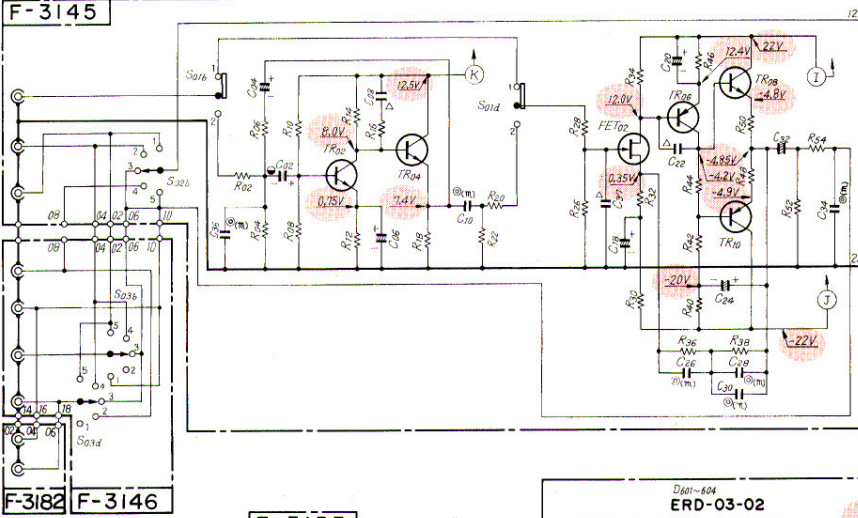
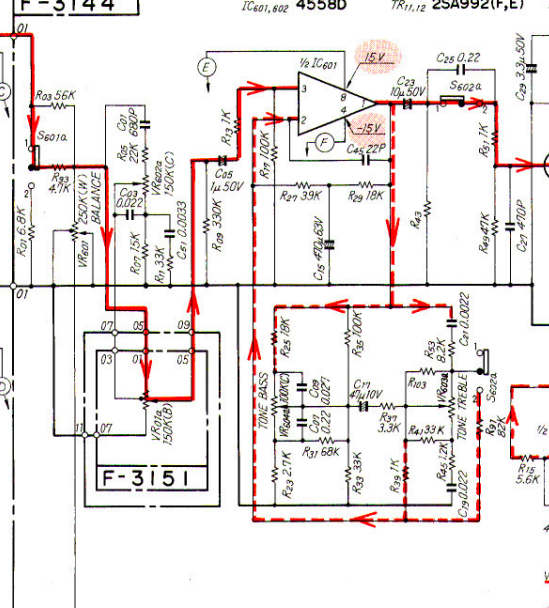

* Design and specifications subject to change without notice for improvement.
 * La présentation et les spécifications sont susceptibles d'être modifiées sans préavis par suites d'améliorations éventuelles.
 * Änderungen, die dem technischen Fortschritt dienen, bleiben vorbehalten.

MP, POWER SUPPLY

IC_{601,602} 4558D TR_{1,12} 2SA992(F,E) TR_{15,16,19,20} 2SC1845(F,E) TR_{13,14} 2SA798(F,G) TR_{17,18} 2SC1904(B,V) TR_{21,22} 2SD358(D,E) TR_{23,24} 2SB528(D,E) TR_{25,26} 2SC2579(O,Y) TR_{21,28} 2SA1104(O,Y)

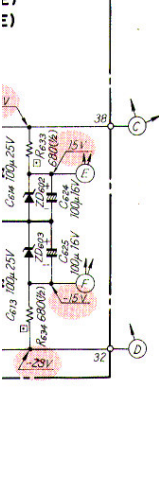
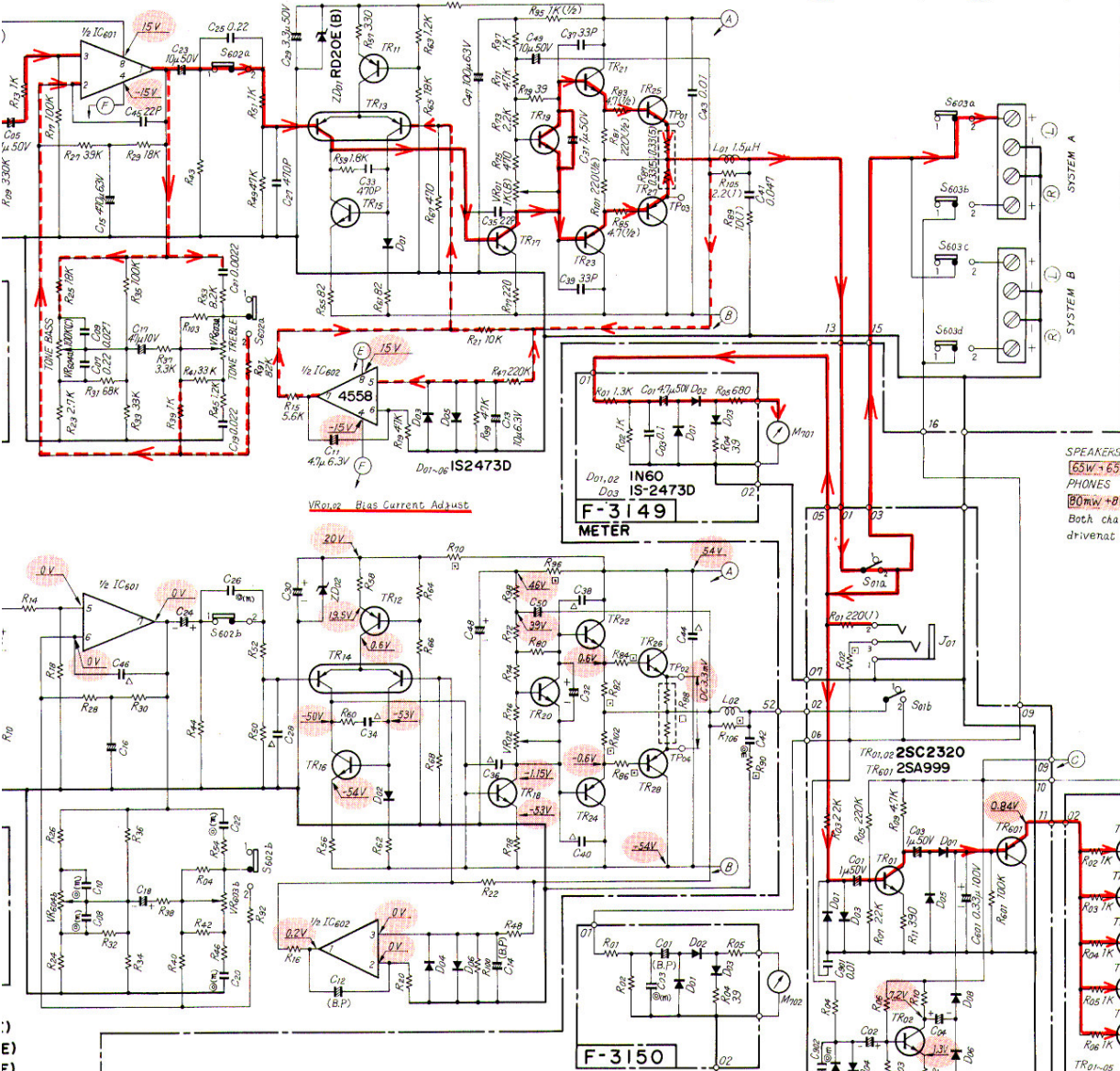

- SWITCH & CONTROLS**
- INPUT SELECTOR (F-3145) S₀₂
- AUX
 - TUNER
 - PHONO
 - TAPE 1
 - TAPE 2
- MUTING (F-3144) S₀₁
- MM
 - MC
- REC OUT SELECTOR (F-3146) S₀₁
- TAPE 2 > 1
 - TAPE 1 > 2
 - PHONO
 - TUNER
 - AUX
- MUTING (F-3144) S₀₂
- OFF
 - 20dB
- SUBSONIC FILTERS (F-3144) S₀₂
- OFF
 - 16Hz
- HIGH FILTERS (F-3144) S₀₂
- OFF
 - ON
- SPEAKERS (F-3144) S_{03a,b}
- OFF
 - A
- S_{03c,d}
- OFF
 - B
- POWER (F-3144) S_{01a-c}
- OFF
 - ON

- SYMBOL**
- △ Ceramic
 - Low-Leak Electrolytic
 - (B.P) Bi-Polar Electrolytic
 - ⊖ Polystyrene
 - ⊙ Mylar
 - Cement Resistor
 - ▢ Non-Inflammable Resistor
- RESISTORS**
- Are in ohms, 1/4 Watts, ±5% Tolerance Unless Otherwise Noted. K:KΩ, M:MΩ
- CAPACITORS**
- Are in μF, Unless Otherwise Noted. P: pF
- TOLERANCE**
- J: ±5%, G: ±7%, F: ±1%
- Each DC Voltage shows the nominal value in volts at no input signal
- BASS** VR_{604 a,b} F-3144
- TREBLE** VR_{603 a,b} F-3144
- LOUDNESS** VR_{602 a,b} F-3144
- BALANCE** VR₆₀₁ F-3144
- VOLUME** VR_{01 a,b} F-3151

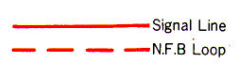

SPEAKERS
 65W + 65W / 8 Ω
PHONES
 80mW + 80mW / 8 Ω
 Both channel driven at 1000Hz.

- 2SA992
- 2SA999
- 2SC1844
- 2SC1845
- 2SC2320
- 2SK163
- 2SC1904
- NJM4558D
- 2SA1104
- 2SC2579
- 2SB528
- 2SD358
- 2SA798
- IS2473D
- ERD03 02H
- IN 60
- RD6 2E-B
- RD15E-B
- RD20E-B
- RB-152
- 10E2

1

2

3

4

5