

SERVICE MANUAL

INTEGRATED SERVO AMPLIFIER

SANSUI A-M900

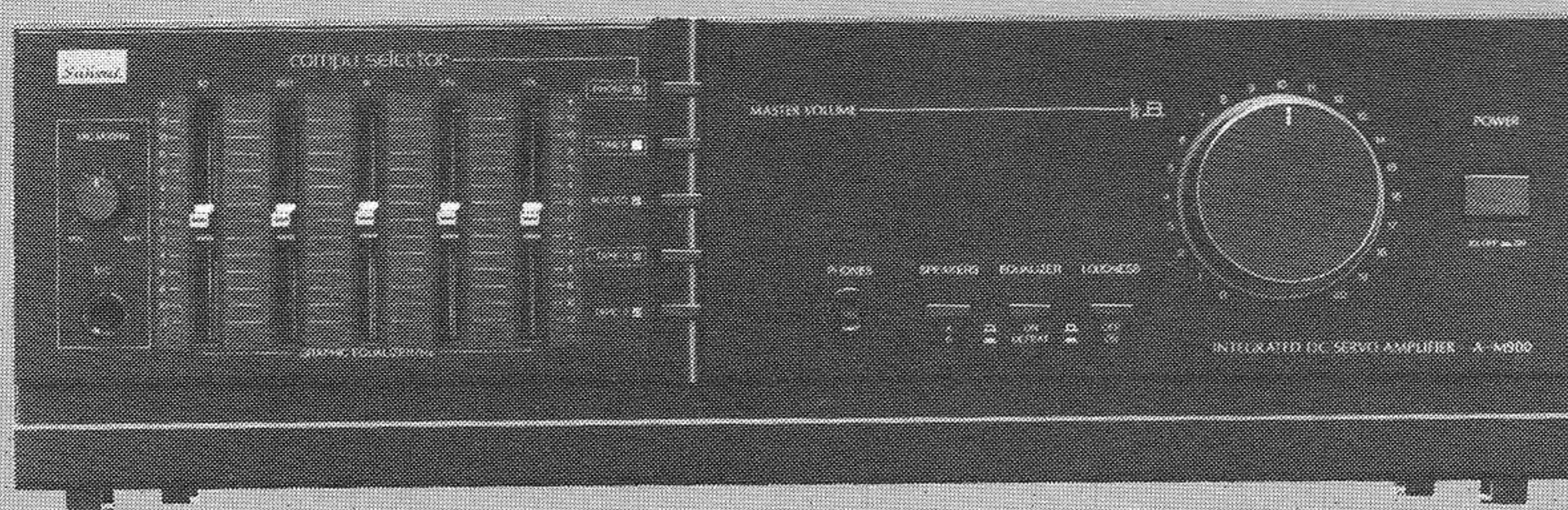

NOTE

A-M900 is additional model which external appearances are different from those of A-M99.

This manual contains **OTHER PARTS LIST**, **PACKING LIST** and **ACCESSORY LIST** in which changed parts are printed with bold-face.

For other parts list, refer to A-M99 service manual previously issued.

•SPECIFICATIONS

Power output

Min. RMS, both channels driven, from 20 to 20,000 Hz with no more than 0.07% total harmonic distortion.

70 watts per channel into 8 ohms.

Load impedance..... 8 ohms

Total harmonic distortion

..... less than 0.07% at or below rated min. RMS power output

Frequency response (at 1 watt)

..... 10 to 60,000 Hz/ +0.5 dB, -2 dB

RIAA curve deviation (PHONO, 30 Hz to 20 kHz)

..... +0.5 dB, -0.5 dB

Input sensitivity and impedance

(1 kHz, for rated power output)

PHONO..... 2.5 mV/47 kilohms

(Max. input capability: 150 mV at 1 kHz, less than 0.5% total harmonic distortion)

TUNER, TAPE PLAY (1, 2), AUX/CD

..... 150 mV/47 kilohms

MIC..... 0.5 mV/10 kilohms

Output level (1 kHz)

TAPE REC..... 150 mV into 47 kilohms

Signal to noise ratio (short-circuit, A-network)

PHONO..... 72 dB

TUNER, TAPE PLAY (1, 2), AUX/CD

..... 100 dB

Power requirements

Power voltage..... 120/220/240 V (50/60 Hz)

For U.S.A. & Canada

..... 120 V (60 Hz)

Power consumption.... 230 watts 280 VA Rated

350 watts Maximum

Dimensions..... 345 mm (13-5/8") W

111 mm (4-3/8") H

234 mm (9-1/4") D

Weight..... 5.4 kg (11.9 lbs.) net

6.2 kg (13.7 lbs.) packed

* Design and specifications subject to changes without notice for improvements.

* Due to local laws and regulations, this unit sold in some areas are not equipped with variable voltage selectors

Sansui

SANSUI ELECTRIC CO., LTD.

1. OTHER PARTS

•Front View

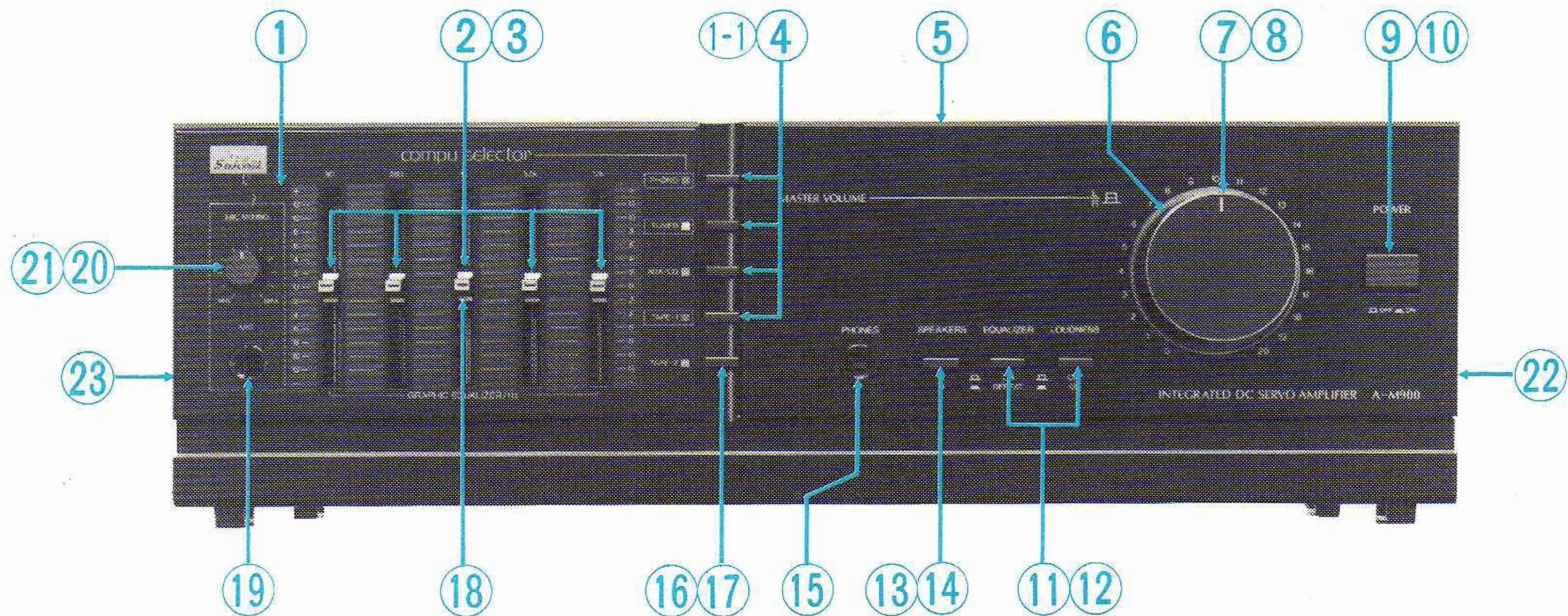

Parts List

Parts No.	Stock No.	Description
1	47732400	Front Panel Ass'y (with Push Knob 1-1, PHONO•TUNER•AUX/DA•TAPE)
2	47744200	Slide Knob, GRAPHIC EQUALIZER
3	46834600	250kΩ × 2 Slide V.R., GRAPHIC EQUALIZER
4	46396700	Push SW., PHONO•TUNER•AUX/DA•TAPE-1
5	47560400	Bonnet (XX,UL,CSA)
	47560500	Bonnet (EU,BS,AS)
6	47557200	Knob, MASTER VOLUME (Right)
7	47557100	Knob, MASTER VOLUME (Left)
8	46555900	150kΩ × 2 V.R., MASTER VOLUME
9	47157800	Push Knob, POWER
⚠ 10	46364300	Push SW., POWER
11	47560300	Push Knob, LOUDNESS•EQUALIZER

Parts No.	Stock No.	Description
12	46556400	Push SW., LOUDNESS•EQUALIZER
13	47538200	Push Knob, SPEAKERS
14	46361000	Push SW., SPEAKERS
15	24306200	Jack, PHONES
16	47560200	Push Knob, TAPE-2
17	46556300	Push SW., TAPE-2
18	46176900	L.E.D TLS-123 (Red), GRAPHIC EQUALIZER
	or 46470200	L.E.D SEL2210S (Red), GRAPHIC EQUALIZER
19	46838700	Jack, MIC
20	07895410	Knob, MIC
21	46834700	20kΩ (A) V.R., MIC
22	47491020	Side Panel (Right)
23	47490910	Side Panel (Left)

2. PACKING LIST

Parts No.	Stock No.	Description
1	47859000	Vinyl Cover
2	47187650	Styrofoam Packing
3	47937700	Carton Case

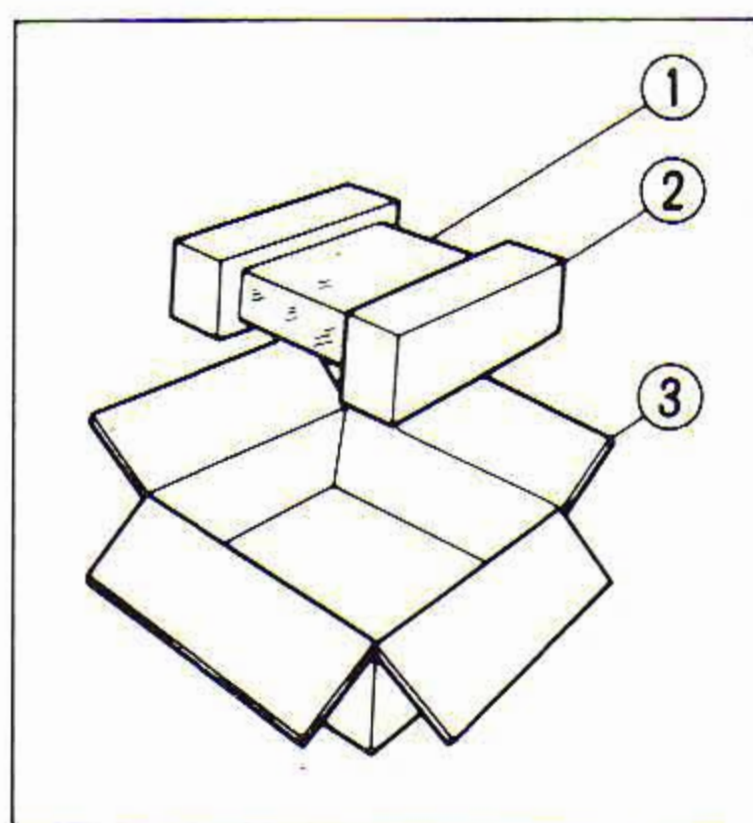

3. ACCESSORY LIST

Stock No.	Description
46979600	Operating Instruction
46983300	Operating Sheet



SANSUI ELECTRIC CO., LTD.:
 SANSUI ELECTRONICS CORPORATION:
 SANSUI ELECTRONICS (U.K.) LTD.:
 SANSUI ELECTRONICS G.M.B.H.:

14-1, Izumi 2-chome, Sugunami-ku, Tokyo 168 Japan
 PHONE: (03) 324-8891/TELEX: 232-2076 (International Division)
 1250 Valley Brook Ave. Lyndhurst, N.J. 07071 U.S.A.
 17150 South Margay Ave. Carson, California 90746 U.S.A.
 3036 Koapaka Street. Honolulu, Hawaii 96819 U.S.A.
 Unit 10A, Lyon Industrial Estate, Rockware Avenue, Greenford, Middx UB6, OAA, England
 Pau Ehrich Strasse 8, 6074 Rödermark 2, West Germany

SERVICE MANUAL

INTEGRATED SERVO AMPLIFIER

SANSUI A-M99

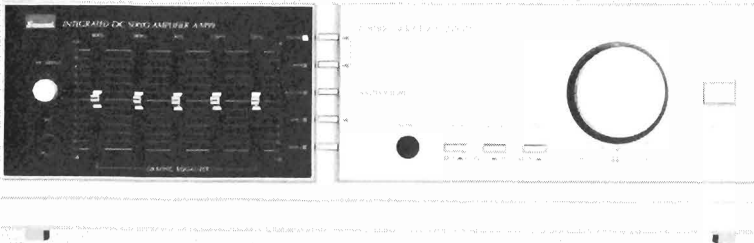

CAUTION

1. Parts identified by the \triangle symbol on the schematic diagram and the parts list are critical for safety. Use only replacement parts that have critical characteristics recommended by the manufacturer.
2. Make leakage-current or resistance measurements to determine that exposed parts are acceptably insulated from the supply circuit before returning the appliance to the customer.

Sansui

SANSUI ELECTRIC CO., LTD.

•Specifications

Power output

Min. RMS, both channels driven, from 20 to 20,000 Hz with no more than 0.07% total harmonic distortion.

70 watts per channel into 8 ohms.

Load impedance..... 8 ohms

Total harmonic distortion

..... less than 0.07% at or below rated min. RMS power output

Frequency response (at 1 watt)

..... 10 to 60,000 Hz/+0.5 dB, -2 dB

RIAA curve deviation (PHONO, 30 Hz to 20 kHz)

..... +0.5 dB, -0.5 dB

Input sensitivity and impedance (1 kHz, for rated power output)

PHONO..... 2.5 mV/47 kilohms

(Max. input capability: 150 mV at 1 kHz, less than 0.5% total harmonic distortion)

TUNER, TAPE PLAY (1, 2), AUX/DA

..... 150 mV/47 kilohms

MIC 0.5 mV/10 kilohms

Output level (1 kHz)

TAPE REC..... 150 mV into 47 kilohms

Signal to noise ratio (short-circuit, Anetwork)

PHONO..... 72 dB

TUNER, TAPE PLAY (1, 2), AUX/DA

..... 100 dB

Power requirements

Power voltage..... 120/220/240 V (50/60 Hz)

For U.S.A. & Canada 120 V (60Hz)

Power consumption.... 230 watts 280 VA Rated

350 watts Maximum

Dimensions..... 345 mm (13-5/8") W

111 mm (4-3/8") H

234 mm (9-1/4") D

Weight..... 5.4 kg (119 lbs.) net

6.2 kg (137 lbs.) packed

* Design and specifications subject to change without notice for improvements.

CAUTION

1. The symbols, UL, CSA, BS, UK, EU, AS and XX on the parts list and the schematic diagram mean followings respectively.
 - UL..... Manufactured for U.S.A market.
(Underwriters Laboratories approved model.)
 - CSA Manufactured for Canadian market.
 - BS, UK Manufactured for United Kingdom market.
 - EU Manufactured for European market.
 - AS..... Manufactured for Australian market.
 - XX..... Standard Version.
 - NON MARK Common Parts.

2. Some printed circuit boards are not supplied as the assembled. To separate these in this service manual, the stock No's are not indicated at the ends of the board names. However, the individual parts on the circuit boards are provided by orders.

3. Since some of capacitors and resistors are omitted from parts lists in this service manual, refer to the Common Parts List for capacitors & resistors, which was issued on February 1983.

4. Abbreviations in this service manual are as follows.

•Abbreviations List

C.R. : Carbon Resistor	E.B. : Bi-Polar Electrolytic Capacitor
S.R. : Solid Resistor	E.B.L. : Low Leak Bi-Polar Electrolytic Capacitor
Ce.R. : Cement Resistor	Ta.C. : Tantalum Capacitor
M.R. : Metal Film Resistor	F.C. : Film Capacitor
F.R. : Fusing Resistor	M.P. : Metalized Paper Capacitor
N.I.R. : Non-Inflammable Resistor	P.C. : Polystyrene Capacitor
A.R. : Array Resistor	G.C. : Gimmic Capacitor
C.C. : Ceramic Capacitor	A.C. : Array Capacitor
C.T. : Ceramic Capacitor, Temoerature Compensation	V.R. : Variable Resistor
E.C. : Electrolytic Capacitor	S.V.R. : Semi Variable Resistor
E.L. : Low Leak Electrolytic Capacitor	SW. : Switch

1. BLOCK DIAGRAM

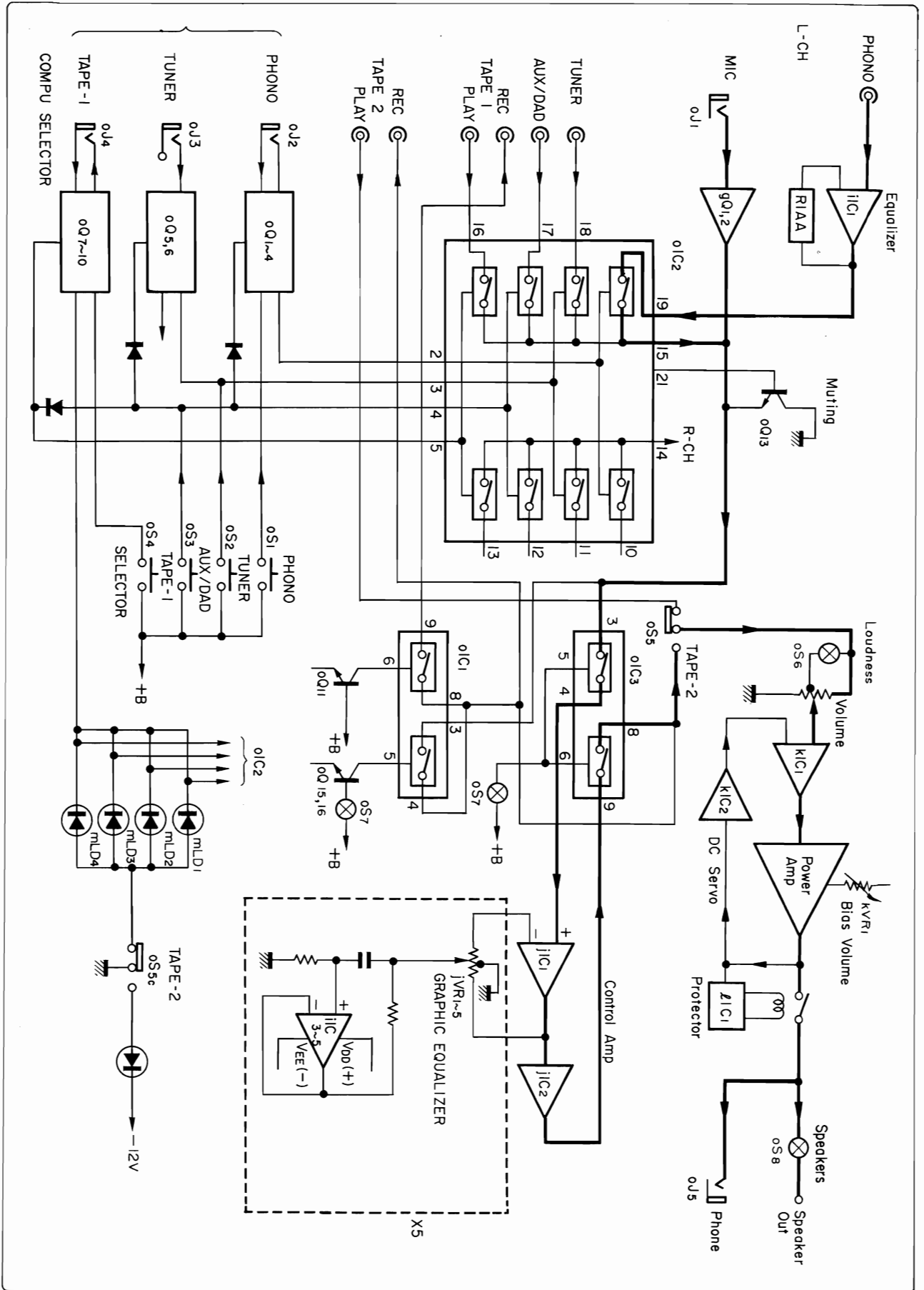

2. PARTS LOCATION & PARTS LIST

2-1. F-4387 Power Amp. Circuit Board (Stock No. 00769501)

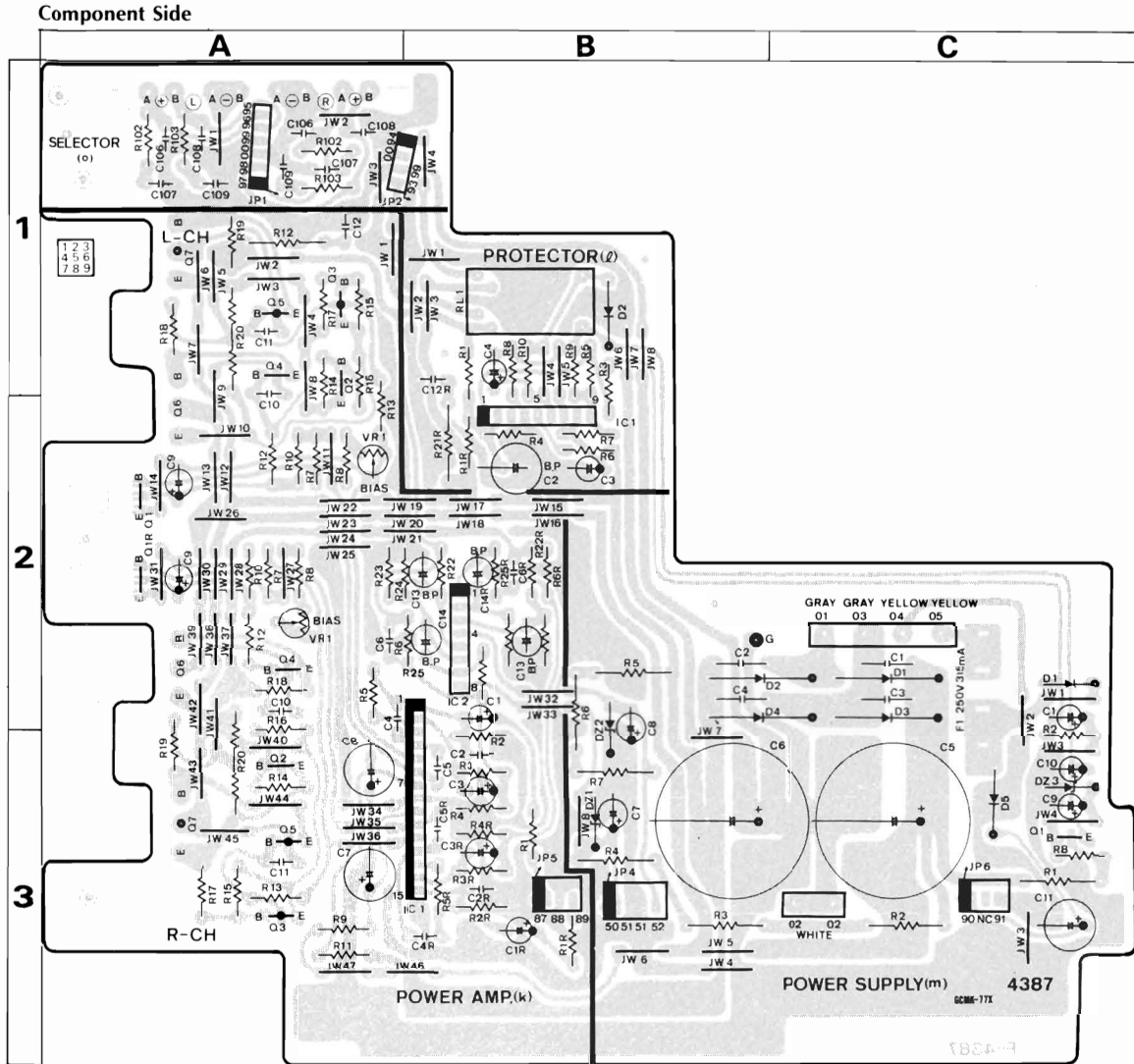

Parts List

Parts No.	Stock No.	Description
• Transistor		
↑ KQ1	03067401	2SC1845
KQ2	46367101	2SC2603
	or 46367301	2SC2458
KQ3	46367001	2SA1115
	or 46367201	2SA1048
↑ KQ4	07206401	2SD600K
↑ KQ5	07206301	2SB631K
↑ KQ6	46085301	2SC2581
↑ KQ7	46085401	2SA1106
• IC		
KIC1	46921800	STK3082-2A
KIC2	46147700	M5218L
↑ KR9	00135300	47Ω 1/2W N.I.R.
↑ KR11	00130900	100Ω 1/2W N.I.R.
↑ KR12	00135300	47Ω 1/2W N.I.R.
↑ KR13	00135300	47Ω 1/2W N.I.R.
↑ KR14	00130900	100Ω 1/2W N.I.R.
↑ KR15	00130900	100Ω 1/2W N.I.R.
↑ KR16	00133000	220Ω 1/2W N.I.R.
↑ KR17	00133000	220Ω 1/2W N.I.R.
↑ KR18	00132000	150Ω 1/2W N.I.R.
↑ KR19	00132000	150Ω 1/2W N.I.R.
↑ KR20	00091700	0.33Ω × 2 5W, Ce.R.
↑ KR21	46241200	10Ω 1W N.I.R.

Parts List

Parts No.	Stock No.	Description
KC12	08451000	10μF 16V E.B.
KC13	08450900	4.7μF 16V E.B.
kVR1	46633700	1kΩ S.V.R., Bias Volume
• IC		
IIC1	46207600	TA7317P
• Diode		
ID1	03117600	1S2473T77
	or 46086000	1S1588TP-3
ID2	03117700	10E-2
IC2	08460200	220μF 6.3V E.B.
IRL1	46254900	Relay AP24D2
• Transistor		
↑ mQ1	03067401	2SC1845
• Diode		
↑ mD1	03115300	30D2
↑ mD2	03115300	30D2
↑ mD3	03115300	30D2
↑ mD4	03115300	30D2
↑ mD5	03117700	10E-2

Parts List		
Parts No.	Stock No.	Description
•Zener Diode		
mDZ1	03170300	RD12FB
mDZ2	03170300	RD12FB
mDZ3	46116000	05Z24-Y
mR1	46243400	680Ω 1W N.I.R.
mR2	46624700	220Ω 2W N.I.R.
mR3	46624700	220Ω 2W N.I.R.
mR4	46624700	220Ω 2W N.I.R.
mR5	46624700	220Ω 2W N.I.R.
mR6	46624700	220Ω 2W N.I.R.
mR7	46624700	220Ω 2W N.I.R.

Parts List		
Parts No.	Stock No.	Description
mC1	08680400	0.01μF 500V C.C.
mC2	08680400	0.01μF 500V C.C.
mC3	08680400	0.01μF 500V C.C.
mC4	08680400	0.01μF 500V C.C.
mC5	08301800	6800μF 63V E.C.
mC6	08301800	6800μF 63V E.C.
mF1	46201000	Fuse 315 mA 250V (XX, UL, CSA)
	07184200	Fuse 315 mA 250V (EU, BS, AS)
	46364100	8P Speaker Terminal

2-2. F-4383 Control & Compu Selector Circuit Board (Stock No. 00769101)

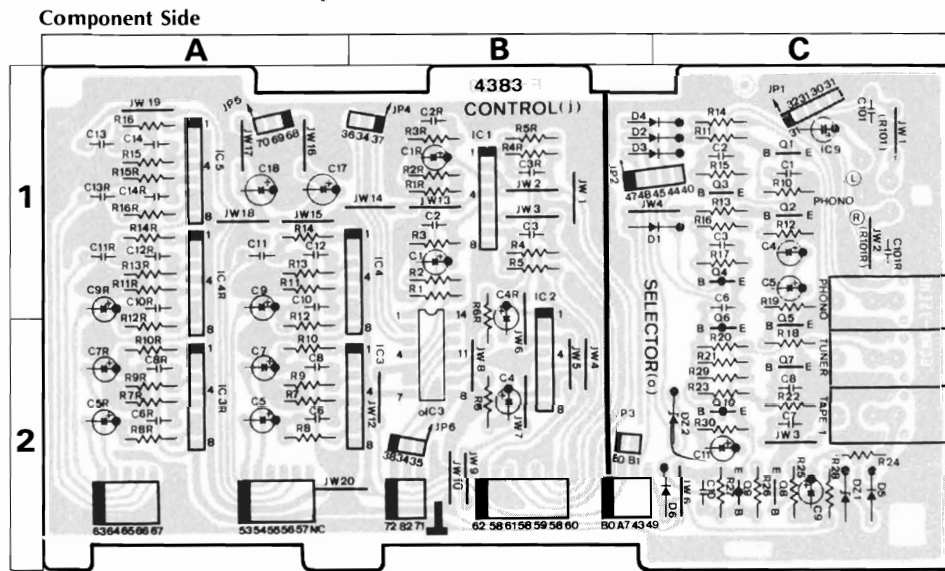

Parts List		
Parts No.	Stock No.	Description
•IC		
jIC1	46147700	M5218L
jIC2	46147700	M5218L
jIC3	46147700	M5218L
jIC4	46147700	M5218L
jIC5	46147700	M5218L
•Transistor		
oQ1	46367101	2SC2603
	or 46367301	2SC2458
oQ2	46367101	2SC2603
	or 46367301	2SC2458
oQ3	46367101	2SC2603
	or 46367301	2SC2458
oQ4	46367001	2SA1115
	or 46367201	2SA1048
oQ5	46367101	2SC2603
	or 46367301	2SC2458
oQ6	46367001	2SA1115
	or 46367201	2SA1048
oQ7	46367101	2SC2603
	or 46367301	2SC2458
oQ8	46367101	2SC2603
	or 46367301	2SC2458
oQ9	46367001	2SA1115
	or 46367201	2SA1048
oQ10	46367001	2SA1115
	or 46367201	2SA1048

Parts List		
Parts No.	Stock No.	Description
•IC		
oIC3	46255000	LC4066BH
•Diode		
oD1	03117600	1S2473T77
	or 46086000	1S1588TP-3
oD2	03117600	1S2473T77
	or 46086000	1S1588TP-3
oD3	03117600	1S2473T77
	or 46086000	1S1588TP-3
oD4	03117600	1S2473T77
	or 46086000	1S1588TP-3
oD5	03117600	1S2473T77
	or 46086000	1S1588TP-3
oD6	03117600	1S2473T77
	or 46086000	1S1588TP-3
•Zener Diode		
oDZ1	46111200	05Z 5.1-Y
oDZ2	46114200	05Z13-Y
oJ2	46547200	Mini Jack, PHONO
oJ3	46547200	Mini Jack, TUNER
oJ4	46547200	Mini Jack, TAPE-1
	46438100	2P Input Terminal, PHONO

2-3. F-4382 Input Selector SW & MIC AMP. Circuit Board (Stock No. 00769001)

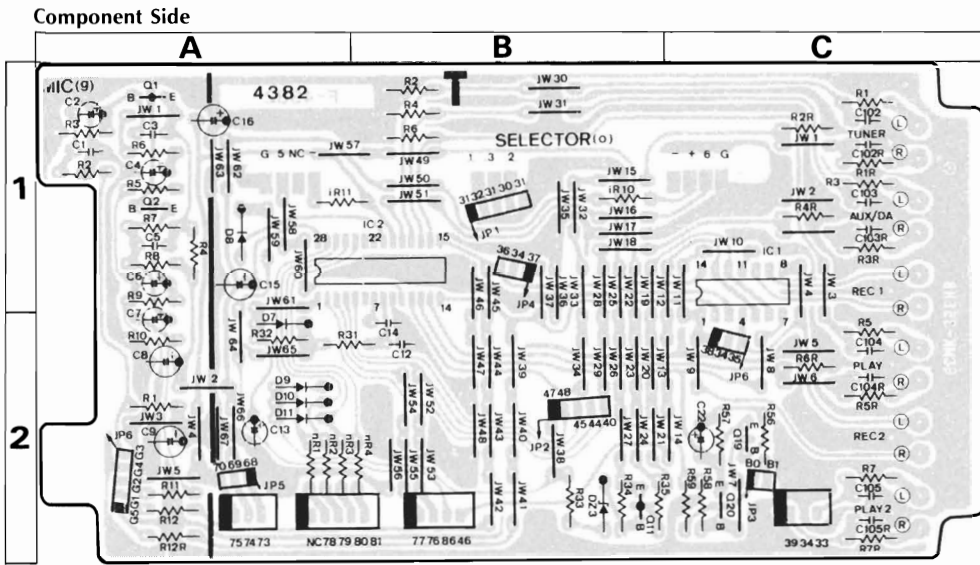

Parts No.	Stock No.	Description
• Transistor		
gQ1	46581601	2SA992
gQ2	46577801	2SC2320L
oQ11	46367201 or 46367001	2SA1048 2SA1115
• IC		
oIC1	46255000	LC4066BH
oIC2	46394800	LC7815H

Parts No.	Stock No.	Description
• Diode		
oD7	03117600 or 46086000	1S2473T77 1S1588TP-3
oD8	03117600 or 46086000	1S2473T77 1S1588TP-3
oD9	03117600 or 46086000	1S2473T77 1S1588TP-3
oD10	03117600 or 46086000	1S2473T77 1S1588TP-3
oD11	03117600 or 46086000	1S2473T77 1S1588TP-3
oD23	46114200	05Z13-Y7
	46363900	6P Input Terminal

2-4. F-4386 Function Switch Circuit Board (Stock No. 00769401)

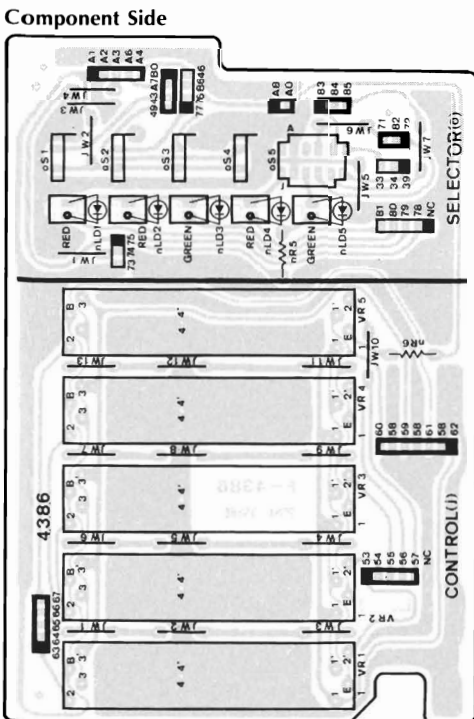

Parts No.	Stock No.	Description
jVR1	46834600	250kΩ Slide V.R., 80Hz
jVR2	46834600	250kΩ Slide V.R., 280Hz
jVR3	46834600	250kΩ Slide V.R., 1 kHz
jVR4	46834600	250kΩ Slide V.R., 3.5 kHz
jVR5	46834600	250kΩ Slide V.R., 12 kHz
• LED		
nLD1	46176900 or 46470200	TLS-123 SEL2210S
nLD2	46176900 or 46470200	TLS-123 SEL2210S
nLD3	07250900 46470300	TLG123A SEL2410E
nLD4	46176900 or 46470200	TLS-123 SEL2210S
nLD5	07250900 or 46470300	TLG-123A SEL2410E
oS1	46396700	Push SW., PHONO
oS2	46396700	Push SW., TUNER
oS3	46396700	Push SW., AUX/PAD
oS4	46396700	Push SW., TAPE-1
oS5	46556300	Push SW., TAPE-2

2-5. F-3725 EQ. Amp. Circuit Board

Component Side

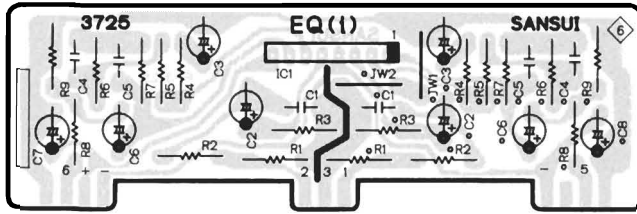

Parts List < F-3725 >

Parts No.	Stock No.	Description
• IC		
ic1	46078900	M5218L

Parts List < F-4385 >

Parts No.	Stock No.	Description
jVR6	46555900	150kΩ 3B x 2, VOLUME
• Transistor		
oQ12	46367301	2SC2458
	or 46367101	2SC2603
oQ13	46367201	2SA1048
	or 46367001	2SA1115
oQ14	46367201	2SA1048
	or 46367001	2SA1115
oQ15	46367201	2SA1048
	or 46367001	2SA1115
oQ16	46367201	2SA1048
	or 46367001	2SA1115
oQ17	46367201	2SA1048
	or 46367001	2SA1115
oQ18	46367201	2SA1048
	or 46367000	2SA1115

2-6. F-4385 Master Volume Circuit Board

Component Side

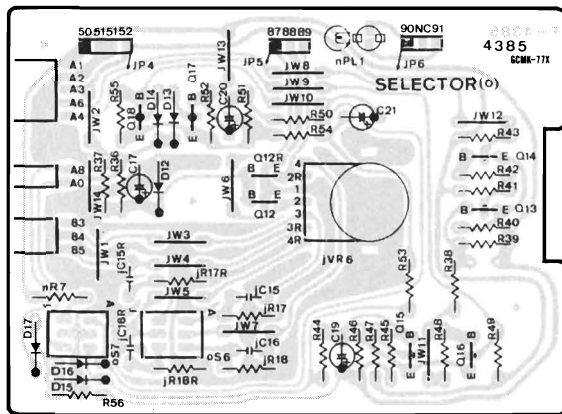

• Diode		
oD12	03117600	1S2473T77
	or 46086000	1S1588TP-3
oD13	03117600	1S1473T77
	or 46086000	1S1588TP-3
oD14	03117600	1S2473T77
	or 46086000	1S1588TP-3
oD15	03117600	1S2473T77
	or 46086000	1S1588TP-3
oD16	03117600	1S2473T77
	or 46086000	1S1588TP-3
oD17	03117600	1S2473T77
	or 46086000	1S1588TP-3
oS6	46556400	Push SW, Loudness
oS7	46556400	Push SW, GRAPHIC EQUALIZER

2-7. F-4389 Voltage Selector Circuit Board

Component Side

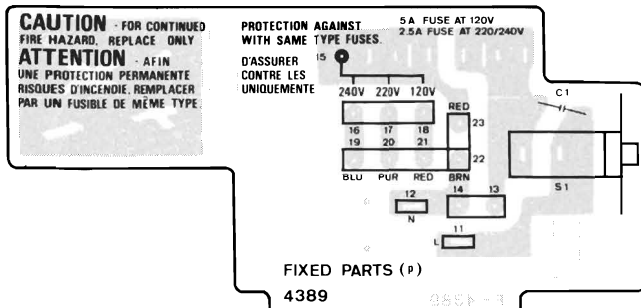

Parts List < F-4389 >

Parts No.	Stock No.	Description
pC1	46425800	0.01μF 400V C.C.
pF1	07188700	Power Fuse 2.5A 250V (XX)
	07189100	Power Fuse 5A 250V (JL, CS, XX)
pS1	46364300	Push SW., POWER

2-8. F-4384 MIC Volume Circuit Board

Component Side

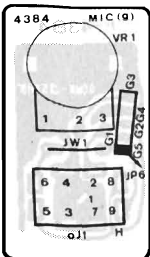

Parts List

Parts No.	Stock No.	Description
gVR1	46834700	20kΩ, V.R., MIC Level
oJ1	46838700	MIC Jack

2-9. F-4388 Head Phone Jack Circuit Board

Component Side

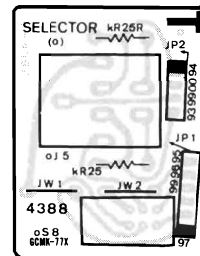

Parts List

Parts No.	Stock No.	Description
oS8	46361000	Push SW., SPEAKERS
oJ5	24306200	Head Phone Jack

3. OTHER PARTS

3-1. Front View

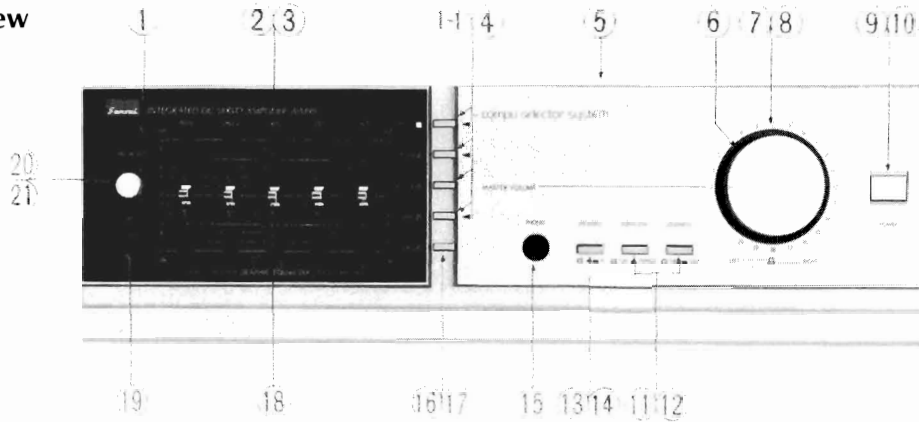

3-2. Top View

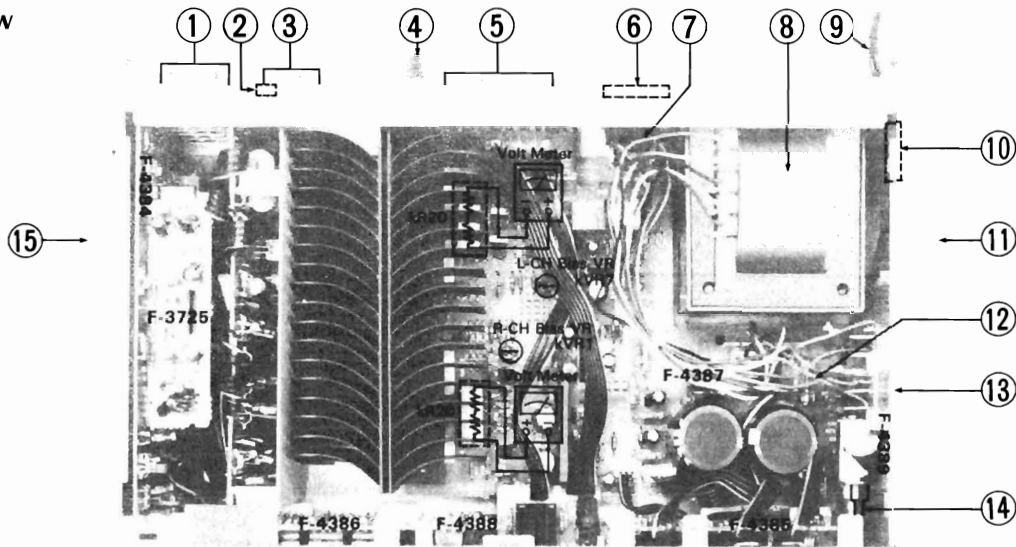

Parts List < Front View >

Parts No.	Stock No.	Description
1	47355700	Front Panel Ass'y (with Push Knob 1-1 , PHONO·TUNER·AUX/DA·TAPE)
2	47380300	Slide Knob, GRAPHIC EQUALIZER
3	46834600	250kΩ×2 Slide V.R., GRAPHIC EQUALIZER
4	46396700	Push SW., PHONO·TUNER·AUX/DA·TAPE-1
5	47464900	Bonnet (XX, UL, CS)
	47484800	Bonnet (EU, BS, AS)
6	47355500	Knob, MASTER VOLUME (Right)
7	47355400	Knob, MASTER VOLUME (Left)
8	46555900	150kΩ(B)×2 V.R., MASTER VOLUME
9	47157800	Push Knob, POWER
10	46364300	Push SW., POWER
11	47351500	Push Knob, LOUDNESS·EQUALIZER
12	46556400	Push SW., LOUDNESS·EQUALIZER
13	47318300	Push Knob, SPEAKERS
14	46361000	Push SW., SPEAKERS
15	24306200	Jack, PHONES
16	47351400	Push Knob, TAPE-2
17	46556300	Push SW., TAPE-2
18	46176900	L.E.D TLS-123 (Red), GRAPHIC EQUALIZER
	or 46470200	L.E.D SEL2210S (Red),GRAPHIC EQUALIZER
19	46838700	Jack, MIC
20	47395500	Knob, MIC
21	46834700	20kΩ(A) V.R., MIC

Parts List < Top View >

Parts No.	Stock No.	Description
1	46363900	6P Input/Output Terminal Board , TUNER·AUX/DA·TAPE-1·TAPE-2
2	46547200	Mini Jack, COMPU SELECTOR
3	46438100	2P Input Terminal Board, PHONO
4	22301510	Ground Terminal
5	46364100	8P Output Terminal Board, SPEAKERS
6	07204700	Slide SW., Voltage Selector (EU·BS·AS)
7	46365000	AC OUTLETS (XX·UL CSA)
	46161000	AC OUTLETS (EU)
	46364800	AC OUTLETS (BS)
	46580600	AC OUTLET (AS)
8	15014301	Power Transformer (XX)
	15014302	Power Transformer (UL·CSA)
	15014305	Power Transformer (EU·BS·AS)
9	38005700	Power Supply Cord (XX·UL)
	46407700	Power Supply Cord (CSA)
	38004500	Power Supply Cord (EU)
	38004300	Power Supply Cord (BS)
	07204200	Power Supply Cord (AS)
10	47157300	Cord Cover
11	47174920	Side Panel (Right)
12	46201000	Fuse 315mA 250V (XX·UL·CSA)
	07184200	Fuse 315mA 250V (EU·BS·AS)
13	07189100	Fuse 5.0A 250V <120V> (XX·UL·CSA)
	07188700	Fuse 2.5A 250V <220/240V> (XX)
	07185000	Fuse 2.0A 250V (EU·BS·AS)
14	47351200	Joint Shaft
15	47174800	Side Panel (Left)

4. SCHEMATIC DIAGRAM 4-1. Pre Amp. Section

*Design and specifications subject to change without notice for improvement.
 *La présentation et les spécifications sont susceptibles d'être modifiées sans préavis par suites d'améliorations éventuelles.
 *Änderungen, die dem technischen Fortschritt dienen, bleiben vorbehalten.

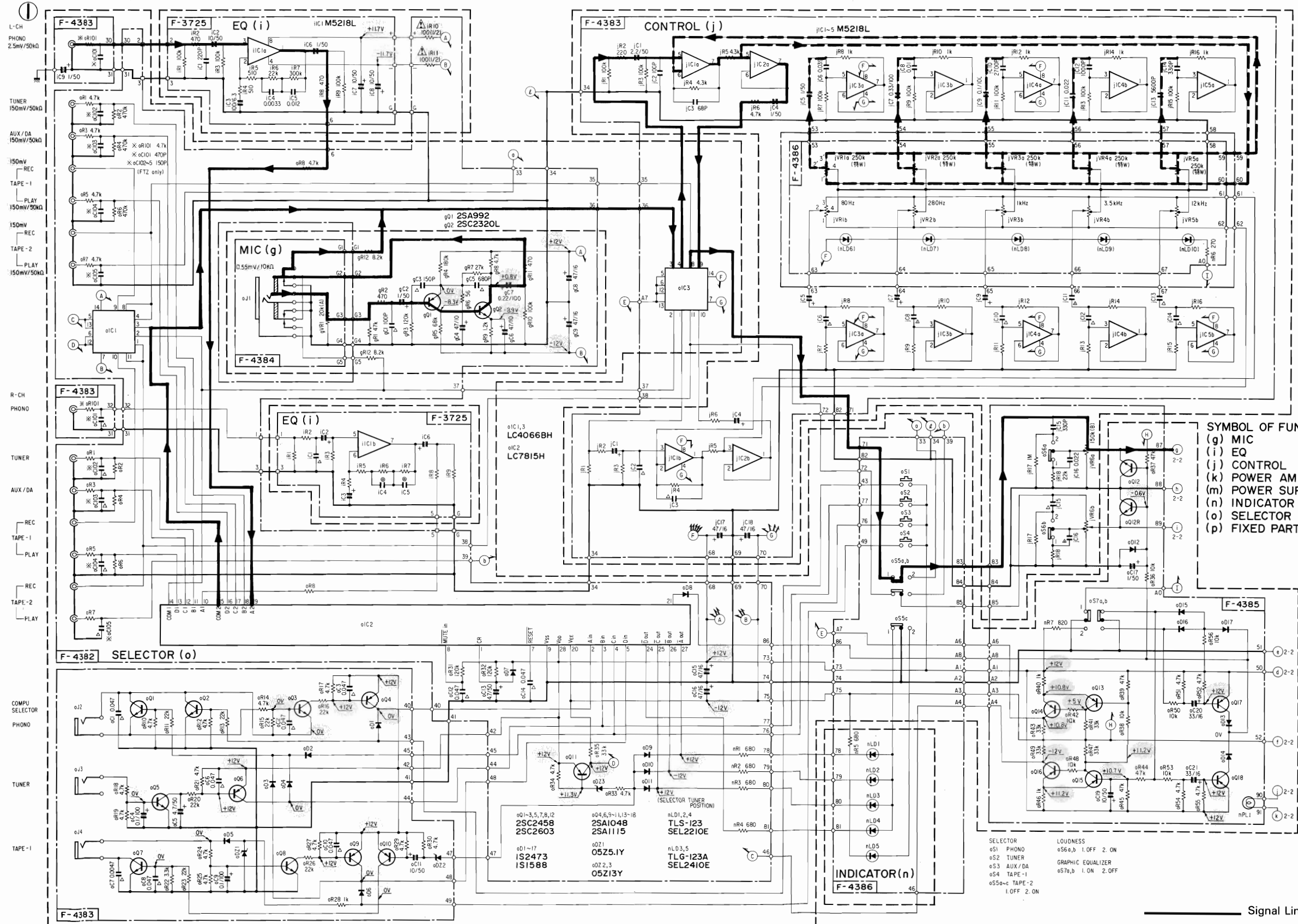

SYMBOL OF FUNCTION
 (g) MIC
 (i) EQ
 (j) CONTROL
 (k) POWER AMP
 (m) POWER SUPPLY
 (n) INDICATOR
 (o) SELECTOR
 (p) FIXED PARTS

- 2SA992
- 2SC1845
- 2SC2320
- 2SA1048
- 2SA1115
- 2SC2458
- 2SC2603
- 2SA1106
- 2SC2581
- 2SB631K
- 2SD600K
- M5218L
- TA7317P
- LC4066BH
- LC7815H
- STK3082-2A
- SEL2210S
- SEL2410E
- TLG123A
- TSL-123
- RD12FB
- 1S1588
- 1S2473T77
- 10E-2
- 30D-2

SELECTOR
 o51 PHONO
 o52 TUNER
 o53 AUX/DA
 o54 TAPE-1
 o55=c TAPE-2
 I OFF 2.0N

LOUDNESS
 o56,b 1. OFF 2. ON
 GRAPHIC EQUALIZER
 o57a,b 1. ON 2. OFF

— Signal Line
 - - - N.F.B. Line

1
 2
 3
 4
 5

4-2. Power Amp. Section

*Design and specifications subject to change without notice for improvement.
 *La présentation et les spécifications sont susceptibles d'être modifiées sans préavis par suites d'améliorations éventuelles.
 *Änderungen, die dem technischen Fortschritt dienen, bleiben vorbehalten.

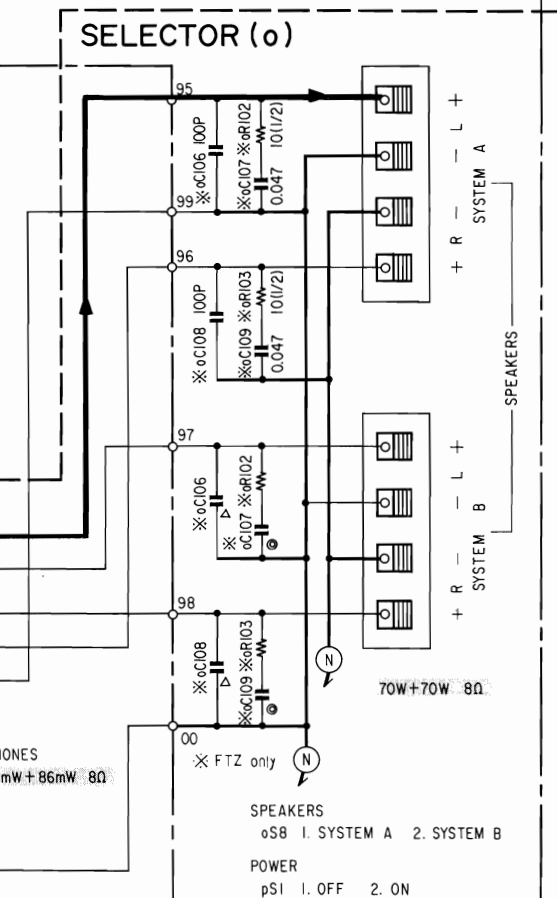
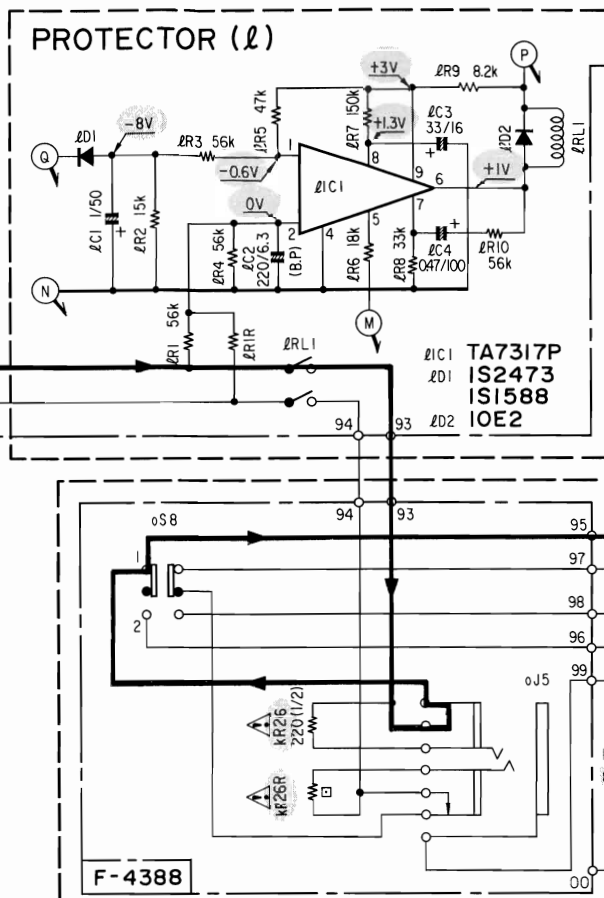
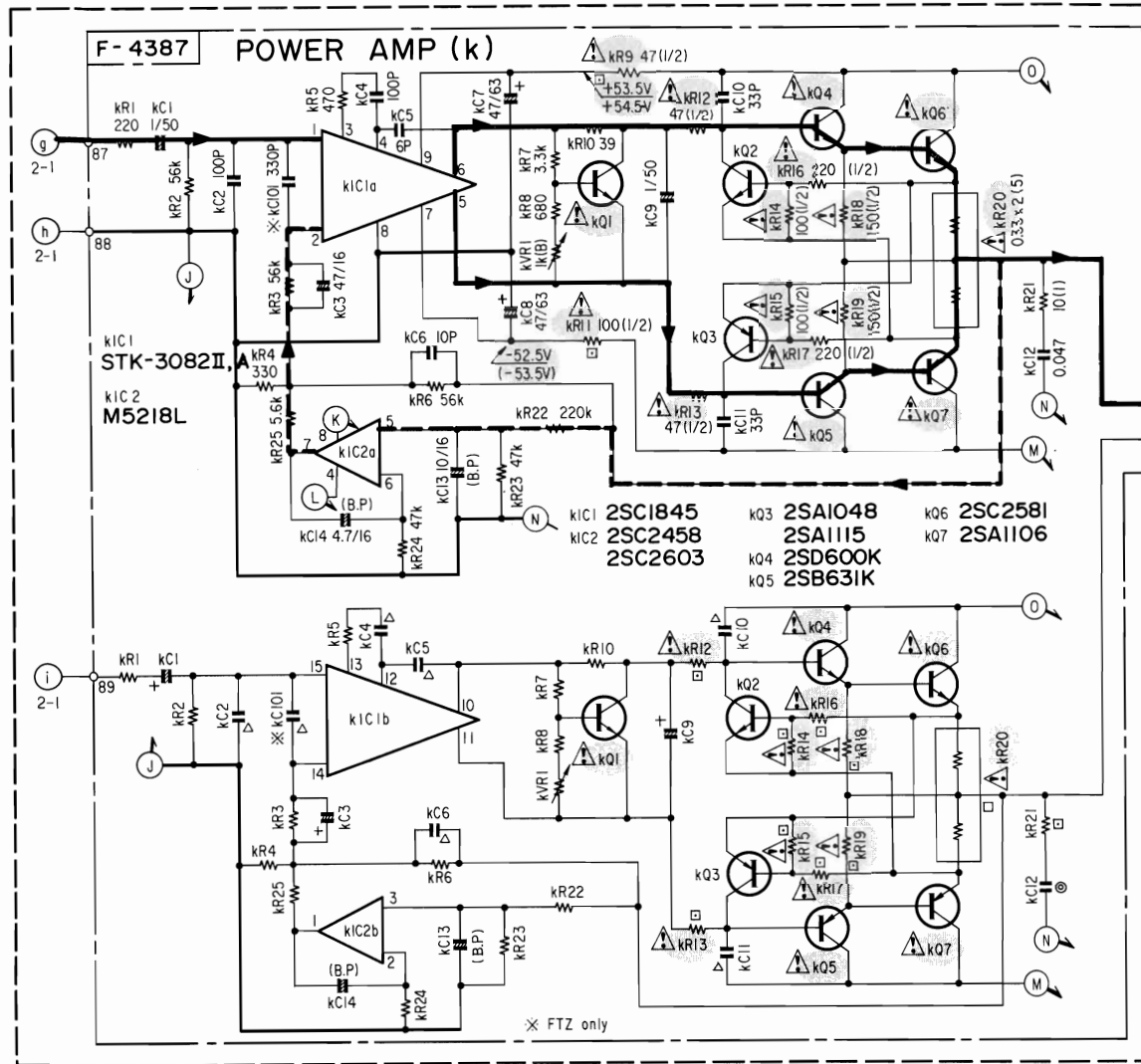

- 2SA992, 2SA1048, 2SC1845, 2SA1115, 2SC2320, 2SC2458, 2SC2603
- 2SA1106, 2SC2581, 2SB631K, 2SD600K
- M5218L
- TA7317P
- LC4066BH
- LC7815H, STK3082-2A
- SEL2210S, 05Z5.1-Y, SEL2410E, 05Z13Y, TLG123A, 05Z24-Y, TSL-123, RD12FB
- 1S1588, 1S2473777, 10E-2, 30D-2

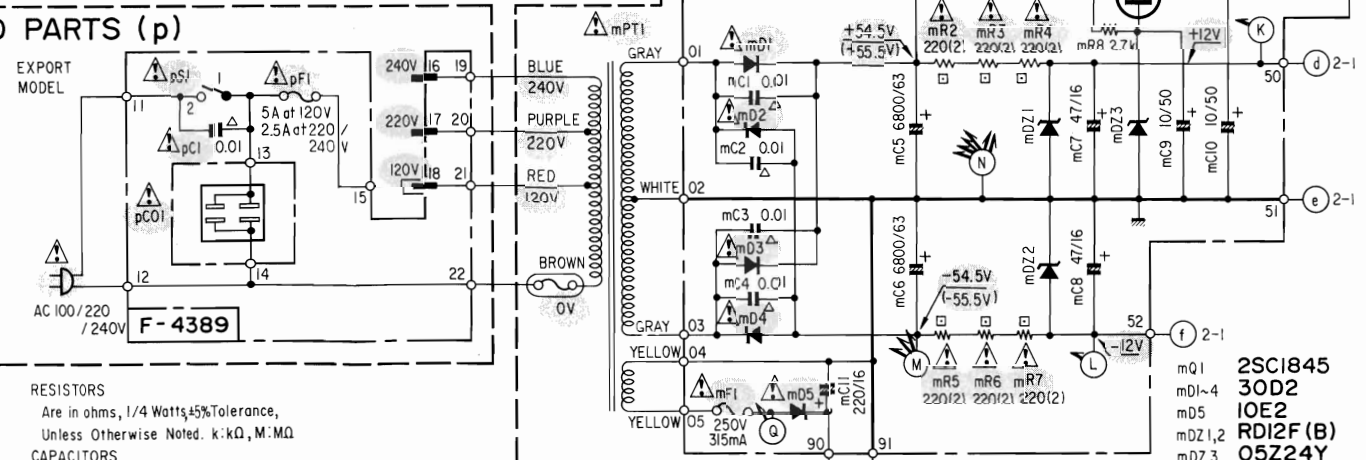
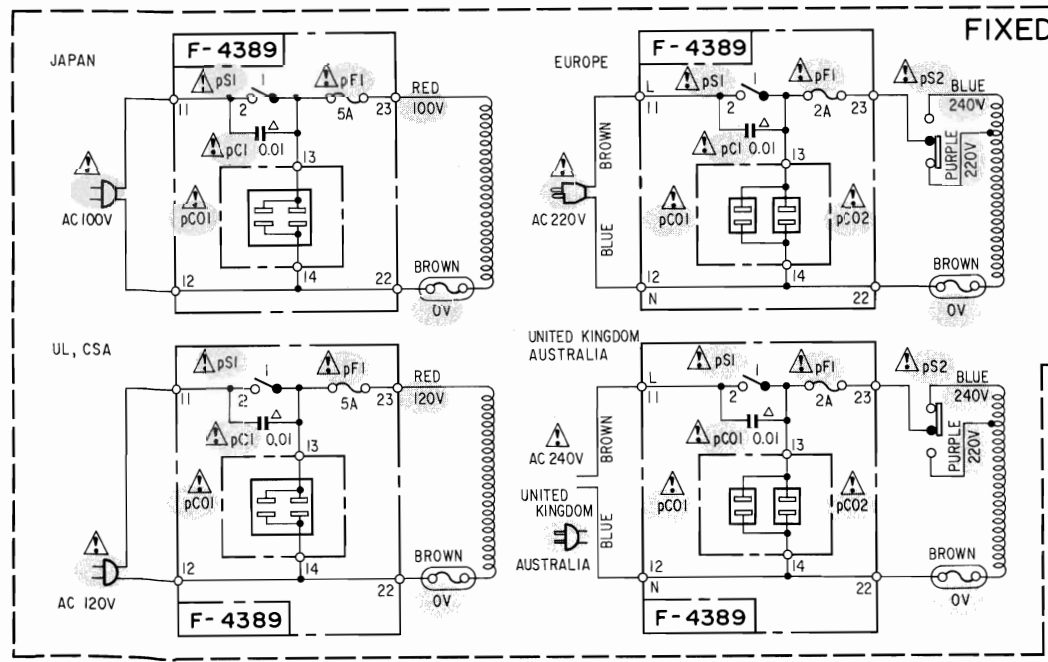

RESISTORS
 Are in ohms, 1/4 Watt±5% Tolerance, Unless Otherwise Noted. k: kΩ, M: MΩ

CAPACITORS
 Are in μF, Unless Otherwise Noted. P: pF
 Electrolytic Capacitor: Capacitance (μF)/Volt (V)

Each D.C. Voltage shows the nominal Value in Volts at no input signal. () JAPAN MODEL only

SYMBOL

- △ Ceramic Capacitor
- ▴ Barrier Layer Capacitor
- Mylar Capacitor
- ⊙ Bipolar Electrolytic Capacitor
- ⊖ Non-Inflammable Resistor
- Cement Resistor

— Signal Line
 - - - N.F.B. Line

5. INTERIOR BLOCK DIAGRAM OF IC

•M5218L (Audio PRE Amp. IC)

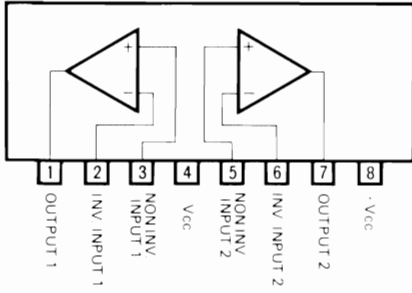

•TA7317P (Protector IC)

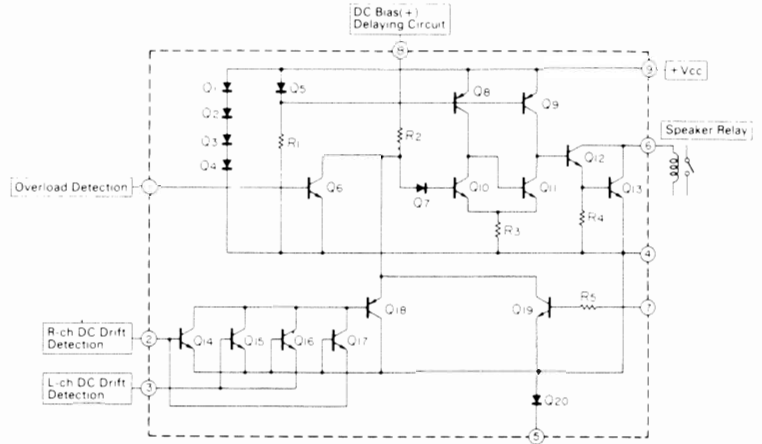

•STK3082-2A (Voltage Amplifier IC)

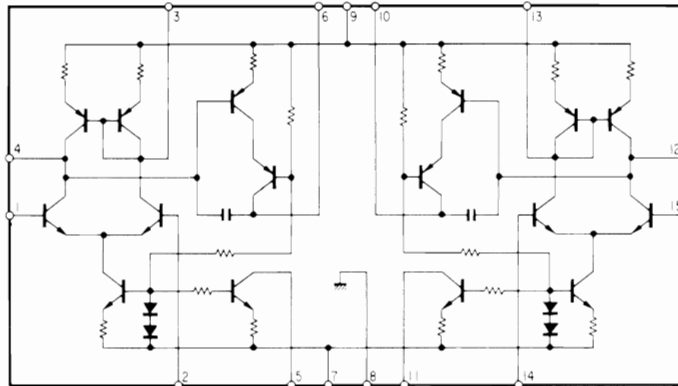

•LC7815H Analog Function Switch IC

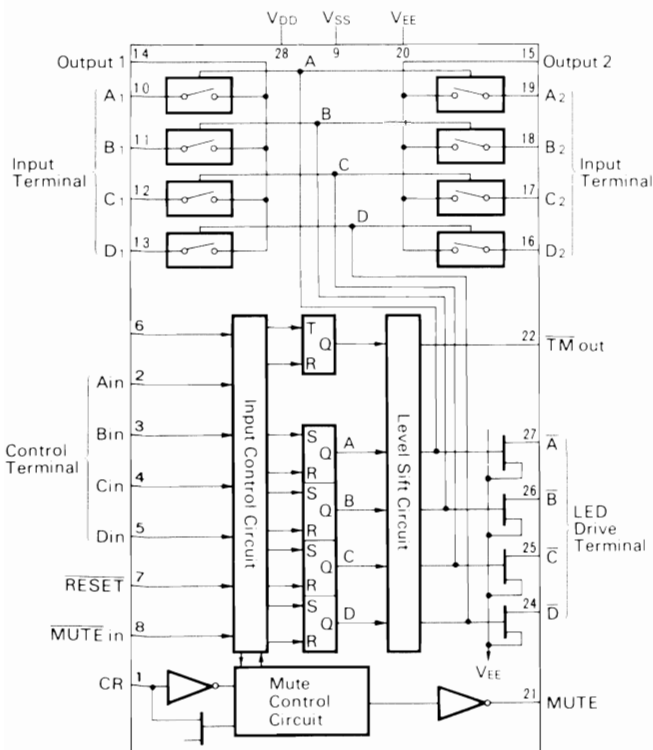

•LC4066BH Quad Bilateral Switch IC

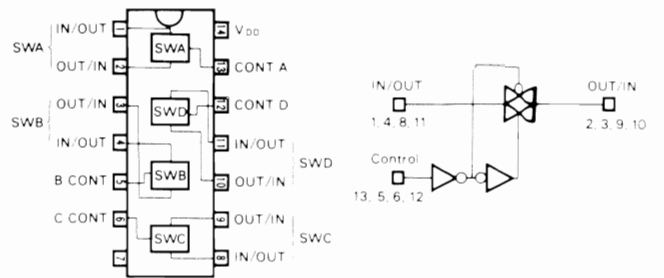

*LC7815H

Condition of control input terminals Port (Pin No.)				Connected input terminal to output 1 and 2 terminals	Connected terminal to LED indicator	
Ain (2)	Bin (3)	Cin (4)	Din (5)	PORT (Pin No.)	PORT (Pin No.)	
H	•	•	•	A1 (10)	A2 (19)	A (27)
L	H	•	•	B1 (11)	B2 (18)	B (28)
L	L	H	•	C1 (12)	C2 (17)	C (25)
L	L	L	H	D1 (13)	D2 (16)	D (24)

H: H level L: L level *: Don't care

6. BIAS CURRENT ADJUSTMENT (See Top View on Page 7)

Note:

1. Room Temperature 18°C ~ 28°C
2. For adjustment, run the unit for more than 3 minutes after the power is switched on.
3. Before turning ON POWER switch, turn kVR1 on F-4387 fully counterclockwise.

STEP	SUBJECT	MEASURE OUTPUT	ADJUST	ADJUST FOR	REMARKS
1.	L-CH	Connect DC volt meter between emitters of kQ6, kQ7 on F-4387	kVR1 (L-CH) F-4387	DC 3.3mV	This bias current adjustment converts current value into voltage by ohms law
2.	R-CH	Same as above	kVR1 (R-CH) F-4387	DC 3.3mV	

7. MAIN PARTS REPLACEMENT

A. Bonnet (See Fig. 7-1)

- 1) Remove two screws SA.
- 2) Push the rear side of the bonnet to remove the hooks and then remove bonnet.

Fig. 7-1

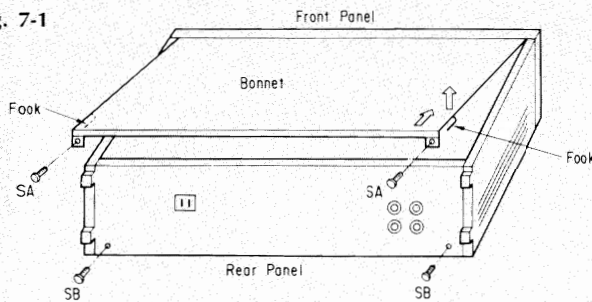

B. Side Panel L(R) (See Fig. 7-1 & 7-2)

- 1) Remove the bonnet and two screws SB.
- 2) Shift the position of the side panel L(R) 1.5 cm in the arrow direction.
- 3) Remove the hooks ② of the side panel from front panel and then pull it to the arrow direction ③ to remove the side panel L(R) (Fig. 7-2).

Fig. 7-2

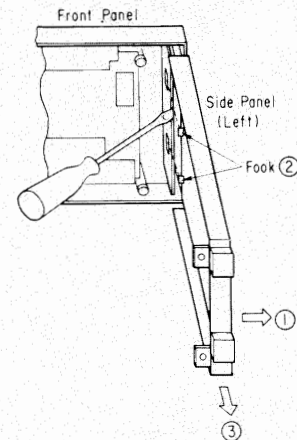

8. PACKING LIST

Parts No.	Stock No.	Description
1	09453300	Vinyl Cover
2	47187620	Styrofoam Packing
3	47355200	Carton Case

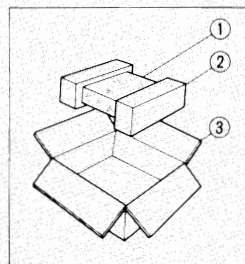

9. ACCESSORY LIST

Parts No.	Stock No.	Description
1	46797700	Operating Instruction



SANSUI ELECTRIC CO., LTD.:
 SANSUI ELECTRONICS CORPORATION:
 SANSUI ELECTRONICS (U.K.) LTD.:
 SANSUI ELECTRONICS G.M.B.H.:

14-1, Izumi 2-chome, Suginami-ku, Tokyo 168 Japan
 PHONE: (03) 324-8891/TELEX: 232-2076 (International Division)
 1250 Valley Brook Ave. Lyndhurst, N.J. 07071 U.S.A.
 17150 South Margay Ave. Carson, California 90746 U.S.A.
 3306 Koapaka 5t. Honolulu, Hawaii 96819 U.S.A.
 Unit 10A, Lyon Industrial Estate, Rockware Avenue, Geenford, Middx UB6, England
 Pau Ehrich Strasse 8, 6074 Rödermark 2, West Germany