

# SERVICE MANUAL

## INTEGRATED STEREO AMPLIFIER

# SANSUI AU-819



### SPECIFICATIONS

- Power output**  
 Min. RMS, both channels driven, from 10 to 20,000 Hz, with no more than 0.008 % total harmonic distortion  
 90 watts per channel into 8 ohms
- Load impedance** . . . . . 8 ohms
- Total harmonic distortion (POWER AMP IN)**  
 . . . . . less than 0.008 % at or below rated min. RMS power output
- Intermodulation distortion (70 Hz : 7 kHz = 4:1 SMPTE method)**  
 . . . . . less than 0.008 % at or below rated min. RMS power output
- Rise time** . . . . . 0.5  $\mu$ sec
- Slew rate** . . . . .  $\pm 200V/\mu$ sec
- Frequency response (at 1 watt) (POWER AMP IN)**  
 . . . . . DC to 500,000 Hz +0 dB -3 dB
- Damping factor (1 kHz, both channels driven)**  
 . . . . . 100 into 8 ohms
- RIAA curve deviation (PHONO, 20 Hz to 20 kHz)**  
 . . . . . +0.2 dB, -0.2 dB
- Input sensitivity and impedance (1 kHz, for rated power output)**  
 PHONO-1 (MC) . . . . . 0.1 mV/10 ohms  
 (Max. input capability; 30 mV at 1 kHz, less than 0.03 % total harmonic distortion)  
 PHONO-1, 2 (MM) . . . . . 2.5 mV/47 kilohms  
 (Max. input capability; 350 mV at 1 kHz, less than 0.01 % total harmonic distortion)
- AUX, TUNER, TAPE PLAY**  
 . . . . . 150 mV/47 kilohms
- POWER AMP IN** . . . . . 1 V/47 kilohms
- Output level and impedance (1,000 Hz)**  
 TAPE REC . . . . . 150 mV into 47 kilohms/600 ohms  
 PREAMP OUT . . . . . 1 V into 47 kilohms/1.5 kilohms
- Channel separation (1 kHz, at rated power output)**  
 PHONO-1 (MC) . . . . . 70 dB  
 PHONO-1, 2 (MM) . . . . . 70 dB  
 AUX, TUNER, TAPE PLAY  
 . . . . . 80 dB
- Hum and noise (short-circuit, A-network)**  
 PHONO-1 (MC) . . . . . 74 dB  
 PHONO-1, 2 (MM) . . . . . 90 dB  
 AUX, TUNER, TAPE PLAY  
 . . . . . 100 dB
- Controls**  
 BASS . . . . .  $\pm 6$  dB (50 Hz)  
 Tone selector . . . . . 150 Hz, 300 Hz  
 TREBLE . . . . .  $\pm 6$  dB (15 kHz)  
 Tone selector . . . . . 3 kHz, 6 kHz  
 SUBSONIC . . . . . -3 dB (16 Hz), 6 dB/oct  
 LOUDNESS (-30 dB)  
 . . . . . 10 dB at 50 Hz  
 . . . . . 4 dB at 10 kHz
- Power requirements**  
 Power voltage . . . . . 100, 120, 220, 240 V (50/60 Hz)  
 Power consumption  
 Rated consumption  
 . . . . . 465 watts
- Dimensions** . . . . . 430 mm (16-15/16") W  
 168 mm (6-5/8") H  
 428 mm (16-7/8") D
- Weight** . . . . . 21.1 kg (46.5 lbs) net  
 22.9 kg (50.5 lbs) packed

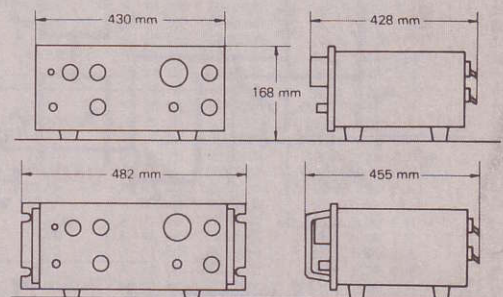

\* Design and specifications subject to changes without notice for improvements.  
 \* In order to simplify the explanation illustrations may sometimes differ from the originals.





◇ MC Head Amp and Equalizer Amp Circuit

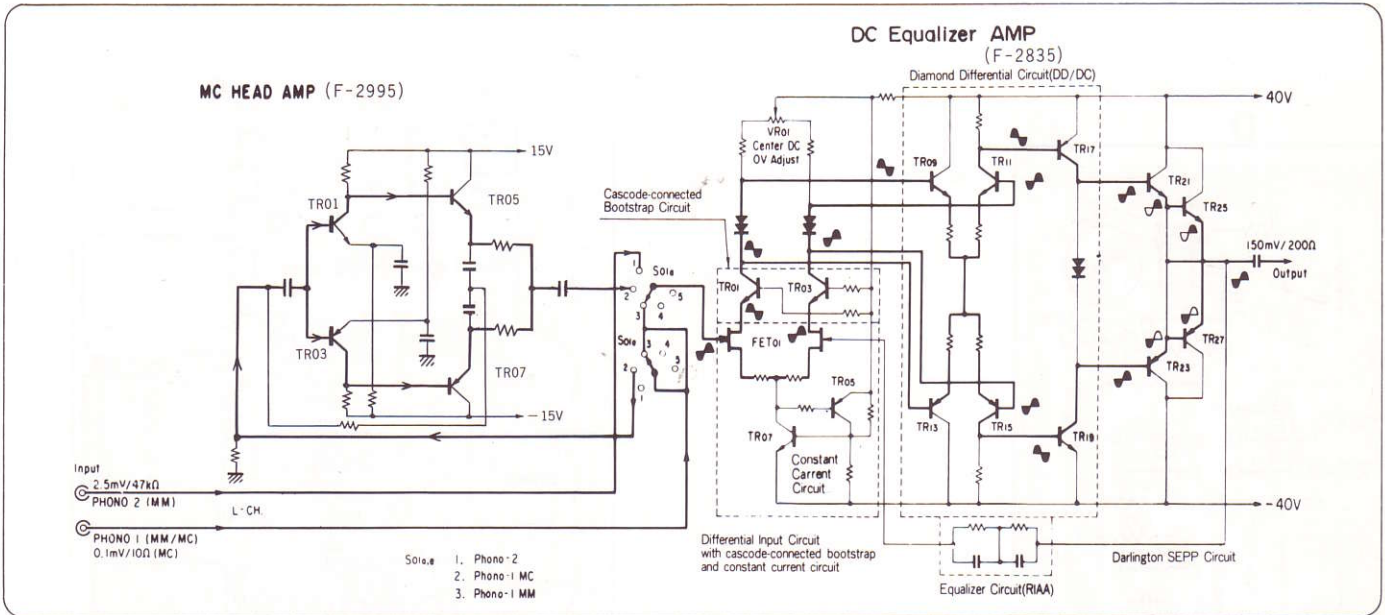

## 2. ADJUSTMENTS

- Notes: 1. Master Volume . . . . . Minimum  
 2. Room Temperature . . . . . 18°C ~ 28°C  
 (65°F ~ 83°F)

3. When replacing some parts or circuit board, refer to description in REMARKS.  
 4. For this adjustment, run the unit for more than 3 minutes after the power is switched ON.

### 2-1. Driver Circuit (F-2839) Adjustment (See Fig. 2-1 & 2-4)

STEP	SUBJECT	MEASURE OUTPUT	ADJUST	ADJUST FOR	REMARKS
1	DC 0V Adj. L-ch	Speaker terminal (L-ch)	VR01 (L-ch) F-2839	DC 0V ± 5 mV	Before turning ON power switch, set VR01 & VR02 to center position.
2	DC 0V Adj. R-ch	Speaker terminal (R-ch)	VR02 (R-ch) F-2839		
3	Bias current Adj. L-ch	Between emitters of power transistors, TR701 & TR703 (between A & B in Fig. 2-1)	VR03 (L-ch) F-2839	DC 20 mV ± 1 mV	• Before turning ON power switch, turn VR03 & VR04 fully counter-clockwise. This bias current adjustment converts current value into voltage by Ohm's law.
4	Bias current Adj. R-ch	Between emitters of power transistors, TR702 & TR704 (between C & D in Fig. 2-1)	VR04 (R-ch) F-2839		

### 2-2. Flat Amp (F-2841) Adjustment (See Fig. 2-2)

STEP	SUBJECT	MEASURE OUTPUT	ADJUST	ADJUST FOR	REMARKS
1	DC 0V Adj. L-ch	Between GND & TEST POINT from emitter of TR13 through R43 (TEST POINT between ⊕ & ⊖ in Fig. 2-2)	VR01 (L-ch) F-2841	DC 0V ± 10 mV	Before turning ON power switch, set VR01 & VR02 to center position.
2	DC 0V Adj. R-ch	Between GND & TEST POINT from emitter of TR14 through R44 (TEST POINT between ⊕ & ⊖ in Fig. 2-2)	VR02 (R-ch) F-2841		

### 2-3. Equalizer (F-2835) Adjustment (See Fig. 2-3)

STEP	SUBJECT	MEASURE OUTPUT	ADJUST	ADJUST FOR	REMARKS
1	DC 0V Adj. L-ch	Between GND & common joint of R67, R69 (between GND and E)	VR01 (L-ch) F-2835	DC 0V ± 50 mV	Before turning ON power switch, set VR01 & VR02 to center position.
2	DC 0V Adj. R-ch	Between GND & common joint of R68, R70 (between GND and F)	VR02 (R-ch) F-2835		

Fig. 2-1

▼Rear Side

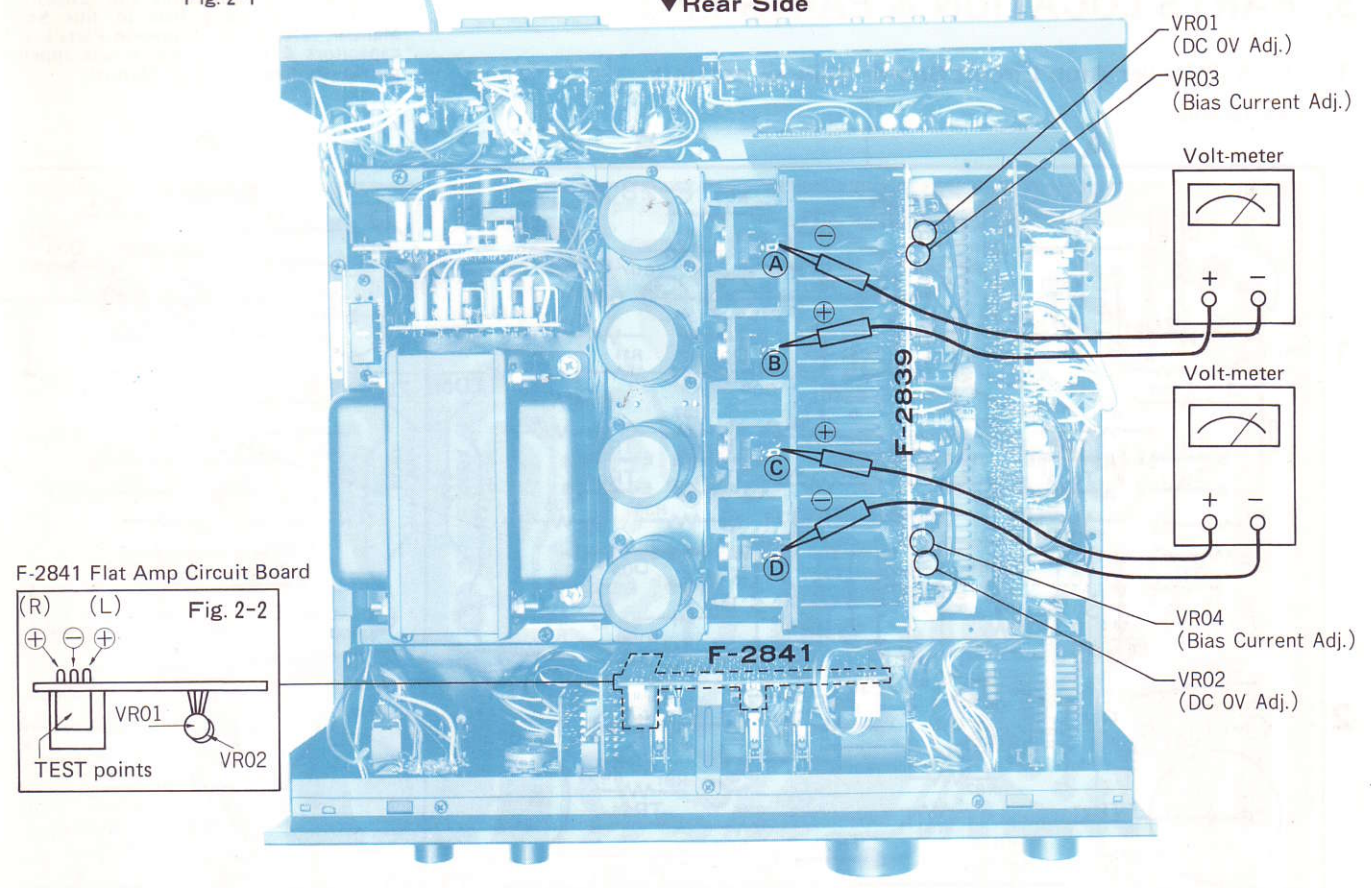

F-2841 Flat Amp Circuit Board

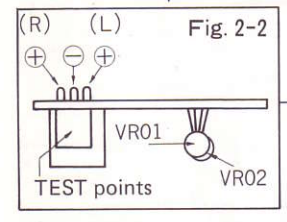

Fig. 2-3 F-2835 Equalizer Amp Circuit Board (Component side)

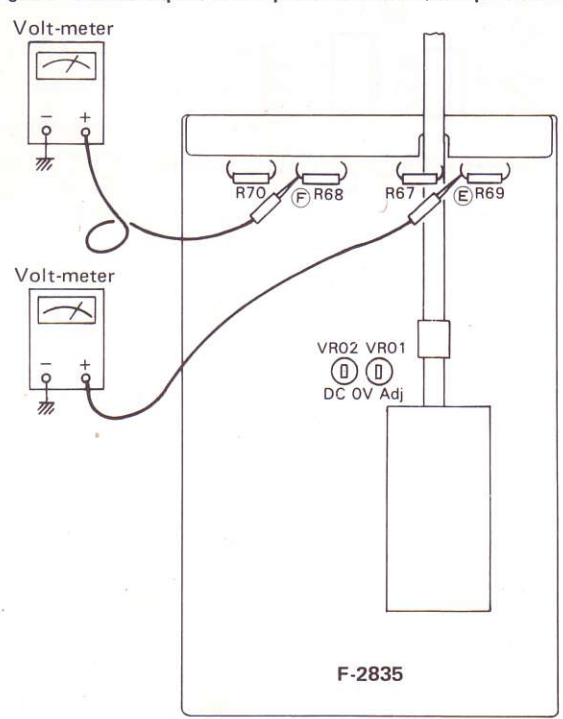
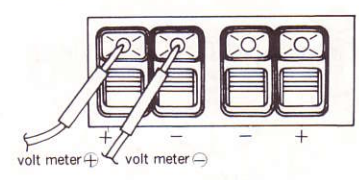

Fig. 2-4 SPEAKER TERMINAL



### 3. PARTS LOCATION & PARTS LIST

#### 3-1. F-2839 Driver Amp Circuit Board (Stock No. 7572161)

Since some of capacitors and resistors are omitted from parts lists in this Service Manual, refer to the Common Parts List for capacitors & resistors which was appended previously to each Sansui Manual.

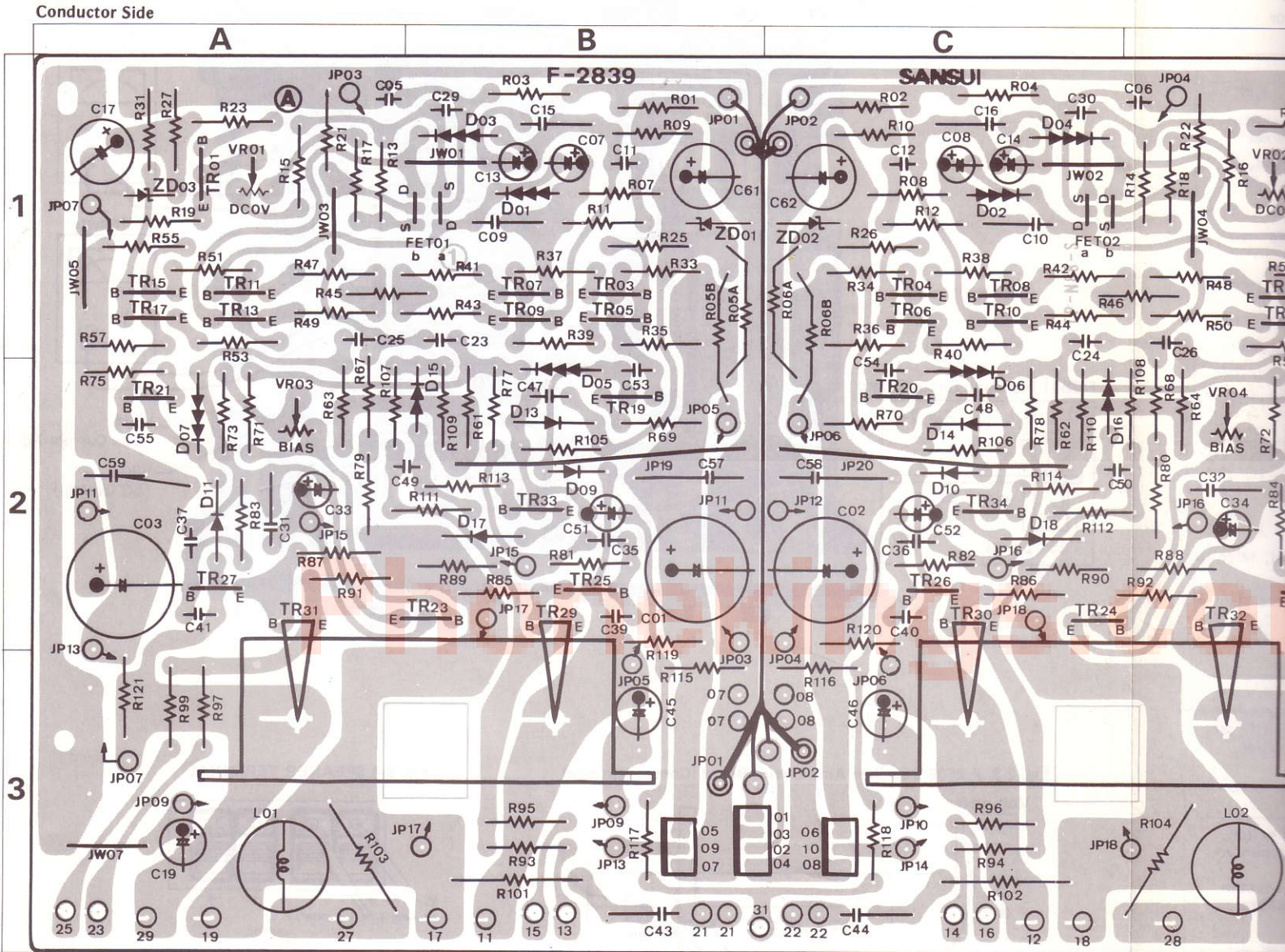

#### Parts List

Parts No.	Stock No.	Description	Position
<b>•Transistors</b>			
TR01, 02	0306680, 1	2SC2071 B, V	1A.1D
TR03, 04	0306740, 1	2SC1845 F, E	1B.1C
TR05, 06	0306740, 1	2SC1845 F, E	1B.1C
TR07, 08	0306740, 1	2SC1845 F, E	1B.1C
TR09, 10	0306740, 1	2SC1845 F, E	1B.1C
TR11, 12	0301090, 1	2SA992 F, E	1A.1D
TR13, 14	0301090, 1	2SA992 F, E	1A.1D
TR15, 16	0301090, 1	2SA992 F, E	1A.1D
TR17, 18	0301090, 1	2SA992 F, E	1A.1D
TR19, 20	0301030, 1	2SA939 B, V	2B.2C
TR21, 22	0306680, 1	2SC2071 B, V	2A.2D
TR23, 24	0306740, 1	2SC1845 F, E	2B.2C
TR25, 26	0306680, 1	2SC2071 B, V	2B.2C
TR27, 28	0301030, 1	2SA939 B, V	2A.2D
TR29, 30	0308441 ~ 3	2SD382 M, L, K	2B.2C
TR31, 32	0303271 ~ 3	2SB537 M, L, K	2A.2D
TR33, 34	0306740, 1	2SC1845 F, E	3B.2C
<b>•FET</b>			
FET01, 02	0370311, 2	2SK129 L, M	1B.1C
<b>•Varistors</b>			
D 01, 02	0340170	MV103	1B.1C
D 03, 04	0340170	MV103	1B.1C
D 15, 16	0340150	MV12	2B.2C
<b>•Diodes</b>			
D 13, 14	0310400	1N34A	2B.2C
D 17, 18	0311160	1S2473D	2B.2C

Parts No.	Stock No.	Description	Position
<b>•Zener Diodes</b>			
ZD01, 02	0317190	RD27F B	1B.1C
ZD03, 04	0316310	RD13E B	1D.1D
C 05, 06	0622121	120pF 125V P.C.	1A.1D
C 09, 10	0680037	0.033μF 100V M.C.	1B.1C
C 11, 12	0622681	680pF 125V P.C.	1B.1C
C 15, 16	0680037	0.033μF 100V M.C.	1B.1C
C 23, 24	0623309	3pF 125V P.C.	1B.1C
C 25, 26	0623309	3pF 125V P.C.	1A.1D
C 29, 30	0623220	22pF 125V P.C.	1B.1C
C 31, 32	0680041	0.047μF 100V M.C.	2A.2D
C 35, 36	0680001	0.001μF 100V M.C.	2B.2C
C 37, 38	0680001	0.001μF 100V M.C.	2A.2D
C 39, 40	0623300	33pF 125V P.C.	2B.2C
C 41, 42	0623300	33pF 125V P.C.	2A.2D
C 43, 44	0681014	0.047μF 400V M.C.	3B.3C
C 47, 48	0680001	0.001μF 100V M.C.	2B.2C
C 49, 50	0680001	0.001μF 100V M.C.	2B.2C
C 53, 54	0623309	3pF 125V P.C.	2B.2C
C 55, 56	0623309	3pF 125V P.C.	2A.2D
R 01, 02	0280563	56kΩ 1/3W C.R.	1B.1C
R 03, 04	0280391	390Ω 1/3W C.R.	1B.1C
R 05, 06	0212152	1.5kΩ 2W N.I.R.	1B.1C
R 07, 08	0280392	3.9kΩ 1/3W C.R.	1B.1C
R 09, 10	0280392	3.9kΩ 1/3W C.R.	1B.1C
R 11, 12	0280471	470Ω 1/3W C.R.	1B.1C
R 13, 14	0280121	120Ω 1/3W C.R.	1A.1D
R 15, 16	0280560	56Ω 1/3W C.R.	1A.1D

Parts No.	Stock No.	Description	Position
R 17, 18	0280560	56Ω 1/3W C.R.	1A.1D
R 19, 20	0210152	1.5kΩ 1/2W N.I.R.	1A.1D
R 21, 22	0280391	390Ω 1/3W C.R.	1A.1D
R 23, 24	0280392	3.9kΩ 1/3W C.R.	1A.1D
R 25, 26	0280101	100Ω 1/3W C.R.	1B.1C
R 27, 28	0280103	10kΩ 1/3W C.R.	1A.1D
R 31, 32	0280101	100Ω 1/3W C.R.	1A.1D
R 33, 34	0280821	820Ω 1/3W C.R.	1B.1C
R 35, 36	0280101	100Ω 1/3W C.R.	1B.1C
R 37, 38	0280101	100Ω 1/3W C.R.	1B.1C
R 39, 40	0280101	100Ω 1/3W C.R.	1B.1C
R 41, 42	0280151	150Ω 1/3W C.R.	1B.1C
R 43, 44	0280151	150Ω 1/3W C.R.	1B.1C
R 45, 46	0280100	10Ω 1/3W C.R.	1A.1D
R 47, 48	0280151	150Ω 1/3W C.R.	1A.1D
R 49, 50	0280151	150Ω 1/3W C.R.	1A.1D
R 51, 52	0280101	100Ω 1/3W C.R.	1A.1D
R 53, 54	0280101	100Ω 1/3W C.R.	1A.1D
R 55, 56	0280821	820Ω 1/3W C.R.	1A.1D
R 57, 58	0280821	820Ω 1/3W C.R.	1A.1D
R 61, 62	0280393	39kΩ 1/3W C.R.	2B.2C
R 63, 64	0280393	39kΩ 1/3W C.R.	2A.2D
R 67, 68	0280103	10kΩ 1/3W C.R.	2A.2D
R 69, 70	0280121	120Ω 1/3W C.R.	2B.2C
R 71, 72	0280562	5.6kΩ 1/3W C.R.	2A.2D
R 73, 74	0280821	820Ω 1/3W C.R.	2A.2D
R 75, 76	0280121	120Ω 1/3W C.R.	2A.2D
R 77, 78	0280560	56Ω 1/3W C.R.	2B.2C
R 79, 80	0280820	82Ω 1/3W C.R.	2A.2D
R 81, 82	0280391	390Ω 1/3W C.R.	2B.2C

Parts No.	Stock No.	Description	Position
R 83, 84	0280101	100Ω 1/3W C.R.	02B
R 85, 86	0280101	100Ω 1/3W C.R.	02B
R 87, 88	0280101	100Ω 1/3W C.R.	02B
R 89, 90	0280101	100Ω 1/3W C.R.	02B
R 91, 92	0280101	100Ω 1/3W C.R.	02B
R 93, 94	0280101	100Ω 1/3W C.R.	02B
R 97, 98	0280101	100Ω 1/3W C.R.	02B
R 101, 102	0280101	100Ω 1/3W C.R.	02B
R 103, 104	0280101	100Ω 1/3W C.R.	02B
R 105, 106	0280101	100Ω 1/3W C.R.	02B
R 107, 108	0280101	100Ω 1/3W C.R.	02B
R 109, 110	0280101	100Ω 1/3W C.R.	02B
R 111, 112	0280101	100Ω 1/3W C.R.	02B
R 113, 114	0280101	100Ω 1/3W C.R.	02B
R 115, 116	0280101	100Ω 1/3W C.R.	02B
R 117, 118	0280101	100Ω 1/3W C.R.	02B
R 119, 120	0280101	100Ω 1/3W C.R.	02B
R 121, 122	0280101	100Ω 1/3W C.R.	02B
L 01, 02	4290		
VR01, 02	103		
VR03, 04	103		



3-3. F-2835 Equalizer Amp Circuit Board (Stock No. 7551391)

Conductor Side

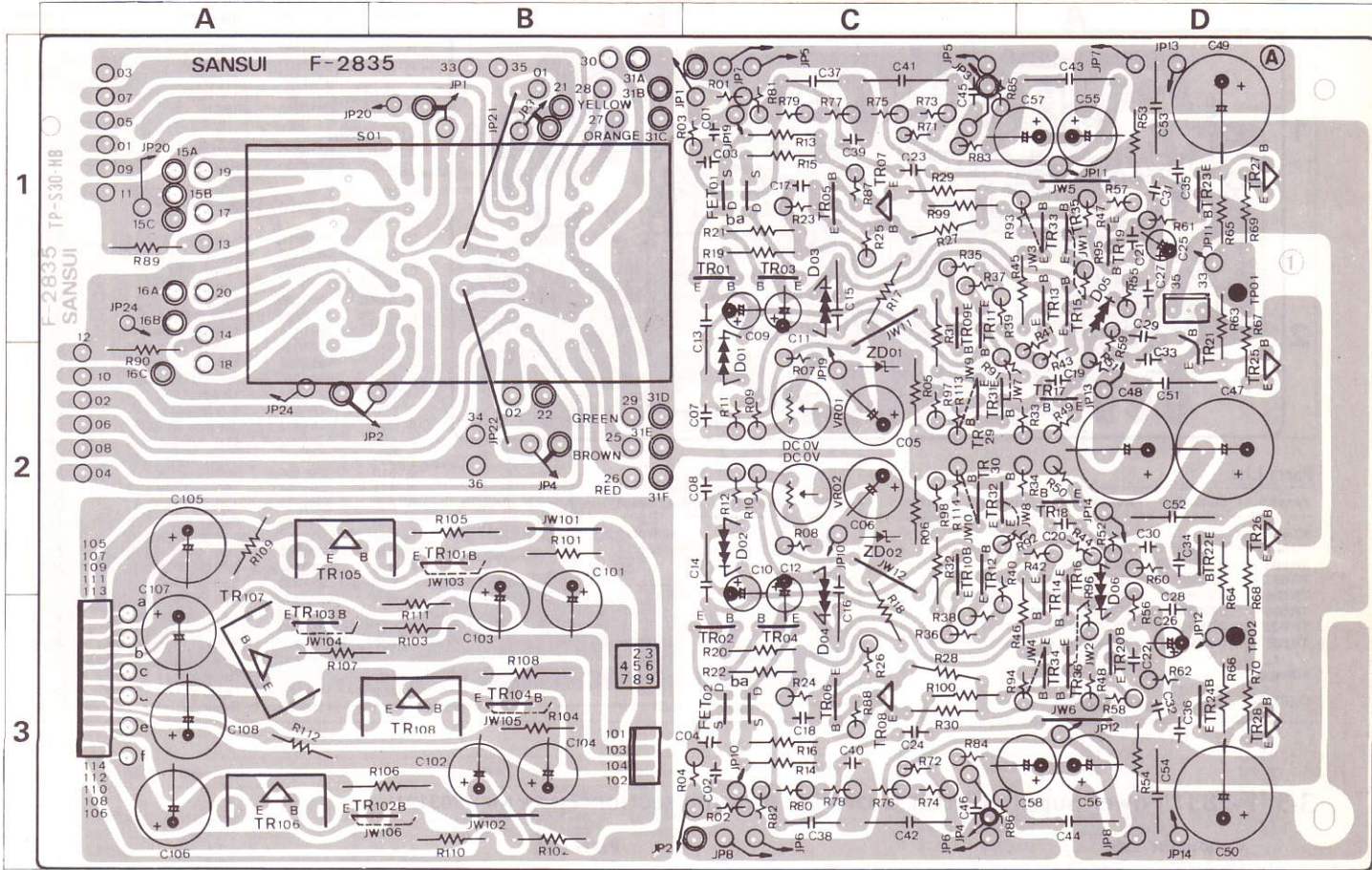

Parts List

Parts No.	Stock No.	Description	Position	Parts No.	Stock No.	Description	Position	Parts No.	Stock No.	Description	Position
<b>•Transistors</b>											
TR01,02	0306740,1	2SC1845 F,E	1C.3C	C 19,20	0623609	6pF 125V P.C.	2D	R 39,40	0281680	68Ω 1/3W C.R.	1C.3C
TR03,04	0306740,1	2SC1845 F,E	1C.3C	C 21,22	0623609	6pF 125V P.C.	1D.3D	R 41,42	0281181	180Ω 1/3W C.R.	2D
TR05,06	0301090,1	2SA992 F,E	1C.3C	C 23,24	0623909	9pF 125V P.C.	1C.3C	R 43,44	0281181	180Ω 1/3W C.R.	2D
TR07,08	0306680,1	2SC2071 B,V	1C.3C	C 27,28	0680041	0.047μF 100V M.C.	1D.3D	R 45,46	0280821	820Ω 1/3W C.R.	1D.3D
TR09,10	0306740,1	2SC1845 F,E	1C.2C	C 29,30	0680001	0.001μF 100V M.C.	1D.2D	R 47,48	0281821	820Ω 1/3W C.R.	1D.3D
TR11,12	0306740,1	2SC1845 F,E	1C.2C	C 31,32	0680001	0.001μF 100V M.C.	1D.3D	R 49,50	0281121	120Ω 1/3W C.R.	2D
TR13,14	0301090,1	2SA992 F,E	1D.2D,3D	C 33,34	0623220	22pF 125V P.C.	2D	R 51,52	0281393	39kΩ 1/3W C.R.	2D
TR15,16	0301090,1	2SA992 F,E	1D.2D	C 35,36	0623220	22pF 125V P.C.	1D.3D	R 53,54	0280393	39kΩ 1/3W C.R.	1D.3D
TR17,18	0301090,1	2SA992 F,E	2D	C 37,38	0682023	0.033μF 100V M.C.	1C.3C	R 55,56	0281331	330Ω 1/3W C.R.	1D.2D
TR19,20	0306740,1	2SC1845 F,E	1D.2D	C 39,40	0622202	2000pF 125V P.C.	1C.3C	R 57,58	0281121	120Ω 1/3W C.R.	1D.3D
TR21,22	0306740,1	2SC1845 F,E	1D.2D,3D	C 41,42	0682037	0.12μF 100V M.C.	1C.3C	R 59,60	0281391	390Ω 1/3W C.R.	1D.2D
TR23,24	0301090,1	2SA992 F,E	1D.2D	C 43,44	0680065	0.47μF 100V M.C.	1D.3D	R 61,62	0281391	390Ω 1/3W C.R.	1D.3D
TR25,26	0306680,1	2SC2071 B,V	2D,3D	C 45,46	0680013	0.0033μF 100V M.C.	1C.3C	R 63,64	0210331	330Ω 1/2W N.I.R.	1D.2D
TR27,28	0301030,1	2SA939 B,V	1D.3D	C 51,52	0680057	0.22μF 100V M.C.	2D	R 65,66	0210331	330Ω 1/2W N.I.R.	1D.3D
TR101,102	0306740,1	2SC1845 F,E	2B.3B	C 53,54	0680057	0.22μF 100V M.C.	1D.3D	R 67,68	0210330	33Ω 1/2W N.I.R.	1D.2D
TR103,104	0301090,1	2SA992 F,E	3A,3B	R 01,02	0281104	100kΩ 1/3W C.R.	1C.3C	R 69,70	0210330	33Ω 1/2W N.I.R.	1D.3D
<b>•FET</b>											
FET01,02	0370350	2SK146	1C.3C	R 03,04	0281470	47Ω 1/3W C.R.	1C.3C	R 71,72	0281470	47Ω 1/3W C.R.	1C.3C
<b>•Varistors</b>											
D 01,02	0340170	MV103	2C	R 05,06	0210102	1kΩ 1/2W N.I.R.	2C	R 73,74	0231203	20kΩ 1/2W M.R.	1C.3C
D 03,04	0340170	MV103	1C.2C,3C	R 07,08	0281182	1.8kΩ 1/3W C.R.	2C	R 75,76	0231682	6.8kΩ 1/2W M.R.	1C.3C
D 05,06	0340170	MV103	1D.2D	R 09,10	0281182	1.8kΩ 1/3W C.R.	2C	R 77,78	0231182	1.8kΩ 1/2W M.R.	1C.3C
<b>•Zener Diodes</b>											
ZD01,02	0316530	RD27E B		R 11,12	0281470	47Ω 1/3W C.R.	2C	R 79,80	0231391	390Ω 1/2W M.R.	1C.3C
C 01,02	0622151	150pF 125V P.C.	1C.3C	R 13,14	0280229	2.2Ω 1/3W C.R.	1C.3C	R 81,82	0231470	47Ω 1/2W M.R.	1C.3C
C 03,04	0623220	22pF 125V P.C.	1C.3C	R 15,16	0280229	2.2Ω 1/3W C.R.	1C.3C	R 83,84	0281561	560Ω 1/3W C.R.	1C.3C
C 07,08	0680014	0.0036μF 100V M.C.	2C	R 17,18	0280393	39kΩ 1/3W C.R.	1C.3C	R 85,86	0281104	100kΩ 1/3W C.R.	1C.3C
C 13,14	0680037	0.033μF 100V M.C.	1C.2C	R 19,20	0280101	100Ω 1/3W C.R.	1C.3C	R 87,88	0281331	330Ω 1/3W C.R.	1C.3C
C 15,16	0680037	0.033μF 100V M.C.	1C.2C	R 21,22	0280101	100Ω 1/3W C.R.	1C.3C	R 89,90	0280104	100kΩ 1/3W C.R.	1A.2A
C 17,18	0680001	0.001μF 100V M.C.	1C.3C	R 23,24	0280101	100Ω 1/3W C.R.	1C.3C	R 101,102	0280822	8.2kΩ 1/3W C.R.	2B.3B
				R 25,26	0281103	10kΩ 1/3W C.R.	1C.3C	R 103,104	0280822	8.2kΩ 1/3W C.R.	3B
				R 27,28	0280333	33kΩ 1/3W C.R.	1C.3C	R105 ~ 108	0210471	470Ω 1/2W N.I.R.	2B,3A,B
				R 29,30	0210222	2.2kΩ 1/2W N.I.R.	1C.3C	R109 ~ 112	0280512	5.1kΩ 1/3W C.R.	2A,3A,B
				R 31,32	0280821	820Ω 1/3W C.R.	1C.2C				
				R 33,34	0281821	820Ω 1/3W C.R.	2D				
				R 35,36	0281181	180Ω 1/3W C.R.	1C.3C				
				R 37,38	0281181	180Ω 1/3W C.R.	1C.3C				
								VR01,02	1034170,1	220Ω (B) VR, DC 0V	2C
								S 01	1104380	Rotary Switch, input selector	1B

3-4. F-2840 Protector Circuit Board (Stock No. 7597061)

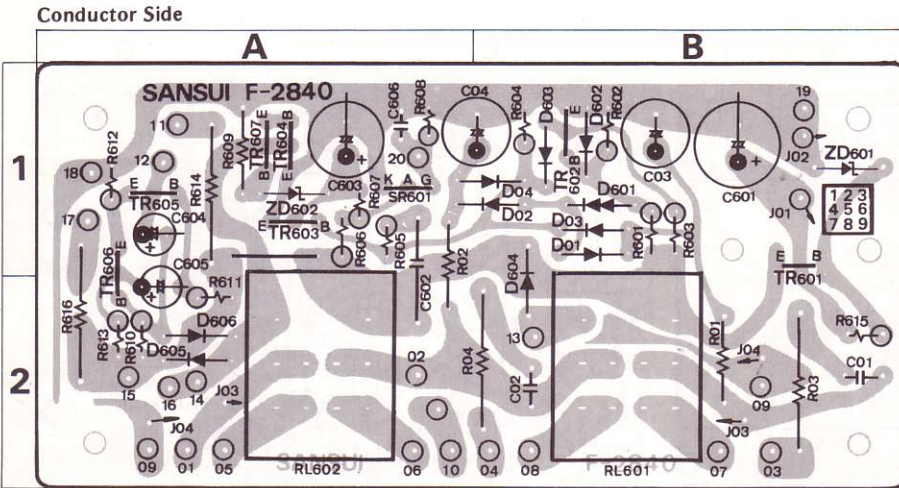

Parts No.	Stock No.	Description	Position
D 605	0310340	10D1	2A
D 606	0311160	1S2473D	2A
	0311180	1S1588	
D 607	0311160	1S2473D	
D 608	0310340	10D1	
●Zener Diodes			
ZD601	0316510	RD24E B	1B
ZD602	0316390	RD6.2E B	1A
●SCR			
SCR601	0350020	2SF656	1A
C			
C 01, 02	0681014	0.047μF 400V M.C.	2B
C 602	0602338	0.33μF 100V M.C.	1, 2A
C 603	0583331	330μF 25V E.C.	
R			
R 01, 02	0280223	22kΩ 1/3W C.R.	2B, 1, 2A
R 03, 04	0212100	10Ω 2W N.I.R.	2B
R 601	0281474	470kΩ 1/3W C.R.	1B
R 602	0281334	330kΩ 1/3W C.R.	1B
R 603	0281104	100kΩ 1/3W C.R.	1B
R 604	0281393	39kΩ 1/3W C.R.	1B
R 605	0281104	100kΩ 1/3W C.R.	1A
R 606	0281472	4.7kΩ 1/3W C.R.	1A
R 607	0281333	33kΩ 1/3W C.R.	1A
R 608	0281102	1kΩ 1/3W C.R.	1A
R 609	0280333	33kΩ 1/3W C.R.	1A
R 610	0281104	100kΩ 1/3W C.R.	2A
R 611	0281104	100kΩ 1/3W C.R.	2A
R 612	0281121	120Ω 1/3W C.R.	1A
R 613	0281682	6.8kΩ 1/3W C.R.	2A
R 614	0212152	1.5kΩ 2W N.I.R.	1A
R 615	0200102	1kΩ 1/2W N.I.R.	2B
R 616	0212152	1.5kΩ 2W N.I.R.	2A
R 617	0281330	33Ω 1/3W C.R.	
R 619	0281330	33Ω 1/3W C.R.	
RL601			
	1150400	Relay	2B
	1150480	Relay	
	1150490	Relay	
RL602			
	1150400	Relay	2A
	1150480	Relay	
	1150490	Relay	

Parts List

Parts No.	Stock No.	Description	Position	Parts No.	Stock No.	Description	Position
●Transistors							
TR 601	0308611, 2	2SD357 D, E	1B	D 03, 04	0311160	1S2473D	1B
TR 602	0305951, 2	2SC945 Q, P	1B		0311180	1S1588	
TR 603	0305951, 2	2SC945 Q, P	1A	●Varistors			
TR 604	0308521, 2	2SD438 E, F	1A	D 601	0340150	MV12	1B
TR 605	9395951, 2	2SC945 Q, P	1A	●Diodes			
TR 606	0305951, 2	2SC945 Q, P	1, 2A	D 602	0311160	1S2473D	1B
TR 607	0305951, 2	2SC945 Q, P	1A	D 603	0311160	1S2473D	1B
				D 604	0310340	10D1	2B
●Diodes							
D 01, 02	0311160	1S2473D	1B				
	0311180	1S1588					

3-5. F-2831 Power Supply Circuit Board for pre-amp section (Stock No. 7503191)

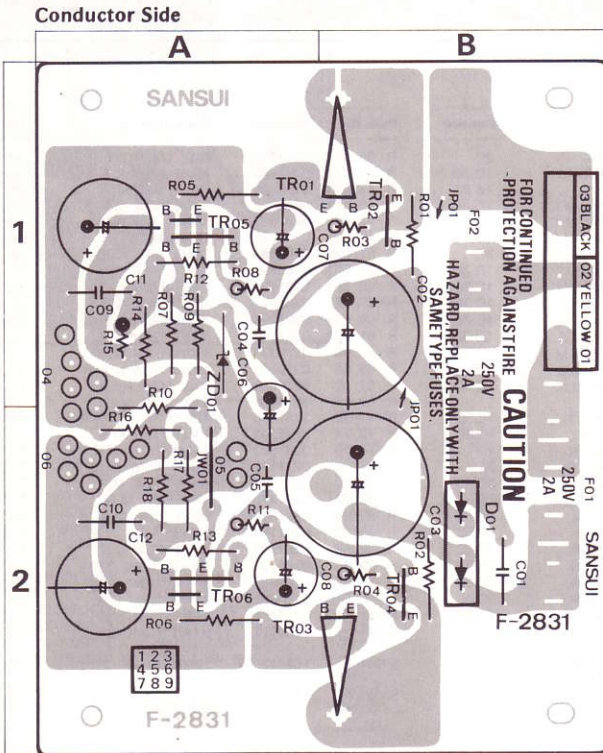

Parts List

Parts No.	Stock No.	Description	Position
●Transistors			
TR 01	0308501, 2	2SD357 D, E	1A
TR 02	0306071, 2	2SC1313 G, H	1B
TR 03	0303331, 2	2SB527 D, E	2A
TR 04	0300470, 1	2SA726 F, G	2B
TR 05	0306730, 1	2SC2259 F, G	1A
TR 06	0301080, 1	2SA979 F, G	2A
●Diode			
D 01	0311700	RB152	2B
●Zener Diode			
ZD01	0316510	RD24E B	1A
C			
C 01	0606108	0.1μF 250V M.C.	2B
C 02	0549207	1000μF 63V E.C.	1B
C 03	0549207	1000μF 63V E.C.	2B
C 09	0602228	0.22μF 100V M.C.	1A
C 10	0602228	0.22μF 100V M.C.	2A
R			
R 01	0210399	3.9Ω 1/2W N.I.R.	1B
R 02	0210399	3.9Ω 1/2W N.I.R.	2B
R 03	0281472	4.7kΩ 1/3W C.R.	1B
R 04	0281472	4.7kΩ 1/3W C.R.	2B
R 05	0210229	2.2Ω 1/2W N.I.R.	1A
R 06	0210229	2.2Ω 1/2W N.I.R.	2A
R 07	0280222	2.2kΩ 1/3W C.R.	1A
R 08	0281103	10kΩ 1/3W C.R.	1A
R 09	0280333	33kΩ 1/3W C.R.	1A
R 10	0280203	20kΩ 1/3W C.R.	2A
R 11	0281103	10kΩ 1/3W C.R.	2A
R 12	0280472	4.7kΩ 1/3W C.R.	1A
R 13	0280472	4.7kΩ 1/3W C.R.	2A
R 14	0280163	16kΩ 1/3W C.R.	1A
R 15	0281243	24kΩ 1/3W C.R.	1A
R 16	0280273	27kΩ 1/3W C.R.	2A
R 17	0280123	12kΩ 1/3W C.R.	2A
R 18	0280393	39kΩ 1/3W C.R.	2A
F			
F 01	0431240	2A 250V AC Fuse	2B
F 02	0431240	2A 250V AC Fuse	1B



3-6. F-2841 Flat Amp Circuit Board (Stock No. 7597071)

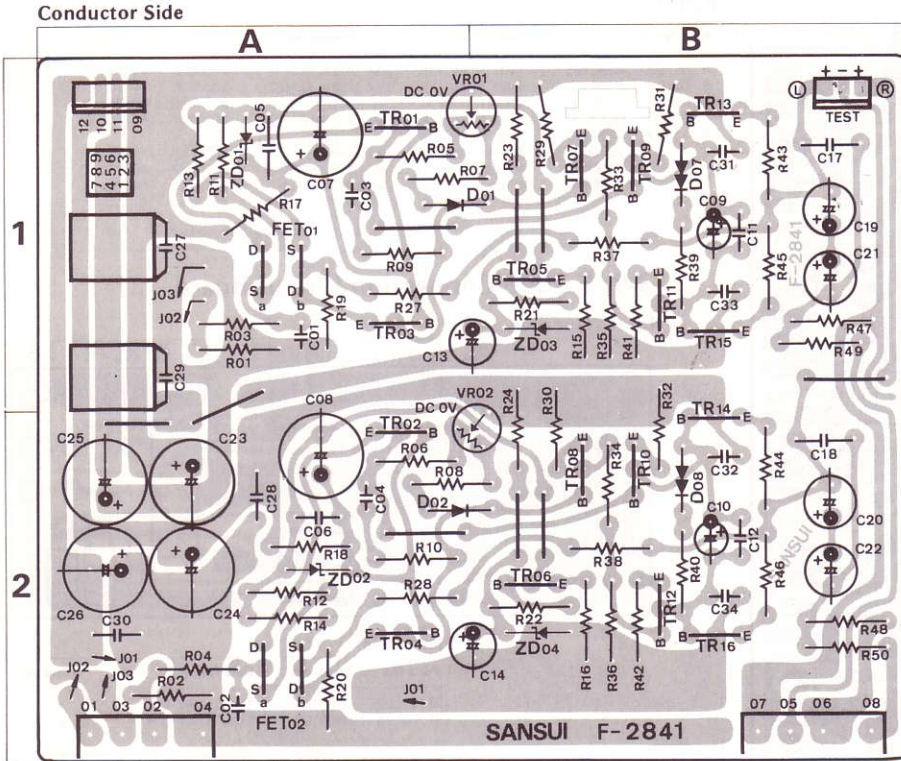

Parts No.	Stock No.	Description	Position
<b>Diodes</b>			
D 01, 02	0311160	1S2473D	1A, B, 2A, B
	0311180	1S1588	
<b>Varistors</b>			
D 07, 08	0340150	MV12	1B, 2B
<b>Zener Diodes</b>			
ZD01, 02	0316240	RD9.1 E C	1A, 2A
ZD03, 04	0316390	RD6.2E B	1B, 2B
C 01, 02	0623330	33pF 125V P.C.	1A, 2A
C 03, 04	0622391	390pF 125V P.C.	1A, 2A
C 05, 06	0680049	0.1μF 100V M.C.	1A, 2A
C 11, 12	0680041	0.047μF 100V M.C.	1B, 2B
C 15, 16	0623509	5pF 125V P.C.	1B, 2B
C 17, 18	0680061	0.33μF 100V M.C.	1B, 2B
C 27, 28	0680057	0.22μF 100V M.C.	1A, 2A
C 29, 30	0680057	0.22μF 100V M.C.	1A, 2A
C 35, 36	0623309	3pF 125V P.C.	1A, 2A
C 37, 38	0623309	3pF 125V P.C.	1A, 2A
R 01, 02	0280304	300kΩ 1/3W C.R.	1A, 2A
R 03, 04	0280101	100Ω 1/3W C.R.	1A, 2A
R 05, 06	0280272	2.7kΩ 1/3W C.R.	1A, 2A
R 07, 08	0280272	2.7kΩ 1/3W C.R.	1A, 2A
R 09, 10	0280152	1.5kΩ 1/3W C.R.	1A, 2A
R 11, 12	0280220	22Ω 1/3W C.R.	1A, 2A
R 13, 14	0280220	22Ω 1/3W C.R.	1A, 2A
R 17, 18	0280333	33kΩ 1/3W C.R.	1A, 2A
R 19, 20	0280122	1.2kΩ 1/3W C.R.	1A, 2A
R 21, 22	0280102	1kΩ 1/3W C.R.	1B, 2A
R 23, 24	0280223	22kΩ 1/3W C.R.	1B, 2B
R 27, 28	0280222	2.2kΩ 1/3W C.R.	1A, 2A
R 29, 30	0280272	2.7kΩ 1/3W C.R.	1B, 2B
R 31, 32	0280102	1kΩ 1/3W C.R.	1B, 2B
R 33, 34	0280101	100Ω 1/3W C.R.	1B, 2B
R 35, 36	0280272	2.7kΩ 1/3W C.R.	1B, 2B
R 37, 38	0280273	27kΩ 1/3W C.R.	1B, 2B
R 39, 40	0280820	82Ω 1/3W C.R.	1B, 2B
R 41, 42	0280102	1kΩ 1/3W C.R.	1B, 2B
R 43, 44	0210470	47Ω 1/2W N.I.R.	1B, 2B
R 45, 46	0210470	47Ω 1/2W N.I.R.	1B, 2B
R 47, 48	0280223	22kΩ 1/3W C.R.	1B, 2B
R 49, 50	0280101	100Ω 1/3W C.R.	1B, 2B
R 51, 52	0280393	39kΩ 1/3W C.R.	1B, 2B
VR01, 02	1033610	470Ω(B)Volume, DC OV	1A, B, 2A, B

Parts List

Parts No.	Stock No.	Description	Position
<b>Transistors</b>			
TR01, 02	0306071, 2	2SC1313 G, H	1A, 2A
TR03, 04	0306071, 2	2SC1313 G, H	1A, 2A
TR05, 06	0306680, 1	2SC2071 B, V	1B, 2B
TR07, 08	0301090, 1	2SA992 F, E	1B, 2B
TR09, 10	0301090, 1	2SA992 F, E	1B, 2B
<b>FET</b>			
FET01, 02	0370311, 2	2SK129 L, M	1A, 2A

Note: The circuit boards, F-2830, F-2834, F-2996, F-2832, F-2842, F-2843, F-2928, F-2836, F-2837 are not supplied as the assembled, the individual parts on the circuit board, however, are provided for orders.

3-7. F-2830 Power Supply Circuit Board for power amp section

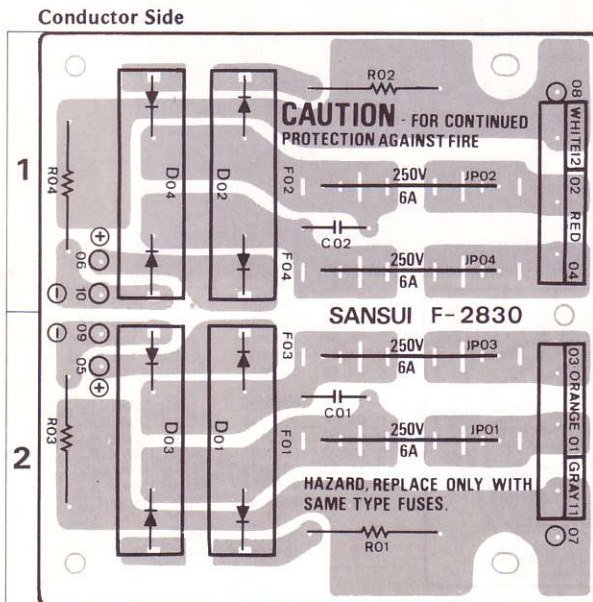

Parts List

Parts No.	Stock No.	Description	Position
<b>Diodes</b>			
D 01, 02	0311290	SS-3	2.1
D 03, 04	0311300	SS-3R	2.1
C 01, 02	0606108	0.1μF 250V M.C.	1.2
R 01, 02	0212332	3.3kΩ 2W N.I.R.	2.1
R 03, 04	0212332	3.3kΩ 2W N.I.R.	2.1
F 01, 02	0431290	6A 250V AC Fuse	2.1
F 03, 04	0431290	6A 250V AC Fuse	2.1

Abbreviations

C.R.	: Carbon Resistor	E.C.	: Electrolytic Capacitor
S.R.	: Solid Resistor	BP.E.C.	: Bi-Polar Electrolytic Capacitor
Ce.R.	: Cement Resistor	C.C.	: Ceramic Capacitor
M.R.	: Metal Film Resistor	Mi.C.	: Mica Capacitor
F.R.	: Fusing Resistor	O.C.	: Oil Capacitor
N.I.R.	: Non-Inflammable Resistor	P.C.	: Polystyrene Capacitor
M.C.	: Mylar Capacitor	T.C.	: Tantalum Capacitor

3-8. F-2834 Input Terminal Circuit Board

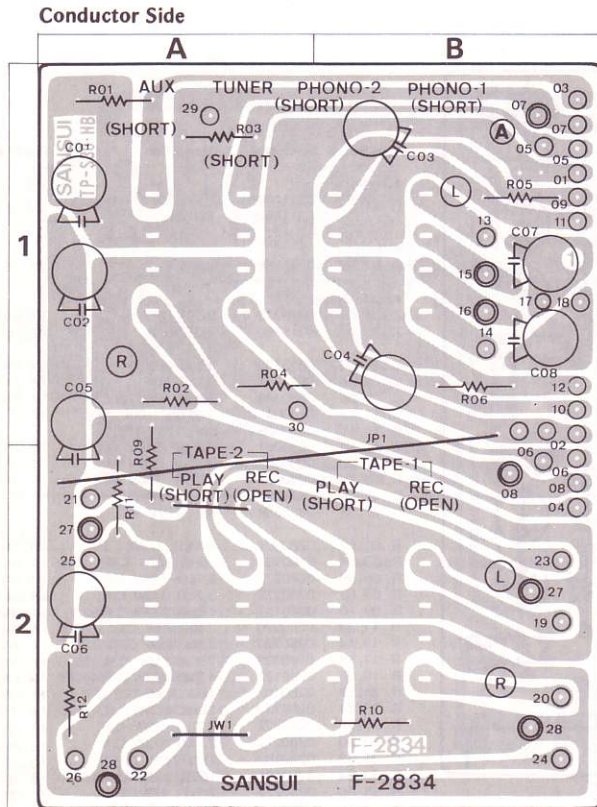

Parts List

Parts No.	Stock No.	Description	Position
R 01, 02	0280105	1M $\Omega$ 1/3W C.R.	1A
R 03, 04	0280105	1M $\Omega$ 1/3W C.R.	1A
R 05, 06	0280104	100k $\Omega$ 1/3W C.R.	1B
R 09, 10	0280105	1M $\Omega$ 1/3W C.R.	2A, 2B
R 11, 12	0280105	1M $\Omega$ 1/3W C.R.	2A
	2200620	4P Input Terminal, tuner, aux	
	2200630	4P Input Terminal, phono 1, 2	
	2200650	4P Input Terminal, tape 1, 2	

3-9. F-2996 Connection Circuit Board

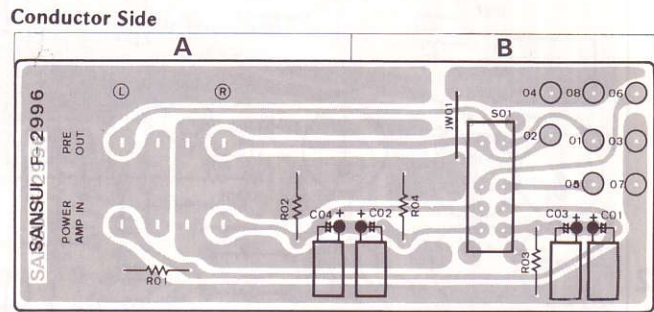

Parts List

Parts No.	Stock No.	Description	Position
R 01, 02	0280105	1M $\Omega$ 1/3W C.R.	A
R 03, 04	0280105	1M $\Omega$ 1/3W C.R.	B
S 01	1110290	Slide Switch, connected/separated	B
	2200650	4P Input Terminal, pre-out, power-in	

3-10. F-2832 Loudness, Jump, Tone Defeat Circuit Board

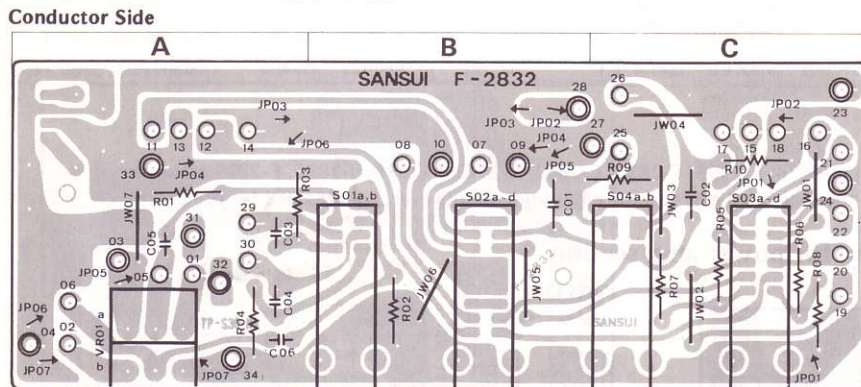

Parts List

Parts No.	Stock No.	Description	Position
C 01, 02	0680061	0.33 $\mu$ F 100V M.C.	B, C
C 03, 04	0680033	0.022 $\mu$ F 100V M.C.	A
C 05, 06	0622331	330pF 125V P.C.	A
R 01, 02	0280105	1M $\Omega$ 1/3W C.R.	A, B
R 03, 04	0280153	15k $\Omega$ 1/3W C.R.	A
R 05, 06	0280472	4.7k $\Omega$ 1/3W C.R.	C
R 07, 08	0280182	1.8k $\Omega$ 1/3W C.R.	C
R 09, 10	0280823	82k $\Omega$ 1/3W C.R.	C
VR01	1015460	250k $\Omega$ (MN) x 2 Volume, balance	A
S 01	1171130	Lever Switch, loudness	B
S 02	1171170	Lever Switch, jump	B
S 03	1171150	Lever Switch, tone defeat	C
S 04	1171130	Lever Switch, subsonic filter	C

3-11. F-2842 Tone Control Circuit Board

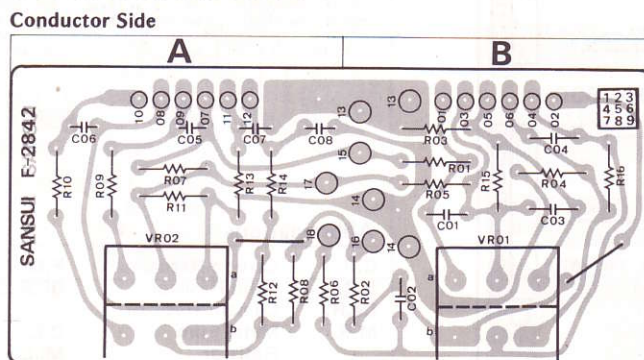

Parts List

Parts No.	Stock No.	Description	Position
C 01, 02	0680051	0.12 $\mu$ F 100V M.C.	B
C 03, 04	0680058	0.24 $\mu$ F 100V M.C.	B
C 05, 06	0680029	0.015 $\mu$ F 100V M.C.	A
C 07, 08	0680039	0.039 $\mu$ F 100V M.C.	A
C 09, 10	0680017	0.0047 $\mu$ F 100V M.C.	A
R 01, 02	0280392	3.9k $\Omega$ 1/3W C.R.	B
R 03, 04	0280152	1.5k $\Omega$ 1/3W C.R.	B
R 05, 06	0280101	100 $\Omega$ 1/3W C.R.	B, A
R 09, 10	0280681	680 $\Omega$ 1/3W C.R.	A
R 11, 12	0280472	4.7k $\Omega$ 1/3W C.R.	A
R 13, 14	0280471	470 $\Omega$ 1/3W C.R.	A
R 17, 18	0280100	10 $\Omega$ 1/3W C.R.	A
VR01	1011170	5k $\Omega$ x 2 Volume, bass	B
VR02	1011170	5k $\Omega$ x 2 Volume, treble	A

3-12. F-2843 Turn-over Circuit Board

Parts List

Parts No.	Stock No.	Description
C 01, 02	0680051	0.12μF 100V M.C.
C 03, 04	0680058	0.24μF 100V M.C.
C 05, 06	0680029	0.015μF 100V M.C.
C 07, 08	0680039	0.039μF 100V M.C.
R 01, 02	0280105	1MΩ 1/3W C.R.
R 03, 04	0280105	1MΩ 1/3W C.R.
R 05, 06	0280105	1MΩ 1/3W C.R.
R 07, 08	0280105	1MΩ 1/3W C.R.
S 01	1131410	Push Switch, tone selector

3-13. F-2928 Rectifier Circuit Board

Parts List

Parts No.	Stock No.	Description
•Diodes		
D 01	0310340	10D1
D 02	0310340	10D1
D 03	0310340	10D1
D 04	0310340	10D1
C 01	0606108	0.1μF 250V M.C.
R 01	0211100	10Ω 1W N.I.R.
F 01	0431220	1A 250V AC Fuse
F 02	0432290	5A 125V AC Fuse
	0434060	10A 250V AC Fuse

3-14. F-2836 Tape Playback Circuit Board

Parts List

Parts No.	Stock No.	Description
S 01	1131400	Push Switch, play

3-15. F-2837 Tape-copy Switch Circuit Board

Parts List

Parts No.	Stock No.	Description
	1102750	Rotary Switch, tape rec

4. OTHER PARTS

4-1. Front View

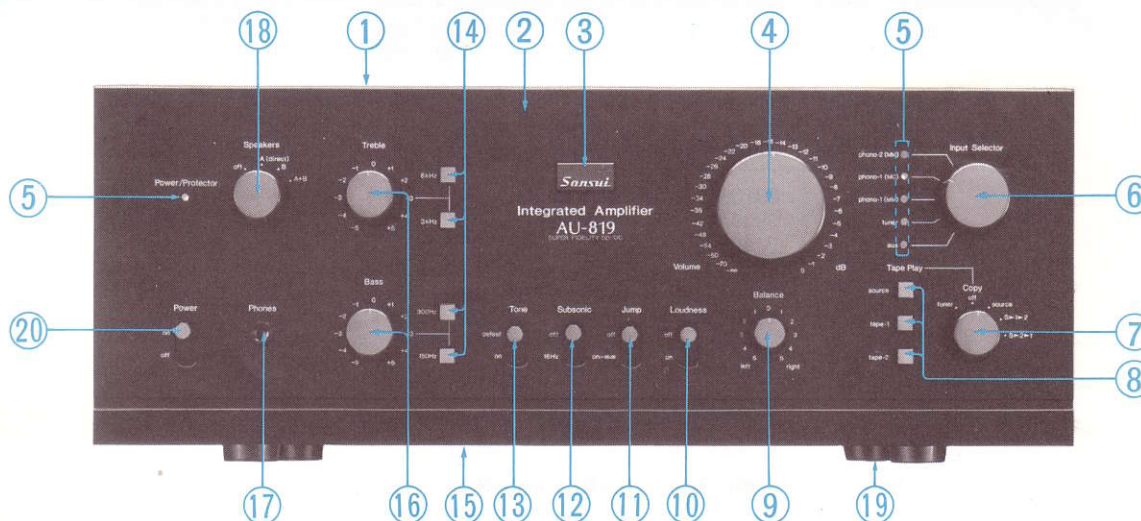

Parts List

Parts No.	Stock No.	Description	Parts No.	Stock No.	Description	Parts No.	Stock No.	Description
1	5006780	Bonnet	7	5318840	Tape Copy Knob	13	5326612	Lever Switch Knob
2	7008060	Front Panel Ass'y		1102750	Rotary Switch, tape copy		1171150	Lever Switch, tone defeat
	0319190	Light Emitting Diode		5326620	Push Switch Knob	14	5326620	Push Switch Knob
	5048221	Masking Sheet	8	5286721	Knob Guide		1131410	Push Switch, turn-over
	5152210	CS Ling		1131400	Push Switch		5318840	Tone Volume Knob
	5286721	Knob Guide	9	5318850	Balance Volume Knob		1011170	100kΩ (C) x 2 Treble & Bass Volume
	5326620	Push Switch Knob		1015460	250kΩ (MN) x 2 Balance Volume	16	1011170	100kΩ (C) x 2 Treble & Bass Volume
3	5336600	Sansui Badge	10	5326612	Lever Switch Knob	17	2430290	Headphone Jack
	5318861	Volume Knob		1171130	Lever Switch, loudness	18	5318840	Speaker Selector Knob
4	1090430	150kΩ x 2 Volume	11	5326612	Lever Switch Knob		1101900, 1	Rotary Switch, speaker
	1090450	150kΩ x 2 Volume		1171170	Lever Switch, jump	19	5507070	Leg
5	0319110	Light Emitting Diode	12	5326612	Lever Switch Knob		5326612	Lever Switch Knob
6	5318830	Selector Knob		1171130	Lever Switch, subsonic	20	1171630	Lever Switch, power
	1104380	Rotary Switch, input selector						

4-2. Top View

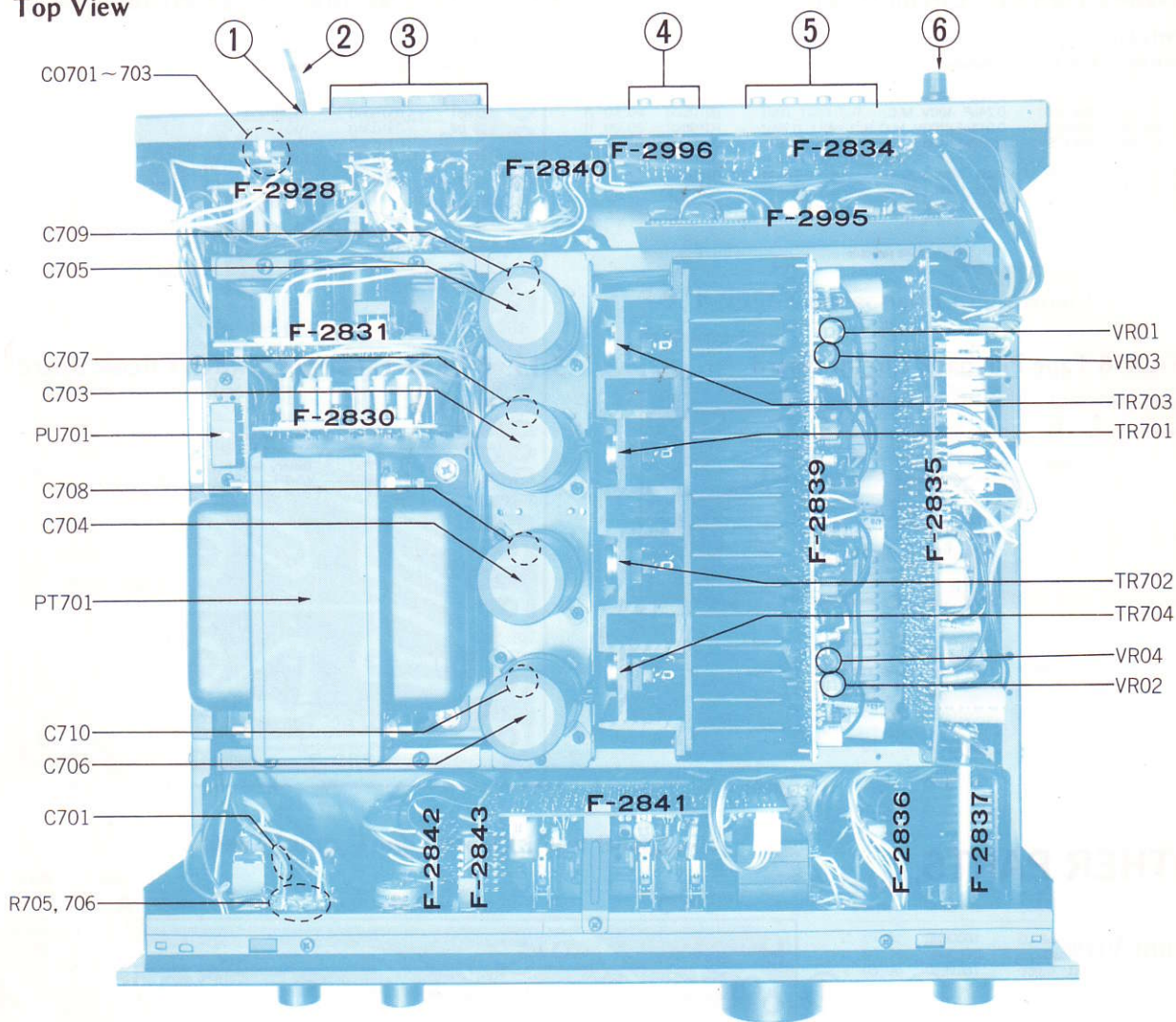

Parts List

Parts No.	Stock No.	Description
1	2910600	Strain Relief
2	3800470	Power Cord
3	2290190	Speaker Terminal
4	2200650	4P Input Terminal, pre-out, power-in
	2200620	4P Input Terminal, tuner, aux
5	2200630	4P Input Terminal, phono-1, 2
	2200650	4P Input Terminal, tape-1, 2
6	2230190	Ground Terminal
TR 701, 702	0306770, 1	NMC1216 O, Y
TR 703, 704	0301120, 1	NMA1216 O, Y
R 701 ~ 704	0159130	0.33Ω 5W Ce.R.
C 701	0659801	0.01μF 150V C.C.
C 703 ~ 706	0559520	15000μF 63V E.C.
C 707 ~ 710	0681003	1μF 250V M.C.
R 705, 706	0202221	220Ω 2W N.I.R.
C0701~703	2450070	AC Outlet
PT 701	4002910	Power Transformer
PU 701	2410091	Voltage Selector Plug
	2410830	Voltage Selector Socket

5. SCHEMATIC DIAGRAM 5-1. Pre/Main Section

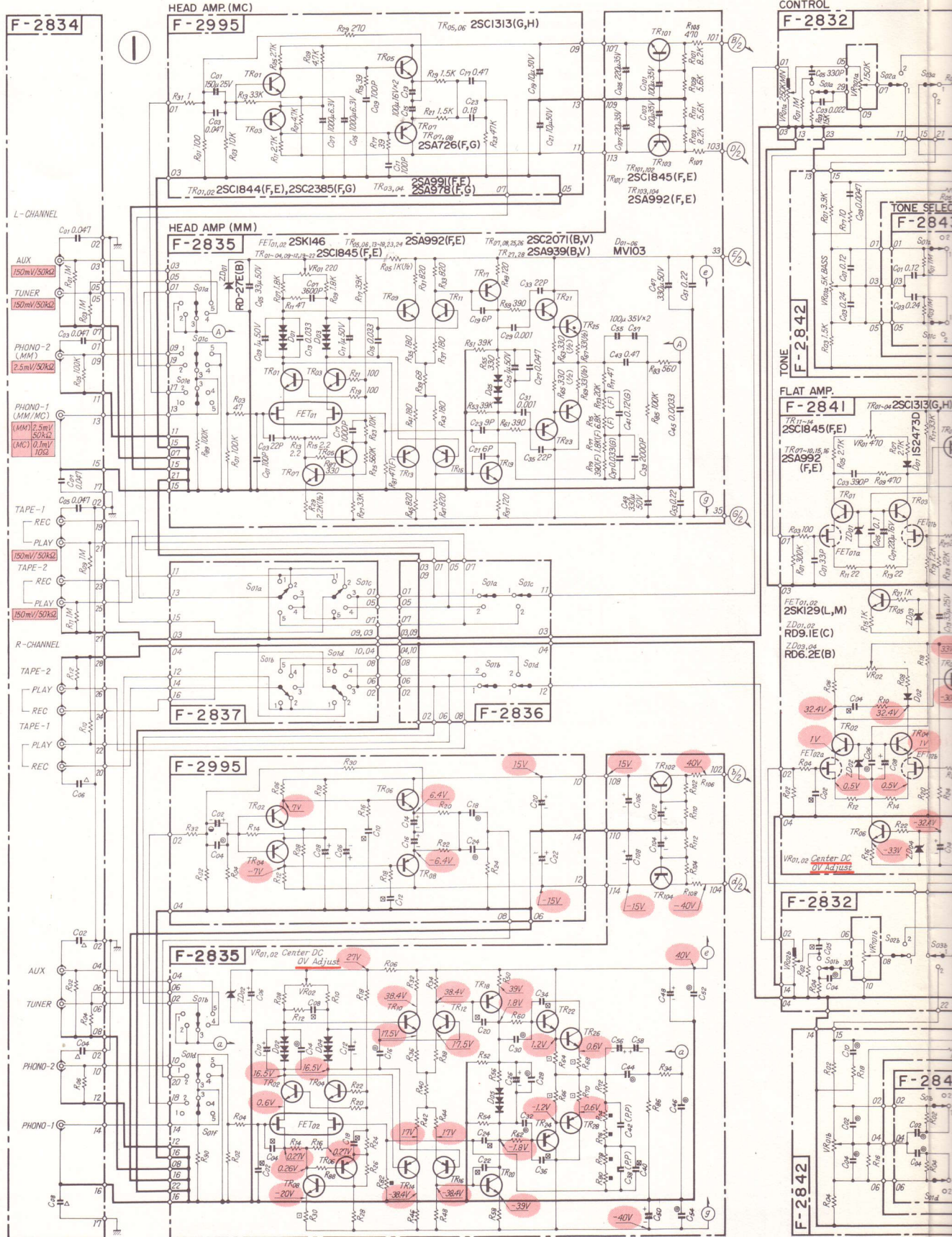

CONTROL F-2832

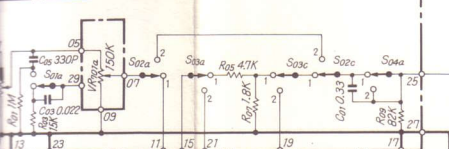

F-2842

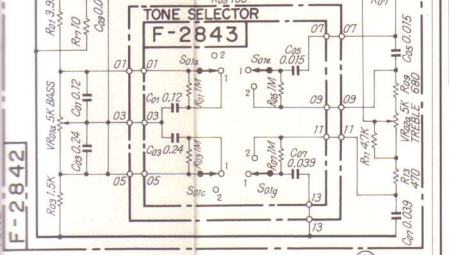

AT AMP. F-2841

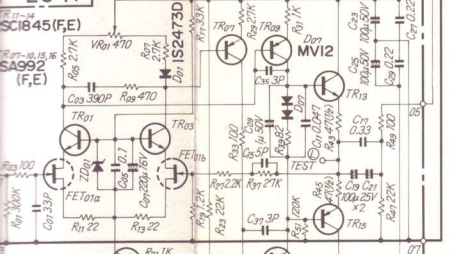

F-2832

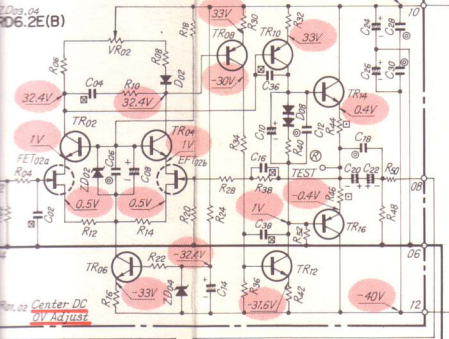

F-2832

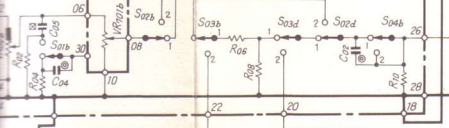

F-2842

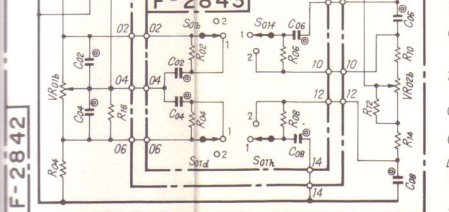

SWITCHES F-2996

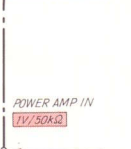

F-2835

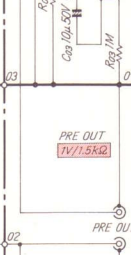

F-2835

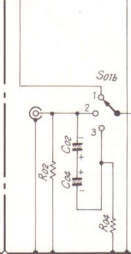

F-2835

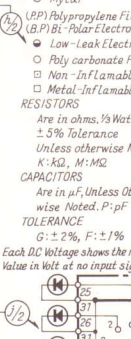

F-2835

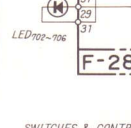

SWITCHES & CONTROLS

- Selector F-2835 (S01a-g)
  1. phono - 2
  2. phono - 1 MC
  3. phono - 1 MM
  4. tuner
  5. aux
- Tape rec F-2837 (S01a-d)
  1. tuner
  2. off
  3. source
  4. S 1 > 2
  5. S 2 > 1
- Tape play F-2836 (S01a)
  1. source
  2. tape 1
- (S01a-d)
  1. source
  2. tape 2
- Loadness F-2832 (S01)
  1. off
  2. on
- Jump F-2832 (S02)
  1. off
  2. on (-16dB)
- Tone F-2832 (S02)
  1. defeat
  2. on
- Subsonic F-2832 (S04)
  1. off
  2. 16Hz
- Tone selector F-2843 (S01a-d)
  1. 300Hz
  2. 150Hz
  - TREBLE
- (S01a-d)
  1. 3kHz
  2. 6kHz
- Pre-power F-2996
  1. CONNECTED
  2. DIRECT COUPLED
  3. CAPACITOR COUPLED
- Speakers (S01)
  1. off
  2. A (direct)
  3. B
  4. A+B
- Power (S02)
  1. off
  2. on

DRIVER F-2839

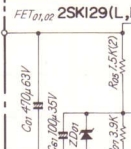

F-2839



F-2839

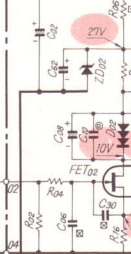

F-2839

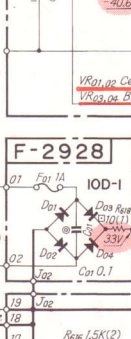

F-2839

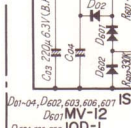

F-2839

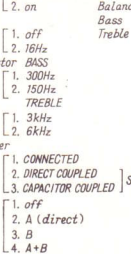

DRIVER F-2839

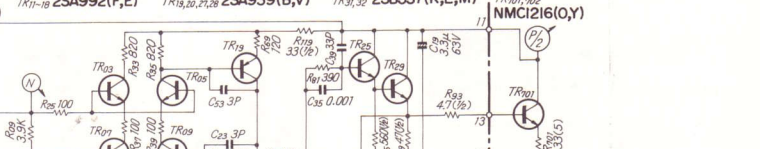

F-2839

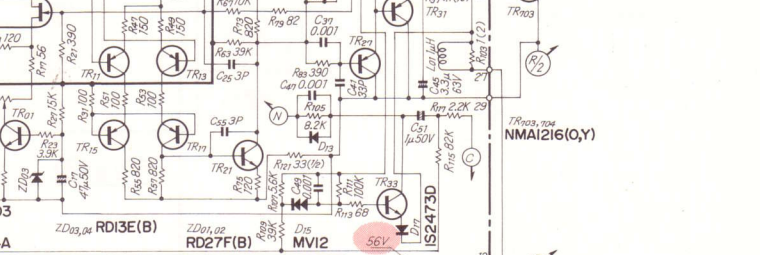

F-2839

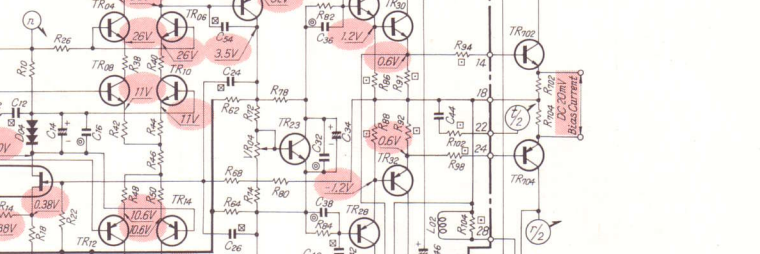

F-2839

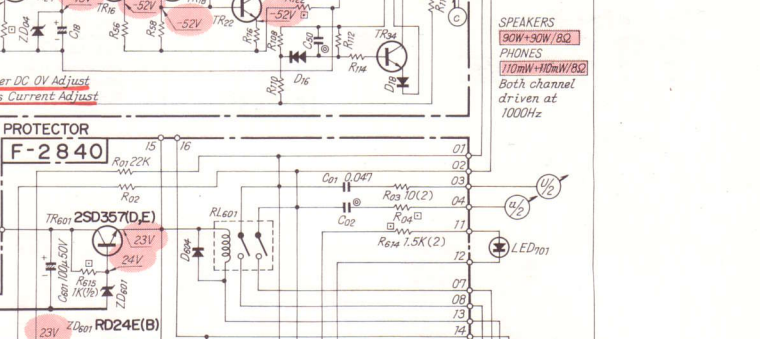

F-2839

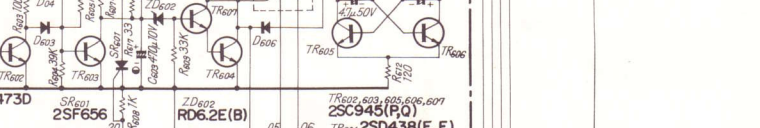

F-2839

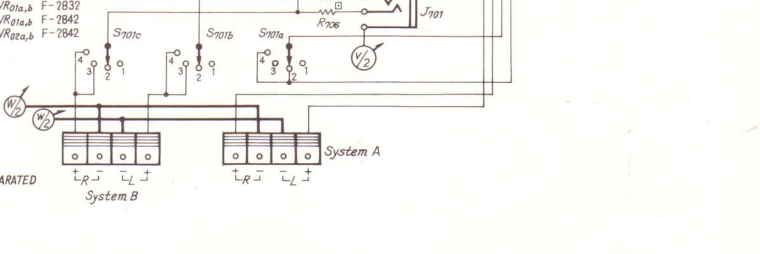

SPEAKERS 90W+90W BQ PHONES 1700W+1700W BQ Both channel driven at 1000Hz

1

2

3

4

5

10



## 6. PACKING LIST

Parts No.	Stock No.	Description
1	9116770	Vinyl Cover
2	9028250	Styrofoam Packing (R)
3	9028240	Styrofoam Packing (L)
4	9001530	Carton Case
5	5996080	Curl Stopper

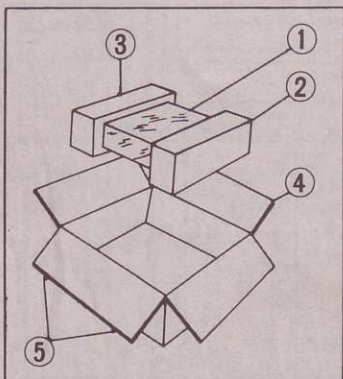

## 7. ACCESSORY PARTS LIST

Stock No.	Description
9204180	Operating Instructions
9237980	Schematic Diagram
5396340	Rack-mounting Adaptor (ea.)

MEMO



SANSUI ELECTRONICS CORPORATION: 55-11 Queens Blvd. Woodside, N.Y. 11377 U.S.A.  
 333 West Alondra Blvd. Gardena, California 90247 U.S.A.  
 3036 Koapaka St. Honolulu, Hawaii 96819 U.S.A.

SANSUI AUDIO EUROPE N.V.: North Trade Bldg (9th floor) Noorderlaan 133-Bus 1,2030 Antwerp, Belgium  
 SANSUI AUDIO EUROPE S.A.: Arabella center, 6 Frankfurt AM Main, Lyoner Strasse 44-48, West Germany

SANSUI ELECTRIC COMPANY LTD.: 14-1, Izumi 2-chome, Suginamiku, Tokyo 168 Japan PHONE: (03) 323-1111/TELEX:232-2076