

SERVICE MANUAL

AUDIO VIDEO PROCESSOR

SANSUI AV-77



CAUTION

1. Parts identified by the \triangle symbol on the schematic diagram and the parts list are critical for safety. Use only replacement parts that have critical characteristics recommended by the manufacturer.
2. Make leakage-current or resistance measurements to determine that exposed parts are acceptably insulated from the supply circuit before returning the appliance to the customer.

•SPECIFICATIONS

Video section

VIDEO INPUT sensitivity/Impedance

..... 1.0 Vp-p/75 ohms

VIDEO OUTPUT level/Impedance

..... 1.0 Vp-p/75 ohms

Signal-to-noise ratio (video signal)

VCR A, VCR B, VDP → VIDEO

OUTPUT 62 dB

Frequency response (video signal)

..... 6.5 Hz ~ 10 MHz - 3 dB

AUDIO INPUT sensitivity/Impedance

..... -6 dBs/47 kohms

AUDIO OUTPUT level/Impedance

..... -6 dBs/47 kohms

Signal-to-noise ratio (IHF-A)

VCR B, VDP → VCR A OUTPUT

..... Better than 80 dB

VCR A, VCR B, VDP → AUDIO

OUTPUT Better than 80 dB

Frequency response

VCR B, VDP → VCR A OUTPUT

..... 20 Hz ~ 100 kHz - 3dB

VCR A, VCR B, VDP → AUDIO

OUTPUT 20 Hz ~ 100 kHz - 3 dB

VHF OUT signal 3 ch or 4 ch

Audio section

Input sensitivity/Impedance

AUDIO INPUT, TAPE PLAY

..... 150 mV/47 kohms

MIC 0.5 mV/10 kohms

Signal-to-noise ratio

AUDIO INPUT, TAPE PLAY →

AUDIO OUTPUT... Better than 80 dB

MIC → AUDIO OUTPUT

..... Better than 50 dB

Frequency response

AUDIO INPUT, TAPE PLAY →

AUDIO OUTPUT... 10 Hz ~ 100 kHz - 3 dB

Output level/Impedance..

150 mV/2.2 kohms

Maximum output level

1V

Total harmonic distortion

AUDIO INPUT, TAPE PLAY →

AUDIO OUTPUT... Less than 0.08% at 1 kHz

dbx noise reduction effect -30 dB at 1 kHz

NOISE FILTER..... 3 kHz -6 dB/oct

Others

Power requirements 120/220/240V

50/60 Hz

For U.S.A. and Canada

..... 120V (60 Hz)

Power consumption 33 watts (with camera)

Dimensions 430 mm (16-15/16")W

76 mm (3")H

265 mm (10-7/16")D

Weight 3.7 kg (8.2 lbs) net

4.6 kg (10.1 lbs) packed

* Design and specifications subject to changes without notice for improvements.
 * In order to simplify the explanation illustrations may sometimes differ from the originals.



SANSUI ELECTRIC CO., LTD.

CAUTION

1. The symbols, UL, CSA, SA, BS, UK, EU, AS and XX (EXPORT) on the parts list and the schematic diagram mean followings respectively.
 - UL..... Manufactured for U.S.A market.
(Underwriters Laboratories approved model.)
 - CSA Manufactured for Canadian market.
 - SA..... Manufactured for South African market.
 - BS, UK Manufactured for United Kingdom market.
 - EU Manufactured for European market.
 - AS..... Manufactured for Australian market.
 - XX (EXPORT) Standard Version.
 - NON MARK Common Parts.

2. Some printed circuit boards are not supplied as the assembled. To separate these in this service manual, the stock No's are not indicated at the ends of the board names. However, the individual parts on the circuit boards are provided by orders.

3. Since some of capacitors and resistors are omitted from parts lists in this service manual, refer to the Common Parts List for capacitors & resistors, which was issued on February 1983.

4. Abbreviations in this service manual are as follows.

•Abbreviations List

| | |
|---|--|
| C.R. : Carbon Resistor | E.B.L. : Low Leak Bi-Polar Electrolytic Capacitor |
| S.R. : Solid Resistor | Ta.C. : Tantalum Capacitor |
| Ce.R. : Cement Resistor | F.C. : Film Capacitor |
| M.R. : Metal Film Resistor | M.P. : Metalized Paper Capacitor |
| F.R. : Fusing Resistor | P.C. : Polystyrene Capacitor |
| N.i.R. : Non-Inflammable Resistor | G.C. : Gimmic Capacitor |
| A.R. : Array Resistor | A.C. : Array Capacitor |
| C.C. : Ceramic Capacitor | V.R. : Variable Resistor |
| C.T. : Ceramic Capacitor, Temperature Compensation | S.V.R. : Semi Variable Resistor |
| E.C. : Electrolytic Capacitor | SW. : Switch |
| E.L. : Low Leak Electrolytic Capacitor | Chip R. : Chip Resistor |
| E.B. : Bi-Polar Electrolytic Capacitor | Chip C. : Chip Capacitor |

1. BLOCK DIAGRAM

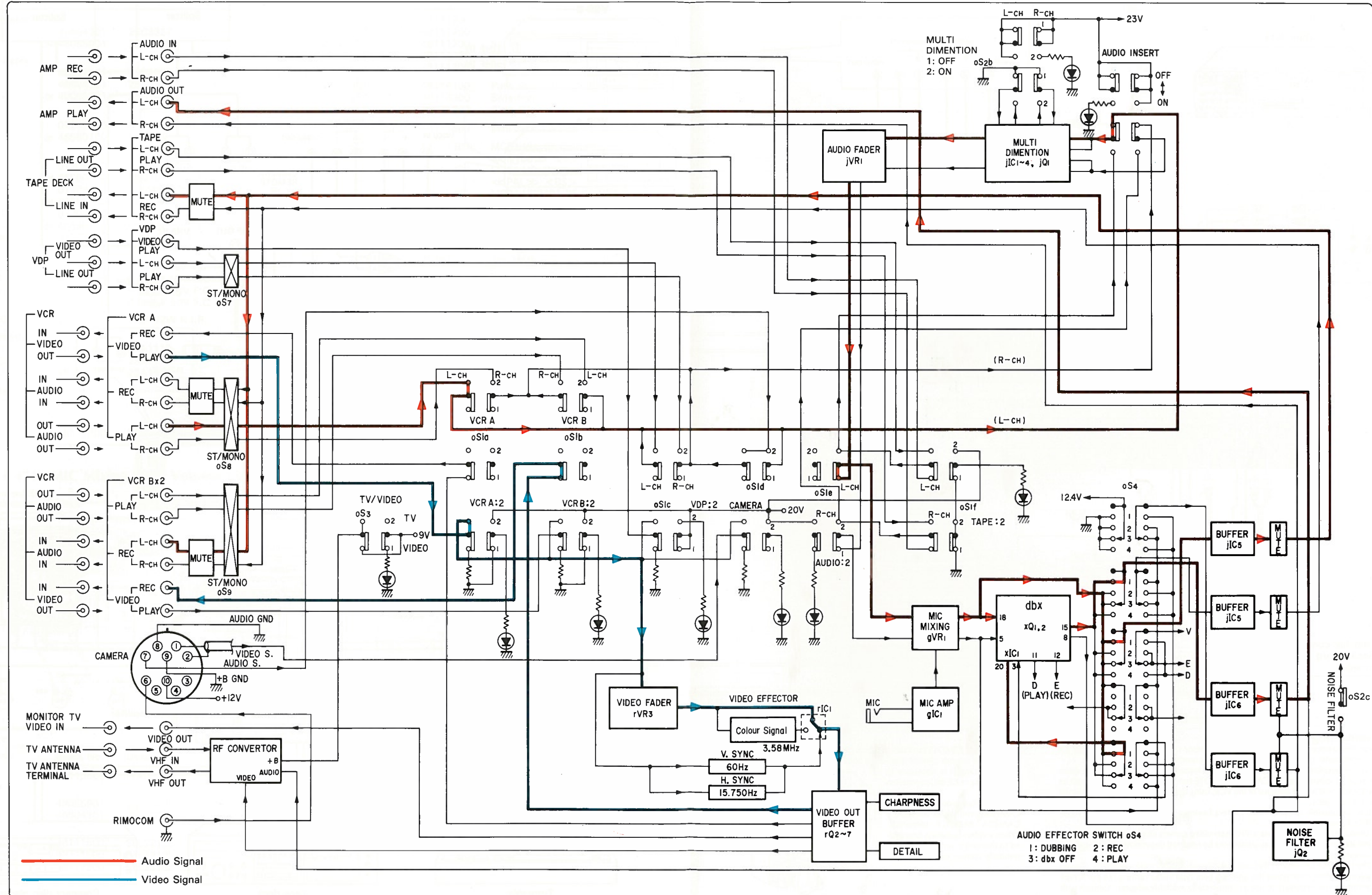

2. CONNECTION DIAGRAM

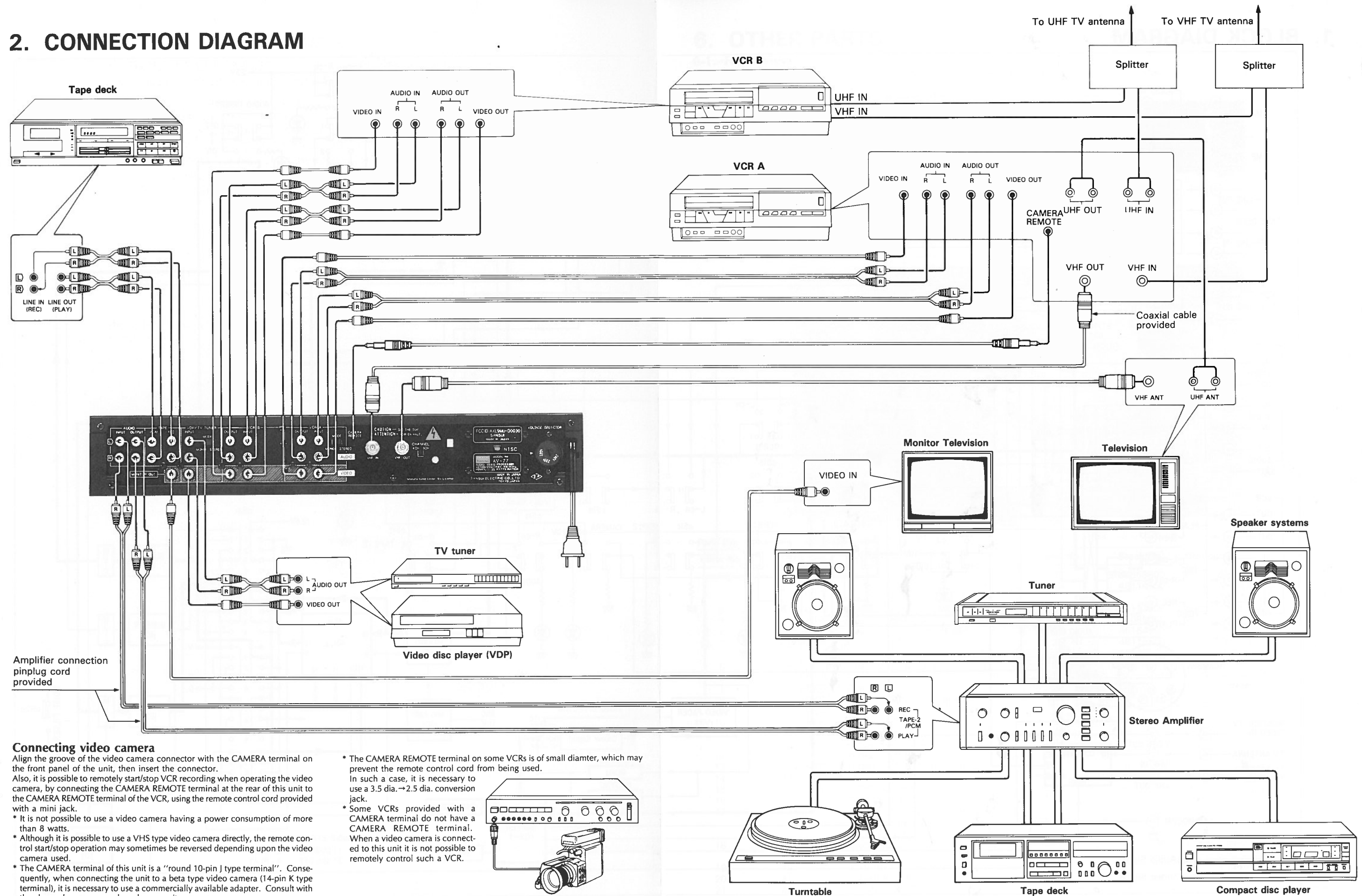

Connecting video camera

Align the groove of the video camera connector with the CAMERA terminal on the front panel of the unit, then insert the connector.

Also, it is possible to remotely start/stop VCR recording when operating the video camera, by connecting the CAMERA REMOTE terminal at the rear of this unit to the CAMERA REMOTE terminal of the VCR, using the remote control cord provided with a mini jack.

* It is not possible to use a video camera having a power consumption of more than 8 watts.

* Although it is possible to use a VHS type video camera directly, the remote control start/stop operation may sometimes be reversed depending upon the video camera used.

* The CAMERA terminal of this unit is a "round 10-pin J type terminal". Consequently, when connecting the unit to a beta type video camera (14-pin K type terminal), it is necessary to use a commercially available adapter. Consult with the shop where you purchased your unit.

* The CAMERA REMOTE terminal on some VCRs is of small diameter, which may prevent the remote control cord from being used.

In such a case, it is necessary to use a 3.5 dia. → 2.5 dia. conversion jack.

* Some VCRs provided with a CAMERA terminal do not have a CAMERA REMOTE terminal. When a video camera is connected to this unit it is not possible to remotely control such a VCR.

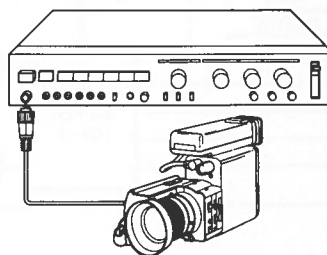

3. OPERATION

A. dbx System Operation

•Configuration and Principle

The dbx system accurately compresses signals to be recorded to half in logarithmic value before the signals are inputted to a recording system and expands the compressed signals to double when the signals are played back. For instance, in the case where a program source has a dynamic range of 100 dB, the source is compressed to 50 dB in recording, as shown in Fig. 3-1. Therefore, if the dynamic range of a cassette deck is 60 dB, it is possible to record the abovementioned program source perfectly. On the other hand, the recorded signals are returned to music signals having a dynamic range of 100 dB when played back. The system serves to reduce noise. That is, since the recording level is raised beyond hiss noise level generated in recording, it is possible to improve the noise level as much as about 30 dB or more throughout the total frequency bandwidth.

The system is configured as shown in Fig. 3-2.

•Each section operation

1) Pre-emphasis and De-emphasis circuits

The pre-emphasis operation is to raise high-frequency signals in order to reduce noise modulation effect (noise breathing) of high-frequency

Fig. 3-1

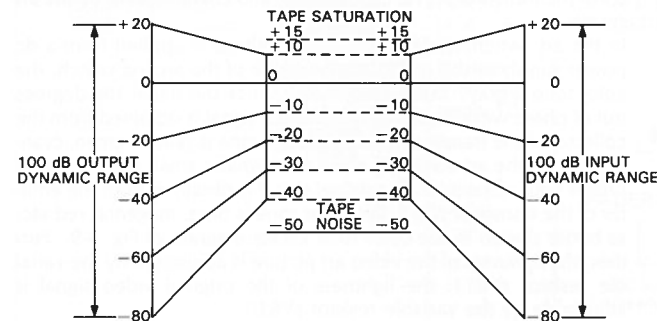

B. Phase Response of Multi Dimension Circuit

Fig. 3-3

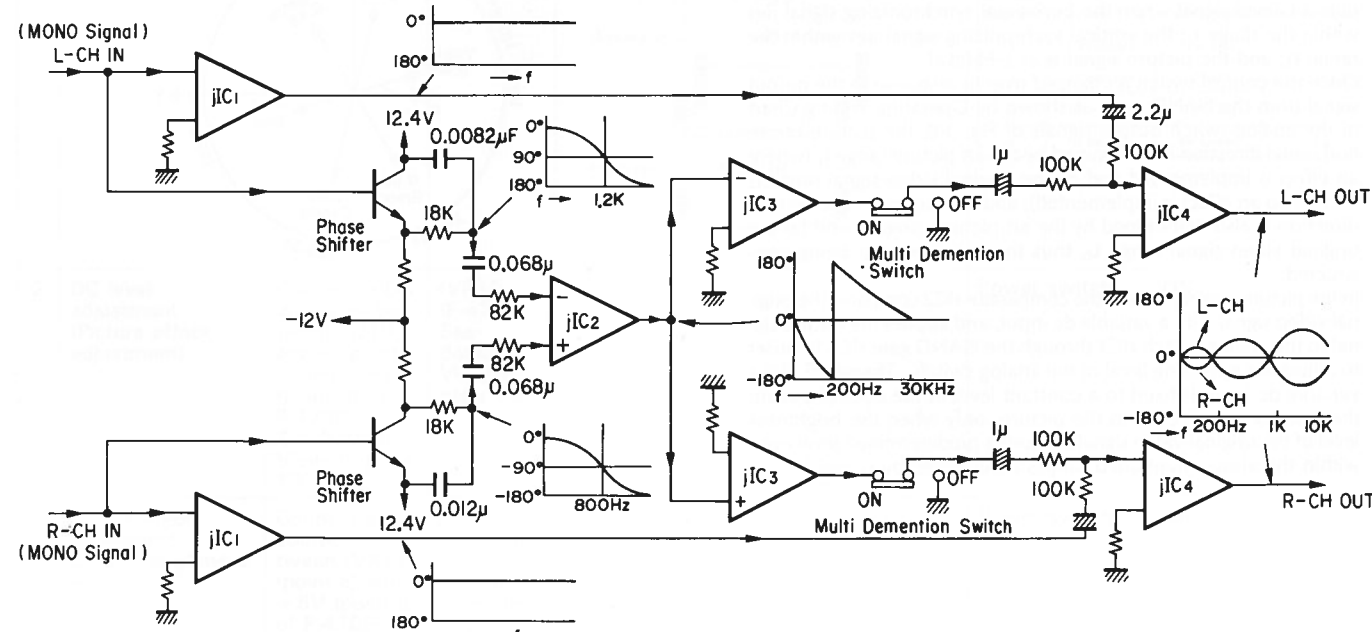

•When used on stereo programs, speeds sound even more than normal with mono programs, create a lated stereo effect.

signals in recording. On the other hand, the de-emphasis operation is to lower the raised high-frequency signals in order to return the frequency characteristics to the flat state in playing back, therefore the characteristics of de-emphasis being complementary to those of pre-emphasis.

2) VCA (voltage controlled amplifier or attenuator)

In this amplifier, the amplification degree changes linearly and logarithmically according to a dc control voltage applied externally. Therefore, it is possible to compressor expand an input signal dynamic range within a wide range in dependence upon the characteristics of the voltage controlled amplifier.

3) Waiting network

This network is provided at the front stage of a level sensor in order to prevent tape recording saturation. In the network, the gain of encoder VCA is reduced with respect to high-frequency input signals.

4) Root Mean Square Value (RMS) level sensor

This sensor detects the effective value of input signal and outputs a dc control voltage proportional to the detected level in order to control the gain of VCA according to the level of the input signal.

Fig. 3-2

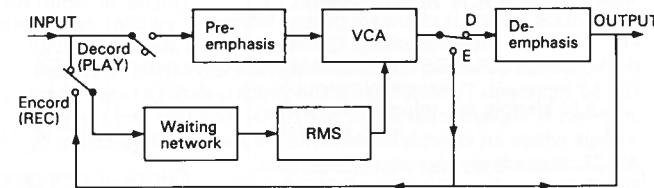

"dbx" is a trademark of DBX Incorporated. DBX noise reduction system manufactured under license from DBX Incorporated.

C. Video Effector Operation

1. Video Effector Block Diagram

Fig. 3-4

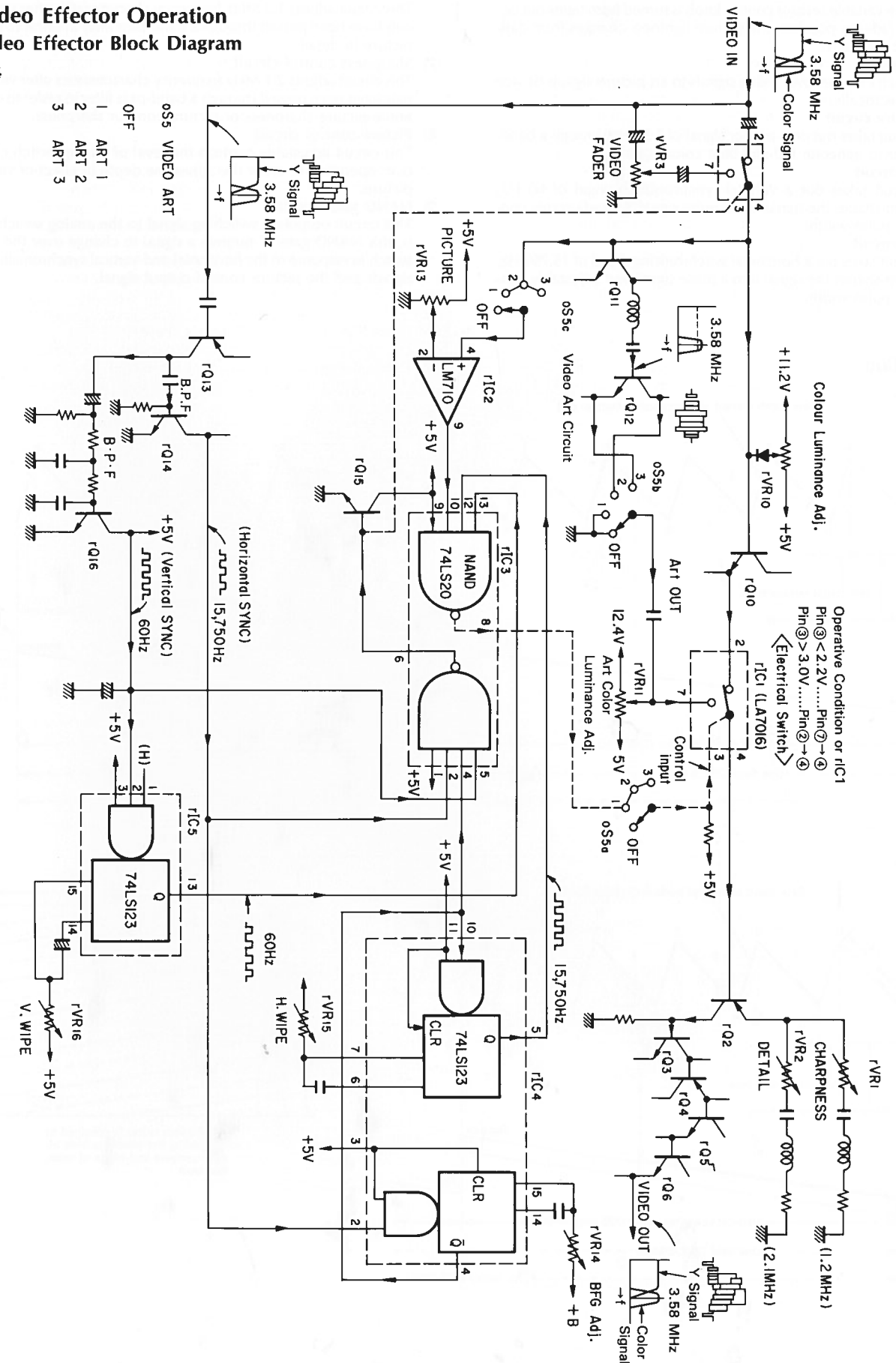

2. Circuit Configuration (See Fig. 3-4)

- 1) **Fader control**
When the variable resistor control knob is turned from fader-out position to fader-in position, the picture lightness changes from dark to bright gradually.
- 2) **Analog switch**
This switch changes over video signals to art picture signals or vice versa, electrically.
- 3) **Art picture circuit**
This circuit takes out only a color signal of 3.58 Hz through a band-pass filter to generate red-and-blue color signals.
- 4) **V-hold circuit**
This circuit takes out a vertical synchronizing signal of 60 Hz, waveform-shapes the signal into a pulse signal, and adjustably controls the pulse width.
- 5) **H-hold circuit**
This circuit takes out a horizontal synchronizing signal of 15.750 Hz, waveform-shapes the signal into a pulse signal and adjustably controls the pulse width.
- 6) **Detail control circuit**
This circuit adjusts 1.2 MHz frequency characteristics after video signals have been passed through a band-pass filter in order to control picture in detail.
- 7) **Sharpness control circuit**
This circuit adjusts 2.1 MHz frequency characteristics after video signals have been passed through a band-pass filter in order to control entire-picture sharpness or picture contour sharpness.
- 8) **Picture control circuit**
This circuit adjustably controls the level of analog-switch change-over operation in order to adjust the depth in effect of video art picture.
- 9) **NAND gate circuit**
This circuit outputs a switching signal to the analog switch. That is, this NAND gate IC outputs a signal to change over the analog switch in response to the horizontal-and-vertical synchronizing pulse signals and the picture control output signal.

3. Operation

Fig. 3-5

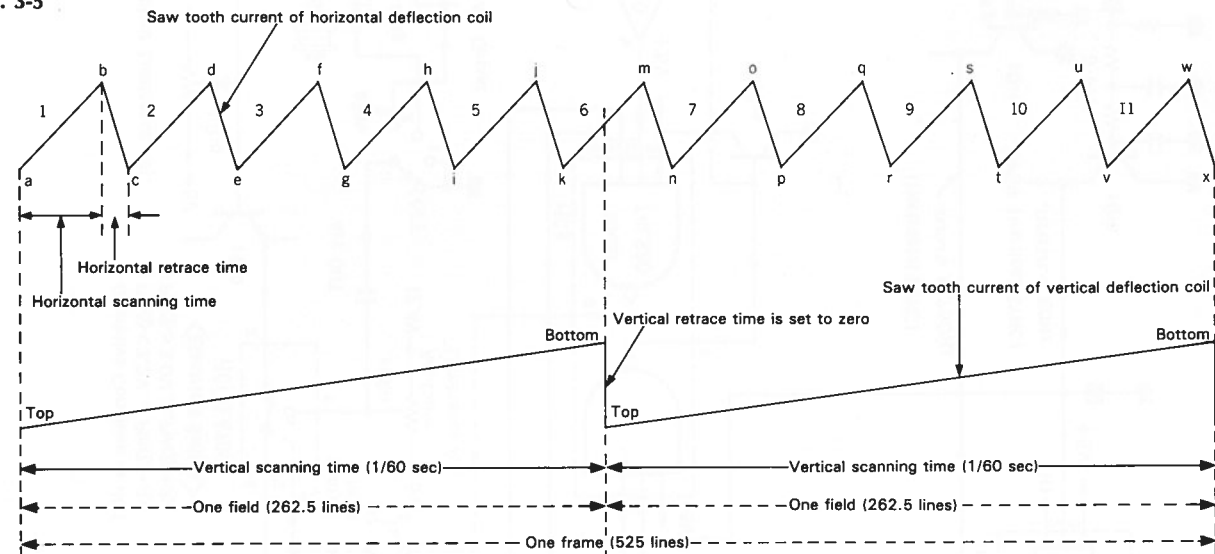

Fig. 3-6

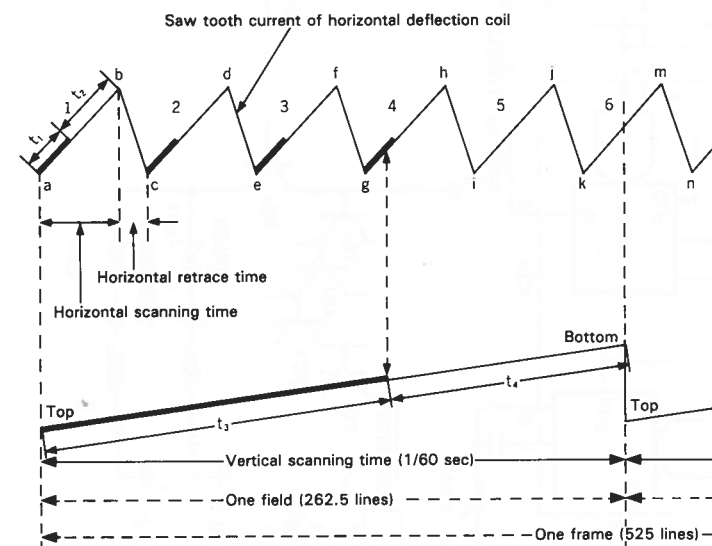

Fig. 3-7

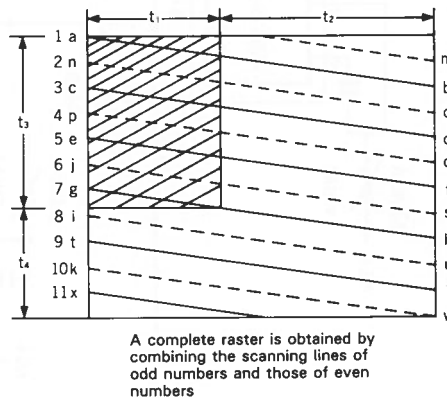
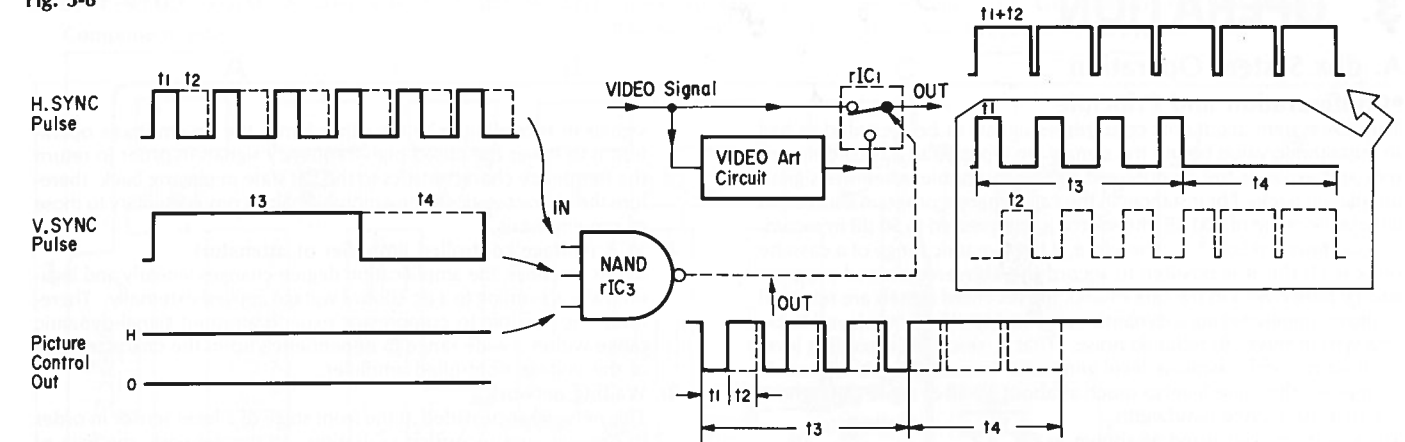

Fig. 3-8



1) How to Determine Video-art Effect Range

In Fig. 3-4, the analog switch rIC1 is connected to the video art circuit in response to a L-level NAND gate control signal and to the original video signals in response to a H-level NAND gate control signal.

This analog switch is changed over as follows:

Fig. 3-5 shows the relationship between currents flowing through the horizontal deflection coil and through the vertical deflection coil. Fig. 3-7 represents TV scanning lines, in which t_1 shows a range where art effect is implemented in the horizontal direction and t_3 shows a range where art effect is implemented in the vertical direction by AV-77, respectively, by way of example.

Fig. 3-6 shows a part of Fig. 3-5, in which art-effect ranges are represented by t_1 and t_3 and no art-effect ranges are represented by t_2 and t_4 .

As depicted by Figs. 3-4 and 3-8, the analog switch control signal is outputted from pin No.8 of the NAND gate rIC3. The signals applied to the input terminals of the NAND gate are three of a horizontal synchronizing pulse signal (15.750 Hz), the pulse width of which is adjustable by the H-WIPE control knob; a vertical synchronizing pulse signal (60 Hz), the pulse width of which is adjustable by the V-WIPE control knob; and picture signals. The NAND gate outputs a L-level signal when the horizontal synchronizing signal lies within the range t_1 ; the vertical synchronizing signal lies within the range t_3 ; and the picture signal is at a H-level.

Once the control switch is changed over in response to the output signal from the NAND gate, as shown by Operating Timing Chart of the analog-switch output signals of Fig. 3-8, the picture in the horizontal direction is determined by the art picture range t_1 (where art effect is implemented and by the original video signal range t_2 (where no art effect is implemented); and the picture in the vertical direction is also determined by the art picture range t_3 and by the original video signal range t_4 , thus the entire picture being constructed.

In the picture control circuit, the comparator rIC2 compares the original video signal with a variable dc input, and applies the output signal to the analog switch rIC1 through the NAND gate rIC3 in order to adjust the operating level of the analog switch. Therefore, if the variable dc input is fixed to a constant level in the control circuit, the video art is effective to the picture, only when the brightness level of the original video signal exceeds a predetermined level even within the above-mentioned ranges determined by t_1 and t_3 .

2) Video Art Circuit Operation

In the video circuit shown in Fig. 3-4, the color signal is taken out from the original video signal through a band-pass filter of 3.58 MHz. Then, the color signal is taken out from the collector and the emitter of the transistor rQ12, respectively, and changed over by the art switch.

In the art switch 1, since a constant voltage is applied from a dc power supply to the art video signal side of the analog switch, the color tone is gray. In the art switch 2, since the signal 180 degrees out of phase with respect to the original signal is obtained from the collector of the transistor rQ12, the color tone is yellow, green, cyanic, etc. In the art switch 3, since the signal a small degree out of phase with respect to the original signal is obtained from the emitter of the transistor rQ12, the color tone is blue, magenta, red etc, as better shown in the color tone vector diagram of Fig. 3-9. Further, the lightness of the video art picture is adjustable by the variable resistor rVR11; the lightness of the original video signal is adjustable by the variable resistor rVR10.

Fig. 3-9

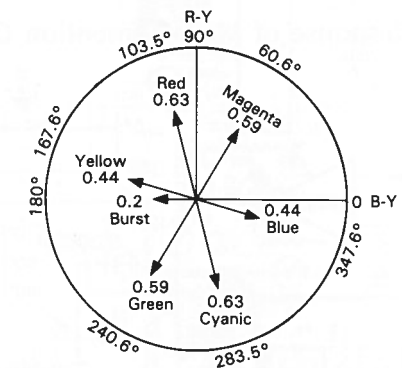

4. ADJUSTMENT

A. dbx Time Constant Adjustment

| Adjustment Procedure | Checked Position | Adjusted Parts | Adjustment Contents | Adjusting Conditions |
|--------------------------------|--|---|---------------------|----------------------|
| 1 dbx time constant adjustment | Connect a DC voltmeter across time constant test pin (points a and b) of board F-4709. (See Bottom View on page 13.) | xVR1 (F-4709) (See Bottom View on page 13.) | DC 15 ± 0 mV | dbx switch REC |

B. Video Effector Adjustment

•Required Test Equipments

1. VHS Type Video Cassette Recorder (VCR) for NTSC or PAL system
2. Test Tape MH-1 or MH-2
3. Monitor TV (or Home TV with RF Tuner)

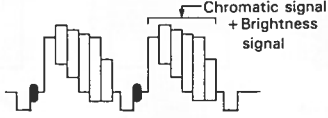
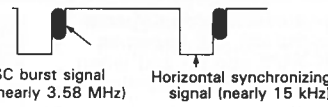
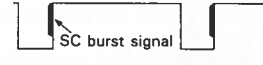
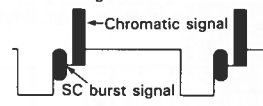
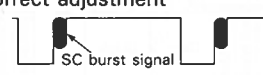
| Adjustment Procedure | Checked Position | Adjusted Parts | Adjustment Contents | Adjusting Conditions | | | | | | | | | | | | | | | | | | | | | | | | | | | | | | | | | | | | | | | | |
|--|--|--|--|--|---------|---------------|--------------|--------------|---|------------|-----------|-------|---|-----------|--------|-------|---|------------|-----------|-------|---|-----------|----------|--------|---------|---------------|--------------|--------------|---|------------|-----------|-------|---|-----------|--------|-------|---|------------|-----------|------------|---|-----------|----------|--------|
| 1 Burst Flag Gate (BFG) adjustment | Connect an oscilloscope to video monitor terminal. (The output terminal is at 75 ohms at its end.) | rVR14 (F-4706) See Bottom View on page 13. | <p>1. Check that waveforms in VIDEO FADER-IN should be as follows:</p>  <p>2. Check that waveforms in VIDEO FADER-OUT should be as follows:</p>  <p>3. Turn rVR14 to adjust SC burst signal as shown.</p> <p>•Maladjustment (Excessive turning of rVR14 clockwise)</p>  <p>(Excessive turning of rVR14 counterclockwise)</p>  <p>•Correct adjustment</p>  | <p>1. Connect VCR to VCR A VIDEO IN terminal.</p> <p>2. VIDEO ART OFF</p> <p>3. SHARPNESS, DETAIL Full counterclockwise</p> <p>4. Reproduce color bar signals of a test tape by VCR.</p> <p>•NTSC System test tape _____ MH-1 (Standard Play) Stock No. 36805000</p> <table border="1"> <thead> <tr> <th>Segment</th> <th>Playback Time</th> <th>Video Signal</th> <th>Audio Signal</th> </tr> </thead> <tbody> <tr> <td>1</td> <td>10 minutes</td> <td>Stairstep</td> <td>7 kHz</td> </tr> <tr> <td>2</td> <td>5 minutes</td> <td>(none)</td> <td>3 kHz</td> </tr> <tr> <td>3</td> <td>10 minutes</td> <td>Color bar</td> <td>1 kHz</td> </tr> <tr> <td>4</td> <td>3 minutes</td> <td>RF sweep</td> <td>(none)</td> </tr> </tbody> </table> <p>•PAL System test tape _____ MH-2 Stock No. 36809300</p> <table border="1"> <thead> <tr> <th>Segment</th> <th>Playback Time</th> <th>Video Signal</th> <th>Audio Signal</th> </tr> </thead> <tbody> <tr> <td>1</td> <td>10 minutes</td> <td>Stairstep</td> <td>6 kHz</td> </tr> <tr> <td>2</td> <td>5 minutes</td> <td>(none)</td> <td>3 kHz</td> </tr> <tr> <td>3</td> <td>10 minutes</td> <td>Color bar</td> <td>1 kHz 0 dB</td> </tr> <tr> <td>4</td> <td>3 minutes</td> <td>RF sweep</td> <td>(none)</td> </tr> </tbody> </table> | Segment | Playback Time | Video Signal | Audio Signal | 1 | 10 minutes | Stairstep | 7 kHz | 2 | 5 minutes | (none) | 3 kHz | 3 | 10 minutes | Color bar | 1 kHz | 4 | 3 minutes | RF sweep | (none) | Segment | Playback Time | Video Signal | Audio Signal | 1 | 10 minutes | Stairstep | 6 kHz | 2 | 5 minutes | (none) | 3 kHz | 3 | 10 minutes | Color bar | 1 kHz 0 dB | 4 | 3 minutes | RF sweep | (none) |
| Segment | Playback Time | Video Signal | Audio Signal | | | | | | | | | | | | | | | | | | | | | | | | | | | | | | | | | | | | | | | | | |
| 1 | 10 minutes | Stairstep | 7 kHz | | | | | | | | | | | | | | | | | | | | | | | | | | | | | | | | | | | | | | | | | |
| 2 | 5 minutes | (none) | 3 kHz | | | | | | | | | | | | | | | | | | | | | | | | | | | | | | | | | | | | | | | | | |
| 3 | 10 minutes | Color bar | 1 kHz | | | | | | | | | | | | | | | | | | | | | | | | | | | | | | | | | | | | | | | | | |
| 4 | 3 minutes | RF sweep | (none) | | | | | | | | | | | | | | | | | | | | | | | | | | | | | | | | | | | | | | | | | |
| Segment | Playback Time | Video Signal | Audio Signal | | | | | | | | | | | | | | | | | | | | | | | | | | | | | | | | | | | | | | | | | |
| 1 | 10 minutes | Stairstep | 6 kHz | | | | | | | | | | | | | | | | | | | | | | | | | | | | | | | | | | | | | | | | | |
| 2 | 5 minutes | (none) | 3 kHz | | | | | | | | | | | | | | | | | | | | | | | | | | | | | | | | | | | | | | | | | |
| 3 | 10 minutes | Color bar | 1 kHz 0 dB | | | | | | | | | | | | | | | | | | | | | | | | | | | | | | | | | | | | | | | | | |
| 4 | 3 minutes | RF sweep | (none) | | | | | | | | | | | | | | | | | | | | | | | | | | | | | | | | | | | | | | | | | |
| 2 DC level adjustment (Picture effect adjustment) | Connect a DC voltmeter between rD10 anode (point c) and +5V (point d) of F-4706. See Bottom View on page 13. | rVR10 (F-4706) See Bottom View on page 13. | DC 1.6 ± 0 V | Power switch ON | | | | | | | | | | | | | | | | | | | | | | | | | | | | | | | | | | | | | | | | |
| 3 WHITE level adjustment (ART-1 brightness adjustment) | Connect a DC voltmeter between rVR11 (point e) and +5V (point d) of F-4706. See Bottom View on page 13. | rVR11 (F-4706) See Bottom View on page 13. | DC 750 ± 10 mV | Power switch ON | | | | | | | | | | | | | | | | | | | | | | | | | | | | | | | | | | | | | | | | |

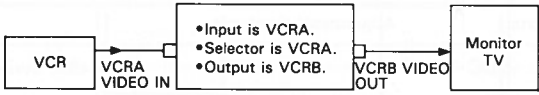
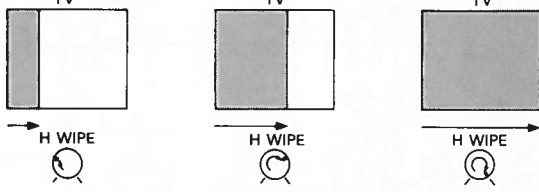
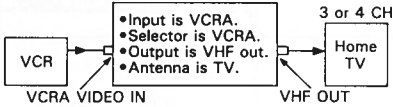
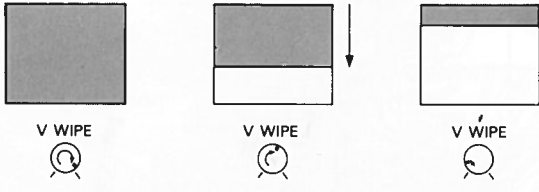
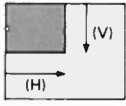
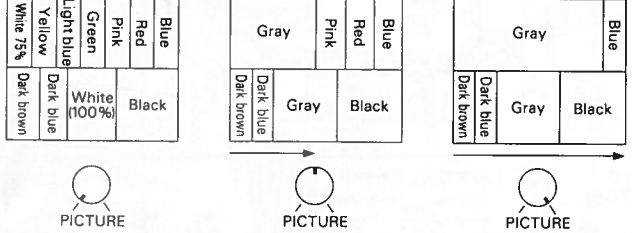
| Adjustment Procedure | Adjustment Contents | Adjusting Conditions | | | | | | | | | | | | | | |
|---|---|---|-----------|--------|------------|-------|------|-----|------|------------|-----------|--------------|-------|--|--|--|
| 4 V-WIPE, H-WIPE, PICTURE operation check | <p>Connect VCR and monitor TV as shown below:</p>  | <ol style="list-style-type: none"> 1.Connect VCR to VCR A VIDEO IN terminal. 2.Reproduce color bar signals of a test tape by VCR. (See Adjust condition of BFB Adjustment of Item 1.) 3.VIDEO ART switch Art 1 4.PICTURE control knob Full clockwise 5.FADER IN 6.If no monitor TV is prepared, use home TV with RF tuner as follows. | | | | | | | | | | | | | | |
| (1) H-WIPE operation check | <ol style="list-style-type: none"> 1.Rotate V-WIPE control knob full clockwise. 2.Check that a gray surface on TV picture increases gradually from left to right when the knob is rotated clockwise and that the TV picture is gray entirely when the knob is rotated full clockwise.  |  | | | | | | | | | | | | | | |
| (2) V-WIPE operation check | <ol style="list-style-type: none"> 1.Rotate H-WIPE control knob full clockwise. 2.Check that a gray surface decreases gradually from bottom to top when the knob is rotated counterclockwise and that the gray surface disappears when the knob is rotated full counterclockwise.  | | | | | | | | | | | | | | | |
| (3) H-and-V WIPE combined operation check | <p>Check that the gray surface is on a quarter of TV picture when the left half becomes gray by adjusting H-WIPE control and when the upper half becomes gray by adjusting V-WIPE control.</p>  | | | | | | | | | | | | | | | |
| (4) PICTURE and ART 1 operation check | <ol style="list-style-type: none"> 1.Rotate V-and-H WIPE control knobs full counterclockwise. 2.Set VIDEO ART to OFF. 3.Rotate PICTURE full counterclockwise. 4.Check hues of test pattern color mode. 5.Rotate V-and-H WIPE control knobs full clockwise. 6.Set VIDEO ART switch to ART-1. 7.Check that pattern hue changes to gray from white, sometimes yellow color of the left side TV picture and also the upper right end of TV picture changes from blue to gray when PICTURE is gradually rotated clockwise.  | <p>•Hues of test pattern color mode</p> <table border="1" data-bbox="1170 1157 1344 1304"> <tr> <td>White 75%</td> <td>Yellow</td> <td>Light blue</td> <td>Green</td> <td>Pink</td> <td>Red</td> <td>Blue</td> </tr> <tr> <td>Dark brown</td> <td>Dark blue</td> <td>White (100%)</td> <td colspan="3">Black</td> <td></td> </tr> </table> <p>Note: The hue of Test Pattern differs depend on Monitor TV.</p> | White 75% | Yellow | Light blue | Green | Pink | Red | Blue | Dark brown | Dark blue | White (100%) | Black | | | |
| White 75% | Yellow | Light blue | Green | Pink | Red | Blue | | | | | | | | | | |
| Dark brown | Dark blue | White (100%) | Black | | | | | | | | | | | | | |
| (5) PICTURE and ART 2 operation check | <ol style="list-style-type: none"> 1.Perform above procedure 1 to 5 under Item (4) PICTURE and ART 1 operation check. 2.Set VIDEO ART switch to ART-2. 3.Check that pattern hue changes from white, sometimes yellow color of the left side TV picture and also blue on the left end of TV picture changes to a hue different from the original hue when PICTURE is gradually rotated clockwise. | | | | | | | | | | | | | | | |
| (6) PICTURE and ART 3 operation check | <ol style="list-style-type: none"> 1.Perform above procedure 1 to 5 under Item (4) PICTURE and ART 1 operation check. 2.Set VIDEO ART switch to ART-3. 3.Check that pattern hue changes from white, sometimes yellow color of the left side TV picture and also blue on the left end of TV picture changes to a hue different from the original hue when PICTURE is gradually rotated clockwise. | | | | | | | | | | | | | | | |

5. PARTS LOCATION & PARTS LIST

5-1. F-4715 Power Supply Circuit Board (Stock No. 00825901) <XX, UL, EU, BS>/ (Stock No. 00825903) <CSA> Component Side

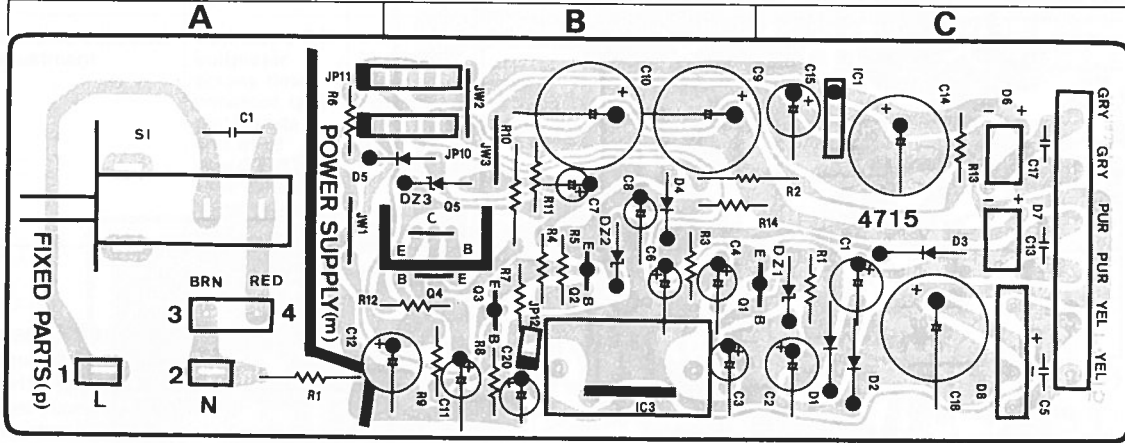

Parts List

| Parts No. | Stock No. | Description |
|--------------|-------------|-------------|
| • Transistor | | |
| △mQ1 | 48000801 | 2SA934 |
| △mQ2 | 46392001 | 2SA1175 |
| △mQ3 | 46392001 | 2SA1175 |
| △mQ4 | 46391901 | 2SC2785 |
| △mQ5 | 03083901 | 2SD313 |
| | or 46546701 | 2SD880 |
| • IC | | |
| △mIC1 | 46499800 | L78N09 |
| △mIC3 | 48116100 | SI-3122V |
| • Diode | | |
| △mD1 | 03117700 | 10E-2 |
| △mD2 | 03117700 | 10E-2 |
| △mD3 | 03117700 | 10E-2 |
| mD4 | 03117600 | 1S2473T77 |

| Parts No. | Stock No. | Description |
|---------------|-----------|----------------------------------|
| mD5 | 03117600 | 1S2473T77 |
| △mD6 | 46273600 | DBB10-B |
| △mD7 | 46273600 | DBB10-B |
| △mD8 | 03117000 | RB152-LFF |
| • Zener Diode | | |
| mDZ1 | 46103900 | 05Z13-X |
| mDZ2 | 46103100 | 05Z10-Y |
| mDZ3 | 46103900 | 05Z13-X |
| △mR13 | 00137100 | 82Ω 1/2W N.I.R. |
| △mR14 | 00135400 | 470Ω 1/2W N.I.R. |
| pC1 | 46425800 | 0.01μF 400V C.C. |
| pS1 | 46360300 | Push SW., POWER <XX, UL, EU, BS> |
| | 48065000 | Push SW., POWER <CSA> |

5-2. F-4710 Audio Terminal Circuit Board Component Side

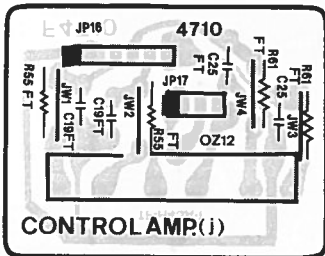

Parts List

| Stock No. | Description |
|-----------|------------------------|
| 48115400 | 6P Audio/TAPE Terminal |

5-3. F-4711 Antenna Switch Circuit Board Component Side

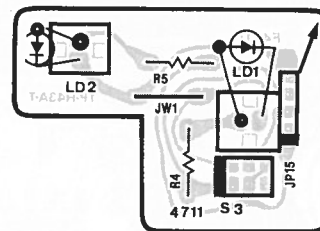

Parts List

| Parts No. | Stock No. | Description |
|-----------|-----------|-------------------|
| nLD1 | 48076200 | SEL2913K |
| nLD2 | 46169300 | SEL1210S |
| oS3 | 46463300 | Push SW., ANTENNA |

5-4. F-4713 Video Camera Socket Circuit Board Component Side

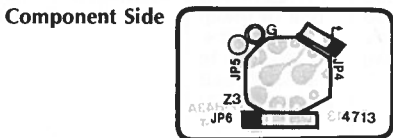

Parts List

| Parts No. | Stock No. | Description |
|-----------|-----------|---------------------|
| oS3 | 48114800 | Video Camera Socket |

5-5. F-4706 Video Effector Circuit Board (Stock No. 00824901)

Component Side

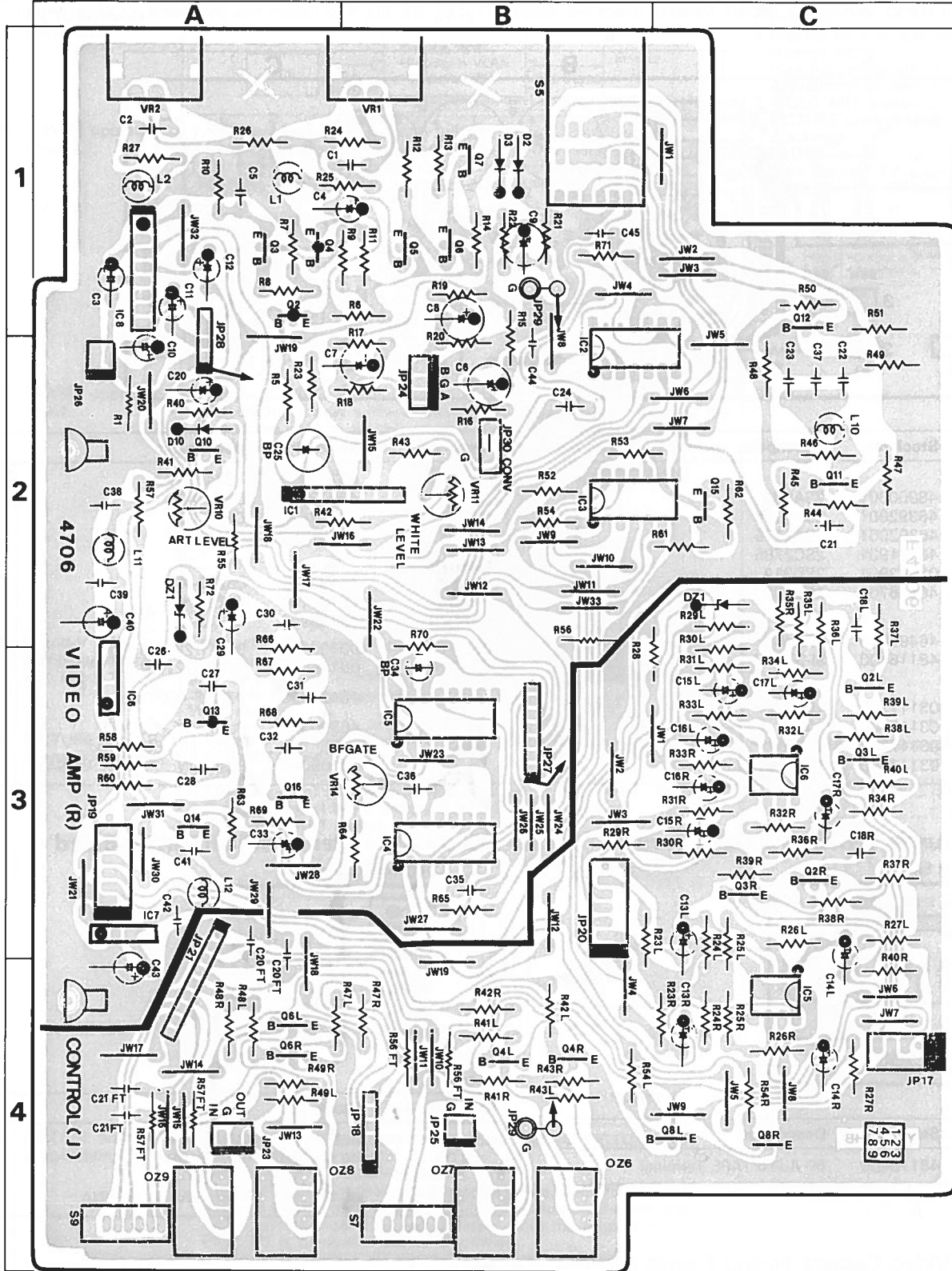

Parts List <F-4706>

| Parts No. | Stock No. | Description |
|---------------------|-------------|-----------------------|
| •Transistor | | |
| jQ2 | 46604301 | 2SC3327 |
| | or 48055901 | 2SD1468 |
| jQ3 | 46604301 | 2SC3327 |
| | or 48055901 | 2SD1468 |
| jQ4 | 46604301 | 2SC3327 |
| | or 48055901 | 2SD1468 |
| jQ6 | 46604301 | 2SC3327 |
| | or 48055901 | 2SD1468 |
| jQ8 | 46604301 | 2SC3327 |
| | or 48055901 | 2SD1468 |
| •IC | | |
| jIC5 | 07208900 | NJM4558D-X |
| | or 46580100 | M5218P |
| jIC6 | 07208900 | NJM4558D-X |
| | or 46580100 | M5218P |
| •Zener Diode | | |
| jDZ1 | 46111700 | 05Z6.2-X |
| jC18 | 46696400 | 0.33 μ F 50V F.C. |
| oS5 | 48114200 | Rotary SW., VIDEO ART |
| oS7 | 46177200 | Slide SW., MONO/ST |
| •Transistor | | |
| rQ2 | 46367001 | 2SA1115 |
| rQ3 | 46392401 | 2SC2668 |
| rQ4 | 46367001 | 2SA1115 |
| rQ5 | 46392401 | 2SC2668 |
| rQ6 | 03063001 | 2SC1360 |
| rQ7 | 46725801 | 2SC1627A |
| rQ10 | 46367101 | 2SC2603 |
| rQ11 | 46393201 | 2SC2786 |
| rQ12 | 46367101 | 2SC2603 |
| rQ13 | 46367001 | 2SA1115 |
| rQ14 | 46367101 | 2SC2603 |
| rQ15 | 46367101 | 2SC2603 |
| rQ16 | 46367101 | 2SC2603 |
| •IC | | |
| rIC1 | 48116000 | LA7016 |
| rIC2 | 48115900 | LM710 |

| Parts No. | Stock No. | Description |
|---------------------|-------------|---|
| rIC3 | 48115600 | HD74LS20P |
| | or 48115700 | MB74LS20 |
| | or 48115800 | M74LS20P |
| rIC4 | 46429800 | MB74LS123M |
| | or 46720800 | M74LS123P |
| | or 48114600 | HD74LS123P |
| rIC5 | 46429800 | MB74LS123M |
| | or 46720800 | M74LS123P |
| | or 48114600 | HD74LS123P |
| rIC6 | 46361500 | L78N12 |
| rIC7 | 46359400 | L78N05 |
| rIC8 | 48116000 | LA7016 |
| •Diode | | |
| rD2 | 03117600 | 1S2473T77 |
| rD3 | 03117600 | 1S2473T77 |
| rD10 | 03117600 | 1S2473T77 |
| •Zener Diode | | |
| rDZ1 | 46111700 | 05Z6.2-X |
| rC25 | 08450700 | 33 μ F 10V E.B. |
| rC26 | 46697600 | 0.1 μ F 50V F.C. |
| rC28 | 46692800 | 1000pF 50V F.C. |
| rC30 | 46692800 | 1000pF 50V F.C. |
| rC31 | 46695200 | 0.01 μ F 50V F.C. |
| rC32 | 46695200 | 0.01 μ F 50V F.C. |
| rC34 | 08451700 | 1 μ F 50V F.B. |
| rC35 | 46695200 | 0.01 μ F 50V F.C. |
| rC36 | 46692800 | 1000pF 50V F.C. |
| rL1 | 46204900 | Inductor 47 μ H |
| rL2 | 46204900 | Inductor 47 μ H |
| rL10 | 46204900 | Inductor 47 μ H |
| rL11 | 46204100 | Inductor 2.2 μ H |
| rL12 | 46204100 | Inductor 2.2 μ H |
| rVR1 | 48113500 | 10k Ω (B) V.R., SHARPNESS |
| rVR2 | 48113500 | 10k Ω (B) V.R., DETAIL |
| rVR10 | 46633700 | 1k Ω (B) S.V.R., DC Level |
| rVR11 | 46633700 | 1k Ω (B) S.V.R., Video Art Luminance |
| rVR14 | 46634300 | 10k Ω S.V.R., B.F.G Adjust |

5-6. F-4707 Video Effector Volume Circuit Board

Component Side

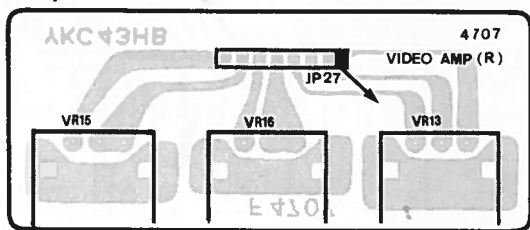

Parts List

| Parts No. | Stock No. | Description |
|-----------|-----------|---------------------------------|
| rVR13 | 48113800 | 1k Ω (B) V.R., PICTURE |
| rVR15 | 48113600 | 20k Ω (B) V.R., H. WIPE |
| rVR16 | 48113700 | 100k Ω (B) V.R., V. WIPE |

5-7. F-4708 Video Fader Circuit Board

Component Side

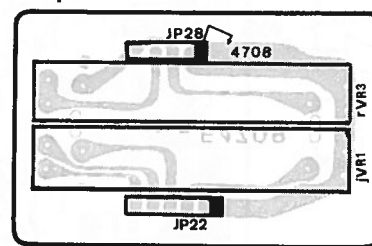

Parts List

| Parts No. | Stock No. | Description |
|-----------|-----------|-------------------------------------|
| jVR1 | 48113400 | 100k Ω (B) V.R., Audio FADER |
| rVR3 | 48145700 | 100k Ω (A) V.R., Video FADER |

5-8. F-4709 Noise Reduction Circuit Board (Stock No. 00825301 = NTSC System) <XX, UL, CSA>/ (Stock No. 00832601 = PAL System) <XX, EU>/ (Stock No. 00832606 = PAL System) <BS>
Component Side

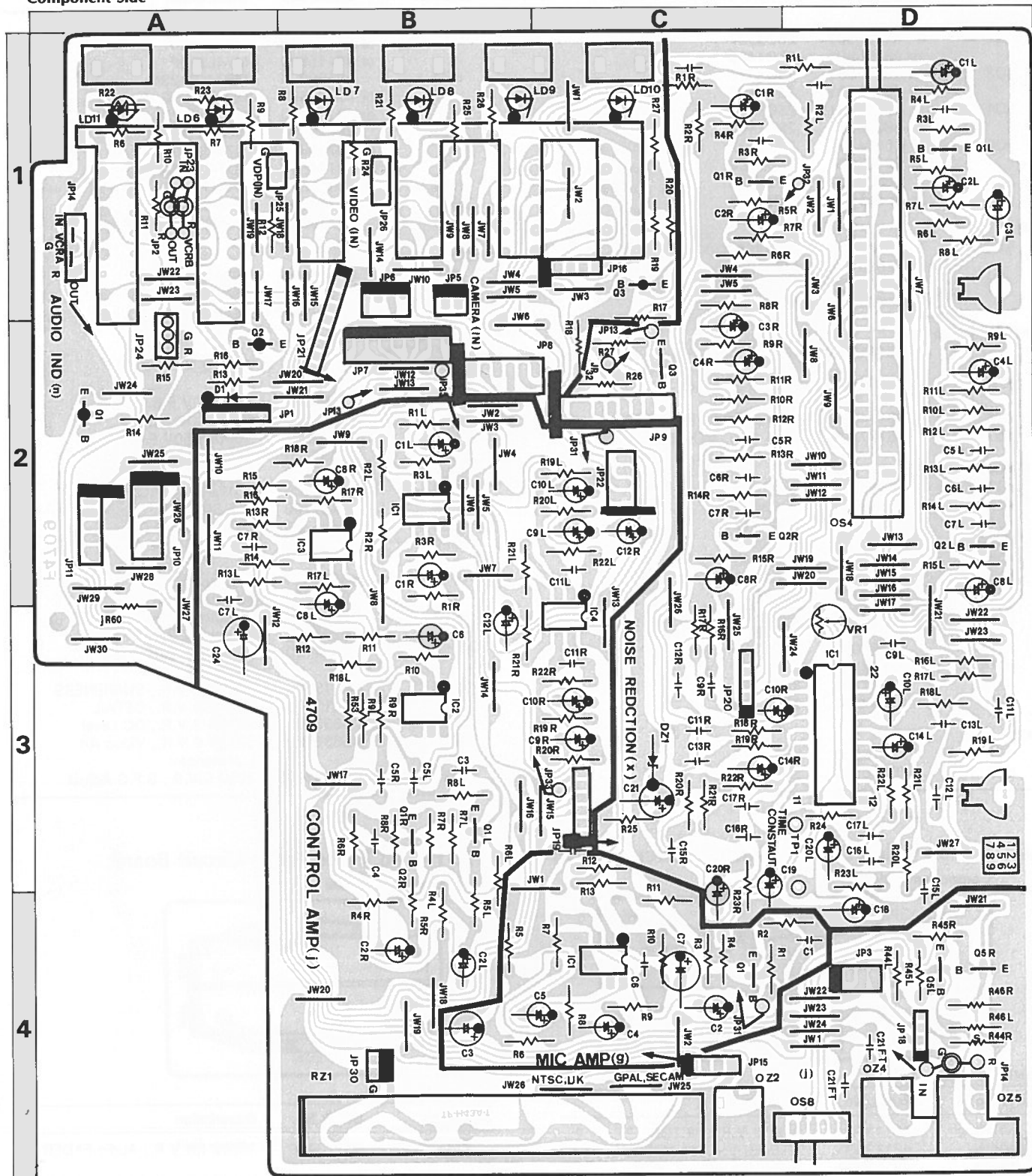

3. OPERATION

A. dbx System Operation

•Configuration and Principle

The dbx system accurately compresses signals to be recorded to half in logarithmic value before the signals are inputted to a recording system and expands the compressed signals to double when the signals are played back. For instance, in the case where a program source has a dynamic range of 100 dB, the source is compressed to 50 dB in recording, as shown in Fig. 3-1. Therefore, if the dynamic range of a cassette deck is 60 dB, it is possible to record the abovementioned program source perfectly. On the other hand, the recorded signals are returned to music signals having a dynamic range of 100 dB when played back. The system serves to reduce noise. That is, since the recording level is raised beyond hiss noise level generated in recording, it is possible to improve the noise level as much as about 30 dB or more throughout the total frequency bandwidth.

The system is configured as shown in Fig. 3-2.

•Each section operation

1) Pre-emphasis and De-emphasis circuits

The pre-emphasis operation is to raise high-frequency signals in order to reduce noise modulation effect (noise breathing) of high-frequency

signals in recording. On the other hand, the de-emphasis operation is to lower the raised high-frequency signals in order to return the frequency characteristics to the flat state in playing back, therefore the characteristics of de-emphasis being complementary to those of pre-emphasis.

2) VCA (voltage controlled amplifier or attenuator)

In this amplifier, the amplification degree changes linearly and logarithmically according to a dc control voltage applied externally. Therefore, it is possible to compressor expand an input signal dynamic range within a wide range in dependence upon the characteristics of the voltage controlled amplifier.

3) Waiting network

This network is provided at the front stage of a level sensor in order to prevent tape recording saturation. In the network, the gain of encoder VCA is reduced with respect to high-frequency input signals.

4) Root Mean Square Value (RMS) level sensor

This sensor detects the effective value of input signal and outputs a dc control voltage proportional to the detected level in order to control the gain of VCA according to the level of the input signal.

Fig. 3-1

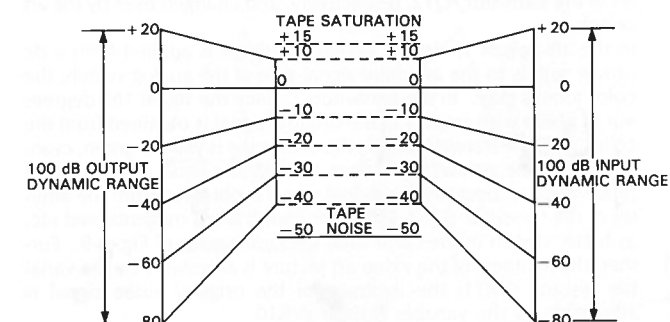
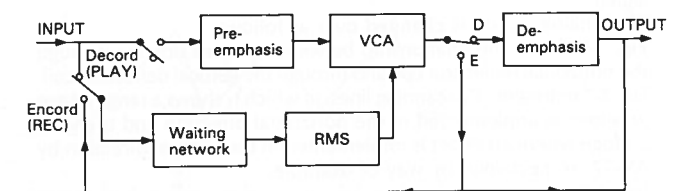

Fig. 3-2



"dbx" is a trademark of DBX Incorporated. DBX noise reduction system manufactured under license from DBX Incorporated.

B. Phase Response of Multi Dimension Circuit

Fig. 3-3

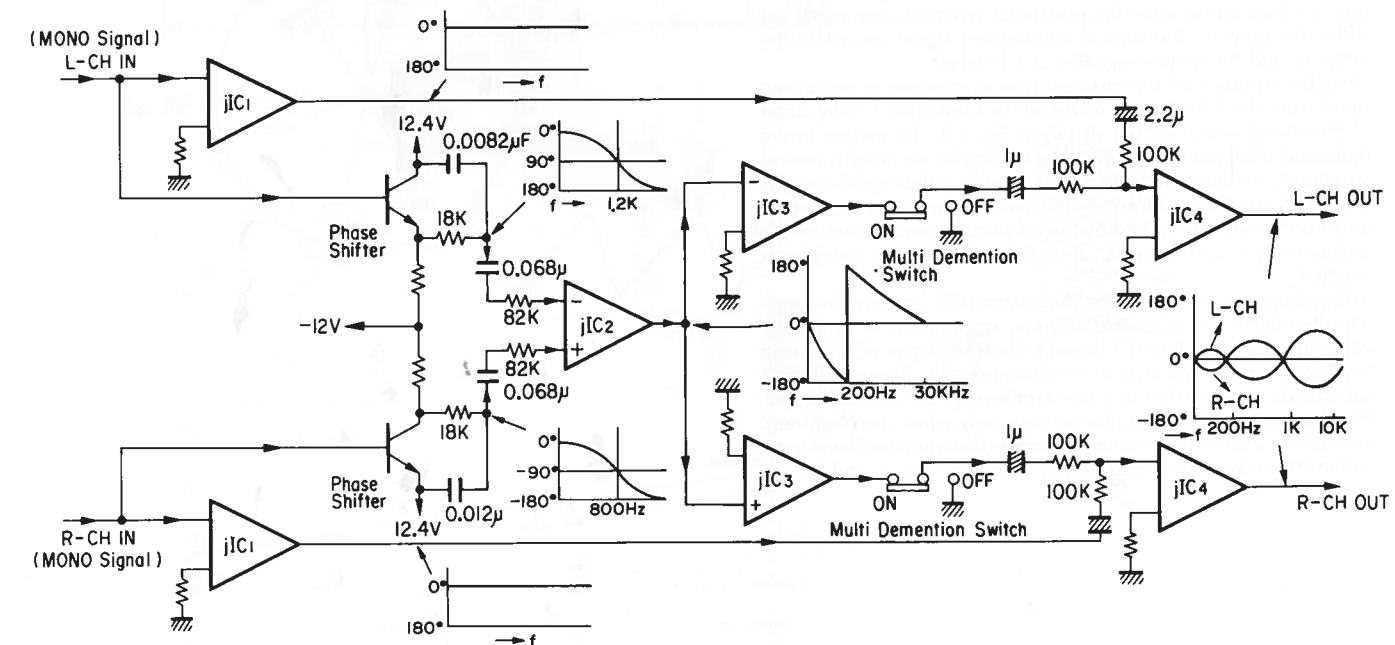

•When used on stereo programs, speeds sound even more than normal with mono programs, create a lated stereo effect.

Parts List <F-4709>

| Parts No. | Stock No. | Description |
|-------------------------------------|--|--|
| •Transistor gQ1 | 46604301 or 48055901 | 2SC3327 2SD1468 |
| •Transistor jQ1 jQ5 | 46367101 46604301 or 48055901 | 2SC2603 2SC3327 2SD1468S |
| •IC gIC1 | 07208900 or 46580100 | NJM4558D-X M5218P |
| •IC jIC1 jIC2 jIC3 jIC4 | 07208900 or 46580100 07208900 or 46580100 07208900 or 46580100 07208900 or 46580100 | NJM4558D-X M5218P NJM4558D-X M5218P NJM4558D-X M5218P NJM4558D-X M5218P |
| jC3 jC4 jC5 jC7 | 46695000 46695400 46697200 46697200 | 8200pF 50V F.C. 0.012μF 50V F.C. 0.068μF 50V F.C. 0.068μF 50V F.C. |
| Δ jR60 | 00133200 | 22Ω 1/2W N.I.R. |
| •Transistor nQ1 nQ2 nQ3 | 46367001 46367001 46367001 | 2SA1115 2SA1115 2SA1115 |
| •Diode nD1 | 03117600 | 1S2473T77 |
| •LED nLD6 | 48111700 | SEL2413E |

| Parts No. | Stock No. | Description |
|---|--|---|
| nLD7 nLD8 nLD9 nLD10 nLD11 | 48111700 48111700 48111700 48111700 48111700 | SEL2413E SEL2413E SEL2413E SEL2413E SEL2413E |
| oS1 oS4 oS8 | 48114100 48114300 46177200 | Push SW., SELECTOR Slide Rotary Switch, dbx Slide SW., MONO/ST |
| oZ2 | 46411800 | Mini Jack, CAMERA REMOTE |
| rZ1 | 48114900 | MCB1-VU, RF Converter Unit <<NTSC>> <XX, UL, CSA> |
| | 48115300 | MCB1-UG, RF Converter Unit <<PAL>> <BS> |
| | 48115200 | MCB1-VG3601 RF Converter Unit <<PAL>> <XX, EU> |
| •Transistor xQ1 xQ2 xQ3 | 46367101 46367101 46367101 | 2SC2603 2SC2603 2SC2603 |
| •IC xIC1 | 48111900 | AN6291 |
| •Zener Diode xDZ1 | 46111200 | 05Z5.1-Y |
| xC5 xC6 xC9 xC12 xC13 xC15 xC17 | 46694000 46694000 46696400 46696000 46286400 46694400 46696000 | 3300pF 50V F.C. 3300pF 50V F.C. 0.33μF 50V F.C. 0.22μF 50V F.C. 0.68μF 63V F.C. 4700pF 50V F.C. 0.22μF 50V F.C. |
| xVR1 | 46633900 | 2.2kΩ S.V.R., Time Constant |

5-9. F-4712 MIC Mixing Level Volume Circuit Board

Component Side

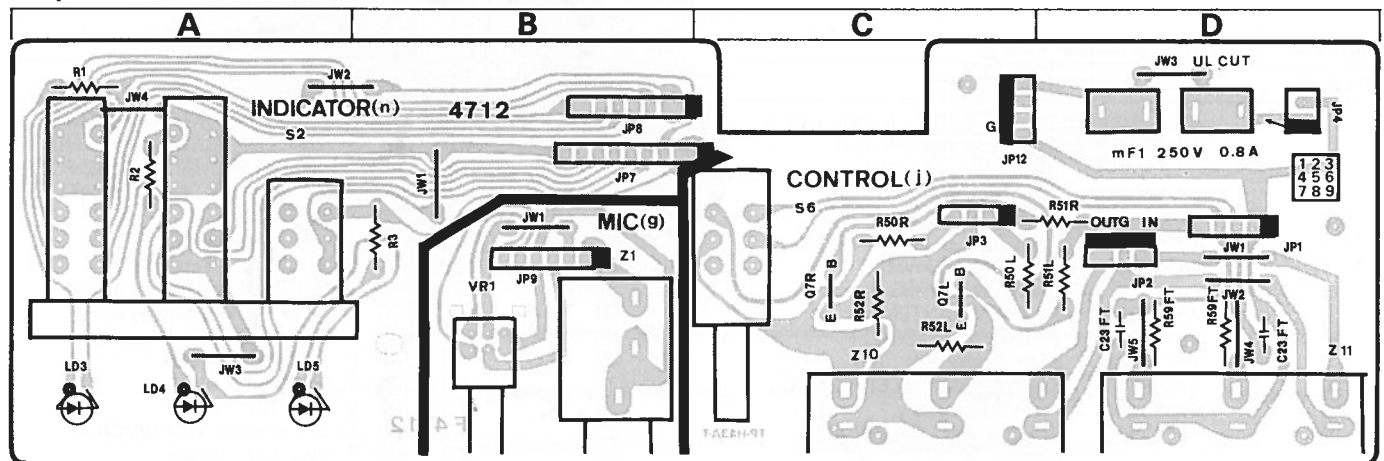

Parts List

| Parts No. | Stock No. | Description |
|------------------------------|----------------------------------|----------------------------------|
| gVR1 | 48113900 | 50kΩ (B) V.R., MIC MIXING |
| •Transistor jQ7 | 48055901 or 46604301 | 2SD1468S 2SC3327 |
| •LED nLD3 nLD4 nLD5 | 48111500 48111500 48111500 | SEL2210S SEL2210S SEL2210S |

| Parts No. | Stock No. | Description |
|-----------|----------------------|--|
| oS2 | 48114500 | Push SW., AUDIO INSERT/MULTI DEMENTION |
| oS6 | 46164900 | Push SW., MONO/ST |
| oZ1 | 46085000 46201400 | Mic Jack 800mA Fuse |

6. OTHER PARTS

6-1. Front View

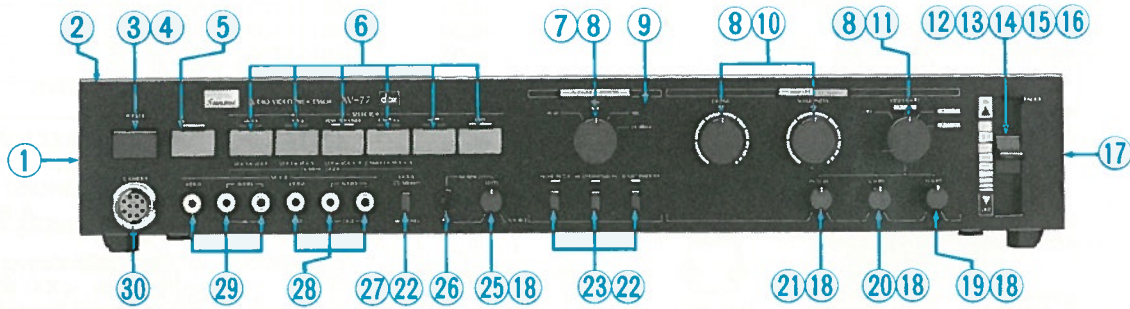

6-2. Bottom View

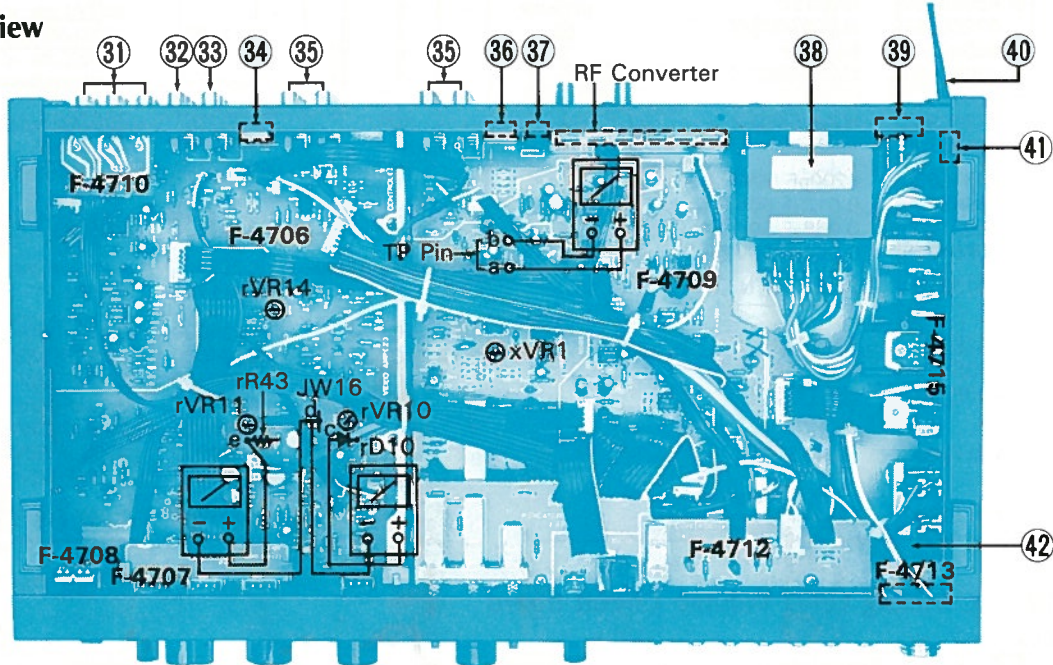

Parts List <Front View & Bottom View>

| Parts No. | Stock No. | Description | Parts No. | Stock No. | Description |
|-----------|-----------|---|-----------|-----------|---|
| 1 | 47684900 | Side Panel Ass'y (L-CH) | 22 | 47658900 | Knob, MODE/NOISE FILTER/etc. |
| | 47315610 | Side Panel Ass'y (L-CH) <XX, CSA, EU, BS> | 23 | 48114500 | Push SW., AUDIO INSERTER/MULTI DIMENSION/NOISE FILTER |
| 2 | 47256200 | Metal Bonnet | 25 | 48113900 | 50kΩ (B) V.R., MIC MIXING |
| 3 | 47633700 | Knob, POWER SW. | 26 | 46085000 | Mic Jack |
| △ 4 | 48065000 | Push SW., POWER <CSA> | 27 | 46164900 | Push SW., MODE |
| △ 4 | 46360300 | Push SW., POWER <XX, UL, EU, BS> | 28 | 48115500 | 3P OUTPUT Terminal |
| 5 | 46463300 | Push SW., ANTENNA | 29 | 48115500 | 3P INPUT Terminal |
| 6 | 48114100 | Push SW., SELECTOR | 30 | 48114800 | Video Camera Socket |
| 7 | 48114300 | Slide Rotary SW., dbx | 31 | 48115400 | 6P AUDIO/TAPE Terminal |
| 8 | 47658500 | Knob, dbx/VIDEO EFFECTOR | 32 | 48114700 | 3P TAPE Terminal |
| 9 | 47659200 | Front Panel Ass'y | 33 | 48114700 | 3P VDP Terminal |
| 10 | 48113500 | 10kΩ(B) V.R., SHARPNESS/DETAIL | 34 | 46177200 | Slide SW., MODE |
| 11 | 48114200 | Rotary SW., VIDEO ART | 35 | 48114700 | 3P Terminal, VCR B/VCR A |
| 12 | 48113400 | 100kΩ (B) V.R., AUDIO FADER | 36 | 46177200 | Slide SW., MODE |
| 13 | 48145700 | 100kΩ (A) V.R., VIDEO FADER | 37 | 46411800 | Mini Jack, CAMERA REMOTE |
| 14 | 47110000 | FADER Volume Knob | △ 38 | 15018401 | Power Transformer <XX> |
| 15 | 47111100 | FADER Volume Mask | △ | 15018402 | Power Transformer <UL, CSA> |
| 16 | 47110910 | Slide Volume Holder | △ | 15018505 | Power Transformer <EU, BS> |
| 17 | 47685000 | Side Panel Ass'y (R-CH) | △ 39 | 48069600 | Voltage Selector SW. <XX> |
| | 47314820 | Side Panel Ass'y (R-CH) <XX, CSA, EU, BS> | △ | 48111800 | Voltage Selector SW., <EU, BS> |
| 18 | 47636100 | Knob, PICTURE/H. WIPE/V. WIPE/MIC | △ 40 | 46604400 | Power Supply Cord <XX, UL, CSA> |
| 19 | 48113600 | 20kΩ (B) V.R., H. WIPE | △ | 38004500 | Power Supply Cord <EU> |
| 20 | 48113700 | 100kΩ (B) V.R., V. WIPE | △ | 38004300 | Power Supply Cord <BS> |
| 21 | 48113800 | 1kΩ (B) V.R., PICTURE | 41 | 47157300 | AC Cord Cover |
| | | | 42 | 47637300 | Joint Bar |

7. SCHEMATIC DIAGRAM

* Design and specifications subject to change without notice for improvement.
 * La présentation et les spécifications sont susceptibles d'être modifiées sans préavis par suites d'améliorations éventuelles.
 * Änderungen, die dem technischen Fortschritt dienen, bleiben vorbehalten.

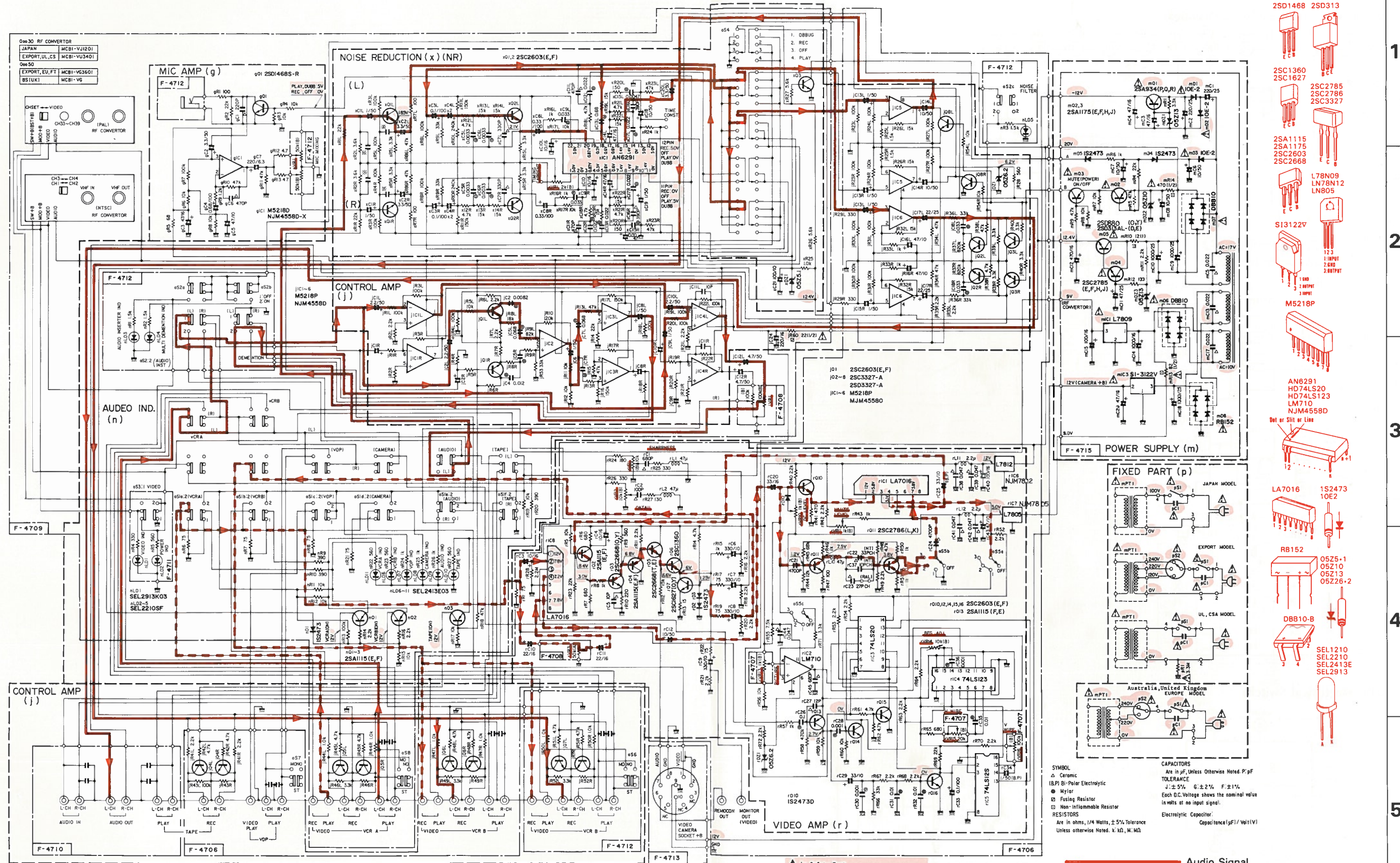

- 25D1468 25D313
- 25C1360 25C1627
- 25C2785 25C2786 25C3327
- 25A1115 25A1175 25C2603 25C2668
- L78N09 LN78N12 LN805
- S13122V
- M5218P
- AN6291 HD74LS20 HD74LS123 LM710 NJM4558D
- LA7016 1S2473 10E2
- RB152
- 05Z5-1 05Z10 05Z13 05Z26-2
- DB810-B
- SEL1210 SEL2210 SEL2413E SEL2913

SYMBOL
 Δ Ceramic
 (B/P) Bi-Polar Electrolytic
 ● Mylar
 ⊕ Fusing Resistor
 ⊖ Non-Inflammable Resistor
 RESISTORS
 Are in ohms, 1/4 Watts, ±5% Tolerance Unless otherwise Noted. k, M, M, MΩ

CAPACITORS
 Are in μF, Unless Otherwise Noted. P: pF
 TOLERANCE
 J: ±5% G: ±2% F: ±1%
 Each D.C. Voltage shows the nominal value in volts at no input signal.
 Electrolytic Capacitor: Capacitance(μF) / Volt(V)

▲ is Safety Part.
 Use only replacement parts recommended by the manufacturer.

— Audio Signal
 - - - Video Signal

1
2
3
4
5

8. INTERIOR BLOCK DIAGRAM OF IC

•AN6291 (Dual dbx Encoder & Decoder)

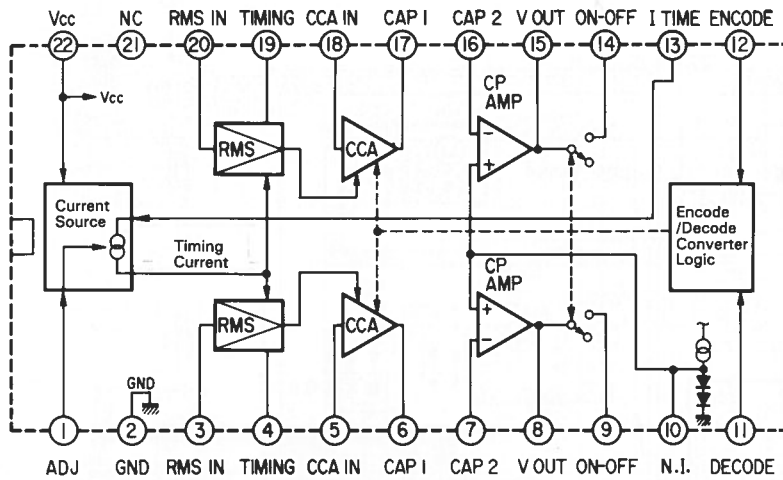

•Encode/Decode Converter Logic Condition

| 11 Pin | 12 Pin | Motion mode |
|--------|--------|-------------|
| Vcc | Open | Decode |
| Open | Vcc | Encode |
| Vcc | Vcc | Bypass |

•MB74LS123 (Multivibrator)

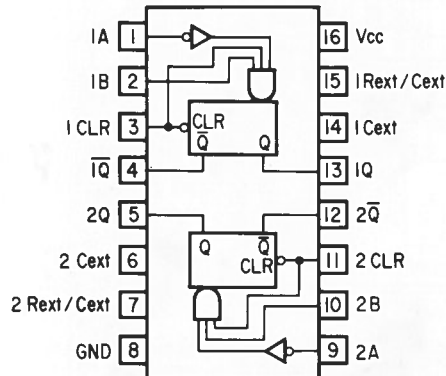

•Function Table <M74LS-123>

| CLEAR | INPUT | | OUTPUT | |
|-------|-------|---|---------|-----------|
| | A | B | Q | \bar{Q} |
| L | X | X | L | H |
| X | H | X | L | X |
| X | X | L | L | H |
| H | L | ↑ | [Pulse] | [Pulse] |
| H | ↓ | H | [Pulse] | [Pulse] |
| ↑ | L | H | [Pulse] | [Pulse] |

•M5218L/NJM4558D (Dual Operation Amp)

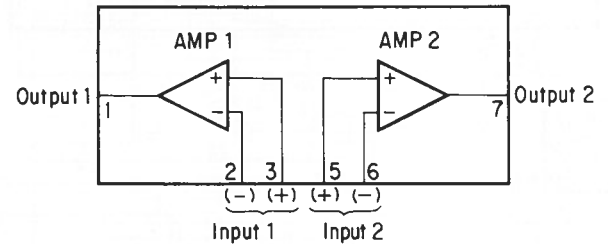

•HD74LS20P (Dual 4-Input-Positive Nand Gate)

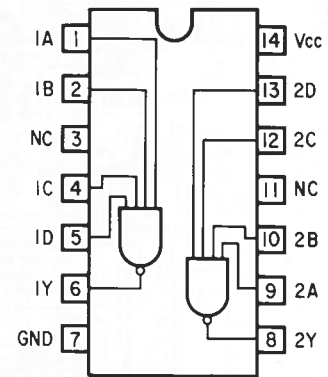

•LA7016 (Electrical Switch)

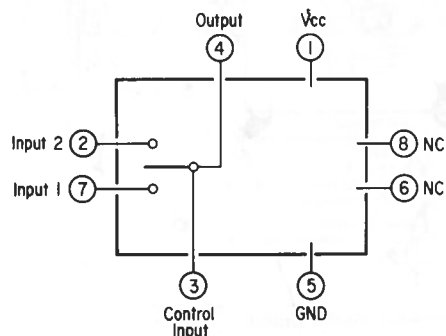

•Operative Condition
 Pin③ < 2.2V.....Pin⑦ → ④
 Pin③ > 3.0V.....Pin② → ④

•LM710 (Voltage Comparator)

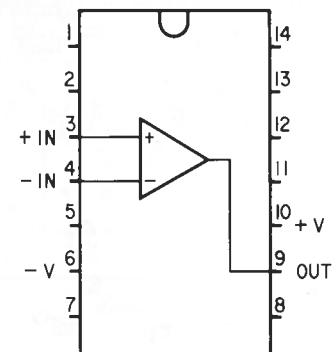

9. PACKING LIST

| Parts No. | Stock No. | Description |
|-----------|-----------|---------------------------|
| 1 | 07599500 | Vinyl Cover |
| 2 | 07827220 | Styrofoam Packing |
| 3 | 47716100 | Carton Case <EU> |
| | 47716200 | Carton Case <BS> |
| | 47658200 | Carton Case <XX, UL, CSA> |

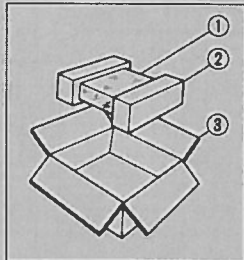

10. ACCESSORY LIST

| Stock No. | Description |
|-----------|--------------------------------|
| 46958800 | Operating Instruction <<PAL>> |
| 46958700 | Operating Instruction <<NTSC>> |
| 46267300 | 2P Mini Plug Cord |
| 38103300 | PJP Pin Plug Cord |
| 48111100 | Antenna Cord <<NTSC>> |
| 48111200 | Antenna Cord <<PAL>> |

SANSUI ELECTRIC CO., LTD.:

SANSUI ELECTRONICS CORPORATION:

SANSUI ELECTRONICS (U.K.) LTD.:
SANSUI ELECTRONICS G.M.B.H.:14-1, Izumi 2-chome, Suginami-ku, Tokyo 168 Japan
PHONE: (03) 324-8891/TELEX: 232-2076 (International Division)
1250 Valley Brook Ave. Lyndhurst, N.J. 07071 U.S.A.
17150 South Margay Ave. Carson, California 90746 U.S.A.
3036 Koapaka Street. Honolulu, Hawaii 96819 U.S.A.Unit 10A, Lyon Industrial Estate, Rockware Avenue, Geenford, Middx UB6, OAA, England
Pau Ehrich Strasse 8, 6074 Rödermark 2, West Germany