

SERVICE MANUAL

AUDIO MIXER

SANSUI AX-7

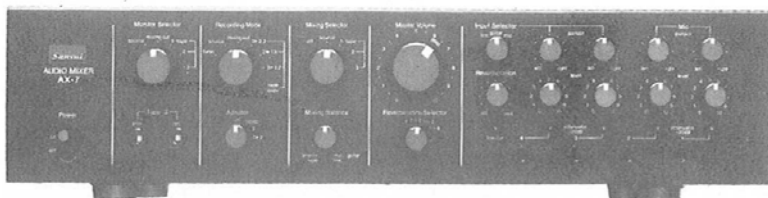

SPECIFICATIONS

Output voltage (at 1 kHz, less than 0.1% total harmonic distortion)

OUTPUT 1V
(Max. output voltage 5V)

TAPE REC 1V

Total harmonic distortion (20 to 20,000Hz, for rated output voltage) less than 0.1%

Frequency response

SOURCE IN, TAPE PLAY

. 20 to 20,000Hz +0dB -0.5dB

MIC, GUITAR, LINE. 20 to 20,000Hz +0dB -1.0dB

Input sensitivity and impedance (1 kHz)

MIC 1 mV/47 kilohms

(Max. input capability, 40 mV at 1 kHz, less than 0.1% total harmonic distortion)

GUITAR 20 mV/47 kilohms

LINE, SOURCE IN, TAPE PLAY

. 150 mV/47 kilohms

Hum and noise

MIC 57dB

GUITAR 55dB

LINE 66dB

SOURCE IN 72dB

Filter

LOW CUT -3dB (200Hz), 6dB/oct.

Power requirements

Power voltage 100, 120, 220, 240V
(50/60Hz)

For U.S.A. & Canada

. 120V (60Hz)

Power consumption 3 watts

Dimensions 482mm (19") W

110mm (4-3/8") H

299mm (11-13/16") D

Weight 5.3 kg (11.7 lbs) net

6.3 kg (13.9 lbs) packed

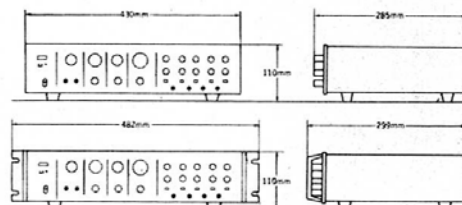

* Design and specifications subject to changes without notice for improvements.

* In order to simplify the explanation illustrations may sometimes differ from the originals.

Sansui

SANSUI ELECTRIC CO., LTD.

1. BLOCK DIAGRAM

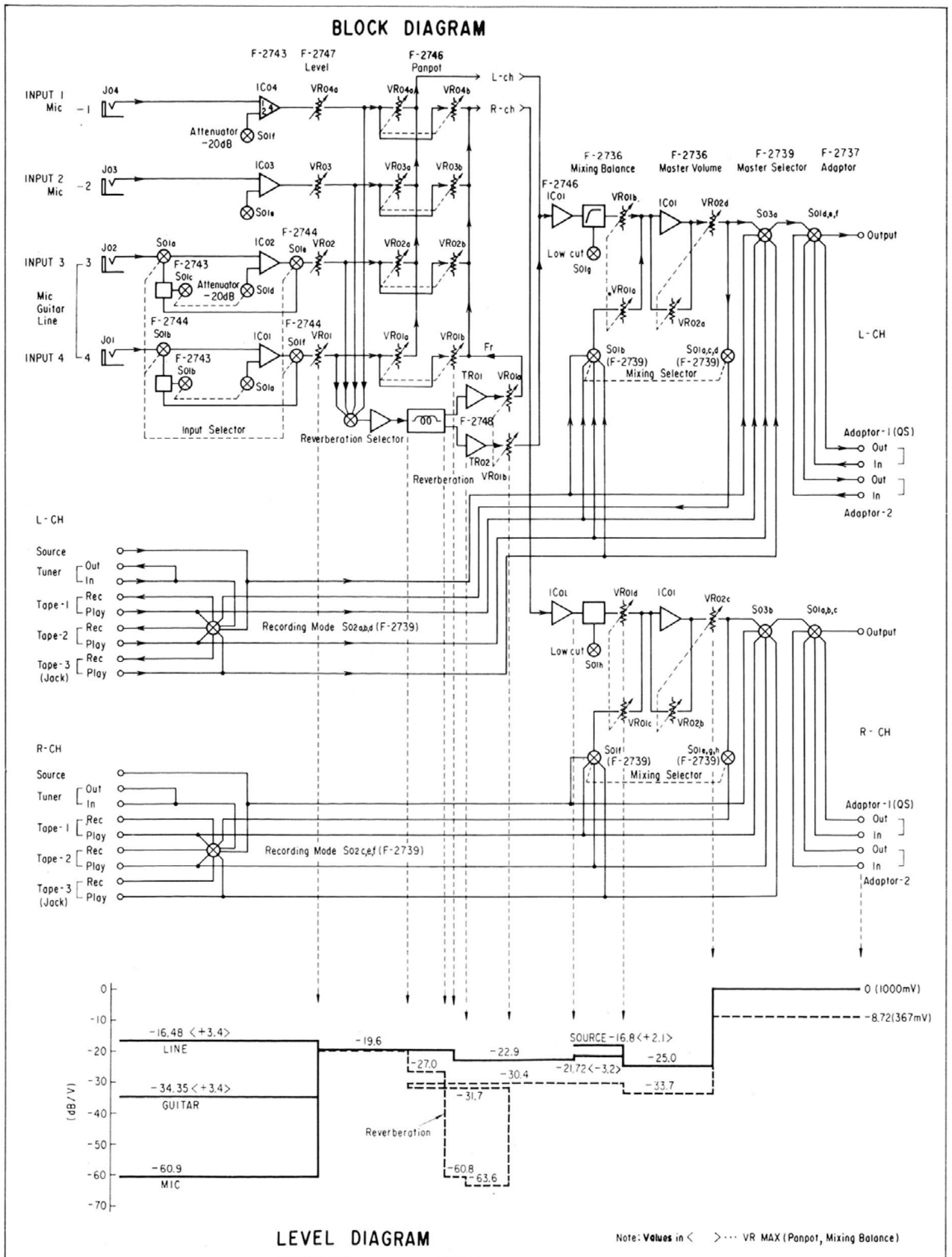

2. OPERATION OF EACH SELECTOR

The list shown below indicates the relation between input and output when turning over the selector switches. In the list, the mark ⊖ shows outputs passing through Master volume and the Mark ○ signifies outputs by-passing Master volume and comes directly from input terminal to output terminal.

For Instance:

When input signal comes from tuner at recording mode, a signal by-passing Master volume is appears at output terminal of Tape 1 Rec (Printed ● in the list below) only when the selector position is Recording Mode 1, in addition, output signal appears in any Mixing Selector position.

1) Recording mode switch

Input Terminal	Mixing Selector	Recording Mode Position																													
		1. Tuner						2. Source						3. Mixing out						4. Tape 1→2, 3											
		1	2	3	4	5	6	1	2	3	4	5	6	1	2	3	4	5	6	1	2	3	4	5	6						
Mic Guitar Line	off	⊖	⊖	⊖	⊖	⊖	⊖																								
	Source	⊖	⊖	⊖	⊖	⊖	⊖																								
	Tape 1	⊖	⊖	⊖	⊖	⊖	⊖																								
	Tape 2	⊖	⊖	⊖	⊖	⊖	⊖																								
	Tape 3	⊖	⊖	⊖	⊖	⊖	⊖																								
Tuner	off							○						○						○						○					
	Source							○						○						○						○					
	Tape 1							●						○						○						○					
	Tape 2							○						○						○						○					
	Tape 3							○						○						○						○					
Source	off							○						○						○						○					
	Source	⊖	⊖	⊖	⊖	⊖	⊖	○	⊖					○	⊖					○	⊖					○	⊖				
	Tape 1							○						○						○						○					
	Tape 2							○						○						○						○					
	Tape 3							○						○						○						○					
Tape 1 play	off																														
	Source																														
	Tape 1	⊖	⊖	⊖	⊖	⊖	⊖																								
	Tape 2																														
	Tape 3																														
Tape 2 play	off												○																		○
	Source												○																		○
	Tape 1												○																		○
	Tape 2	⊖	⊖	⊖	⊖	⊖	⊖						○																		○
	Tape 3												○																		○
Tape 3 play	off												○																		○
	Source												○																		○
	Tape 1												○																		○
	Tape 2												○																		○
	Tape 3	⊖	⊖	⊖	⊖	⊖	⊖						○																		○
						Out						Tape 1 Rec						Tape 2 Rec						Tape 3 Rec							
Output Terminal																															

2) Reverberation selector switch

Input Terminal	Reverberation Selector			
	1	1, 2	1~3	1~4
Mic 1	○	○	○	○
Mic 2		○	○	○
Mic 3			○	○
Mic 4				○
Right (Left) Out				

3) Monitor selector switch

Input Terminal	Monitor Selector Position				
	Source	Mixing Out	Tape 1	Tape 2	Tape 3
Mic Guitar Line		⊖			
Source	○	⊖			
Tape 1			○		
Tape 2				○	
Tape 3					○
Output					

4) Adaptor switch

Input Terminal	Adaptor	Output Terminal		
		Adaptor 1	Adaptor 2	Out
Source	off			⊖
	1 (QS)	⊖		
	2		⊖	
	1→2	⊖		
Adaptor 1	off			
	1 (QS)			○
	2			
	1→2		○	
Adaptor 2	off			
	1 (QS)			
	2			○
	1→2			○

3. FUNCTIONS

1) Input circuit

The input circuit is provided with the input jacks 1, 2, 3, and 4 on the front panel. The inputs, 1 and 2 are connected to the input circuit directly as shown in Block Diagram on page 1 (input sensitivity 1 mV/47 kΩ) designed to be used for Microphones, and the inputs, 3 and 4 are used for Microphone, Guitar and Line inputs (input sensitivity 1 mV, 20 mV, 150 mV/47 kΩ respectively), which can be switched over in accordance with the purpose of use. Therefore, this model, AX-7, can be operated always in the proper condition by changing over the input sensitivity to meet each application.

2) Input attenuator

This attenuator of -20 dB is equipped on the first stage of input circuit shown in the Block Diagram, thereby the input signal is attenuated -20 dB before the first stage of amplifier, which prevent an excessive clipped input signal into the amplifier directly. Consequently, the dynamic range of the amplifier can be utilized to the full.

The attenuator works at each position of the input sensitivity changeover of the input 3 and 4, therefore, this set, AX-7, can be applied to further various input levels by the combination of switching ON the attenuator and the input sensitivity changeover (= of switching OFF the attenuator).

	INPUT SENSITIVITY	
	RATING	-20dB ATT IN
MIC	1mV	10mV
GUITAR	20mV	200mV
LINE	150mV	1500mV

3) Input level adjustment

Each level of the inputs 1, 2, 3 and 4 can be individually adjusted by the level volume control provided for left & right channels, which permits the use of Microphones with different sensitivities and also the individual level variation of Guitar, Line inputs, 3 and 4. In other words, the input levels can be adjusted in the best balance because input signal level of each channel, 1, 2, 3 & 4 can be controlled by the independently equipped volume control.

4) Panpot function

This audio mixer, AX-7, has Panpot function which localizes, as you desire, the sound image of monophonic sound by signal given to input 1, 2, 3 or 4 between speakers L and R. Namely, this function allows to move the sound image as monaural sound continuously from one position to another between speakers, L and R during stereo reproduction. Therefore, the sound of each input signal into inputs, 1, 2, 3 & 4 can be moved desired sound-image localization between speakers, left and right by use of these function volumes, monitoring the reproduced stereo sound by signals given to L and R input terminals.

5) Reverberation function

A reverberation unit applying spring elasticity to this function is built in this AX-7, and the reverberation time can be varied as required within the range from 1.9 to 3.2 seconds. A reverberation unit produces echo sound of one or more combined as 1, 1 and 2, 1 to 3 and 1 to 4, against the signals provided into inputs, 1, 2, 3 and 4 on the front panel.

6) Low cut filter

When the frequency response extends too far into low-frequency band at public address, the separation of individual sound becomes worse. Even though low band is cut by this filter, sound quality is not harmed.

7) Master volume control

The levels of signals from individual inputs, 1, 2, 3 & 4 adjusted by level volume and mixed by mixing selector are totally controlled by Master volume control. As the levels are adjusted under condition that the sound images are localized between speakers, left and right by means of the panpot function, the position of sound image between two speakers does not change, even though the sound levels are varied by master volume control.

Also, this volume control works only at mixing-out position of monitor selector, and markings are provided between the positions, 6 to 6.5 of this control to get same sound level comparing to that from the source input terminal.

8) Recording mode

Three tape inputs, Tape-1, -2, -3 are provided, which permit simultaneous recording with three tape decks and tape dubbing from one deck to other. Irrelevant to the mixing-out position, recording of program sources such as FM broadcasting and discs, or tape dubbing from one to two decks can be performed. At the mixing-out position, the output signal controlled by the master volume is directly delivered to the REC terminals via recording mode switch.

9) Adaptors

Other adaptors (e.g. QS synthesizer, meter or equalizer amplifier etc.) can be connected in series between integrated stereo amplifier and this AX-7. Two adaptors can be connected in series at the position, 1 → 2 of adaptor switch.

10) Mixing Selector

This is a selection switch for mixing the signals of inputs, 1, 2, 3 and 4 with signal of the source from one of tape inputs, Tape-1, -2 or -3.

When mixing play is not needed and only input signals from input 1, 2, 3 & 4 are to be outputted, the off-position of this mixing selector is used.

11) Mixing Balance

This control has the function to get the same levels between signal selected by the mixing selector and input signals from Inputs, 1, 2, 3 & 4 on the front panel.

By turning this balance volume clockwise or counterclockwise fully, either signal from source inputs, tuner, tape-1 to tape-3 or one from input-1, -2, -3 & -4 (mic, guitar, line) remains.

12) Monitor Selector

This has the function to select output signal against input signals. At the source position, the signal from source input is directly given to OUTPUT terminals on rear panel. At the mixing-out position, the output signal balanced by the mixing balance control is delivered to the OUTPUT terminals. At this position, the master volume control functions, therefore, the total sound levels are controlled by the master volume control. And at the positions of Tape-1, Tape-2 & Tape-3, the output signal of each tape deck is directly sent to OUTPUT terminals.

4. PARTS LOCATION & PARTS LIST

1) F-2743 MIC AMP Circuit Board (Stock No. 7610171)

Conductor Side

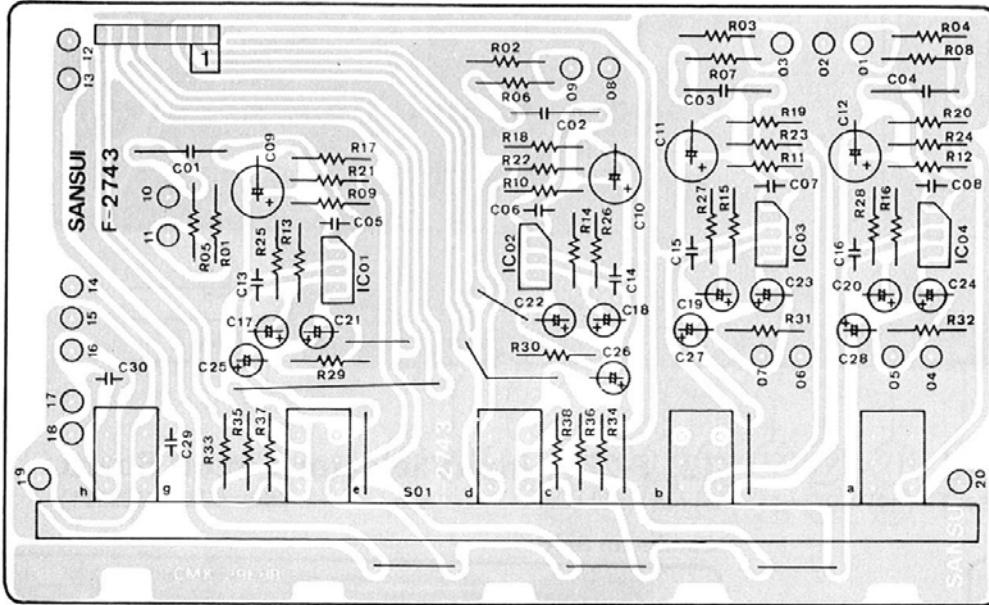

Parts List

Parts No.	Stock No.	Description
IC01 ~ 04	0360550	ML120 IC
C01 ~ 04	0602338	0.33 μ F 100V M.C.
S01	1131480	Low Cut Switch

2) F-2748 Reverberation Circuit Board (Stock No. 7595551)

Conductor Side

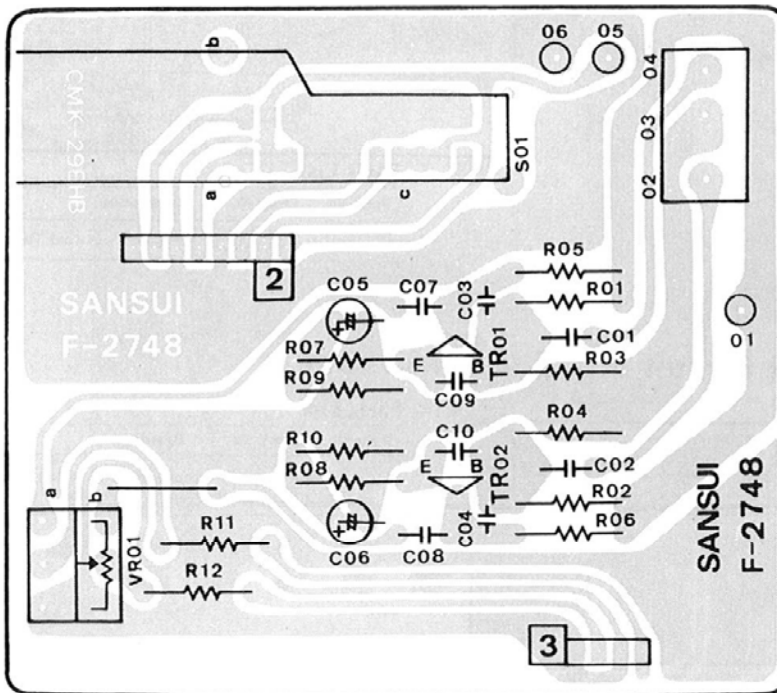

Parts List

Parts No.	Stock No.	Description
TR01, 02	0306010, 1	2SC1222(2) U, E
VR01	1015290, 1	50 k Ω B x 2
S01	1190450	Reverberation Selector Switch
	2410920	Type E 3P Pin Ass'y

3) F-2745 MIC Jack Circuit Board (Stock No. 7595541)

Conductor Side

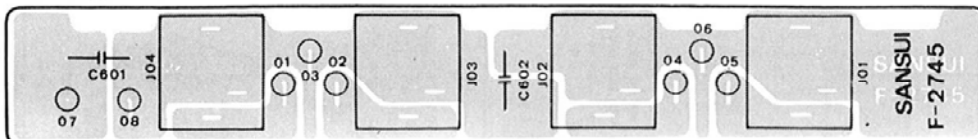

Parts List

Parts No.	Stock No.	Description
J01 ~ 04	2430310	S-G7637 Jack

Since some of capacitors and resistors are omitted from parts lists in this Service Manual, refer to the common parts list for capacitors & resistors which was appended previously to each Sansui Manual.

4) F-2746 Panpot Circuit Board (Stock No. 7562001)

5) F-2747 Level Volume Circuit Board (Stock No. 7562011)

Conductor Side

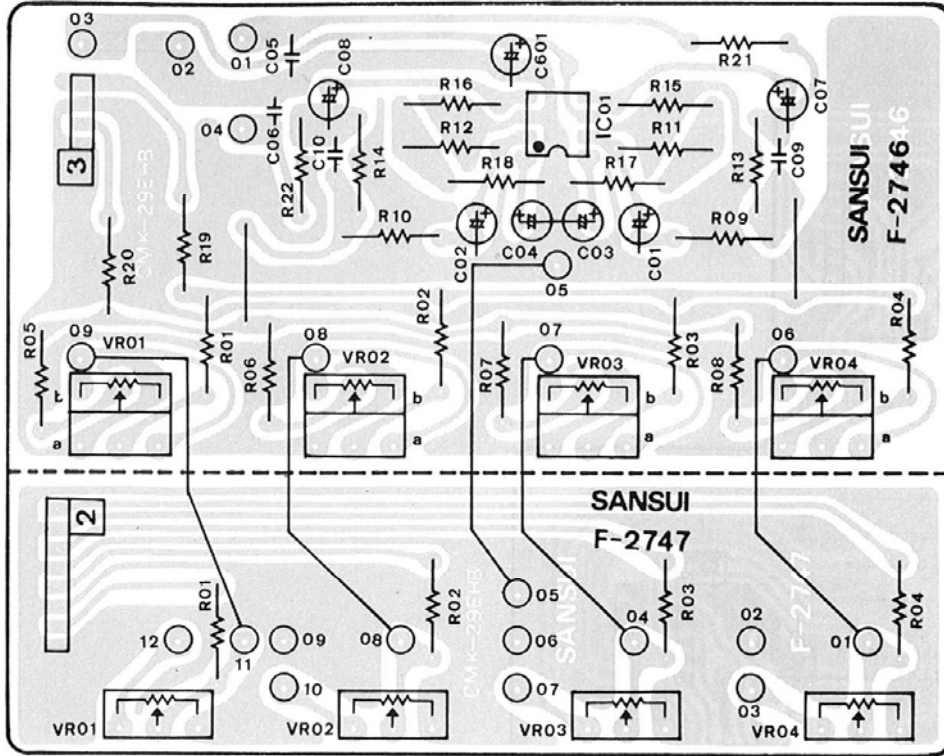

Parts List <F-2746 >

Parts No.	Stock No.	Description
IC01	{ 0360580 0360600 }	{ NE5421 LM-387A } IC
VR01 ~ 04	1015280	250 kΩ A.C.

Parts List <F-2747 >

Parts No.	Stock No.	Description
VR01 ~ 04	{ 1005320 1005321 }	{ 100 kΩ B 100 kΩ B } Level Volume

6) F-2736 Volume Circuit Board (Stock No. 7561981)

Conductor Side

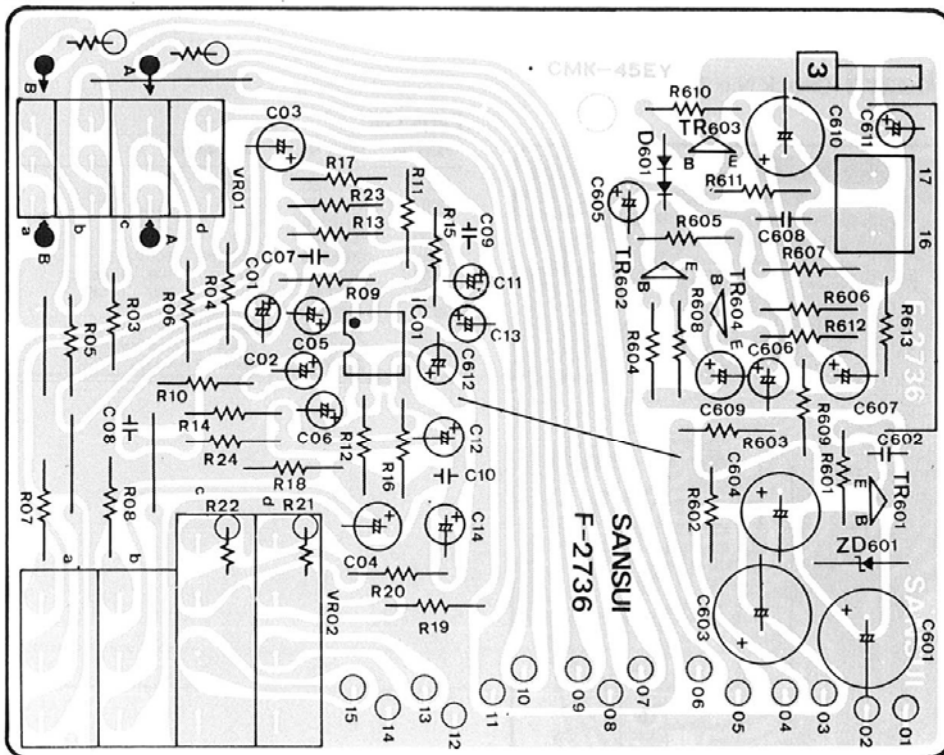

Parts List

Parts No.	Stock No.	Description
TR601	0306131, 2	2SC1364 6, 7
TR602	0305951, 2	2SC945 Q, P
TR603	0305951, 2	2SC945 Q, P
TR604	0300510, 1	2SA733 P, Q
IC01	{ 0360580 0360600 }	{ NE5421 LM-387A } IC
D601	0340120	VD1212 Varistor
R602	0210151	150Ω 1/8W N.I.R.
R603	0210151	150Ω 1/8W N.I.R.
VR01	1065070	50 kΩ A.C x 2
VR02	1060470	(50 kΩ x 2) + (10 kΩ x 2)
	2410910	Type E 2P Pin Ass'y

7) F-2739 Mixing Circuit Board (Stock No. 7561991)

Conductor Side

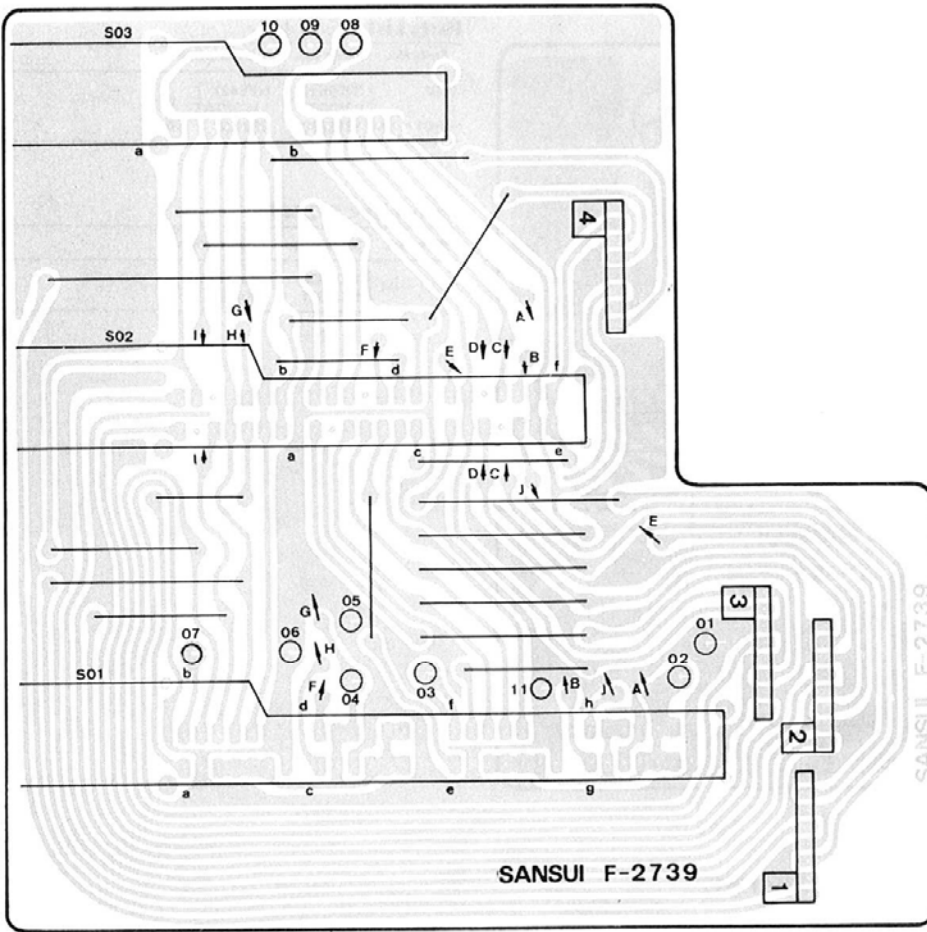

Parts List

Parts No.	Stock No.	Description
S01	1190500	Mixing Selector Switch
S02	1190490	Recording Mode Switch
S03	1190460	Monitor Selector Switch

8) F-2737 Power Supply Circuit Board (Stock N.o 7502521)

Conductor Side

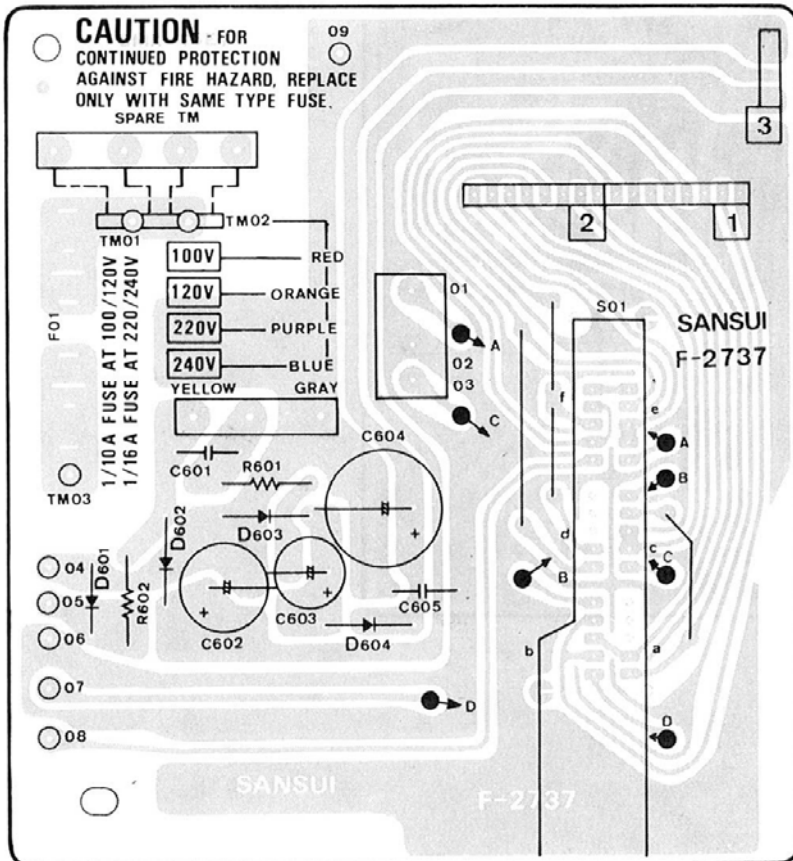

Parts List

Parts No.	Stock No.	Description
D601	0311160	1S2473D
D602	0310340	10D1
D603	0310340	10D1 Diode
D604	0310340	10D1
C601	0655103	10,000 pF 500V C.C.
R601	0191100	10Ω ¼W Fuse R.
R602	0210561	560Ω ¼W N.I.R.
S01	1190480	Adaptor Switch
	2410610	Type A 4P Connector Ass'y
	2410620	Type A 6P Connector Ass'y
	2410920	Type E 3P Pin Ass'y

Abbreviations

C.R.	: Carbon Resistor	E.C.	: Electrolytic Capacitor
S.R.	: Solid Resistor	BP.E.C.:	Bi-Polar Electrolytic Capacitor
Ce.R.	: Cement Resistor		
M.R.	: Metal Film Resistor	C.C.	: Ceramic Capacitor
F.R.	: Fusing Resistor	MI.C.	: Mica Capacitor
N.I.R.	: Non-Inflammable Resistor	O.C.	: Oil Capacitor
		P.C.	: Polystyrene Capacitor
M.C.	: Mylar Capacitor	T.C.	: Tantalum Capacitor

9) F-2738 Adaptor Input & Output Circuit Board (Stock No. 7595491)

Conductor Side

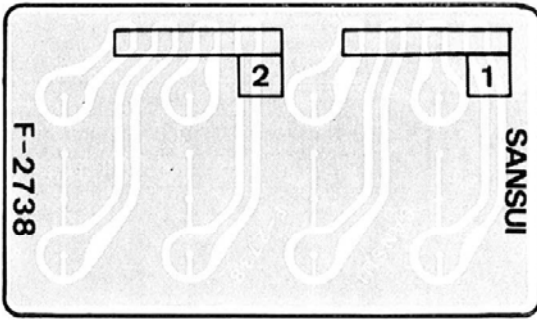

Parts List

Parts No.	Stock No.	Description
	2200480	8P Input & Output Terminal

10) F-2740 Input & Output Circuit Board (Stock No. 7595551)

Conductor Side

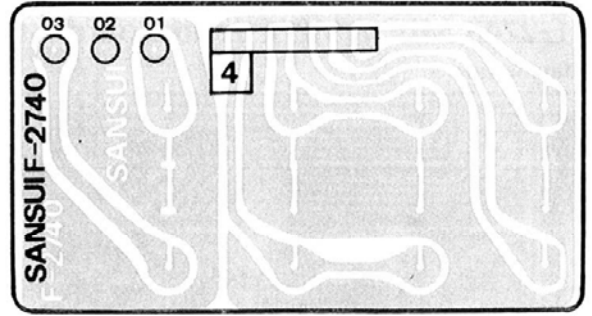

Parts List

Parts No.	Stock No.	Description
	2200480	8P Input & Output Terminal

11) F-2741 Tape Jack Circuit Board (Stock No. 7595511)

Conductor Side

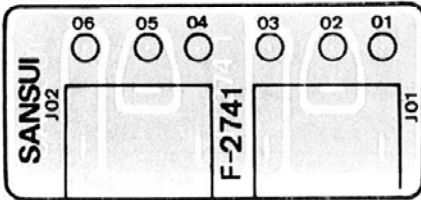

Parts List

Parts No.	Stock No.	Description
J01, 02	2430290	S-G7720 Jack

12) F-2744 Input Selector Circuit Board (Stock No. 7595531)

Conductor Side

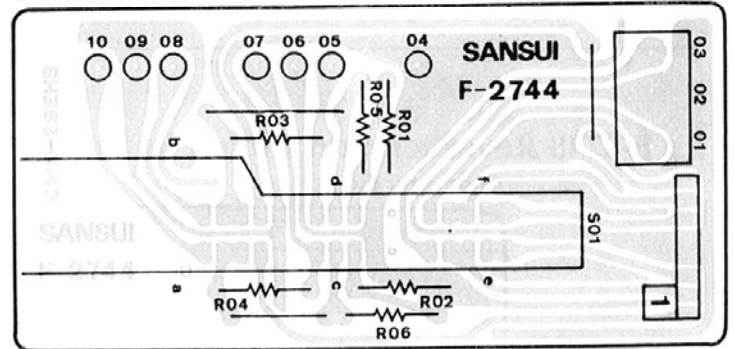

Parts List

Parts No.	Stock No.	Description
	2200490	12P Input & Output Terminal

13) F-2742 Tape Input & Output Circuit Board (Stock No. 7595521)

Conductor Side

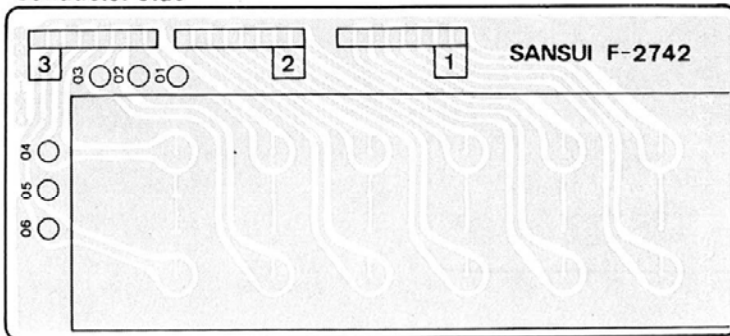

Parts List

Parts No.	Stock No.	Description
S01	1190470	Input Selector Switch
	2410920	Type E 3P Pin Ass'y

● Figures
Connectors & Pin Ass'y

Connectors

Type A (3~10 pins)	Type B (2~6 pins)	Stock No
		2 Pins 2420450
		3 Pins 2420460
		3 Pins (RED) 2420650
		4 Pins 2420470
		5 Pins 2420480
		6 Pins 2420490

NOTE Since stock number of female connectors (type B) with wires are not shown in each parts list of Complete circuit board, please refer to the above parts list when ordering the connector.

Pin Ass'y

Type A (3~10 pins) 	Type B (3~10 pins) 	Type C (3~10 pins)
Type D (2~6 pins) 	Type E (2~6 pins) 	Type F (2~6 pins)

5. SCHEMATIC DIAGRAM

A B C D E F G H

AX-7 AX-7

This presentation of the schematic diagram is not a contract. It is subject to change without notice for improvement. Design and specifications subject to change without notice for improvement.

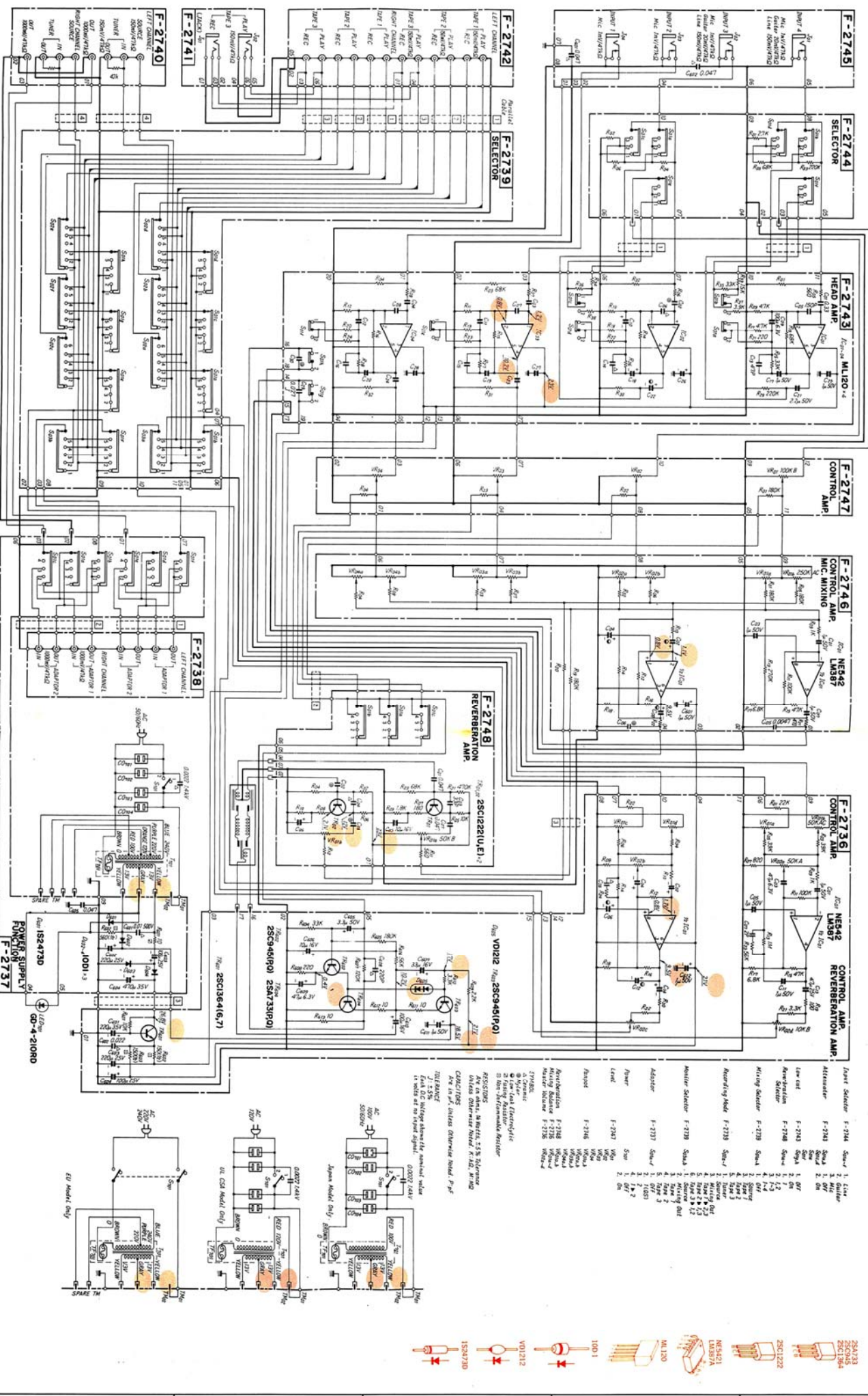

Part Number	Quantity	Description
F-2742	1	Left Channel Selector
F-2743	1	Head Amp
F-2744	1	Selector
F-2745	1	Head Amp
F-2746	1	Control Amp
F-2747	1	Control Amp
F-2748	1	Reverberation Amp
F-2749	1	Control Amp
F-2750	1	Control Amp
F-2751	1	Control Amp
F-2752	1	Control Amp
F-2753	1	Control Amp
F-2754	1	Control Amp
F-2755	1	Control Amp
F-2756	1	Control Amp
F-2757	1	Control Amp
F-2758	1	Control Amp
F-2759	1	Control Amp
F-2760	1	Control Amp
F-2761	1	Control Amp
F-2762	1	Control Amp
F-2763	1	Control Amp
F-2764	1	Control Amp
F-2765	1	Control Amp
F-2766	1	Control Amp
F-2767	1	Control Amp
F-2768	1	Control Amp
F-2769	1	Control Amp
F-2770	1	Control Amp
F-2771	1	Control Amp
F-2772	1	Control Amp
F-2773	1	Control Amp
F-2774	1	Control Amp
F-2775	1	Control Amp
F-2776	1	Control Amp
F-2777	1	Control Amp
F-2778	1	Control Amp
F-2779	1	Control Amp
F-2780	1	Control Amp
F-2781	1	Control Amp
F-2782	1	Control Amp
F-2783	1	Control Amp
F-2784	1	Control Amp
F-2785	1	Control Amp
F-2786	1	Control Amp
F-2787	1	Control Amp
F-2788	1	Control Amp
F-2789	1	Control Amp
F-2790	1	Control Amp
F-2791	1	Control Amp
F-2792	1	Control Amp
F-2793	1	Control Amp
F-2794	1	Control Amp
F-2795	1	Control Amp
F-2796	1	Control Amp
F-2797	1	Control Amp
F-2798	1	Control Amp
F-2799	1	Control Amp
F-2800	1	Control Amp



6. OTHER PARTS

Top View

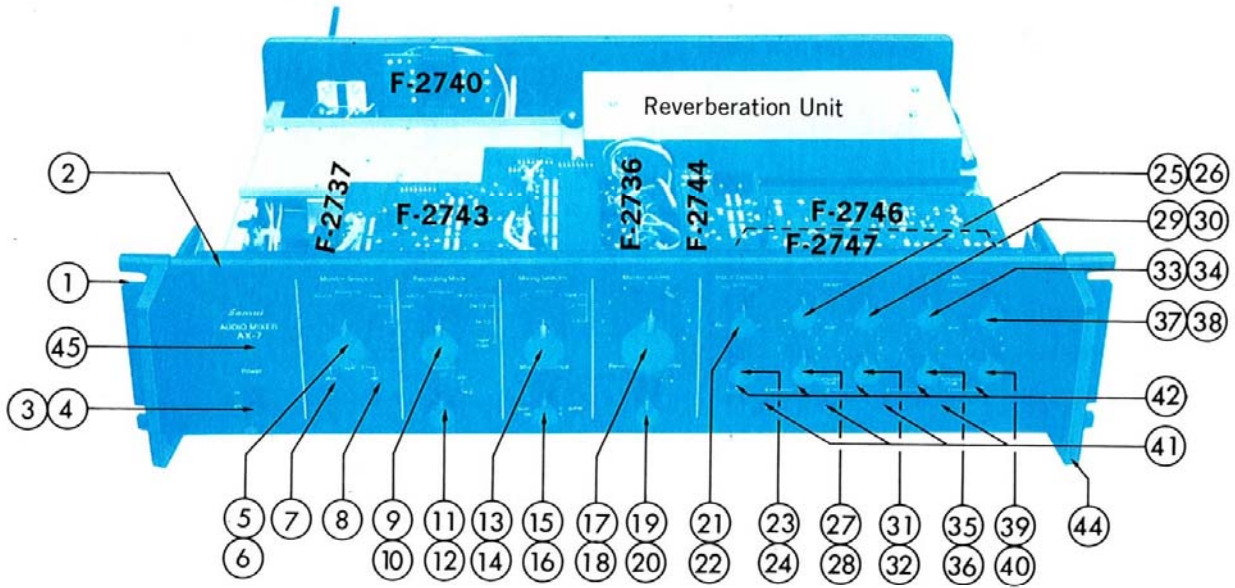

Bottom View

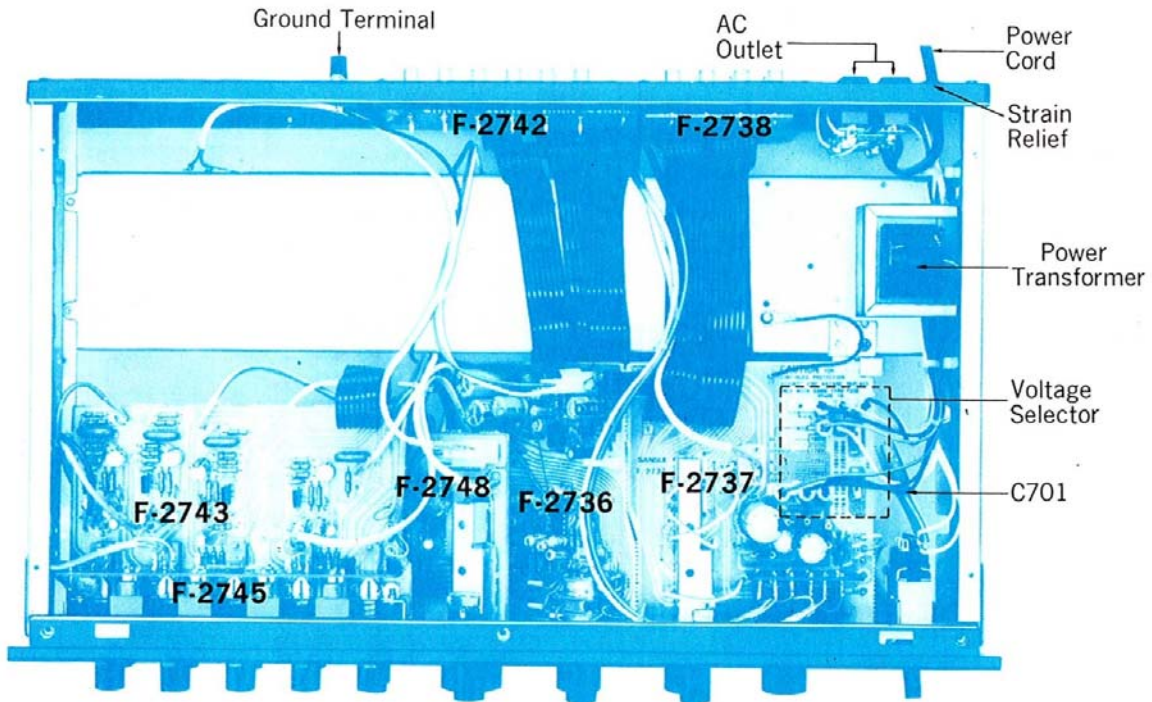

Parts List

Parts No.	Stock No.	Description	Parts No.	Stock No.	Description	Parts No.	Stock No.	Description
1	5396350	Rack Mounting Adaptor	16	5318940	Knob, mixing balance switch	35	1005320, 1	Mic Level Volume (Mic 2), 100 kΩ B
2	7007690	Front Panel Ass'y	17	1060470	Master Volume, 50 kΩ A x 2 + 10 kΩ B x 2	36	5318940	Knob, mic level volume
(45)	0319120	LED GD. 4-210RD	18	5318920	Knob, master volume	37	1015180	Mic Panpot Volume (Mic 1), 250 kΩ AC
	5288930	Knob Guide	19	1190450	Reverberation Selector Switch	38	5318950	Knob, mic panpot
	5305860	Front Panel	20	5318940	Knob, reverberation selector	39	1005320, 1	Mic Level Volume (Mic 1), 100 kΩ B
(42)	5326640	Push Knob	21	1190470	Input Selector Switch	40	5318940	Knob, mic level volume
	5336680	Sansui Mark	22	5318940	Knob, input selector	41	2430310	Mic Jack
	6906480	Spring	23	1015290, 1	Reverberation Volume, 50 kΩ B x 2	42	1131480	Push Switch
3	1171640	Power Switch	24	5318940	Knob, reverberation volume	44	5396350	Rack Mounting Adaptor
4	5326611	Knob, power Switch	25	1015280	Panpot Volume (Mic 4), 250 kΩ AC	45	0319120	LED, power indicator
5	1190460	Monitor Selector Switch	26	5318950	Knob, Panpot Switch	C701	0659803	0.0022 μF 150V C.C.
6	5318930	Knob, Monitor Selector	27	1005320, 1	Level Volume (Mic 4), 100 kΩ B		4350010	Reverberation Unit
7	2430290	Tape Play Jack	28	5318940	Knob, level volume		2230150	Ground Terminal
8	2430290	Tape Rec Jack	29	1015280	Panpot Volume (Mic 3), 250 kΩ AC		2450060	AC Outlet
9	1190490	Recording Mode Switch	30	5318950	Knob, panpot volume		3800290	Power Cord
10	5318930	Knob, recording mode switch	31	1005320	Level Volume (Mic 3), 100 kΩ B		3910600	Strain Relief
11	1190480	Adaptor Switch	32	5318940	Knob, level volume		4002610	Power Transformer
12	5318940	Knob, adaptor switch	33	1015280	Mic Panpot Volume (Mic 2), 250 kΩ AC		5058800	Bottom Plate
13	1190500	Mixing Selector Switch	34	5318950	Knob, mic panpot		5507070	Leg
14	5318930	Knob, mixing selector						
15	1065070	Mixing Balance Volume, 50 kΩ A C x 2						

7. PACKING LIST

Parts No.	Stock No.	Description
1	9116640	Vinyl Cover
2	9028100	Stylofoam Packing
3	9009800	Carton Case
4	5996080	Curl Stopper

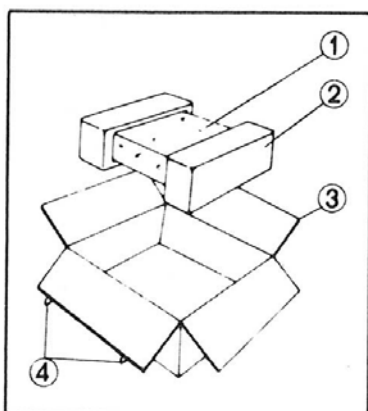

8. ACCESSORY PARTS LIST

Parts No.	Stock No.	Description
	9203180	Operating Instructions
	3810280	PJP Connecting Cord
	5396350	Rack Mounting Adaptor (each)
	9237620	Schematic Diagram

MEMO



SANSUI ELECTRONICS CORPORATION: 55-11 Queens Blvd. Woodside, N.Y. 11377 U.S.A.
333 West Alondra Blvd. Gardena, California 90247 U.S.A.
3036 Koapaka St. Honolulu, Hawaii 96819 U.S.A.

SANSUI AUDIO EUROPE N.V.: North Trade Bldg (9th floor) Noorderlaan 133-Bus 1,2030 Antwerp, Belgium
SANSUI AUDIO EUROPE S.A.: Arabella center, 6 Frankfurt AM Main, Lyoner Strasse 44-48, West Germany

SANSUI ELECTRIC COMPANY LTD.: 14-1, Izumi 2-chome, Suginamiku, Tokyo 168 Japan PHONE: (03) 323-1111/TELEX:232-2076

SM087

Printed in Japan (870720M)