

SERVICE MANUAL

POWER AMPLIFIER **SANSUI BA-5000**



Sansui

SANSUI ELECTRIC CO., LTD.

This service manual is designed for service engineers to repair, adjust, maintain and order the replacement parts of the BA-5000 correctly. When ordering the parts, use the stock number and parts name specifically referring to the Parts Locations & Parts Lists. For general usage and maintenance of the unit, please refer to the Operating Instructions attached with the unit.

TABLE OF CONTENTS

<u>Section</u>	<u>Title</u>	<u>Page</u>
1.	SPECIFICATIONS	2
2.	BLOCK DIAGRAM	2
3.	ADJUSTMENTS	3
3-1.	Driver Circuit Board Adjustments.....	3
3-2.	Power Meter Adjustment	3
4.	PARTS LOCATIONS AND PARTS LISTS	4
4-1.	F-2520 Buffer Amplifier Circuit Board	4
4-2.	F-2518 Driver Circuit Board.....	5
4-3.	F-2521 Power Supply Circuit Board (Low Voltage)	6
4-4.	F-2519 Power Supply Circuit Board	7
4-5.	F-2515 Meter Amplifier Circuit Board	7
4-6.	F-2517 Connector Circuit Board.....	8
4-7.	F-2516 Connector Circuit Board.....	8
4-8.	F-2506 Input Terminal Circuit Board.....	8
4-9.	F-2514 Meter Lamp Circuit Board	8
5.	FIGURES, CONNECTOR & PIN Ass'y	9
5-1.	Transistor & IC	9
5-2.	Diode	9
5-3.	Connector & Pin Ass'y	9
6.	POWER SUPPLY VOLTAGE CHANGEOVER	9
7.	OTHER PARTS (Front Side)	10
8.	TROUBLESHOOTING CHART	11
8-1.	Operation Block Diagram	11
8-2.	Main Troubleshooting on Each Section.....	11
9.	OTHER PARTS (Top, Bottom Side)	12
10.	SCHEMATIC DIAGRAM	13
11.	PACKING LIST	14
12.	ACCESSORY PARTS LIST	14

1. SPECIFICATIONS

POWER OUTPUT

Min. RMS, both channels driven, from 20 to 20,000Hz, with no more than 0.1% total harmonic distortion in stereo operation

- 300 watts per channel into 2 ohms
- 300 watts per channel into 4 ohms
- 300 watts per channel into 8 ohms

Min. RMS, both channels driven, at 1,000Hz, with no more than 0.1% total harmonic distortion in stereo operation.

- 320 watts per channel into 2 ohms
- 320 watts per channel into 4 ohms
- 320 watts per channel into 8 ohms

Min. RMS, from 20 to 20,000Hz, with no more than 0.1% total harmonic distortion in mono operation.

- 600 watts into 4 ohms
- 600 watts into 8 ohms
- 600 watts into 16 ohms

Min. RMS, at 1,000Hz, with no more than 0.1% total harmonic distortion in mono operation.

- 640 watts into 4 ohms
- 640 watts into 8 ohms
- 640 watts into 16 ohms

LOAD IMPEDANCE

- In stereo operation 2, 4, 8 ohms
- In mono operation 4, 8, 16 ohms

POWER BANDWIDTH 20 to 20,000Hz at or below rated min. RMS, power output and total harmonic distortion

TOTAL HARMONIC DISTORTION less than 0.1% at or below rated min. RMS power output

INTERMODULATION DISTORTION (70Hz : 7,000Hz = 4 : 1 SMPTE method) less than 0.1%

FREQUENCY RESPONSE (at 1 watt) 15Hz to 30kHz ± 2 dB

DAMPING FACTOR approximately 10 at 8 ohms load

CHANNEL SEPARATION (at rated output, 1kHz) better than 60dB

HUM AND NOISE (IHF) better than 100dB

INPUT SENSITIVITY AND IMPEDANCE (1kHz, for rated output) . . 700mV 50kilo-ohms

GENERAL

POWER VOLTAGE 100, 120, 220, 240V 50/60Hz
120V (Usable 110—130V)
(for U.S.A. & Canada only)

POWER CONSUMPTION . . 1,350 watts (max.)
490 watts (rated)

DIMENSIONS 482mm (19") W
222mm (8 3/4") H
466mm (18 1/2") D

WEIGHT 49kg (108.0 lbs.) net
56kg (123.5 lbs.) packed

2. BLOCK DIAGRAM

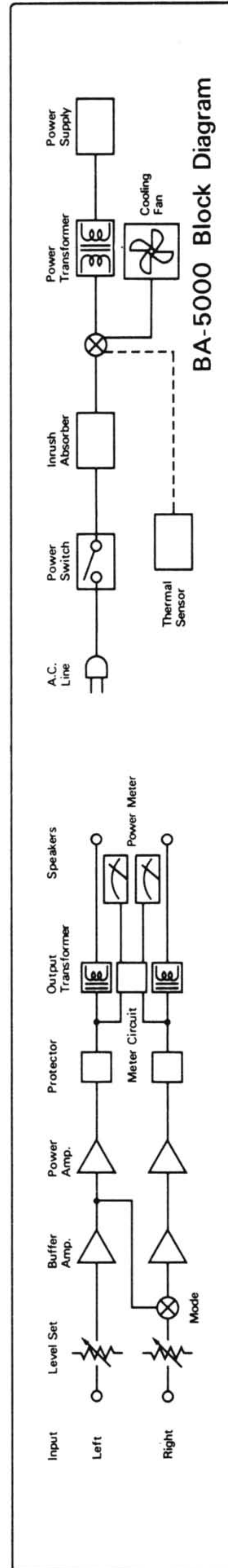

* Design and specifications subject to change without notice for improvements.

3. ADJUSTMENTS

3-1. Driver Circuit Board Adjustments (See Fig. 3-1)

- Note:**
1. Master Volume.....Minimum
 2. Speaker Terminal..... 8Ω
 3. Room Temperature..... $23^{\circ}\pm 5^{\circ}\text{C}$
 4. For adjustment, run the unit for more than 3 minutes after then power is switched on.

STEP	SUBJECT	EQUIPMENT	MEASURE OUTPUT	ADJUST	ADJUST FOR
1.	Bias Current L-CH	milliammeter	F-2516 Fig. 3-1	F-2518 VR01 (Fig. 3-1)	180mA \pm 1mA
2.	Bias Current R-CH	milliammeter	F-2516 Fig. 3-1	F-2518 VR01 (Fig. 3-1)	180mA \pm 1mA

* Take the wires off from power supply section on F-2516. as Fig. 3-1 then set bias current to 180mA.

Note: Milliammeter Polarity: \oplus side—the wire
: \ominus side—Tap of F-2516

* For confirming the bias current, 180mA run the unit other more then 15 minutes after checking all functions of the unit.

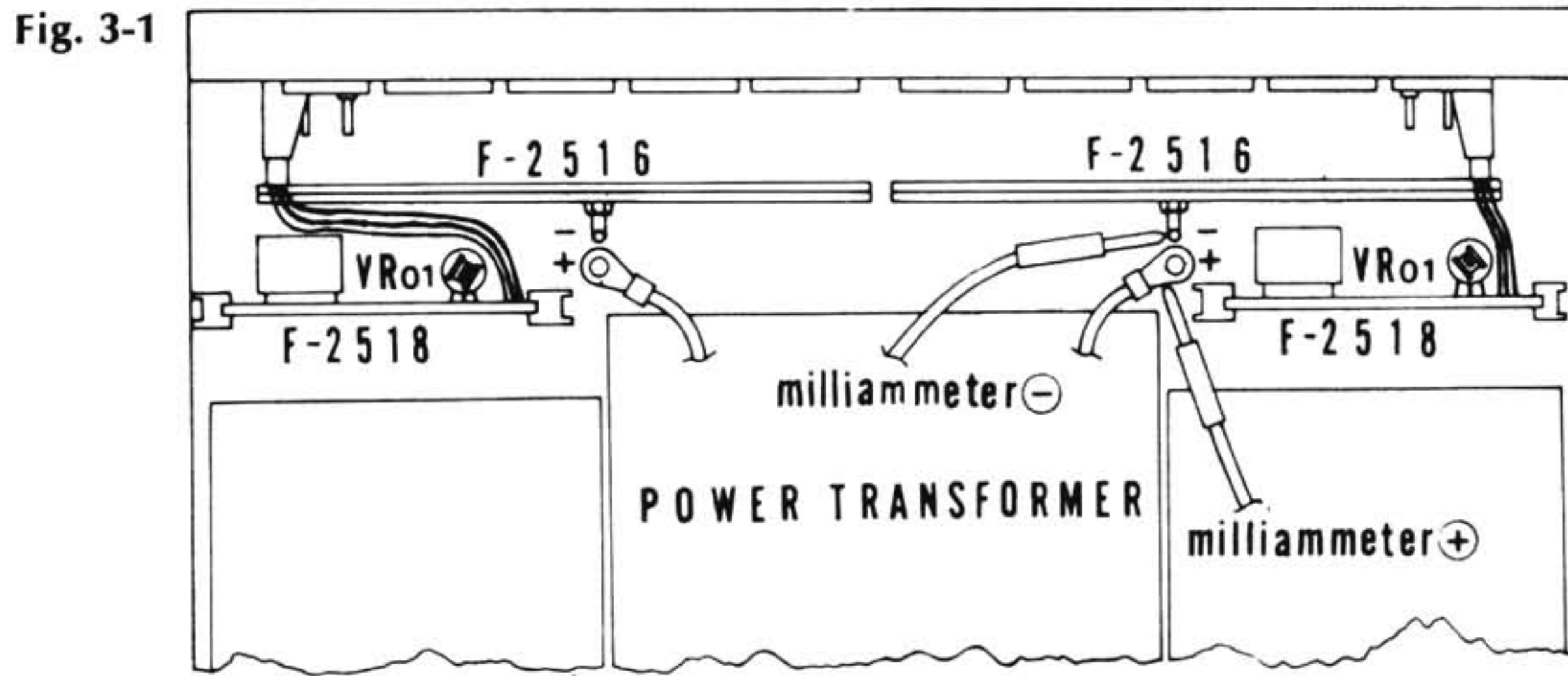

3-2. Power Meter Adjustment

- Note:**
1. Room temperature..... $23\pm 5^{\circ}\text{C}$
 2. Level Volume.....Max.
 3. Input signal.....Sine Wave (1kHz)
 4. For adjustment, run the unit for more than 5 minutes after then power is switched on.

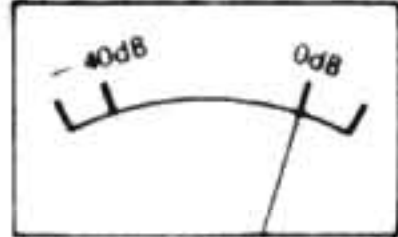
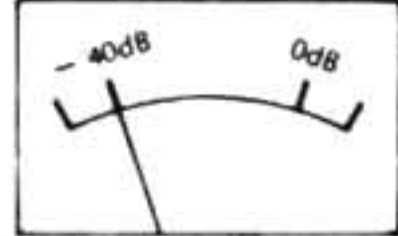
STEP	SUBJECT	OUTPUT LEVEL	ADJUST	METER POSITION	CONDITION
1.	Power Meter Adjustment	49V (8Ω) (0dB)	F-2515 VR02 (Fig. 3-2)	0dB 	VR01 Center
2.	Power Meter Adjustment	490mV (-40dB)	F-2515 VR01 (Fig. 3-2)	-40dB 	

* Confirm the Step 1 again. If the meter position is not within $0\text{dB}\pm 1\text{dB}$, repeat from Step 1 and Step 2.

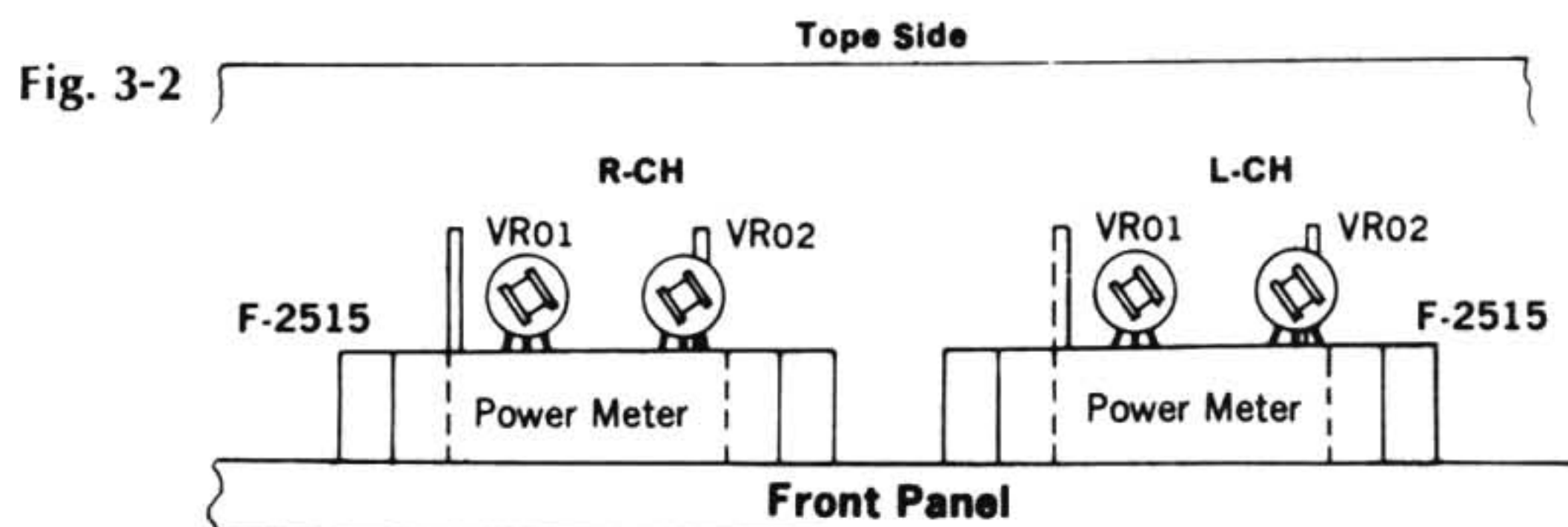

4. PARTS LOCATIONS AND PARTS LISTS

4-1. F-2520 Buffer Amplifier Circuit Board (Stock No. 7592750 Complete Circuit Board F-2520)

Conductor Side

Parts List

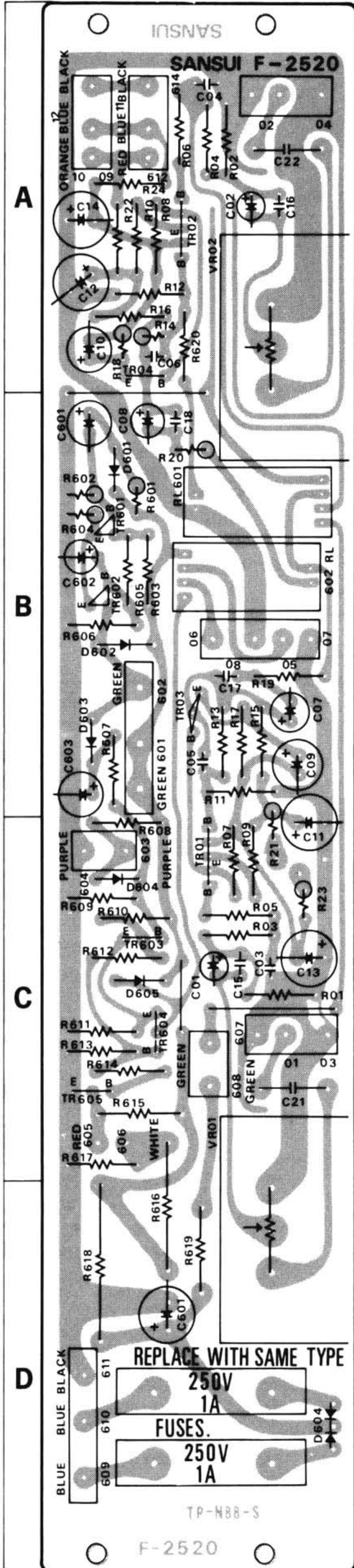

Parts No.	Stock No.	Description	Position
TR01, 02	0360290, 1	2SA798 (F, G) IC	C. A
TR03, 04	0306070, 1	2SC1313 (F G)	B. A
TR601	0306131-3	2SC1364 (6,7,8)	B
TR602	0306131-3	2SC1364 (6,7,8)	B
TR603	0306131-3	2SC1364 (6,7,8)	C
TR604	0306131-3	2SC1364 (6,7,8)	C
TR605	0306131-3	2SC1364 (6,7,8)	C
D601	0311160	1S2473D	B
D602	0310340	10D-1 (1S2226)	B
D603	0311160	1S2473D	B
D604	0311160	1S2473D	C
D605	0310340	10D-1 (1S2226)	C
D606	0310530	1S1850	C
C01, 02	0519101	1 μ F 50V E.C.	C. A
C03, 04	0660101	100 pF	C. A
C05, 06	0660509	5 pF } 50V C.C.	B. A
C07, 08	0519001	10 μ F 25V E.C.	B
C09, 10	0510101	100 μ F 6.3V E.C.	B. A
C11, 12	0512221	220 μ F 16V E.C.	B, C, A, C
C13, 14	0512221	220 μ F 16V E.C.	C. A
C15, 16	0601107	0.01 μ F } 50V M.C.	C. A
C17, 18	0601107	0.01 μ F } 50V M.C.	B
C601	0513100	10 μ F 25V E.C.	B
C602	0510470	47F μ F 6.3V E.C.	B
C603	0513100	10 μ F 25V E.C.	B
C604	0516470	47 μ F 6.3V E.C.	B
C901	0516339	3.3 μ F 63V E.C.	B
R01, 02	0107124	120k Ω	C. A
R03, 04	0107472	4.7k Ω	C. A
R05, 06	0107472	4.7k Ω	C. A
R07, 08	0107223	22k Ω	C. A
R09, 10	0107104	100k Ω	C. A
R11, 12	0107153	15k Ω	B. A
R13	0107223	22k Ω	B
R14	0106223	22k Ω	A
R15, 16	0107103	10k Ω	B. A
R17	0107471	470 Ω	A
R18	0106471	470 Ω	A
R19	0107221	220 Ω	B
R20	0106221	220 Ω	B
R21	0106221	220 Ω	B
R22	0107221	220 Ω	A
R23	0106221	220 Ω	C
R24	0107221	220 Ω	A
R601	0106273	27k Ω	B
R602	0106272	2.7k Ω	A
R603	0107123	12k Ω	B
R604	0106150	15 Ω	B
R605	0107472	4.7k Ω	B
R606	0107153	15k Ω	B
R607	0107104	100k Ω	B
R608	0107333	33k Ω	C
R609	0107104	100k Ω	C
R611	0107150	15 Ω	C
R612	0107472	4.7k Ω	C
R613	0107153	15k Ω	C
R614	0107122	1.2k Ω	C
R615	0103182	1.8k Ω $\frac{1}{2}$ W C.R.	C
R616	0182561	560 Ω 2 W Ce.R.	C, D
R617	0107221	220 Ω $\frac{1}{4}$ W C.R.	C
R618	0135271	270 Ω 5 W Ce.R.	D
R619	0103222	2.2k Ω $\frac{1}{2}$ W C.R.	D
R620	0107223	22k Ω	A
R901	0107563	56k Ω	C
R902	0107563	56k Ω	C
R903	0107273	27k Ω	C
RL601	1150320	10MA 1600 Ω Relay	B
RL602	1150320		
VR01	1090160	100k Ω (B) Semi-Variable Resistor	C, D
VR02	1090160		
2410650	2P (D Type)	Pin Ass'y	C
2410580	3P (D Type)		
2410590	4P (D Type)		

4-2. F-2518 Driver Circuit Board (Stock No. 7571130 Complete Circuit Board F-2518)

Conductor Side

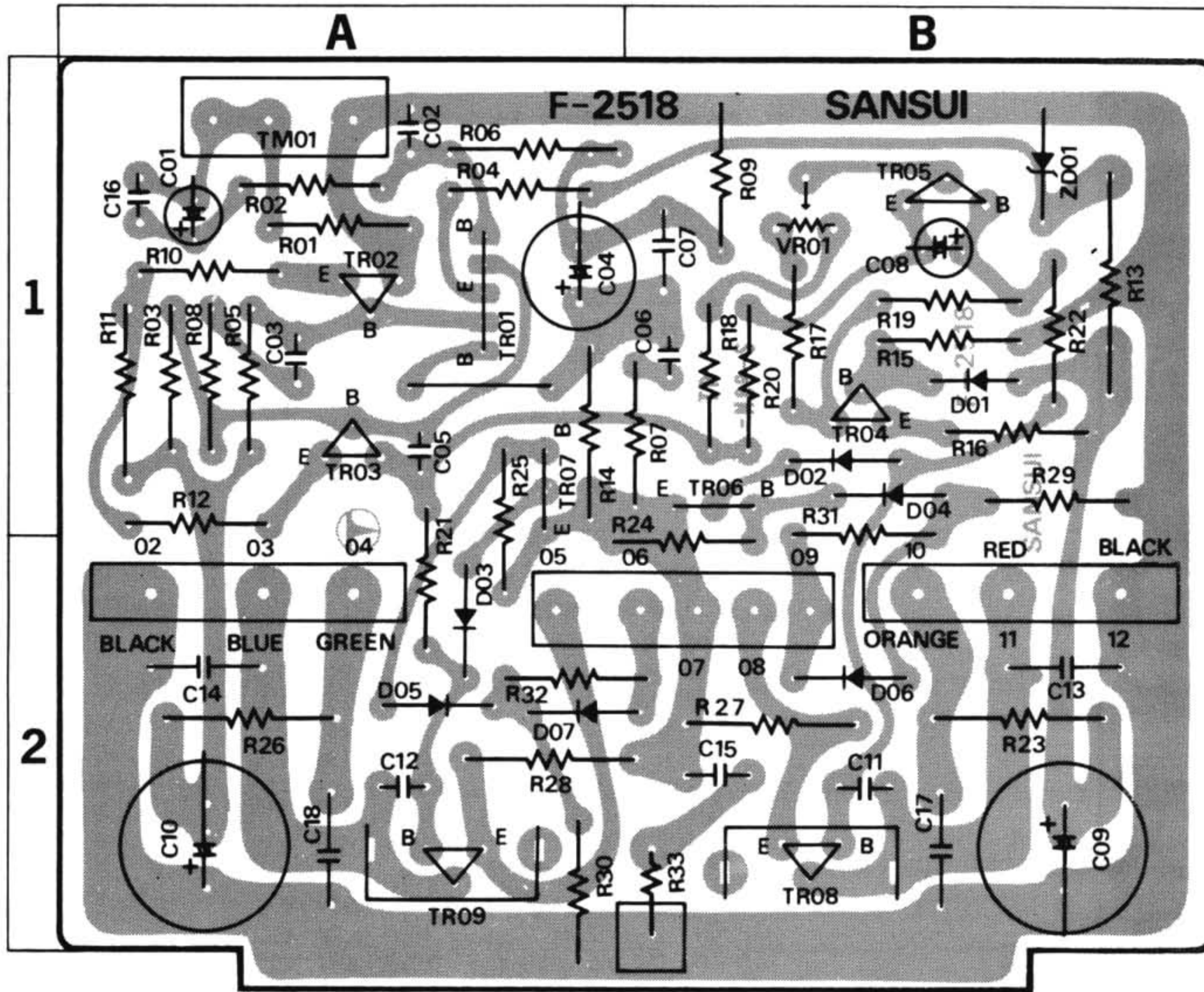

* Please note the followings when replacing transistors TR02, 03, 08, 09. In case that you use 2SC1628 (O) as TR02 for repair, use 2SC1628 (O) as TR03, or 2SC1628 (Y) as TR02 to 2SC1628 (Y) as TR03. Also, in case of using 2SD381 (M) as TR08, use 2SB536 (M) as TR09, or 2SD381 (L) as TR08 to 2SB536 (L) as TR09.

Parts List

Parts No.	Stock No.	Description	Position	Parts No.	Stock No.	Description	Position
TR01	0360290, 1	2SA798 (F, G) I.C.	1 A	C17	0659011	0.01F μ 500V C.C.	2 B
TR02	0306260	2SC1628 (O)	1 A	C18	0659011	0.01 μ F 500V C.C.	2 A
	or	or		C901	0660509	5pF	50V C.C.
	0306261	2SC1628 (Y)		C902	0657102	1000pF	
0306260	2SC1628 (O)	C903	0657102	1000pF			
TR03	or	or	1 A	R01	0107103	10k Ω	1 A
	0306261	2SC1628 (Y)		R02	0107103	10k Ω	
TR04	0300700, 1	2SA818 (O, Y)	1 B	R03	0107332	3.3k Ω	1 A
TR05	0305871, 2	2SC984 (B, C)	1 B	R04	0107222	2.2k Ω	1 A
TR06	0305951, 2	2SC945 (Q, P)	1 B	R05	0107332	3.3k Ω	1/4 W C.R.
TR07	0300510, 1	2SA733 (P, Q)	1 A	R06	0107333	33k Ω	
TR08	0308531	2SD381 (M)	2 B	R07	0107473	47k Ω	1 B
	or	or		R08	0107221	220 Ω	1 A
	0308532	2SD381 (L)		R09	0107222	2.2k Ω	1 B
TR09	0303371	2SB536 (M)	2 B	R10	0107820	82 Ω	1 A
	or	or		R11	0103391	390 Ω	1/2 W C.R.
	0303372	2SB536 (L)		R12	0107820	82 Ω	1/4 W C.R.
D01	0340120	VD1212 Varistor	1 B	R13	0104472	4.7k Ω	1 W C.R.
D02	0311160	1S2473D	1 B	R14	0107333	33k Ω	1 A
D03	0311160	1S2473D	2 A	R15	0107473	47k Ω	1 B
D04	0311160	1S2473D	1 B	R16	0107820	82 Ω	1 B
D05	0311160	1S2473D	2 A	R17	0107152	1.5k Ω	1 B
D06	0311160	1S2473D	2 B	R18	0107271	270 Ω	1/4 W C.R.
D07	0311160	1S2473D	2 A, B	R19	0107560	56 Ω	
ZD01	0316230	RD-9.1EB Zener Diode	1 B	R20	0107270	27 Ω	1 B
C01	0519105	2.2 μ F 50V E.C.	1 A	R21	0107561	560 Ω	1, 2 A
C02	0660101	100pF	1 A	R22	0107471	470 Ω	1 B
C03	0657102	1000pF	1 A	R23	0103221	220 Ω	1/2 W C.R.
C04	0510221	220 μ F 6.3V E.C.	1 A, B	R24	0107471	470 Ω	1, 2 B
C05	0660220	22pF	1 A	R25	0107471	470 Ω	1/4 W C.R.
C06	0660509	5pF	1 B	R26	0103221	220 Ω	2 A
C07	0601108	0.1 μ F 50V M.C.	1 B	R27	0103561	560k Ω	1/2 W C.R.
C08	0515109	1 μ F 50V E.C.	1 B	R28	0103561	560k Ω	2 A, B
C09	0519903	100 μ F	2 B	R29	0107333	33k Ω	1 B
C10	0519903	100 μ F	2 A	R30	0107333	33k Ω	1/4 W C.R.
C11	0660101	100pF	2 B	R31	0107151	150 Ω	
C12	0660101	100pF	2 A	R32	0107151	150 Ω	2 A, B
C13	0659011	0.01 μ F	2 B	R33	0152100	10 Ω	2 W Ce.R.
C14	0659011	0.01 μ F	2 A	VR01	1035280	330 Ω (B) Semi-Variable Resistor	1 B
C15	0601477	0.047 μ F 50V M.C.	2 B		2410570	5P (D Type)}	Pin Ass'y
C16	0601107	0.01 μ F 50V M.C.	1 A		2410580	3P (D Type)}	

4-3. F-2521 Power Supply Circuit Board (Low Voltage)

(Stock No. 7501140 Complete Circuit Board F-2521)

Conductor Side

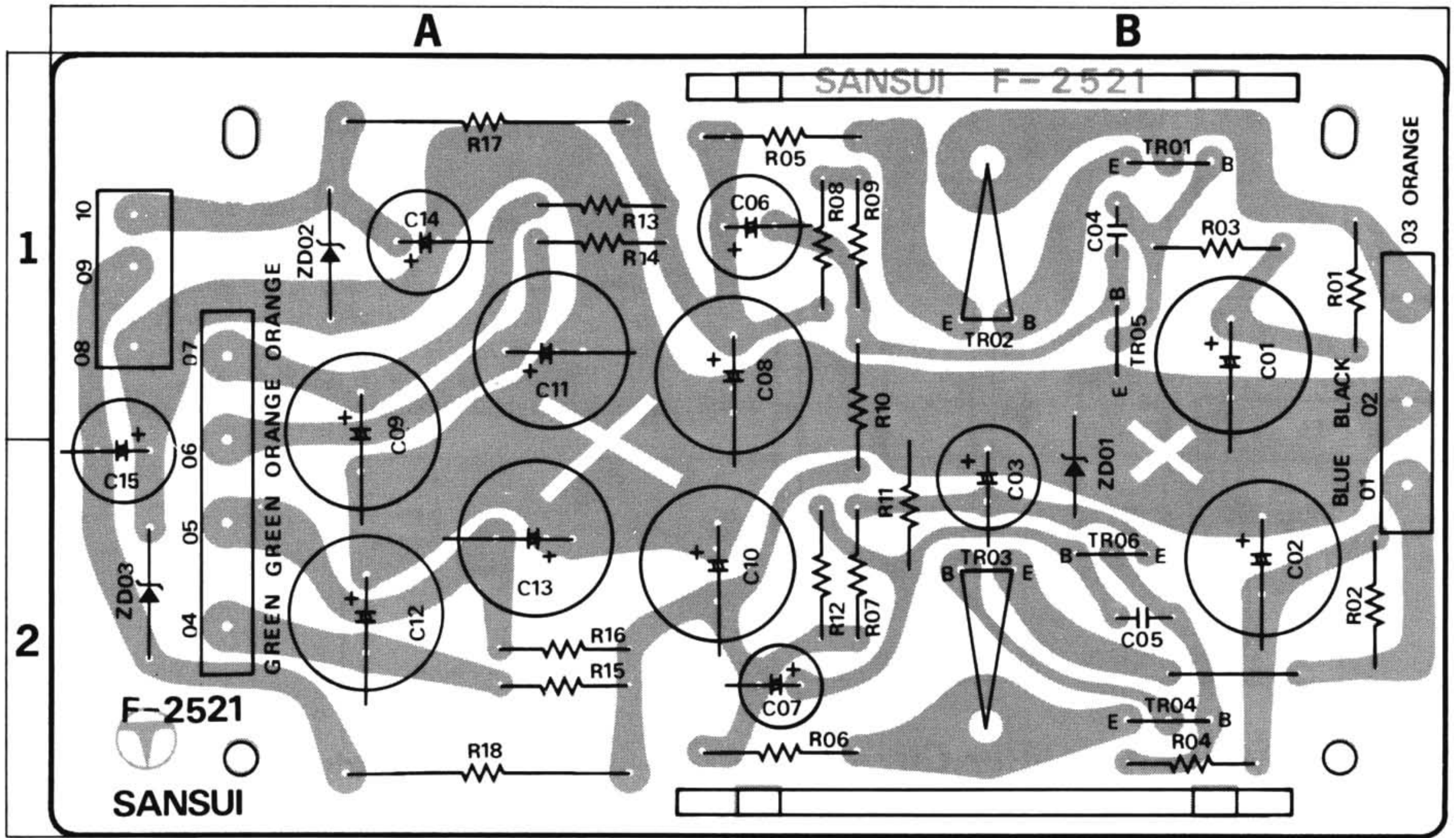

Parts List

Parts No.	Stock No.	Description	Position	Parts No.	Stock No.	Description	Position	
TR01	0306280, 1	2SC1735 (C, D)	} Transistor	R06	0103150	15Ω ½W Ce.R.	2 A, B	
TR02	0308441, 2	2SD382 (M, L)		R07	0107682	6.8kΩ	2 B	
TR03	0308441, 2	2SD382 (M, L)		R08	0107223	22kΩ	1 B	
TR04	0300720, 1	2SA850 (C, D)		R09	0107103	10kΩ	1 B	
TR05	0306270, 1	2SC1708 (F, G)		R10	0107333	33kΩ	1, 2 B	
TR06	0300710, 1	2SA847 (F, G)		R11	0107103	10kΩ	} ¼W C.R.	
ZD01	0316510	RD24E	} Diode	R12	0107153	15kΩ		2 B
ZD02	0315620	EQB01-15		R13	0107150	15Ω		1 A
ZD03	0315620	EQB01-15		R14	0107150	15Ω	1 A	
C01	0519903	100μF } 80V E.C.	1, 2 B	R15	0107150	15Ω	2 A	
C02	0519903	100μF } 80V E.C.	2 B	R16	0107150	15Ω	2 A	
C03	0513101	100μF 25V E.C.	1, 2 B	R17	0185102	1kΩ 5W Ce.R.	1 A	
C04	0660471	470pF } 50V C.C.	1 B	R18	0185102	1kΩ 5W Ce.R.	2 A	
C05	0660471	470pF } 50V C.C.	2 B		2410650	2P (D Type)	} Pin Ass'y	
C06	0519404	10μF 100V E.C.	1 A		2410580	3P (D Type)		
C07	0515100	10μF 50V E.C.	2 A, B					
C08	0519903	100μF	1, 2 A					
C09	0519903	100μF	1, 2 A					
C10	0519903	100μF } 80V E.C.	2 A					
C11	0519903	100μF } 80V E.C.	1 A					
C12	0519903	100μF } 80V E.C.	2 A					
C13	0519903	100μF } 80V E.C.	2 A					
C14	0512221	220μF 35V E.C.	1 A					
C15	0512221	220μF 25V E.C.	1, 2 A					
R01	0107103	10kΩ	1 B					
R02	0107103	10kΩ	2 B					
R03	0107682	6.8kΩ	} ¼W C.R.					
R04	0107682	6.8kΩ		2 B				
R05	0103150	15Ω ½W C.R.	1 A, B					

4-4. F-2519 Power Supply Circuit Board (Stock No. 7501130 Complete Circuit Board F-2519)

Conductor Side

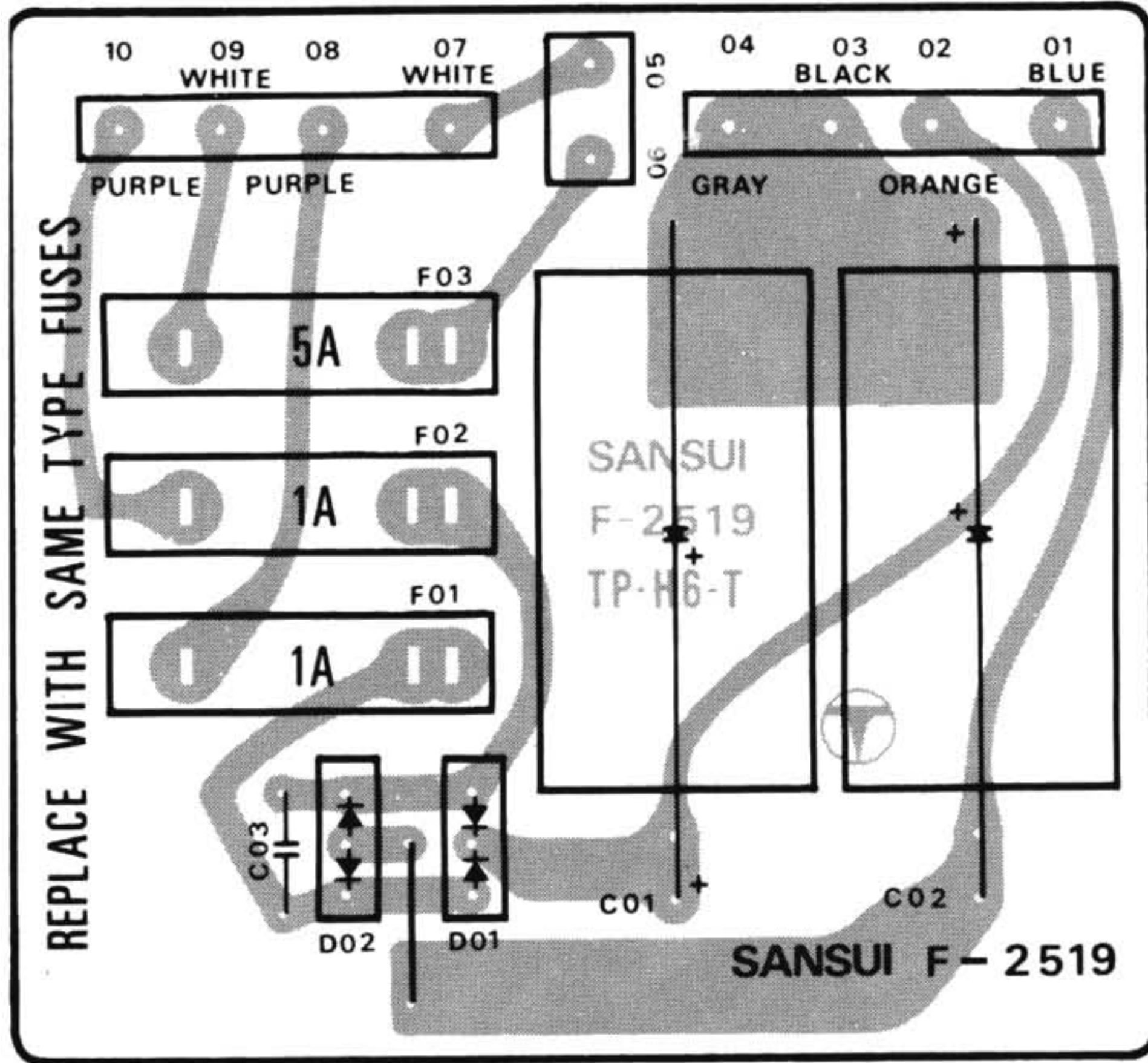

Parts List

Parts No.	Stock No.	Description	Position
D01	0310530	1S1850	Diode
D02	0310540	1S1850R	
C01	0507331	330 μ F	100V E.C.
C02	0507331	330 μ F	
F01	0431222	1A 250V 6.35 \times 30MM	Fuse
F02	0431222	1A 250V 6.35 \times 30MM	
F03	0431280	Fuse	
	2410650	2P (D Type) Pin Ass'y	

4-5. F-2515 Meter Amplifier Circuit Board (Stock No. 7592720 Complete Circuit Board F-2515)

Conductor Side

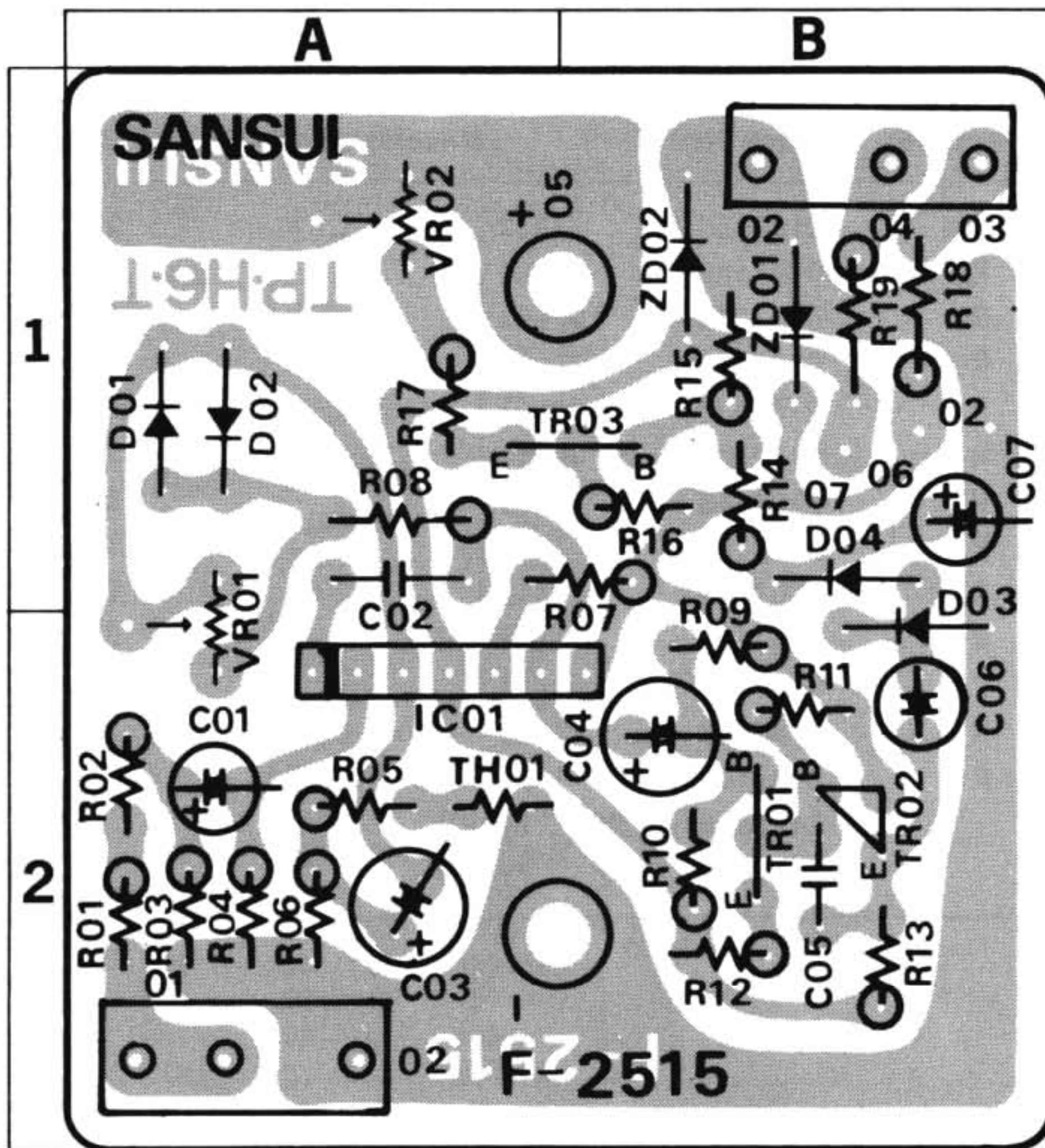

Parts List

Parts No.	Stock No.	Description	Position	
TR01	0305951, 2	2SC945 (Q, P)	2 B	
TR02	0305951, 2	2SC945 (Q, P)		
TR03	0306071 or 0306091	2SC1313R (G) or 2SC1312R (G)	Transistor	
				1 A, B
IC01	0360280	TA-7136P IC	2 A	

Parts No.	Stock No.	Description	Position
D01	0340120	VD1212	1 A
D02	0340120	VD1212	
D03	0311160	1S2473D	Diode
D04	0311160	1S2473D	
TH01	0320030	31D27 Thermistor	2 A
C01	0515109	1 μ F 50V E.C.	2 A
C02	0660330	33 pF 50V C.C.	1 A
C03	0513100	10 μ F	25V E.C.
C04	0513100	10 μ F	
C05	0660151	150 pF 50V C.C.	2 B
C06	0535109	1 μ F 50V E.C.	2 B
C07	0573688	0.68 μ F 35WV T.C.	1 B
C901	0660330	33 pF 50V C.C.	
R01	0106153	15k Ω	1/4 W C.R.
R02	0106103	10k Ω	
R03	0106101	100 Ω	
R04	0106154	150k Ω	
R05	0106102	1k Ω	
R06	0106272	2.7k Ω	
R07	0106104	100k Ω	
R08	0106821	820 Ω	
R09	0106474	470k Ω	
R10	0106563	56k Ω	
R11	0106183	18k Ω	
R12	0106332	3.3k Ω	
R13	0106392	3.9k Ω	
R14	0106684	680k Ω	
R15	0106474	470k Ω	
R16	0106182	1.8k Ω	
R17	0106331	330 Ω	
R901	0107681	680 Ω	
VR01	1035490	1M Ω (B)	Semi-Variable Resistor
VR02	1035310	1k Ω (B)	
	2410670	3P (F Type) Pin Ass'y	1 A

4-6. F-2517 Connector Circuit Board (Stock No. 7592740 Complete Circuit Board F-2517)

Conductor Side

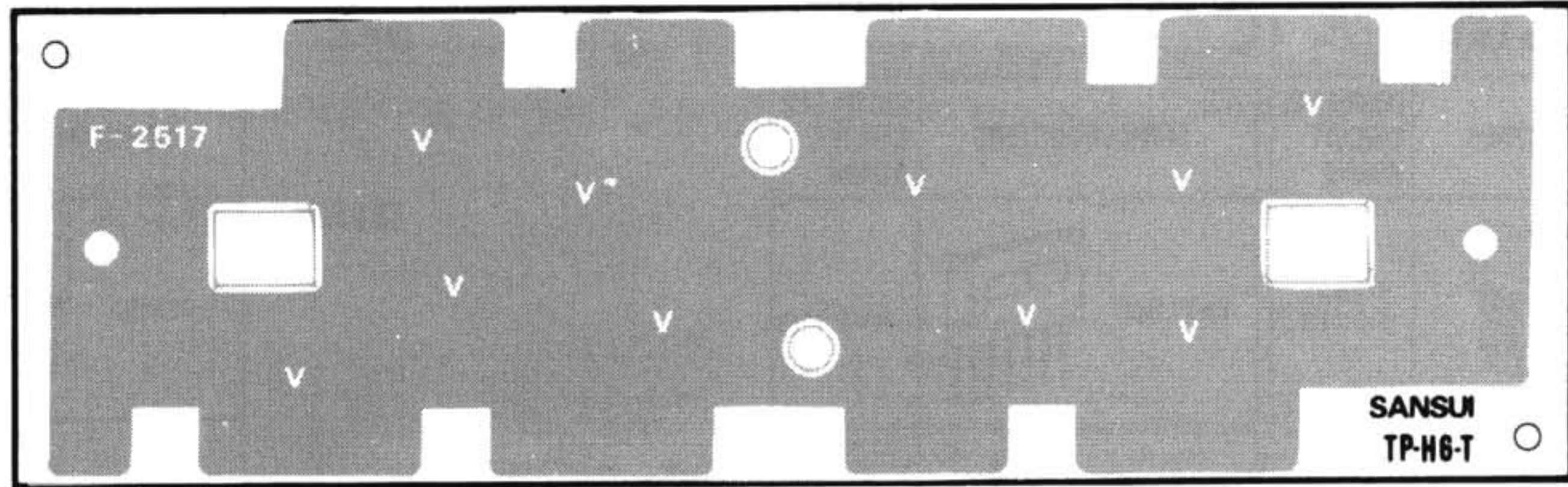

4-7. F-2516 Connector Circuit Board (Stock No. 7592730 Complete Circuit Board F-2516)

Conductor Side

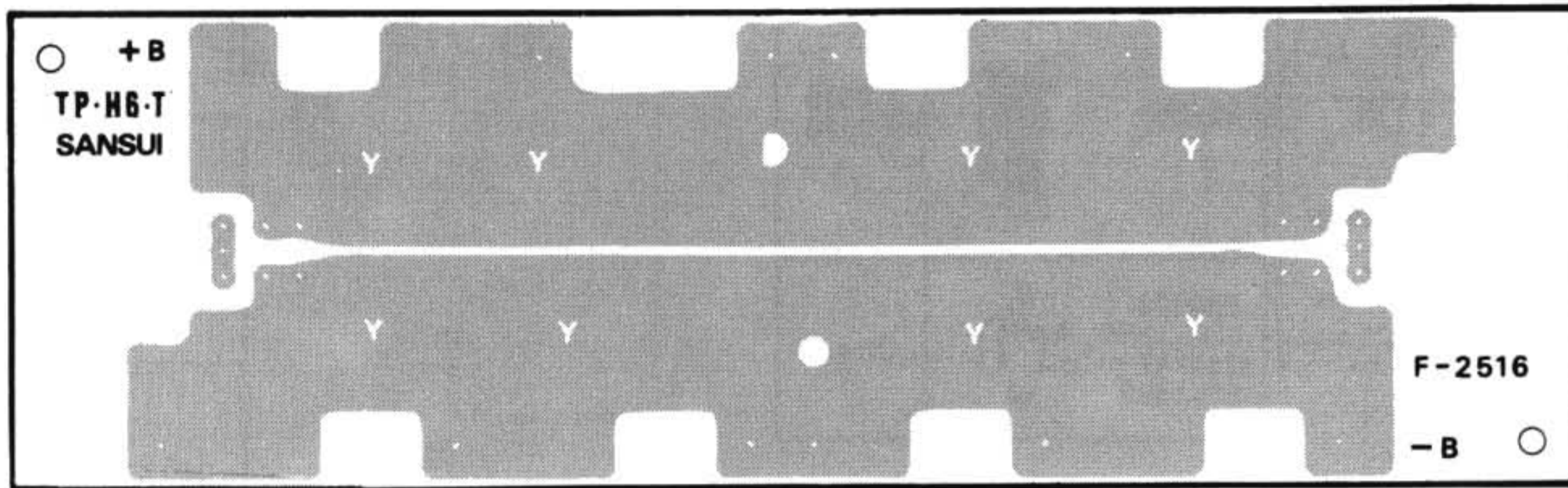

4-8. F-2506 Input Terminal Circuit Board (Stock No. 7592700 Complete Circuit Board F-2506)

Parts List

Parts No.	Stock No.	Description
	2430260	Input Terminal (White)
	2430270	Input Terminal (Red)

Conductor Side

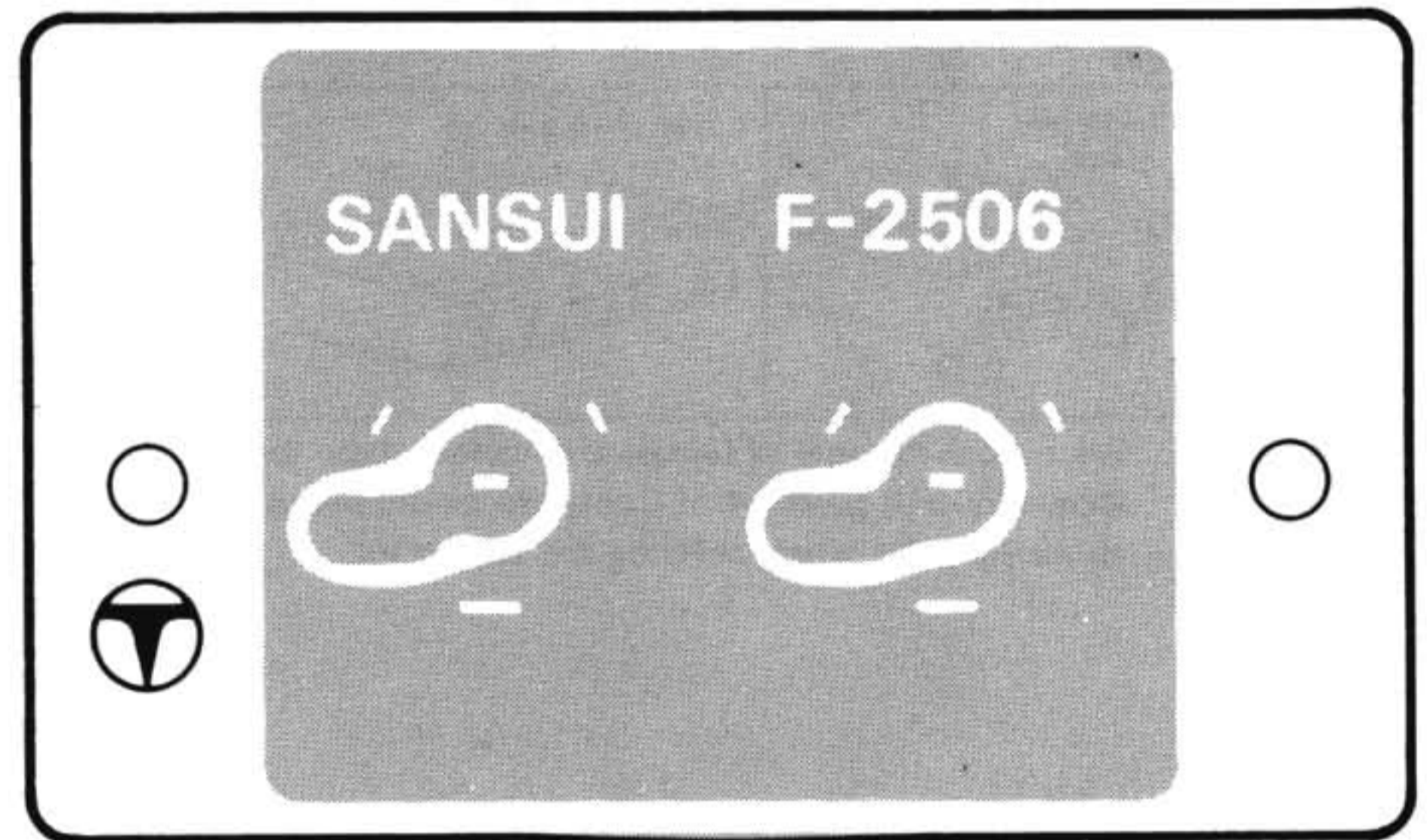



4-9. F-2514 Meter Lamp Circuit Board (Stock No. 7592710 Complete Circuit Board F-2514)

Parts List





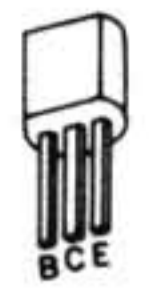
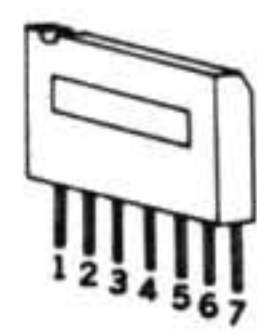
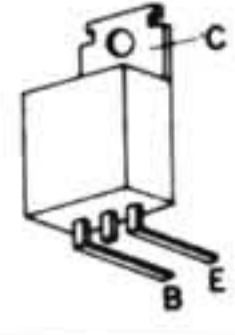
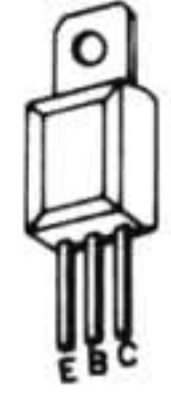

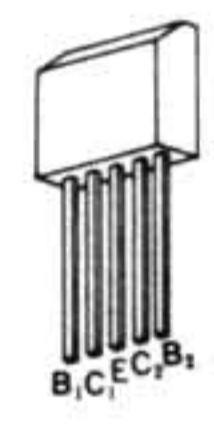
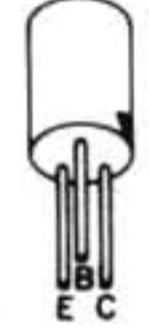
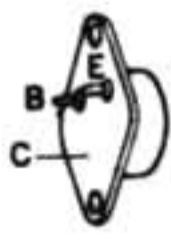
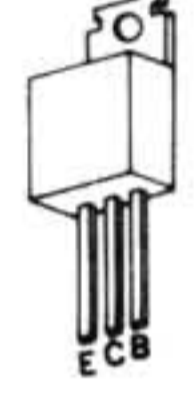
Parts No.	Stock No.	Description
PL01	0420050	7V, 300mA
PL02	0420050	7V, 300mA
PL03	0420050	7V, 300mA
	2310051	Fuse Holder

5. FIGURES, CONNECTOR & PIN Ass'y

5-1. Transistor & IC

SEMICONDUCTORS	COMPLETE CIRCUIT BOARD	SEMICONDUCTORS	COMPLETE CIRCUIT BOARD
2SA847 2SC1313 2SC1312 2SC1735 2SA850 2SC1708 	F-2521 F-2515	TA7136P 	F-2515
2SD382 	F-2521	2SC1628 2SA818 	F-2518
2SC1364 2SC945 2SA733 	F-2518 F-2520	2SA798 	F-2518 F-2520
2SC984 	F-2518	2SA908 2SC1116A 2SA747 2SC1585 	Others
2SD381 2SB536 	F-2518		

5-2. Diode

SEMICONDUCTORS	COMPLETE CIRCUIT BOARD	SEMICONDUCTORS	COMPLETE CIRCUIT BOARD
1S1850 	F-2519 F-2520	RD-24E EQB01-15 1S2473D RD-9.1E 	F-2520 F-2521 F-2518 F-2515
VD1212 	F-2515 F-2518	10D-1 	F-2520
31D27 	F-2515	SG5T 	Others

5-3. Connector & Pin Ass'y

Connector

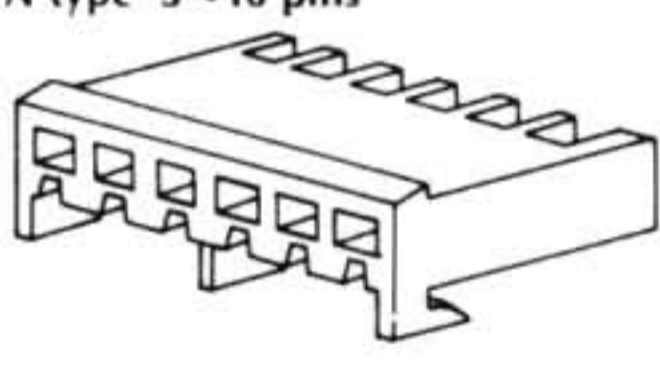
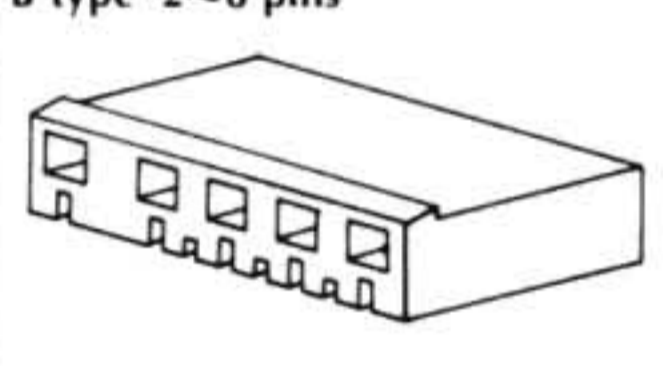
A type 3~10 pins	B type 2~6 pins	Stock No.
		2 Pins 2420250 3 Pins 2420220 4 Pins 2420230 5 Pins 2420210 6 Pins 2420240

NOTE: Since stock number of female connectors (type B) with wires are not shown in each parts list of Complete circuit board, please refer to the above parts list when ordering the connector.

Pin Ass'y

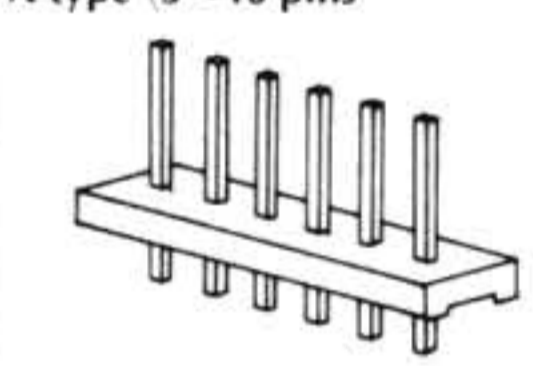
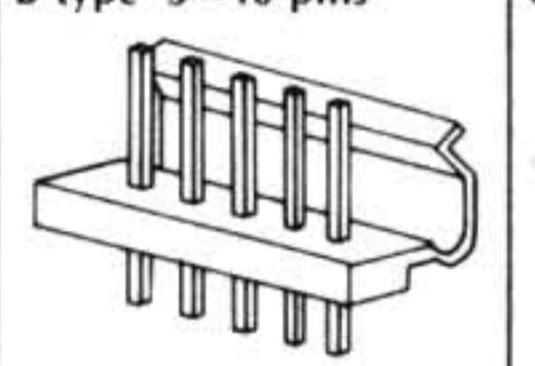
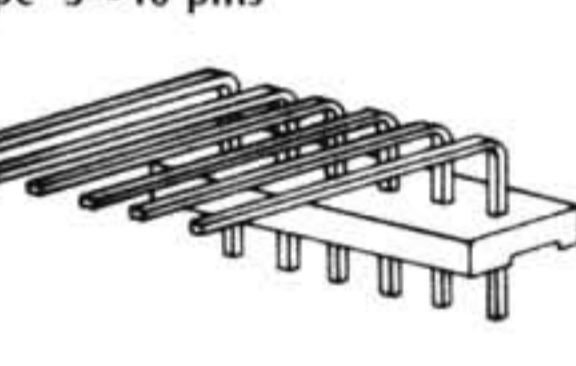
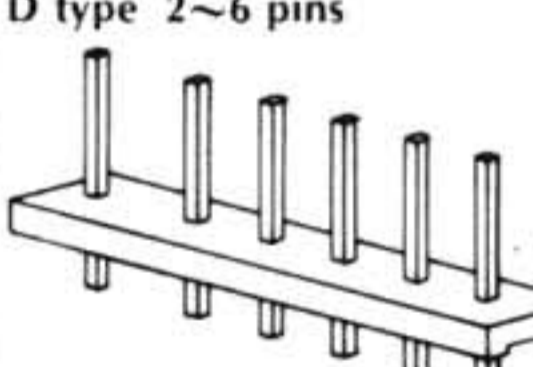
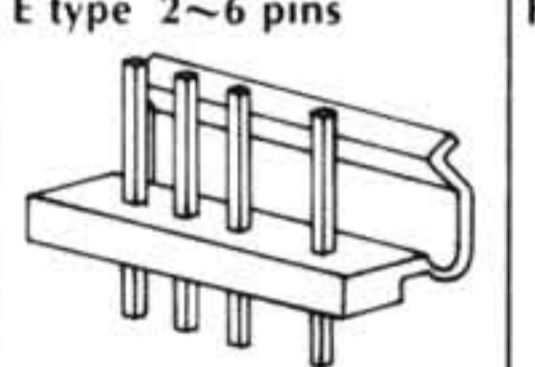
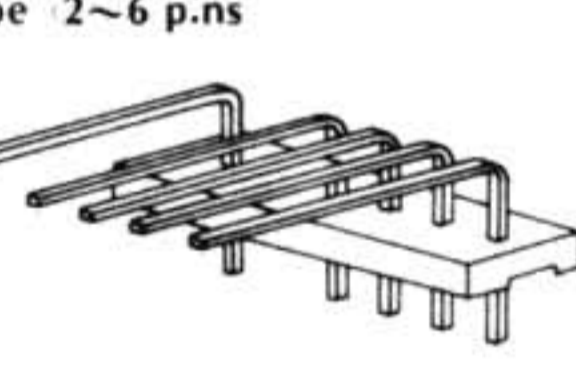
A type (3~10 pins) 	B type 3~10 pins 	C type 3~10 pins 
D type 2~6 pins 	E type 2~6 pins 	F type 2~6 pins 

6. POWER SUPPLY VOLTAGE CHANGEOVER

*In accordance with AC line voltage in your area, input AC voltages of this unit can be easily obtained by changing connections as shown in Fig. 6-1.

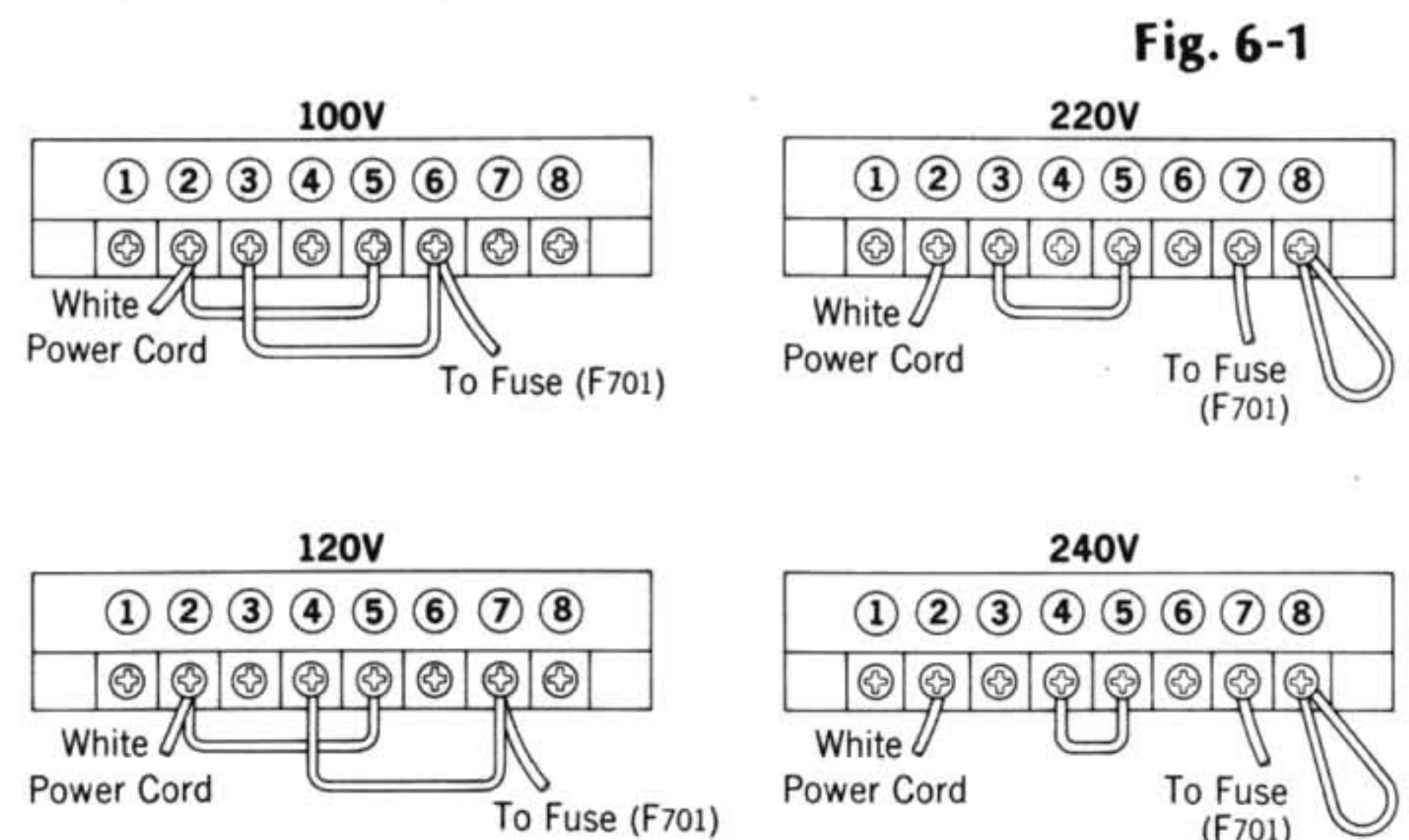

7. OTHER PARTS (Front Side)

Parts List (Front Side)

Parts No.	Stock No.	Description
1	5104044	Oval Countersunk Head Screw, M3×8
2	5123140	Corrugated Washer, 3φ
3	5186280	Plain Washer, 3φ (Fiber)
4	5026280	Side Cover (Right)
5	5026270	Side Cover (Left)
6	5058460	Front Cover
7	5058450	Rear Cover
8	5326510	E-2 Type Knob
9	5318240	A-6 Type Knob
10	5166630	Hexagon Socket Head Screw, M6×16
11	5396210	Angle
12	5286731	Lever Guide
13	7726120	Light Emitted Diode Ass'y
14	5309750	Meter Hood
15	5446220	Meter Glass
16	5336580	Badge
17	5309980	Main Panel
18	5309990	Sub Panel
19	5047460	Blind
20	5109222	Binding Head Tapping Screw, M3×8
21	4300850	Meter
22	5101149	Binding Head Screw, M3×16
23	5286690	Meter Lamp Cover
24	0420050	Fuse Type Lamp (7V, 300mA)
25	5446230	Illumination Plate
26	1171010	Lever Switch
27	1090160	100kΩ(B) Level Volume
28	5026250	Fan Cover
29	4360010	Center Fan
30	5101143	Binding Head Screw, M3×6
31	5101164	Binding Head Screw, M4×12
32	5517050	Foot
33	5058470	Bottom Plate A
34	5058480	Bottom Plate B
35	5122540	Toothed Lock Washer (External), 3φ

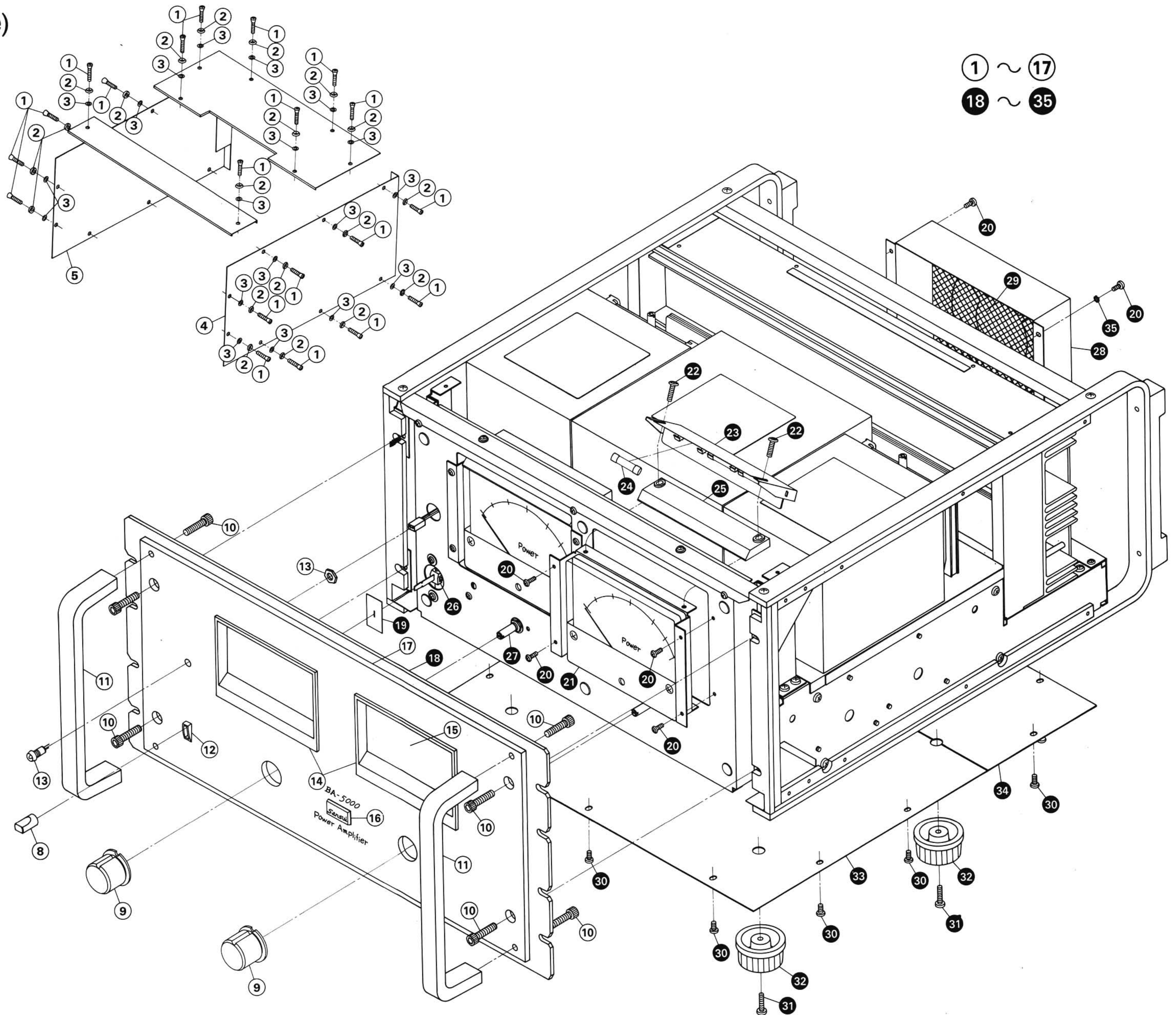

8. TROUBLESHOOTING

* The Operation of each section is outlined in the block diagram shown below. Please utilize the diagram together with "Main Troubleshooting on Each Section" in this manual, if necessary.

8-1. Operation Block Diagram

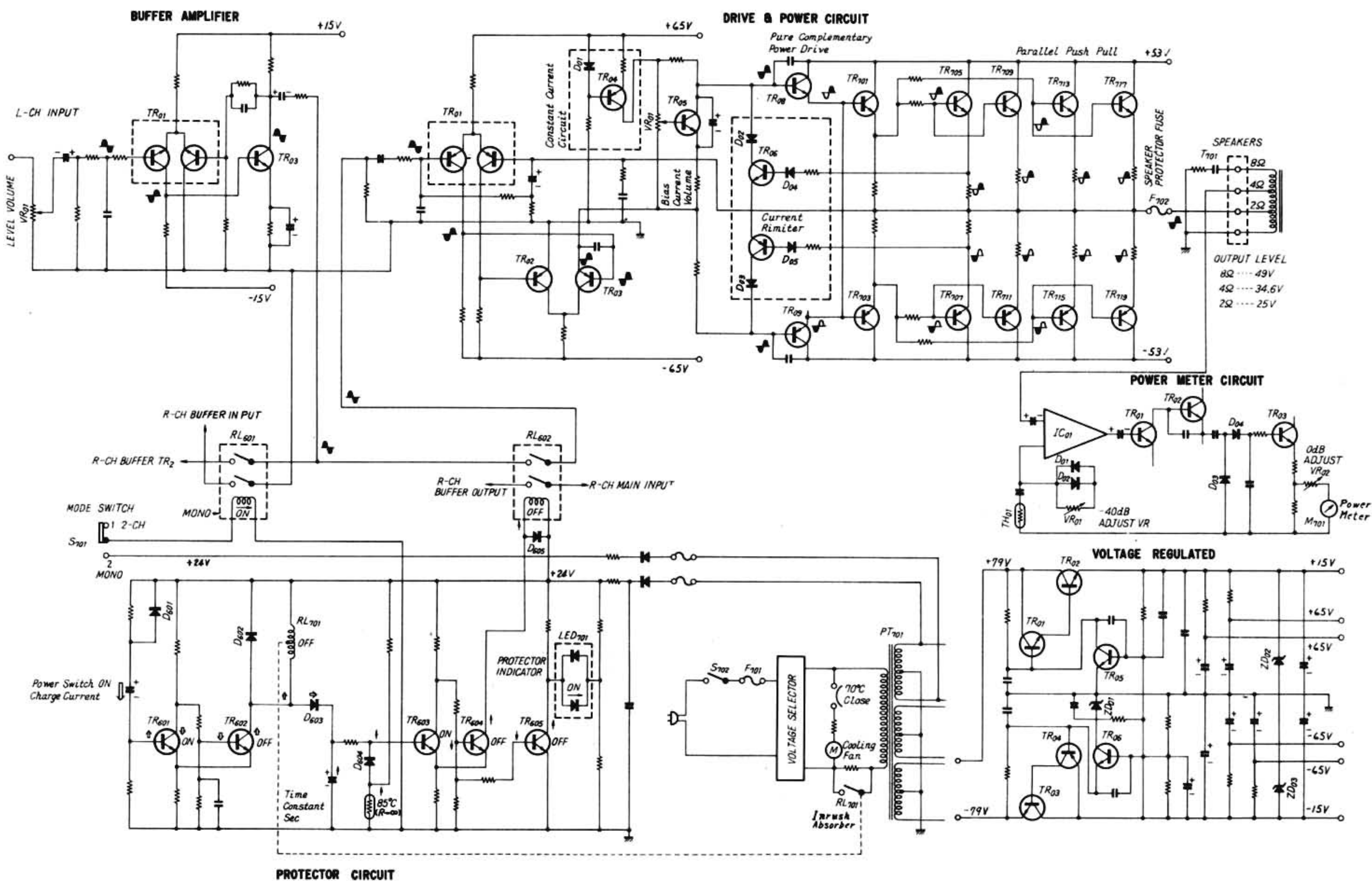

8-2. Main Troubleshooting on Each Section

1. Troubleshooting on Power Supply Section

Symptom

Cause

1-1. $\pm B$ Voltage not supplied to F-2520, F-2518, F-2516, F-2515

1) Trouble on primary of power transformer

1. Imperfect contact of power switch, S702
2. AC Fuse, F01 blows
3. R733, R734 on power supply section opens
4. Defective relay, RL701
5. Imperfect contact of voltage selector

2) $\pm 53V$ Voltage not supplied to collector on each power transistor

6. Defective Diode, D701~D704

3) $\pm 53V$ Voltage not supplied to F-2520, F-2515 and $\pm 65V$ not to F-2518

7. AC Fuse, F01, F02 blows on F-2519
8. Defective Diode, D01, D02 on F-2519
9. Defective Transistor, TR02~TR06 on F-2521
10. Defective Zener Diode, ZD01~ZD03 on F-2521

2. Troubles on Power Amp. Section

Symptom	Cause
1) Speaker Fuse, F702 (F703) blows	1. Power transistor shorted 2. Driver transistor TR701~TR704 Shorted 3. Pre Driver transistor, TR08, TR09 Shorted 4. TR05 on F-2518 opened
2) DC Bias Current not adjustable	5. Defective VR01 6. Defective Power Transistor
3) Power Amp. Inoperative (Not blowing speaker fuse)	7. $\pm B$ voltages not supplied 8. Imperfect contact of connector 9. Defective TR01, TR02, TR03

3. Troubles on Buffer Amp. Section

1) Buffer Amp. Section Inoperative	1. AC Fuse, F601 (F602) blows on F-2520 2. Defective Diode, D606 on F-2520 3. Defective Transistor, TR01~TR03
2) MONO function inoperative	4. Imperfect contact of mode switch, S701 and Defective Relay, RL601

4. Power Meter Inoperative

1. Meter position is not within 0dB \pm 1dB
2. Defective IC01 on F-2515
3. Defective Diode, D01~D04 on F-2515
4. Defective Meter

5. Protector Section Inoperative

1) Relay, RL701 Inoperative	1. Defective R733, R734 3.9k Ω (10W) 2. Defective Relay, RL701 3. Defective Transistor, TR601 (TR602) 4. Defective Capacitor, C601
2) Relay, RL602 Inoperative (Indicator lamp not lighted)	5. Defective Transistor, TR601~TR604 6. Defective Capacitor, C601 (C603) 7. Defective Diode, D603 (D604) 8. Defective Relay, RL602

9. OTHER PARTS (Top, Bottom Side)

Top Side

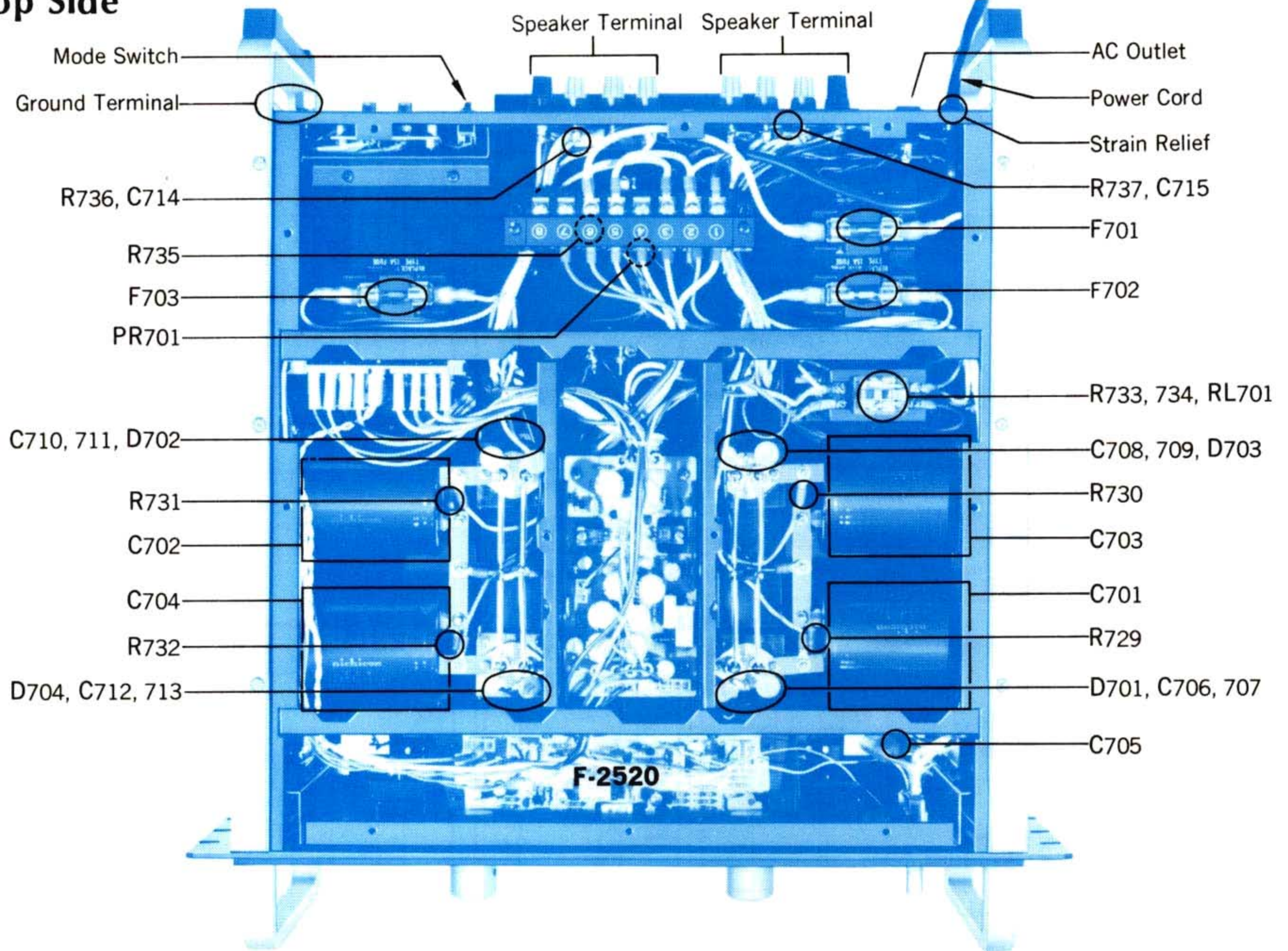

Bottom Side

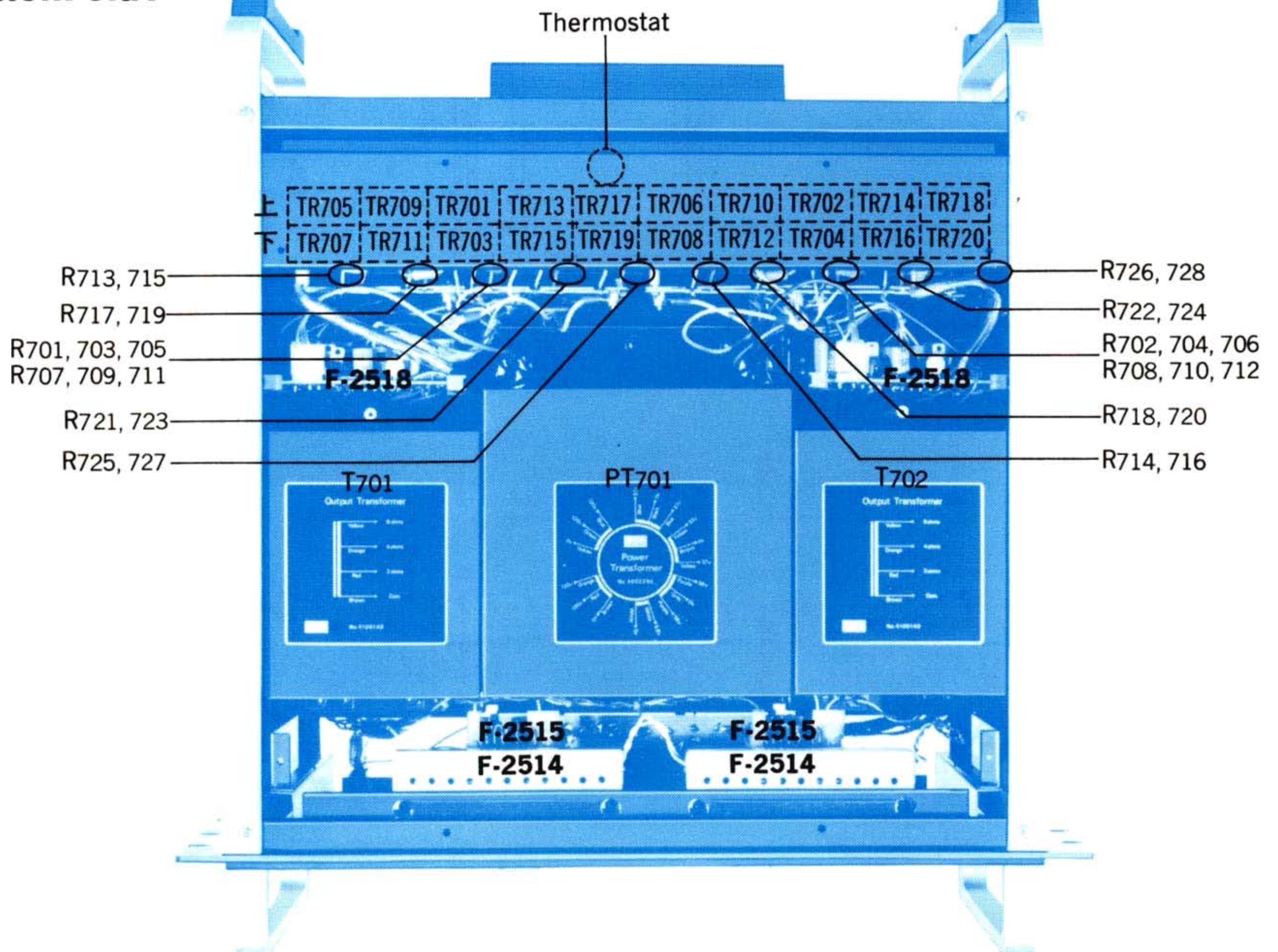

Parts List (Top, Bottom Side)

Parts No.	Stock No.	Description
TR701, 702	0306331	2SC1116A (O)
	or	or
TR703, 704	0306332	2SC1116A (Y)
	or	or
TR705, 706	0300751	2SA747A (O)
	or	or
TR707, 708	0300752	2SA747A (Y)
	or	or
TR709, 710	0306310	2SC1585 (O)
	or	or
TR711, 712	0306311	2SC1585 (Y)
	or	or
TR713, 714	0300730	2SA908 (R)
	or	or
TR715, 716	0300731	2SA908 (O)
	or	or
TR717, 718	0306310	2SC1585 (O)
	or	or
TR719, 720	0306311	2SC1585 (Y)
	or	or
D701	0311440	SG-5TS
	0311440	SG-5TR
LD701	7726120	Light Emitted Diode Ass'y
PR701	0320120	PTH487A 01BE 302TS Thermistor
C701 - C715	0559512	22000 μ F
	0559512	22000 μ F
	0559512	22000 μ F
	0559512	22000 μ F
	0605477	0.047 μ F 250V
	0659011	10000 pF
	0659011	10000 pF
	0659011	10000 pF
	0659011	10000 pF
	0659011	10000 pF
	0659011	10000 pF
	0659011	10000 pF
	0601108	0.1 μ F
	0601108	0.1 μ F
	R701 - R712	0152100
0152100		10 Ω
0152100		10 Ω
0152100		10 Ω
0104479		4.7 Ω
0104449		4.7 Ω
0104479		4.7 Ω
0104479		4.7 Ω
0104479		4.7 Ω
0104479		4.7 Ω
0104479		4.7 Ω
0104479		4.7 Ω

Transistor

Diode

500V C.C.

50V M.C.

2 W Ce.R.

1 W Ce.R.

1 W Ce.R.

Parts No.	Stock No.	Description
R713	0155338	0.33 Ω
R714	0155338	0.33 Ω
R715	0155338	0.33 Ω
R716	0155338	0.33 Ω
R717	0155338	0.33 Ω
R718	0155338	0.33 Ω
R719	0155338	0.33 Ω
R720	0155338	0.33 Ω
R721	0155338	0.33 Ω
R722	0155338	0.33 Ω
R723	0155338	0.33 Ω
R724	0155338	0.33 Ω
R725	0155338	0.33 Ω
R726	0155338	0.33 Ω
R727	0155338	0.33 Ω
R728	0155338	0.33 Ω
R729	0104472	4.7k Ω
R730	0104472	4.7k Ω
R731	0104472	4.7k Ω
R732	0104472	4.7k Ω
R733	0159080	3.9 Ω
R734	0159080	3.9 Ω
R735	0153121	120 Ω
R736	0155479	4.7 Ω
R737	0155479	4.7 Ω
T701	4100140	T-8537
T702	4100140	T-8537
PT701	4002260	Power Transformer
RL701	1150350	LY2-SA Relay
S701	1110300	SSB02225 Slide Switch
S702	1171010	Lever Switch
F701	0434040	15A 250V
F702	0433040	15A 250V
F703	0433040	15A 250V
	1910010	Thermostat
	2210290	Speaker Terminal
	2230051	Ground Terminal
	2310200	Fuse Holder
	2450060	AC Outlet
	3800280	Power Cord
	3910570	Strain Relief

5 W Ce.R.

1 W C.R.

10W Ce.R.

3 W Ce.R.

5 W Ce.R.

Outout Transformer

Power Transformer

* When replacing Transistor in column A, use one in column B certainly. Letter (O, R or Y) is shown on the head of Transistor (See Fig. 9-1).

Fig. 9-1



check letter **O**, **R** or **Y**

Parts No.	A	Mark	Parts No.	B	Mark
TR701	2SC1116A	O	TR701	2SC1116A	O
TR701	2SC1116A	Y	TR701	2SC1116A	Y
TR703	2SA747A	O	TR703	2SA747A	O
TR703	2SA747A	Y	TR703	2SA747A	Y
TR705, TR709 TR713, TR717	2SC1585	O	TR705, TR709 TR713, TR717	2SC1585	O
TR705, TR709 TR713, TR717	2SC1585	Y	TR705, TR709 TR713, TR717	2SC1585	Y
TR707, TR711 TR715, TR719	2SA908	O	TR707, TR711 TR715, TR719	2SA908	O
TR707, TR711 TR715, TR719	2SA908	R	TR707, TR711 TR715, TR719	2SA908	R

10. SCHEMATIC DIAGRAM

* La présentation et les spécifications sont susceptibles d'être modifiées sans préavis par suite d'améliorations éventuelles.
 * Änderung, die dem technischen Fortschritt dienen, bleiben vorbehalten.
 * Design and specifications subject to change without notice for improvements.



11. PACKING LIST

Parts No.	Stock No.	Description
1	9017740	Packing (Top)
2	9017750	Packing (Bottom)
	9116660	Vinyl Cover
3	9017730	Corner Packing
4	9008330	Carton Case
	5996080	Curl Stopper

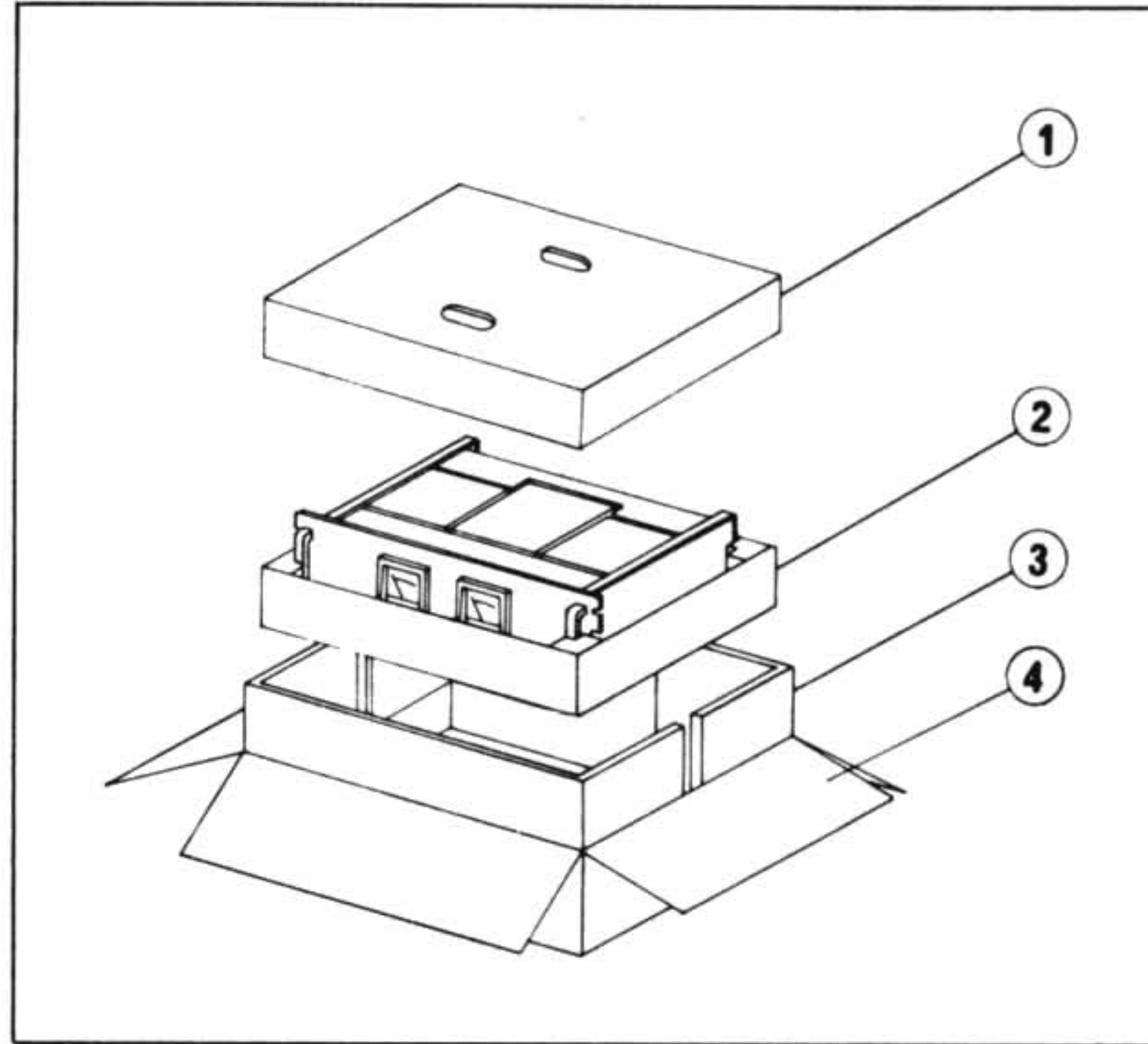

12. ACCESSORY PARTS LIST

Stock No.	Description
9208940	Operating Instructions
9236990	Schematic Diagram

The Sansui logo consists of the word "Sansui" in a white, italicized serif font, set against a solid black rectangular background.

SANSUI ELECTRIC CO., LTD.
14-1, 2-chome, Izumi, Suginamiku, Tokyo 168, Japan.
TELEPHONE: (03) 323-1111 / TELEX: 232-2076

SM041

Printed in Japan (O5025M)