

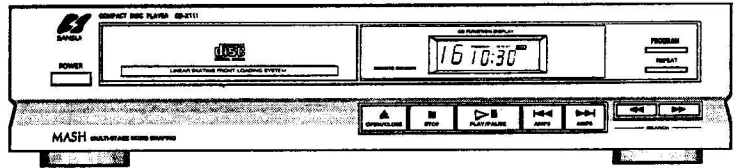

SERVICE MANUAL

CD-X111 CD-2700 COMPACT DISC PLAYER



CAUTION

1. Parts identified by the Δ symbol on the schematic diagram and the parts list are critical for safety. Use only replacement parts that have critical characteristics recommended by the manufacturer.
2. Make leakage-current or resistance measurements to determine that exposed parts are acceptably insulated from the supply circuit before returning the appliance to the customer.

NOTICE

1. Some printed circuit board are not supplied assembled. To separate these in this service manual, the stock numbers are not indicated for these boards. However, stock numbers for individual parts are indicated.
2. The symbols, UL, CSA, EU, SEV, SS and XX <EXPORT> on the Parts List and the schematic diagram mean followings respectively.
 - UL Manufactured for U.S.A. market.
(Underwriters Laboratories approved model.)
 - CSA Manufactured for Canadian market.
 - EU Manufactured for European market.
 - EG Manufactured for F. R. Germany market.
 - UK Manufactured for United Kingdom market.
 - SEV Manufactured for Swiss market.
 - SS Manufactured for Saudi Arabia market.
 - XX Standard Version.
 - <EXPORT>
NON MARK Common Parts.
3. Since some capacitors and resistors are omitted from parts lists in this Parts List, refer to the Common Parts List for capacitors and resistors, which was issued on June 1987.
4. Abbreviations in this Parts List are as follows.

•Abbreviations List

C.R.	: Carbon Resistor	E.B.L.	: Low Leak Bi-Polar Electrolytic Capacitor
S.R.	: Solid Resistor	Ta.C.	: Tantalum Capacitor
Ce.R.	: Cement Resistor	F.C.	: Film Capacitor
M.R.	: Metal Film Resistor	M.P.	: Metalized Paper Capacitor
F.R.	: Fusing Resistor	P.C.	: Polystyrene Capacitor
N.I.R.	: Non-Inflammable Resistor	M.M.C.	: Metalized Mylar Capacitor
A.R.	: Array Resistor	A.C.	: Array Capacitor
C.C.	: Ceramic Capacitor	V.R.	: Variable Resistor
C.T.	: Ceramic Capacitor, Temperature Compensation	S.V.R.	: Semi Variable Resistor
E.C.	: Electrolytic Capacitor	SW.	: Switch
E.L.	: Low Leak Electrolytic Capacitor	Chip R.	: Chip Resistor
E.B.	: Bi-Polar Electrolytic Capacitor	Chip C.	: Chip Capacitor

Specifications

Format.....	Compact disc, digital audio system
Pickup.....	3-Beam, semiconductor laser
Decoding (D/A).....	1-Bit 4-DAC / MASH (MASH is trademark of NTT)
Frequency response.....	20 Hz to 20 kHz, ± 0.5 dB
Total harmonic distortion.....	Less than 0.005% (1 kHz)
Signal-to-Noise ratio.....	Better than 100 dB
Dynamic range.....	Better than 96 dB
Wow & flutter.....	Below measurable limit
Output voltages/load impedances.....	2 V / 47 kohms or more

Power consumption.....	AC 120, 220~240 V (50/60 Hz) For U.S.A & Canada.....AC 120 V, 60 Hz
Rated power consumption.....	13 W
Dimensions.....	430 mm (16-15/16") W 93.5 mm (3-11/16") H 286 mm (11-5/16") D
Weight.....	3.3 kg (7.3 lbs) net

- * Design and specifications subject to changes without notice for improvements.
- * Due to local laws and regulations, this unit sold in some areas are not equipped with variable voltage selectors.

Cautions Concerning Handling of The Laser

CAUTION: USE OF CONTROLS FOR ADJUSTMENTS OR PERFORMANCE OF PROCEDURES OTHER THAN THOSE SPECIFIED HEREIN MAY RESULT IN HAZARDOUS RADIATION EXPOSURE. THE COMPACT DISC PLAYER SHOULD NOT BE ADJUSTED OR REPAIRED BY ANYONE EXCEPT PROPERLY QUALIFIED SERVICE PERSONNEL.

* The following label has been affixed to the unit, listing the proper procedure for working with the laser beam.

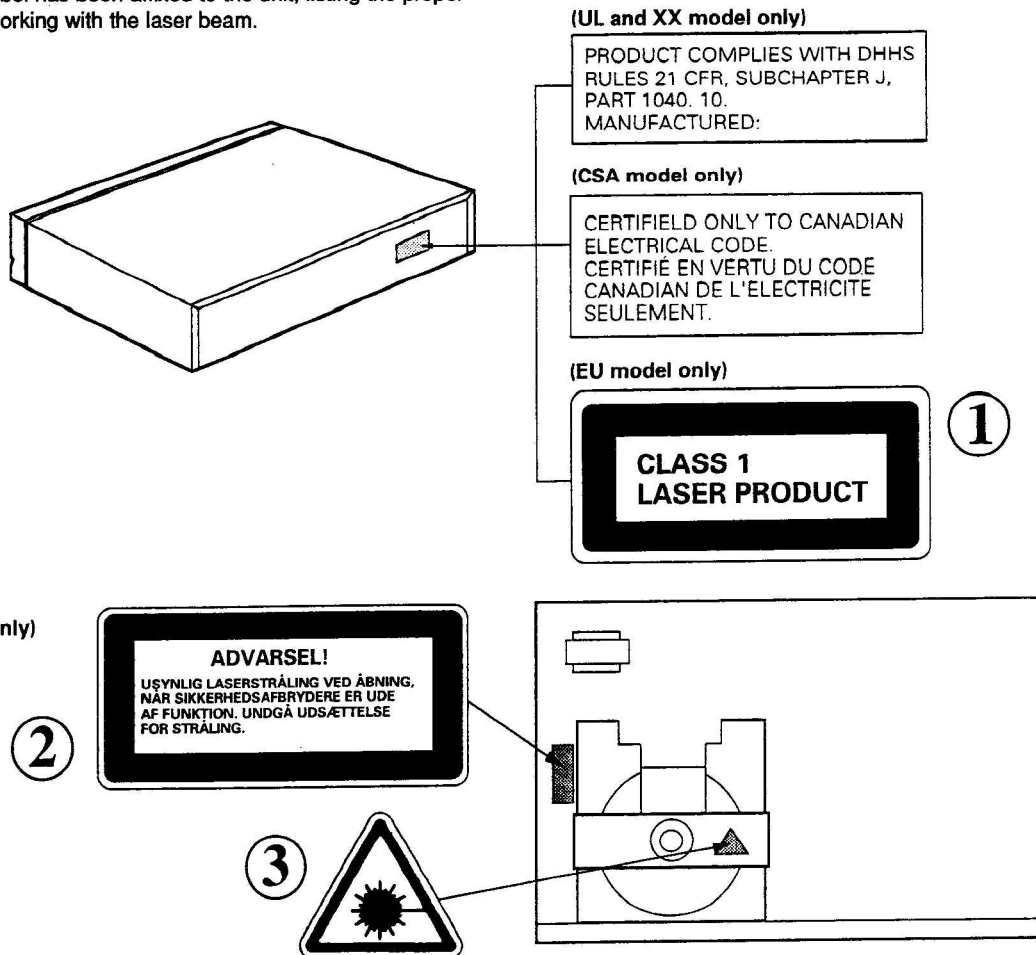

1. PACKING & ACCESSORY LIST

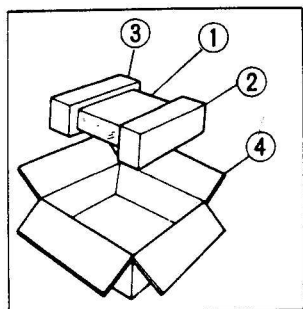

<Parts List>

Parts No.	Stock No.	Description
1	9905406640	Vinyl Bag <CD-X111>
	9905405340	Vinyl Bag <CD-2700>
2	JS80017340	Styrofoam Packing, right
3	JS80017340	Styrofoam Packing, left
4	JS85025000	Carton Case <CD-X111>
	JS85025200	Carton Case <CD-2700>

<Accessory Parts>

Parts No.	Stock No.	Description
	9080017330	Operating Instructions <CD-X111>
	9080017340	Operating Instructions <CD-2700>
	5620709501	Pin Plug Cord
	71584020S1	Remote Controller Ass'y, RS-1210

2. BLOCK DIAGRAM

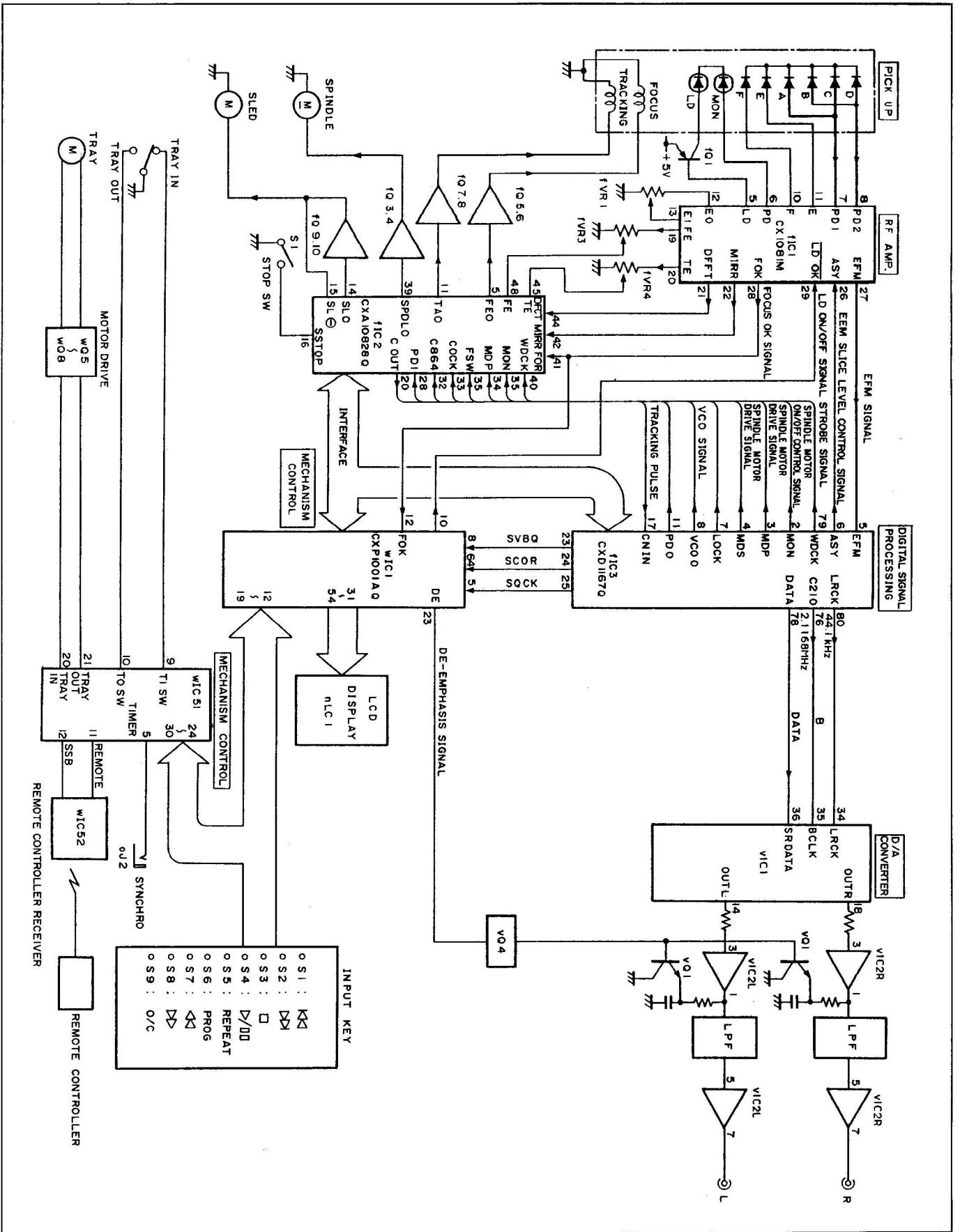

3. ADJUSTMENT

• Cautions

1. Turn the power OFF before removing the bonnet.
2. See Figure 3-1 for the locations where adjustments are to be carried out.
3. Use the EIAJ test disk CD-1.
4. The following band pass filter (BPF) is used for adjustments.
5. If the adjustment is unsatisfactory and playback is not possible, adjust as follows:
 - 1) Set fVR1, fVR2, fVR3 and fVR4 to their mid points.
 - 2) Adjust the VCO (fVR5) and select playback.
 - 3) Carry out adjustment steps 2 to 5.
6. In executing steps 2 to 5, connect the probe after playing the disc.

Band Pass Filter (BPF)

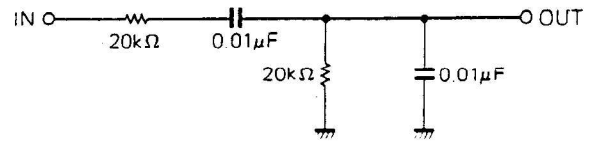

Step	Item	Measuring Location	Adjustment Location	Adjustment	Conditions and Notes
1	VCO adjustment (carry out in STOP state)	Connect a frequency counter to TP4 (CLK).	fVR5 (VCO)	4.32MHz ± 30kHz	<ul style="list-style-type: none"> • Ground EFM (TP3 of F-6521). • Turn ON the power then wait at least 10 seconds before adjusting.
2	Tracking offset adjustment	Connect an oscilloscope to T1 of TP2.	fVR1	<p>Set the oscilloscope to the DC range. Adjust so that a and b have the same level.</p>	<ul style="list-style-type: none"> • Ground T2 of TP2. • Playback the 8th track of CD-1.
3	Focus offset	Connect an oscilloscope to the RF of TP1.	fVR2	<p>Set to maximum.</p> <p>Carry out adjustments to achieve a clean overall pattern and so that the indicated portion is wide and symmetrical.</p>	<ul style="list-style-type: none"> • Playback the 8th track of CD-1.
4	Tracking gain adjustment	Connect AC voltmeter to T1 of TP2 via the BPF. Connect AC voltmeter to T2 of TP2 via the BPF.	fVR4	<p>Using the indicated voltage at T1 of TP2 as a reference, adjust the voltage at T2 to -3.5dB.</p>	<ul style="list-style-type: none"> • Playback the 4th track (no signal) of CD-1. • Apply an 800Hz signal of 0.5Vp-p from SG to T2 of TP2 via a resistance of 220kΩ. <p>Adjust fVR4 to the position shown in the figure. If you do not have a BPF or if -3.5dB cannot be achieved.</p>

Step	Item	Measuring Location	Adjustment Location	Adjustment	Conditions and Notes
5	Focus gain adjustment	Connect AC voltmeter to F1 of TP2 via the BPF. Connect AC voltmeter to F2 of TP2 via the BPF.	fVR3	 <p>Using the indicated voltage at F1 of TP2 as a reference, adjust the voltage at F2 to -2.5dB.</p>	 <ul style="list-style-type: none"> • Playback the 4th track (no signal) of CD-1. • Apply an 800Hz signal of 0.5Vp-p from SG to F2 of TP2 via a resistance of 220kΩ.  <p>Adjust fVR4 to position shown in the Figure if you do not have a BPF or if -2.5dB cannot be achieved.</p>

Fig. 3-1



4. INTERIOR BLOCK DIAGRAM & TERMINAL FUNCTION OF LCD & ICs

• HLC9538-01-2111 <LCD Display>

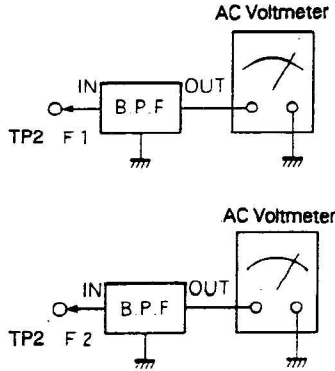
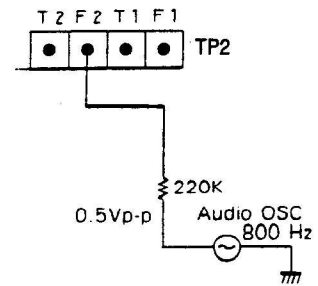
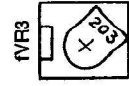
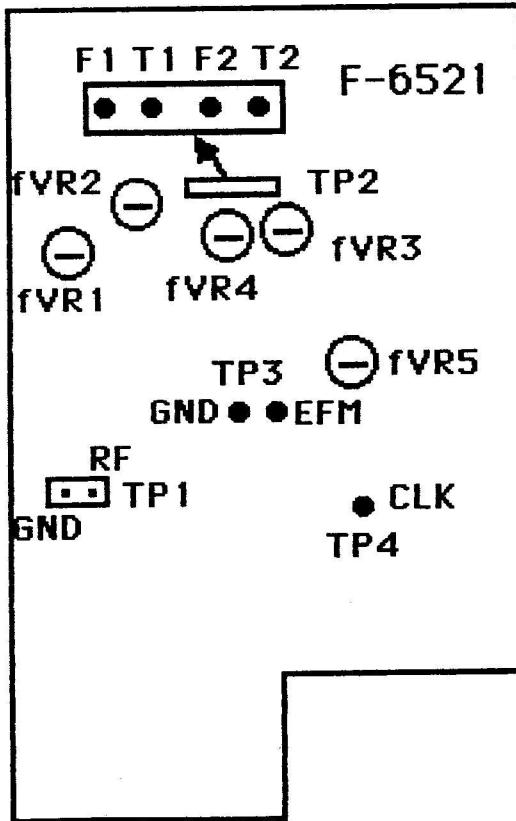
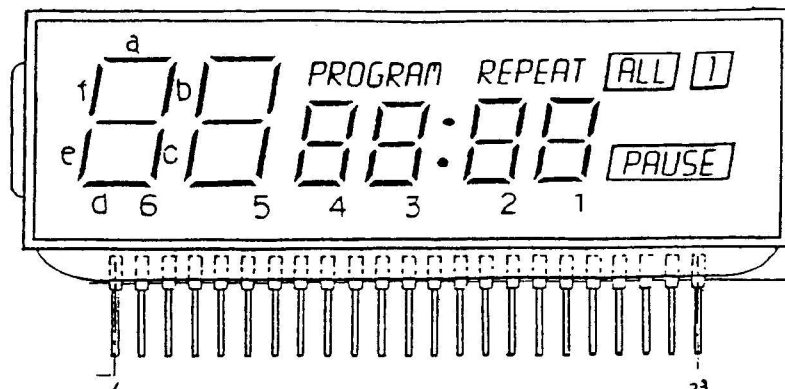

No.	COM. 1	COM. 2	COM. 3
1	COM. 1		
2		COM. 2	
3			COM. 3
4	REPEAT	1	ALL
5	PAUSE		
6		6-e	6-f
7	6-d	6-g	6-a
8	PROGRAM	6-c	6-b
9		5-e	5-f
10	5-d	5-g	5-a
11		5-c	5-b
12		4-e	4-f

No.	COM. 1	COM. 2	COM. 3
13	4-d	4-g	4-a
14		4-c	4-b
15		3-e	3-f
16	3-d	3-g	3-a
17	:	3-c	3-b
18		2-e	2-f
19	2-d	2-g	2-a
20		2-c	2-b
21		1-e	1-f
22	1-d	1-g	1-a
23		1-c	1-b

• LC6543C <Remote Control Decoder>

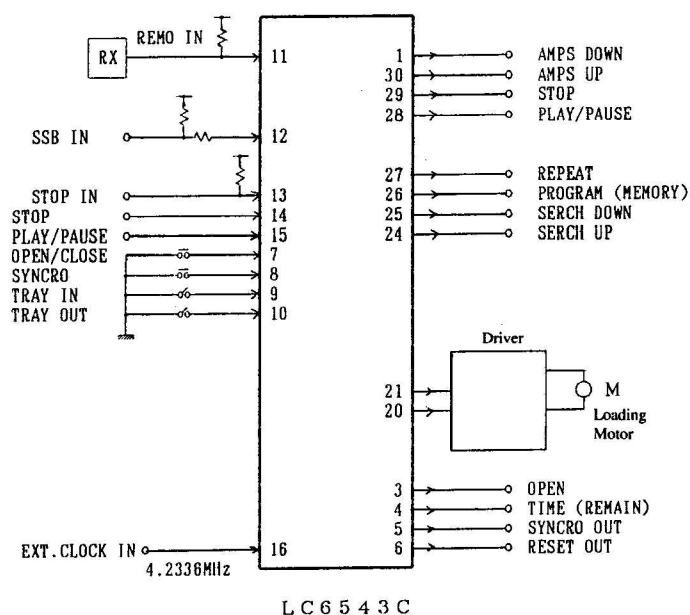

◆ Terminal Function

Port	I/O	Pin No.	Function	Active H	L
PA 0	in	11	REMCON Input		○
1	in	12	SSB Input		○
2	in	13	STOP Input (Check for Spindle Stop)	○	
3	in	14	STOP KEY Input		○
PC 0	out	20	For Driver Output Loading	○	
1	out	21	For Driver Output Unloading	○	
2	out	22			
3	out	23			
PD 0	out	24	SERCH UP for KEY output		○
1	out	25	SERCH DOWN for KEY output		○
2	out	26	PROGRAM for KEY output		○
3	out	27	REPEAT for KEY output		○
PE 0	out	28	PLAY/PAUSE for KEY output		○
1	out	29	STOP for KEY output		○
2	out	30	AMPS UP for KEY output		○
3	out	1	AMPS DOWN for KEY output		○
PF 0	out	3	For OPEN (Disk in="H") Terminal output	○	
1	out	4	TIME for KEY output		○
2	out	5	SYNCRO output		○
3	out	6	RESET output 10 msec		○
PG 0	in	7	OPEN/CLOSE KEY Input		○
1	in	8	SYNCRO KEY Input		○
2	in	9	TRAY IN SW Input (ON = "L")		○
3	in	10	TRAY OUT SW Input (ON = "L")		○
PI 0	in	15	From PLAY/PAUSE KEY		○
OSC	in	16	EXT. CLOCK Input 4.2336 MHz		

* For KEY output 100 msec
 Chartering KEY Input 20~30 msec
 SW Input 1~2 msec

• CXA1082BQ <Focus/Tracking Servo>

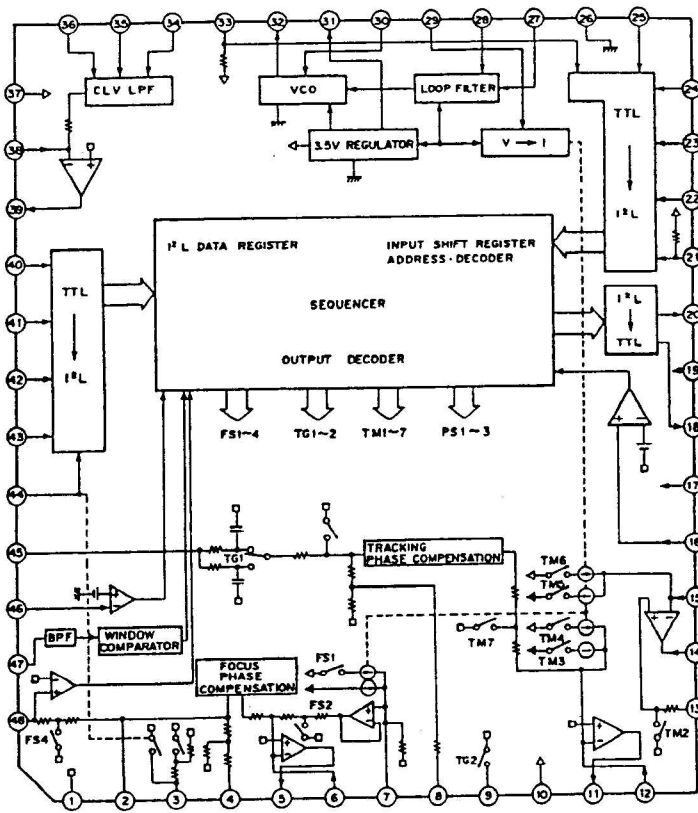

◆ Terminal Function <CXA1082BQ>

Pin No.	Pin Name	I/O	Description
2	FGD	I	A capacitor is connected between this Pin and F3 (Pin 3) for decreasing high-frequency gain of focus servo.
3	FS3	O	Terminal for switching high-frequency gain of focus servo.
4	FLB	—	This Pin is used to connect a time constant for increasing low-frequency characteristic of focus servo.
5	FEO	O	Terminal for outputting a signal for driving focus coil.
11	TAO	O	Terminal for outputting a signal for driving tracking coil.
14	SLD	O	Terminal for outputting a drive signal for sled motor.
39	SPDLO	O	Terminal for outputting a drive signal for spindle (disc) motor.
6	FE ⊖	I	Focus amplifier inverting input.
7	SRCH	I	This terminal is used to determine time constant for generating focus search waveform.
8	TGU TG2		Terminals are used to determine a time constant for switching tracking high-frequency gain.
12	TA ⊖	I	Tracking amplifier inverting input.
13	SL ⊕	I	Sled (Feed) amplifier non-inverting input.
15	SL ⊖	I	Sled amplifier inverting input.
16	SSTOP	I	Terminal for inputting a signal from limit switch ON/OFF for detecting innermost track of disc.
17	FSET	I	Terminal for setting focus and tracking phase-compensation peaks and fo of CLV LPF.
18	SENS	O	Terminal for outputting internal condition data.
20	C.OUT	O	Terminal for outputting a signal for counting track number of disc.
21	DIRC		This terminal is used for one-track jump operation.

<CXA1082BQ>

Pin No.	Pin Name	I/O	Description
22	XRST		Terminal for inputting a reset signal. Reset operation in "L" level.
23	DATA	I	Serial data input from the CXP1001AQ mechanism control.
24	XLT	I	Terminal for inputting a latch signal for serial data from the CXP1001AQ mechanism control.
25	CLK	I	Serial data clock input from the CXP1001AQ mechanism control.
26	DGND	—	Ground.
28	PDI	I	PDO signal input from the phase comparator of the CXD1167Q digital signal processing.
29	ISCT	O	Terminal for outputting a current to determine focus search, track jump and siding kick height.
30	VCOF	I	VCO free-frequency is practically proportional to resistance between this Pin and Pin 31.
32	C864	O	Internal 8.64 MHz VCO output.
34	MDP	I	A spindle motor driving signal input from the CXD1125 digital signal processing (MDP terminal).
35	MON	I	A spindle motor ON/OFF signal input from the CXD1125 digital signal processing (MON terminal).
36	FSW	—	This terminal is used to determine a time constant for LPF of CLV servo error signal.
38	SPDL ⊖	I	Spindle drive amplifier inverting input.
40	WDCK	I	Auto sequence clock input. Typical frequency = 88.2 kHz.
41	FOK	I	FOK signal input from the CXA1081S.
42	MIRR	I	Mirror comparator signal input from the CXA1081S.
44	DFCT	I	Defect comparator signal input from the CXA1081S.
45	TE	I	Tracking error amplifier signal input from CXA1081S.
46	TZC	I	Tracking zero cross comparator signal input.
47	ATSC	I	Window comparator input for ATSC detection.
48	FE	I	Focus error amplifier signal input.

CXD1167Q (Digital Signal Processing)

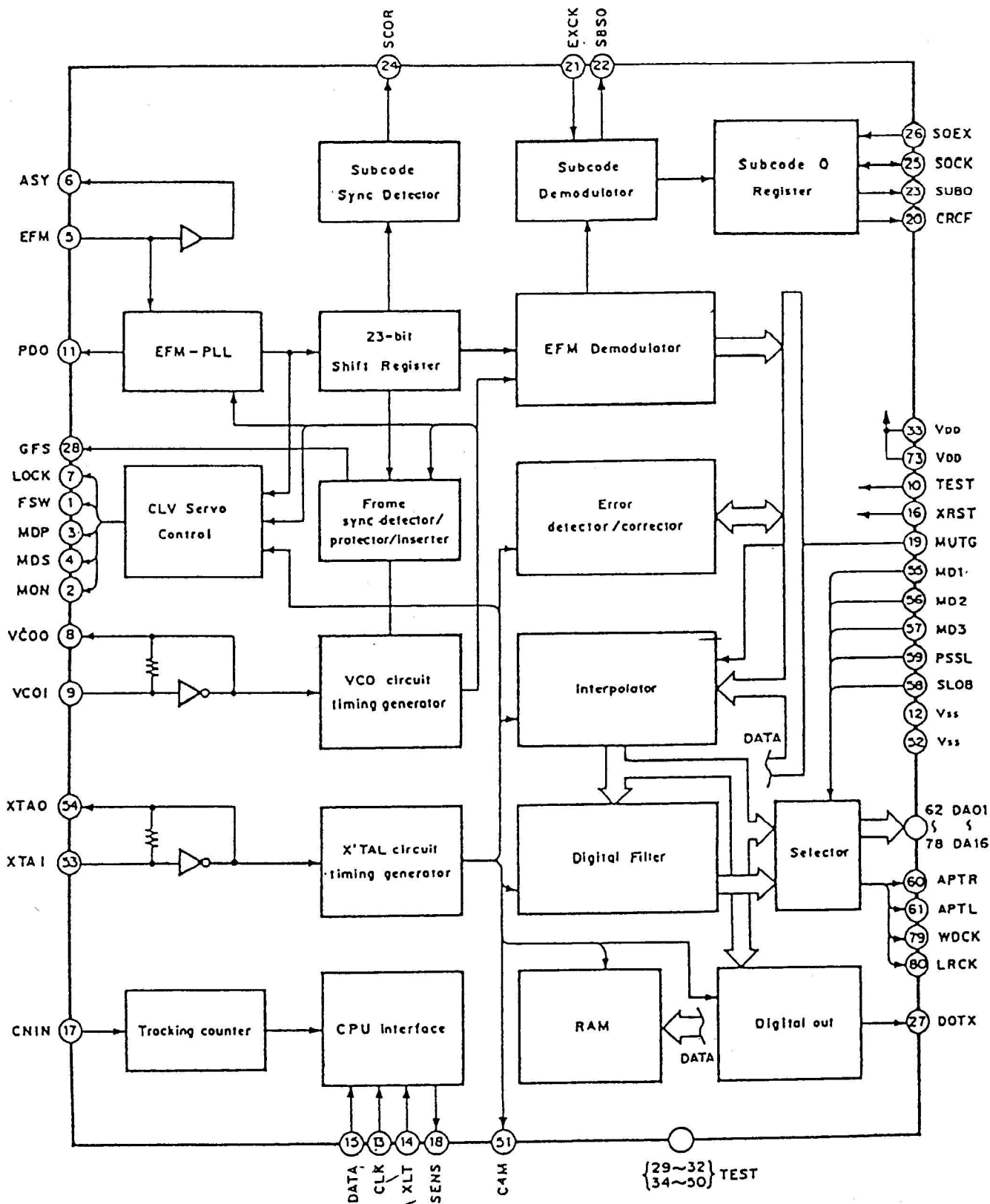

Terminal Function <CXD1167Q>

Pin No.	Pin Name	I/O	Function
1	FSW	O	Output to change the time constant of the output filter for the spindle motor
2	MON	O	Output to control ON/OFF of the spindle motor
3	MDP	O	Output to drive the spindle motor. For rough control in the CLV-S mode and phase control in the CLV-P mode.
4	MDS	O	Output to drive the spindle motor. For speed control in the CLV-P mode.
5	EFM	I	EFM signal input from the RF amplifier
6	ASY	O	Output to control the slice level of the EFM signal.
7	LOCK	O	Issues "H" when the GFS signal is "H" by sampling with WFCK/16. If it is "L" consecutively 8 times, "L" is output.
8	VCOO	O	VCO output. $f = 8.6436$ MHz when locked to the EFM signal. (17.2872 MHz when replayed at the double speed.)
9	VCOI	I	VCO input
10	TEST	I	(0V)
11	PDO	O	Output of phase comparison between the EFM signal and VCO/2
12	Vss	—	GND (0V)
13	CLK	I	Input of clock from CPU to transfer serial data. Data is latched at the rise edge of the clock.
14	XLT	I	Latch input from CPU. The data (serial data from CPU) of the 8 bit shift register is latched to each register.
15	DATA	I	Serial data input from CPU
16	XRST	I	System reset input. "L" activates resetting.
17	CNIN	I	Input of tracking pulse
18	SENS	O	Issues internal status according to the address
19	MUTG	I	Muting input. When ATTM of the internal register A is "L", MUTG is "L", i.e. normal status. "H" activates no-sound status.
20	CRCF	O	Issues the output of CRC check result for the subcode Q.
21	EXCK	I	Clock input for serial output of subcode
22	SBSO	O	Serial output of subcode
23	SUBQ	O	Output of subcode Q
24	SCOR	O	Output of subcode sync S0 + S1
25	SQCK	I/O	Clock to read subcode Q.
26	SQEX	I	SQCK selection input (see the CPU interface for more detail.)
27	DOTX	O	Digital output (WFCK is output when DO is OFF.)
28	GFS	O	Output to indicate locked status of frame sync
29~33	TEST	I	Fix to "H" or "L". Don't make it open.
33	Vdd	—	Power supply (+ 5V)
34~40	TEST	I	Fix to "H" or "L". Don't make it open.
41~50	TEST	I	Fix to "H" or "L". Don't make it open.
51	C4M	O	Frequency division output of the crystal oscillator. $f = 4.2336$ MHz (8.4672 MHz when replayed at the double speed.)
52	Vss	—	GND (0V)
53	XTAI	I	Input to the crystal oscillator circuit. $f = 8.4672$ MHz or 16.9344 MHz by selecting mode. (16.9344 MHz when replaying at the double speed.)

Pin No.	Pin Name	I/O	Function
54	XTAO	O	Output to the crystal oscillator circuit. $f = 8.4672$ MHz or 16.9344 MHz by selecting mode. (16.9344 MHz when replaying at the double speed.)
55	MD1	I	Mode select input 1
56	MD2	I	Mode select input 2
57	MD3	I	Mode select input 3
58	SLOB	I	Input to change the code of audio data output. When it is "L" or "H", 2's compliment output or offset binary output is issued, respectively.
59	PSSL	I	Input to change the mode of audio data output. When it is "L" or "H", serial or parallel output is issued, respectively.
60	APTR	O	Control output to correct aperture. "H" for R-ch.
61	APTL	O	Control output to correct aperture. "H" for L-ch
62	DA01	O	When PSSL = "H", DA01 (LSB of parallel sound data) is output. When PSSL = "L", C1F1 is output.
63	DA02	O	When PSSL = "H" or "L", DA02 or C1F2 is output, respectively.
64	DA03	O	When PSSL = "H" or "L", DA03 or C2F1 is output, respectively.
65	DA04	O	When PSSL = "H" or "L", DA04 or C2F2 is output, respectively.
66	DA05	O	When PSSL = "H" or "L", DA05 or C2FL is output, respectively.
67	DA06	O	When PSSL = "H" or "L", DA06 or C2PO is output, respectively.
68	DA07	O	When PSSL = "H" or "L", DA07 or RFCK is output, respectively.
69	DA08	O	When PSSL = "H" or "L", DA08 or WFCK is output, respectively.
70	DA09	O	When PSSL = "H" or "L", DA09 or PLCK is output, respectively.
71	DA10	O	When PSSL = "H" or "L", DA10 or UGFS is output, respectively.
72	DA11	O	When PSSL = "H" or "L", DA11 or GTOP is output, respectively.
73	Vcc	—	Power supply (+ 5V)
74	DA12	O	When PSSL = "H" or "L", DA12 or RAOV is output, respectively.
75	DA13	O	When PSSL = "H" or "L", DA13 or C4LR is output, respectively.
76	DA14	O	When PSSL = "H" or "L", DA14 or BCLK is output, respectively.
77	DA15	O	When PSSL = "H" or "L", DA15 or BCLK is output, respectively.
78	DA16	O	When PSSL = "H", DA16 (MSB of parallel sound data) is output. When PSSL = "L", DATA is output.
79	WDCK	O	Strobe signal output. When DF is ON, the frequency is 176.4 kHz (352.8 kHz when replayed at the double speed). When DF is OFF, it is 88.2 kHz (176.4 kHz when replayed at the double speed).
80	LRCK	O	Strobe signal output. When DF is ON, the frequency is 88.2 kHz (176.4 kHz when replayed at the double speed). When DF is OFF, it is 44.1 kHz (88.2 kHz when replayed at the double speed).

Terminal Function <CXP1001AQ>

Pin No.	Pin Name	I/O	Function	I/O Format
1	—		OPEN	
2	MUTE	O	MUTE is ON with mute output in "H". It is connected to MUTG ⑩ of CXD 1167.	Output of pull-up resistance
3, 4	—	I	Connected to Vss.	
5	SQCK	O	Output of clock for reading subcode Q. It is connected to SQCK ⑫ of CXD1167.	3-state output
6, 7	—		OPEN	
8	SUBQ	I	Data input of subcode Q. It is connected to SUBQ ⑬ of CXD 1167.	Schmidt Inverter input
9	REMAIN	I	REMAIN (remaining time) indication switching input KEY is connected.	Inverter input
10	OPEN	I	Connect the OPEN/CLOSE detection switch on the lid of the CD player and adjust it to open upon "L".	
11	—		Connected to Vss.	
12	FOK	I	Enter whether focusing is OK. It is connected to FOK ⑭ of CXA1081.	Inverter input
13	CUE	I	Connect >> KEY.	
14	SEV	I	Connect << KEY.	
15	MEMORY	I	Connect MEMORY KEY.	
16	REPEAT	I	Connect REPEAT KEY.	
17	PLAY	I	Connect ▷/⏸ (PLAY/PAUSE) KEY.	
18	STOP	I	Connect ■ (STOP) KEY.	
19	FFS	I	Connect ▷> KEY.	
20	FRS	I	Connect <<< KEY.	
21	TEST	I	Enter TEST mode.	
22	—		Connected to Vdd.	
23	EMPHASIS	O	Emphasis output. "H" when emphasis is ON. Connected to the analog audio system.	3-state output
24	SENS	I	Sense input (various system monitor) terminal. Connected to SENS ⑯ of CXD1167 and ⑰ of CXA1082.	Inverter input

Pin No.	Pin Name	I/O	Function	I/O Format
25	Vss		Vss terminal	
26	—	I	Connected to Vdd.	
27	XRST	O	System reset output. Connected to XRST ⑱ of CXD1167 and ⑲ of CXA1082.	3-state output
28	CLK	O	System control clock output. Connected to CLK ⑳ of CXD1167 and ㉑ of CXA1082.	
29	XLT	O	System control latch output. Connected to XLT ㉒ of CXD1167 and ㉒ of CXA1082	
30	DATA	O	System control data output. Connected to DATA ㉓ of CXD1167 and ㉓ of CXA1082.	
31	SEG19	O	For the drive output (segment) indication pattern of the liquid crystal display (LCD), see the attached sheet.	Segment output
50	SEG0			
51	—		OPEN	
52	COM2	O	For the drive output (common) indication pattern of the LCD, see the attached sheet.	Segment output
54	COM0			
55	Vlc1		Terminal to supply bias voltage for the LCD	
57	Vlc3			
58	Vdd		Vdd terminal	
59	Vl		Terminal to supply bias voltage for the LCD	
60	—		OPEN	
61	C4M	I	4.2336 MHz clock input terminal. Connected to C4M ⑳ of CXD1167.	Clock input
62	RESET	I	Reset input	Reset
63	—		Connected to Vss.	
64	SCOR	I	Subcode sync (SCOR) input. Connected to SCOR ㉔ of CXD1160.	Schmidt inverter input

• CXA1081M <RF Amp.>

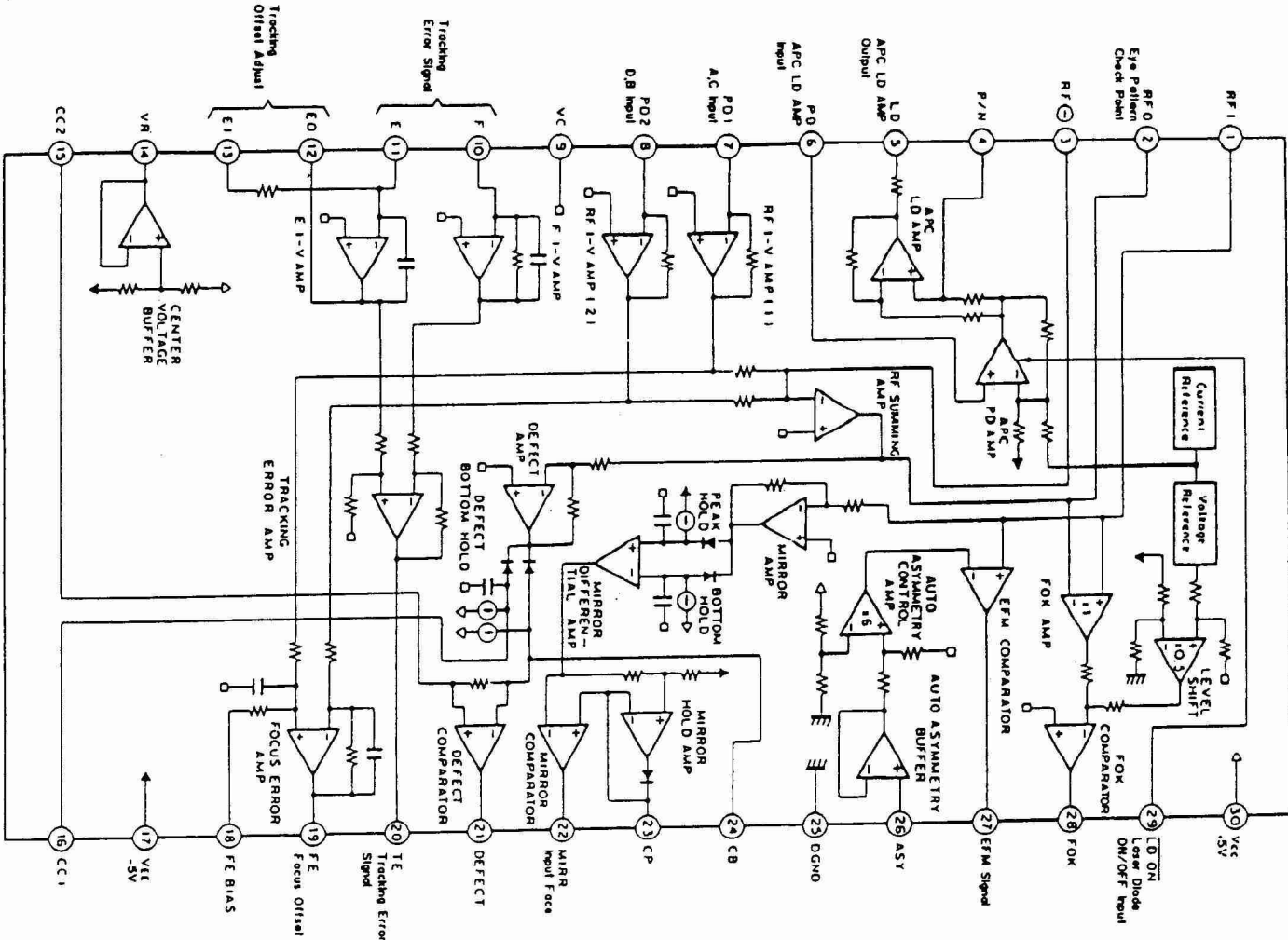

◆ Terminal Function <CXA1081M>

Pin No.	Pin Name	I/O	Description
1	RFI	I	RF summing amplifier input.
2	RFO	O	RF summing amplifier input.
3	RF ⊖	I	RF Summing amplifier feedback signal input.
4	P/N	I	Terminal for switching P-sub/N-sub of LD (laser diode).
5	LD	O	APC LD amplifier output.
6	PD	I	APC PD amplifier input.
7	PD1	I	RF I-V amplifier (1) inverting input. This terminal is connected to the pin diode (A + C).
8	PD2	I	RF I-V amplifier (2) inverting input. This terminal is connected to the pin diode (B + D).
9	VC	-	Ground
10	F	I	F I-V amplifier inverting input. This terminal is connected to the pin diode (F).
11	E	I	E I-V amplifier inverting input. This terminal is connected to the pin diode (E).
12	EO	O	E I-V amplifier output.
13	EI	I	E I-V amplifier feedback input.
14	VR	O	(Vcc + VEE)/2 voltage output.

Pin No.	Pin Name	I/O	Description
15	CC2	I	Defect amplifier bottom hold input. This terminal is connected Pin 16 with a coupling capacitor.
16	CC1	O	Defect amplifier bottom hold output.
17	VEE	-	Negative supply voltage: -5V.
18	FEBIAS	I	Bias terminal for the focus error amplifier non-inverting.
19	FE	O	Focus error amplifier output.
20	TE	O	Tracking error amplifier output.
21	DEFECT	O	Defect comparator output.
22	MIRR	O	Mirror comparator output.
23	CP	I	Mirror comparator non-inverting input. This terminal is connected a mirror hold capacitor.
24	CB	I	This terminal is connected a defect bottom hold capacitor.
25	DGND	-	Ground.
26	ASY	I	Auto asymmetry buffer control signal input.
27	EFM	O	EFM comparator output.
28	FOK	O	FOK comparator output.
29	LD ON	I	Laser diode ON/OFF switching input.
30	Vcc	-	Positive supply voltage: +5V.

• MN6474M <D/A Converter>

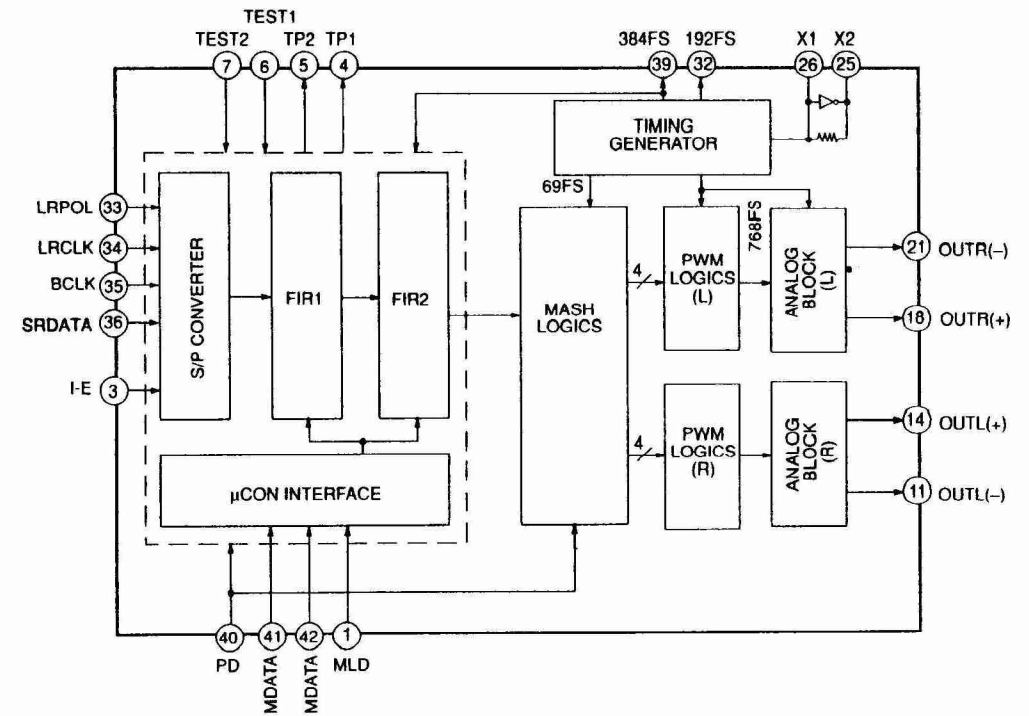

◆ <Function> (MN6474M)

Pin No.	Pin Name	Function
1	MLD	Microcomputer command load input (load when at ⊕)
2	RSTB	Reset terminal (active when at ⊕)
3	IE	When at ⊕ — Signal processor LSI format When at ⊖ — I ² S format
10	AV _{DD} 4	Analog system power source terminal 4 (+5V)
11	OUTL (-)	Left channel antiphase PWM output terminal
12	AV _{SS} 4	Analog system ground terminal 4
13	AV _{SS} 3	Analog system ground terminal 3
14	OUTL (+)	Left channel normal phase PWM output terminal
15	AV _{DD} 3	Analog system power source terminal 3 (+5V)
17	AV _{DD} 2	Analog system power source terminal 2 (+5V)
18	OUTR (+)	Right channel antiphase PWM output terminal
19	AV _{SS} 2	Analog system ground terminal 2
20	AV _{SS} 1	Analog system ground terminal 1
21	OUTR (-)	Right channel normal phase PWM output terminal
22	AV _{DD} 1	Analog system power source terminal 1 (+5V)
23	DV _{DD} 1	Digital system power source terminal 1 (+5V)
24	DV _{SS} 1	Digital system ground terminal 1

Pin No.	Pin Name	Function
25	X2	X'tal oscillation terminal
26	X1	X'tal oscillation terminal
28	DV _{DD} 2	Digital system power source terminal 2 (+5V)
29	DV _{SS} 2	Digital system ground terminal 2
30	NSUB	Connected to D-V _{DD} (silicone PCB potential stabilizer terminal)
32	192FS	192 FS (=8.4672 MHz) output terminal
33	LRPOL	Left/right channel switching terminal (⊕ is left channel, ⊖ is right channel)
34	LRCLK	LRCLK input terminal LR-POL when at ⊕: ⊕ is left channel data input, ⊖ is right channel data input LR-POL when at ⊖: ⊖ is right channel data input, ⊕ is left channel data input
35	BCLK	Serial input bit clock
36	SRDATA	Serial input data (digital) input terminal
37	DV _{SS} 3	Digital system ground terminal 3
38	DV _{DD}	Digital system power source terminal (COM potential stabilizer terminal)
39	384FS	384 FS (=16.9344 MHz) output terminal
40	PD	Power down terminal (⊕ is active)
41	MDATA	Microcomputer command data input terminal
42	MCLK	Microcomputer command clock input terminal

5. PARTS LIST OF BOARD

5-1. F-6521 Main Board <Stock No. 01252101>

Parts No.	Stock No.	Description
•Transistor		
fQ1	46359701	2SA952
fQ2	46367101	2SC2603
	or 46367301	2SC2458
	or 48058801	2SC1740S
fQ3	46359801	2SC2001
fQ4	46359701	2SA952
fQ5	46359801	2SC2001
fQ6	46359701	2SA952
fQ7	46359801	2SC2001
fQ8	46359701	2SA952
fQ9	46359801	2SC2001
fQ10	46359701	2SA952
•IC		
fIC1	49554800	CXA1081M
fIC2	49379400	CXA1082BQ
fIC3	49552800	CXD1167Q
•Diode		
fD1	46464100	1SS133
fC24	48748400	0.1 μ F 50V C.C.
fC31	48748400	0.1 μ F 50V C.C.
fC37	48748400	0.1 μ F 50V C.C.
fL1	48289400	10 μ H Inductor
fL2	48289800	22 μ H Inductor
fVR1	83216600	20k Ω B S.V.R., T BIAS
fVR2	83216500	10k Ω B S.V.R., FE BIAS
fVR3	83216600	20k Ω B S.V.R., F Gain
fVR4	83216600	20k Ω B S.V.R., T Gain
fVR5	83216300	2k Ω B S.V.R., VCO
•Transistor		
mQ1	46359801	2SC2001
mQ2	46359701	2SA952
Δ mQ3	46359801	2SC2001
Δ mQ4	46359701	2SA952
•Diode		
Δ mD1	83005000	1N4002
Δ mD2	83005000	1N4002
Δ mD3	83005000	1N4002
Δ mD4	83005000	1N4002
•Zener Diode		
mDZ1	48552400	MTZ5.6B
	or 48631200	RD5.6B2 ES
mDZ2	48552400	MTZ5.6B
	or 48631200	RD5.6B2 ES
nLC1	83229900	Liquid Crystal Display
•Transistor		
vQ1	46604301	2SC3327
vQ2	46604301	2SC3327
vQ3	46367001	2SA1115
	or 46367201	2SA1048
	or 48058601	2SA933S
vQ4	46367001	2SA1115
	or 46367201	2SA1048
	or 48058601	2SA933S

<F-6521>

Parts No.	Stock No.	Description
•IC		
vIC1	49543400	MN6474M
vIC2	49373100	BA15218N
	or 49439500	NJM4558L
	or 49541200	M5218AL
vXO1	49357400	Quartz Element HC-49/U
•Diode		
vD1	46464100	1SS133
vD2	46464100	1SS133
vC1	48748400	0.1 μ F 50V C.C.
vC3	48748400	0.1 μ F 50V C.C.
vL1	48289400	10 μ H Inductor
•Transistor		
wQ1	46367101	2SC2603
	or 46367301	2SC2458
	or 48058801	2SC1740S
wQ4	46367101	2SC2603
	or 46367301	2SC2458
	or 48058801	2SC1740S
wQ5	46359701	2SA952
wQ6	46359701	2SA952
wQ7	46359801	2SC2001
wQ8	46359801	2SC2001
•IC		
wIC1	49554900	CXP1001AQ
•Diode		
wD1	46464100	1SS133
wD2	46464100	1SS133
wD3	46464100	1SS133
•Zener Diode		
wDZ1	48552400	MTZ5.6B
	or 48631200	RD5.6B2 ES
wDZ2	48552400	MTZ5.6B
	or 48631200	RD5.6B2 ES
wC4	48748400	0.1 μ F 50V C.C.
Δ wR14	46401600	4.7 Ω 1/2W N.I.R.

5-2. F-6522 Pilot Lamp Board

Parts No.	Stock No.	Description
nPL1	83274300	Pilot Lamp, 5V 0.15A

5-3. F-6523 Input Key Switch Board <Stock No. 01252401>

Parts No.	Stock No.	Description
oS1	46708100	Push SW., \lll
	or 48306900	Push SW., \lll
oS2	46708100	Push SW., \ggg
	or 48306900	Push SW., \ggg

to be continued

<F-6523>

Parts No.	Stock No.	Description
oS3	46708100	Push SW., □
	or 48306900	Push SW., □
oS4	46708100	Push SW., ▷/▢
	or 48306900	Push SW., ▷/▢
oS5	46708100	Push SW., REPEAT
	or 48306900	Push SW., REPEAT
oS6	46708100	Push SW., PROG
	or 48306900	Push SW., PROG
oS7	46708100	Push SW., ◀◀
	or 48306900	Push SW., ◀◀
oS8	46708100	Push SW., ▶▶
	or 48306900	Push SW., ▶▶
oS9	46708100	Push SW., o/c
	or 48306900	Push SW., o/c
wIC52	49356200	Remote Receive Unit GP1U521X
	or 49550900	Remote Receive Unit GP1U521X
•Transistor wQ51	48230600	DTC144WS
•IC wIC51	49562200	LC6543C-4479
•Diode wD51	46464100	1SS133

5-4. F-6524 LINE OUT Board

Parts No.	Stock No.	Description
oJ1	49320500	2P Terminal Board, LINE OUT
oJ2	83265100	SYNCRO Terminal

6. PARTS LOCATION ON BOARD

6-1. F-6521 Main Board Component side

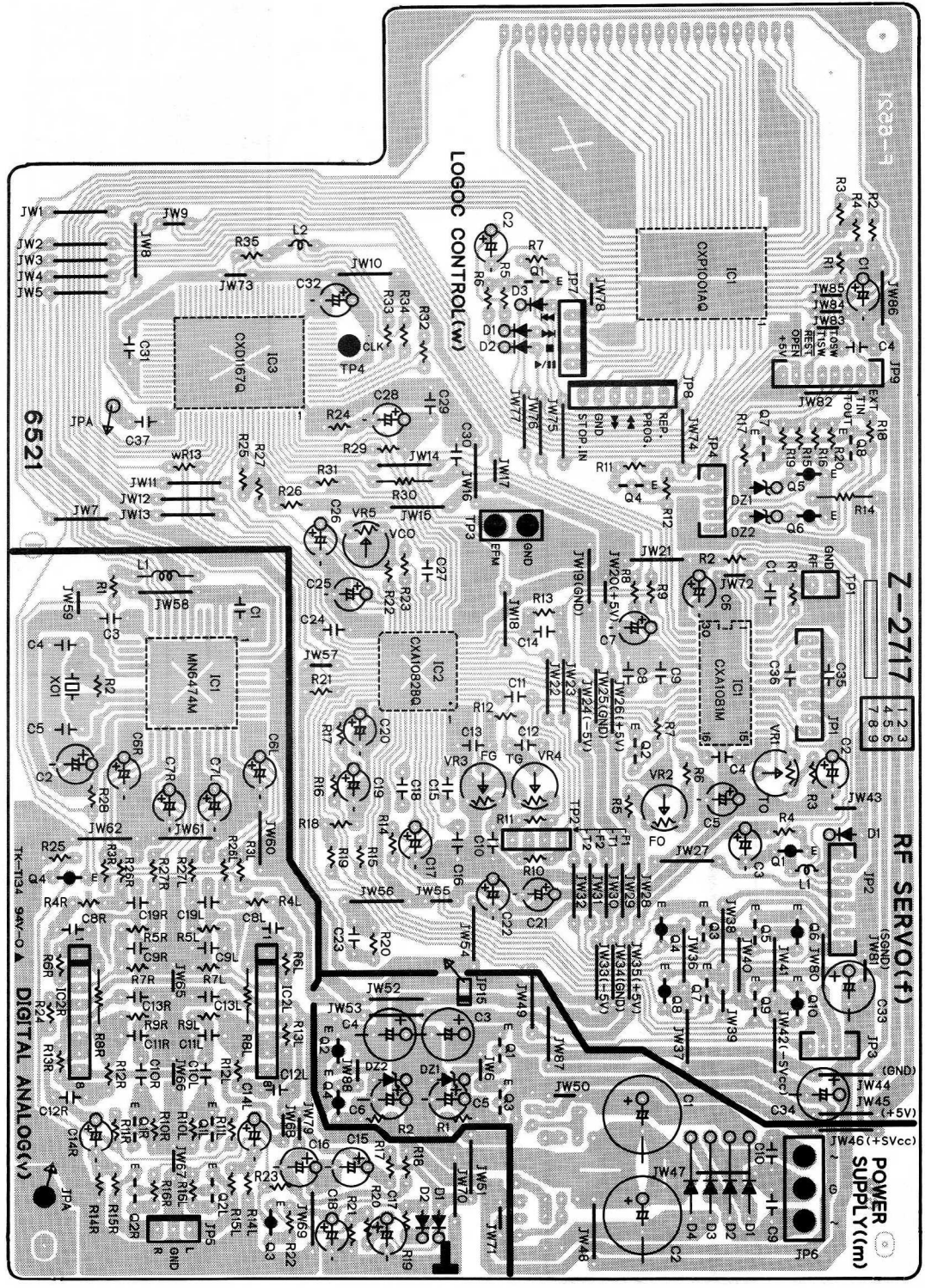

6-2. F-6523 Input Key Switch Board
Component side

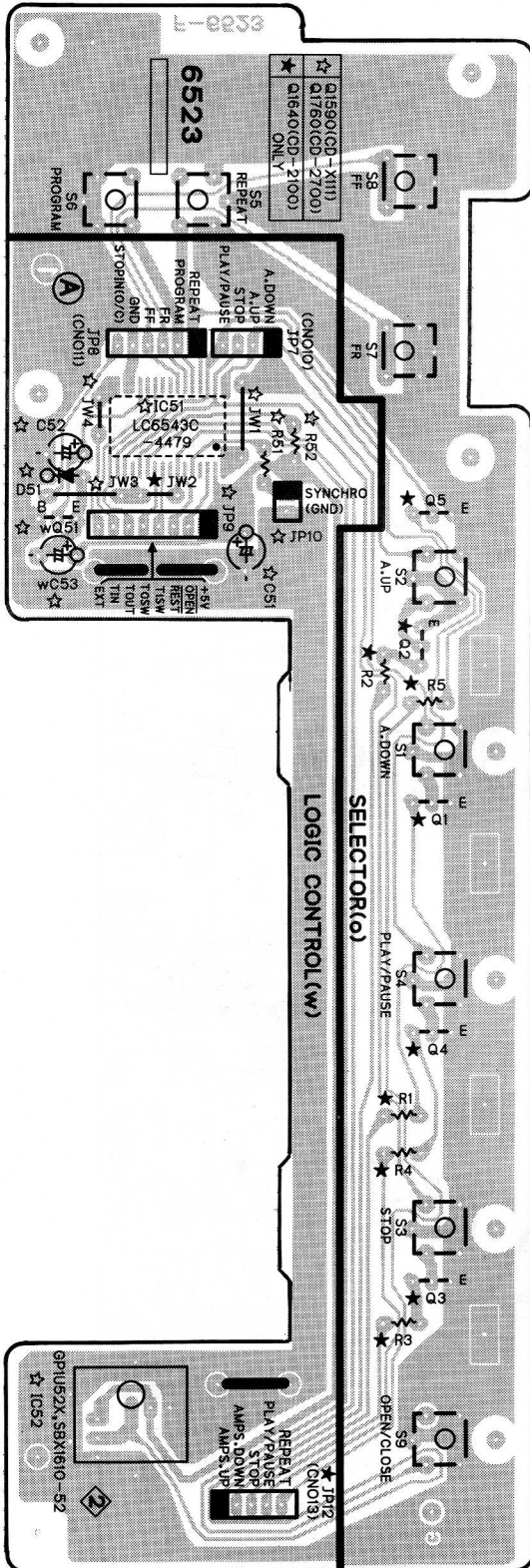

6-3. F-6524 LINE OUT Board
Component side

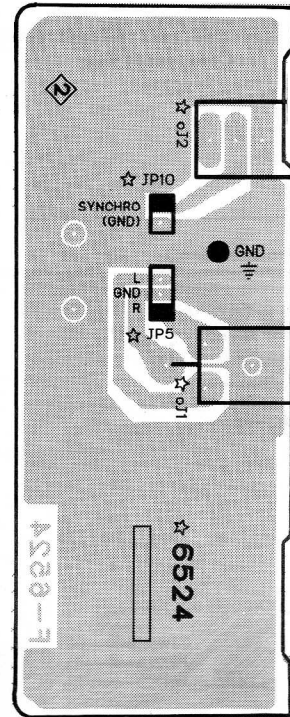

6-4. F-6522 Pilot Lamp Board

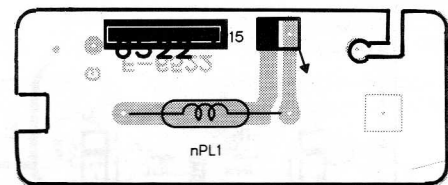

7. SCHEMATIC DIAGRAM

* Design and specifications subject to changes without notice for improvements.

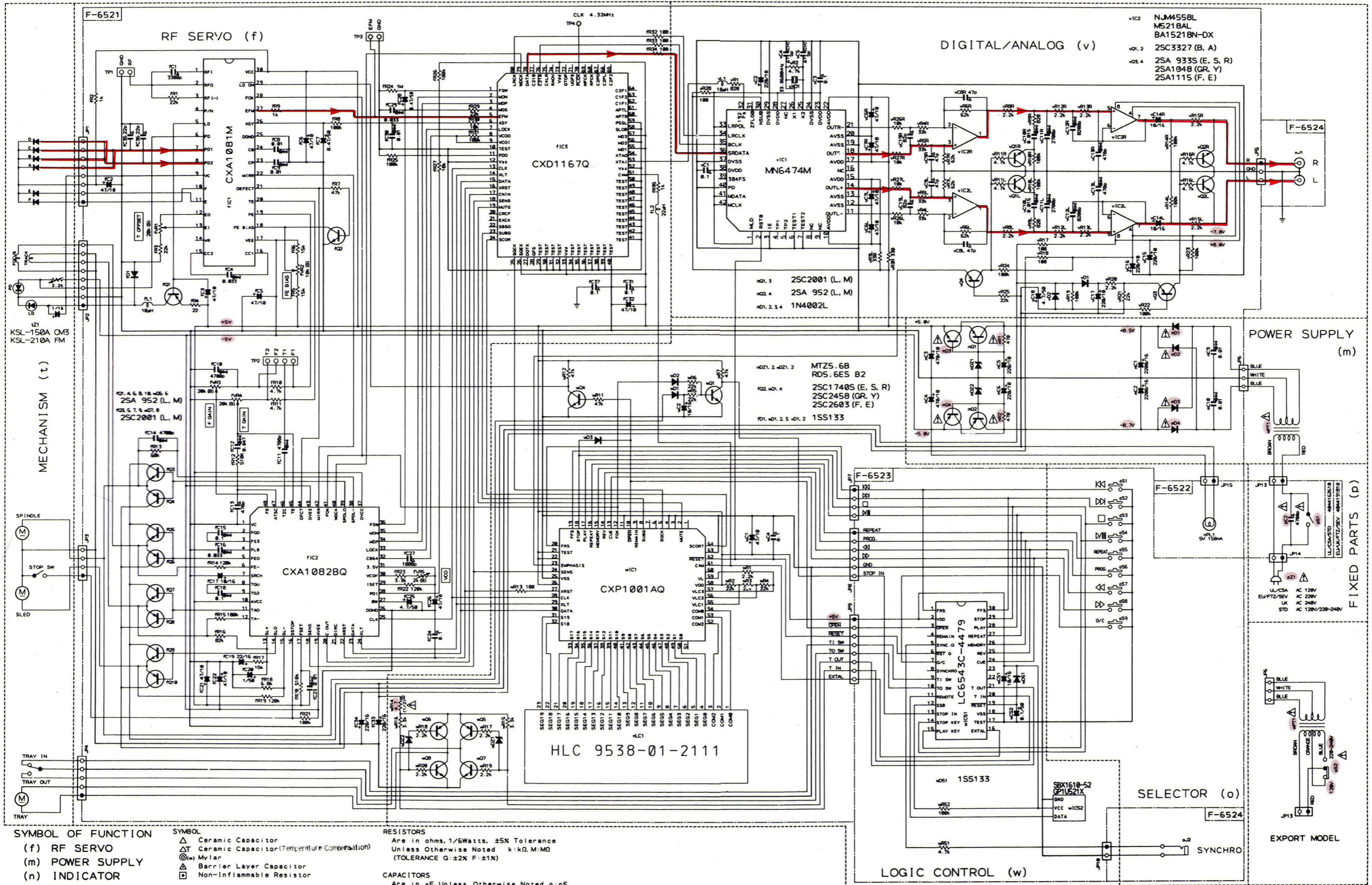

- 1 1N4002 1SS133
- 2 RD5.6ES 2SA952, 2SA2001
- 3 2SA1048, 2SA1115, 2SA933S, 2SC1740S, 2SC2603
- 4 2SC2458, 2SC327
- 5 M5218AL, NJM4558L
- 6 CXA1081M
- 7 CXP1001AQ, MN6474M, CXA1082BQ
- 8 CXD1167Q

- SYMBOL OF FUNCTION**
- (f) RF SERVO
 - (m) POWER SUPPLY
 - (n) INDICATOR
 - (o) SELECTOR
 - (t) MECHANISM
 - (v) DIGITAL/ANALOG
 - (w) LOGIC CONTROL

- SYMBOL**
- Ceramic Capacitor
 - Ceramic Capacitor (Temperature Compensation)
 - Mylar
 - Barrier Layer Capacitor
 - Non-Inflammable Resistor
 - is Safety Part. Use only replacement parts recommended by the manufacturer.

- RESISTORS**
- Are in ohms, 1/6Watts, ±5% Tolerance Unless Otherwise Noted k:kΩ, M:MΩ (TOLERANCE G:±2% F:±1%)
- CAPACITORS**
- Are in μF, Unless Otherwise Noted p:pF
- ELECTROLYTIC CAPACITORS**
- Capacitance (μF)/Volt (V)
- Each D.C. Voltage shows the nominal value in volts at during playing.

Signal Line

1
2
3
4
5

8. OTHER PARTS

• CD Mechanism Ass'y

(Type No. KSL-150A CM3 Stock No. C486040394 or KSL-150A CM4 Stock No. C486040393 or KSL-210AFM Stock No. C486040382)

Use this list for reference only.
Parts not available separately.

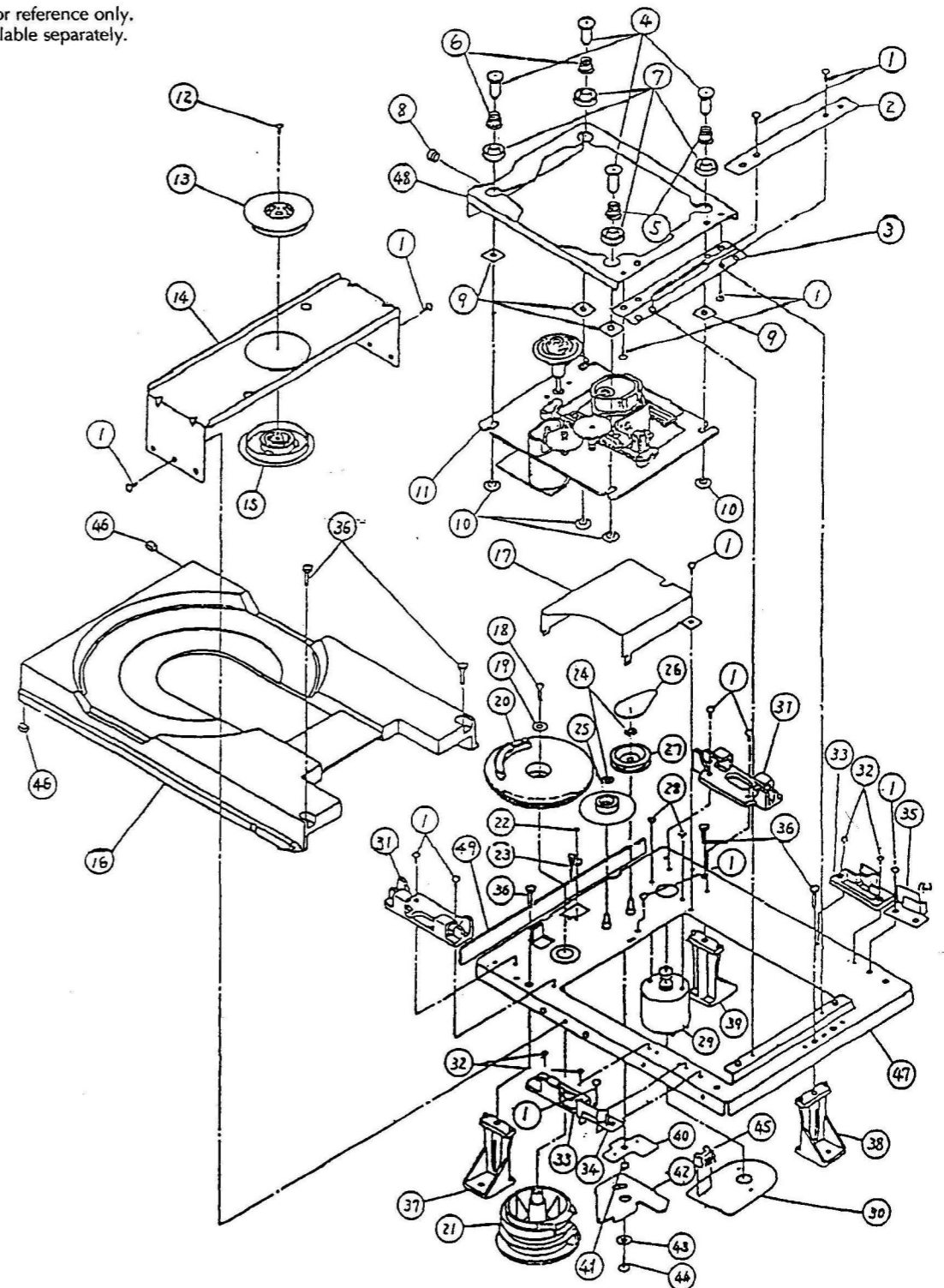

• TOP VIEW

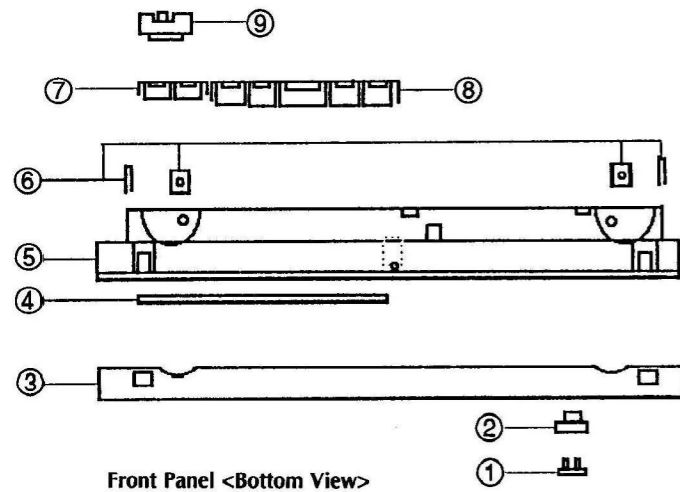
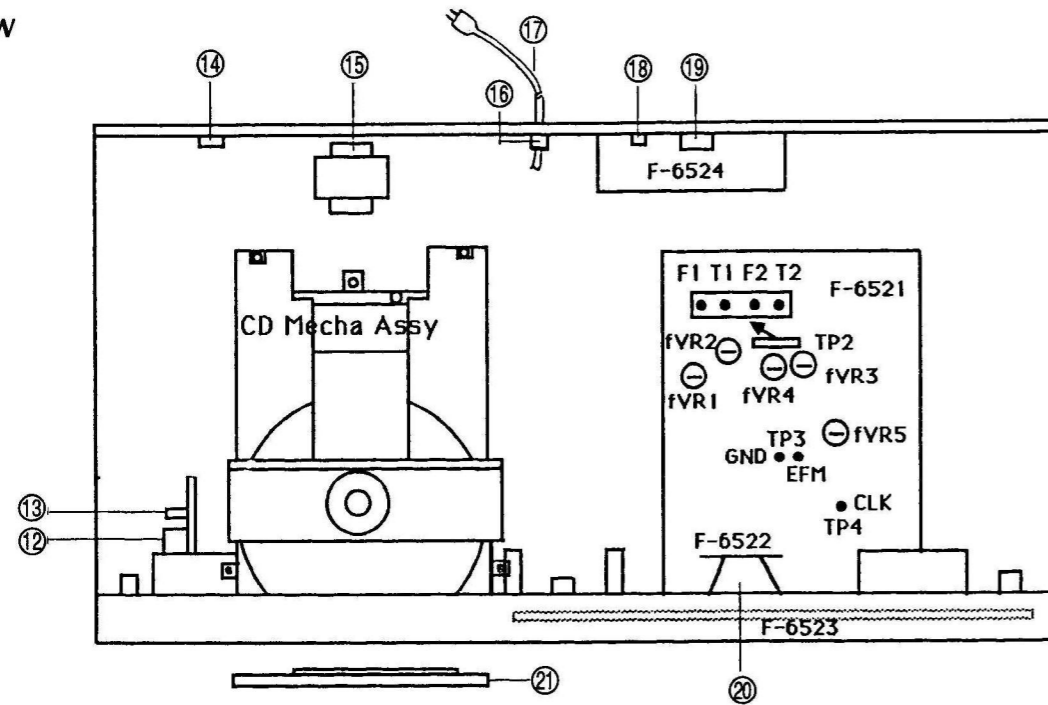

Bonnet <Side View>

Front Panel <Bottom View>

<Parts List>

Parts No.	Stock No.	Description	Parts No.	Stock No.	Description
1	JS27893300	Logo Badge	△ 14	4420131260	Voltage Selector <XX, SS>
2	JS65013300	Power Switch Knob	△ 15	420A481208	Power Transformer
3	1001038402	AL Panel <CD-X111 only>	△	420A484216	Power Transformer <EG, EU, SEV>
3+(5)+(6)	0001038403	P. Panel Ass'y <CD-2700 only>	△	420A489217	Power Transformer <XX, SS>
4	JS85008300	Display Plate	△	420A482208	Power Transformer <CSA>
5+(6)	0001038402	P. Panel Ass'y <CD-X111 only>	△	420A485209	Power Transformer <UK>
6	2017718300	Escushon Nut	16	4580200006	Cord Stopper <XX, SEV, EG, UK, EU>
7	JS85008100	Sub Key Knob <CD-X111>		4580100001	Cord Stopper <SS, CSA, UL>
	JS85015600	Sub Key Knob <CD-2700>	△ 17	4631112070	Power Cord <SS, CSA, UL>
8	JS85008000	Main Key Knob <CD-X111>	△	4632212080	Power Cord <EG, EU>
	JS85016300	Main Key Knob <CD-2700>	△	463021L065	Power Cord <XX>
9	JS85008200	Mode Knob	△	4633202080	Power Cord <UK, SEV>
10	0002078910	Leg Ass'y	18	4500100178	SYNC. Terminal
11	1003038100	Bonnet	19	4500800294	LINE OUT Terminal
△ 12	4430102450	Power Switch	20	2001079329	Display Holder
△ 13	5106472141	4700pF 400V C.C.	21	JS85008400	Display Plate



SANSUI ELECTRIC CO., LTD.:

SANSUI USA INC.:

SANSUI DEUTSCHLAND G.M.B.H.:

山水電気株式会社

New River Bldg. 10-14, Shinkawa 1-chome, Chuo-ku, Tokyo 104, Japan
PHONE: (03) 5566-1024 / FAX: 03-5566-1027 (International Division)
1250 Valley Brook Ave. Lyndhurst, N.J. 07071 U.S.A.
17150 South Margay Ave. Carson, California 90746 U.S.A.
Paul-Ehrlich-Strasse 8, 6074 Rödermark 2, West Germany

東京都中央区新川1-10-14 (〒104)