

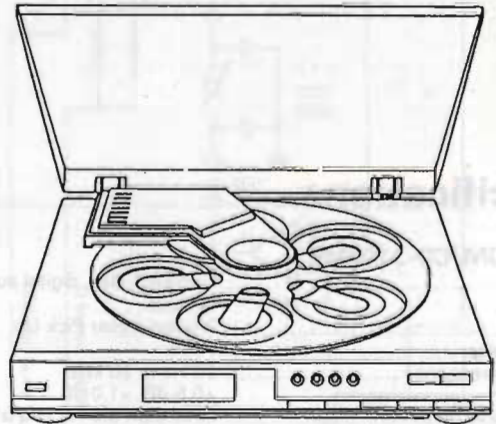



# SERVICE MANUAL

## CD-3100M CD-3100ME CD-570M CD-570ME

COMPACT DISC AUTO  
CHANGER



### CAUTION

1. Parts identified by the  symbol on the schematic diagram and the parts list are critical for safety. Use only replacement parts that have critical characteristics recommended by the manufacturer.
2. Make leakage-current or resistance measurements to determine that exposed parts are acceptably insulated from the supply circuit before returning the appliance to the customer.

### Cautions Concerning Handling of The Laser

The following label has been affixed to the unit, listing the proper procedure for working with the laser beam.

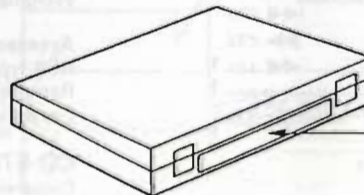

(UL, SS, and XX model only)

PRODUCT COMPLIES WITH DHHS  
RULES 21 CFR, SUBCHAPTER J,  
PART 1040. 10.  
MANUFACTURED:

(CSA model only)

CERTIFIED ONLY TO CANADIAN  
ELECTRICAL CODE.  
CERTIFIÉ EN VERTU DU CODE  
CANADIAN DE L'ÉLECTRICITÉ  
SEULEMENT.

(EU model only)

**CLASS 1  
LASER PRODUCT**

(EU model only)

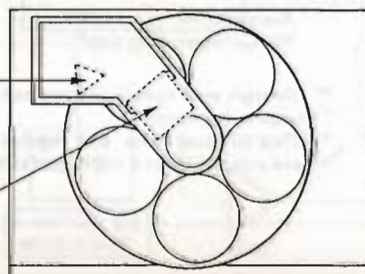
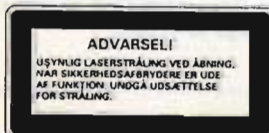



**NOTICE**

- The symbols UL, CSA, EU, SS and XX <EXPORT> on the parts list and the schematic diagram mean followings respectively.  
UL..... Manufactured for U.S.A. market.  
(Underwriters Laboratories approved model.)  
CSA..... Manufactured for Canadian market.  
EU..... Manufactured for European market.  
SS..... Manufactured for Saudi Arabian market.  
XX..... Standard Version.  
<EXPORT>  
NON MARK..... Common Parts.

- Some printed circuit boards are not supplied assembled. To separate these in this service manual, the stock numbers are not indicated for these boards. However, stock numbers for individual parts are indicated.
- Since some capacitors and resistors are omitted from parts lists in this service manual, refer to the Common Parts List for capacitors and resistors, which was issued on June 1987.
- Abbreviations in this service manual are as follows.

Abbreviations List			
N.I.R. : Non-Inflammable Resistor	S.V.R. : Semi Variable Resistor	SW. : Switch	
C.C. : Ceramic Capacitor	E.B. : Bi-Polar Electrolytic Capacitor		
E.C. : Electrolytic Capacitor			

**Specifications**

**CD-3100M/CD-3100ME**

Formation.....	Compact disk, digital audio system
Pick Up.....	3-beam Laser Pick Up
D/A Converter.....	16bit
Frequency response.....	20 Hz to 20 kHz +0.5 dB, -1.0 dB
Ttal harmonic distortion.....	Less than 0.04% (1kHz)
Signal-to-Noise Ratio.....	98 dB more
Dynamic Range.....	92dB more
Wow & Flutter.....	Below measurement threshold
Output Voltage.....	2 V(RMS)
Power consumption.....	AC 120V/220V-240V, 50/60 Hz
For U.S.A & Canada.....	AC 120V, 60 Hz
European.....	220V, 50 Hz
United kingdom.....	240V, 50 Hz
Rated power consumption.....	15 Watts

**CD-570M/CD-570ME**

Formation.....	Compact disk, digital audio system
Pick Up.....	3-beam Laser Pick Up
D/A Converter.....	16bit
Frequency response.....	20 Hz to 20 kHz +0.5 dB, -1.0 dB
Ttal harmonic distortion.....	Less than 0.04% (1kHz)
Signal-to-Noise Ratio.....	98 dB more
Dynamic Range.....	92dB more
Wow & Flutter.....	Below measurement threshold
Output Voltage.....	2 V(RMS)
Power consumption.....	AC 120V/220V-240V, 50/60 Hz
For U.S.A & Canada.....	AC 120V, 60 Hz
European.....	220V, 50 Hz
United kingdom.....	240V, 50 Hz
Rated power consumption.....	15 Watts

**CD-3100M**

Dimensions(With Dust cover).....	420 mm (16-9/16") W 380 mm (15") D 112 mm (4-7/16") H
Weight(With Dust cover).....	3.9 kg (8.6 lbs) net 5.5 kg (12.1 lbs) packed

**Remote Controller**

Transmission Method.....	Infrared Rays Pulse System
Battery.....	*AAA(IEC R03) x 2 (DC3V)
Dimensions.....	60 mm (2-3/8") W 134.5mm (5-5/16") D 14 mm (9/16") H
Weight(Without Batteries).....	65 g (0.1 lbs)

**Accessories**

RCA-type pin-plug cord.....	1
Remote controller.....	1
Dry batteries.....	*AAA(IEC R03) x 2
Syncho cord.....	1

**CD-3100ME**

Dimensions(Without Dust cover).....	420 mm (16-9/16") W 380 mm (15") D 90 mm (3-9/16") H
Weight(Without Dust cover).....	3.3 kg (7.3 lbs) net 4.5 kg (9.9 lbs) packed

**Accessories**

RCA-TYPE Pin-plug.....	1
Syncho cord.....	1

**CD-570M**

Dimensions(With Dust cover).....	360 mm (14-3/16") W 380 mm (15") D 112 mm (4-7/16") H
Weight(With Dust cover).....	3.6 kg (7.9 lbs) net 4.7 kg (10.4 lbs) packed

**Remote Controller**

Transmission Method.....	Infrared Rays Pulse System
Battery.....	*AAA(IEC R03) x 2 (DC3V)
Dimensions.....	60 mm (2-3/8") W 134.5mm (5-5/16") D 14 mm (9/16") H
Weight(Without Batteries).....	65 g (0.1 lbs)

**Accessories**

RCA type pin plug cord.....	1
Remote controller.....	1
Dry batteries.....	*AAA(IEC R03) x 2

**CD-570ME**

Dimensions(With Dust cover).....	360 mm (14-3/16") W 380 mm (15") D 112 mm (4-7/16") H
Weight(With Dust cover).....	3.6 kg (7.9 lbs) net 4.0 kg (8.8 lbs) packed

**Accessories**

RCA-type pin-plug cord.....	1
-----------------------------	---

- Design and specifications subject to change without notice for improvements.
- Due to local laws and regulations, this unit sold in some areas are not equipped with variable voltage selectors.

**1. BLOCK DIAGRAM**

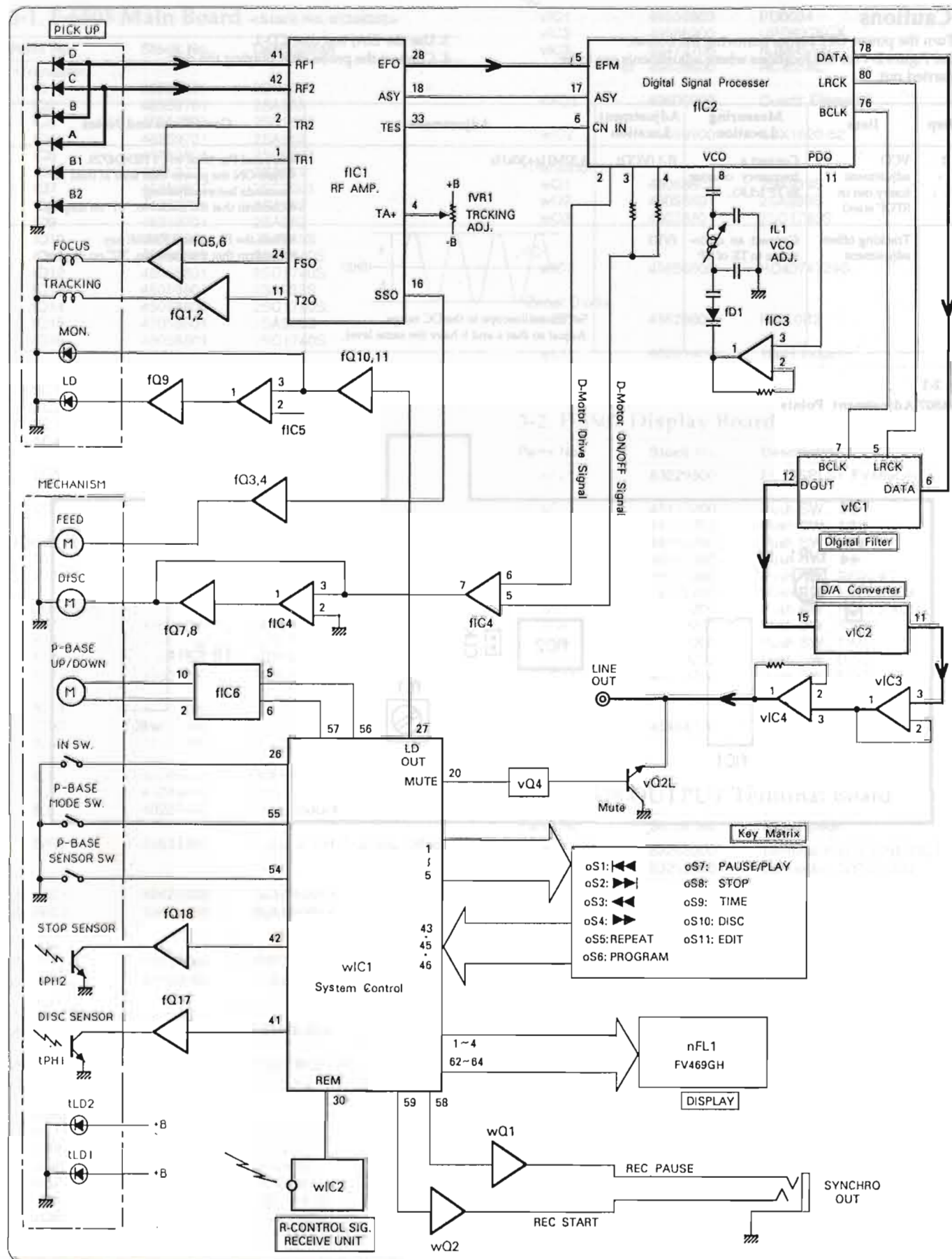



## 2. ADJUSTMENT METHOD

### • Cautions

1. Turn the power OFF before removing the bonnet.
2. See Figure 2-1 for the locations where adjustments are to be carried out.
3. Use the EIAJ test disc CD-1.
4. Connect the probe after playing the disc.

Step	Item	Measuring Location	Adjustment Location	Adjustment	Conditions and Notes
1	VCO adjustment (carry out in STOP state)	Connect a frequency counter to TP (CLK).	fL1 (VCO)	4.32MHz±30kHz	<ul style="list-style-type: none"> <li>• Ground Pin 18 of wIC1 HD404729.</li> <li>• Turn ON the power then wait at least 10 seconds before adjusting.</li> <li>• Confirm that the track No. "01" on display.</li> </ul>
2	Tracking offset adjustment	Connect an oscilloscope to TE of TP.	fVR1	 <p>Set the oscilloscope to the DC range. Adjust so that a and b have the same level.</p>	<ul style="list-style-type: none"> <li>• Push the PLAY and PAUSE key.</li> <li>• Confirm that the track No. "02" on display.</li> </ul>

Fig. 2-1  
•F-6507 Adjustment Points



## 3. PARTS LIST OF CIRCUIT

### 3-1. F-6505 Main Board <Stock No. 01246201>

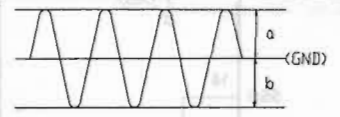
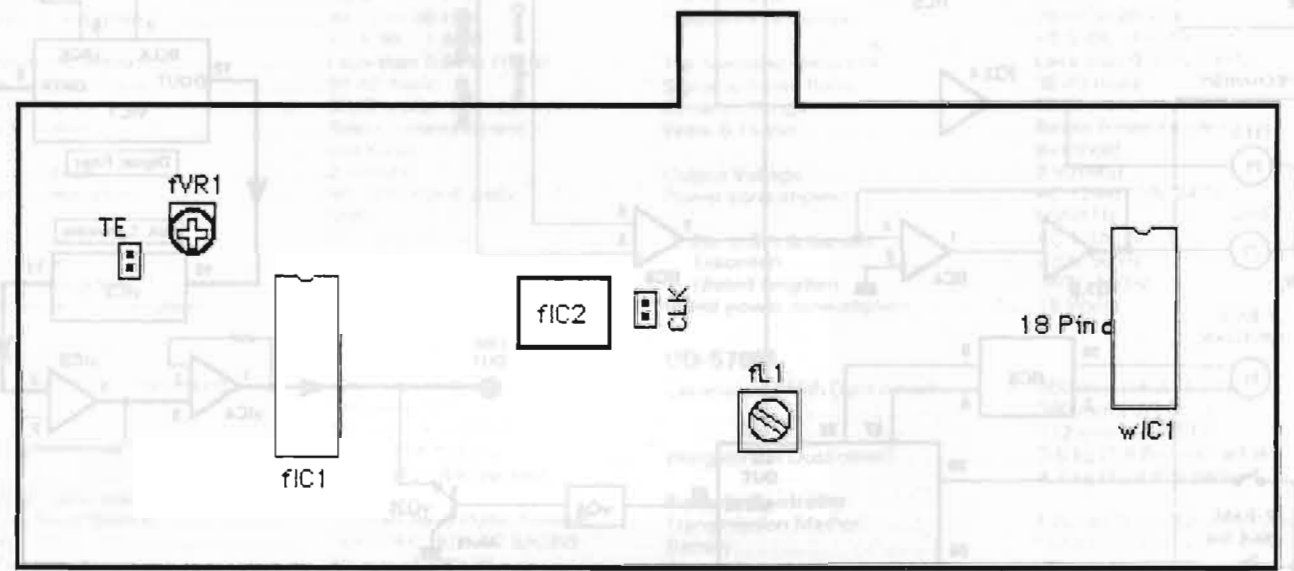
Parts No.	Stock No.	Description
•Transistor		
fQ1	46359801	2SC2001
fQ2	46359701	2SA952
fQ3	46359801	2SC2001
fQ4	46359701	2SA952
fQ5	46359801	2SC2001
fQ6	46359701	2SA952
fQ7	46359801	2SC2001
fQ8	46359701	2SA952
fQ9	46359701	2SA952
fQ10	48058601	2SA933S
fQ11	48058801	2SC1740S
fQ12	48058801	2SC1740S
fQ13	48058601	2SA933S
fQ14	48058801	2SC1740S
fQ15	48058601	2SA933S
fQ16	48058801	2SC1740S
•IC		
fIC1	49556800	HA12095NT
fIC2	49552800	CXD1167Q
fIC3	49395500	NJM2082L
fIC4	49472700	NJM4558L
	or 49623600	RC4558L
fIC5	49472700	NJM4558L
	or 49623600	RC4558L
fIC6	48982600	LB1641
•Diode		
fD1	49557000	SVC342
fD2-9	46464100	1SS133
•Zener Diode		
fDZ1	48628800	RD3.0B2
fDZ2	48631200	RD5.6B2
fDZ3	48631900	RD6.8B1
fDZ4	48631900	RD6.8B1
fC13	48103000	0.22μF 50V E.B.
fC30	48103400	1μF 50V E.B.
fC32	48103300	0.68μF 50V E.B.
fL1	83265400	AM RF Coil
fL2	48289400	10μH Inductor
fL3	48289400	10μH Inductor
fVR1	46634300	10kΩ S.V.R., Tracking Offset
•IC		
Δ mIC1	49420700	NJM7805FA
Δ mIC2	49474700	NJM7905FA
•Diode		
Δ mD1	03117000	RB152-LFF
Δ mD2	48123600	11E2
•Zener Diode		
Δ mDZ1	48612000	RD24B3ES
Δ mR1	46250500	1kΩ 1W N.I.R.
Δ mR4,5	46227100	2.7Ω 1/2W N.I.R.
•Transistor		
vQ1	46604301	2SC3327
vQ2	46604301	2SC3327
vQ3	48058601	2SA933S
vQ4	48058601	2SA933S
vQ5	48058801	2SC1740S
vQ6	48058801	2SC1740S

Parts No.	Stock No.	Description
•IC		
vIC1	49556900	PD0034
vIC2	49586300	UPD6376CX
vIC3	49472700	NJM4558L
	or 49623600	RC4558L
vXO1	49600000	Quartz Element
wIC2	49559900	SBX1620-52
•Transistor		
wQ1	48058601	2SA933S
wQ2	48058601	2SA933S
wQ3	48058801	2SC1740S
•IC		
wIC1	49556600	HD404729S
•Zener Diode		
wDZ1	48628800	RD3.0B2
wL1	48289400	10μH Inductor

### 3-2. F-6507 Display Board

Parts No.	Stock No.	Description
nFL1	83229500	FL DISPLSY FV469GH
•Diode		
oS1	48113200	Push SW., ▶▶▶
oS2	48113200	Push SW., ▶▶▶
oS3	48113200	Push SW., ▶▶▶
oS4	48113200	Push SW., ▶▶▶
oS5	48113200	Push SW., REPEAT
oS6	48113200	Push SW., PROGRAM
oS7	48113200	Push SW., PLAY/PAUSE
oS8	48113200	Push SW., STOP
oS9	48113200	Push SW., TIME
oS10	48113200	Push SW., DISC
oS11	48113200	Push SW., EDIT
•Diode		
wD1-5	46464100	1SS133

### 3-3. F-6508 OUTPUT Terminal Board

Parts No.	Stock No.	Description
oJ1	83265200	Terminal Board, LINE OUT
oJ2	83265500	Connector, SYNCHRO

### 3-4. F-6509 Power Switch Board

Parts No.	Stock No.	Description
Δ pC1	48733500	0.01μF 400V C.C.
Δ pS1	49198600	Push SW., POWER



# 4. EXPLODED VIEW OF MECHANIZM & PARTS LIST

## Exploded View of Mechanism (Type No. TCD-RM5CT Stock No. 0002104292)

Note: This mechanism is supplied assembled only, so individual parts are not supplied.  
Use this exploded view for reference only.

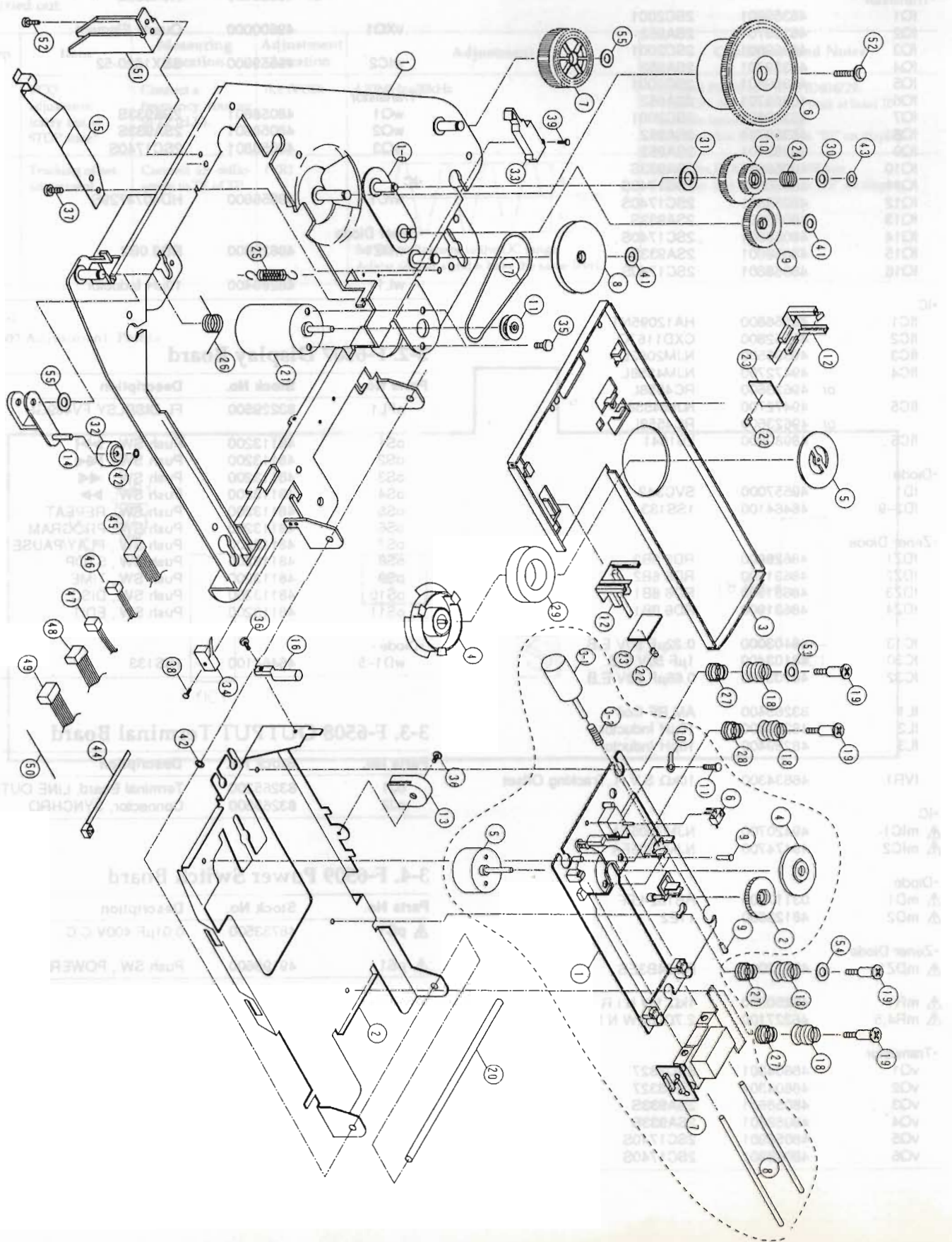



# 5. PARTS LOCATION ON BOARD

## 5-1. F-6505 Main Board

Component Side

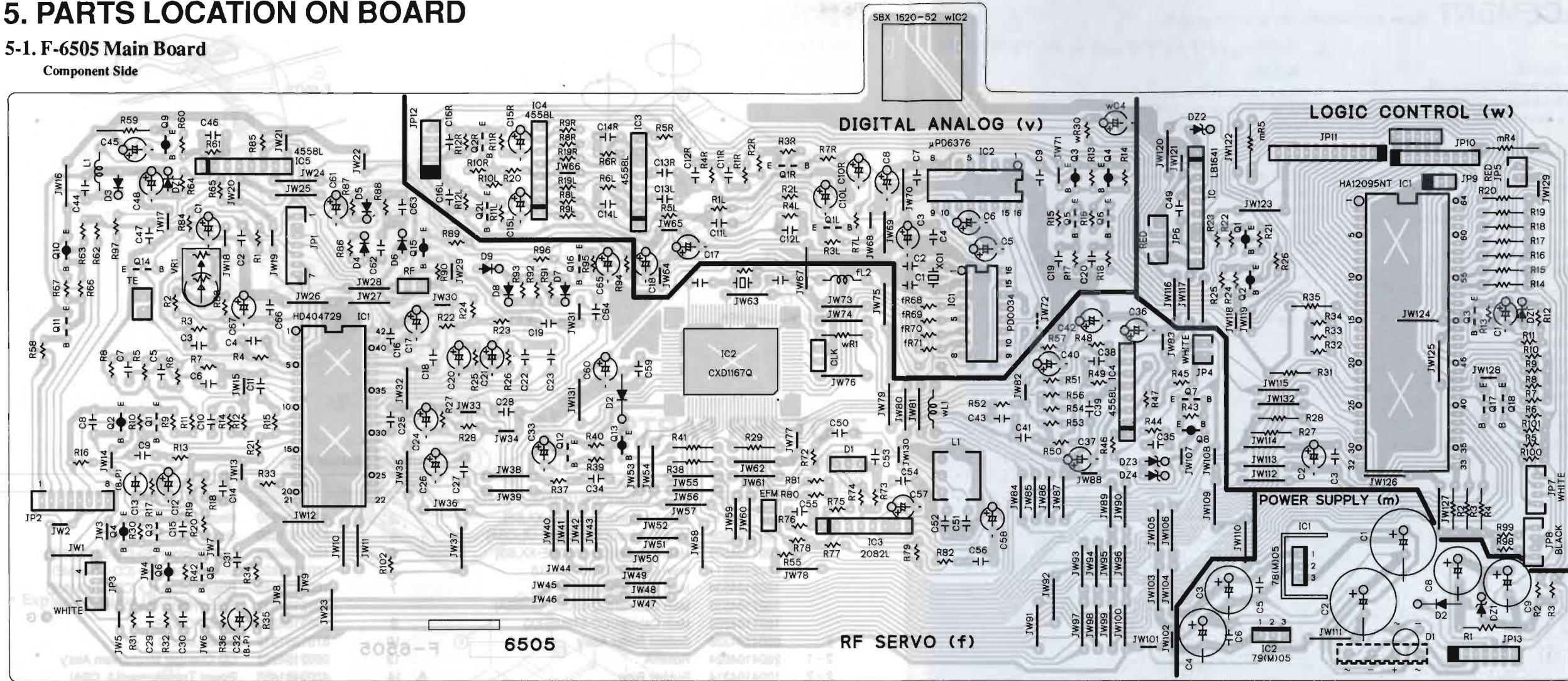

## 5-2. F-6506 Power Transformer

Component Side

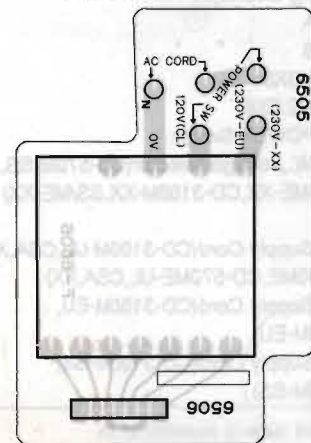

## 5-3. F-6507 Display Board

Component Side

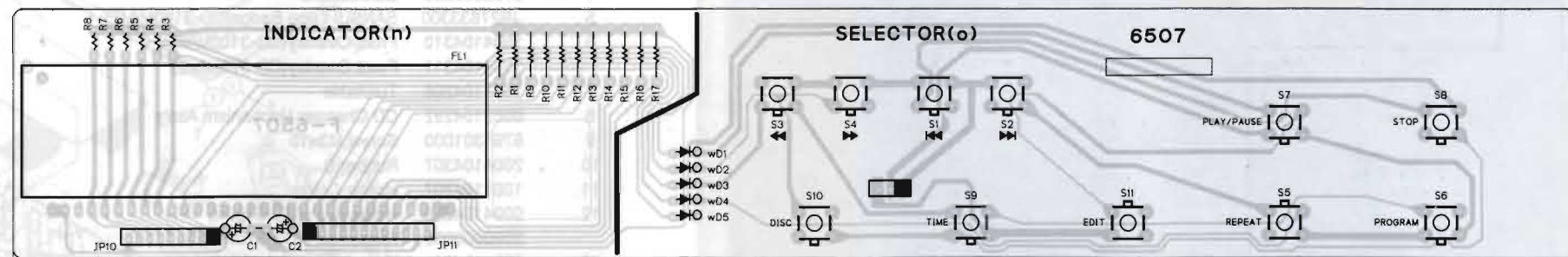

## 5-5. F-6509 Power Switch Board

Component Side

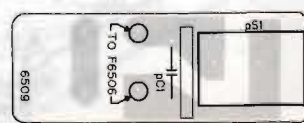

## 5-4. F-6508 OUTPUT Terminal Board

Component Side

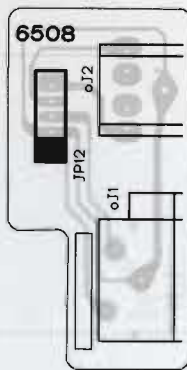

## 5-6. F-6510 STOP Sensor Board

Component Side



## 5-7. F-6568 Disc Sensor Board

Component Side





## 6. MAIN REPLACEMENT (Refer to Exploded View of set on page 8)

### A. CD Mechanism Ass'y

- 1) Unlock two stoppers (A & B). (See Fig. 6-4)
  - 2) Loosen seven screws (5) to remove the bottom cabinet (16).
  - 3) Loosen two screws (2) to remove a holder cover (11).
  - 4) Loosen three screws (9) to remove a clamber holder (8).
- Note: Do not injure a cabinet.
- 5) Unhook two stoppers to remove sensors with board (SP-13A) on clamber holder. (See Fig. 6-1)
  - 6) Pull out two sensors with board through a hole of a clamber holder and a main cabinet.
  - 7) Unfasten two connectors at pick-up terminals on the mechanism.
  - 8) Loosen five screws (5) to remove the PC board, F-6505 (12).
  - 9) Loosen four screws (5) to remove the mechanism ass'y (13).
  - 10) Unfasten four connectors on the PC board, F-6505. (See Fig. 6-2)

### B. TACT Knob & PLAY/STOP Knob

- 1) Unlock two stoppers (A & B). (See Fig. 6-4)
- 2) Loosen seven screws (5) to remove the bottom cabinet (16).
- 3) Loosen five screws (5) to remove the PC board, F-6505 (12).
- 4) Loosen one screw (5) to remove a board holder (L) (7).
- 5) Loosen one screw (5) to remove a board holder (S) (6).
- 6) Loosen one screw (5) to remove a PC board, F-6507 (3).
- 7) Loosen two screws (5) to remove a TACT knob (2) and a PLAY/STOP knob (1).

### C. Putting of TACT Knob & PLAY/STOP Knob

- 1) Put a PLAY/STOP knob (1) where it was.
  - 2) Put back a tact knob (2) where it was.
  - 3) Fit the PC board, F-6507 (3) into the holding groove of top cabinet and screw the board. (See Fig. 6-3)
  - 4) Insert a two pins of board holder (L) (7) into holes of PC board, F-6507 at TIME SW and screw the board holder. (See Fig. 6-5)
  - 5) Screw the board holder (S) (6).
  - 6) Insert a remove sensor into hole of PC board, F-6507 (3) and screw the PC board, F-6505 (12).
- Note: Do not put wires between the PC board and a cabinet.
- 7) Put back a bottom cabinet (16) where it was and screw it.
- Note: Insert the PC board, F-6507 (3) into slits of bottom cabinet. (See Fig. 6-3)

Fig. 6-3

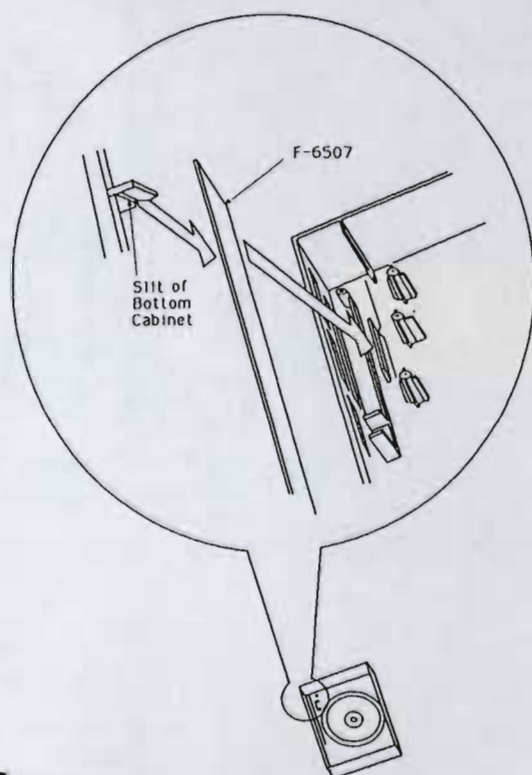

Fig. 6-4

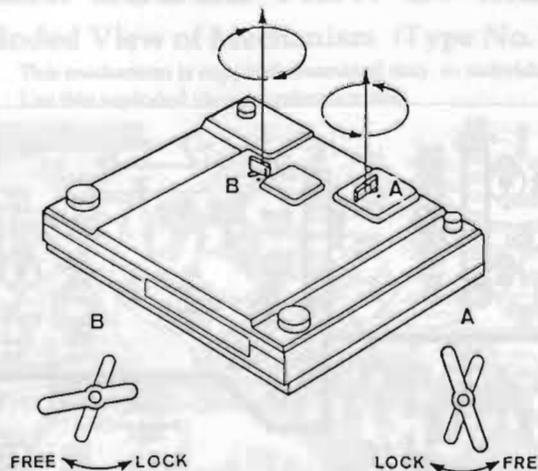

Fig. 6-5

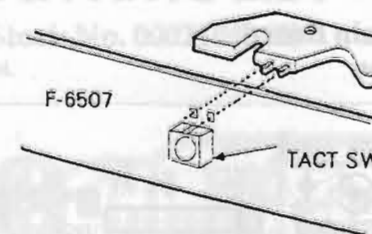

Fig. 6-1

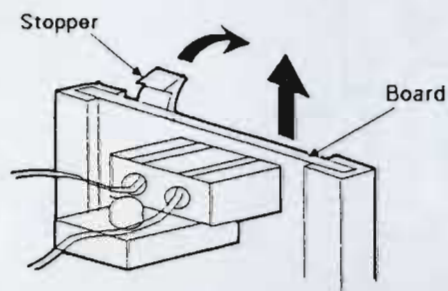
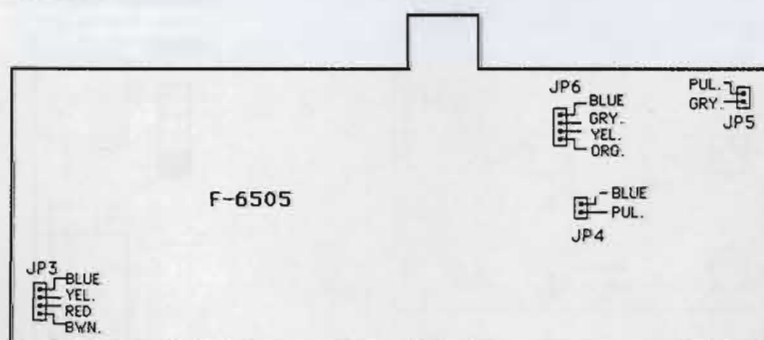

Fig. 6-2



## 7. OTHER PARTS

### Parts List <Top Side>

Parts No.	Stock No.	Description
1	1001104201	Main Cabinet(CD-3100M-UL,CSA,EU)
	1001104510	Main Cabinet(CD-3100M-XX,SS)
	1001104508	Main Cabinet(CD-3100ME-UL,CSA)
	1001104509	Main Cabinet(CD-3100ME-XX,SS)
	1002104511	Main Cabinet(CD-570M-EU)
	1002104534	Main Cabinet(CD-570M-SS)
	1002104533	Main Cabinet(CD-570ME-UL,CSA)
	1001104200	Main Cabinet(CD-570ME-XX)
2	0004104328	Bottom Roller Ass'y
2-1	2004104024	Roller-A
2-2	1004104314	Rubber Ring
3	0004104327	Top Roller Ass'y
3-1	2004104080	Roller-B
3-2	1004104294	Holder
3-3	3004100463	Poly-Washer
3-4	1004104314	Rubber Ring
4	8792300800	Screw,M3x8
5	JS27833300	SANSUI Logo Badge(CD-3100M/ME)
6	1004104310	Front Overlay(CD-3100M/ME)
	1004104311	Front Overlay(CD-570M/ME)
7	1001104206	Turutable
8	0002104292	CD Changer Mechanism Ass'y
9	8791301000	Screw,M3x10
10	2004104307	Rubber-B
11	1001104207	Holder Cover
12	0004104358	Hinge Ass'y(CD-3100M)
	2000000895	Hinge Ass'y(CD-570M/ME)
13	0004104321	Dust Cover Ass'y(CD-3100M)
	0004104322	Dust Cover Ass'y(CD-570M/ME)

### Parts List <Bottom Side>

Parts No.	Stock No.	Description
1	1003104209	Knob,PLAY/STOP
2	1002104210	Knob,TACT
5	8791301000	Screw,M3x10
6	1001104450	Board Holder<S>(CD-3100M/ME)
	1002104533	Board Holder<S>(CD-570M/ME)
7	1001104450	Board Holder<L>(CD-3100M/ME)
	1002104533	Board Holder<L>(CD-570M/ME)
9	1003104208	Knob,POWER
10	8761301012	Screw,M3x10
13	0002104292	CD Changer Mechanism Ass'y
14	4200481450	Power Transformer(UL,CSA)
	or 4200481410	Power Transformer(UL,CSA)
	4200484450	Power Transformer(CD-3100M/ME, CD-570ME-XX,SS)
	or 4200484410	Power Transformer(CD-3100M/ME-XX,SS)
	4200483450	Power Transformer(EU)
16	0004104323	Bottom Cabinet Ass'y(CD-3100M/ME)
	0004104324	Bottom Cabinet Ass'y(CD-3100M/ME)
16-1	1001104205	Bottom Cabinet(CD-3100M/ME)
	1001104204	Bottom Cabinet(CD-570M/ME)
16-2	1004103957	Rubber-A for Leg
16-3	1004104475	Foot Ring Overlay
17	2003104295	LOCK-A
18	2003104296	LOCK-B
21	8761300612	Screw,M3X6
22	8762260808	Screw,M2.5X6
23	2004104497	Cover,POWER Switch
24	4411011601	Slide SW.,voltage selector(CD-570M-SS, CD-570ME-XX,CD-3100M-XX,SS/ME-XX)
	4631112065	Power Supply Cord(CD-3100M-UL,CSA,XX, CD-3100ME,CD-570ME-UL,CSA,XX)
	4632212265	Power Supply Cord(CD-3100M-EU, CD-570M-EU)
	4635212065	Power Supply Cord(CD-3100M-SS, CD-570M-SS)

• Though every Part included in exploded view is numbered in exploded View, Parts Unlisted in parts list are not supplied.



• Exploded View (Top Side)

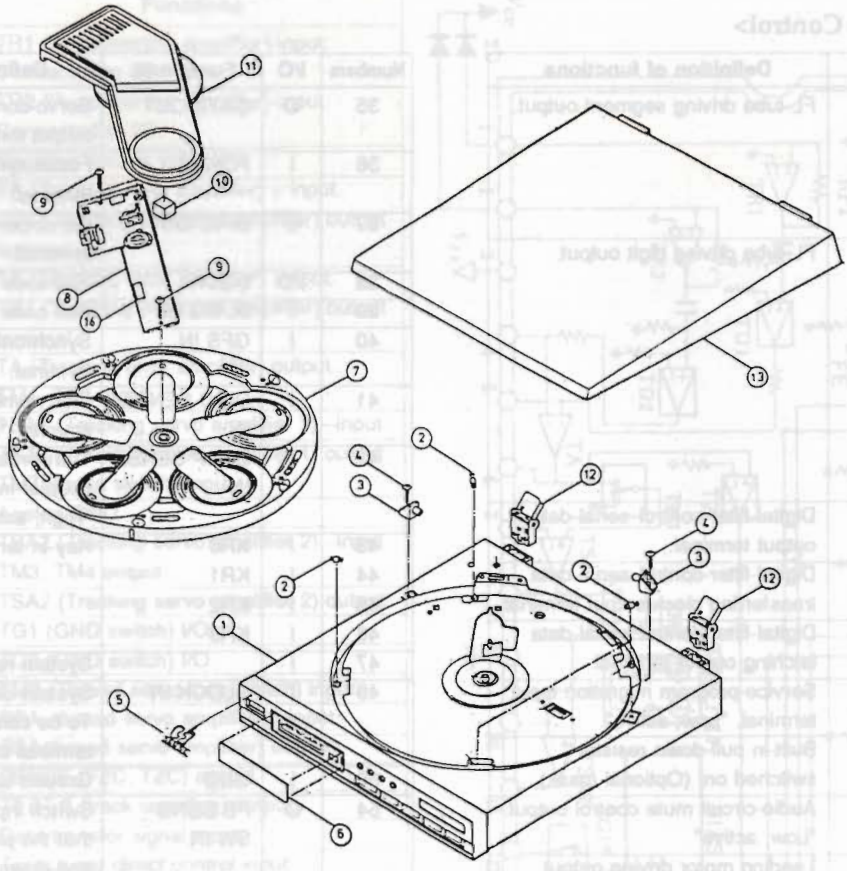

• Exploded View (Bottom Side)

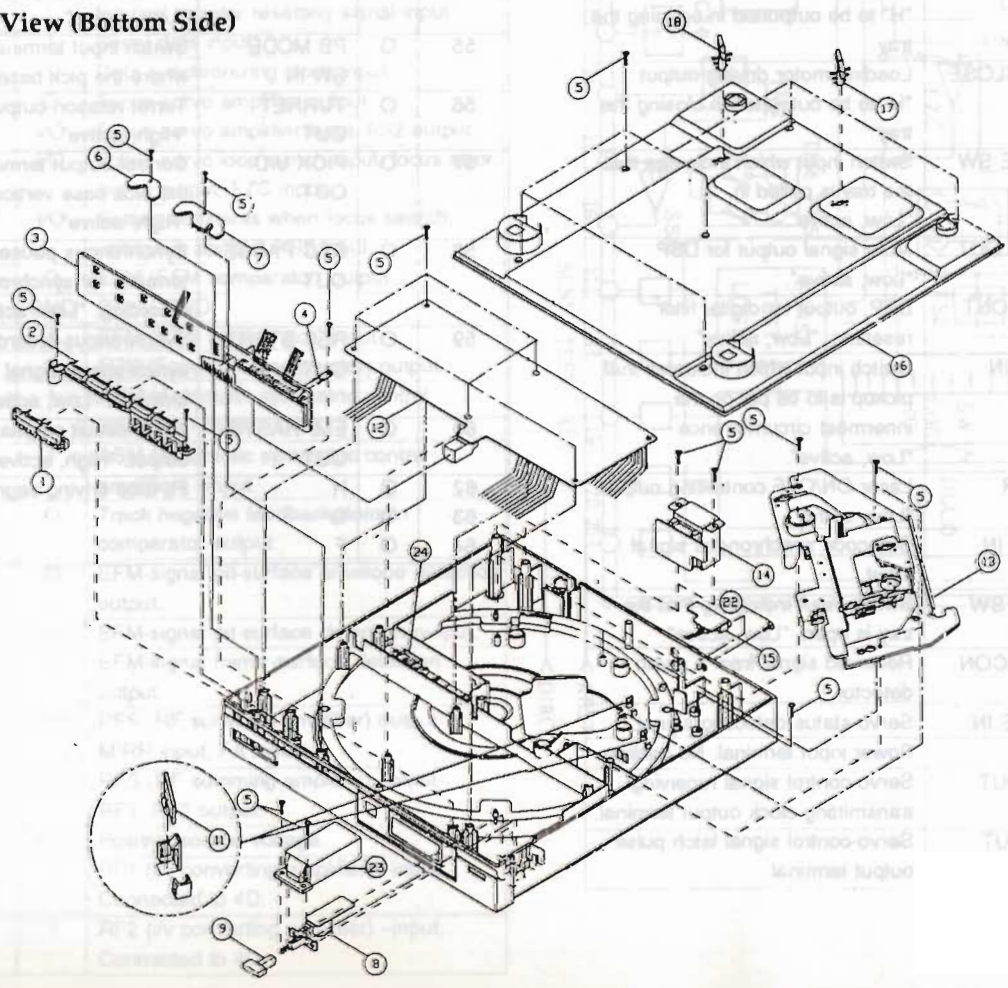



## 8. INTERIOR BLOCK DIAGRAM & TERMINAL FUNCTION OF IC

### • HD4074729S <System Control>

Numbers	I/O	Functions.	Definition of functions
1	O	E	FL-tube driving segment output.
2	O	D	
3	O	C	
4	O	B	
5	O	A	
6	O	G1	FL-tube driving digit output.
7	O	G2	
8	O	G3	
9	O	G4	
10	O	G5	
11	O	G6	
12	O	G7	
13	O	G8	
14	O	G9	
15	O	ATT OUT	Digital-filter-control serial-data output terminal.
16	O	SHIFT OUT	Digital-filter-control serial-data transferring clock output terminal.
17	O	LATCH OUT	Digital-filter-control serial-data latching output terminal.
18	I	TEST	Service-program migration input terminal. "Low, active".
19	I	VDSP	Built-in pull-down resistor switched on. (Optional mask)
20	O	MUTE OUT	Audio-circuit mute control output. "Low, active".
21	O	LDG OPEN OUT	Loading motor driving output. "H" to be outputted in opening the tray.
22	O	LDG CLOSE OUT	Loading motor driving output. "H" to be outputted in closing the tray.
23	I	CLOSE SW IN	Switch input which indicates that the tray is pulled in. "Low, active".
24	O	MUTG OUT	Mute signal output for DSP. "Low, active".
25	O	XRST OUT	DSP, output for digital filter resetting. "Low, active".
26	O	IN SW IN	Switch input which indicates that pickup is to be put on the innermost circumference. "Low, active".
27	O	LASER OUT	Laser ON/OFF controlling output. "Low, active".
28	I	SCOR IN	Sub-code synchronous signal input.
29	I	OPEN SW IN	Switch input indicating that the tray is open. "Low, active".
30	I	REMOCON IN	Received signal from a photo detector.
31	I	SENSE IN	Servo-status detecting signal.
32			Power input terminal. No backup.
33	O	CLK OUT	Servo-control signal receiving/transmitting clock output terminal.
34	O	XLT OUT	Servo-control signal latch pulse output terminal.

Numbers	I/O	Functions.	Definition of functions
35	O	DATA OUT	Servo-control signal serial data output terminal.
36	I	FOK IN	Focus synchronous signal input terminal.
37	O	DIRC OUT	Servo-control signal output terminal.
38	I/O	SQCK	Sub-code reading clock.
39	I	SUBQ IN	Sub-code data input terminal.
40	I	GFS IN	Synchronous rotation signal input terminal.
41	I	DISC SENSE IN	Disc number detection photo coupler. "High, active".
42	I	STOP SENSE IN	Turret-rotation control photo coupler input terminal. "High, active".
43	I	KR0	Key-in terminal.
44	I	KR1	
45	I	KR2	
46	I	KR3	
47	I		System resetting input terminal.
49	I	CLOCK IN	System clock input terminal. To be connected to the C4N terminal of the DSP (CXD1125Q).
50	I	GND	Ground terminal.
54	O	PB SENS SW IN	Switch input terminal indicating that the pick base is at the up-and-down stop position. "Low, active".
55	O	PB MODE SW IN	Switch input terminal indicating where the pick base is.
56	O	TURRET OUT	Turret rotation output terminal "High, active".
57	O	PICK U/D OUT	Control output terminal moving the pick base vertically. "High, active".
58	O	REC PAUSE OUT	Synchronous pause signal output terminal for synchronous recording. "Low, active".
59	O	REC START OUT	Synchronous-recording start signal output terminal. "Low, active".
60	O	EMPHASYS OUT	Audio circuit emphasis control output. "High, active".
62	O	H	FL tube driving segment output.
63	O	G	
64	O	F	

### • HA12095NT <RF Amp.>

Pin No.	Symbols	I/O	Functions
1	TR1	I	TR1 (i/v converting amplifier)-input. Connected to 2D.
2	TR2	I	TR2 (i/v converting amplifier)-input. Connected to 2D.
3	VEE	VEE	Negative source voltage.
4	TA+	I/O	TA (Tracking error amplifier) + input. TD2 (Tracking detection amplifier) output terminal.
5	TA-	I/O	TA (Tracking error amplifier) -input. TD1 (Tracking detection amplifier) output terminal.
6	TE	I/O	TA (Tracking error amplifier) output. TM1, TZC input.
7	T1-	I	TSA1 (Tracking servo amplifier 1) -input.
8	T1O	I/O	TSA1 (Tracking servo amplifier 1) output. TM7 (brake switch) input.
9	AG	GND	Analog GND.
10	T2-	I/O	TSA2 (Tracking servo amplifier 2) -input. TM3, TM4 output.
11	T2O	O	TSA2 (Tracking servo amplifier 2) output.
12	TG1	I/O	TG1 (GND switch) I/O.
13	TG2	I/O	TG2 (GND switch) I/O.
14	TM2	I	TM2 (Thread servo loop switch) input.
15	SS-	I	SSA (thread servo amplifier) -input.
16	SSO	O	SSA (thread servo amplifier) output.
17	SEN	O	SENSE (FZC, TZC) output.
18	TES	O	TEST 8 (track counting) output.
19	XLT	I	Data transfer signal input.
20	DIR	I	Track jump direct control input.
21	XRS	I	Internal register resetting signal input.
22	DAT	I	Serial data input.
23	CLK	I	Data synchronizing clock input.
24	FSO	O	Focus servo amplifier output.
25	FS-	I/O	Focus servo amplifier input. FS2 output.
26	FE	I/O	Focus servo loop switch input, focus error signal output, FZC input.
27	EUD	I/O	Setting constants when focus search. voltage is applied. FS2 input.
28	EFO	O	EFM (EFM comparator) output.
29	DG	GND	Digital GND.
30	EF1	I	EFM (EFM comparator) input.
31	FOK	O	FOK (Focus OK comparator) output.
32	Vdd	I	ASM (Automatic symmetric control amplifier) -input.
33	DSL	I	ASM (Automatic symmetric control amplifier) +input.
34	TOK	O	Track negative feedback domain comparator output.
35	ENV	O	EFM-signal pit-surface envelope detection output.
36	PIT	O	EFM-signal pit-surface detection output.
37	MIR	O	EFM-signal mirror-surface detection output.
38	RFS	I/O	RFS (RF summing amplifier) output. MIRR input, FA input.
39	RF-	I/O	RFS (RF summing amplifier) -input. RF1, RF2 output.
40	Vcc	Vcc	Positive source voltage.
41	RF1	I	RF1 (i/v converting amplifier) -input. Connected to 4D.
42	RF2	I	RF2 (i/v converting amplifier) -input. Connected to 4D.

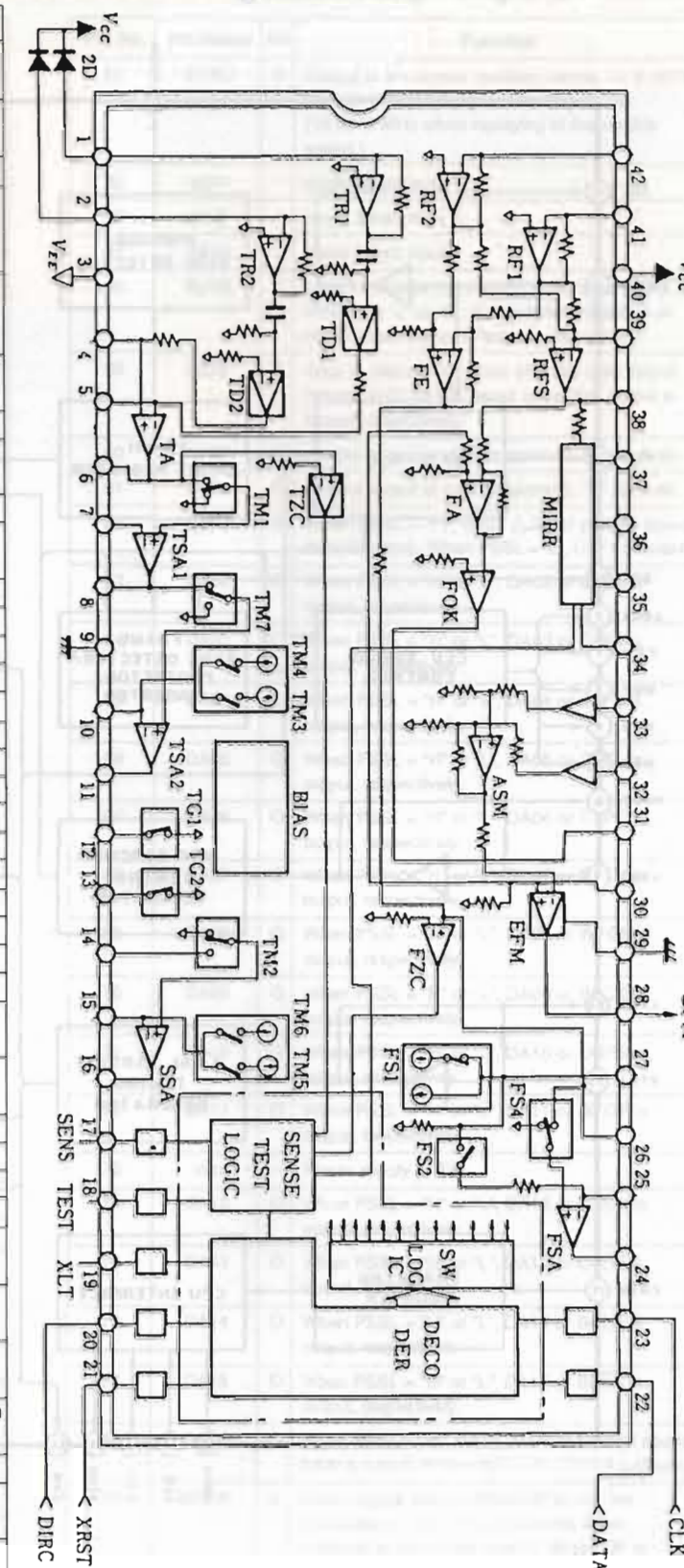



• CXD1167Q (Digital Signal Processing)

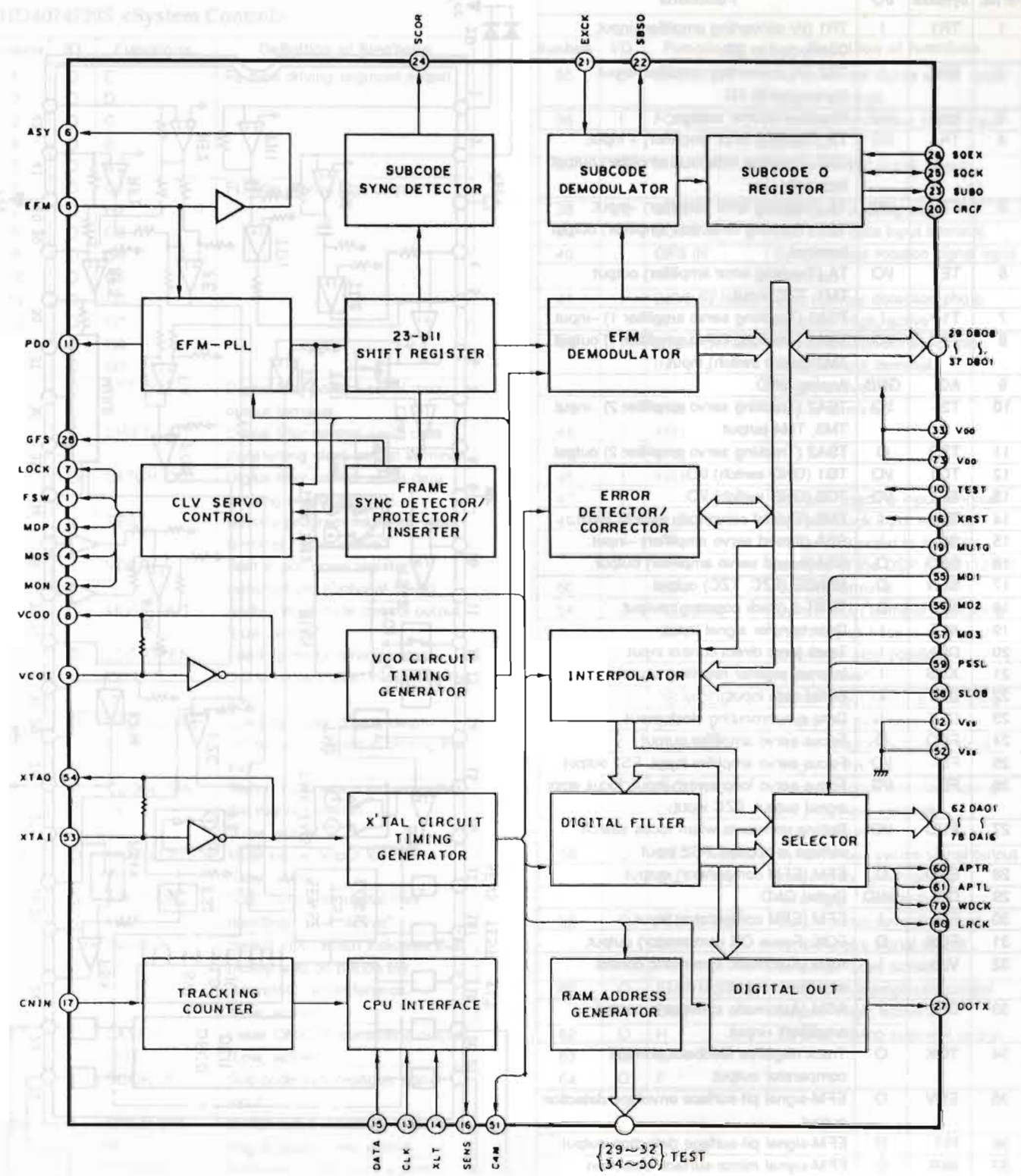

Terminal Function <CXD1167Q>

Pin No.	Pin Name	I/O	Function
1	FSW	O	Output to change the time constant of the output filter for the spindle motor
2	MON	O	Output to control ON/OFF of the spindle motor
3	MDP	O	Output to drive the spindle motor. For rough control in the CLV-S mode and phase control in the CLV-P mode.
4	MDS	O	Output to drive the spindle motor. For speed control in the CLV-P mode.
5	EFM	I	EFM signal input from the RF amplifier
6	ASY	O	Output to control the slice level of the EFM signal.
7	LOCK	O	Issues "H" when the GFS signal is "H" by sampling with WFCK/16. If it is "L" consecutively 8 times, "L" is output.
8	VCOO	O	VCO output. f = 8.6436 MHz when locked to the EFM signal. (17.2872 MHz when replayed at the double speed.)
9	VCOI	I	VCO input
10	TEST	I	(0V)
11	PDO	O	Output of phase comparison between the EFM signal and VCO/2
12	VSS	—	GND (0V)
13	CLK	I	Input of clock from CPU to transfer serial data. Data is latched at the rise edge of the clock.
14	XLT	I	Latch input from CPU. The data (serial data from CPU) of the 8 bit shift register is latched to each register.
15	DATA	I	Serial data input from CPU
16	XRST	I	System reset input. "L" activates resetting.
17	CNIN	I	Input of tracking pulse
18	SENS	O	Issues internal status according to the address
19	MUTG	I	Muting input. When ATTM of the internal register A is "L", MUTG is "L", i.e. normal status. "H" activates no-sound status.
20	CRCF	O	Issues the output of CRC check result for the subcode Q.
21	EXCK	I	Clock input for serial output of subcode
22	SBSO	O	Serial output of subcode
23	SUBQ	O	Output of subcode Q
24	SCOR	O	Output of subcode sync S0 + S1
25	SQCK	I/O	Clock to read subcode Q.
26	SQEX	I	SQCK selection input (see the CPU interface for more detail.)
27	DOTX	O	Digital output (WFCK is output when DO is OFF.)
28	GFS	O	Output to indicate locked status of frame sync
29-33	TEST	I	Fix to "H" or "L". Don't make it open.
33	VDD	—	Power supply (+ 5V)
34-40	TEST	I	Fix to "H" or "L". Don't make it open.
41-50	TEST	I	Fix to "H" or "L". Don't make it open.
51	C4M	O	Frequency division output of the crystal oscillator. f = 4.2336 MHz (8.4672 MHz when replayed at the double speed.)
52	VSS	—	GND (0V)
53	XTAI	I	Input to the crystal oscillator circuit. f = 8.4672 MHz or 16.9344 MHz by selecting mode. (16.9344 MHz when replayed at the double speed.)

Pin No.	Pin Name	I/O	Function
54	XTAO	O	Output to the crystal oscillator circuit. f = 8.4672 MHz or 16.9344 MHz by selecting mode. (16.9344 MHz when replayed at the double speed.)
55	MD1	I	Mode select input 1
56	MD2	I	Mode select input 2
57	MD3	I	Mode select input 3
58	SLOB	I	Input to change the code of audio data output. When it is "L" or "H", 2's compliment output or offset binary output is issued, respectively.
59	PSSL	I	Input to change the mode of audio data output. When it is "L" or "H", serial or parallel output is issued, respectively.
60	APTR	O	Control output to correct aperture. "H" for R-ch.
61	APTL	O	Control output to correct aperture. "H" for L-ch.
62	DA01	O	When PSSL = "H", DA01 (LSB of parallel sound data) is output. When PSSL = "L", C1F1 is output.
63	DA02	O	When PSSL = "H" or "L", DA02 or C1F2 is output, respectively.
64	DA03	O	When PSSL = "H" or "L", DA03 or C2F1 is output, respectively.
65	DA04	O	When PSSL = "H" or "L", DA04 or C2F2 is output, respectively.
66	DA05	O	When PSSL = "H" or "L", DA05 or C2FL is output, respectively.
67	DA06	O	When PSSL = "H" or "L", DA06 or C2PO is output, respectively.
68	DA07	O	When PSSL = "H" or "L", DA07 or RFCK is output, respectively.
69	DA08	O	When PSSL = "H" or "L", DA08 or WFCK is output, respectively.
70	DA09	O	When PSSL = "H" or "L", DA09 or PLCK is output, respectively.
71	DA10	O	When PSSL = "H" or "L", DA10 or UGFS is output, respectively.
72	DA11	O	When PSSL = "H" or "L", DA11 or GTOP is output, respectively.
73	VDD	—	Power supply (+ 5V)
74	DA12	O	When PSSL = "H" or "L", DA12 or RAOV is output, respectively.
75	DA13	O	When PSSL = "H" or "L", DA13 or C4LR is output, respectively.
76	DA14	O	When PSSL = "H" or "L", DA14 or BCLK is output, respectively.
77	DA15	O	When PSSL = "H" or "L", DA15 or BCLK is output, respectively.
78	DA16	O	When PSSL = "H", DA16 (MSB of parallel sound data) is output. When PSSL = "L", DATA is output.
79	WDCCK	O	Strobe signal output. When DF is ON, the frequency is 176.4 kHz (352.8 kHz when replayed at the double speed). When DF is OFF, it is 88.2 kHz (176.4 kHz when replayed at the double speed).
80	LRCK	O	Strobe signal output. When DF is ON, the frequency is 88.2 kHz (176.4 kHz when replayed at the double speed). When DF is OFF, it is 44.1 kHz (88.2 kHz when replayed at the double speed).



• PD0034 (Digital Filter)

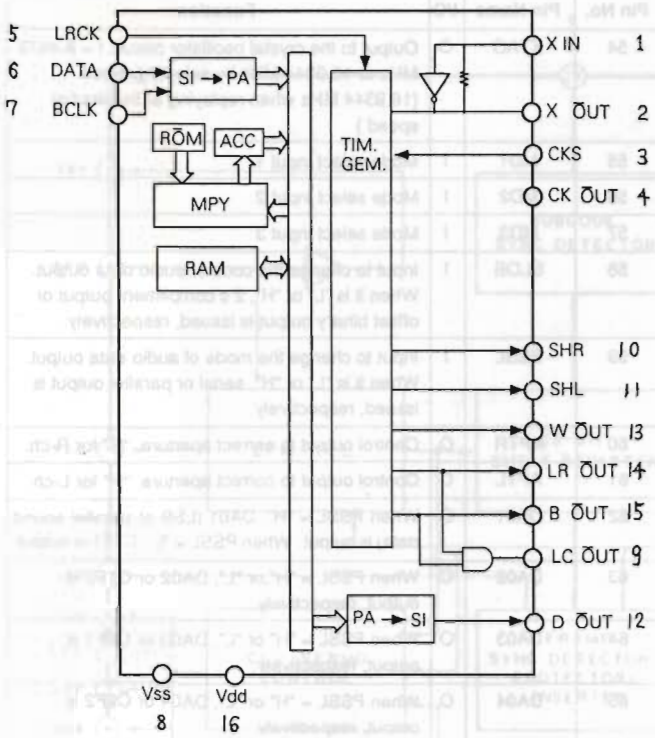

•  $\mu$ PD6376CX (D/A Converter)

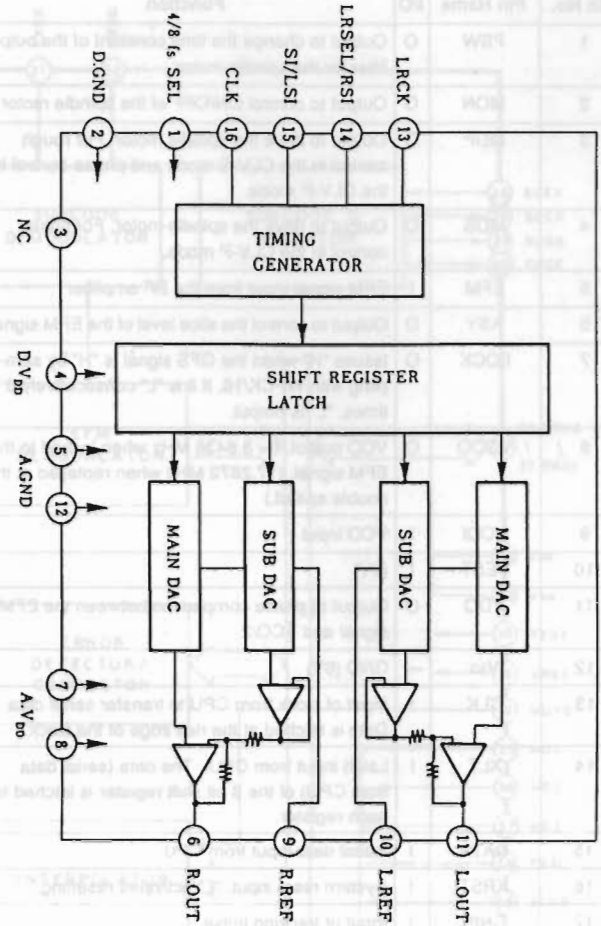

• LB1641 (Motor Driver)

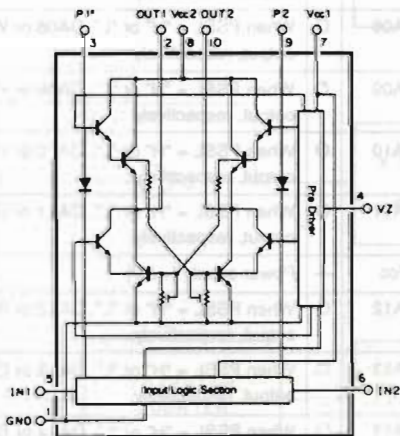

• M5218L/M5238L/NJM4558L/NJM2082L (OP Amp.)

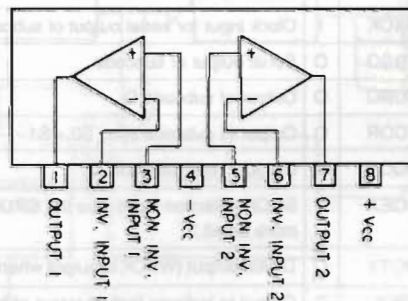



# 9. SCHEMATIC DIAGRAM

• Design and specifications subject to change without notice for improvement.  
• La présentation et les spécifications sont susceptibles d'être modifiées sans préavis par suites d'améliorations éventuelles.  
• Änderungen, die dem technischen Fortschritt dienen, bleiben vorbehalten.

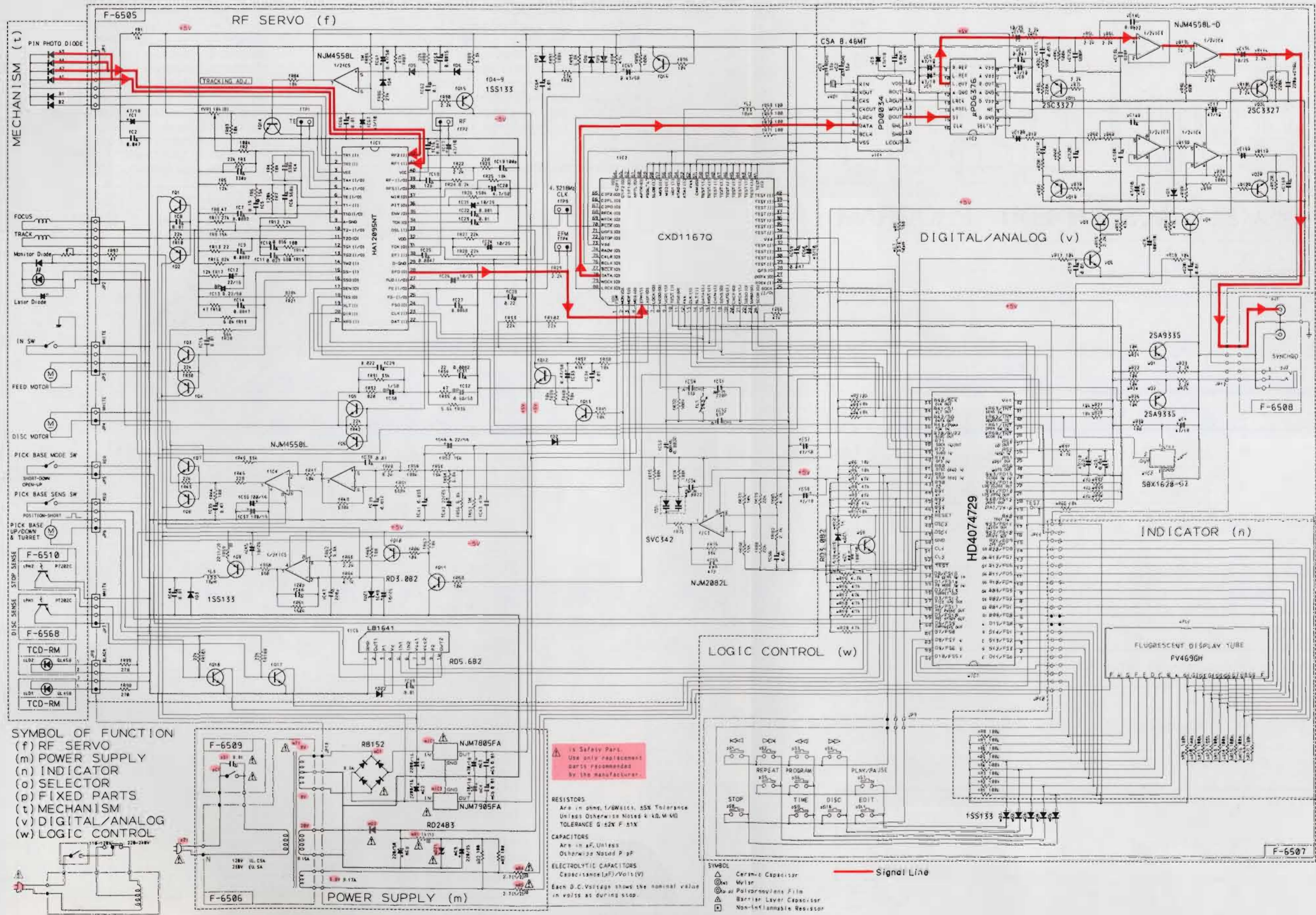

**SYMBOL OF FUNCTION**  
 (f) RF SERVO  
 (m) POWER SUPPLY  
 (n) INDICATOR  
 (o) SELECTOR  
 (p) FIXED PARTS  
 (t) MECHANISM  
 (v) DIGITAL/ANALOG  
 (w) LOGIC CONTROL

**is Safety Parts.**  
 Use only replacement parts recommended by the manufacturer.

**RESISTORS**  
 Are in ohms, 1/8Watts, 5% Tolerance  
 Unless Otherwise Noted k, M, Ω  
 TOLERANCE G ±2% F ±1%

**CAPACITORS**  
 Are in μF, Unless  
 Otherwise Noted p pF

**ELECTROLYTIC CAPACITORS**  
 Capacitance (μF)/Voltage (V)  
 Each D.C. Voltage shows the nominal value  
 in volts at during stop.

**SYMBOL**  
 △ Ceramic Capacitor  
 ⊗ Mylar  
 ⊕ as Polypropylene Film  
 ▽ Barrier Layer Capacitor  
 □ Non-Inflammable Resistor

**Signal Line**

- 1 11E2 HA12095NT  
HD407429S  
PD0034  
UPD6376CX
- 2 1S5133 NJM7805FA
- 3 RB-152 NJM7905FA
- 4 SVC342 CXD1167Q
- 5 RD24ES 2SA933S  
RD3.0ES 2SC2001  
RD6.8ES  
RD5.6ES
- NJM2082L 2SA933S  
NJM4558LD 2SC1740S
- LB1641 2SC3327



# 10. PIN ASSIGNMENT OF FL DISPLAY, FV469GH

## • Grid Assignment

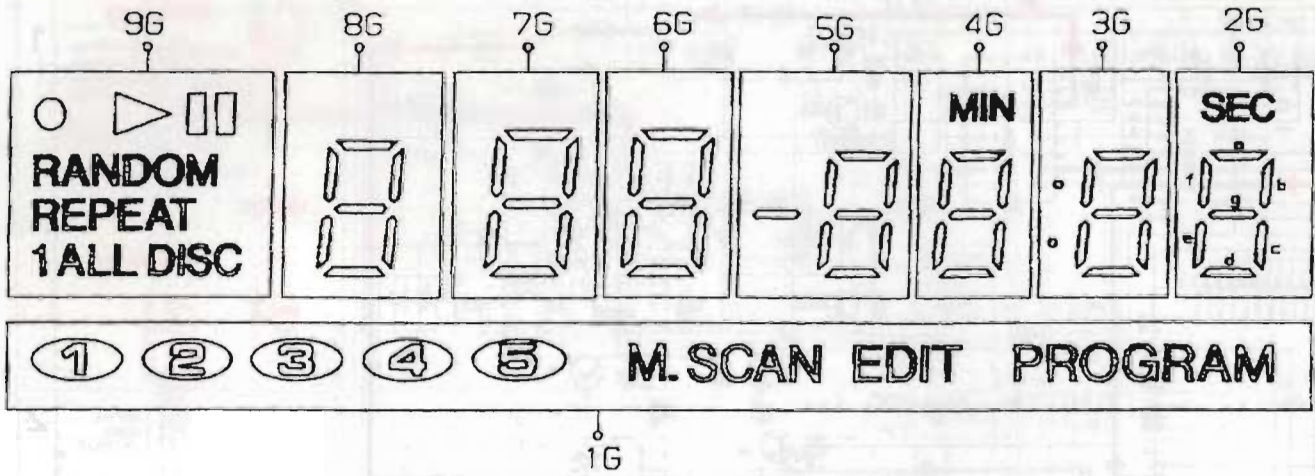

## • Anode Connection

	9G	8G	7G	6G	5G	4G	3G	2G	1G
P1	▯▯	f	f	f	f	f	f	f	PROGRAM
P2	ALL	c	c	c	c	c	c	c	EDIT
P3	1	d	d	d	d	d	d	d	M.SCAN
P4	DISC	e	e	e	e	e	e	e	⑤
P5	REPEAT	g	g	g	g	g	g	g	④
P6	RANDOM	b	b	b	b	b	b	b	③
P7	▶	a	a	a	a	a	a	a	②
P8	○	▯	▯	▯	▯	MIN	○	SEC	①

## • Pin Assignment

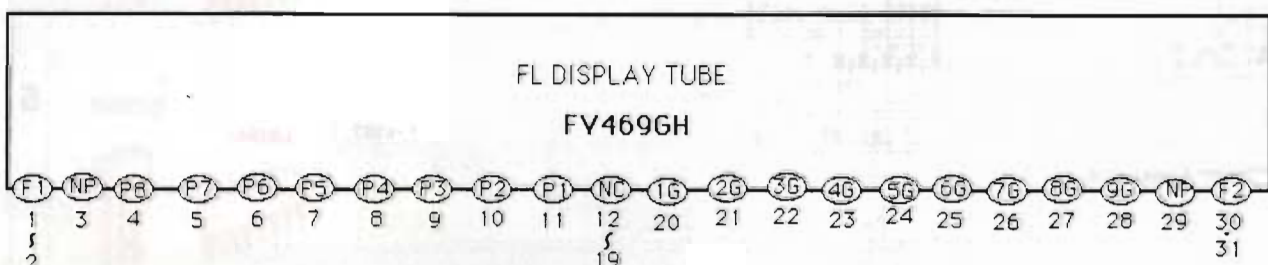



## 11. ACCESSORY LIST

Parts No.	Stock No.	Description
	9004104359	Operating Instruction(E.F.S)
	9004104357	Operating Instruction(H.G.I.Sw)
	571C900001	Remote Controller Unit (CD-3100M,570M)
	4500100313	Jack,synchro(CD-3100M/ME)
	4510130301	Synchro Cord(CD-3100M)
	5620708008	RCA Pin Plug Cord
△	4570206108	Plug,type changer of AC plug (XX)

**Note:**

**E · F · S:** English · French and Spanish Version

**H · G · I · Sw:** Hollands · German · Italian and Swedish Version

## 12. PACKING LIST

Parts No.	Stock No.	Description
1	9004104548	Poly Bag(CD-3100M/ME)
	9905006546	Poly Bag(CD-570M/ME)
2	9001104315	Styrofoam Packing<R>(CD-3100M)
	9001104366	Styrofoam Packing<R>(CD-3100ME)
	9001104316	Styrofoam Packing<R>(CD-570M/ME)
3	9001104317	Styrofoam Packing<L>(CD-3100M)
	9001104367	Styrofoam Packing<L>(CD-3100ME)
	9001104318	Styrofoam Packing<L>(CD-570M/ME)
4	9002104319	Carton Case(CD-3100M)
	9002104342	Carton Case(CD-3100ME)
	9002104320	Carton Case(CD-570M)

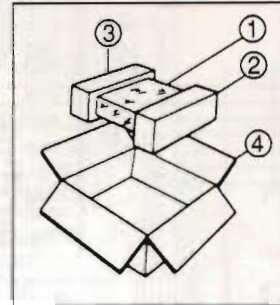

SANSUI ELECTRIC CO., LTD.:

SANSUI USA INC.:

SANSUI DEUTSCHLAND GMBH:

山水電気株式会社

New River Building, 10-14, Shinkawa 1-chome, Chuo-ku Tokyo 104, Japan  
 PHONE: (03)5566-1024 FAX: (03)5566-1027 (International Division)  
 1250 Valley Brook Ave. Lyndhurst, N. J. 07071 U. S. A.  
 17150 South Margay Ave. Carson, California 90746 U. S. A.  
 Paul Ehrlich Strasse 8, 6074 Rödermark 2, West Germany

東京都中央区新川 1-10-14 (〒104)

(SM2-187)

Printed in Japan (1990.10.P)

< Stock No. 36555100 >