

SERVICE MANUAL

STEREO CASSETTE DECK

SANSUI D-1000W

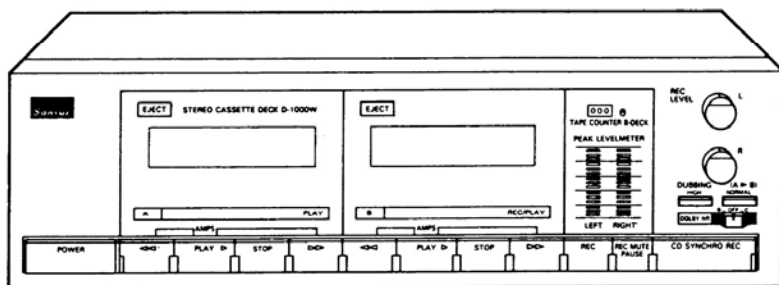

CAUTION

1. Parts identified by the \triangle symbol on the schematic diagram and the parts list are critical for safety. Use only replacement parts that have critical characteristics recommended by the manufacturer.
2. Make leakage-current or resistance measurements to determine that exposed parts are acceptably insulated from the supply circuit before returning the appliance to the customer.

•SPECIFICATIONS

Track format	4-track/2-channel system
Tape speed	4.8 cm/sec
Heads	
Rec/play head.....	HIGH-Bs hard permalloy
Play head	HIGH-Bs hard permalloy
Erase head.....	Double-gap HIGH-Bs ferrite
Motor	
	Electronically controlled DC motor \times 2
	Reels: DC Motor \times 2
Wow/flutter	0.09% max (WRMS)
Fast forwarding (rewinding) time	
	Approx. 90 sec. (for C-60 tape)
Frequency response (—20 VU recording/playback)	
Normal tape (LH)	20 to 15,000 Hz (30 to 14,000 Hz \pm 3 dB)
Chrome tape	20 to 16,000 Hz (30 to 15,000 Hz \pm 3 dB)
Metal tape	20 to 17,000 Hz (30 to 16,000 Hz \pm 3 dB)
Signal-to-noise ratio (recording/playback with metal tape)	
DOLBY NR OFF	Better than 54 dB
DOLBY-B NR ON	Better than 64 dB
DOLBY-C NR ON	Better than 72 dB
Erase rate (metal tape) .	More than 70 dB at 1 kHz
Recording bias frequency	105 kHz
Input sensitivity/Impedance	
LINE IN (REC).....	70 mV/47 kohms
Power requirements	
	110/120/220/240V
	50/60 Hz
	For U.S.A. and Canada 120V (60 Hz)
Power consumption	24 watts
Dimensions	
	430 mm (16-15/16") W
	127 mm (5") H
	228 mm (8-31/32") D
Weight	
	4.4 kg (9.68 lbs) net
	5.2 kg (11.44 lbs) packed

- * Design and specifications subject to changes without notice for improvements.
- * Noise reduction system manufactured under license from Dolby Laboratories Licensing Corporation. "Dolby" and the double D symbol are trade marks of Dolby Laboratories Licensing Corporation.

Sansui

SANSUI ELECTRIC CO., LTD.

NOTE

1. The symbols, UL, CSA, SA, BS, UK, EU, AS, SEV, SS, XX <EXPORT> and XX-V <EXPORT(V)> on the parts list and the schematic diagram mean followings respectively.

UL..... Manufactured for U.S.A market.
(Underwriters Laboratories approved model.)
 CSA Manufactured for Canadian market.
 SA..... Manufactured for South African market.
 BS, UK..... Manufactured for United Kingdom market.
 EU Manufactured for European market.
 AS..... Manufactured for Australian market.
 SEV Manufactured for Swiss market.
 SS..... Manufactured for Saudi Arabia market.
 XX <EXPORT> Standard Version with Inner Voltage Selector.
 XX-V <EXPORT(V)> .. Standard Version with Outer Voltage Selector.
 NON MARK Common Parts.

2. Some printed circuit boards are not supplied assembled. To separate these in this service manual, the stock numbers are not indicated for these boards. However, stock numbers for individual parts are indicated.
3. Since some capacitors and resistors are omitted from parts lists in this service manual, refer to the Common Parts List for capacitors and resistors, which was issued on June 1987.
4. Abbreviations in this service manual are as follows.

•Abbreviations List

C.R.	: Carbon Resistor	E.B.L.	: Low Leak Bi-Polar Electrolytic Capacitor
S.R.	: Solid Resistor	Ta.C.	: Tantalum Capacitor
Ce.R.	: Cement Resistor	F.C.	: Film Capacitor
M.R.	: Metal Film Resistor	M.P.	: Metalized Paper Capacitor
F.R.	: Fusing Resistor	P.C.	: Polystyrene Capacitor
N.I.R.	: Non-Inflammable Resistor	G.C.	: Gimmic Capacitor
A.R.	: Array Resistor	A.C.	: Array Capacitor
C.C.	: Ceramic Capacitor	V.R.	: Variable Resistor
C.T.	: Ceramic Capacitor, Temperature Compensation	S.V.R.	: Semi Variable Resistor
E.C.	: Electrolytic Capacitor	SW.	: Switch
E.L.	: Low Leak Electrolytic Capacitor	Chip R.	: Chip Resistor
E.B.	: Bi-Polar Electrolytic Capacitor	Chip C.	: Chip Capacitor

1-5. F-5761 A-Side Play Amp. Board

Component Side

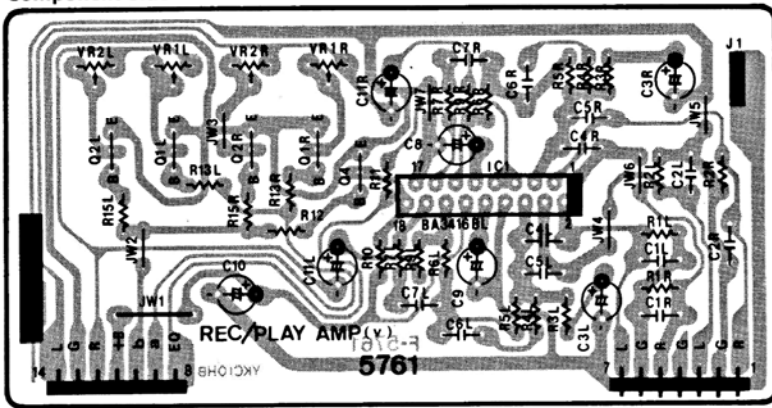

1-8. F-5762 A-Side Play Amp.

Component Side

Dubbing Board

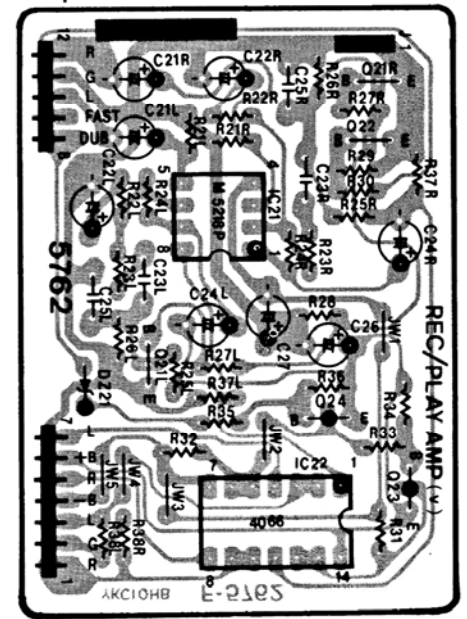

1-6. F-5763 B-Side Rec/Play Amp. Board

Component Side

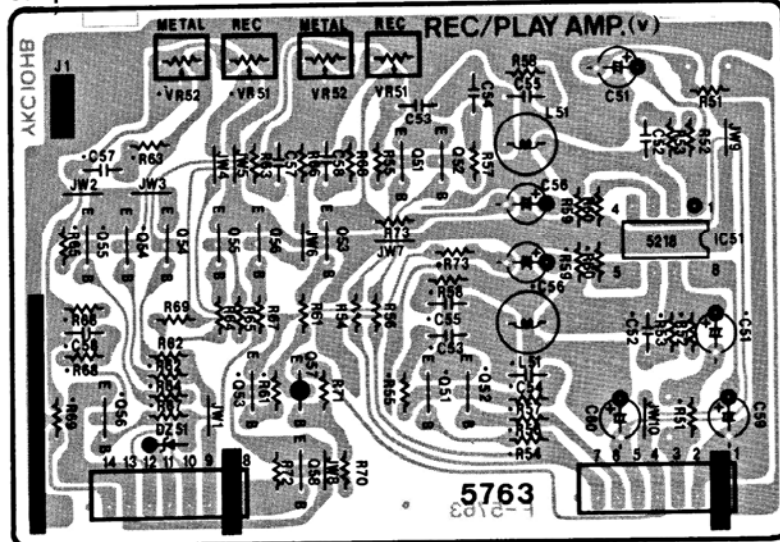

•Note: On this circuit board, the left channel is specified by “●” mark on top of the parts number.

1-7. F-5735 Speed Control Board

Component Side

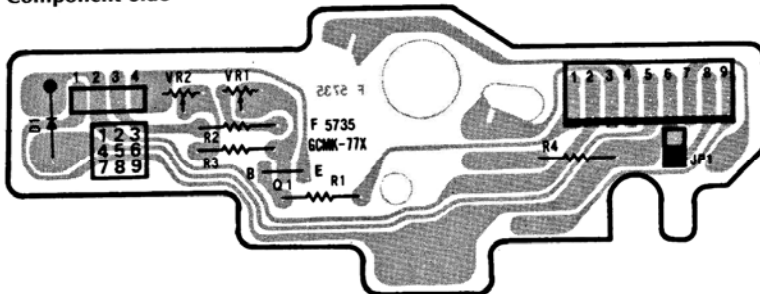

1-9. F-5734 Wiring Board

Component Side

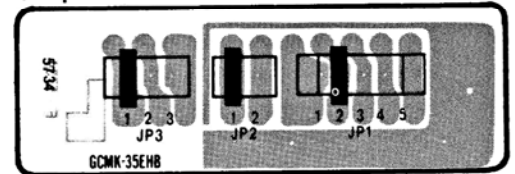

1-10. F-5757 Power Indicator Board

Component Side

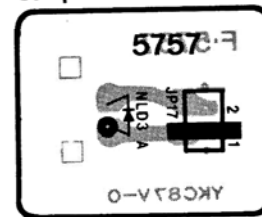

1-11. F-5736 Sensor SW. Board

Component Side

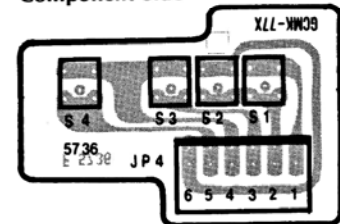

1-12. F-5754 Logic Control & Rec/Play Amp. Board

Component Side

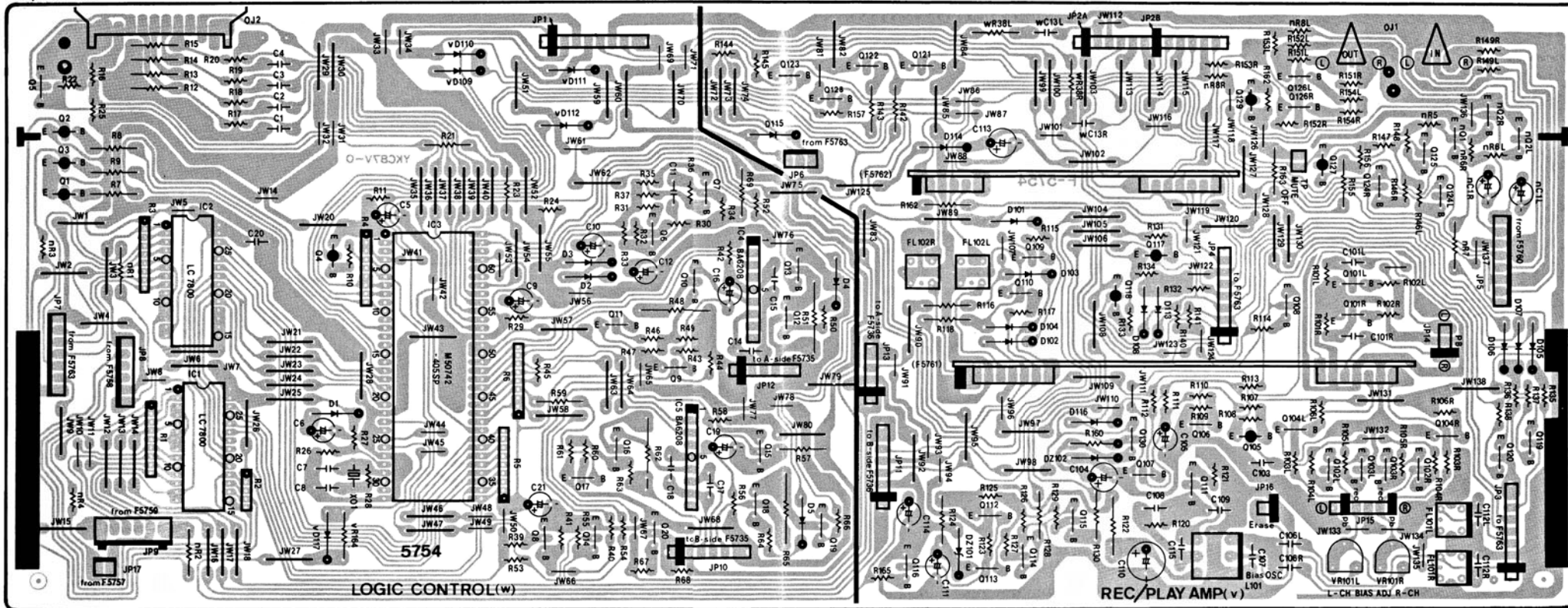

1-13. F-5755 Dolby Noise Reduction & Power Supply Board

Component Side

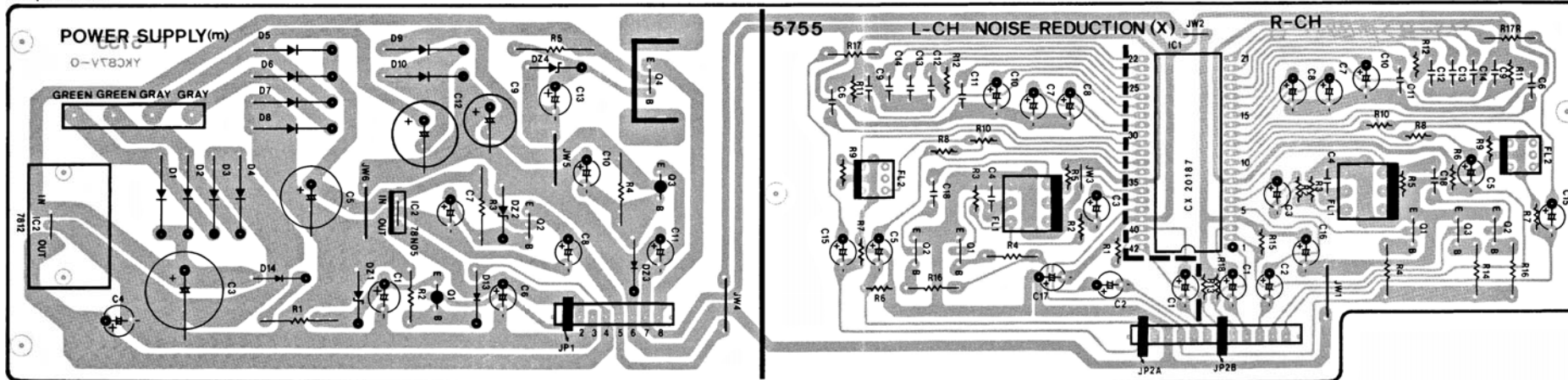

2. PARTS LIST OF BOARD

2-1. F-5754 Logic Control & Rec/Play Amp. Board (Stock No. 01044201)

Parts No.	Stock No.	Description	Parts No.	Stock No.	Description
•Transistor			vD102	03117600	1S2473T77
nQ1	46367101	2SC2603	or 46086000	1S1588TP-3	
	or 48058801	2SC1740S	vD103	03117600	1S2473T77
nQ2	46367101	2SC2603	or 46086000	1S1588TP-3	
	or 48058801	2SC1740S	vD104	03117600	1S2473T77
oJ2	48313900	ST Socket (10 Pin) SYSTEM CONTROL	or 46086000	1S1588TP-3	
oJ1	48845900	4P Terminal, LINE IN. OUT	vD105	03117600	1S2473T77
	or 83004300	4P Terminal, LINE IN. OUT	or 46086000	1S1588TP-3	
•Transistor			vD106	03117600	1S2473T77
vQ101	46367101	2SC2603	or 46086000	1S1588TP-3	
	or 48058801	2SC1740S	vD107	03117600	1S2473T77
vQ102	46581701	2SC1845	or 46086000	1S1588TP-3	
vQ103	46581701	2SC1845	vD108	03117600	1S2473T77
vQ104	46359801	2SC2001	or 46086000	1S1588TP-3	
	or 48055901	2SD1468S	vD109	03117600	1S2473T77
vQ105	46581601	2SA992	or 46086000	1S1588TP-3	
vQ106	46367101	2SC2603	vD110	03117600	1S2473T77
	or 48058801	2SC1740S	or 46086000	1S1588TP-3	
vQ107	46367101	2SC2603	vD111	03117600	1S2473T77
	or 48058801	2SC1740S	or 46086000	1S1588TP-3	
vQ108	46367101	2SC2603	vD112	03117600	1S2473T77
	or 48058801	2SC1740S	or 46086000	1S1588TP-3	
vQ109	46367101	2SC2603	vD113	03117600	1S2473T77
	or 48058801	2SC1740S	or 46086000	1S1588TP-3	
vQ110	46367101	2SC2603	vD114	03117600	1S2473T77
	or 48058801	2SC1740S	or 46086000	1S1588TP-3	
vQ111	46614101	2SC3243	vD115	03117600	1S2473T77
vQ112	46614101	2SC3243	or 46086000	1S1588TP-3	
	or 48000901	2SC2060	vD116	03117600	1S2473T77
vQ113	46367101	2SC2603	or 46086000	1S1588TP-3	
	or 48058801	2SC1740S	vD117	03117600	1S2473T77
vQ114	46367101	2SC2603	or 46086000	1S1588TP-3	
	or 48058801	2SC1740S	vD118	03117600	1S2473T77
vQ115	46367101	2SC2603	or 46086000	1S1588TP-3	
	or 48058801	2SC1740S	•Zener Diode		
vQ116	46367101	2SC2603	vDZ101	46108800	05Z2.4-X
	or 48058801	2SC1740S	vDZ102	46112800	05Z8.2-Z
vQ117	46367001	2SA1115	vFL101	48848300	Trap Filter (105kHz)
	or 48058801	2SA933S	or 83008400	Trap Filter (105kHz)	
vQ118	46367001	2SA1115	vFL102	48366300	Trap Filter
	or 48058801	2SA933S	vL101	48525100	OSC Coil OF-10
vQ119	46367101	2SC2603	vVR101	46634900	100kΩ S.V.R., Bias adj.
	or 48058801	2SC1740S	or 83009500	100kΩ S.V.R., Bias adj.	
vQ120	46367101	2SC2603	•Transistor		
	or 48058801	2SC1740S	wQ1	46367001	2SA1115
vQ121	46367101	2SC2603	or 48058801	2SA933S	
	or 48058801	2SC1740S	wQ2	46367001	2SA1115
vQ122	46367101	2SC2603	or 48058801	2SA933S	
	or 48058801	2SC1740S	wQ3	46367001	2SA1115
vQ123	46367101	2SC2603	or 48058801	2SA933S	
	or 48058801	2SC1740S	wQ4	46367001	2SA1115
vQ124	46367101	2SC2603	or 48058801	2SA933S	
	or 48058801	2SC1740S	wQ5	46367101	2SC2603
vQ125	46367101	2SC2603	or 48058801	2SC1740S	
	or 48058801	2SC1740S	wQ6	46367101	2SC2603
vQ126	46367101	2SC2603	or 48058801	2SC1740S	
	or 48058801	2SC1740S	wQ7	46367101	2SC2603
vQ127	46367001	2SA1115	or 48058801	2SC1740S	
	or 48058801	2SA933S	wQ8	46367101	2SC2603
vQ128	46367101	2SC2603	or 48058801	2SC1740S	
	or 48058801	2SC1740S	wQ9	46367101	2SC2603
vQ129	46367001	2SA1115	or 48058801	2SC1740S	
	or 48058801	2SA933S	wQ10	46614101	2SC3243
vQ130	46367101	2SC2603	or 48000901	2SC2060	
	or 48058801	2SC1740S	wQ11	46367101	2SC2603
•Diode			or 46086000	1S1588TP-3	
vD101	03117600	1S2473T77			
	or 46086000	1S1588TP-3			

2-2. F-5755 Dolby Noise Reduction & Power Supply Board (Stock No. 01044301)

Parts No.	Stock No.	Description	Parts No.	Stock No.	Description
•Transistor			wQ12	46359801	2SC2001
mQ1	46367001	2SA1115	or 48055901	2SD1468S	
	or 48058601	2SA933S	wQ13	46359801	2SC2001
ΔmQ2	46614101	2SC3243	or 48055901	2SD1468S	
Δ	or 48000901	2SC2060	wQ14	46367101	2SC2603
ΔmQ3	46614001	2SA1283	or 48058801	2SC1740S	
Δ	or 48000801	2SA934	wQ15	46367101	2SC2603
ΔmQ4	03083901	2SD313HP	or 48058801	2SC1740S	
Δ	or 48369801	2SC1826	wQ16	46614101	2SC3243
•IC			or 48000901	2SC2060	
ΔmIC1	48470500	μPC7812H	wQ17	46367101	2SC2603
Δ	or 48567100	AN7812	or 48058801	2SC1740S	
ΔmIC2	46359400	L78N05	wQ18	46359801	2SC2001
Δ	or 48599500	AN78N05	or 48055901	2SD1468S	
•Diode			wQ19	46359801	2SC2001
ΔmD1	03117700	10E-2	or 48055901	2SD1468S	
Δ	or 83005000	1N4002	wQ20	46367101	2SC2603
ΔmD2	03117700	10E-2	or 48058801	2SC1740S	
Δ	or 83005000	1N4002	wQ101	48229200	DTA124XS
ΔmD3	03117700	10E-2	wQ102	48229200	DTA124XS
Δ	or 83005000	1N4002	wQ103	48229200	DTA124XS
ΔmD4	03117700	10E-2	wQ104	48229200	DTA124XS
Δ	or 83005000	1N4002	•IC		
ΔmD5	03117700	10E-2	wIC1	48840900	LC7800
Δ	or 83005000	1N4002	wIC2	48840900	LC7800
ΔmD6	03117700	10E-2	wIC3	48840700	M50742-405SP
Δ	or 83005000	1N4002	wIC4	46149600	BA6208
ΔmD7	03117700	10E-2	wIC5	46149600	BA6208
Δ	or 83005000	1N4002	wX01	48241600	Ceramic OSC Element KBR 4.0MS
ΔmD8	03117700	10E-2	•Diode		
Δ	or 83005000	1N4002	wD1	03117600	1S2473T77
ΔmD9	03117700	10E-2	or 46086000	1S1588TP-3	
Δ	or 83005000	1N4002	wD2	03117600	1S2473T77
ΔmD10	03117700	10E-2	or 46086000	1S1588TP-3	
Δ	or 83005000	1N4002	wD3	03117600	1S2473T77
mD13	03117600	1S2473T77	or 46086000	1S1588TP-3	
or 46086000	1S1588TP-3		wD4	03117600	1S2473T77
ΔmD14	03117600	1S2473T77	or 46086000	1S1588TP-3	
Δ	or 46086000	1S1588TP-3	wD5	03117600	1S2473T77
•Zener Diode			or 46086000	1S1588TP-3	
mDZ1	46113300	05Z10-Y	wR1	48773200	4.7kΩX8 A.R.
or 46113400	05Z10-Z		wR2	48765800	4.7kΩX4 A.R.
mDZ2	46112800	05Z8.2-Z	wR3	48773200	4.7kΩX8 A.R.
mDZ3	46112800	05Z8.2-Z	wR4	48773200	4.7kΩX8 A.R.
mDZ4	46114000	05Z12-Z	wR5	48773200	4.7kΩX8 A.R.
•Transistor			wR6	48773200	4.7kΩX8 A.R.
xQ1	46367101	2SC2603	ΔwR48	46248500	22Ω 1W N.I.R.
or 48058801	2SC1740S		ΔwR51	46624100	68Ω 2W N.I.R.
xQ2	46367101	2SC2603	ΔwR62	46624100	68Ω 2W N.I.R.
or 48058801	2SC1740S		ΔwR63	46490900	91Ω 1/6W C.R.
xQ3	46367101	2SC2603	wR65	46624100	68Ω 2W N.I.R.
or 48058801	2SC1740S				
ΔmR1	46230200	1kΩ 1/2W N.I.R.			
ΔmR2	46230000	680Ω 1/2W N.I.R.			
ΔmR4	46230000	1kΩ 1/2W N.I.R.			
ΔmR5	46250100	470Ω 1W N.I.R.			
•IC					
xiC1	48179900	CX-20187			
xFL1	48668300	DOLBY Filter			
or 83013500	DOLBY Filter				
xFL2	48848400	DOLBY SQ Filter			
or 83011000	DOLBY SQ Filter				

2-3. F-5756 Power SW. Board

Parts No.	Stock No.	Description
△pC1	46425800	0.01μF 400V C.C.
△	or 46943200	0.01μF 400V C.C.
△	or 48186700	0.01μF 400V C.C.
△pS1	46364300	Push SW., POWER (XX-V. UL.EU.UK)
△	or 83004200	Push SW., POWER (XX-V. UL.EU.UK)
△	83004200	Push SW., POWER (CSA)
△	or 48065000	Push SW., POWER (CSA)

2-4. F-5757 Power Indicator Board

Parts No.	Stock No.	Description
nLD3	48849300	SEL3913K POWER

2-5. F-5758 A-Side Control SW. Board

Parts No.	Stock No.	Description
•LED		
nLD1	48841200	SEL3910A PLAY
oS1	46708100	Push SW., ◀◀
	or 83000300	Push SW., ◀◀
oS2	46708100	Push SW., PLAY
	or 83000300	Push SW., PLAY
oS3	46708100	Push SW., STOP
	or 83000300	Push SW., STOP
oS4	46708100	Push SW., ▶▶
	or 83000300	Push SW., ▶▶

2-6. F-5759 B-Side Control SW. Board

Parts No.	Stock No.	Description
•LED		
nLD2	48841200	SEL3910A PLAY
oS5	46708100	Push SW., ◀◀
	or 83000300	Push SW., ◀◀
oS6	46708100	Push SW., PLAY
	or 83000300	Push SW., PLAY
oS7	46708100	Push SW., STOP
	or 83000300	Push SW., STOP
oS8	46708100	Push SW., ▶▶
	or 83000300	Push SW., ▶▶

2-7. F-5760 Rec Level VR & Peak Level Meter Board

Parts No.	Stock No.	Description
•IC		
nIC11	46129100	BA6124
•LED		
nLD11	48841300	SEL3813A, PEAK LEVEL METER
nLD12	48841300	SEL3813A, PEAK LEVEL METER
nLD13	48841300	SEL3813A, PEAK LEVEL METER
nLD14	48841300	SEL3813A, PEAK LEVEL METER
nLD15	48841300	SEL3813A, PEAK LEVEL METER
nLD16	48841100	SEL3210S, REC

Parts No.	Stock No.	Description
oS9	46708100	Push SW., DUBBING (A ▶ B)
	or 83000300	Push SW., DUBBING (A ▶ B)
oS10	46708100	Push SW., DUBBING (A ▶ B)
	or 83000300	Push SW., DUBBING (A ▶ B)
oS11	48240500	Push SW., REC
	or 83004000	Push SW., REC
oS12	48240500	Push SW., REC MUTE PAUSE
	or 83004000	Push SW., REC MUTE PAUSE
oS13	48240500	Push SW., CD SYNCHRO REC
	or 83004000	Push SW., CD SYNCHRO REC
oS14	48158200	Slide SW., DOLBY NR
vVR1	83008600	50kΩ V.R., REC LEVEL adj.
	or 48846200	50kΩ V.R., REC LEVEL adj.

2-8. F-5761 A-Side Play Amp. Board

(Stock No. 01044901)

Parts No.	Stock No.	Description
•Transistor		
vQ1	46367101	2SC2603
	or 46367301	2SC2458
	or 48058801	2SC1740S
vQ2	46367101	2SC2603
	or 46367301	2SC2458
	or 48058801	2SC1740S
vQ4	46367101	2SC2603
	or 46367301	2SC2458
	or 48058801	2SC1740S
•IC		
vIC1	48840800	BA3416BL
vVR1	48079400	22kΩ S.V.R., P.B. Level adj.
	or 83010400	20kΩ S.V.R., P.B. Level adj.
vVR2	48079400	22kΩ S.V.R., P.B. Level adj.
	or 83010400	20kΩ S.V.R., P.B. Level adj.

2-9. F-5762 A-Side Play Amp. Dubbing Board

(Stock No. 01045001)

Parts No.	Stock No.	Description
•Transistor		
vQ21	46367101	2SC2603
	or 46367301	2SC2458
	or 48058801	2SC1740S
vQ22	46367101	2SC2603
	or 46367301	2SC2458
	or 48058801	2SC1740S
vQ23	46367001	2SA1115
	or 46392001	2SA1175
	or 48058601	2SA933S
vQ24	46367001	2SA1115
	or 46392001	2SA1175
	or 48058601	2SA933S
•IC		
vIC21	46580100	M5218P
vIC22	07224800	TC4066BP
	or 46421000	μPD4066BC
	or 48054500	MSM4066BRS
•Zener Diode		
vDZ21	48552300	MTZ5.6AT-77
	or 48552400	MTZ5.6BT-77
	or 48631100	RD5.6B1 ES
	or 48631200	RD5.6B2 ES

2-10. F-5763 B-Side Rec/Play Amp. Board (Stock No. 01045101)

Parts No.	Stock No.	Description
•Transistor		
vQ51	46367101	2SC2603
	or 46367301	2SC2458
	or 48058801	2SC1740S
vQ52	46367101	2SC2603
	or 46367301	2SC2458
	or 48058801	2SC1740S
vQ53	46367101	2SC2603
	or 46367301	2SC2458
	or 48058801	2SC1740S
vQ54	46367101	2SC2603
	or 46367301	2SC2458
	or 48058801	2SC1740S
vQ55	46367101	2SC2603
	or 46367301	2SC2458
	or 48058801	2SC1740S
vQ56	46367101	2SC2603
	or 46367301	2SC2458
	or 48058801	2SC1740S
vQ57	46367001	2SA1115
	or 46392001	2SA1175
	or 48058601	2SA933S

Parts No.	Stock No.	Description
vQ58	46367101	2SC2603
	or 46367301	2SC2458
	or 48058801	2SC1740S
•IC		
vIC51	46580100	M5218P
•Zener Diode		
vDZ51	48552300	MTZ5.6AT-77
	or 48552400	MTZ5.6BT-77
	or 48631100	RD5.6B1 ES
	or 48631200	RD5.6B2 ES
vL51	46090500	Inductor 2.7mH
vVR51	48079600	47kΩ S.V.R., REC Level adj.
	or 83010500	50kΩ S.V.R., REC Level adj.
vVR52	48079600	47kΩ S.V.R., METAL Rec Level adj.
	or 83010500	50kΩ S.V.R., METAL Rec Level adj.

3. INTERIOR BLOCK DIAGRAM OF IC

• BA6208 (Motor Drive)

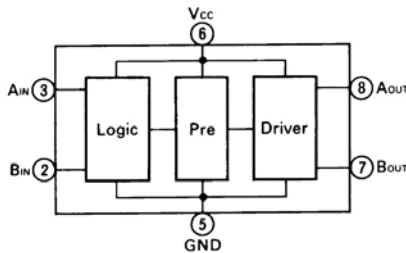

Input		Output		Output Mode
Input A	Input B	Output A	Output B	
1	1	L	L	Motor Short
1	0	H	L	Normal Turn
0	1	L	H	Reverse Turn
0	0	-	-	Motor Open

1: More than 2.0V, 0: Less than 0.8V

• BA3416BL (Play Back Pre Amp.)

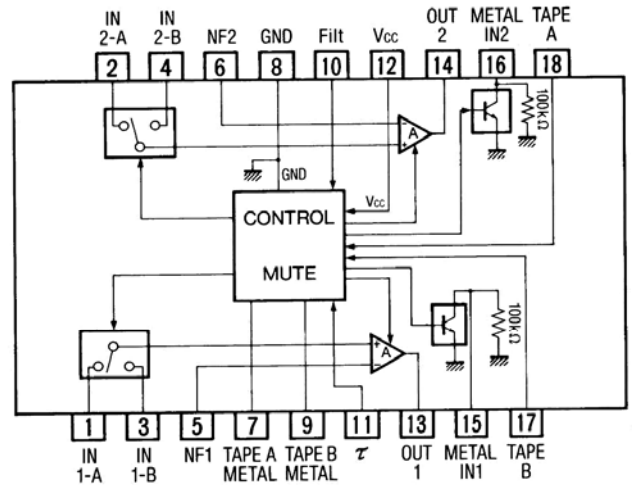

• BA6124 (LED Drive)

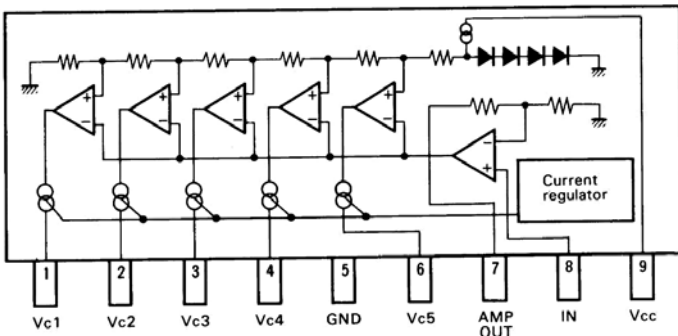

• CX20187 (Dolby Noise Reduction)

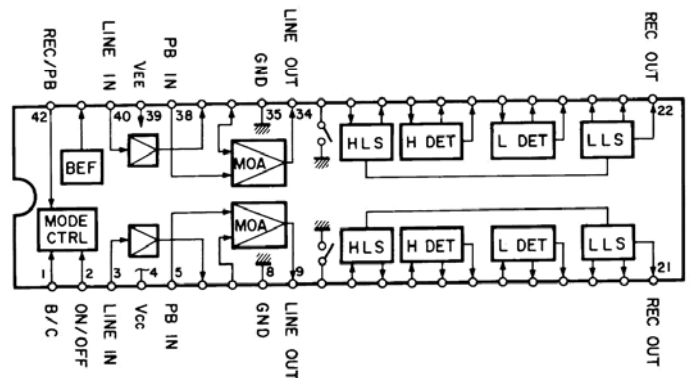

• LC7800 (Input Expander)

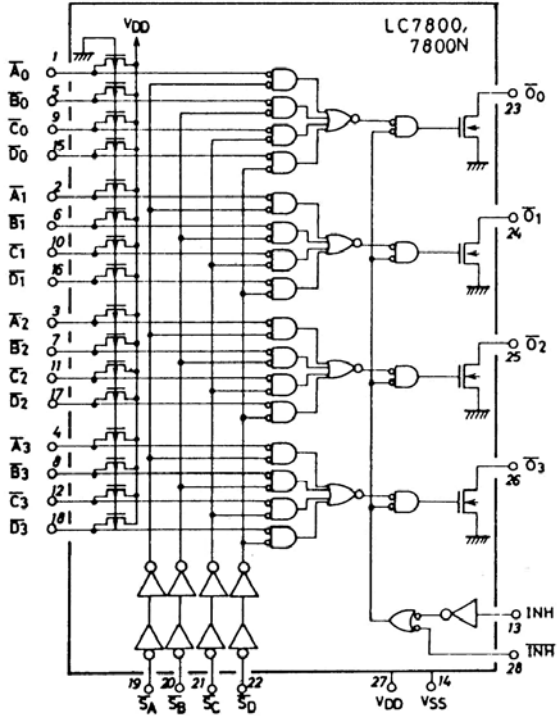

• TC4066BP, MSM4066BPS, μ PD4066BC, (Quad Analog SW.)

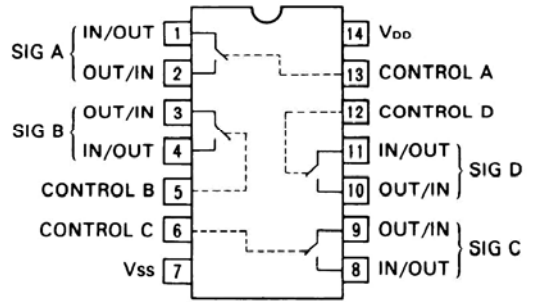

• M5218P, M5220P (OP Amp.)

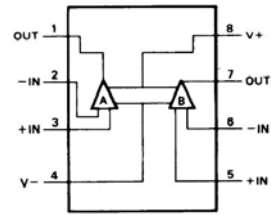

Input																Output									
DATA Input												Select Input													
A			B			C			D			C0	C1	C2	C3	INH	INH	O0	O1	O2	O3				
A0	A1	A2	A3	B0	B1	B2	B3	C0	C1	C2	C3	D0	D1	D2	D3	C0	C1	C2	C3	INH	INH	O0	O1	O2	O3
0	1	1	1	1	1	1	1	1	1	1	1	1	1	1	0	1	1	1	0	1	1	1	1		
1	0	1	1	1	1	1	1	1	1	1	1	1	1	1	0	1	1	1	0	1	1	1	1		
1	1	0	1	1	1	1	1	1	1	1	1	1	1	1	0	1	1	1	0	1	1	1	1		
1	1	1	0	1	1	1	1	1	1	1	1	1	1	1	0	1	1	1	0	1	1	1	1		
1	1	1	1	0	1	1	1	1	1	1	1	1	1	1	1	0	1	1	0	1	1	1	1		
1	1	1	1	1	0	1	1	1	1	1	1	1	1	1	1	0	1	1	0	1	1	1	1		
1	1	1	1	1	1	0	1	1	1	1	1	1	1	1	1	0	1	1	0	1	1	1	1		
1	1	1	1	1	1	1	0	1	1	1	1	1	1	1	1	0	1	1	0	1	1	1	1		
1	1	1	1	1	1	1	1	0	1	1	1	1	1	1	1	1	0	1	0	1	1	1	1		
1	1	1	1	1	1	1	1	1	0	1	1	1	1	1	1	1	0	1	0	1	1	1	1		
1	1	1	1	1	1	1	1	1	1	0	1	1	1	1	1	1	0	1	0	1	1	1	1		
1	1	1	1	1	1	1	1	1	1	1	0	1	1	1	1	1	0	1	0	1	1	1	1		
1	1	1	1	1	1	1	1	1	1	1	1	0	1	1	1	1	0	1	0	1	1	1	1		
1	1	1	1	1	1	1	1	1	1	1	1	1	0	1	1	1	0	1	0	1	1	1	1		
*	*	*	*	*	*	*	*	*	*	*	*	*	*	*	*	*	*	*	*	1	*	1	1	1	
*	*	*	*	*	*	*	*	*	*	*	*	*	*	*	*	*	*	*	*	0	*	1	1	1	
*	*	*	*	*	*	*	*	*	*	*	*	*	*	*	*	*	*	*	*	*	1	1	1	1	

1: [H] Level/O: [L] Level/*: dont care

4. TIMING CHART OF CONTROL IC M50742-405SP

4-1. Timing Charts

• a, b-Mecha Play → Stop → F.F (▷▷) → REW (◁◁) → Stop

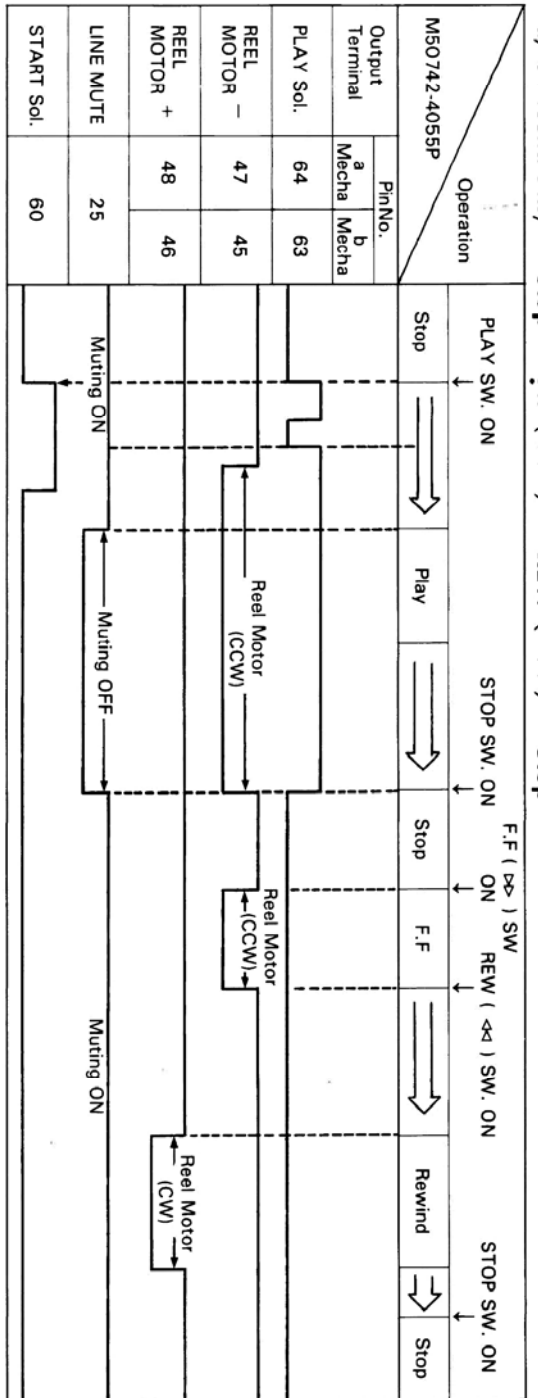

• b-Mecha Rec → Rec Pause (ON, OFF) → Rec → Stop

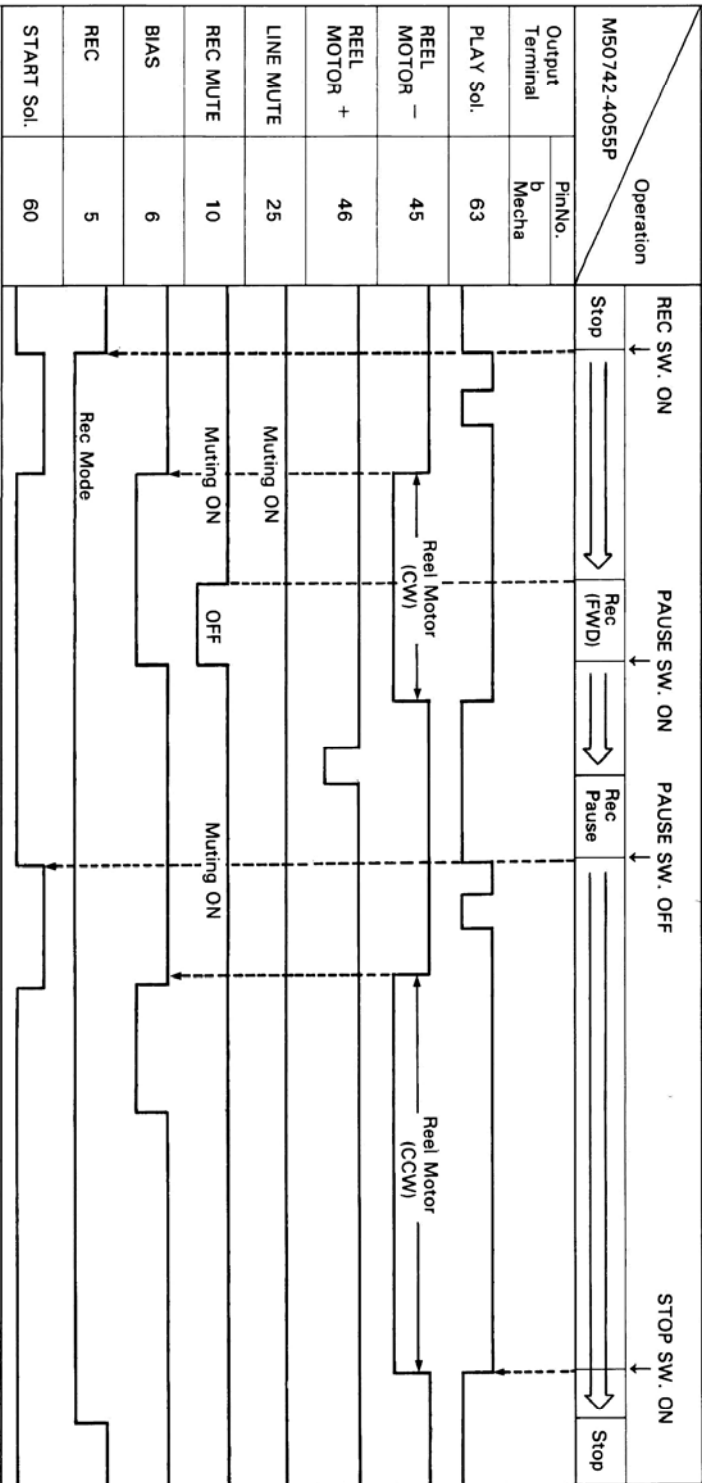

4-2. Terminal Function of IC M50742-405SP

Pin No.	Pin Name	i/o	Description	ACTIVE	
				H	L
21~18	P34~P37	o	Terminals for outputting key matrix return timing signals.		
33~40	P57~P50	i	Terminals for inputting key matrix timing signals.		
4	a PLAY	o	This terminal outputs an "H" signal in PLAY or AMPS mode, but an "L" signal in REC mode.	○	
5	b REC	o	This terminal outputs an "L" signal in REC or DUBBING mode of b-side mechanism.		○
6	b BIAS	o	This terminal outputs an "L" signal in REC or DUBBING mode of b-side mechanism.		○
7	b PLAY	o	This terminal outputs an "H" signal in PLAY or AMPS mode, but an "L" signal in REC mode.	○	
8	DUBBING	o	This terminal outputs an "H" signal in DUBBING mode. And terminal for outputting a signal for DUBBING indicator LED.	○	
10	REC MUTE	o	Terminal for outputting REC MUTE signal. This terminal outputs an "H" signal until set to PAUSE mode, when REC MUTE key is depressed in REC mode.	REC Mute ON	REC Mute OFF
12	a ▷	o	Terminal for outputting a signal for driving ▷ indicator LED of a-side mechanism.		○
15	b ▷	o	Terminal for outputting a signal for driving ▷ indicator LED of b-side mechanism.		○
17	b REC	o	Terminal for outputting a signal for driving REC indicator LED of b-side mechanism.		○
23	a REEL PULSE	i	Terminal for inputting a pulse signal detected by reel motor driver circuit of a-side mechanism to perform auto-stop operation.		
25	LINE MUTE	o	Terminal for outputting LINE MUTE signal. If at "H" level, LINE OUT is muted.	Line Mute ON	Line Mute OFF
26	b REEL PULSE	i	Terminal for inputting a pulse signal detected by reel motor driver circuit of b-side mechanism to perform auto-stop operation.		
42	CAP FAST	o	Terminal for switching capstan motor speed from NORMAL speed dubbing to HIGH speed dubbing or vice versa in DUBBING mode. NORMAL speed dubbing at "L", HIGH speed at dubbing "H". Further, in HIGH speed dubbing, f-characteristics of	HIGH Speed Dubbing	NORMAL Speed Dubbing

Pin No.	Pin Name	i/o	Description	ACTIVE	
				H	L
43	b REEL FAST	o	Terminal for switching b-side mechanism reel motor speed from NORMAL play to FF/REW or vice versa. If at "L" level, FF/REW speed is obtained.	Normal Play	F.F & REW
44	a REEL FAST	o	Terminal for switching a-side mechanism reel motor speed from NORMAL play to FF/REW or vice versa. If at "L" level, FF/REW speed is obtained.	Normal Play	FF & REW
45	b REEL M+	o	If at "L" level, b-side mechanism reel motor rotates CW.		○
46	b REEL M-	o	If at "L" level, b-side mechanism reel motor rotates CCW.		○
47	a REEL M+	o	If at "L" level, a-side mechanism reel motor rotates CW.		○
48	a REEL M-	o	If at "L" level, a-side mechanism reel motor rotates CCW.		○
49	AMPS	i	Terminal for inputting music blank signals in AMPS operation.	Music play	Music blank
50	b LEADER	i	When photosensor detects a tape leader during b-side mechanism operation, tape running direction is switched.		○
51	a LEADER	i	When photosensor detects a tape leader during a-side mechanism operation, tape running direction is switched.		○
41 53~56	P17 P03~ P00	i/o i	Terminals for remote-control computer selector, to which data from a remote-control system controller is inputted.		
60	SOL START	o	Terminal for generating a driving current to energize PLAY plunger. The plunger is initially energized by a pulse (┘┘).		
63	b PLAY SOL.	o	Terminal for outputting a current to hold b-side mechanism PLAY plunger. If at "H", PLAY plunger is held.	○	
64	a PLAY SOL.	o	Terminal for outputting a current to hold b-side mechanism PLAY plunger. If at "H", PLAY plunger is held.	○	
29 30	Xin Xout	- -	Terminals to connect a OSC.		
1	V _{DD}	-	Power supply terminal.		
57	SELECT CD	i/o	When CD synchro Rec SW., (OS13) is switched "ON", set the selector of Amp. AT CD position, output ACTIVE "H".	○	
58	CD synchro REC	i/o	When CD synchro Rec SW., (OS13) is switched "ON", set the selector CD Rector player play output Active "H".	○	

5. ADJUSTMENTS

5-1. Tape Speed Adjustment

Note: 1. Use Sansui Test Tape, SCT-35K.
 (3 kHz signals are recorded on the tape).
 2. Connections are shown in Fig. 5-1.

Fig. 5-1

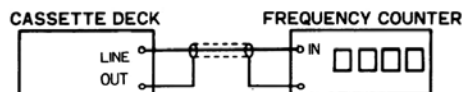

STEP	SUBJECT	MEASURE OUTPUT	SETTING	ADJUSTMENT	ADJUST FOR	REMARKS
1.	Normal speed Adj.	LINE OUT. Frequency counter	Playback the TEST TAPE SCT-S3K. B Side Mecha.	Turn the tVR2 on the F-5735 board (See Fig. 5-2)	3000Hz ₋ ^{+30Hz} _{OHZ}	
2.	High Speed Adj.	Same as above.	1. Short between Point (A) (t R1, F-5735 and GND (See Fig. 5-2) 2. Play back the Test Tape SCT-35K. B side Mecha.	Turn the tvR1 on the F-5735 board (See Fig. 5-2)	6000Hz ₋ ^{+60Hz} _{OHZ}	

VR1?

• Fig. 5-2 F-5735 Speed Control Board

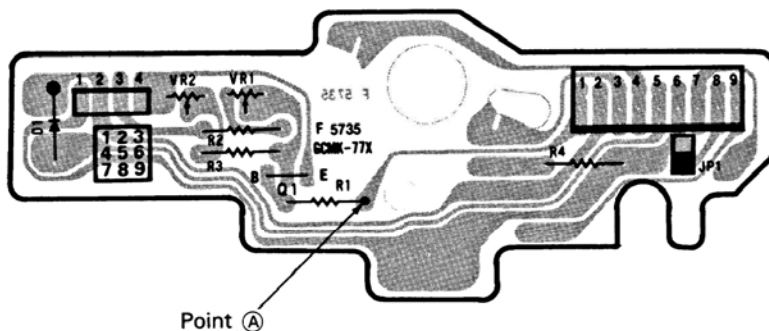

5-2. Playback Adjustment

Note: 1. Before this adjustment, clean REC/P.B. head surface.
 2. For this adjustment, use Sansui Test Tape, SCT-F10K, and SCT-L400N.
 3. Set the Dolby NR switch to OFF.
 4. Connections are shown in Fig. 5-3.

Fig. 5-3

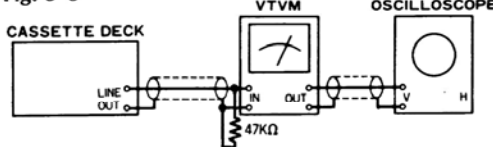
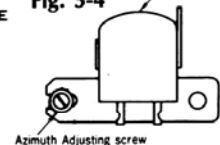

Fig. 5-4



1) a-Side Mecha. Adjustment

STEP	SUBJECT	MEASURE OUTPUT	SETTING	ADJUSTMENT	ADJUST FOR	REMARKS
1.	P.B. Head Adj.	LINE OUT VTVM and Scope	Playback the TEST TAPE SCT-F10K	Adjust the azimuth adjusting screw in Fig. 5-4.	MAX. Output both channels.	After this adjustment, lock the screw with paint.
2.	Playback Level Adj.	Same as above	Playback the TEST TAPE SCT-L400N	Adjust each vVR1 (L-CH and R-CH, F-5761)	500mV ± 1dB	See Top View on Page 16.

2) b-Side Mecha. Adjustment

STEP	SUBJECT	MEASURE OUTPUT	SETTING	ADJUSTMENT	ADJUST FOR	REMARKS
1.	REC/P.B. Head Adj.	LINE OUT VTVM and Scope	Playback the TEST TAPE SCT-F10K	Adjust the azimuth adjusting screw in Fig. 5-4.	MAX. Output both channels.	After this adjustment, lock the screw with paint.
2.	Playback Level Adj.	Same as above	Playback the TEST TAPE SCT-L400N	Adjust each vVR2 (L-CH and R-CH, F-5761)	500mV ± 1dB	See Top View on Page 16.

5-3. REC Level & Frequency Response Adjustment <b Side Mecha. only>

- Note: 1. Connections are shown in Fig. 5-5.
2. Set the Dolby NR switch to OFF.
3. Short between TP terminal pins on F-5754 (See Top View on page 15).

Fig. 5-5

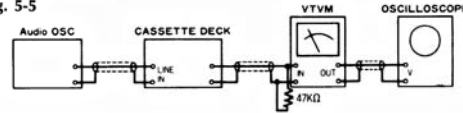

STEP	SUBJECT	INPUT SIGNAL	MEASURE OUTPUT	SETTING	ADJUSTMENT	REMARKS
1.	REC Level Adj.	Feed 1kHz from Audio S.G. into LINE IN.	LINE OUT, VTVM and Scope	Load the TEST TAPE SCT-SA. 1. Push the PAUSE and REC knob. 2. Adjust the output level of Audio SG. for obtaining 200mV on VTVM. 3. Push the PAUSE knob, then record the 1kHz signal. 4. Playback the 1kHz signal. 5. Confirm that the output levels on both channels are 200mV±2dB on VTVM.	1. If not turn vVR51 (REC, L-CH, F-5763) and vVR51 (REC, R-CH, F-5763) until output level 200mV±2dB on both channels are obtained.	vVR51 (REC, L-CH) and vVR51 (REC, R-CH) are shown in Top View on Page 15.
2.	Frequency Response Adj.	Feed 1kHz and 10kHz 10mV, from Audio S.G. into LINE IN.	Same as above	Load the TEST TAPE SCT-SA. 1. Record the 1kHz and 10kHz signals. 2. Playback the 1kHz and 10kHz signals, then confirm that both output levels equal.	1. If not, adjust vVR101 (F-5754) for L-CH and vVR101 (F-5754) for R-CH slightly until the output levels will be equal.	
3.	METAL REC Level Adj.	Feed 1kHz, from Audio S.G. into LINE IN.	LINE OUT, VTVM and Scope	Load the TEST TAPE SCT-MA. 1. Push the PAUSE and REC knob. 2. Adjust the output level of Audio SG. for obtaining 200mV on VTVM. 3. Push the PAUSE knob, then record the 1kHz signal. 4. Playback the 1kHz signal. 5. Confirm that the output levels on both channels are 200mV±2dB on VTVM.	1. If not turn vVR52 (METAL, L-CH, F-5763) and vVR52 (METAL, R-CH, F-5763) until output level 200mV±2dB on both channels are obtained.	vVR52 (METAL, L-CH) and vVR52 (METAL, R-CH) are shown in Top View on page 15.

◆ List of Sansui Test Tape

Name of TEST TAPE	Recorded Frequency	Description	Equivalent To
SCT-F40	40 Hz	Playback Frequency Response Check	—
SCT-F1K	1 kHz	High Frequency Equalization Check	—
SCT-F10K	10 kHz	REC/PB Head Adjustment	—
SCT-L400N	400 Hz	Playback Level and Indicator Level Adjustment	—
SCT-S3K	3 kHz	Speed Check and Wow & Flutter Check	—
*SCT-AD NORMAL	—	Recording Bias Adjustment	TDK AD
*SCT-SA HIGH	—	REC/PB Level Adjustment	TDK SA
*SCT-MA (METAL)	—	Frequency Response Check	TDK MA

*Note: Some reference tapes marked * are not supplied. As these are equivalent to ones indicated above, please obtain these blank tapes on your side as possible.

6. OPERATIONS OF PINCH ROLLER & HEAD OF MECHANISM

A. Torque Transportation Flowchart

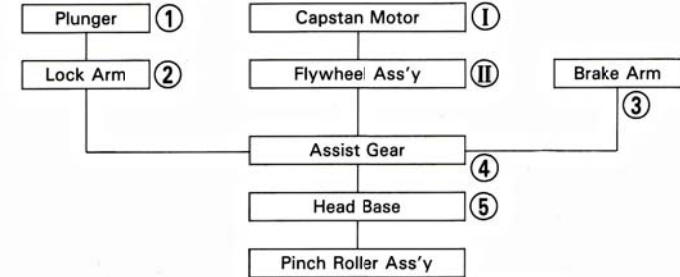

- The pinch roller is brought into pressure contact with the capstan shaft.

B. Front View of Mechanism Chassis

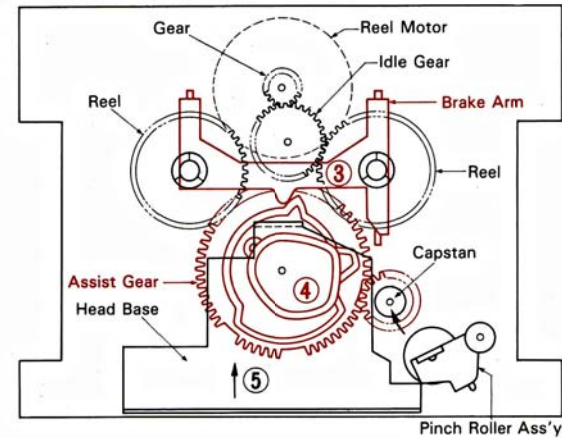

C. Rear View of Mechanism Chassis

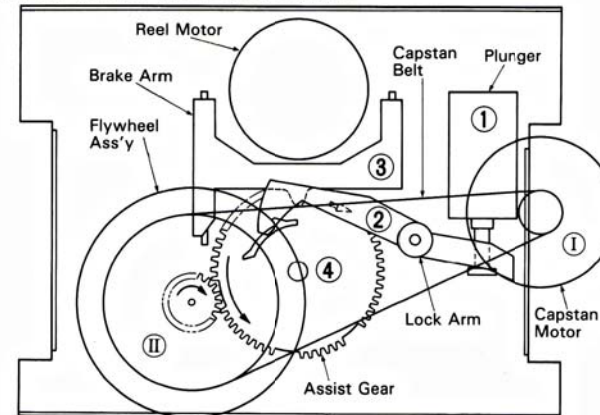

D. Cam Positions in the Modes of PLAY, FF, REW & STOP

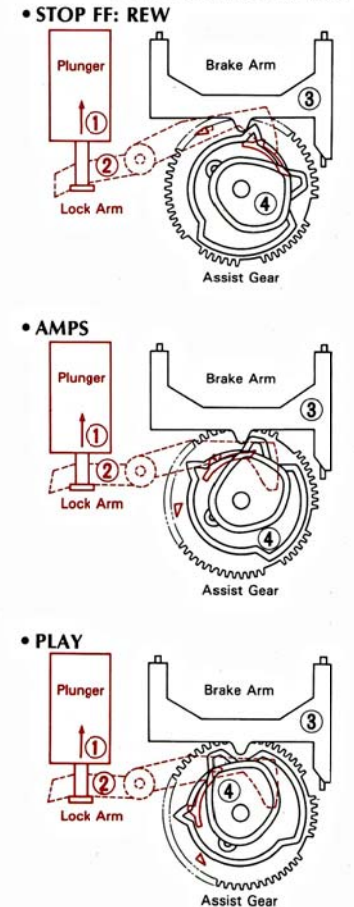

7. EXPLODED VIEW OF MECHANISM Ass'y & PARTS LIST

7-1. Front View of Mechanism Chassis

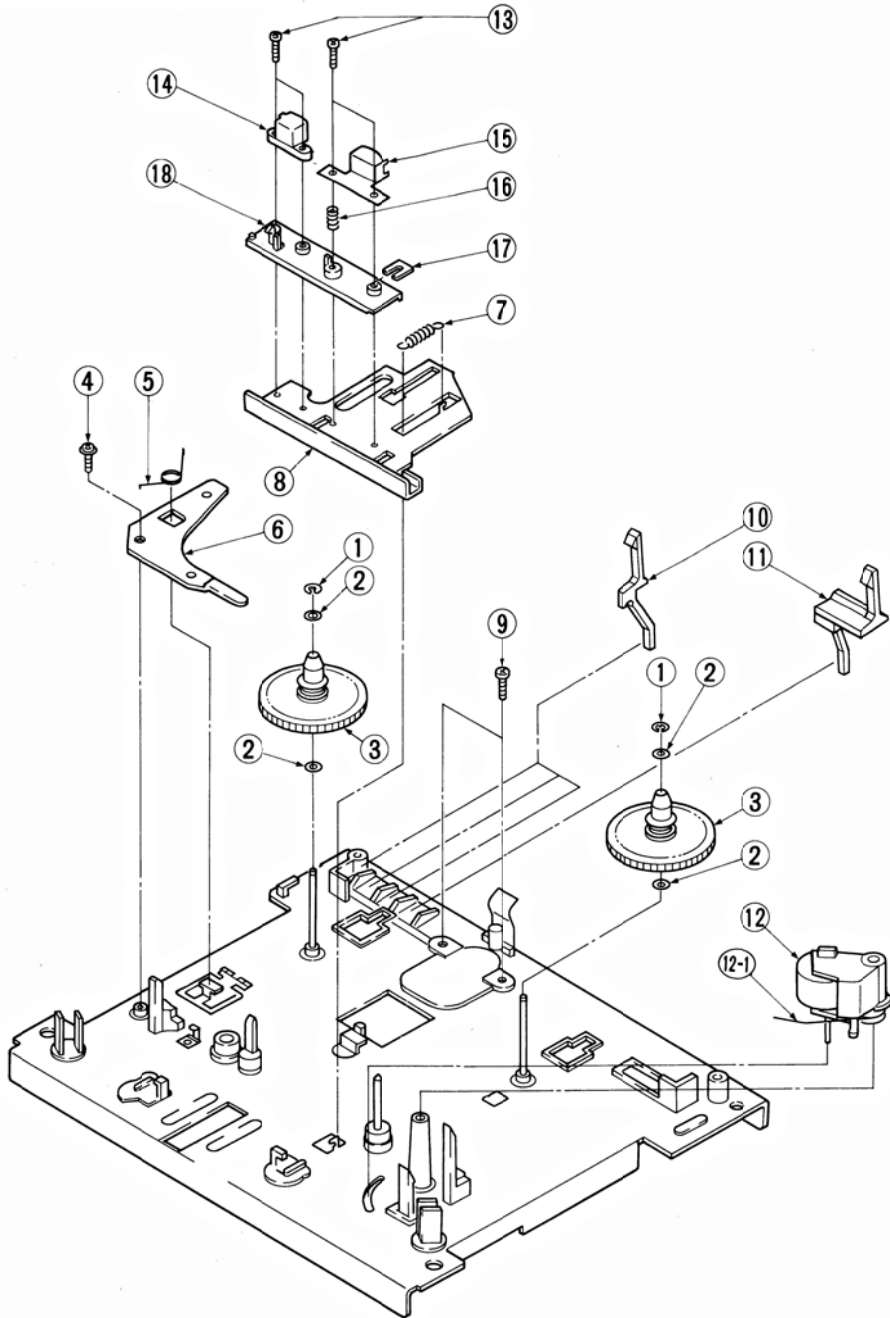

7-2. Rear View of Mechanism Chassis

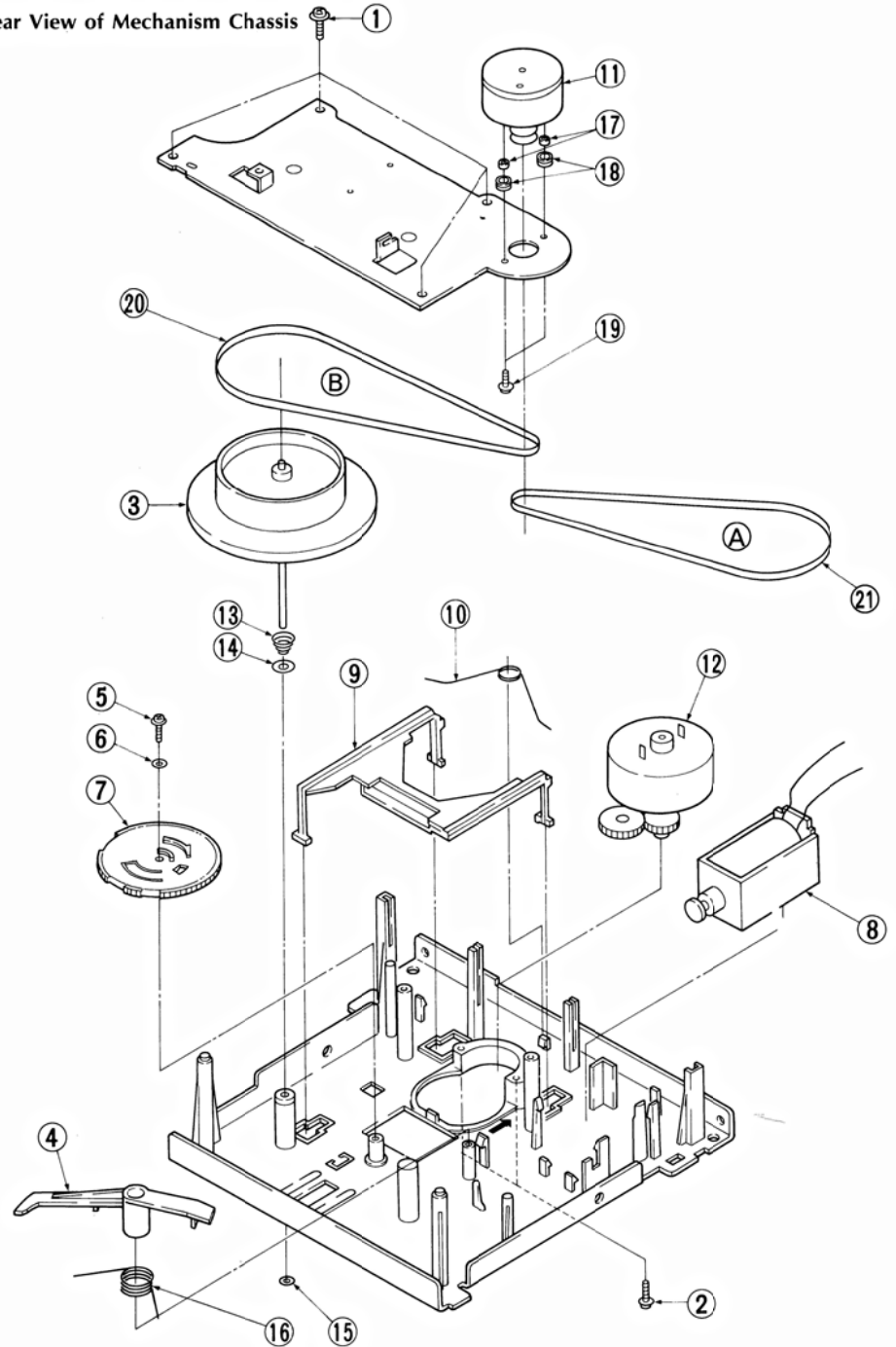

8. MAIN PARTS REPLACEMENT

• Parts List <Front View of Mechanism Chassis>

Parts No.	Stock No.	Description
1	27083100	Lit Washer D=1.6
2	27452200	Washer
3	27377700	Reel Gear Ass'y
4	48843500	M2x10 Screw,
5	27412400	Spring, eject
6		Eject Stopper
7	27378500	Spring, head base
8		Head Base
9	00421600	M2.6x12 Binding Head Screw
10	27368800	Switch Arm A
11	27368900	Switch Arm B (B-Side)
12	18157701	Pinch Roller Ass'y
12-1	27378200	Spring Pinch Roller
13	00420800	M2x10 Binding Head Srew
14	07997400	Erase Head (B-Side)
	46867800	Dummy Head (A-Side)
15	48589000	REC/PB Head
16	47406100	Spring, Azumuth
17	27470600	Space
18	27372100	Head Base

• Parts List <Rear View of Mechanism Chassis>

Parts No.	Stock No.	Description
1	18158700	M3x8 Screw,
2	00421600	M2.6x12 Screw,
3	27377300	Flywheel Ass'y
4	27370600	Lock Arm
5	48914100	M2x12 Truss Head Screw
6	27452200	Teflon Washer M2
7	27370700	Assist Gear
8	48844900	Plunger Solenoide
9	27370500	Brake Arm
10	27379300	Spring, Brake
11	48831200	Capstan Motor Ass'y
12	18157301	Reel Motor Ass'y
13	47530000	Spring, Flywheel
14	47404600	Washer, D=2.5
15	47404700	Nylon Washer, D=2.5
16	27378800	Spring, Lock Arm
17	27459800	Motor Collar
18	27459800	Motor Pushing
19	48913100	M2.6x4 Screw,
20	27413400	Capstan Belt (B-Side)
21	27401600	Capstan Belt (A-Side)
	84504900	Counter Belt

A. How to remove mechanical Ass'y A-Mechanism and B-Mechanism (See Page 16)

1. Remove the bonnet.
2. Remove the bottom plate.
3. Remove the side panel both right & left.
4. Loosen the two Screw (C) to remove PWB stay.
5. Loosen the two Screw (A) to remove Gear Holder (26) & Gear (27).
6. Remove the Belt from the Capstan Motor.
7. Loosen the Belt from the Tape Counter.
8. Loosen the Screw (B).

B. How to set the Capstan Belt (See Fig. 8-1)

Put the capstan belt of A and B mechanism to the capstan motor as shown Fig. 8-1.

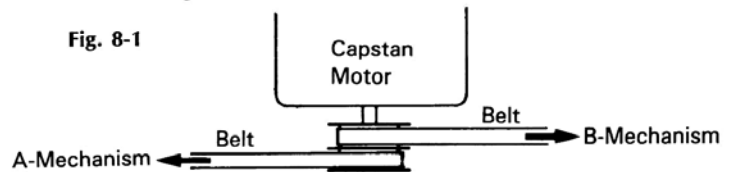

C. How to remove Reel Motor

1. Loosen the Screw (1) & (2) (See Page 13 Rear View of Mechanism Chassis).
2. Remove the lead wire of Plunger Solenoid from F-5735 Board (See Fig. 8-2).
3. Remove the Terminal of Reel Motor (12) from F-5735 Board (See Page 13 Rear View of Mechanism Chassis).

Fig. 8-2

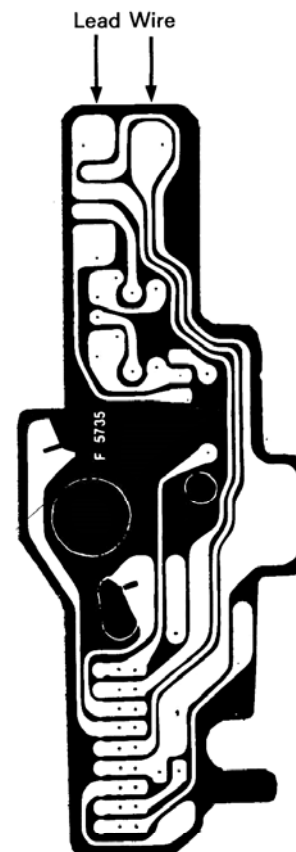

9. OTHER PARTS

• Front View

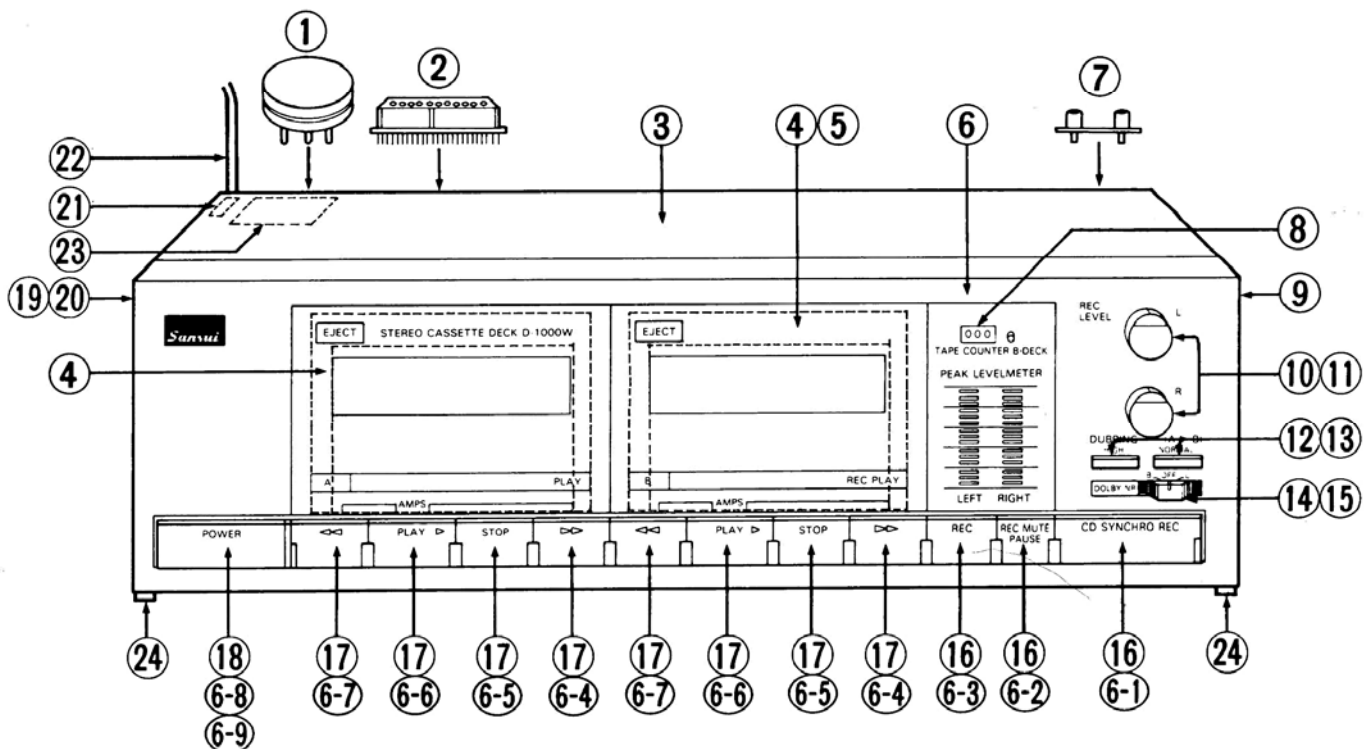

• Top View

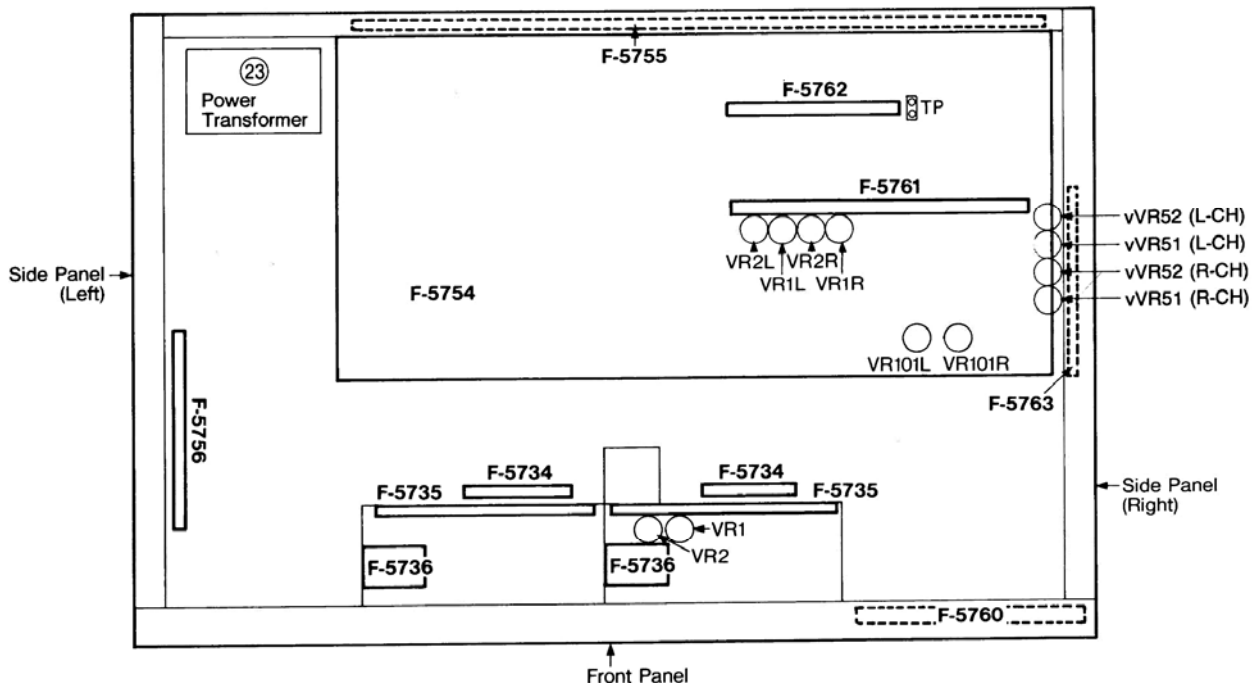

• Inside View of Front Panel

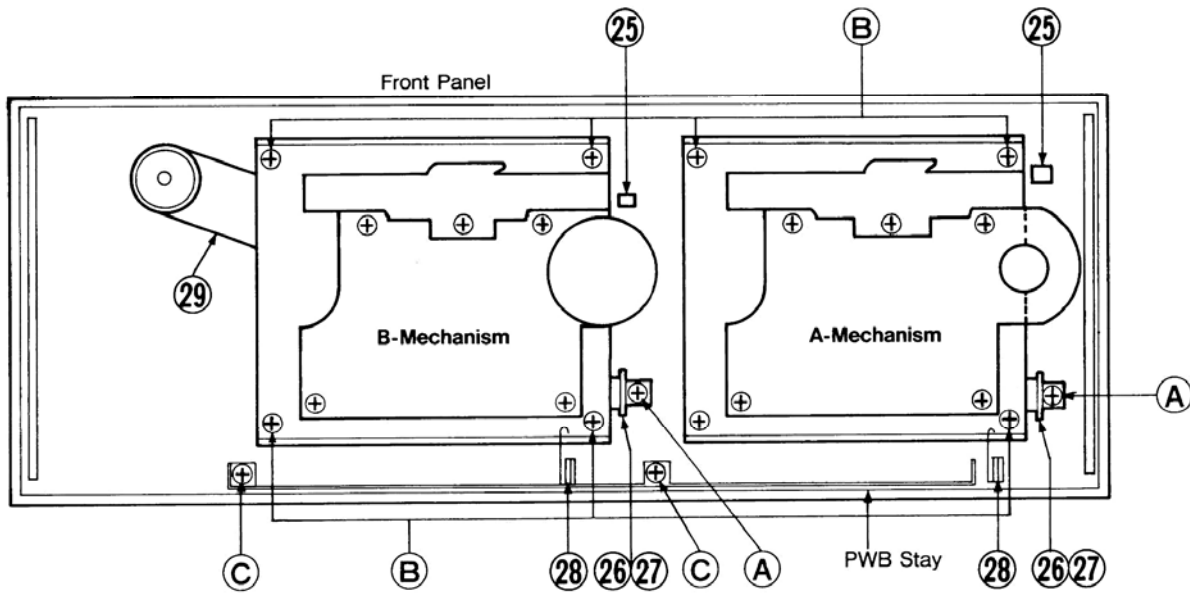

Parts List

Parts No.	Stock No.	Description
1	48484200 07204700	Plug, VOLTAGE SELECTOR (XX-V) Slide SW. VOLTAGE SELECTOR (EU.BS/UK.SEV)
2	48313900	ST SOCKET (10P.PIN) SYSTEM CONTROL
3	84504200	Bonnete
4	27411400	Cassette Holder Ass'y,
5	27410400	b-Side Cassette Lid Ass'y
6	02041501	Front Panel Ass'y (XX-V, CSA.EU.BS/UK.SEV)
	02041502	Front Panel Ass'y (UL)
6-1	84515800	Knob. CD SYNCHRO REC
6-2	84516600	Knob. REC MUTE PAUSE
6-3	84556700	Knob. REC MUTE PAUSE
6-4	84517000	Knob. ►►
6-5	84517100	Knob. STOP
6-6	84556600	Knob. Ass'y PLAY
6-7	84516900	Knob. ►
6-8	84517800	Knob. POWER
6-9	84505100	Knob Spring. POWER
7	83004300	4P Terminal LINE IN.OUT
	or 48845900	4P Terminal LINE IN.OUT
8	48835300	Tape Counter
9	84512100	Right Side Panel (XX-V, CSA.EU.BS/UK.SEV)
	84519900	Right Side Panel (UL)
10	84531300	Knob., REC LEVEL
11	83008600	50 kΩ (B) V.R., REC LEVEL
	or 48846200	50 kΩ (B) V.R., REC LEVEL
12	27466800	Push Knob., DUBBING (A ► B)
13	83000300	Push SW., DUBBING (A ► B)
	or 46708100	Push SW., DUBBING (A ► B)
14	84504600	Slide Knob., DOLBY NR

Parts No.	Stock No.	Description
15	48158200	Slide SW., DOLBY NR
16	83004000	Push SW., REC.REC MUTE PAUSE.CD SYNCHRO REC.
	or 48240500	Push SW., REC.REC MUTE PAUSE.CD SYNCHRO REC.
17	83000300	Push SW., ►►. STOP.PLAY. ◀
	or 46708100	Push SW., ►►. STOP.PLAY. ◀◀
18	83004200	Push SW., POWER (XX-V, UL.EU.BS/UK.SEV)
	or 46364300	Push SW., POWER (XX-V, UL.EU.BS/UK.SEV)
	83004200	Push SW., POWER (CSA)
	or 48065000	Push SW., POWER (CSA)
19	27410300	a-Side Cassette Lid Ass'y
20	84512000	Left Side panel (XX-V, CSA.EU.BS/UK.SEV)
	84519800	Left Side Panel (UL)
21	84514000	AC Cord Holder
22	38005400	Power Sypply Cord (XX-V)
	or 48837700	Power Sypply Cord (XX-V)
	38004700	Power Sypply Cord (UL)
	38005400	Power Sypply Cord (CSA)
	38004500	Power Sypply Cord (EU.SEV)
	38004300	Power Sypply Cord (BS/UK)
23	15029509	Power Transformer (XX-V)
	15029502	Power Transformer (UL.CSA)
	15029505	Power Transformer (EU.BS/UK.SEV)
24	07952800	Leg
25	48865100	Door Latch
26	83011400	Gear Holder
27	84532100	Gear
28	84505000	Damper Spring
29	84504900	Counter Belt

10. BLOCK DIAGRAM

10-1. Rec Operation

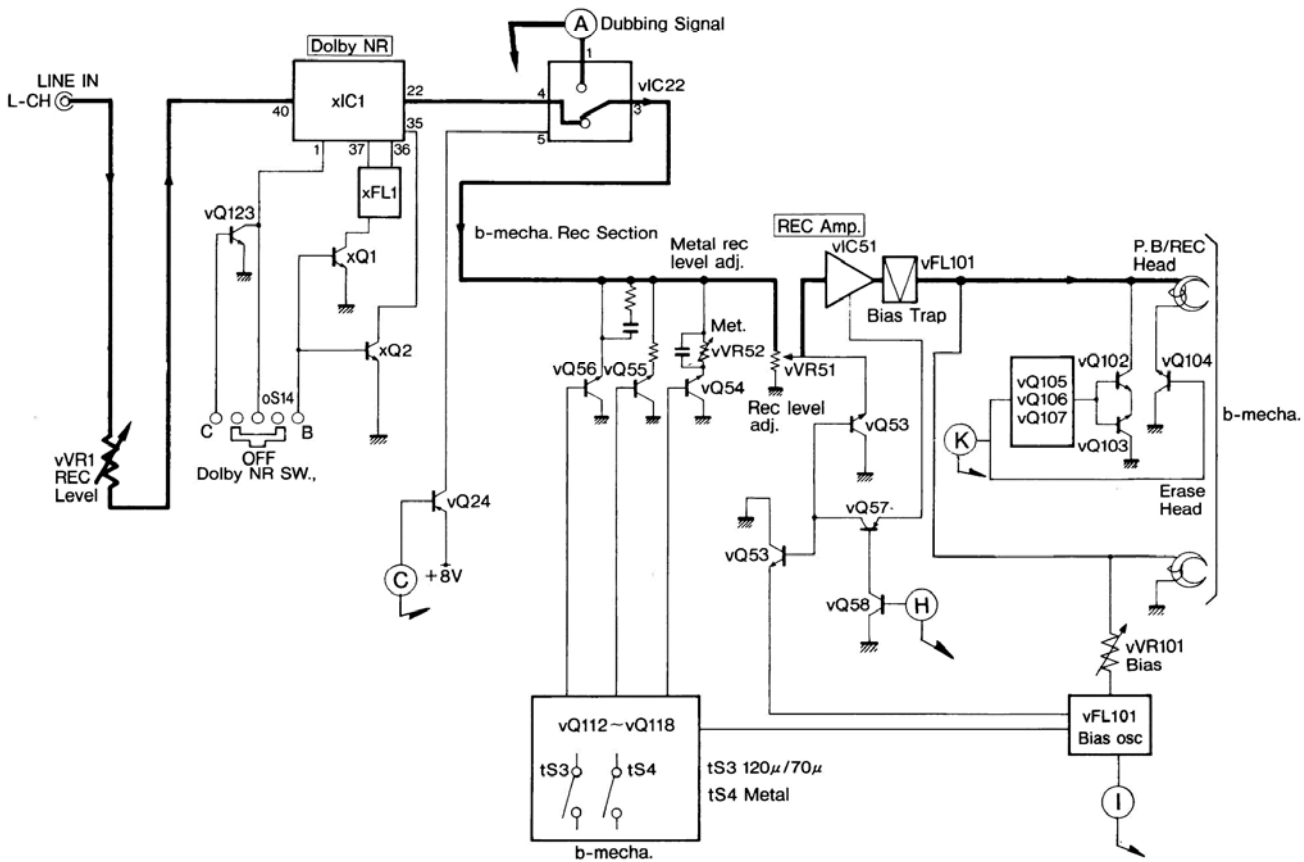

10-2. Playback/Dubbing Operation

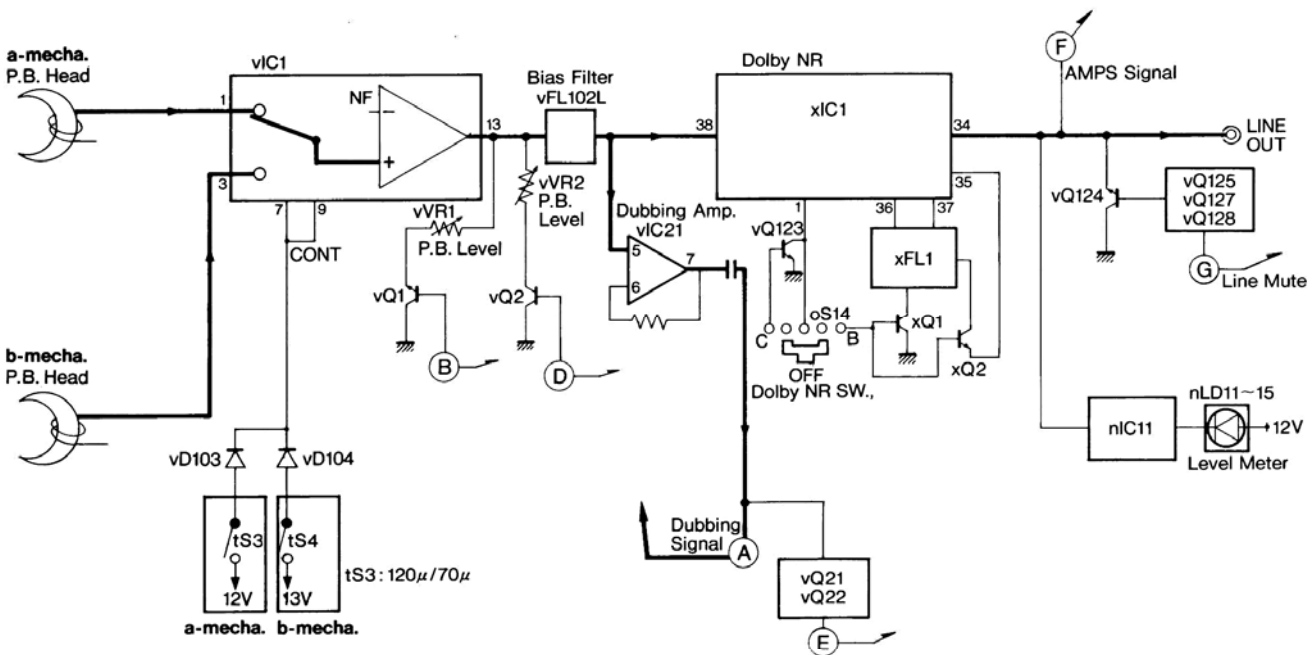

10-3. Logic Control Section

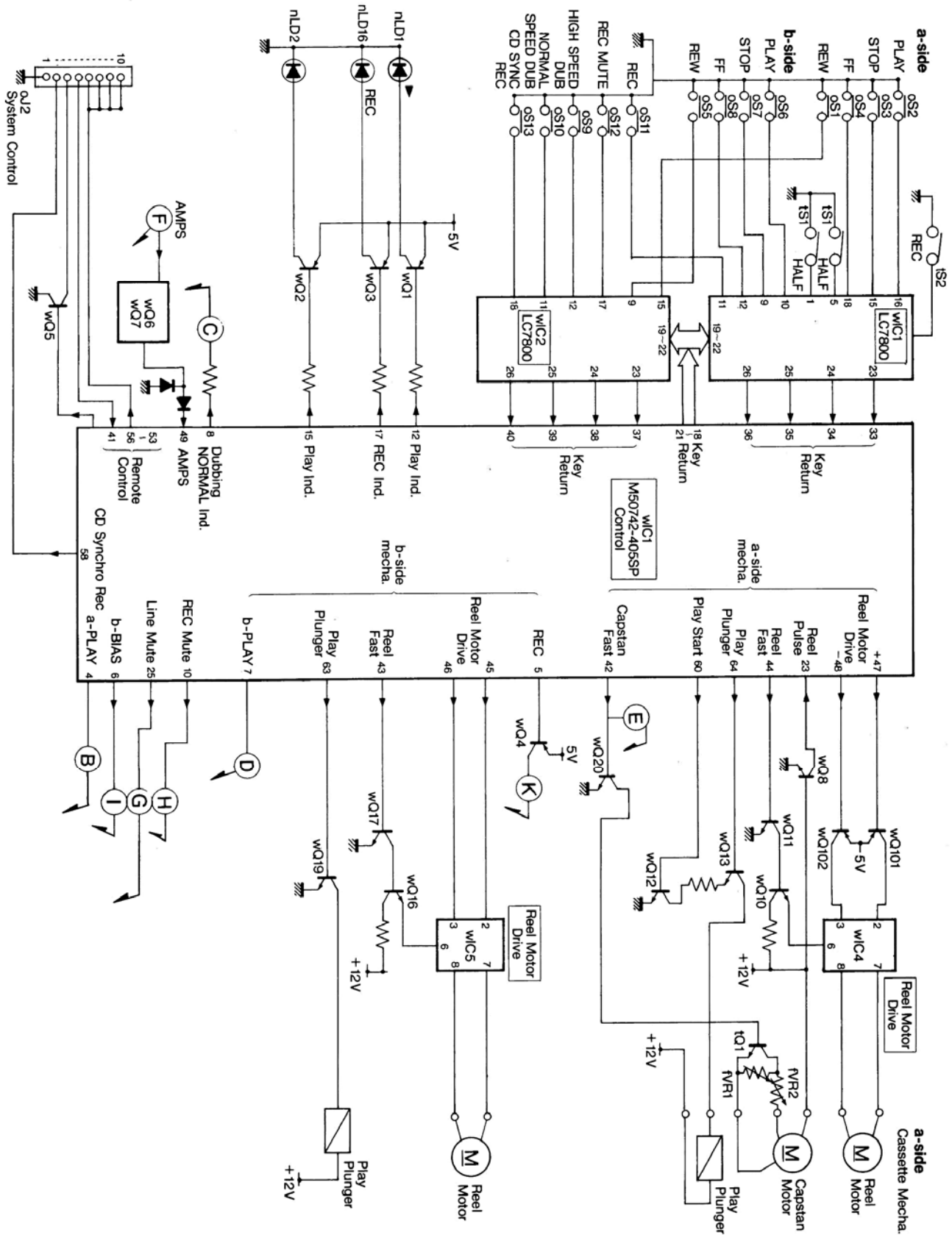

11. WIRING DIAGRAM

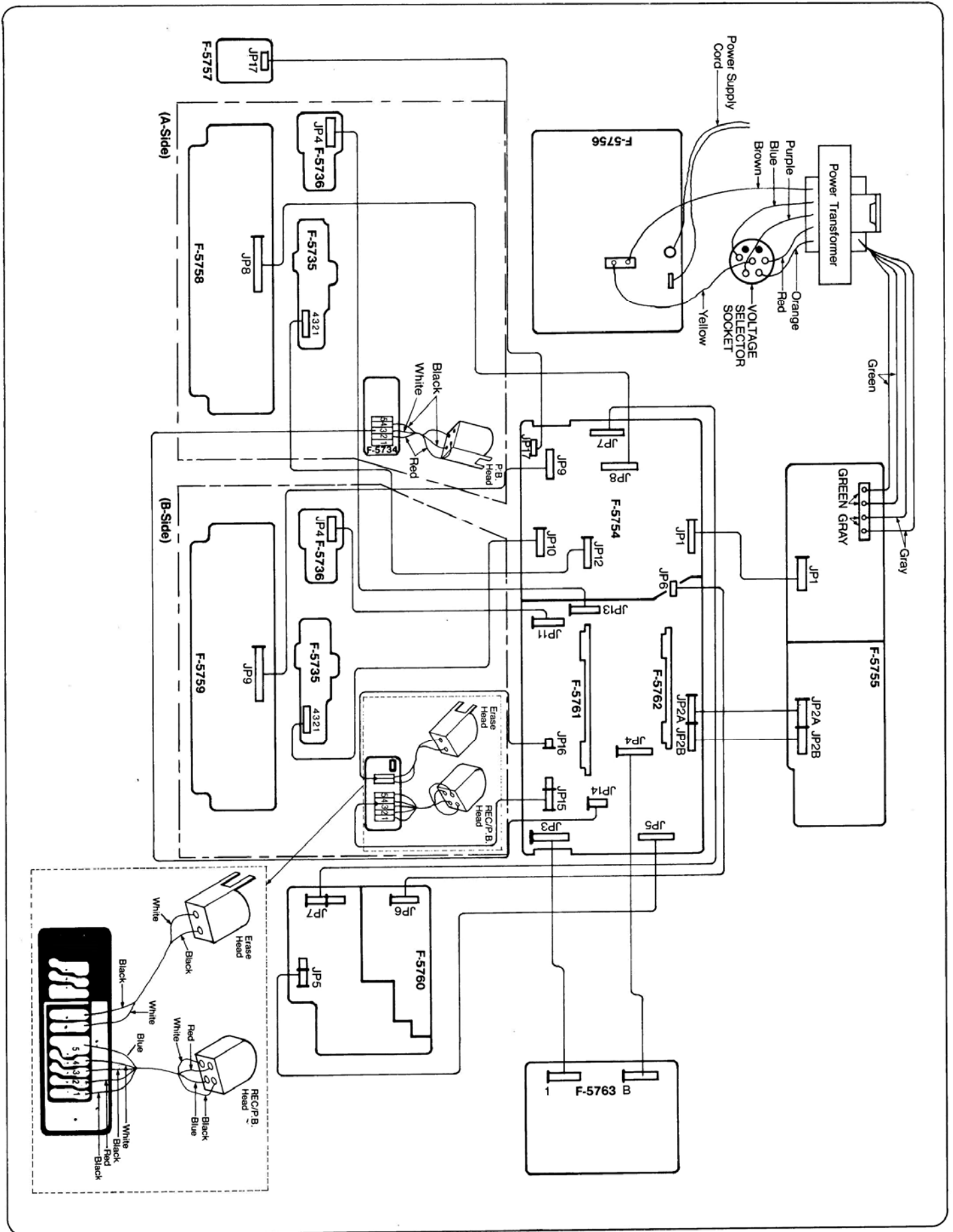

12-2 Logic Control Section

* Design and specifications subject to change without notice for improvement.
 * La présentation et les spécifications sont susceptibles d'être modifiées sans préavis par suites d'améliorations éventuelles.
 * Änderungen, die dem technischen Fortschritt dienen, bleiben vorbehalten.

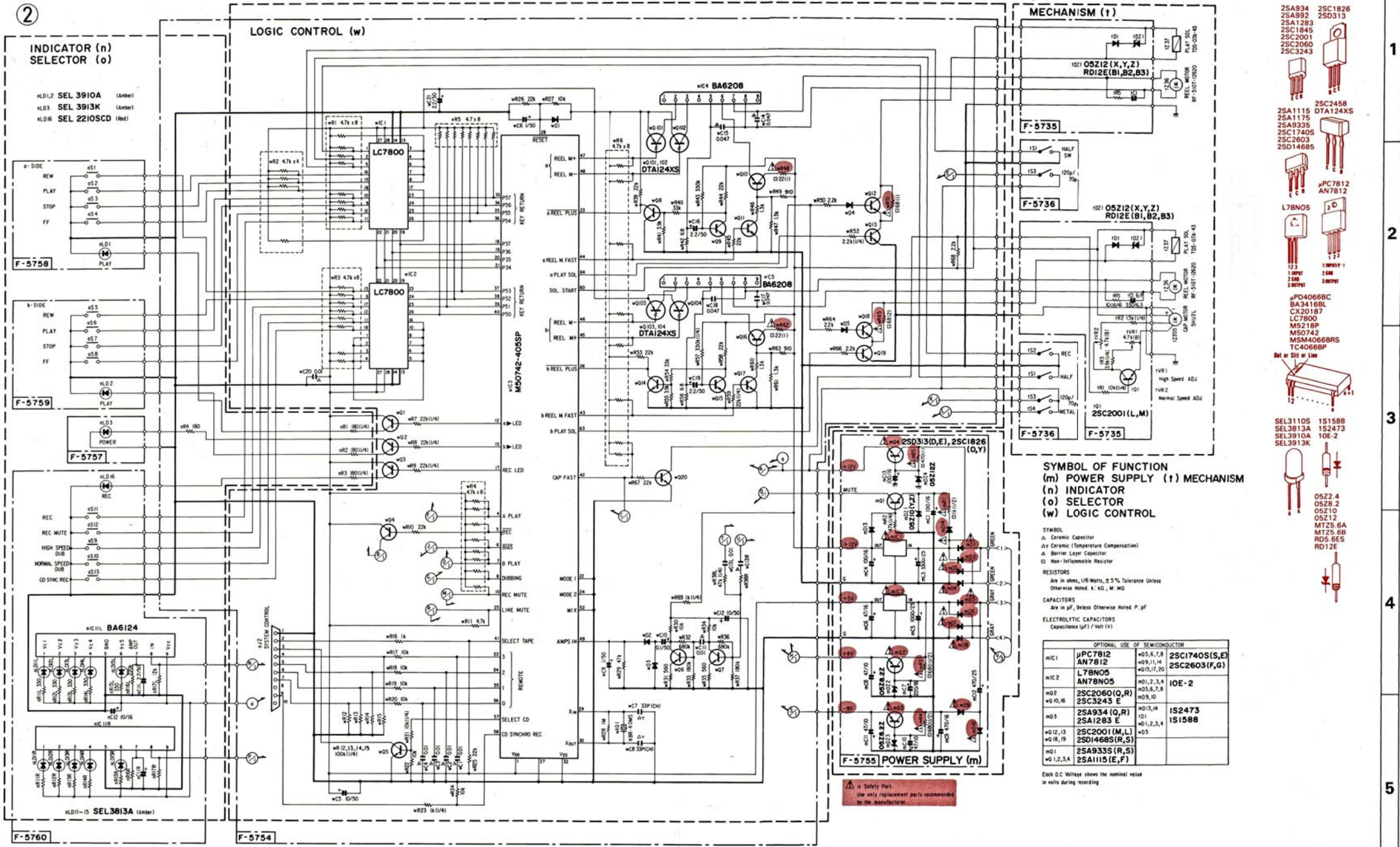

- 2SA934 2SC1826
- 2SA992 2SD0313
- 2SA1283
- 2SC1845
- 2SC2001
- 2SC2060
- 2SC2458
- 2SC3243
- 2SA1115 DTA124XS
- 2SA1175
- 2SA9335
- 2SC1740S
- 2SC2603
- 2SD1468S
- APC7812 AN7812
- L78N05
- MS218P
- MS50742
- MSM4066BRS
- TC4066BP
- Not in Stock
- SEL3110S 1S1588
- SEL3813A 1S2473
- SEL3910A IOE-2
- SEL3913K
- OS22.4
- OS26.2
- OS210
- OS212
- MT25.6A
- MT25.6B
- RD5.6S
- RD12E

SYMBOL OF FUNCTION
 (m) POWER SUPPLY (t) MECHANISM
 (n) INDICATOR
 (o) SELECTOR
 (w) LOGIC CONTROL

SYMBOL
 Δ Ceramic Capacitor
 Δv Ceramic (Temperature Compensation)
 △ Barrier Layer Capacitor
 □ Non-Infusible Resistor

RESISTORS
 Are in ohms, 1/8Watts, ±5% Tolerance Unless Otherwise Noted. K: kΩ, M: MΩ

CAPACITORS
 Are in μF, Unless Otherwise Noted. P: pF

ELECTROLYTIC CAPACITORS
 Capacitance (μF) / Volt (V)

OPTIONAL USE OF SEMICONDUCTOR		
m1C1	μPC7812 AN7812	2SC1740S(S,E) 2SC2603(F,G)
m1C2	L78N05 AN78N05	IOE-2
m2	2SC2060(O,R)	m01,2,3,4 m05,6,7,8 m09,10
m3	2SA934(O,R) 2SA1283 E	m13,14 m15 m1,2,3,4 m5
m12,13,14,15	2SC2001(M,L)	
m18,19	2SD1468S(R,S)	
m1	2SA9335(R,S) 2SA1115(E,F)	

Each D.C. Voltage shows the nominal value in volts during recording

⚠ Safety Part:
 Use only replacement parts recommended by the manufacturer.

A

B

C

D

12-3 Power Supply Section

- Design and specifications subject to change without notice for improvement.
- La présentation et les spécifications sont susceptibles d'être modifiées sans préavis par suites d'améliorations éventuelles.
- Änderungen, die dem technischen Fortschritt dienen, bleiben vorbehalten.

3

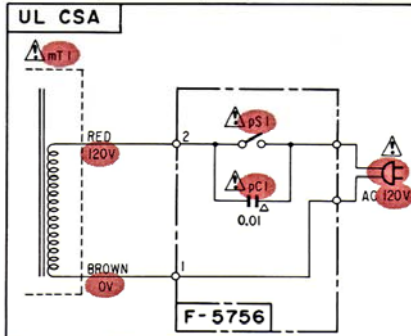
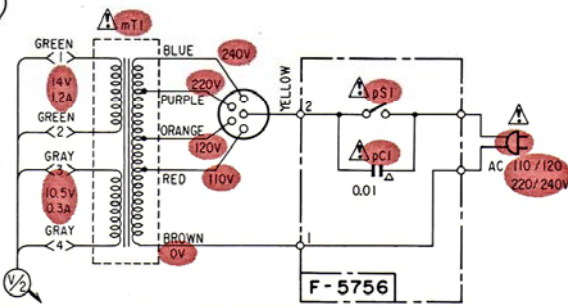

SYMBOL OF FUNCTION
 (m) POWER SUPPLY
 (p) FIXED PARTS

SYMBOL
 Δ Ceramic Capacitor
 CAPACITORS
 Are in μF Unless Otherwise Noted. P: pF

⚠ is Safety Part.
 Use only replacement parts recommended by the manufacturer.

EUROPE

UNITED KINGDOM

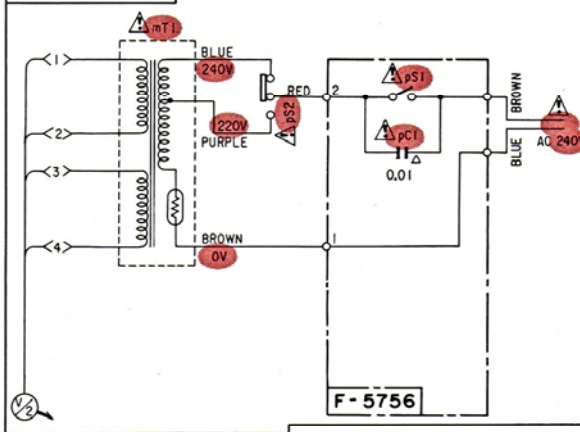
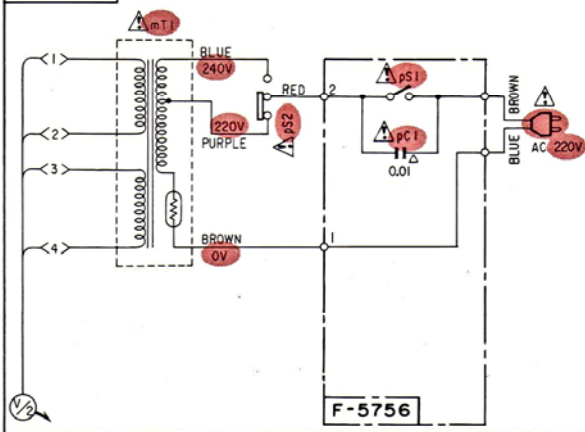

1

2

3

13. PACKING LIST

Parts No.	Stock No.	Description
1	27411500	Styfoam Packing
2	27306000	Vinyl Bag
3	27409800	Carton Case

14. ACCESSORY LIST

Stock No.	Description
46118600	PJP Cord
or 38103200	PJP Cord
or 48802200	PJP Cord
49026800	Operating Instruction (*E.F.S)
49026900	Operating Instruction (*G.I.Sw)

Note:

E·F·S: English·French· and Spanish Version
G·I·Sw: German·Italian· and Swedish Version

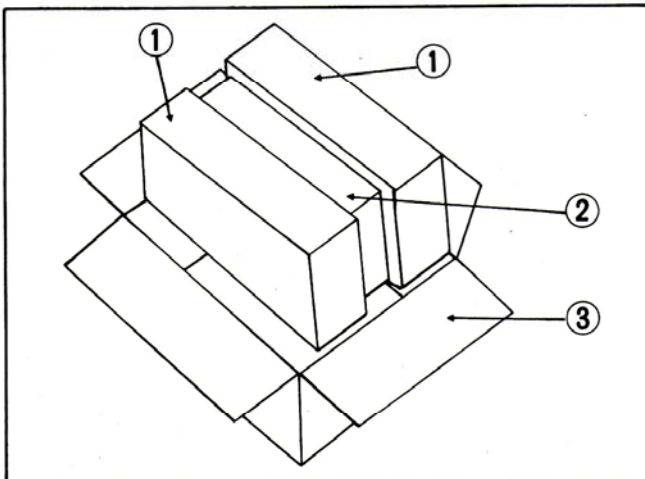

The Sansui logo is written in a stylized, italicized serif font. The letters are white and set against a solid black rectangular background.

SANSUI ELECTRIC CO., LTD.:

SANSUI ELECTRONICS CORPORATION:

SANSUI ELECTRONICS (U.K.) LTD.:
SANSUI ELECTRONICS G.M.B.H.:

14-1, Izumi 2-chome, Suginami-ku, Tokyo 168 Japan
PHONE: (03) 324-8891/TELEX: 232-2076 (International Division)

1250 Valley Brook Ave. Lyndhurst, N.J. 07071 U.S.A.
17150 South Margay Ave. Carson, California 90746 U.S.A.
3036 Koapaka Street, Honolulu, Hawaii 96819 U.S.A.

Unit 10A, Lyon Industrial Estate, Rockware Avenue, Greenford, Middx UB6, OAA, England
Paul Ehrich Strasse 8, 6074 Rödermark 2, West Germany