

# SERVICE MANUAL

STEREO CASSETTE DECK

## SANSUI D-35BF

(Silver & Black Model)



### CAUTION

1. Parts identified by the  $\Delta$  symbol on the schematic diagram and the parts list are critical for safety. Use only replacement parts that have critical characteristics recommended by the manufacturer.
2. Make leakage-current or resistance measurements to determine that exposed parts are acceptably insulated from the supply circuit before returning the appliance to the customer.

### •SPECIFICATIONS

Track format .....	4-track/2-channel system
Tape speed .....	4.8 cm/sec
<b>Heads</b>	
Rec/play head .....	HIGH-Bs hard permalloy
Erase head .....	Double-gap HIGH-Bs ferrite
Motor .....	Electronically controlled DC motor
	Reels: DC Motor
Wow/flutter .....	0.06% max (WRMS)
<b>Fast forwarding (rewinding) time</b>	
.....	Approx. 85 sec. (for C-60 tape)
<b>Frequency response</b> (—20 VU recording/playback)	
Normal Tape (LH) .....	20 to 15,000 Hz (30 to 14,000 Hz $\pm$ 3 dB)
Chrome Tape .....	20 to 16,000 Hz (30 to 15,000 Hz $\pm$ 3 dB)
Metal Tape .....	20 to 17,000 Hz (30 to 16,000 Hz $\pm$ 3 dB)
<b>Erasure rate</b> (metal tape)	
.....	70 dB min (1 kHz)
<b>Recording bias frequency</b>	
.....	85 kHz
<b>Input sensitivity/impedance</b>	
LINE IN (REC) .....	150 mV/47 kohms
MIC .....	0.5 mV/10 kohms
<b>Signal to noise ratio</b> (Record/Playback)	
Metal Tape (without Dolby Noise Reduction)	..... better than 54 dB
(With Dolby B-type Noise Reduction Effect)	..... better than 64 dB
	(above 5 kHz)
<b>Power requirements</b>	
Power voltage .....	120/220/240V (50/60 Hz)
For U.S.A. and Canada	..... 120V (60 Hz)
Power consumption .....	15 watts
<b>Dimensions</b> .....	
	430 mm (16-15/16") W
	112 mm (4-7/16") H
	224 mm (8-15/16") D
Weight .....	3.3 kg (7.3 lbs.) net

\* Design and specifications subject to changes without notice for improvements.

\* Noise reduction system manufactured under license from Dolby Laboratories Licensing Corporation.  
"Dolby" and the double D symbol are trade marks of Dolby Laboratories Licensing Corporation.

**Sansui**

SANSUI ELECTRIC CO., LTD.

## CAUTION

1. The symbols, UL, CSA, SA, BS, UK, EU, AS, XX <EXPORT> and XX-V <EXPORT(V)> on the parts list and the schematic diagram mean followings respectively.

UL..... Manufactured for U.S.A market.  
(Underwriters Laboratories approved model.)  
CSA ..... Manufactured for Canadian market.  
SA..... Manufactured for South African market.  
BS, UK..... Manufactured for United Kingdom market.  
EU ..... Manufactured for European market.  
AS..... Manufactured for Australian market.  
XX <EXPORT> ..... Standard Version with Inner Voltage Selector.  
XX-V <EXPORT(V)> .... Standard Version with Outer Voltage Selector.  
NON MARK ..... Common Parts.

2. Some printed circuit boards are not supplied as the assembled. To separate these in this service manual, the stock No's are not indicated at the ends of the board names. However, the individual parts on the circuit boards are provided by orders.

3. Since some of capacitors and resistors are omitted from parts lists in this service manual, refer to the Common Parts List for capacitors & resistors, which was issued on February 1983.

4. Abbreviations in this service manual are as follows.

### •Abbreviations List

C.R. : Carbon Resistor	E.B.L. : Low Leak Bi-Polar Electrolytic Capacitor
S.R. : Solid Resistor	Ta.C. : Tantalum Capacitor
Ce.R. : Cement Resistor	F.C. : Film Capacitor
M.R. : Metal Film Resistor	M.P. : Metalized Paper Capacitor
F.R. : Fusing Resistor	P.C. : Polystyrene Capacitor
N.I.R. : Non-Inflammable Resistor	G.C. : Gimmic Capacitor
A.R. : Array Resistor	A.C. : Array Capacitor
C.C. : Ceramic Capacitor	V.R. : Variable Resistor
C.T. : Ceramic Capacitor, Temperature Compensation	S.V.R. : Semi Variable Resistor
E.C. : Electrolytic Capacitor	SW. : Switch
E.L. : Low Leak Electrolytic Capacitor	Chip R. : Chip Resistor
E.B. : Bi-Polar Electrolytic Capacitor	Chip C. : Chip Capacitor

# 1. BLOCK DIAGRAM

## 1-1. Logic Control Section

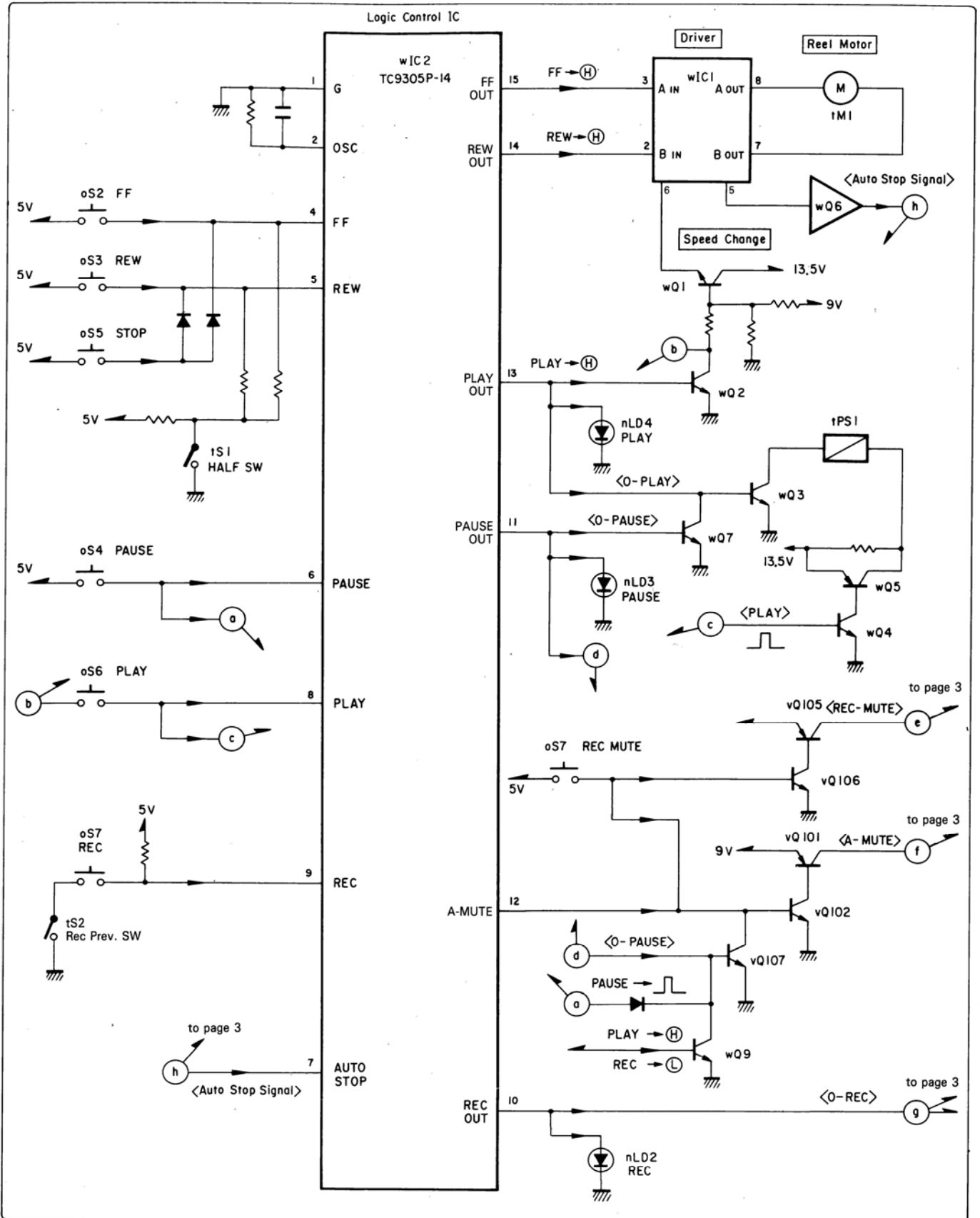

1-2. Playback Section <L-ch>

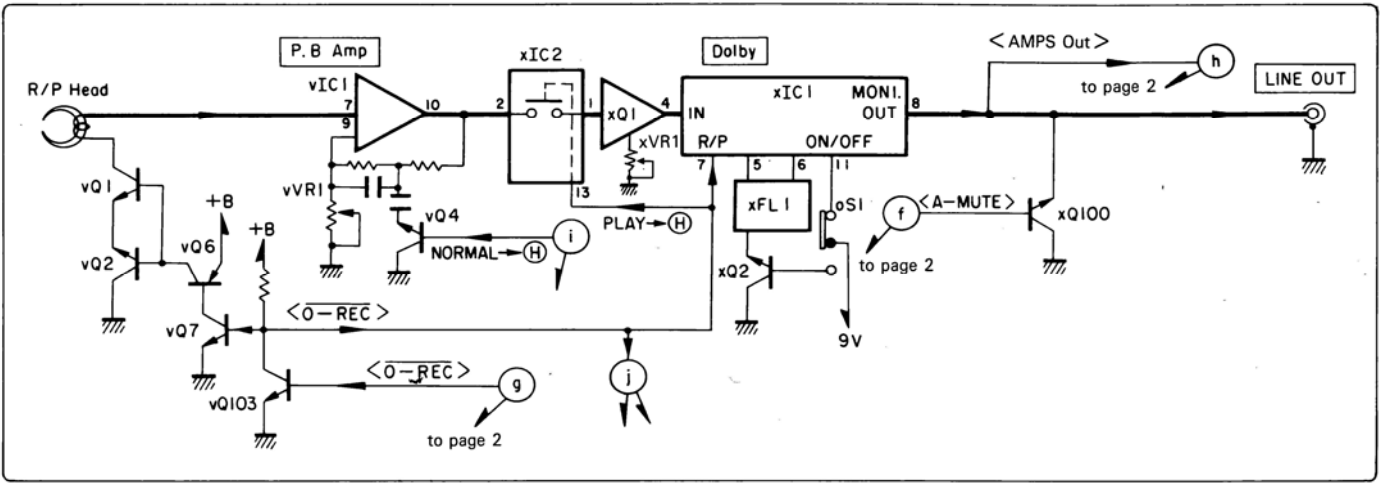

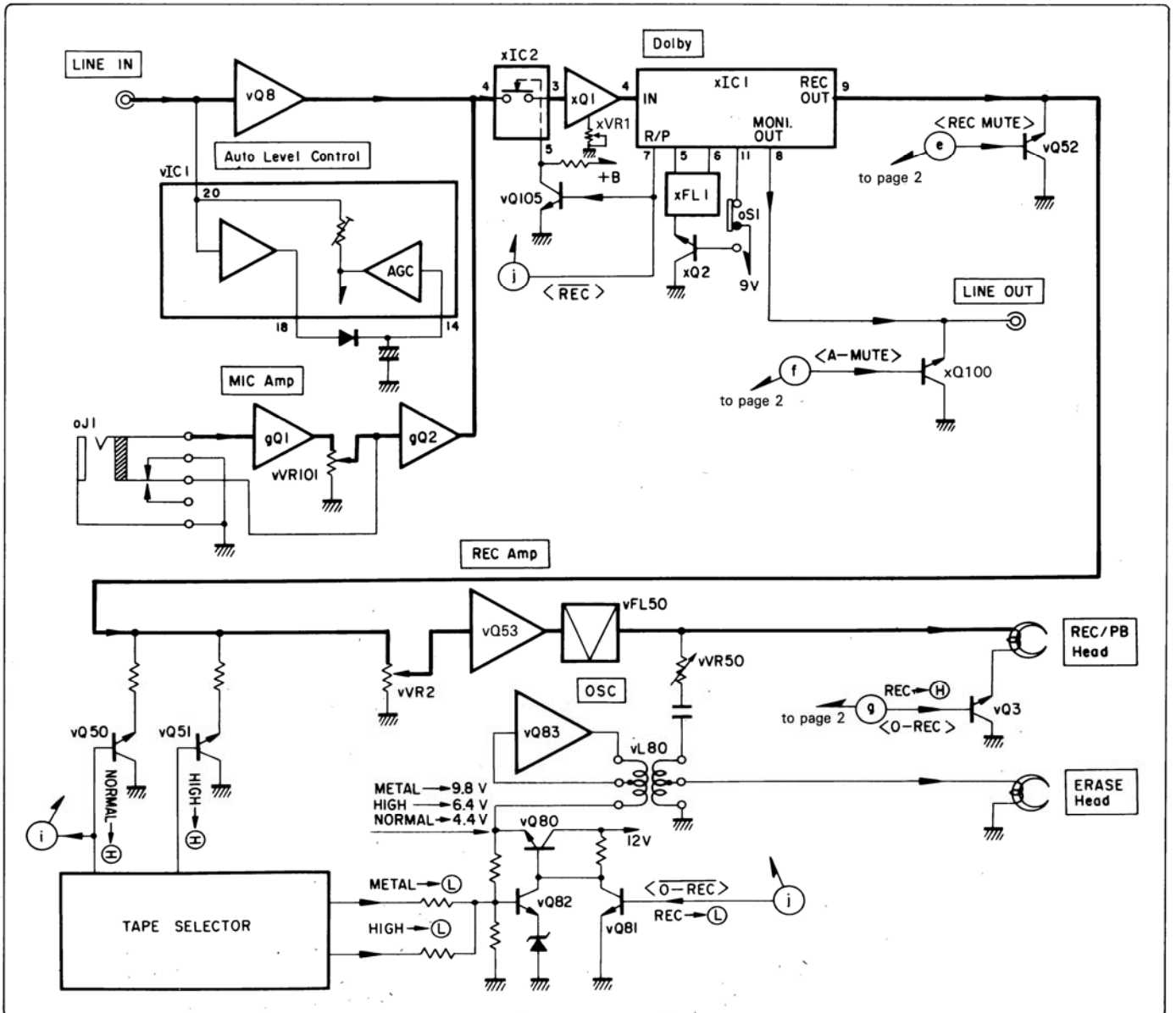

1-3. Recording Section <R-ch>



## 2. MODE OPERATION & TIMING CHART OF IC TC9305P-014

### •Mode Change Table of IC TC9305P-014 (wIC2)

PRESENT MODE \ INPUT KEY	STOP	PLAY	F.F	REW	REC	PAUSE	AUTO STOP
STOP	—	PLAY	F.F	REW	REC (-)	PAUSE	
PLAY	STOP	—	F.F	REW	—	PLAY.PAUSE	STOP
F.F	STOP	PLAY	—	REW	—	—	STOP
REW	STOP	PLAY	F.F	—	—	—	STOP
REC	STOP	—	F.F	REW	—	REC.PAUSE	STOP
PAUSE	STOP	PLAY.PAUSE	F.F	REW	REC.PAUSE (-)	STOP	
PLAY.PAUSE	STOP	—	F.F	REW	REC.PAUSE (-)	PLAY	
REC.PAUSE	STOP	—	F.F	REW	—	REC	

- Note: 1. This table shows operation when one input key is pushed on present mode.  
 2.  mark means continuing present mode.  
 3.  mark means non relation with other input ports.

### •Control IC (TC9305P-014, wIC2) Timing Chart (REC, REW→FF→STOP, FF→PLAY)

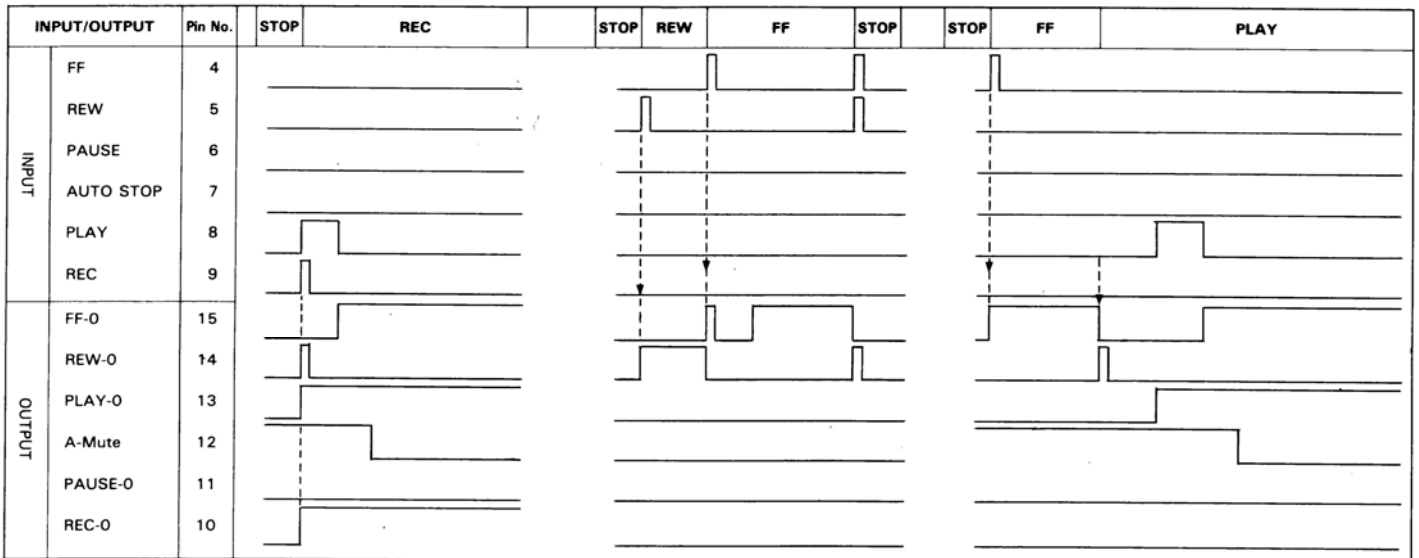



### 3. OPERATIONS OF PINCH ROLLER

#### 3-1. Torque Transportation Flowchart

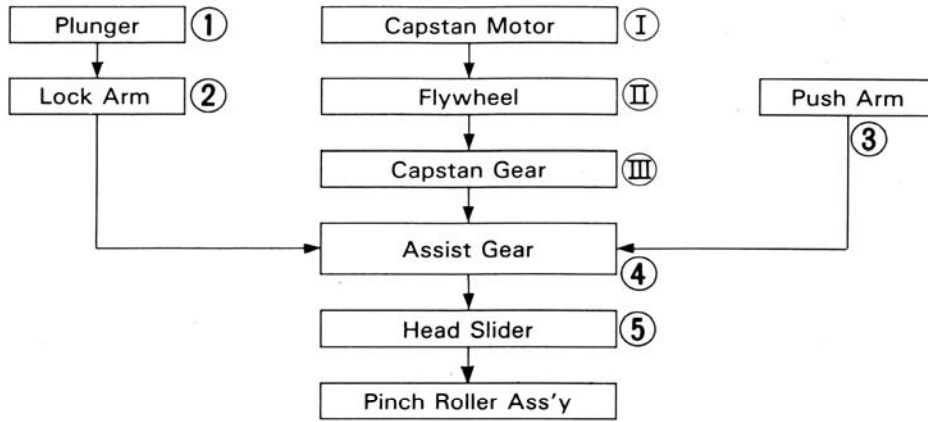

• The pinch roller is brought into pressure contact with the capstan shaft.

#### 3-2. Rear View of Mechanism Chassis

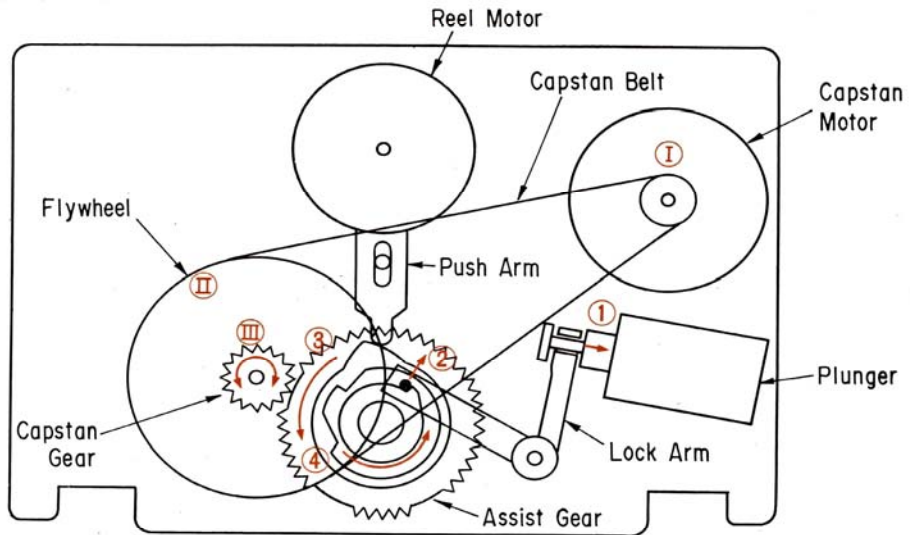

#### 3-3. Front View of Mechanism Chassis

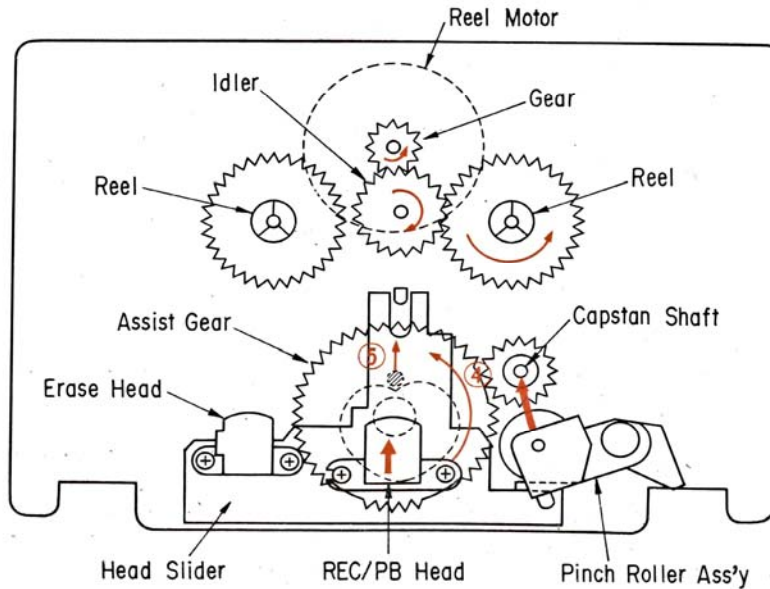

3-4. Cam Positions in the Modes of PLAY, FF, REW & STOP

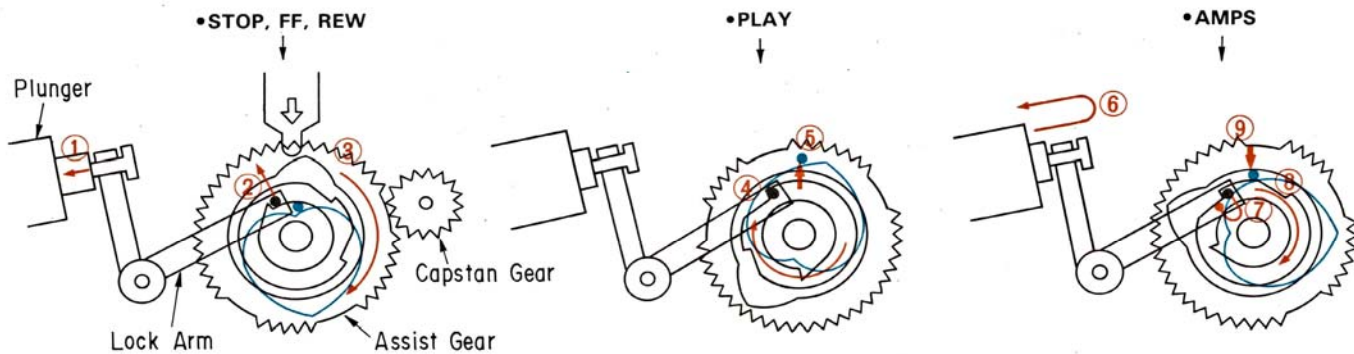

4. INTERIOR BLOCK DIAGRAM OF IC

•TA7629P (B-type DOLBY Noise Reduction IC)

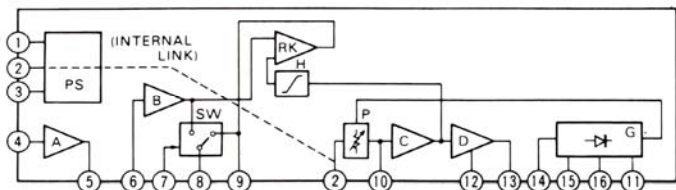

•BA6208 (Motor Drive IC)

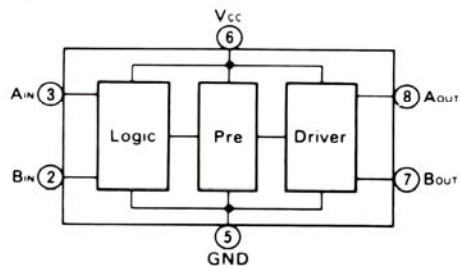

•TC4066BP/μPD4066BC (Quad Analog SW. IC)

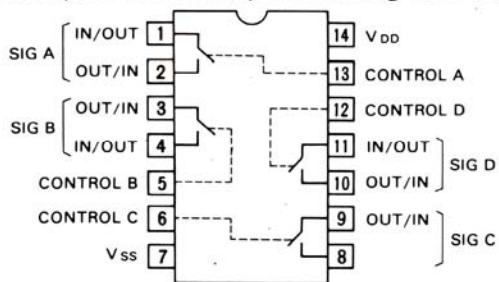

# 5. ADJUSTMENTS

## 5-1. Tape Speed Adjustment

- Note:** 1. Use Sansui Test Tape, SCT-53K (3 kHz signal is recorded on the tape).  
 2. Connections are shown in Fig. 5-1.  
 3. Remove the cassette lid. (Refer to removal of Lid Ass'y on Page 8)

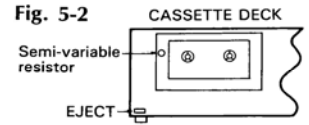
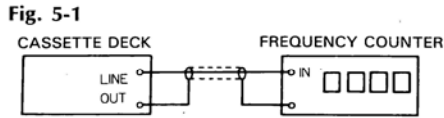

STEP	SUBJECT	MEASURE OUTPUT	SETTING	ADJUSTMENT	ADJUST FOR	REMARKS
1.	Tape Speed Adj.	LINE OUT Frequency counter	Playback the TEST TAPE SCT-53K	Turn semi-variable resistor as Fig. 5-2	3000Hz ± 45Hz	Use small screw driver

## 5-2. Playback Adjustment

- Note:** 1. Before this adjustment, clean REC/P.B. head surface.  
 2. For this adjustment, use Sansui Test Tape, SCT-F10K, and SCT-L400.  
 3. Set the Dolby NR switch to be OFF.  
 4. Connections are shown in Fig. 5-3.

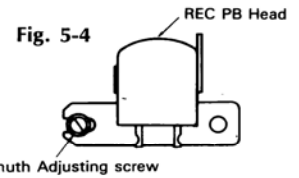
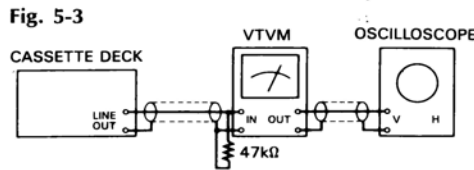

STEP	SUBJECT	MEASURE OUTPUT	SETTING	ADJUSTMENT	ADJUST FOR	REMARKS
1.	REC/P.B. Head Adj.	LINE OUT VTVM and Scope	Playback the TEST TAPE SCT-F10K	Adjust the azimuth adjusting screw in Fig. 5-4	MAX. Output both channels	Refer to removal of Lid Ass'y on Page 8. After this adjustment, lock the screw with paint.
2.	Playback Level Pre Adj.	Between Point A (L-CH) and GND/Point B (R-CH) and GND VTVM and Scope	Playback the TEST TAPE SCT-L400	Adjust each vVR1 (L-CH and R-CH, F-4945)	10mV ± 2dB	See Fig. 5-6 on Page 8.
3.	Playback or Dolby Level Adj.	LINE OUT VTVM and Scope	Playback the TEST TAPE SCT-L400	Adjust each xVR1 (L-CH and R-CH, F-4959)	320mV ± 2dB	See Top View on Page 15.

## 5-3. REC Level & Frequency Response Adjustment

- Note:** 1. Connections are shown in Fig. 5-5.  
 2. Set the Dolby NR switch to be OFF.

Fig. 5-5

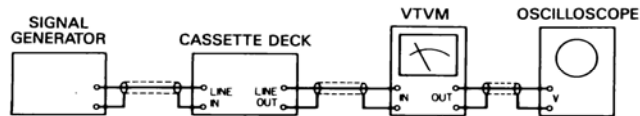

STEP	SUBJECT	INPUT SIGNAL	MEASURE OUTPUT	SETTING	ADJUSTMENT	REMARKS
1.	REC Level Adj.	Feed 1kHz, 50mV from S.G. into LINE IN.	LINE OUT VTVM and Scope	Load the TEST TAPE SCT-SA. 1. Push REC knob. 2. Playback the 1kHz signal.	Adjust vVR2 (L-CH and R-CH, F-4945) until playback level and output signal level on recording operation will be equal.	See Fig. 5-6 on Page 8.
2.	Frequency Response Adj.	Feed 1kHz 15mV and 10kHz 15mV from S.G. into LINE IN	LINE OUT VTVM and Scope	Load the TEST TAPE SCT-SA. 1. Record the 1kHz and 10kHz signals from S.G. 2. Playback the 1kHz and 10kHz signals, then confirm 10kHz signal level in less than 1kHz signal level ± 2dB on VTVM.	1. If not, adjust vVR50 (L-CH and R-CH, F-4945) slightly until the 10kHz signal level in less than 1kHz signal level ± 2dB on VTVM.	See Fig. 5-6 on Page 8.



Fig. 5-6

F-4945 < Component Side >

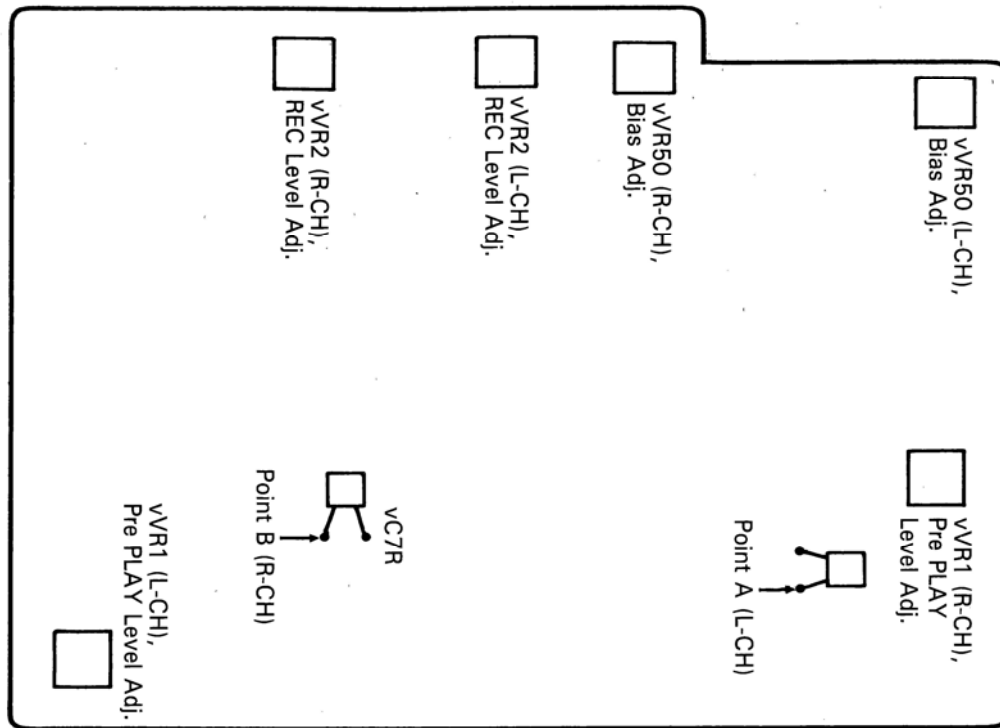

◆ List of Sansui Test Tape

Name of TEST TAPE	Recorded Frequency	Description	Equivalent To
SCT-F40	40 Hz	Playback Frequency Response Check	—
SCT-F1K	1 kHz	High Frequency Equalization Check	—
SCT-F10K	10 kHz	REC/PB Head Adjustment	—
SCT-L400N	400 Hz	Playback Level and Indicator Level Adjustment	—
SCT-S3K	3 kHz	Speed Check and Wow & Flutter Check	—
*SCT-AD (NORMAL)	—	Recording Bias Adjustment	TDK AD
*SCT-SA (HIGH)	—	REC/PB Level Adjustment	TDK SA
*SCT-MA (METAL)	—	Frequency Response Check	TDK MA

•Note: Some reference tapes marked \* are not supplied.  
As these are equivalent to ones indicated above, please obtain these blank tapes on your side as possible.

◆ Removement and Attachment of Lid Ass'y

Push EJECT Knob to open the cassette holder, push the parts locked at the left and right in the figure while pulling it upward, and remove the lid ass'y.

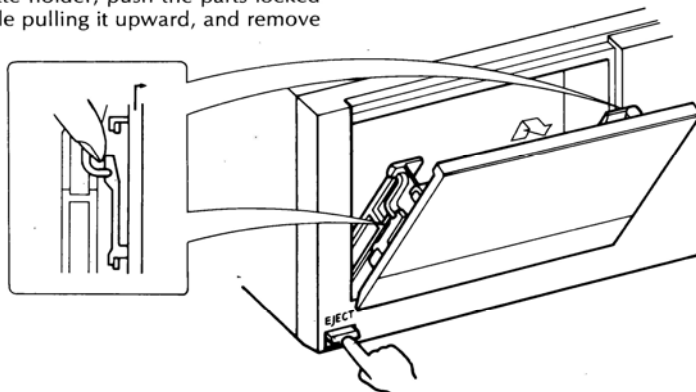

## 6. PARTS LOCATION & PARTS LIST

### 6-1. F-4832 Mic Amp. Board (Stock No. 00858601)

Component Side

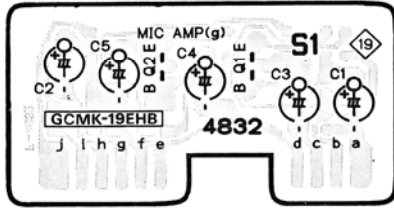

Pattern Side < Chip Parts >

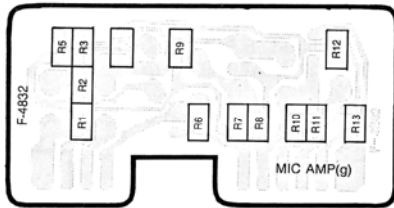

Parts List

Parts No.	Stock No.	Description
• Transistor		
gQ1	46577801	2SC2320L
	or 46581701	2SC1845
gQ2	46367101	2SC2603
	or 46367301	2SC2458
	or 48058801	2SC1740S
gR1	46750000	10kΩ 1/8W Chip R.
gR2	46752800	150kΩ 1/8W Chip R.
gR3	46754400	680kΩ 1/8W Chip R.
gR4	46750000	10kΩ 1/8W Chip R.
gR5	46741200	2.2kΩ 1/8W Chip R.
gR6	46747600	1kΩ 1/8W Chip R.
gR8	46754800	1MΩ 1/8W Chip R.
gR9	46749200	4.7kΩ 1/8W Chip R.
gR10	46752400	100kΩ 1/8W Chip R.
gR11	46750400	15kΩ 1/8W Chip R.
gR12	46750400	15kΩ 1/8W Chip R.
gR13	46747600	1kΩ 1/8W Chip R.

### 6-2. F-4961 Power Supply Board (Stock No. 00896501)

Component Side

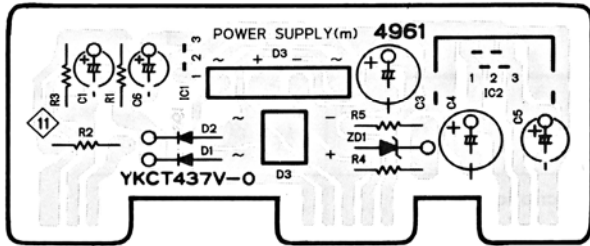

Parts List

Parts No.	Stock No.	Description
• IC		
Δ mIC1	46144200	NJM78M05A
	or 46359400	L78N05
Δ mIC2	46144500	NJM78M09A
	or 46499800	L78N09
• Diode		
Δ mD1	03117600	1S2473T77
	or 46086000	1S1588TP-3
Δ mD2	03117600	1S2473T77
	or 46086000	1S1588TP-3
Δ mD3	46273600	DBB10-B
• Zener Diode		
mDZ1	46113800	05Z12-X

### 6-3. F-4729 Cassette Half SW. Board

Component Side

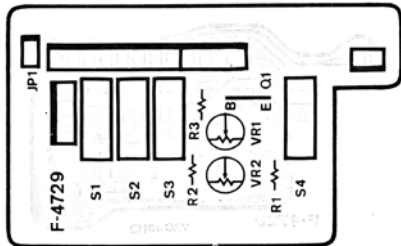

Parts List

Parts No.	Stock No.	Description
• Diode		
tD1	03111600	1S2473
tS1	47292710	Leaf SW., half
tS2	47292710	Leaf SW., rec prev.
tS3	47292710	Leaf SW., HIGH
tS4	47292710	Leaf SW., METAL

6-4. F-4943 Logic Control Board (Stock No. 00874001)  
Component Side

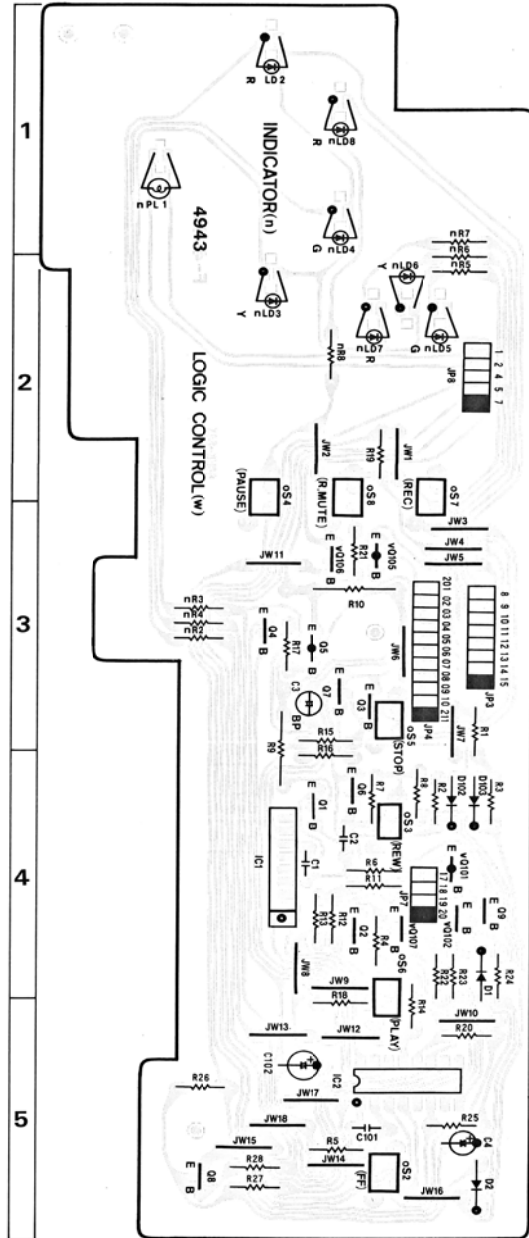

Parts No.	Stock No.	Description
•LED		
nLD2	46176900	TLS-123
	or 46470200	SEL2210S
nLD3	07251000	TLY-123
	or 46470400	SEL2910A
nLD4	07250900	TLG-123A
	or 46470300	SEL2410E
nLD5	07250900	TLG-123A
	or 46470300	SEL2410E
nLD6	07251000	TLY-123
	or 46470400	SEL2910A
nLD7	46176900	TLS-123
	or 46470200	SEL2210S
nLD8	46176900	TLS-123
	or 46470200	SEL2210S
nPL1	48191900	Pilot Lamp 12V 0.15A
oS2	46396700	Push SW., F.FWD
oS3	46396700	Push SW., REW
oS4	46396700	Push SW., PAUSE
oS5	46396700	Push SW., STOP
oS6	46396700	Push SW., PLAY
oS7	46396700	Push SW., REC
oS8	46396700	Push SW., REC MUTE
•Transistor		
vQ101	46719800	DTA124ES
vQ102	46367101	2SC2603
	or 46367301	2SC2458
	or 48058801	2SC1740S
vQ105	46719800	DTA124ES
vQ106	46367101	2SC2603
	or 46367301	2SC2458
	or 48058801	2SC1740S
vQ107	46367101	2SC2603
	or 46367301	2SC2458
	or 48058801	2SC1740S
ΔwQ1	46614101	2SC3243
wQ2	46367101	2SC2603
	or 46367301	2SC2458
	or 48058801	2SC1740S
wQ3	46359801	2SC2001
	or 46614101	2SC3243
	or 48055901	2SD1468S
wQ4	46367101	2SC2603
	or 46367301	2SC2458
	or 48058801	2SC1740S
ΔwQ5	46359701	2SA952
ΔwQ6	46614001	2SA1283
wQ7	46367101	2SC2603
	or 46367301	2SC2458
wQ8	46367101	2SC2603
	or 48058801	2SC1740S
wQ9	46367101	2SC2603
	or 46367301	2SC2458
	or 48058801	2SC1740S
•IC		
wIC1	46149600	BA6208
wIC2	48074900	TC9305P-014
ΔwR9	46248900	47Ω 1W N.I.R.
ΔwR10	46249200	82Ω 1W N.I.R.
•Diode		
wD1	03117600	1S2473T77
	or 46086000	1S1588TP-3

6-5. F-4944 input & Output Terminal Board (Stock No. 00873901)  
Component Side

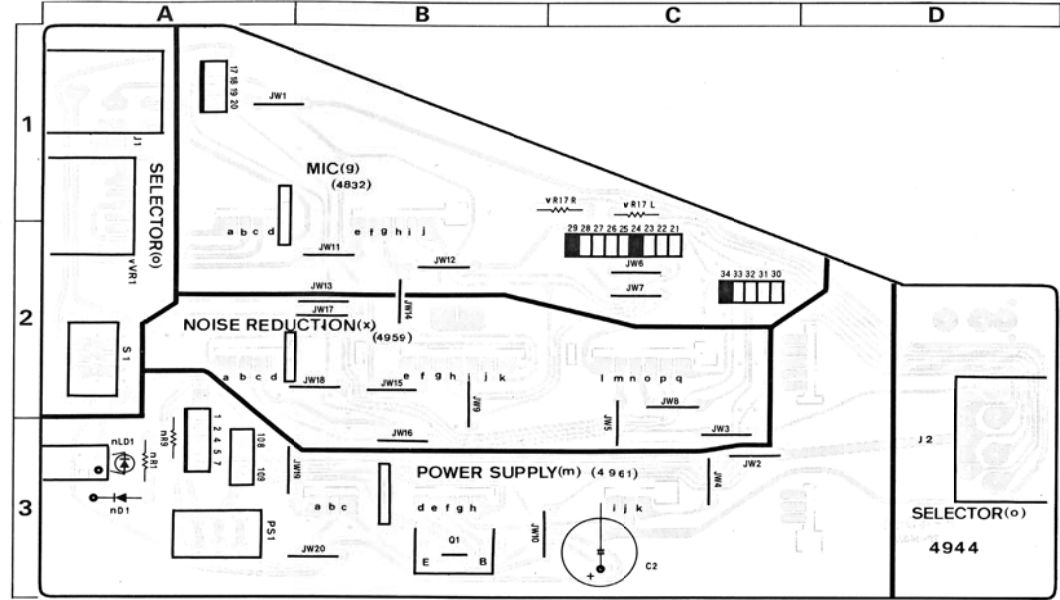

Parts No.	Stock No.	Description	Parts No.	Stock No.	Description
wD2	03117600	1S2473T77	wD103	03117600	1S2473T77
	or 46086000	1S1588TP-3		or 46086000	1S1588TP-3
wD102	03117600	1S2473T77	wC3	08450800	3.3μF 16V E.B.
	or 46086000	1S1588TP-3	wC101	46695400	0.012μF 50V F.C.
•Transistor			ΔnR9	46227800	10Ω 1/2W N.I.R.
ΔmQ1	03086101	2SD357	oS1	46533500	Slide SW., DOLBY NR
•Diode			oJ1	24306100	Jack, MIC
ΔnD1	03117600	1S2473T77	oJ2	46371500	4P Terminal, LINE OUT
Δ	or 46086000	1S1588TP-3	ΔpS1	48172700	Push SW., POWER
•LED			vVR101	48172800	50K V.R., MIC LEVEL
nLD1	46176900	TLS-123			
	or 46470200	SEL2210S			

6-6. F-4945 REC & PLAY Amp. Board (Stock No. 00872901)

Component Side

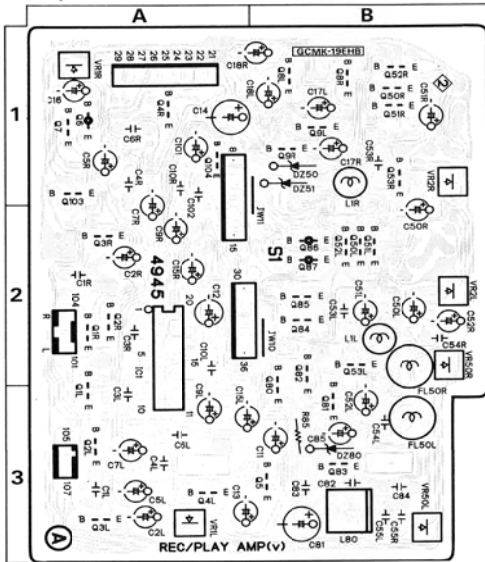

Pattern Side <Chip Parts>

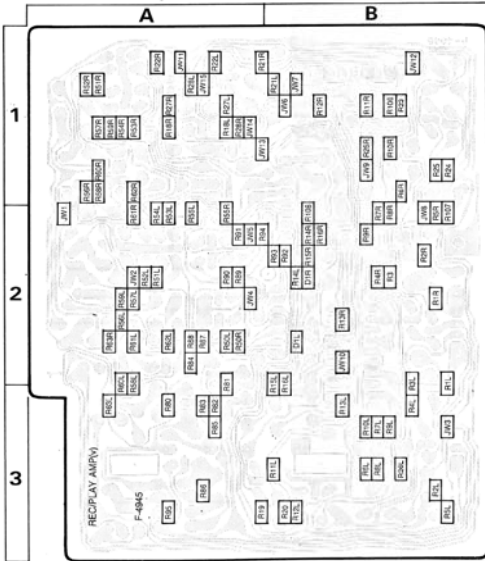

Parts List

Parts No.	Stock No.	Description
•Transistor		
vQ1	46581701	2SC1845
vQ2	46581701	2SC1845
vQ3	46359801	2SC2001
	or 48055901	2SD1468S
vQ4	46367101	2SC2603
	or 46367301	2SC2458
	or 48058801	2SC1740S
vQ5	46367101	2SC2603
	or 46367301	2SC2458
	or 48058801	2SC1740S
vQ6	46719800	DTA124ES
vQ7	46367101	2SC2603
	or 46367301	2SC2458
	or 48058801	2SC1740S
vQ8	46367101	2SC2603
	or 46367301	2SC2458
	or 48058801	2SC1740S
vQ9	46367101	2SC2603
	or 46367301	2SC2458
	or 48058801	2SC1740S
vQ50	46367101	2SC2603
	or 46367301	2SC2458
	or 48058801	2SC1740S
vQ51	46367101	2SC2603
	or 46367301	2SC2458
	or 48058801	2SC1740S
vQ52	46367101	2SC2603
	or 46367301	2SC2458
	or 48058801	2SC1740S
vQ53	46367101	2SC2603
	or 46367301	2SC2458
	or 48058801	2SC1740S
vQ80	46614101	2SC3243
vQ81	46367101	2SC2603
	or 46367301	2SC2458
	or 48058801	2SC1740S
vQ82	46367101	2SC2603
	or 46367301	2SC2458
	or 48058801	2SC1740S
vQ83	48061801	2SC3244
vQ84	46367101	2SC2603
	or 46367301	2SC2458
	or 48058801	2SC1740S
vQ85	46367101	2SC2603
	or 46367301	2SC2458
	or 48058801	2SC1740S
vQ86	46367001	2SA1115
	or 46392001	2SA1175
	or 48058901	2SA933S
vQ87	46367001	2SA1115
	or 46392001	2SA1175
	or 48058901	2SA933S
vQ103	46367101	2SC2603
	or 46367301	2SC2458
	or 48058801	2SC1740S
vQ104	46367101	2SC2603
	or 46367301	2SC2458
	or 48058801	2SC1740S
•IC		
vIC1	46362100	M51161P
•Diode		
vD1	46852000	RLS-73 (Chip)
•Zener Diode		
vDZ50	46111100	05Z5.1-X
	or 46111200	05Z5.1-Y
	or 46111300	05Z5.1-Z
vDZ51	46111100	05Z5.1-X
	or 46111200	05Z5.1-Y
	or 46111300	05Z5.1-Z
vDZ80	46109400	05Z3.0-Y

Parts List <F-4945>

Parts No.	Stock No.	Description
vJW1	46741100	Cross Conductor (Chip)
vJW2	46741100	Cross Conductor (Chip)
vJW3	46741100	Cross Conductor (Chip)
vJW4	46741100	Cross Conductor (Chip)
vJW5	46741100	Cross Conductor (Chip)
vJW6	46741100	Cross Conductor (Chip)
vJW7	46741100	Cross Conductor (Chip)
vJW8	46741100	Cross Conductor (Chip)
vJW9	46741100	Cross Conductor (Chip)
vJW10	46741100	Cross Conductor (Chip)
vJW11	46741100	Cross Conductor (Chip)
vJW12	46741100	Cross Conductor (Chip)
vJW13	46741100	Cross Conductor (Chip)
vJW14	46741100	Cross Conductor (Chip)
vJW15	46741100	Cross Conductor (Chip)
vR1	46742800	10Ω 1/8W Chip R.
vR2	46751800	56kΩ 1/8W Chip R.
vR3	46750400	15kΩ 1/8W Chip R.
vR4	46748800	3.3kΩ 1/8W Chip R.
vR5	46748400	2.2kΩ 1/8W Chip R.
vR6	46745600	390Ω 1/8W Chip R.
vR7	46748400	2.2kΩ 1/8W Chip R.
vR8	46752600	120kΩ 1/8W Chip R.
vR9	46750400	15kΩ 1/8W Chip R.
vR10	46745200	270Ω 1/8W Chip R.
vR11	46753200	220kΩ 1/8W Chip R.
vR12	46750800	22kΩ 1/8W Chip R.
vR13	46745100	91Ω 1/8W Chip R.
vR14	46748400	2.2kΩ 1/8W Chip R.
vR15	46747400	820Ω 1/8W Chip R.
vR16	46746200	270Ω 1/8W Chip R.
vR18	46749000	3.9kΩ 1/8W Chip R.
vR19	46750800	22kΩ 1/8W Chip R.
vR20	46748400	2.2kΩ 1/8W Chip R.
vR21	46749200	4.7kΩ 1/8W Chip R.
vR22	46753200	220kΩ 1/8W Chip R.
vR23	46747600	1kΩ 1/8W Chip R.
vR24	46750800	22kΩ 1/8W Chip R.
vR25	46750800	22kΩ 1/8W Chip R.
vR26	46750000	10kΩ 1/8W Chip R.
vR27	46749200	4.7kΩ 1/8W Chip R.
vR28	46750000	10kΩ 1/8W Chip R.
vR50	46749200	4.7kΩ 1/8W Chip R.
vR51	46749600	6.8kΩ 1/8W Chip R.
vR52	46750400	15kΩ 1/8W Chip R.
vR53	46750000	10kΩ 1/8W Chip R.
vR54	46750000	10kΩ 1/8W Chip R.
vR55	46749200	4.7kΩ 1/8W Chip R.
vR56	46750000	10kΩ 1/8W Chip R.
vR57	46749800	8.2kΩ 1/8W Chip R.
vR58	46754400	680kΩ 1/8W Chip R.
vR59	46753400	270kΩ 1/8W Chip R.
vR60	46750400	15kΩ 1/8W Chip R.
vR61	46747600	1kΩ 1/8W Chip R.
vR62	46744000	33Ω 1/8W Chip R.
vR63	46748400	2.2kΩ 1/8W Chip R.
vR80	46750000	10kΩ 1/8W Chip R.
vR81	46747600	1kΩ 1/8W Chip R.
vR82	46747200	680Ω 1/8W Chip R.
vR83	46749200	4.7kΩ 1/8W Chip R.
vR84	46750800	22kΩ 1/8W Chip R.
vR85	46742800	10Ω 1/8W Chip R.
vR86	46750000	10kΩ 1/8W Chip R.
vR87	46749800	8.2kΩ 1/8W Chip R.
vR88	46748800	3.3kΩ 1/8W Chip R.
vR89	46750800	22kΩ 1/8W Chip R.
vR90	46750800	22kΩ 1/8W Chip R.
vR91	46752400	100kΩ 1/8W Chip R.
vR92	46748400	2.2kΩ 1/8W Chip R.
vR93	46748400	2.2kΩ 1/8W Chip R.
vR94	46752400	100kΩ 1/8W Chip R.
vR95	46742000	4.7Ω 1/8W Chip R.

Parts No.	Stock No.	Description
vR106	46747600	1kΩ 1/8W Chip R.
vR107	46751600	47kΩ 1/8W Chip R.
vR108	46747600	1kΩ 1/8W Chip R.
vC84	46657000	3900pF 100V F.C.
vFL50	42904400	Peaking Coil
vL1	48121500	Inductor 2.7mH
vL80	46362200	Bias OSC Coil
vVR1	48078400	470Ω S.V.R., Pre PLAY Level Adj.
vVR2	48079600	47kΩ S.V.R., REC Level Adj.
vVR50	48079800	100kΩ S.V.R., Bias Adj.

6-7. F-4916 Fuse Board

Component Side

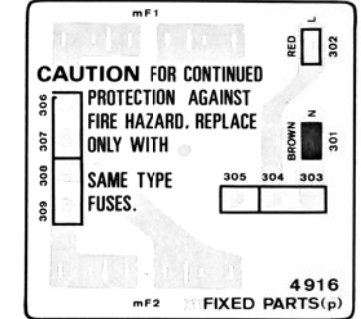

Parts List

Parts No.	Stock No.	Description
ΔmF1	07184600	Fuse 800mA (EU,BS,AS)

6-8. F-4959 Noise Reduction Board (Stock No. 00873001)  
Component Side

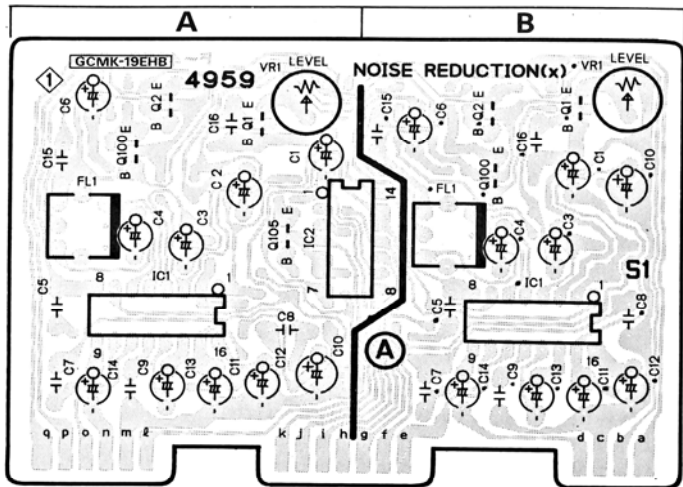

Pattern Side <Chip Parts>

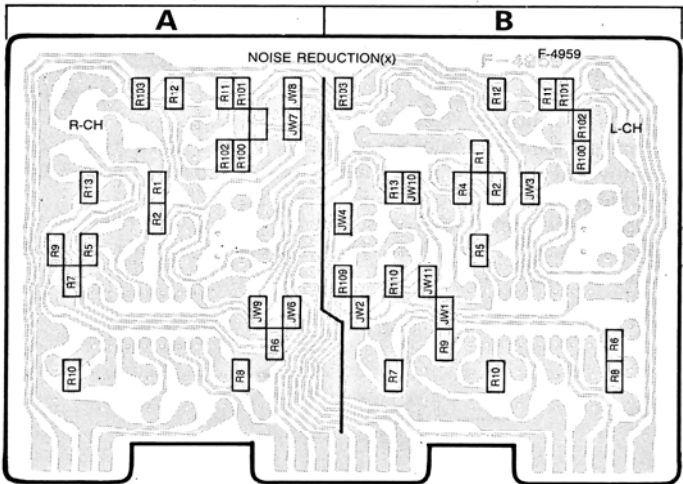

•Note: On this circuit board, the left channel is specified by "●" mark on top of the parts No.

Parts List

Parts No.	Stock No.	Description
•Transistor		
xQ1	46367101 or 46367301 or 48058801	2SC2603 2SC2458 2SC1740S
xQ2	46367101 or 46367301 or 48058801	2SC2603 2SC2458 2SC1740S
xQ100	46367101 or 46367301 or 48058801	2SC2603 2SC2458 2SC1740S
xQ105	46367101 or 46367301 or 48058801	2SC2603 2SC2458 2SC1740S
•IC		
xIC1	46128200	TA7629P
xIC2	07224800 or 46421000 or 48054500 or 48063800	TC4066BP $\mu$ PD4066BC MSM4066BRS BU4066B
xJW1	46741100	Cross Conductor (Chip)
xJW2	46741100	Cross Conductor (Chip)
xJW3	46741100	Cross Conductor (Chip)
xJW4	46741100	Cross Conductor (Chip)
xJW6	46741100	Cross Conductor (Chip)
xJW7	46741100	Cross Conductor (Chip)
xJW8	46741100	Cross Conductor (Chip)
xJW9	46741100	Cross Conductor (Chip)
xJW10	46741100	Cross Conductor (Chip)
xJW11	46741100	Cross Conductor (Chip)
xR1	46753200	220k $\Omega$ 1/8W Chip R.
xR2	46748400	2.2k $\Omega$ 1/8W Chip R.
xR4	46747200	680 $\Omega$ 1/8W Chip R.
xR5	46752400	100k $\Omega$ 1/8W Chip R.
xR6	46745800	180 $\Omega$ 1/8W Chip R.
xR7	46748800	3.3k $\Omega$ 1/8W Chip R.
xR8	46751600	47k $\Omega$ 1/8W Chip R.
xR9	46752800	150k $\Omega$ 1/8W Chip R.
xR10	46753400	270k $\Omega$ 1/8W Chip R.
xR11	46750000	10k $\Omega$ 1/8W Chip R.
xR12	46754800	1M $\Omega$ 1/8W Chip R.
xR13	46751600	47k $\Omega$ 1/8W Chip R.
xR100	46748600	2.7k $\Omega$ 1/8W Chip R.
xR101	46748400	2.2k $\Omega$ 1/8W Chip R.
xR102	46749200	4.7k $\Omega$ 1/8W Chip R.
xR103	46748400	2.2k $\Omega$ 1/8W Chip R.
xR109	46750000	10k $\Omega$ 1/8W Chip R.
xR110	46751600	47k $\Omega$ 1/8W Chip R.
xFL1	46177500 or 46177501	DOLBY Filter DOLBY Filter
xVR1	46633700	1k $\Omega$ (B) S.V.R., PLAY or Dolby Level Adj.



## 7. MAIN PARTS REPLACEMENT (See Exploded View on page 14)

### A. Bonnet (See Fig. 7-1)

- 1) Remove two screws (S<sub>A</sub>).
- 2) Push the rear side of the bonnet to remove the hooks and then remove bonnet.

Fig. 7-1

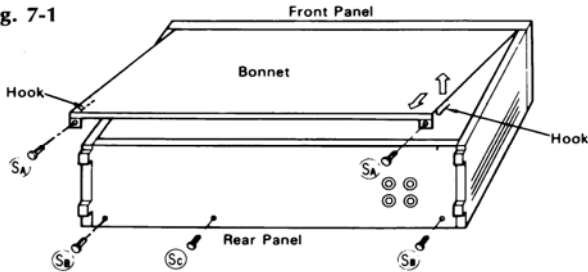

### B. Bottom Plate

- 1) Remove two screws (S<sub>B</sub>) (See Fig. 7-1).
  - 2) Push the rear side of the bottom plate to remove the hooks and then remove bonnet.
- \* Install the bottom plate after matching eject spring with Point (A) of bottom plate. (See Fig. 7-2)

Fig. 7-2

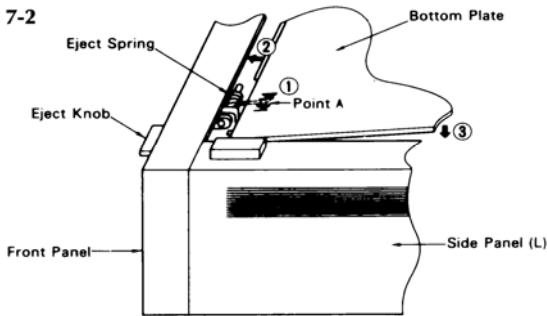

### C. Side Panel L (R) (See Fig. 7-3)

- 1) Remove bonnet and bottom plate.
- 2) Shift the position of the side panel L (R) 1.5 cm in to the arrow direction (1).
- 3) Remove the hooks (2) of the side panel from front panel and then pull it to the arrow direction (3) to remove the side panel L (R).

Fig. 7-3

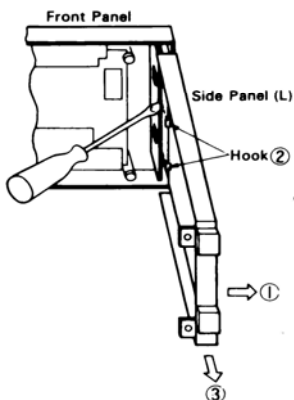

### D. Mechanism Ass'y

- 1) Remove bonnet and bottom plate.
- 2) Extract five connectors.
- 3) Take off counter belt around the counter pulley.
- 4) Loosen four screws to remove mechanism Ass'y.
- 5) Push the eject knob to open cassette holder.
- 6) Take out the mechanism Ass'y.

**Note:** To attach the mechanism Ass'y, put the counter belt at the reel groove and insert the damper shaft into the pipe of damper first.

### E. Rec/PB Head (20)

- 1) Remove the mechanism ass'y from set.
- 2) Unsolder head read wires.
- 3) Loosen two screws.

### F. Pinch Roller Ass'y (4)

- 1) Remove the mechanism ass'y from set.
- 2) Pull out the lock pin (3).
- 3) Take out the pinchroller ass'y.

### G. Reel Gear Ass'y (17)

- 1) Remove the mechanism ass'y from set.
- 2) Take off two washer (15), (16) to pull out reel gear.

### H. Capstan Motor (31), Reel Motor (32), Capstan Belt (27), Flywheel (28), Plunger Solenoid (37)

- 1) Remove the mechanism ass'y from set.
- 2) Extract two connectors on the F-4945 circuit board.
- 3) Remove the F-4945 circuit board from the mechanism Ass'y.
- 4) Take out shield plate (24).
- 5) Loosen four screws (25) fastening sub chassis (26).

### I. Damper Ass'y

- 1) Hold the damper holder to fix it, and push the damper ass'y to the arrow direction as Fig. 7-4. so that the damper ass'y is removed from the damper holder. (See Fig. 7-4)
- 2) Pinch the joint portion of the joint shaft and the damper ass'y, and remove the joint shaft from the groove of the damper holder after a little twist to the left. (See Fig. 7-5)
- 3) Turn up the damper end, to set the slit of the damper ass'y to the projection of the joint shaft. Then pull out the damper ass'y from the joint shaft. (See Fig. 7-6)

Fig. 7-4

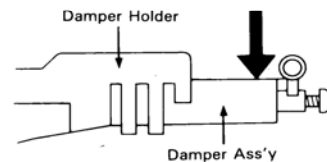

Fig. 7-5

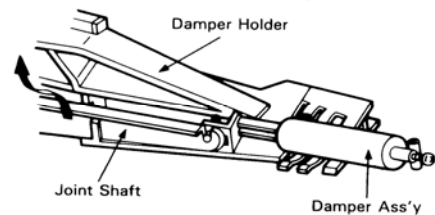
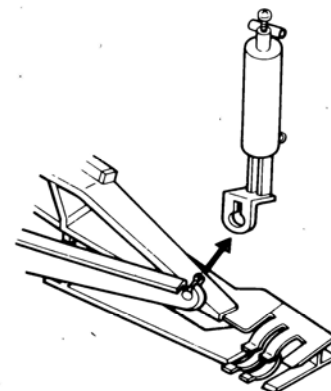

Fig. 7-6



## 8. EXPLODED VIEW OF MECHANISM ASS'Y & PARTS LIST

8-1. Front View of Mechanism Chassis

• Though every part included in mechanism ass'y is numbered in exploded view, parts unlisted in the parts list are not supplied.

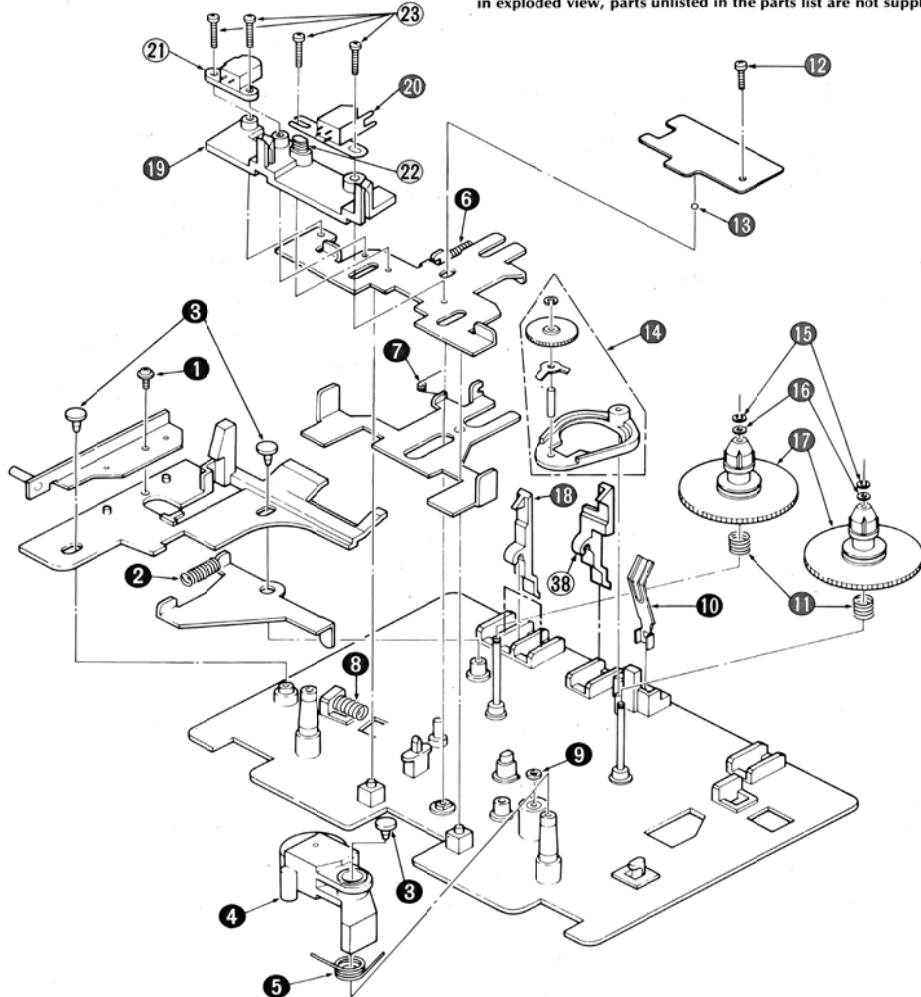

**Parts List**

Parts No.	Stock No.	Description
1	46267900	Tapping Screw, M3.0×8
2	47644500	Spring, eject
3	47420900	Plastic Tack
4	47281810	Pinch Roller Ass'y
5	47483100	Spring, pinch roller
6	47406200	Spring, head base
7	47405600	Spring, slide base
8	47668600	Spring, plunger solenoid
9	47404700	Washer, d = 2.5
10	47293510	Spring, half

Parts No.	Stock No.	Description
11	47709610	Spring, reel
12	13127800	Tapping Screw, M2×12
13	47404900	Steel Ball, φ2.0
14	47405000	Arm Ass'y
15	47404800	Washer, d = 1.6
16	47487100	Washer, d = 2.0
17	47835500	Reel Gear Ass'y
18	47723010	Sensor Arm (A)
19	47284110	Head Base
20	48001600	REC/PB Head

8-2. Rear View of Mechanism Chassis

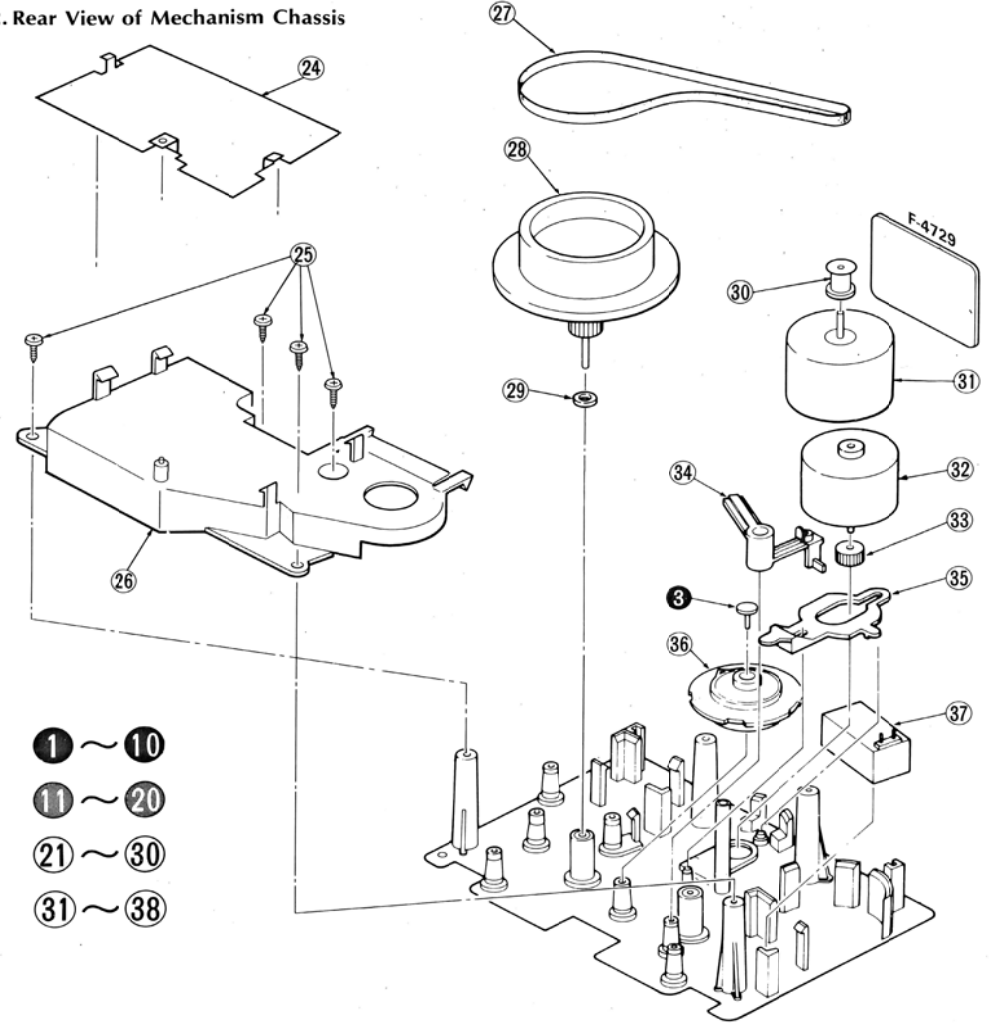

- 1 ~ 10
- 11 ~ 20
- 21 ~ 30
- 31 ~ 38

Parts No.	Stock No.	Description
21	07997400	Erase Head
22	47406100	Spring azimuth
23	00420900	Binding Head Screw, M2×12
24		Shield Plate
25	46267800	Pan Head Tapping Screw, M3×8
26	47658030	Sub Chassis
27	47405100	Belt
28	47598100	Flywheel Ass'y
29	47404600	Washer, d = 2.5
30	47283200	Pully

Parts No.	Stock No.	Description
31	46737400	Capstan Motor
32	46737500	Reel Motor
33	47293110	Gear, reel motor
34	47281610	Lock Arm
35	47293810	Arm (B)
36	47283830	Assist Gear
37	47292610	Plunger Solenoid
38	47292520	Sensor Arm B

## 9. OTHER PARTS

### 9-1. Front View

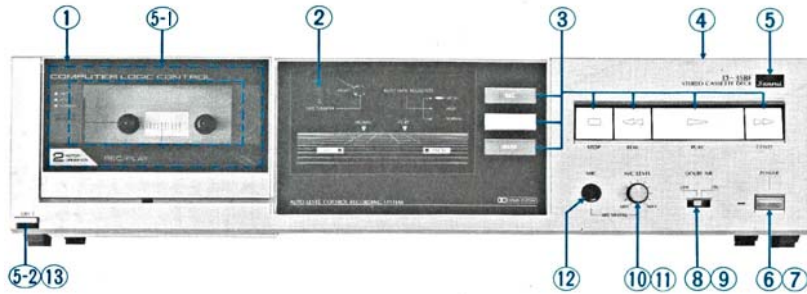

Parts List < Front View >

Parts No.	Stock No.	Description
1	47768900	Cassette Lid Ass'y < Silver Model >
	47769000	Cassette Lid Ass'y < Black Model >
2	48173000	Tape Counter
3	46396700	Push SW., REW, F.FWD, PLAY, REC, STOP, PAUSE, REC MUTE
4	47823500	Bonnet < Silver Model >
	47874700	Bonnet < Black Model >
5	47769100	Front Panel Ass'y < Silver Model >
	47769200	Front Panel Ass'y < Black Model >
5-1	47678700	Cassette Holder Ass'y
5-2	47776100	Knob, EJECT < Silver Model >
	47776200	Knob, EJECT < Black Model >
6	47747000	Push Knob, POWER < Silver Model >
	47747100	Push Knob, POWER < Black Model >
Δ 7	48172700	Push SW., POWER
8	47778800	Slide Knob, DOLBY NR < Silver Model >
	47800700	Slide Knob, DOLBY NR < Black Model >
9	46533500	Slide SW., DOLBY NR
10	47794600	Knob, MIC LEVEL < Silver Model >
	07895410	Knob, MIC LEVEL < Black Model >
11	48172800	50kΩ V.R., MIC LEVEL
12	24306100	Jack, MIC
13	47673000	Spring, EJECT

### 9-2. Top View

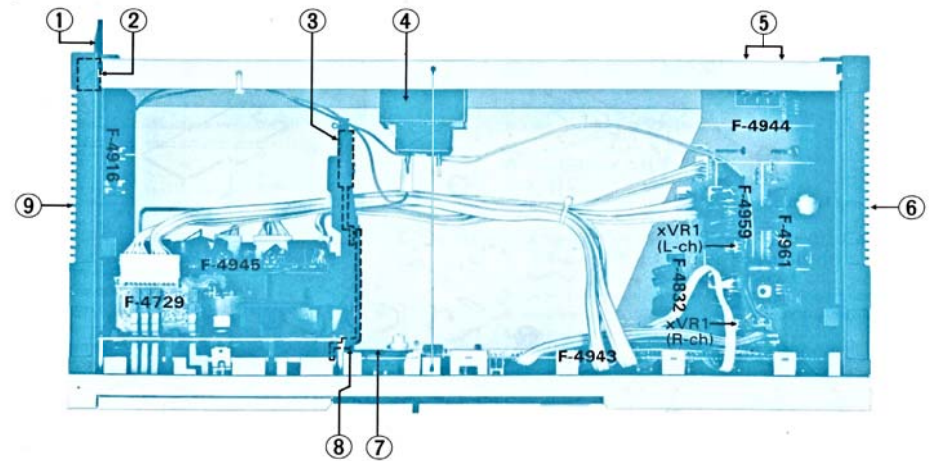

Parts List < Top View >

Parts No.	Stock No.	Description
Δ 1	38005400	Power Supply Cord (XX,XX-V,CSA)
Δ	38004700	Power Supply Cord (UL)
Δ	38004500	Power Supply Cord (EU,AS)
Δ	38004300	Power Supply Cord (BS)
2	47157300	AC Cord Cover
3	48126700	Damper Ass'y
Δ 4	15019701	Power Transformer (XX)
Δ	15019709	Power Transformer (XX-V)
Δ	15019702	Power Transformer (UL,CSA)
Δ	15019705	Power Transformer (EU,BS,AS)
5	46371500	4P Terminal, LINE OUT
6	47768700	Side Panel Ass'y (R) < Silver Model >
	47874800	Side Panel Ass'y (R) < Black Model >
7	47768200	Counter Belt
8	47628500	Damper Joint Shaft
9	47768800	Side Panel Ass'y (L) < Silver Model >
	47874900	Side Panel Ass'y (L) < Black Model >
Δ	48175200	Plug, Voltage Selector (XX-V)
Δ	07204700	Slide SW., Voltage Selector (EU,BS,AS)

10. SCHEMATIC DIAGRAM 10-1. Audio Amp. Section

• Design and specifications subject to change without notice for improvement.  
 • La présentation et les spécifications sont susceptibles d'être modifiées sans préavis par suites d'améliorations éventuelles.  
 • Änderungen, die dem technischen Fortschritt dienen, bleiben vorbehalten.

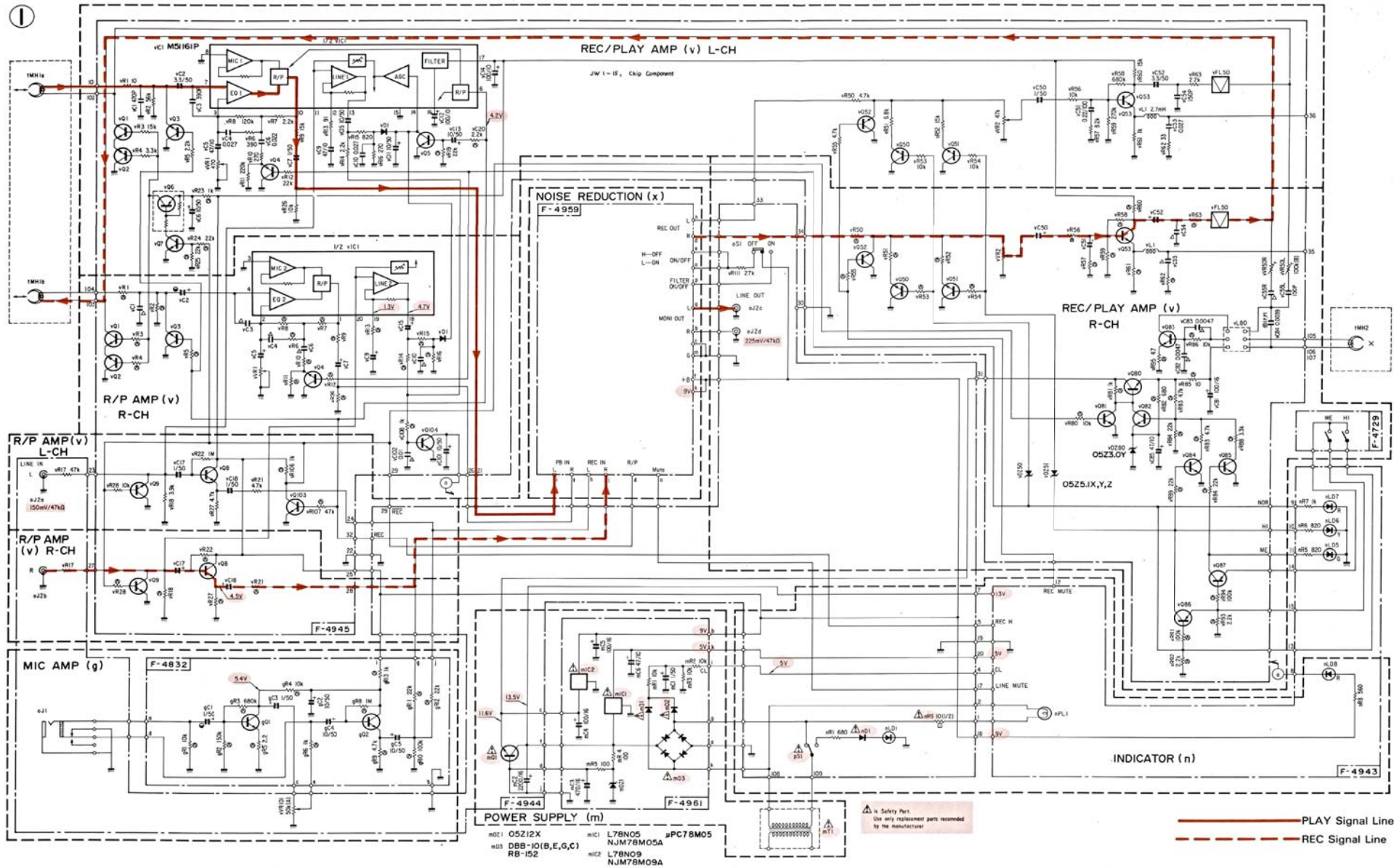

- 2SA952
- 2SA1283
- 2SC1845
- 2SC2001
- 2SC2302L
- 2SC3243
- 2SC3244
- 25D357
- 25A1175
- 25A1115
- 25C1740S
- 25C2458
- 25D1468S
- 25C2603
- DAT124ES
- L78N05
- L78N09
- BA6208
- PD4066C
- BU4066B
- MS1161P
- MSM4066BS
- TA7629P
- TC4066P
- TC8305P-014
- NJM78M05A
- NJM78M09
- DBB10-B
- 1S1588TP-3
- 1S2473T77
- 05Z3.0
- 05Z5.1
- 05Z12
- RLS-73

1  
2  
3  
4  
5



10-2. Logic Control Section

②

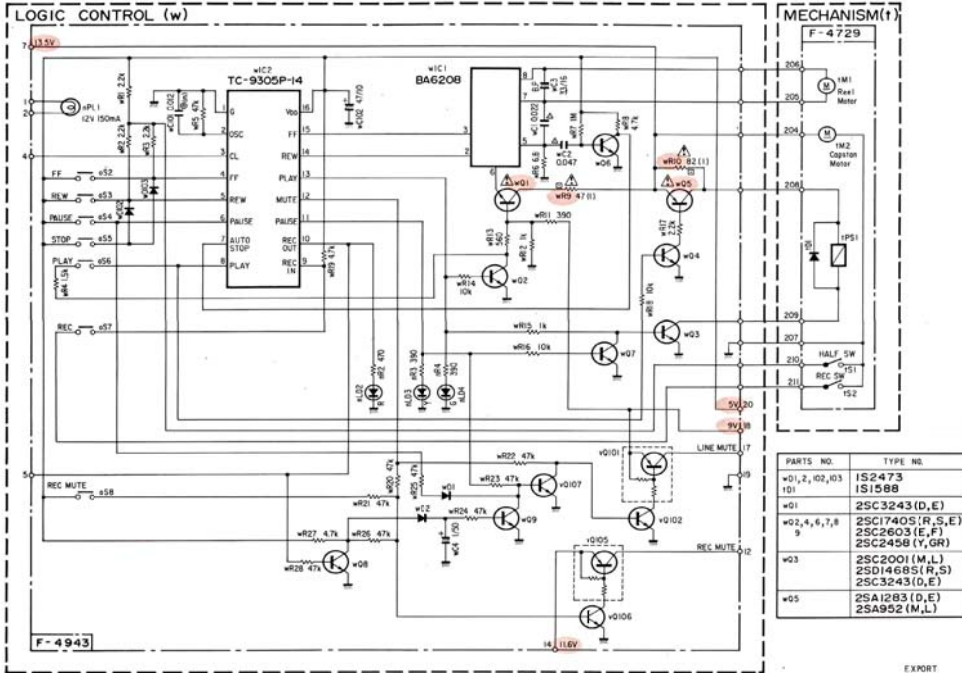

- SYMBOL OF FUNCTION**
- (g) MIC AMP
  - (m) POWER SUPPLY
  - (o) SELECTOR
  - (p) FIXED PARTS
  - (t) MECHANISM
  - (v) REC/PLAY AMP
  - (m) LOGIC CONTROL
  - (x) NOISE REDUCTION

OPTIONAL USE OF SEMICONDUCTOR

PARTS NO.	TYPE NO.
w01, 2	2SC1845 (E, F)
w03	2SC2001 (L, M)
	2SD1468S (R, S)
w04, 5, 7-9, w0-53	2SC2603 (E, F)
81, 82, 84, 85	2SC1740S (R, S, E)
102-104, 106, 107	2SC2458 (Y, GR)
102, 103, 105, 108	2SC2785 (J, H, F, E)
w06, w01, w05	DTA124
w08	2SC3243 (D, E)
w08S	2SC3244 (D, E)
	2SC1627A (O, Y)
w08S, B7	2SA1115 (E, F)
	2SA933S (R, S, E)
	2SA1175 (J, H, F, E)
g01	2SC2320 (L, E, F, G)
	2SC1845 (E, F)
w01	2SD357 (D, E)
w01, 2, w01	IS2473
w01	IS1588
h1, w1, 7, 7, 8	TLS-123
	SEL-2210S
h1, w3, 6	TLY-123
	SEL-2910A
h1, w4, 5	TLG-123A
	SEL-2410E

**SYMBOL**

- VA Ceramic Capacitor
- AB Barium Layer Capacitor
- MB Meter Capacitor
- LE Low-Leak Electrolytic
- BP Bi-Polar Electrolytic
- DI Non-Inflammable Dielectric
- CC Chip Component (Cylindrical Type)
- CC Chip Component
- FR Fusing Resistor
- MP Polypropylene Film

**RESISTORS**  
Are in ohms, 1/4 Watts, ±5% Tolerance  
Unless Otherwise Noted: 1/8W, 1/4W, 1/2W

**CHIP RESISTORS:** Are 1/8 Watts

**CAPACITORS**  
Are in µF, Unless Otherwise Noted: P3P

**Electrolytic Capacitor:**  
Capacitance (µF)/Volt (V)

Each D.C. Voltage shows the nominal value in volts during recording.

**⚠ Safety Part.**  
Use only replacement parts recommended by the manufacturer.

— PLAY Signal Line  
- - - REC Signal Line

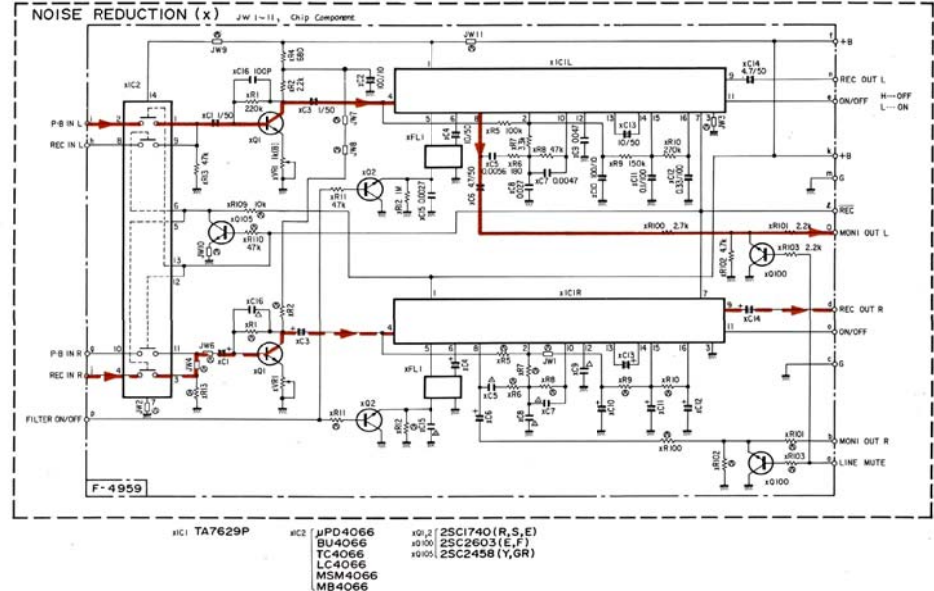



## 11. PACKING LIST

Parts No.	Stock No.	Description
1	47859900	Vinyl Cover
2	47764600	Styrofoam Packing
3	47769900	Carton Case < Silver Model > (XX,UL,CSA,EU,BS,AS)
	47770000	Carton Case < Black Model > (XX,UL,CSA,EU,BS,AS)
	47770100	Carton Case < Silver Model > (XX-V)
	47770200	Carton Case < Black Model > (XX-V)

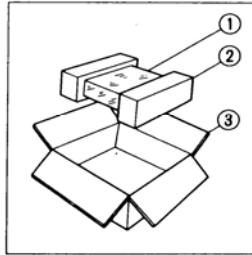

## 12. ACCESSORY LIST

Stock No.	Description
48181100	PJP Cord
94300500	Head Cleaner
46966500	Opening Instruction

•Note: XX-V<EXPORT (V)> Standard Version with Inner Voltage Selector Switch.  
("V" mark is indicated on the carton case.)

D-35BF



SANSUI ELECTRIC CO., LTD.:

SANSUI ELECTRONICS CORPORATION:

SANSUI ELECTRONICS (U.K.) LTD.:

SANSUI ELECTRONICS G.M.B.H.:

14-1, Izumi 2-chome, Suginami-ku, Tokyo 168 Japan  
PHONE: (03) 324-8891/TELEX: 232-2076 (International Division)

1250 Valley Brook Ave. Lyndhurst, N.J. 07071 U.S.A.  
17150 South Margay Ave. Carson, California 90746 U.S.A.

3036 Koapaka Street. Honolulu, Hawaii 96819 U.S.A.

Unit 10A, Lyon Industrial Estate, Rockware Avenue, Geenford, Middx UB6, OAA, England  
Pau Ehrich Strasse 8, 6074 Rödermark 2, West Germany

(SM1-218)

Printed in Japan (D45220M) <Stock No. 36514400>

10. SCHEMATIC DIAGRAM 10-1. Audio Amp. Section

\* Design and specifications subject to change without notice for improvement.  
 \* La présentation et les spécifications sont susceptibles d'être modifiées sans préavis par suites d'améliorations éventuelles.  
 \* Änderungen, die dem technischen Fortschritt dienen, bleiben vorbehalten.

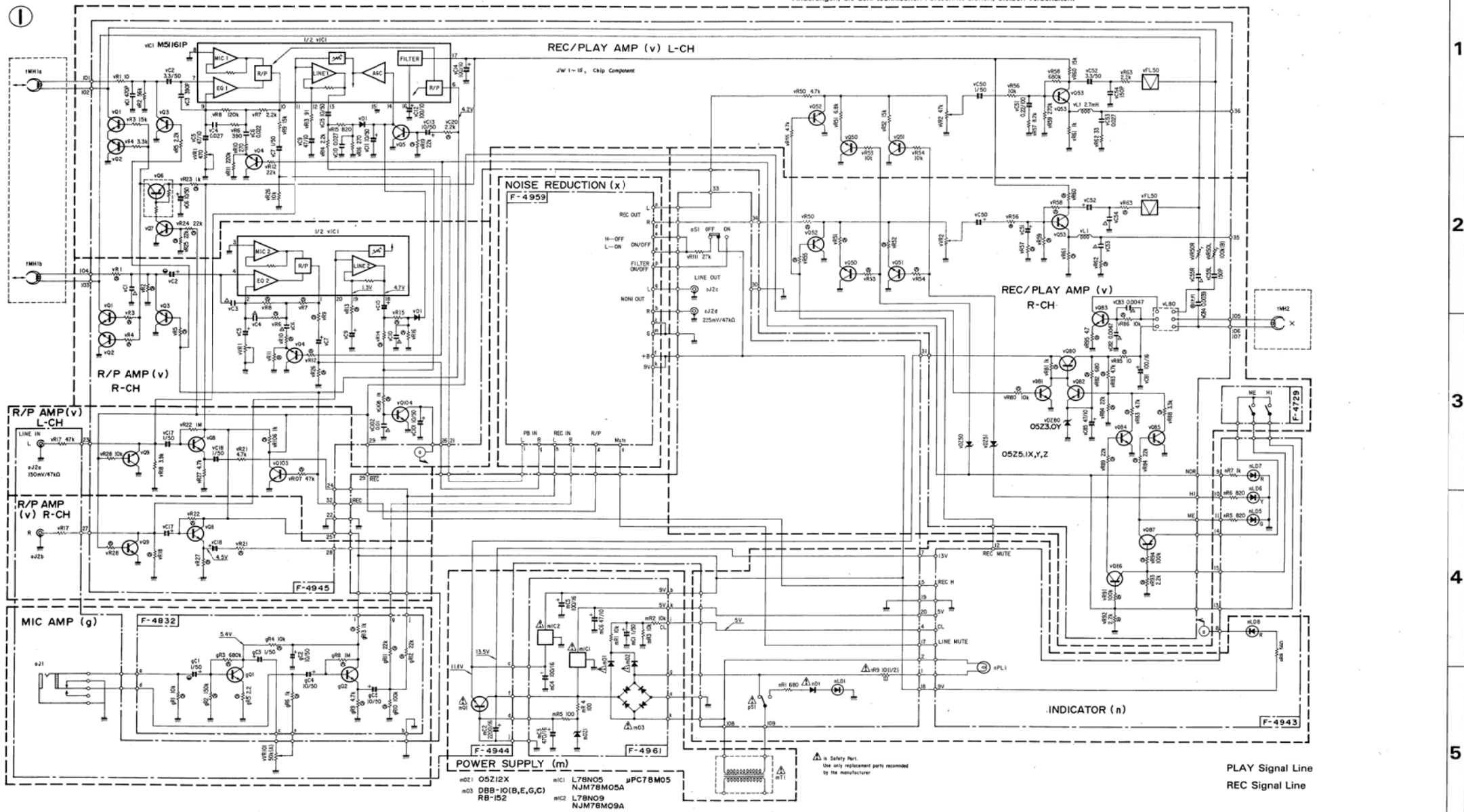

PLAY Signal Line  
REC Signal Line

1  
2  
3  
4  
5

10-2. Logic Control Section

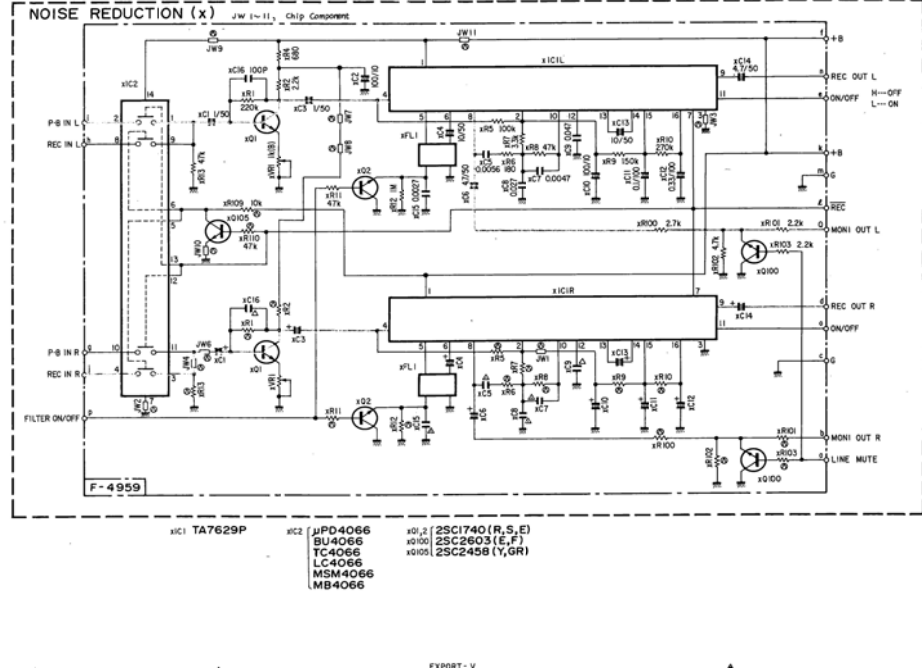
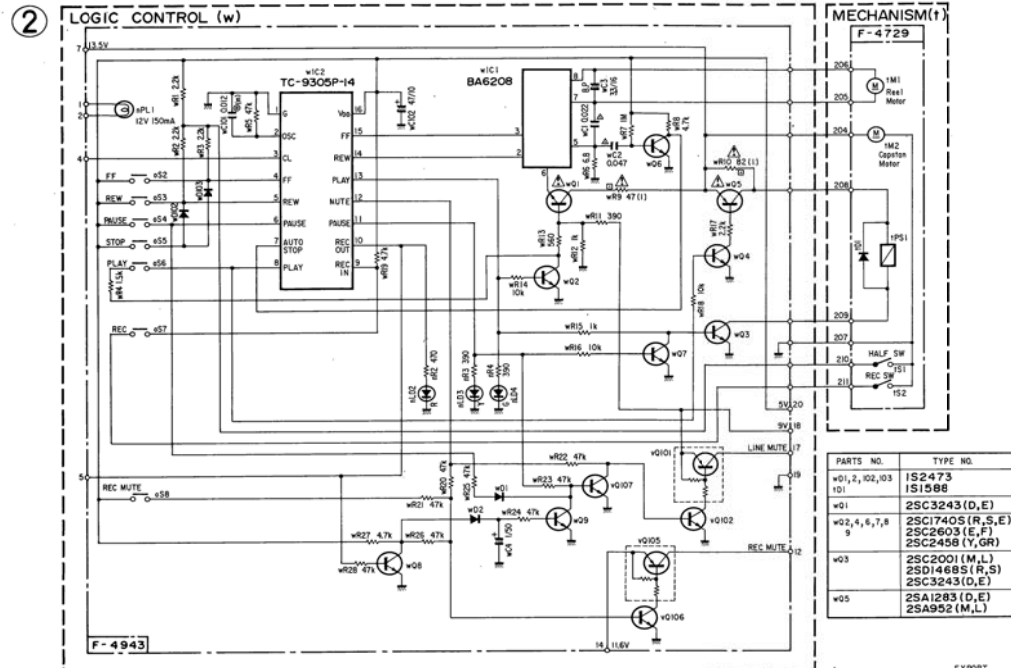

- SYMBOL OF FUNCTION**
- (g) MIC AMP
  - (m) POWER SUPPLY
  - (o) SELECTOR
  - (v) FIXED PARTS
  - (†) MECHANISM
  - (r) REC/PLAY AMP
  - (m) LOGIC CONTROL
  - (x) NOISE REDUCTION

**OPTIONAL USE OF SEMICONDUCTOR**

PARTS NO.	TYPE NO.
v01,2	2SC1845 (E,F)
v03	2SC2001 (L,M)
	2SD1468S (R,S)
v04,5,7-9,50-53	2SC2603 (E,F)
81,82,84,85	2SC1740S (R,S,E)
102-104,106,107	2SC2458 (Y,GR)
g02,101,2,100,105	2SC2785 (J,H,F,E)
v06,101,105	DTA124
v080	2SC3243 (D,E)
v083	2SC3244 (D,E)
	2SC1627A (Q,Y)
v086,87	2SA1115 (E,F)
	2SA933S (R,S,E)
	2SA1175 (J,H,F,E)
q01	2SC2320 (L,E,F,G)
	2SC1845 (E,F)
m01	2SD357 (D,E)
m01,2,101	1S2473
v01	1S1588
nL01,2,7,8	TL5-123
	SEL-2210S
nL03,6	TL5-123
	SEL-2910A
nL04,5	TLG-123A
	SEL-2410E

**SYMBOL**

- △ Ceramic Capacitor
- ▲ Barrier Layer Capacitor
- ⊖ Mylar Capacitor
- ⊖ Low-Leak Electrolytic
- ⊖ P-P Bipolar Electrolytic
- ⊖ Non-Inflammable Resistor
- ⊖ Chip Component (Cylindrical Type)
- ⊖ Chip Component
- ⊖ Fusing Resistor
- ⊖ Polypropylene Film

**RESISTORS**  
Are in ohms, 1/4 Watts, ±5% Tolerance  
Unless Otherwise Noted. k: 1k, M: 1M

**CHIP RESISTORS:** Are 1/8 Watts

**CAPACITORS**  
Are in pF, Unless Otherwise Noted. P: pF

**Electrolytic Capacitor:**  
Capacitance (pF)/Volt (V)

Each D.C. Voltage shows the nominal value in volts during recording.

† is Safety Part.  
Use only replacement parts recommended by the manufacturer.

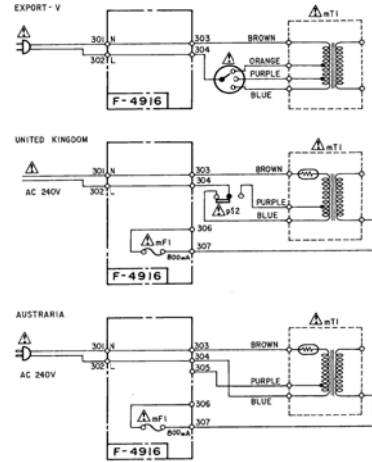
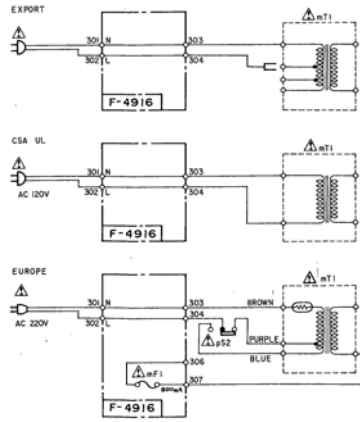

PLAY Signal Line  
REC Signal Line

\* Design and specifications subject to change without notice for improvement.  
\* La présentation et les spécifications sont susceptibles d'être modifiées sans préavis par suites d'améliorations éventuelles.  
\* Änderungen, die dem technischen Fortschritt dienen, bleiben vorbehalten.